



US 20160336803A1

(19) **United States**

(12) **Patent Application Publication**
Kurs et al.

(10) **Pub. No.: US 2016/0336803 A1**

(43) **Pub. Date: Nov. 17, 2016**

(54) **WIRELESS ENERGY TRANSFER WITH REDUCED FIELDS**

(60) Provisional application No. 61/590,856, filed on Jan. 26, 2012.

(71) Applicant: **WiTricity Corporation**, Watertown, MA (US)

Publication Classification

(72) Inventors: **Andre B. Kurs**, Chestnut Hill, MA (US); **Morris P. Kesler**, Bedford, MA (US); **Katherine L. Hall**, Arlington, MA (US); **Aristeidis Karalis**, Boston, MA (US); **Simon Verghese**, Arlington, MA (US); **Volkan Efe**, Watertown, MA (US); **Marin Soljacic**, Belmont, MA (US); **Alexander P. McCauley**, Sunnyvale, CA (US); **Maria Empar Rollano Hijarrubia**, Cambridge, MA (US)

(51) **Int. Cl.**
H02J 50/12 (2006.01)
B60L 11/18 (2006.01)
H02J 7/02 (2006.01)
H04B 5/00 (2006.01)
(52) **U.S. Cl.**
CPC **H02J 50/12** (2016.02); **H04B 5/0037** (2013.01); **H04B 5/0075** (2013.01); **B60L 11/182** (2013.01); **H02J 7/025** (2013.01)

(21) Appl. No.: **15/087,101**

(57) **ABSTRACT**

(22) Filed: **Mar. 31, 2016**

A magnetic resonator includes an inductor comprising a conductive first loop having a first dipole moment and a conductive second loop having a second dipole moment wherein a direction of the first dipole moment is substantially opposite to a direction of the second dipole moment and at least one capacitor in series with at least one of the first loop and the second loop.

Related U.S. Application Data

(63) Continuation of application No. 13/752,169, filed on Jan. 28, 2013, now Pat. No. 9,306,635.

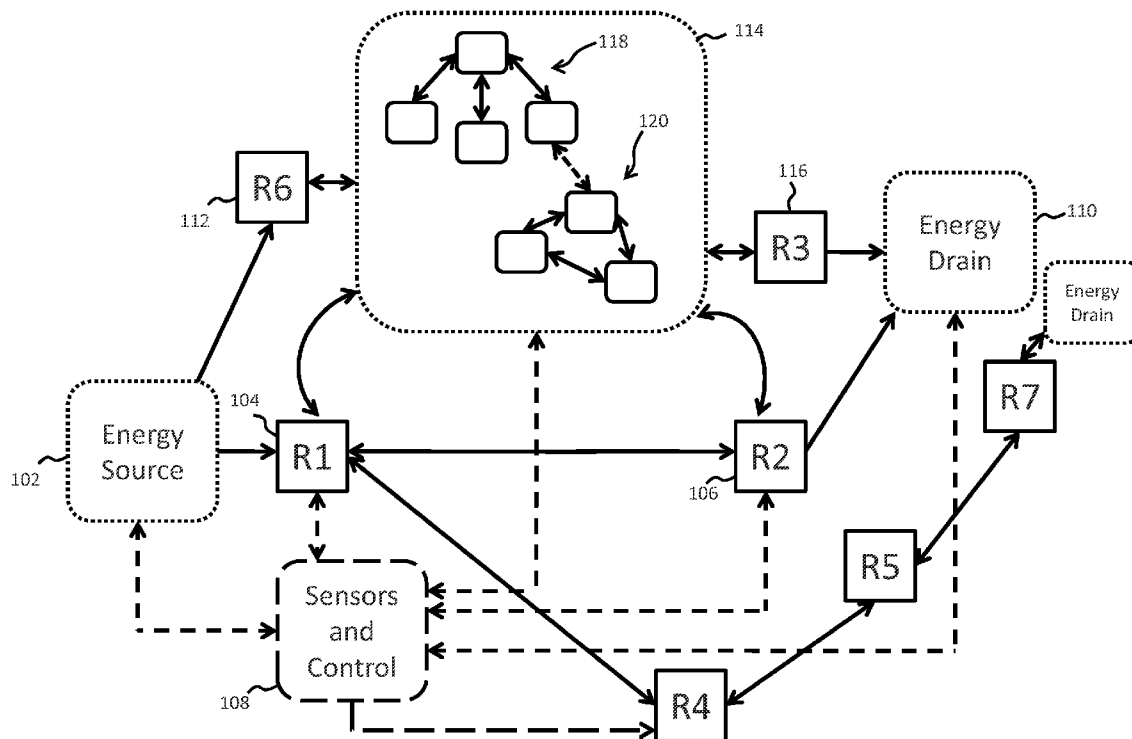

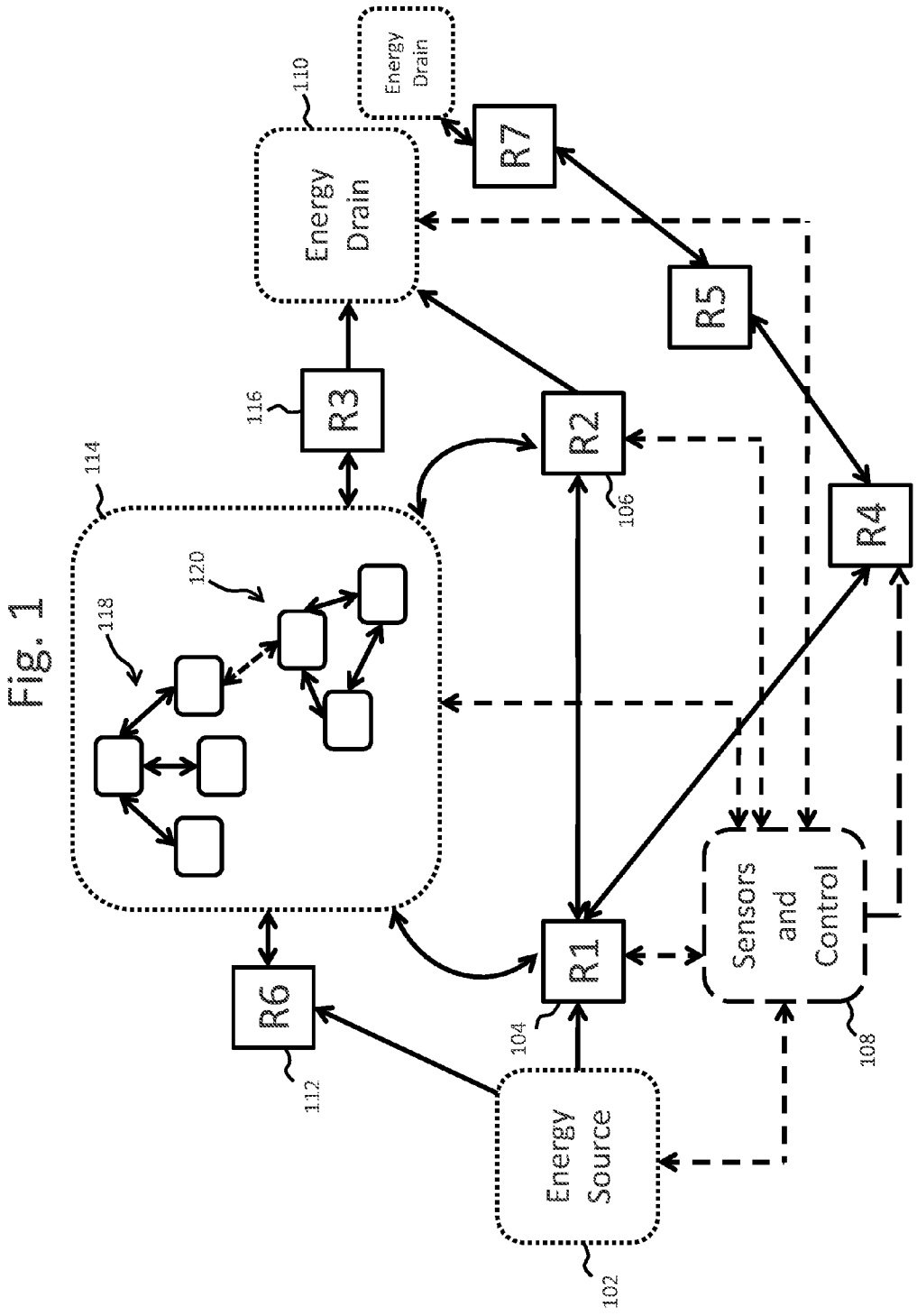

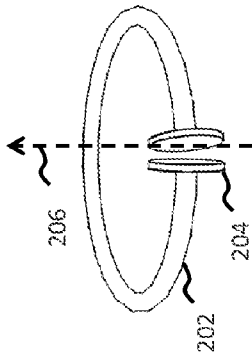

Fig. 2A

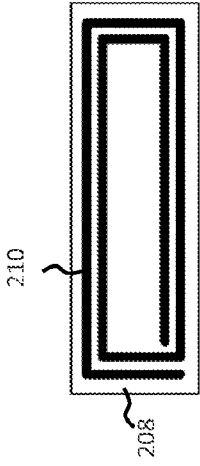

Fig. 2B

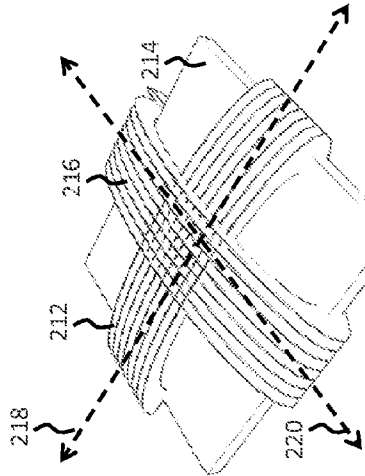

Fig. 2C

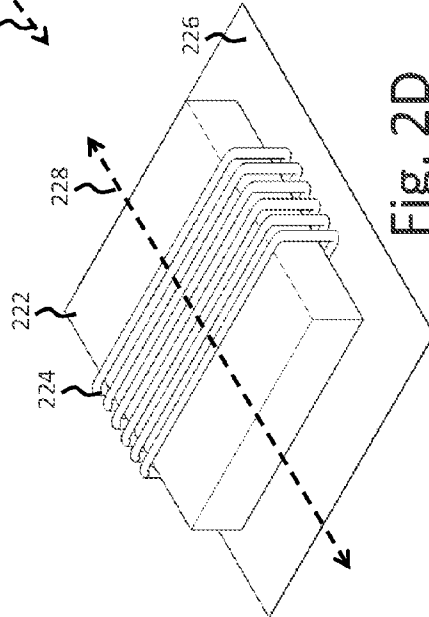

Fig. 2D

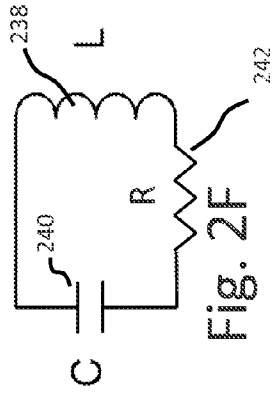

Fig. 2F

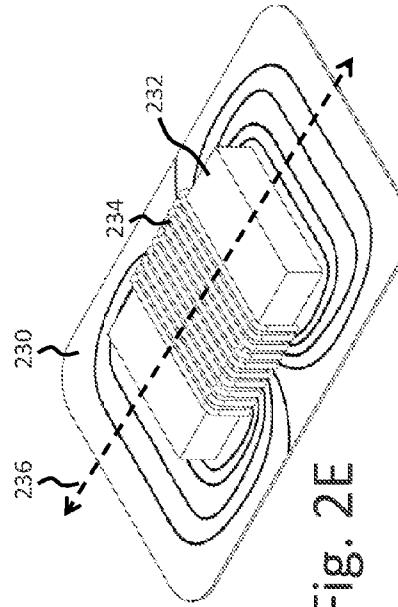
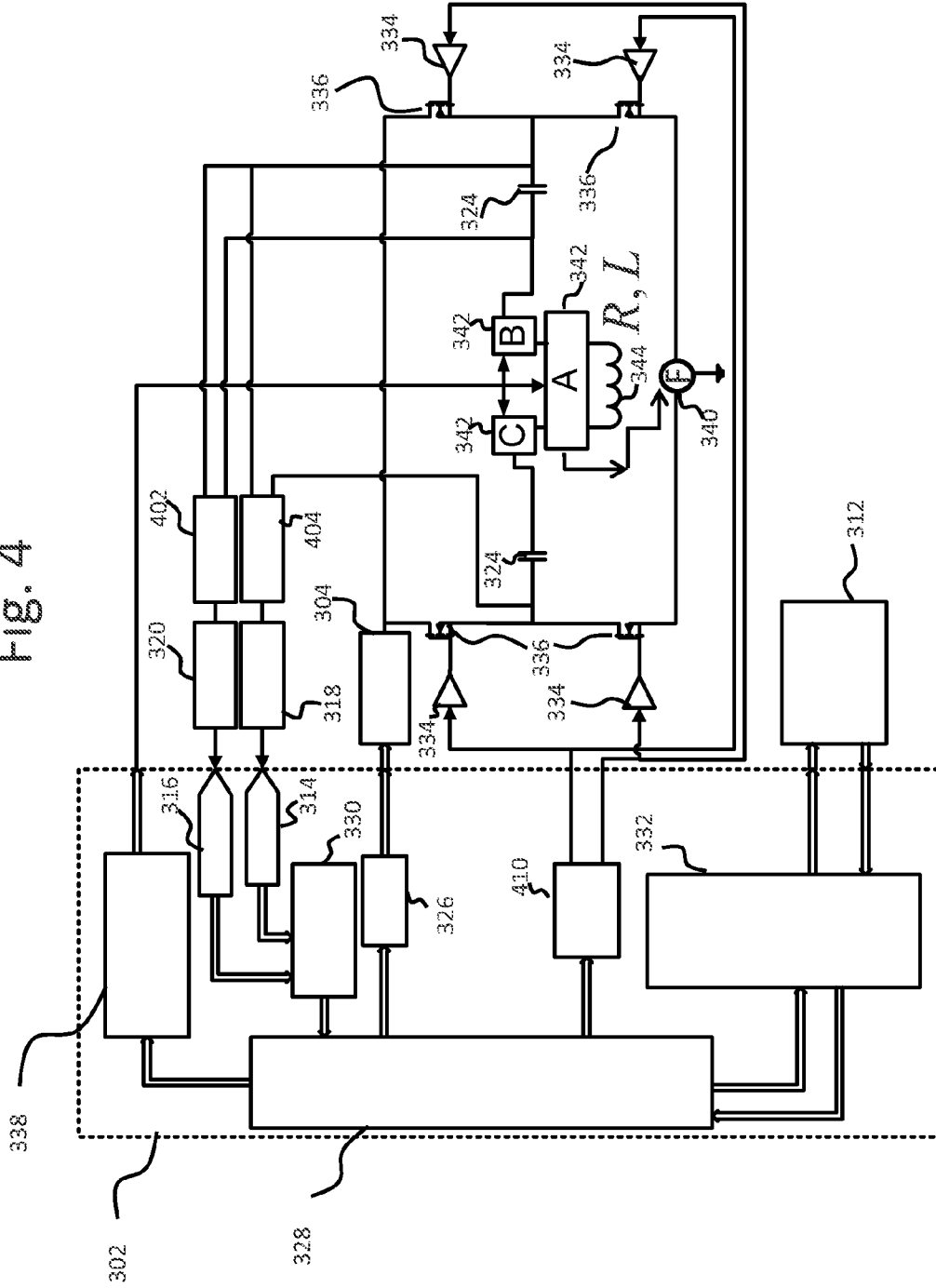

Fig. 2E

Fig. 4



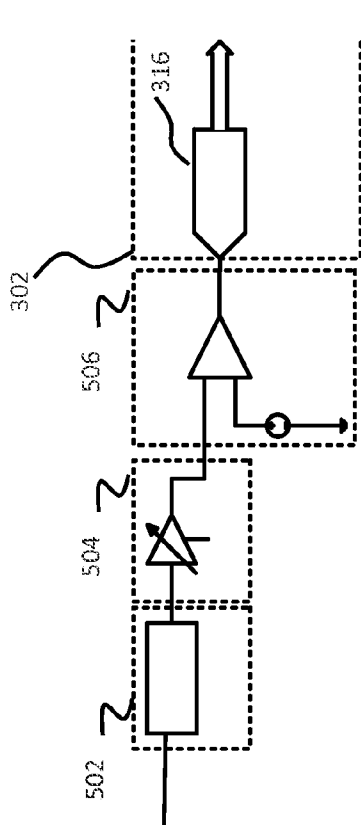

Fig. 5A

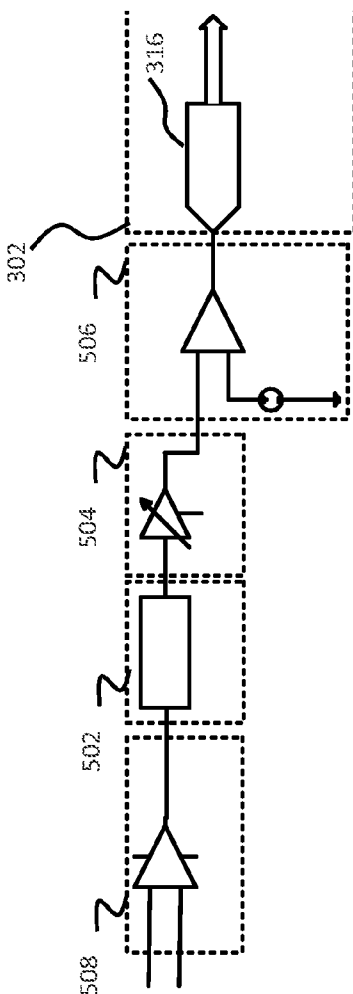

Fig. 5B

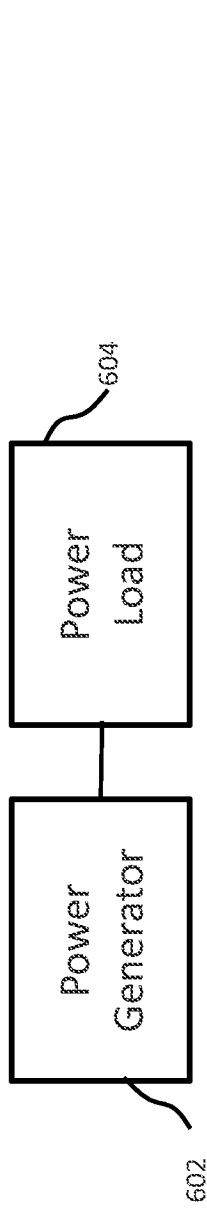

Fig. 6A

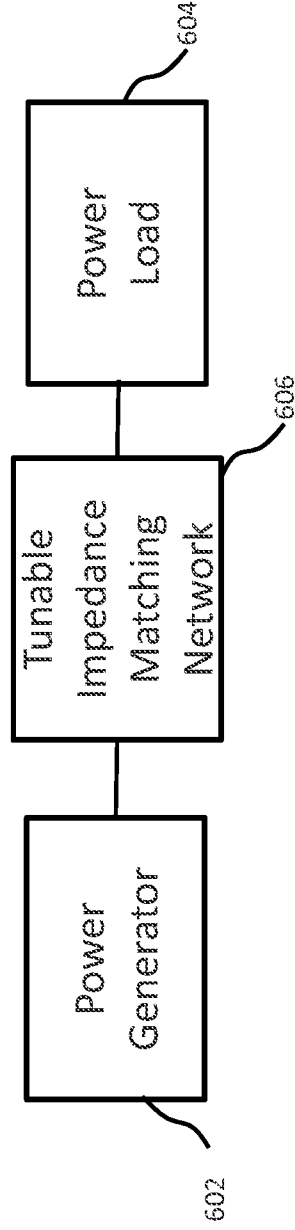

Fig. 6B

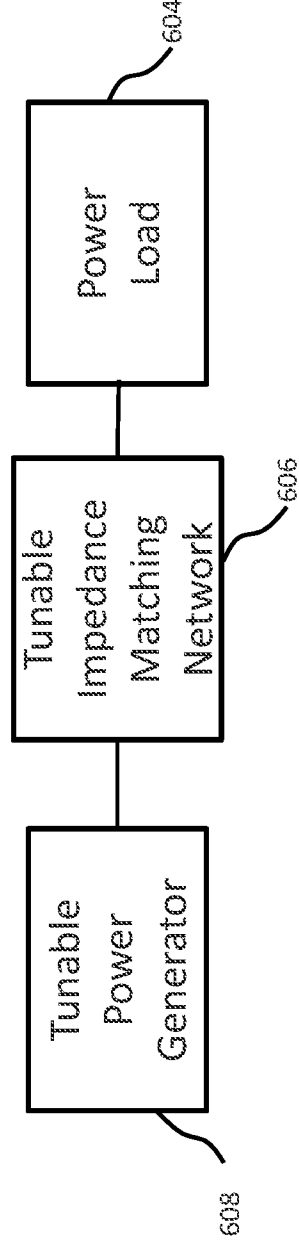

Fig. 6C

Fig. 7

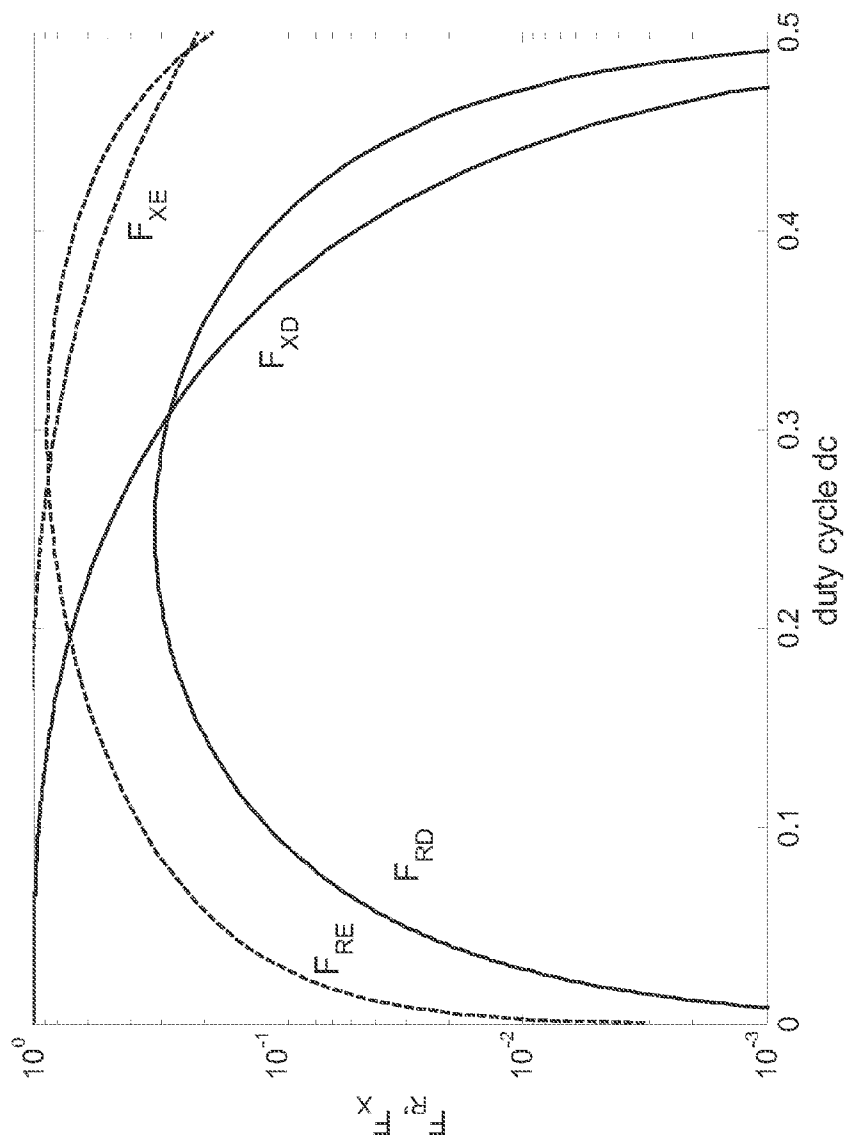

Fig. 8

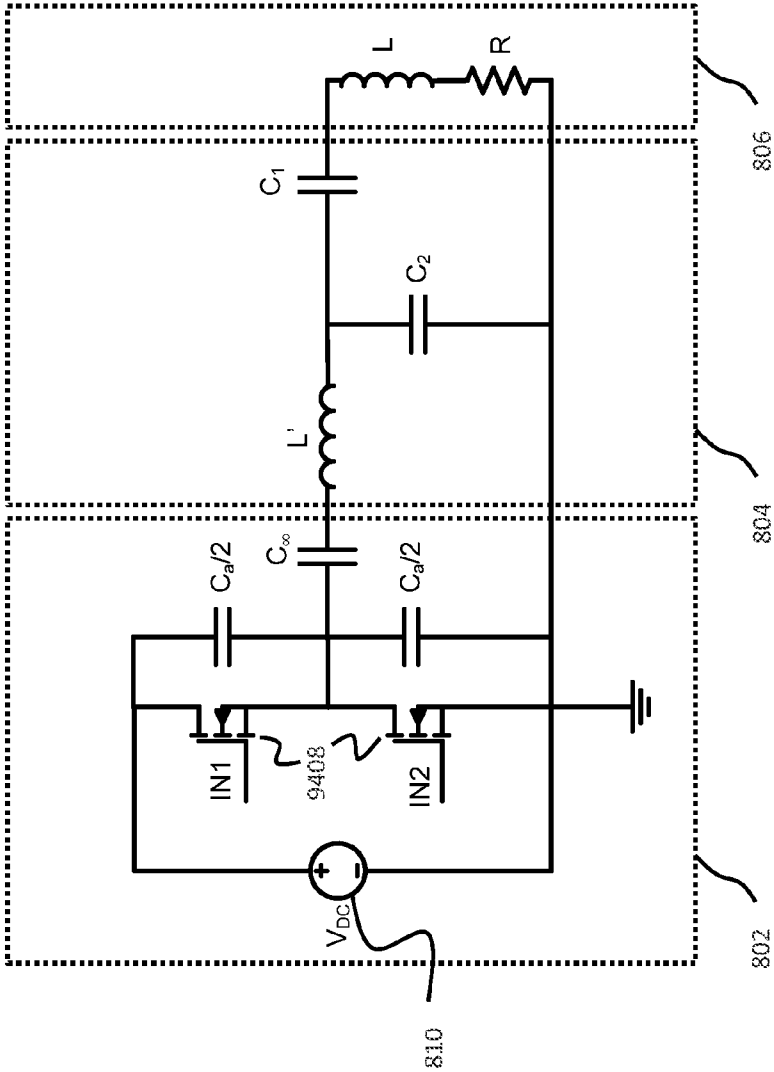

Fig. 9

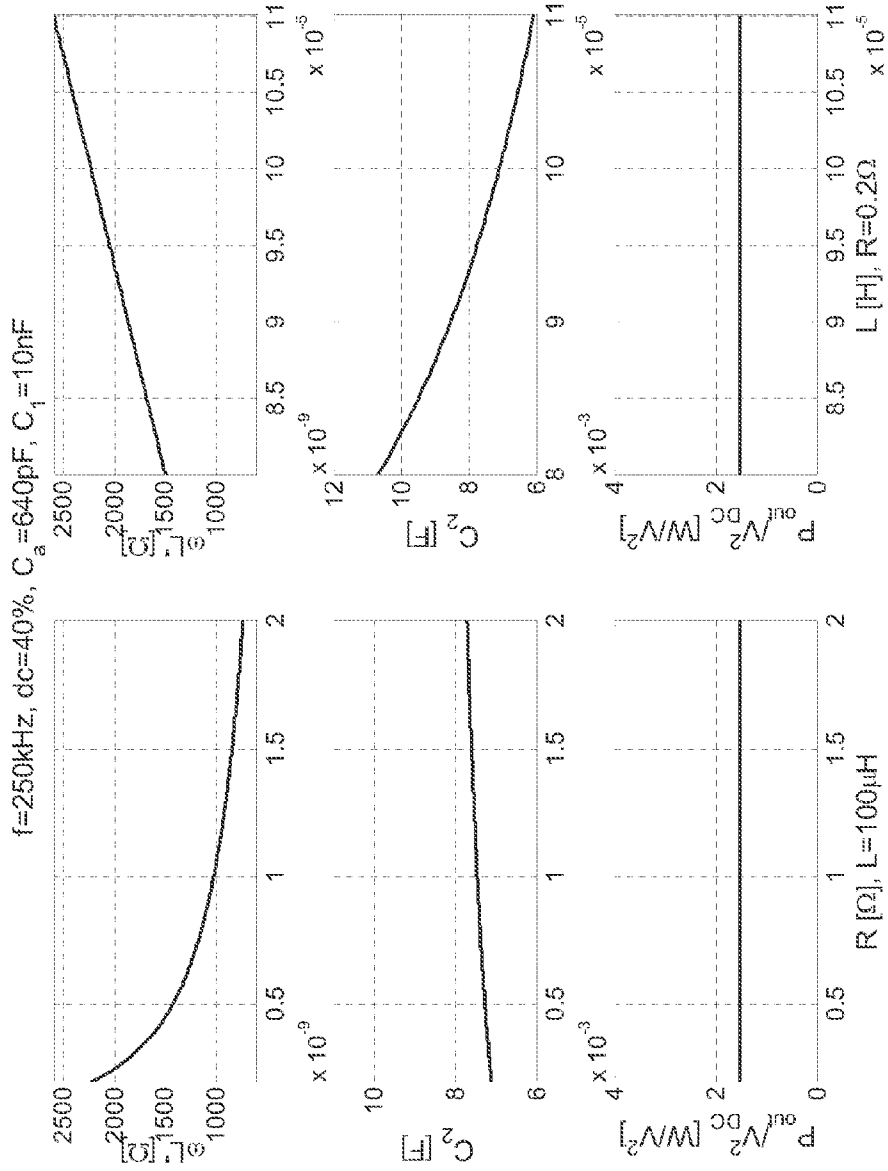

Fig. 10

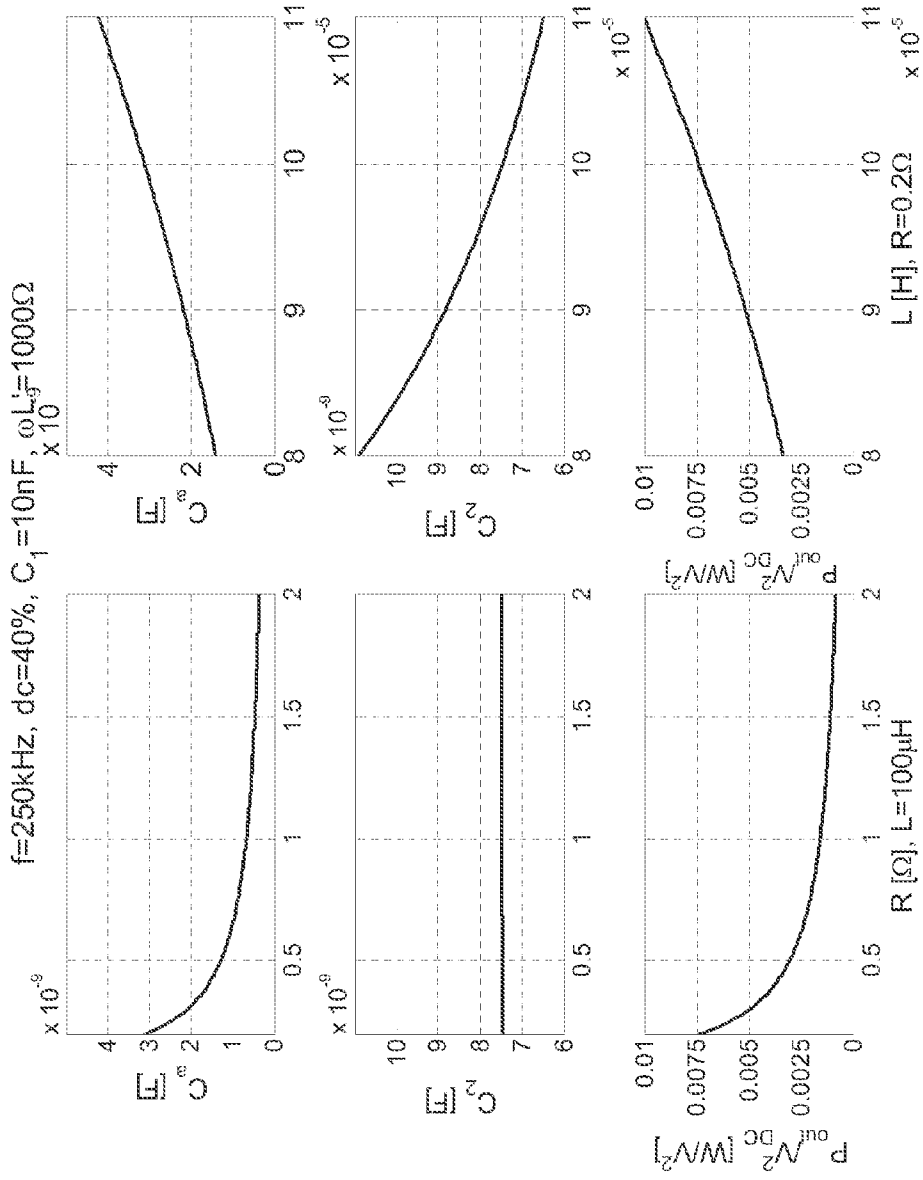

Fig. 11A

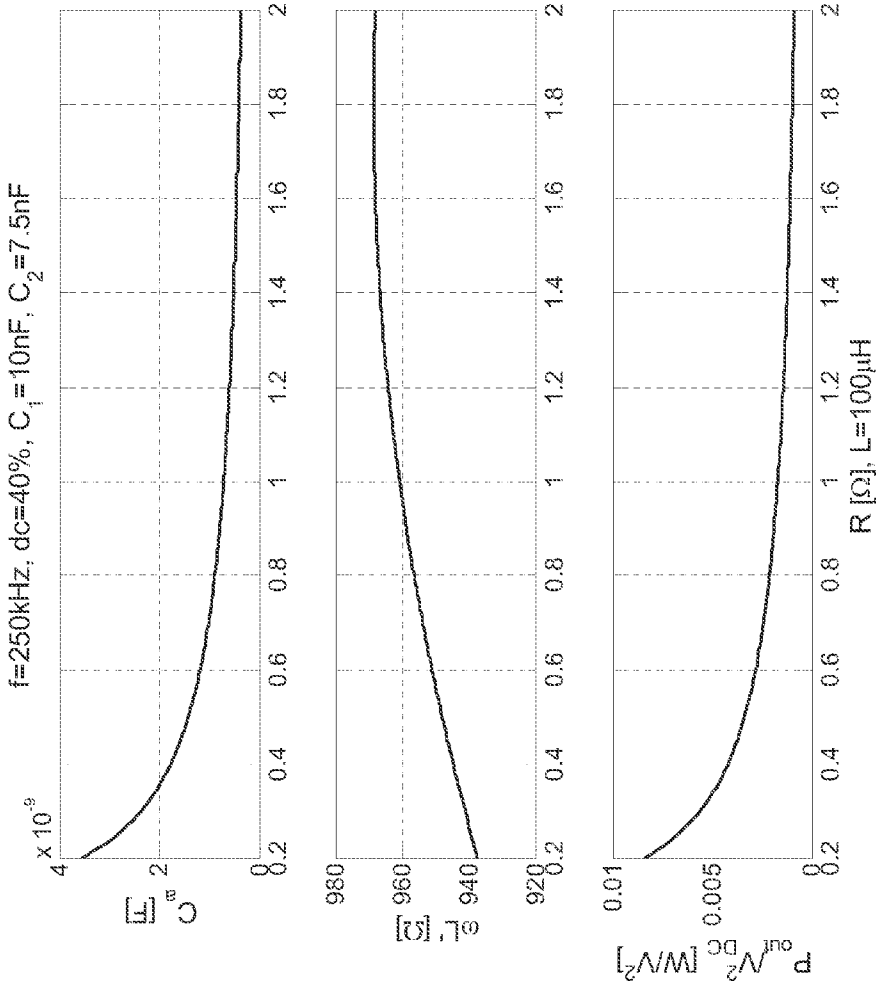

Fig. 11B

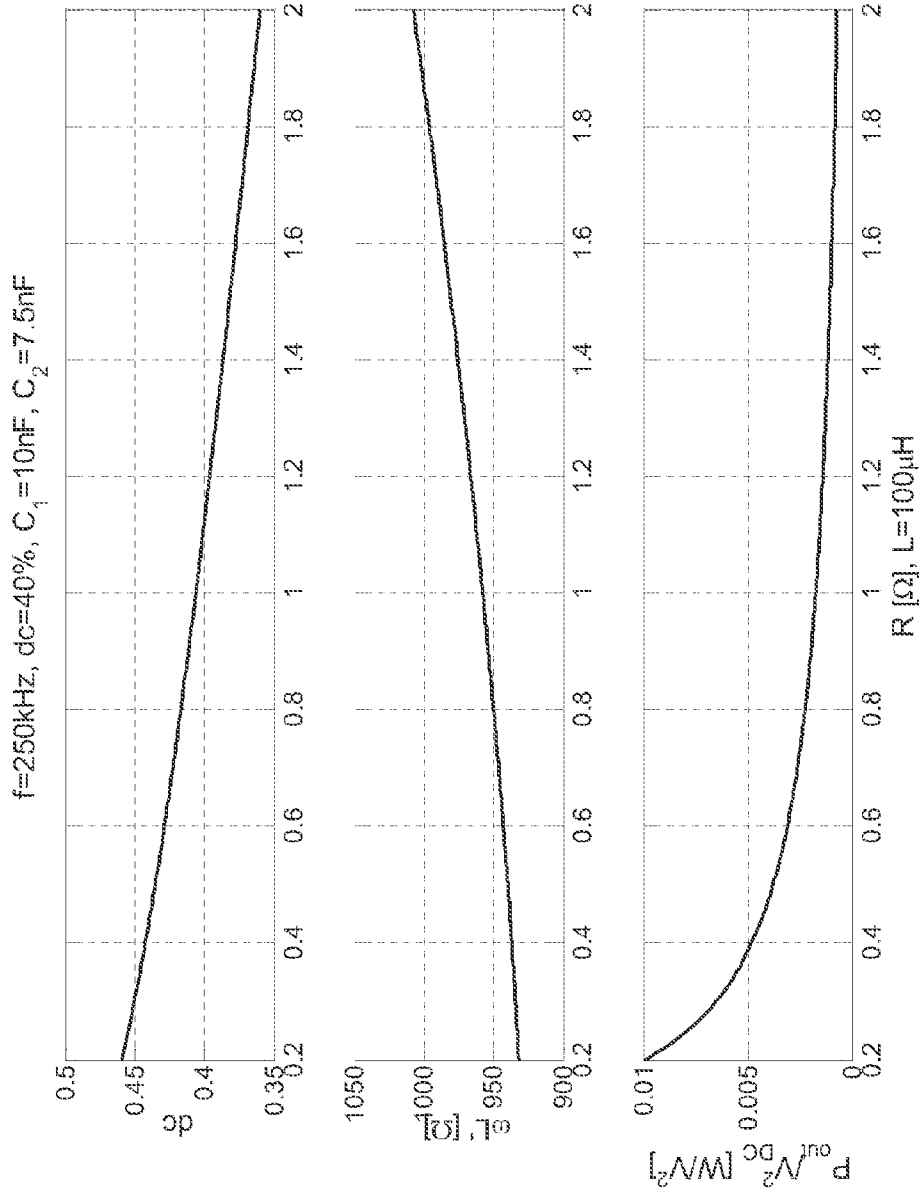

Fig. 11C

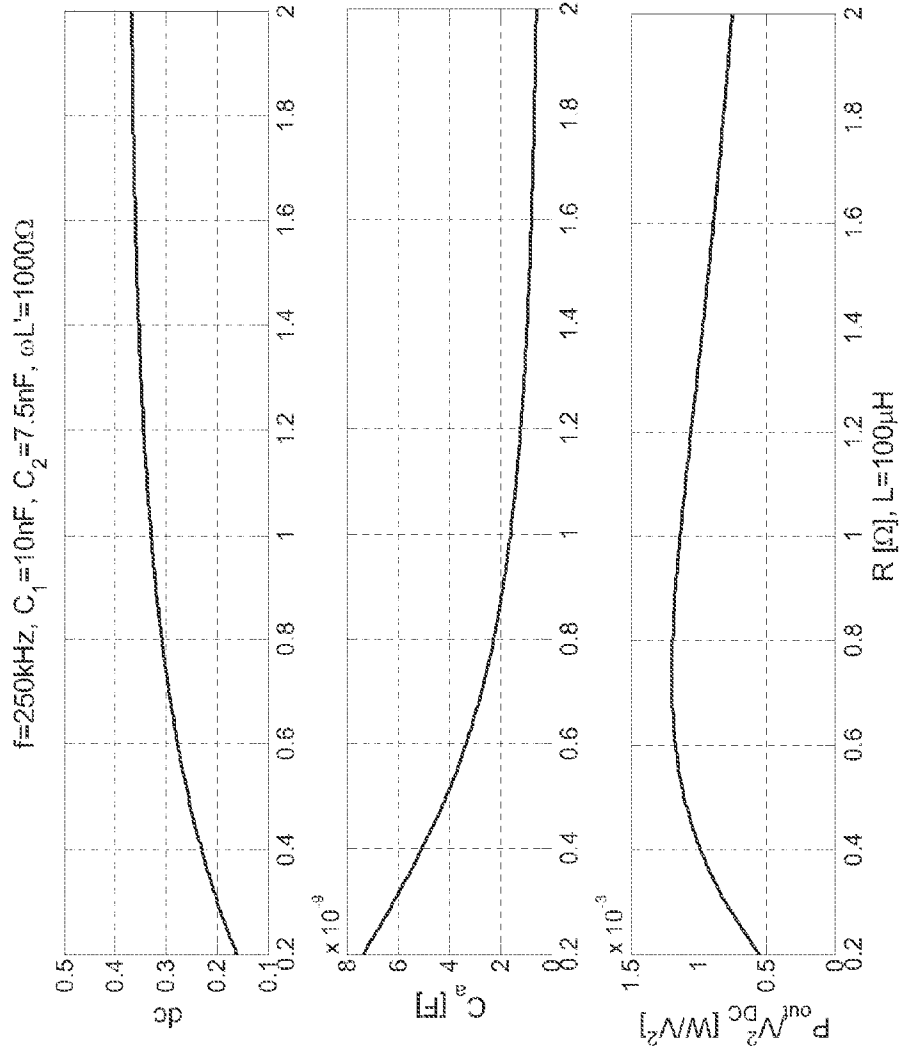

Fig. 12

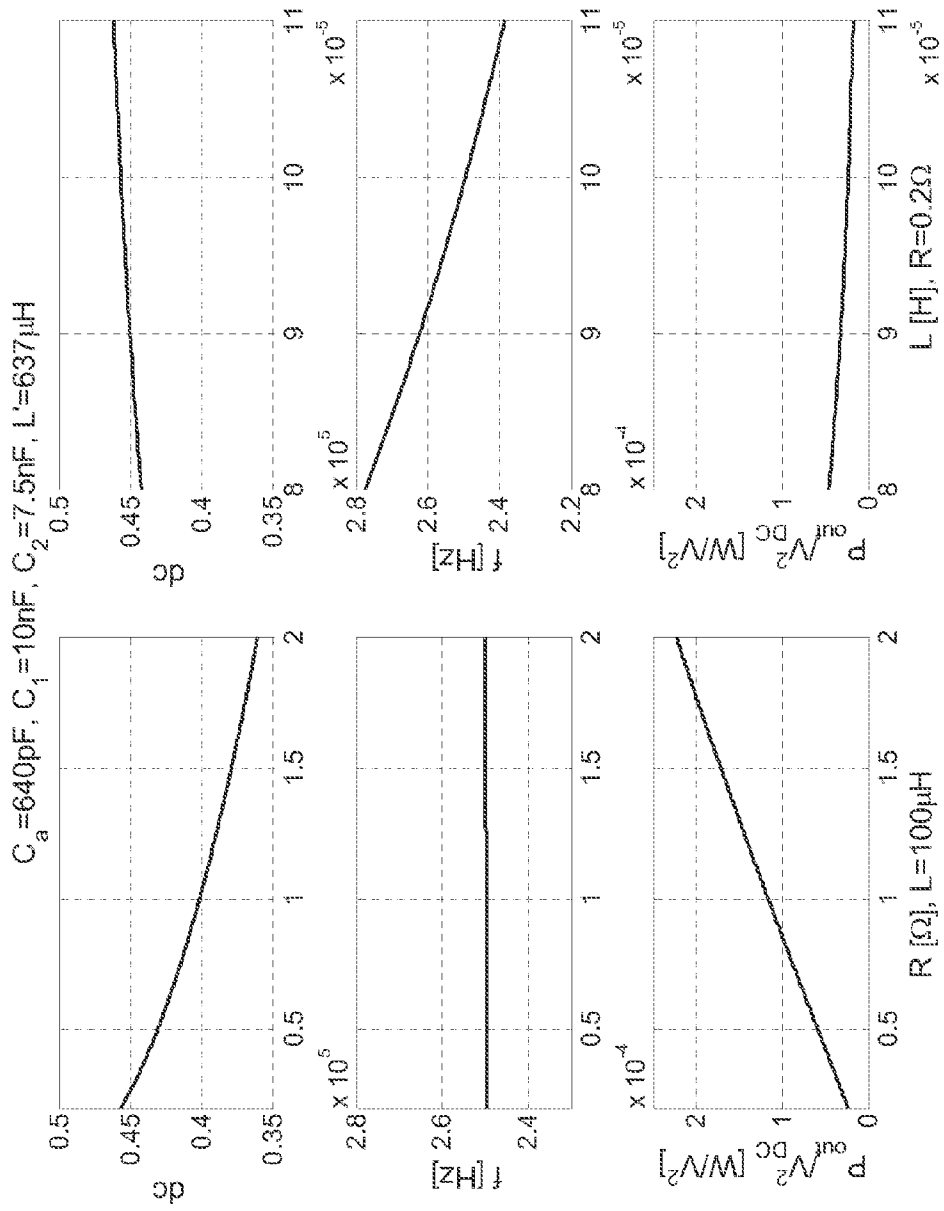

Fig. 13

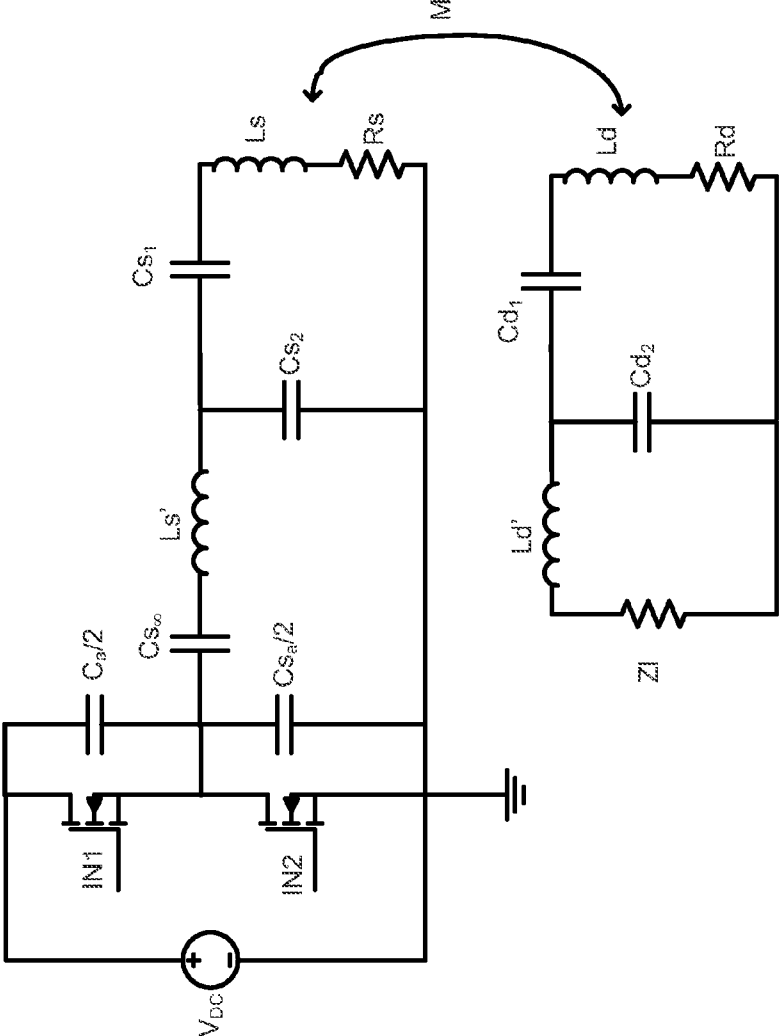
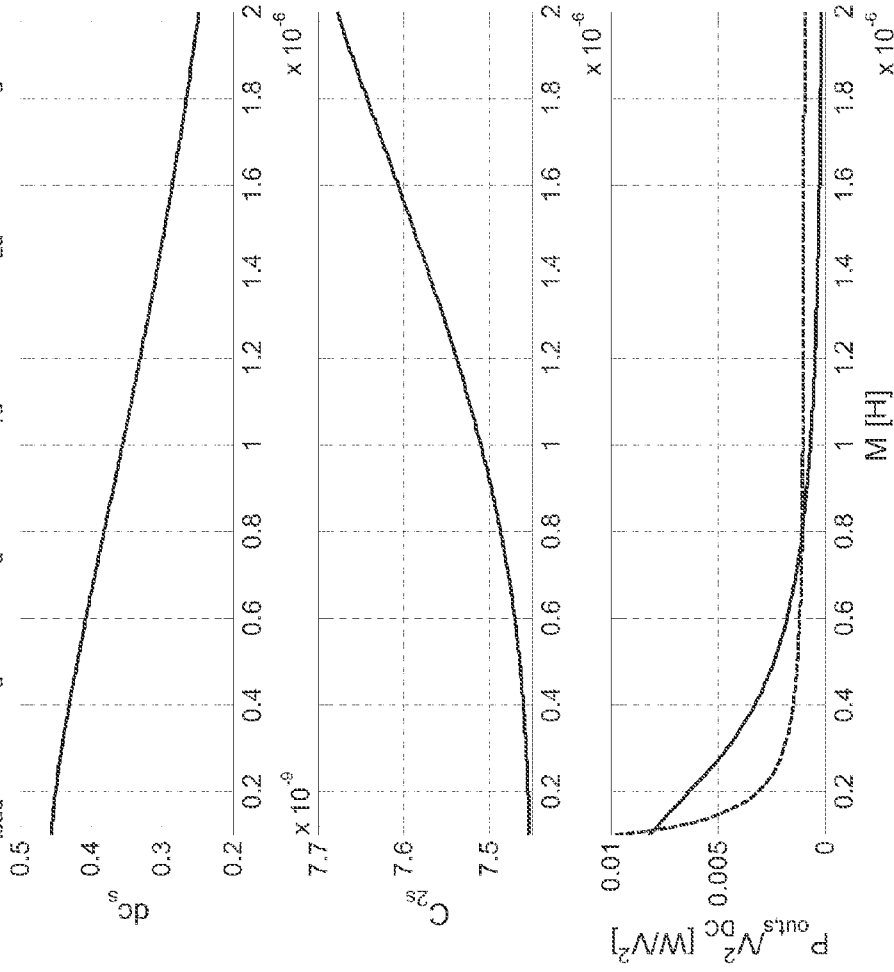

Fig. 14

$f=250\text{kHz}$, $C_{as}=640\text{pF}$, $R_s=0.19\Omega$, $L_s=100\mu\text{H}$, $C_{1s}=10\text{nF}$, $\omega L'_s=1000\Omega$
 $Z_{load}=50\Omega$, $R_d=0.3\Omega$, $L_d=40\mu\text{H}$, $C_{1d}=87.5\text{nF}$, $C_{2d}=13\text{nF}$, $\omega L'_d=400\Omega$



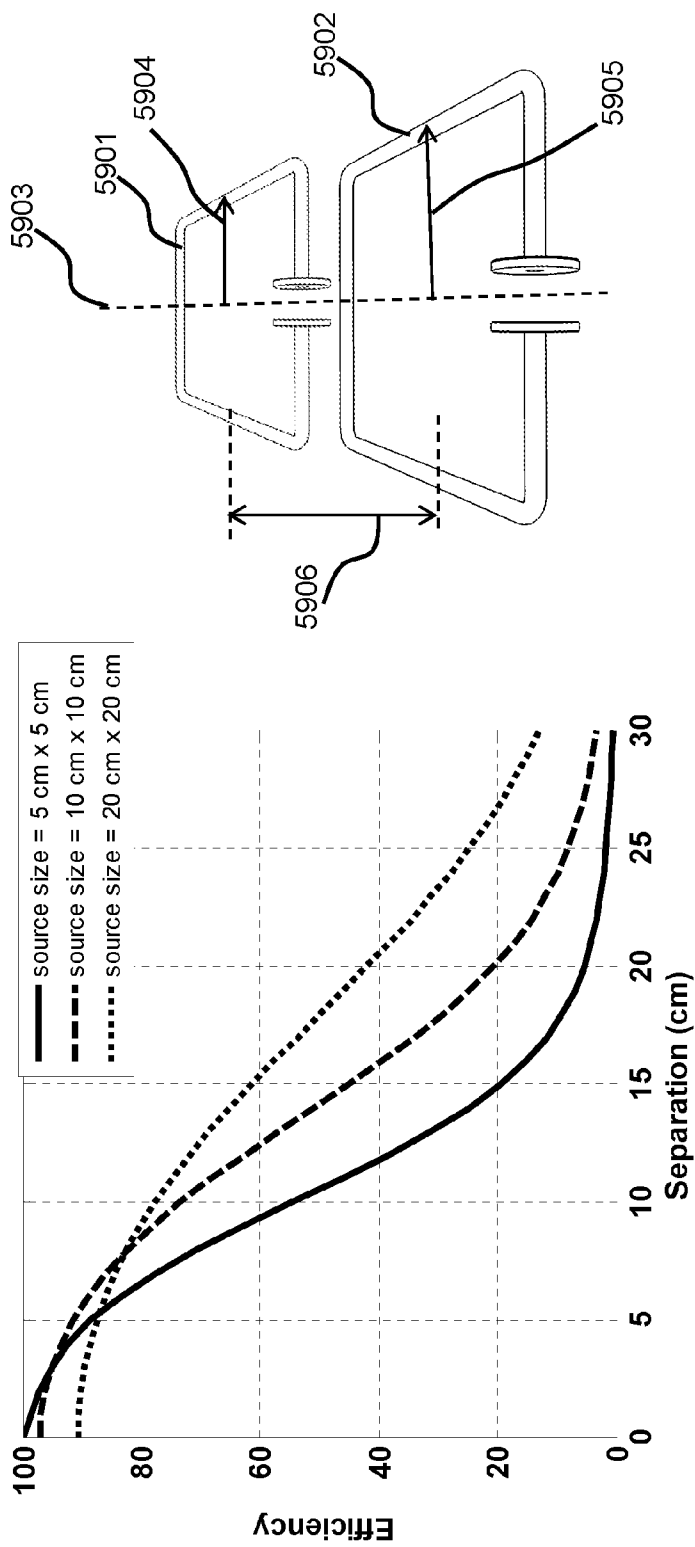

Fig. 15A

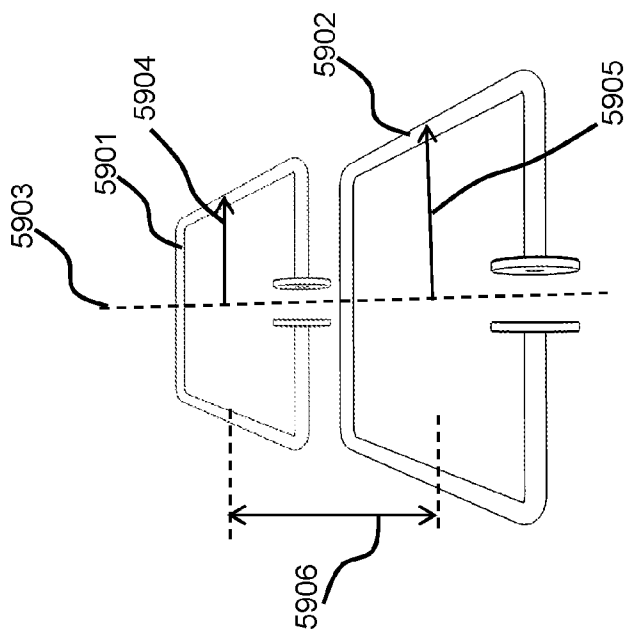

Fig. 15B

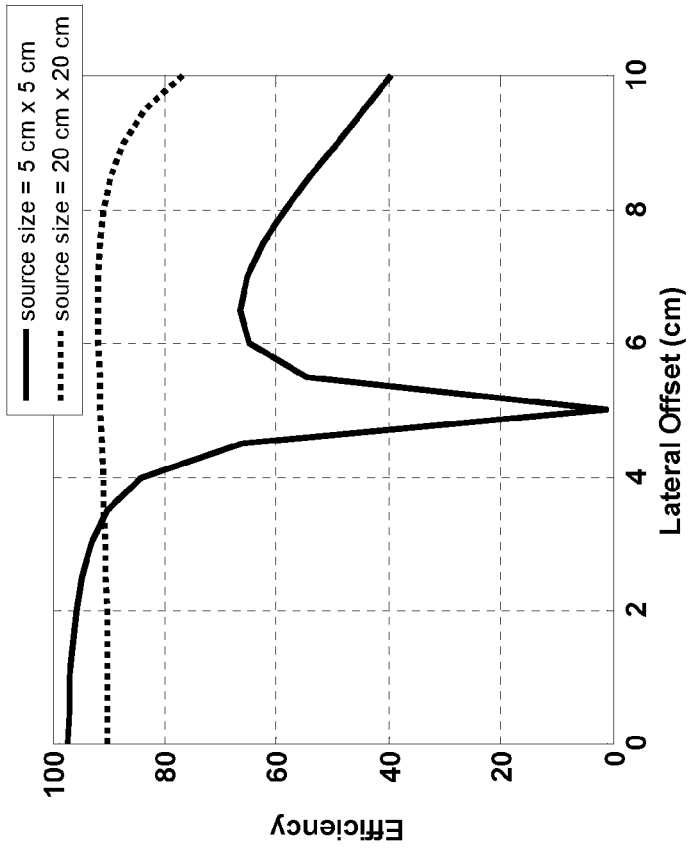
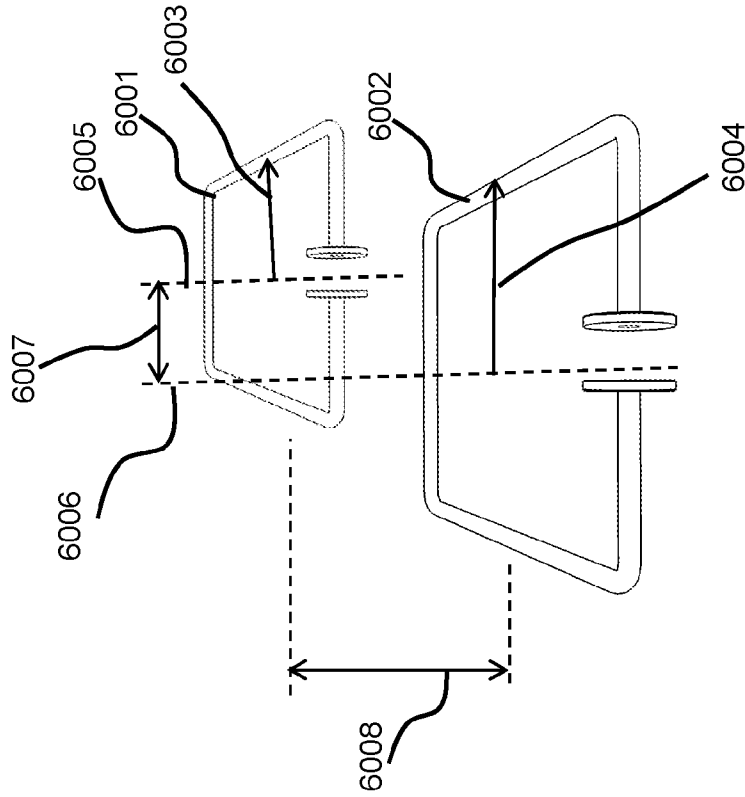

Fig. 16B

Fig. 16A

Fig. 17

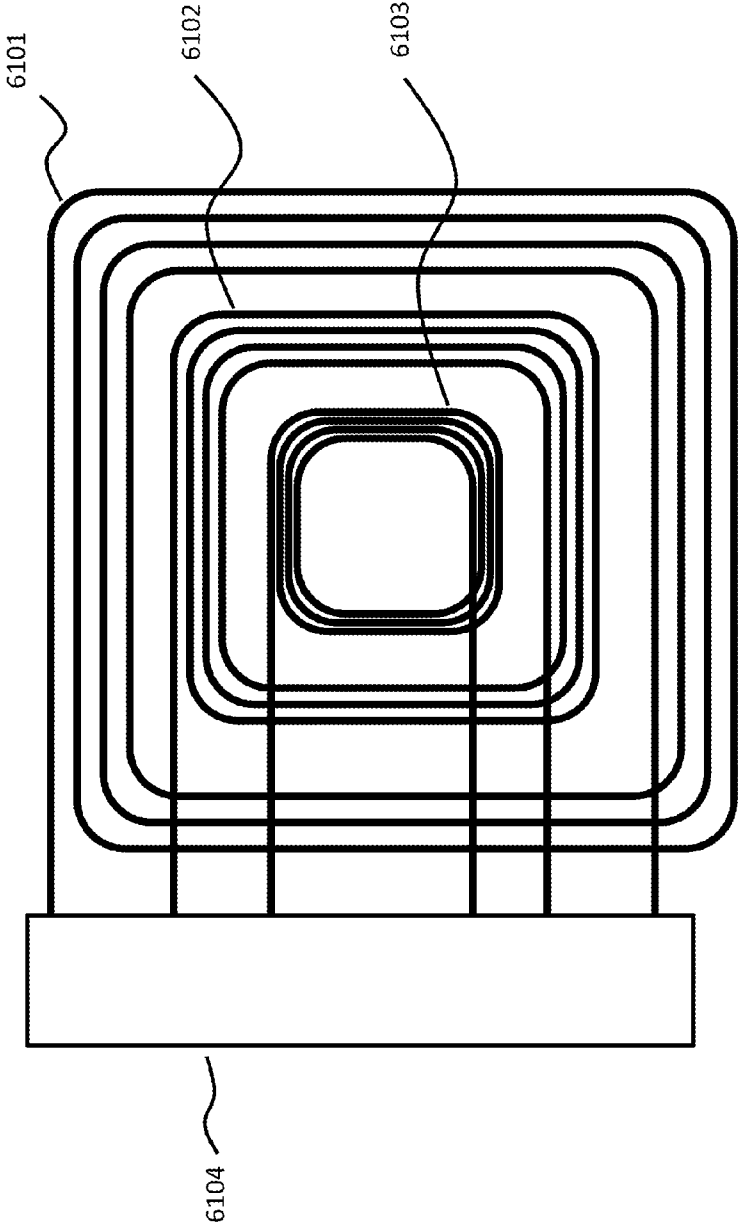

Fig. 18

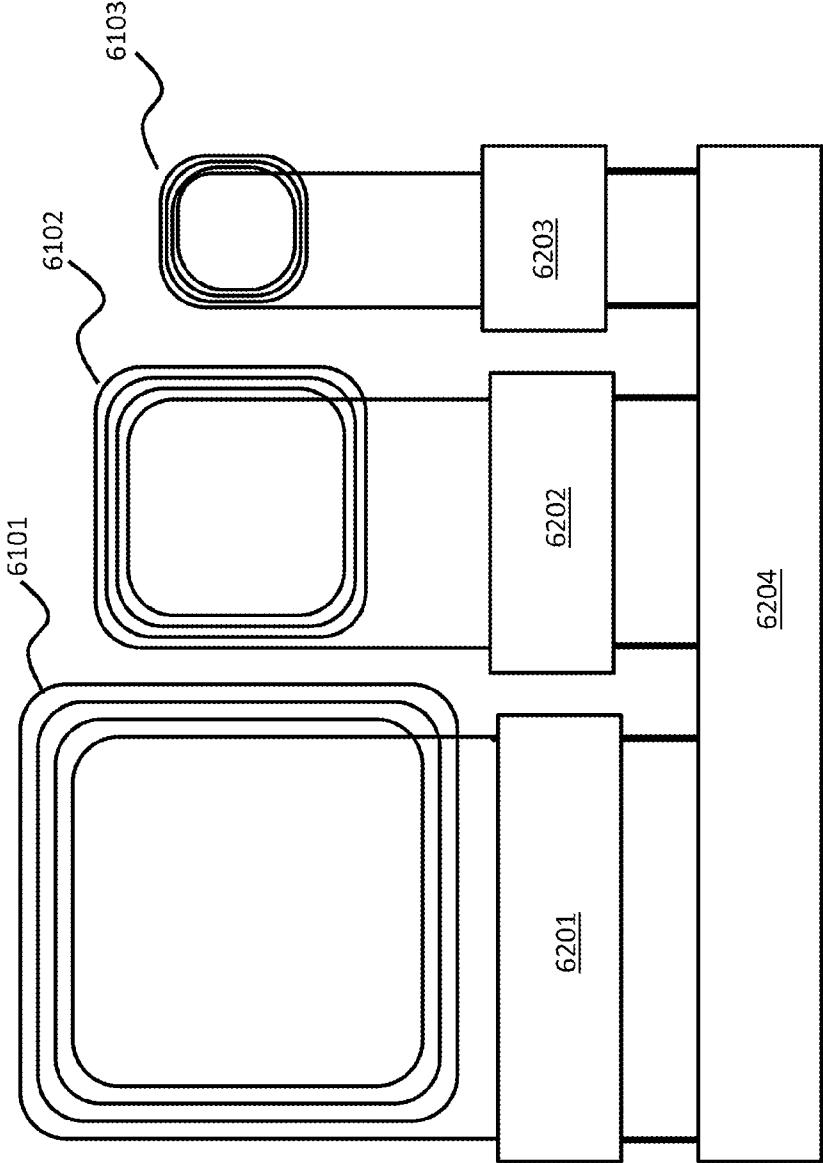

Fig. 19

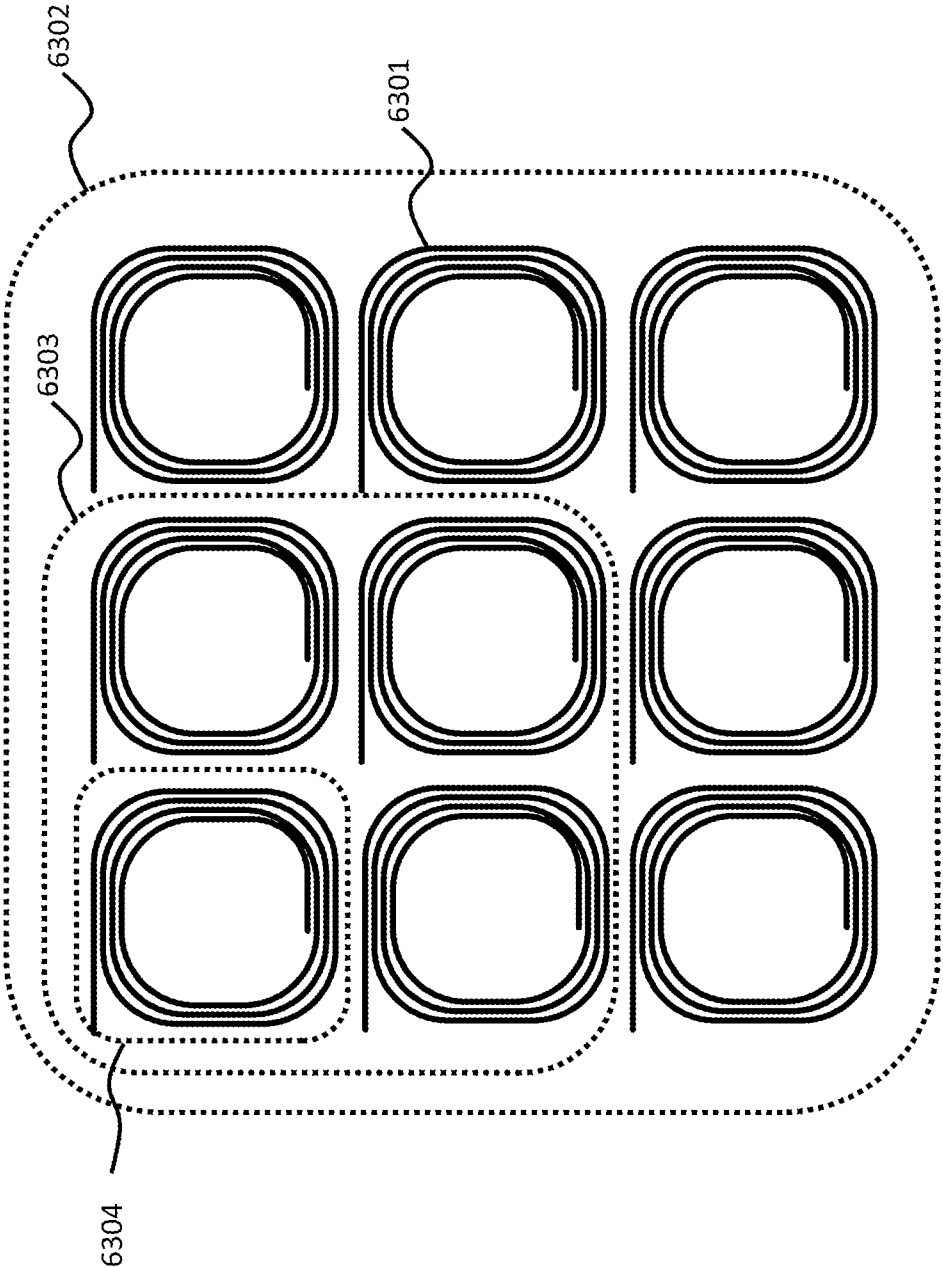
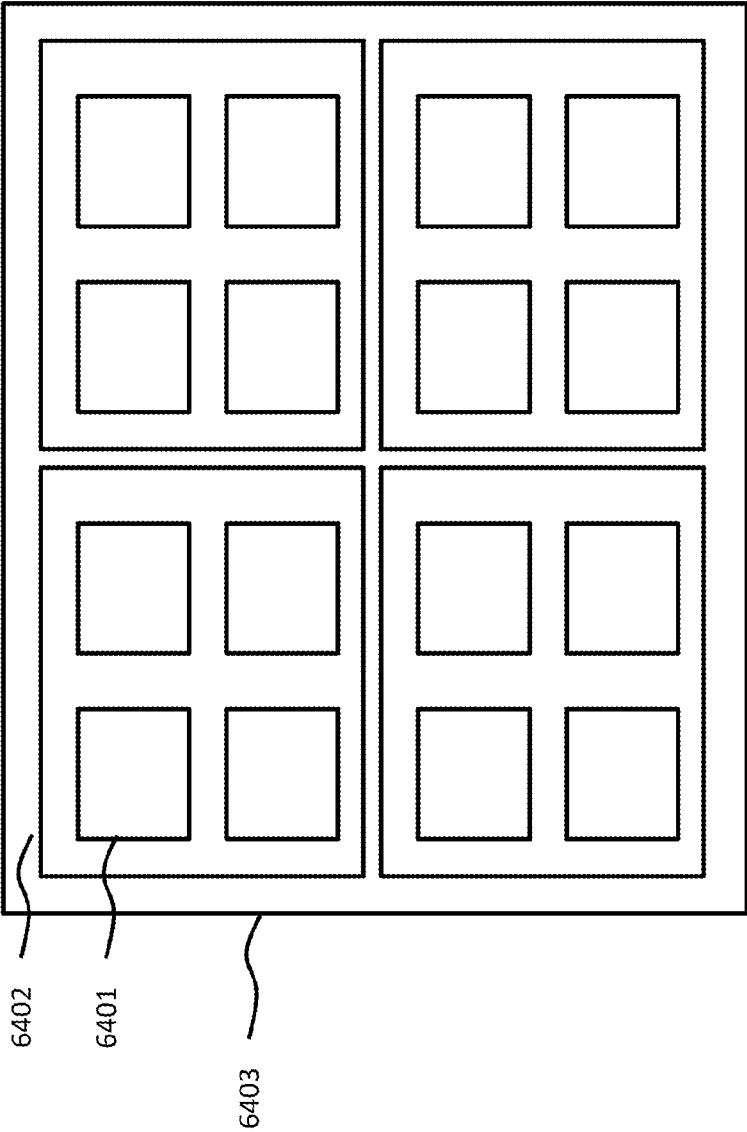

Fig. 20



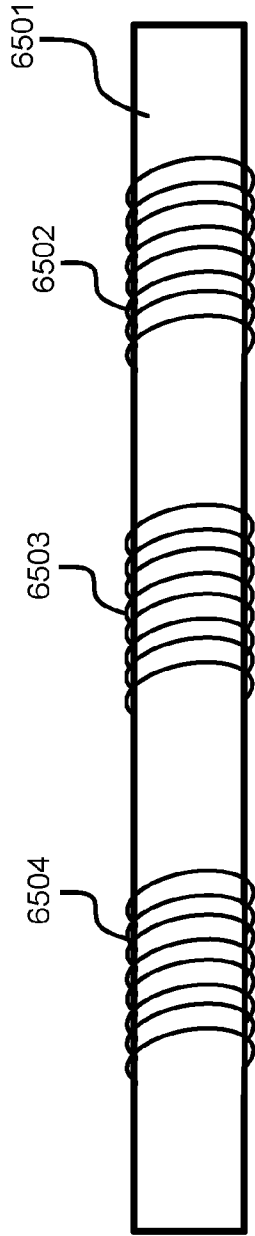

Fig. 21A

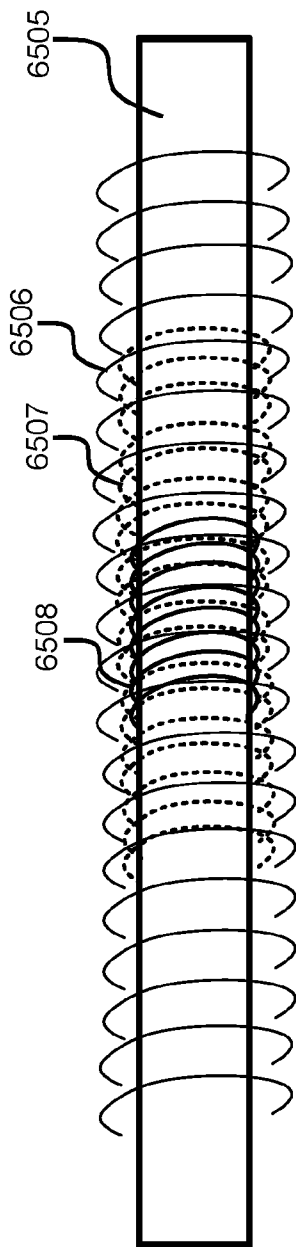

Fig. 21B

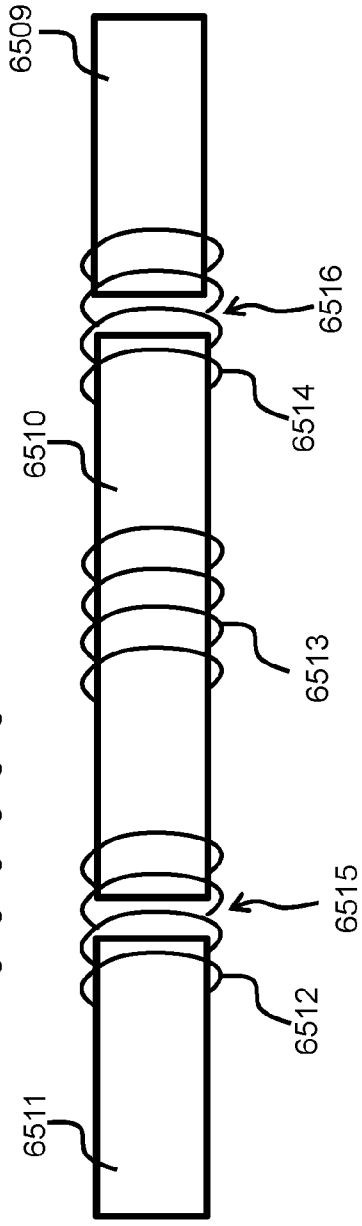

Fig. 21C

Fig. 22A

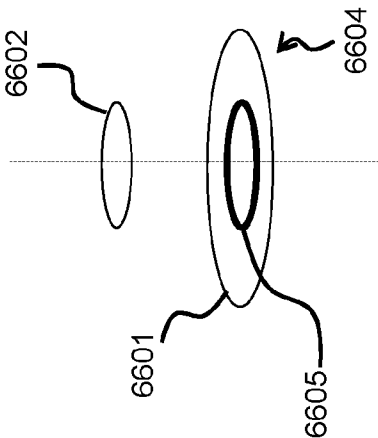

Fig. 22B

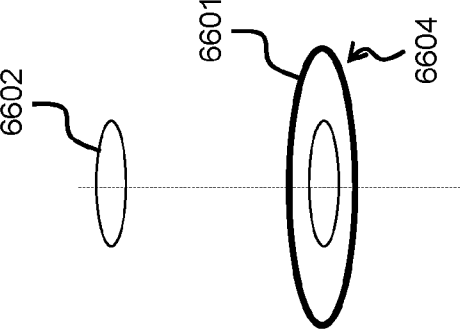

Fig. 22C

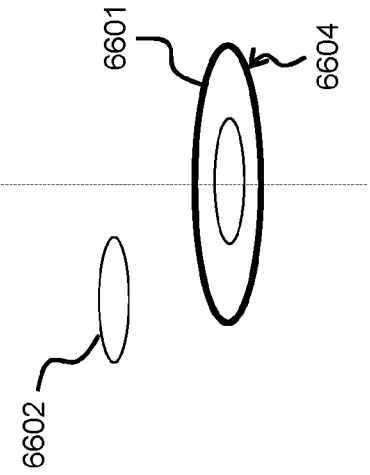
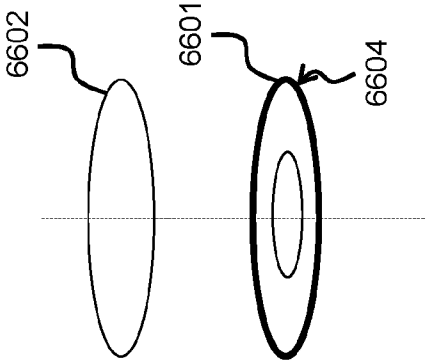

Fig. 22D



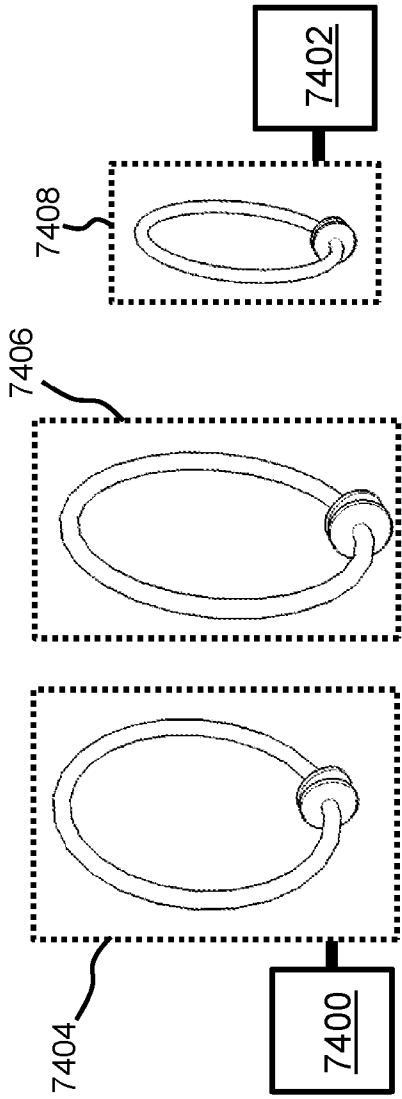

Fig. 23A

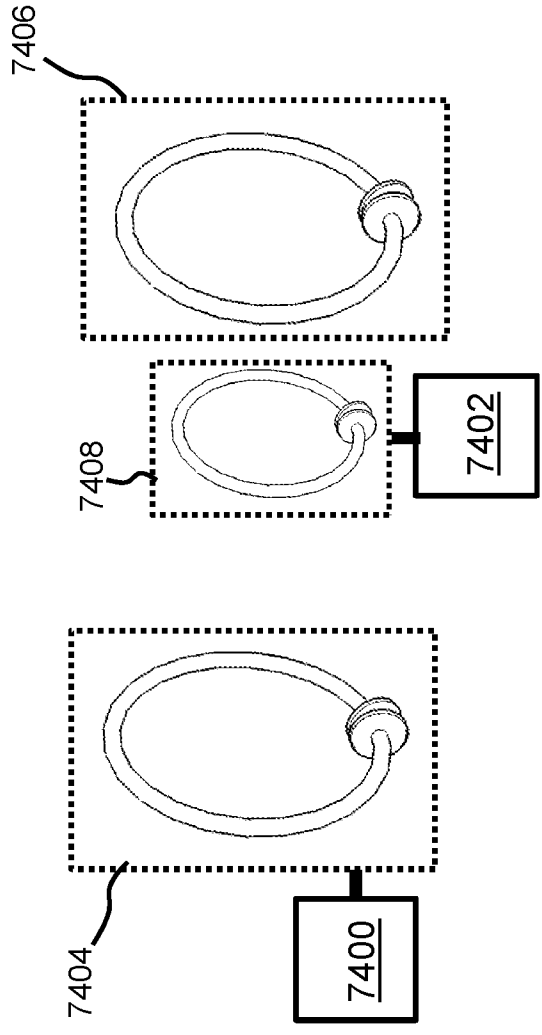

Fig. 23B

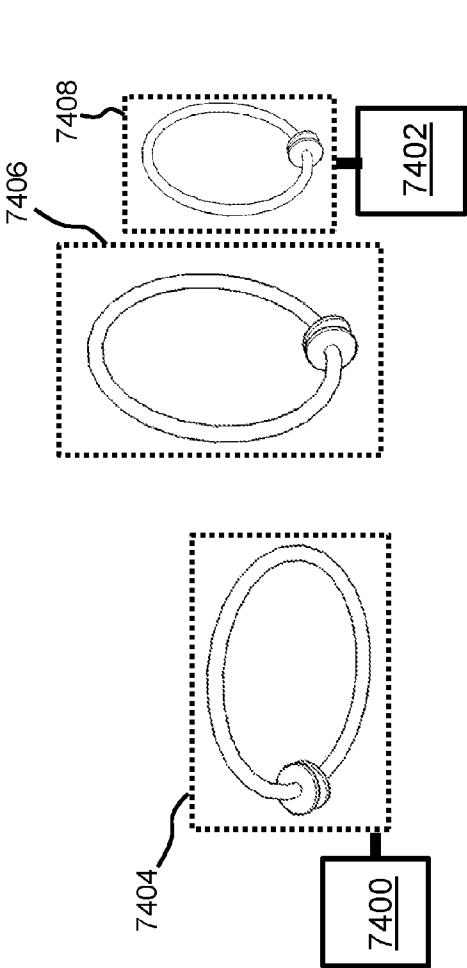

Fig. 24A

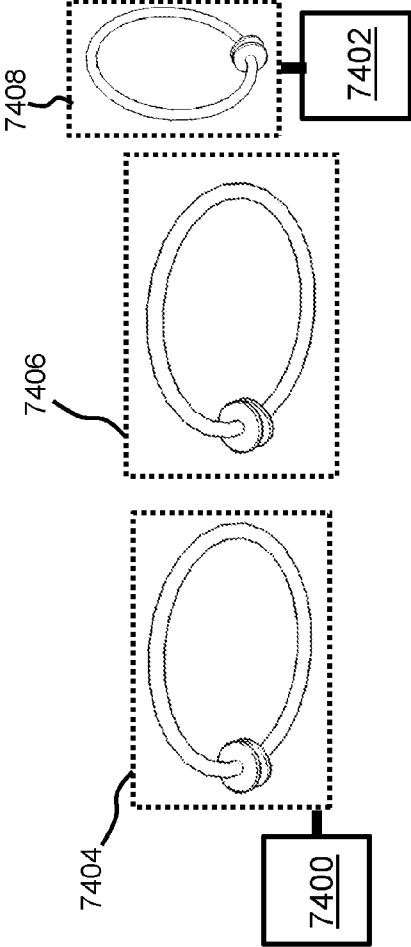

Fig. 24B

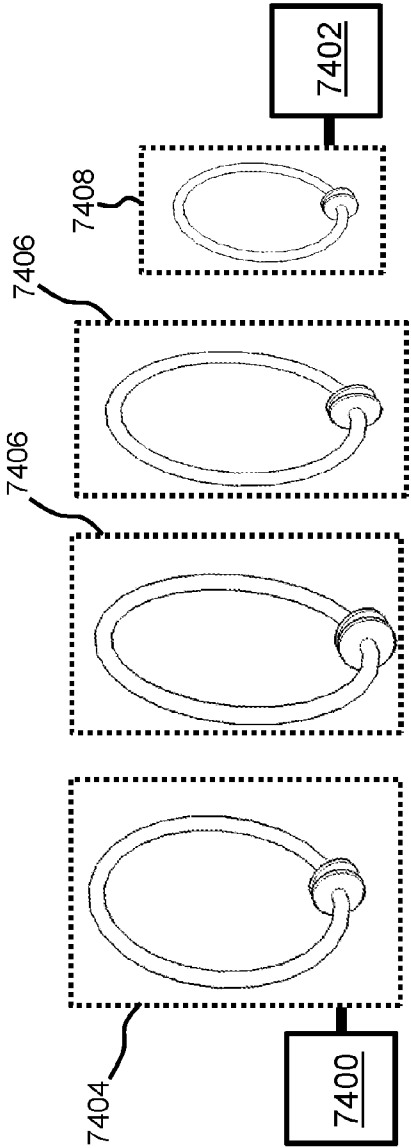

Fig. 25A

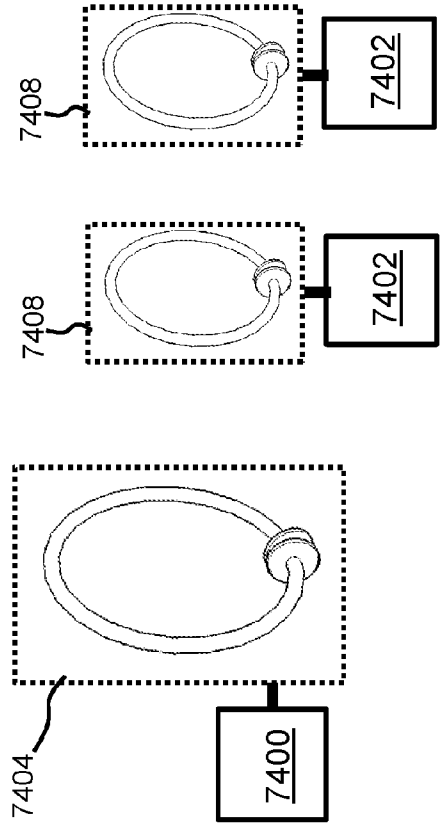

Fig. 25B

Fig. 26

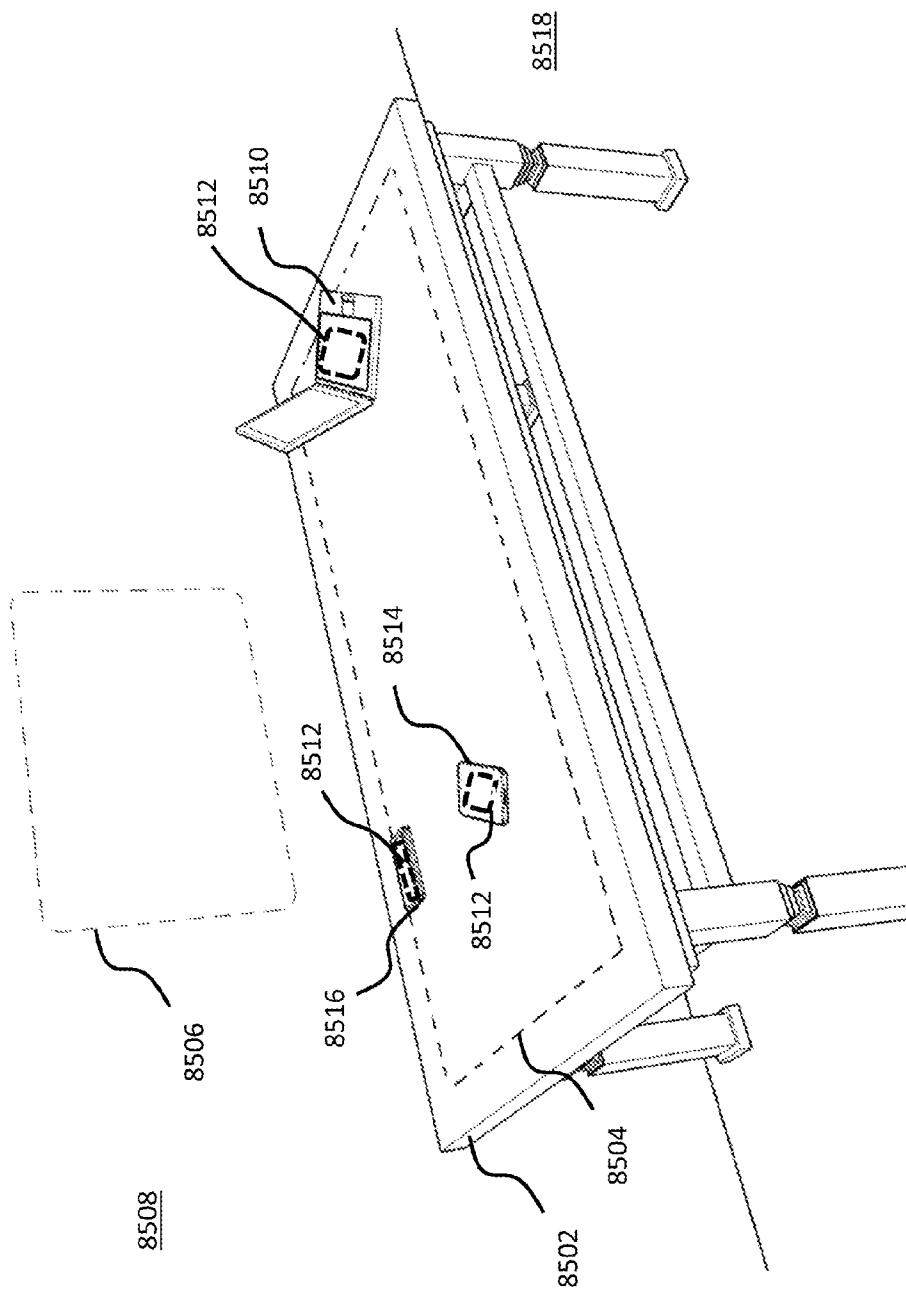

Fig. 27

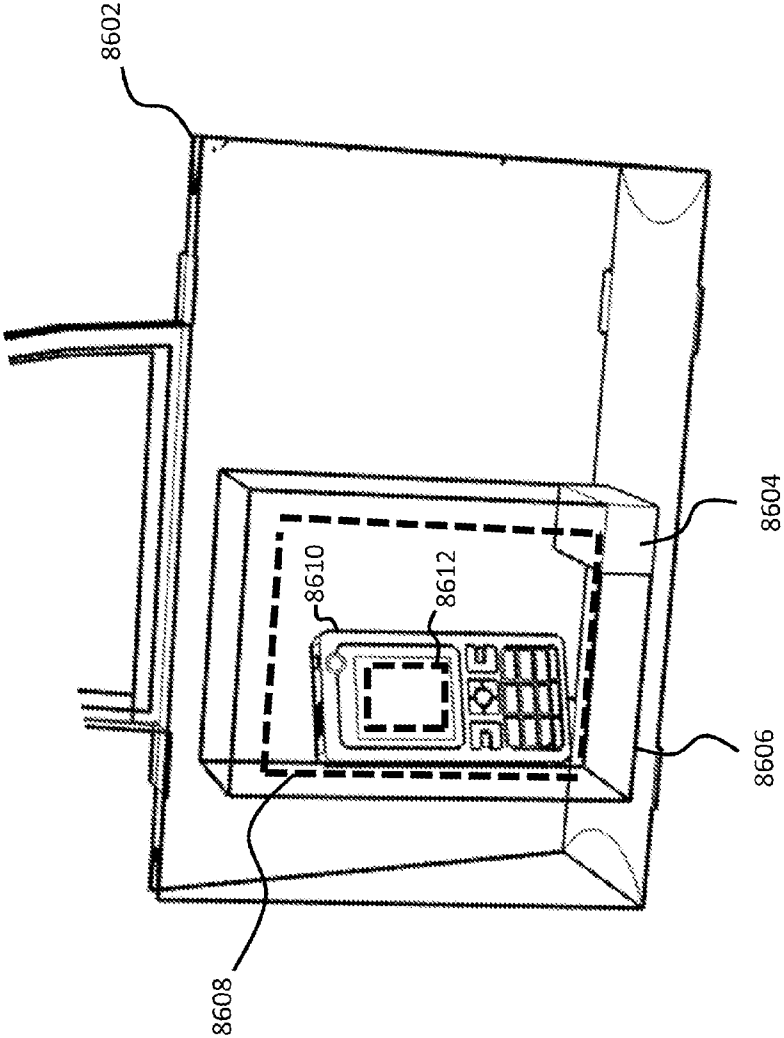
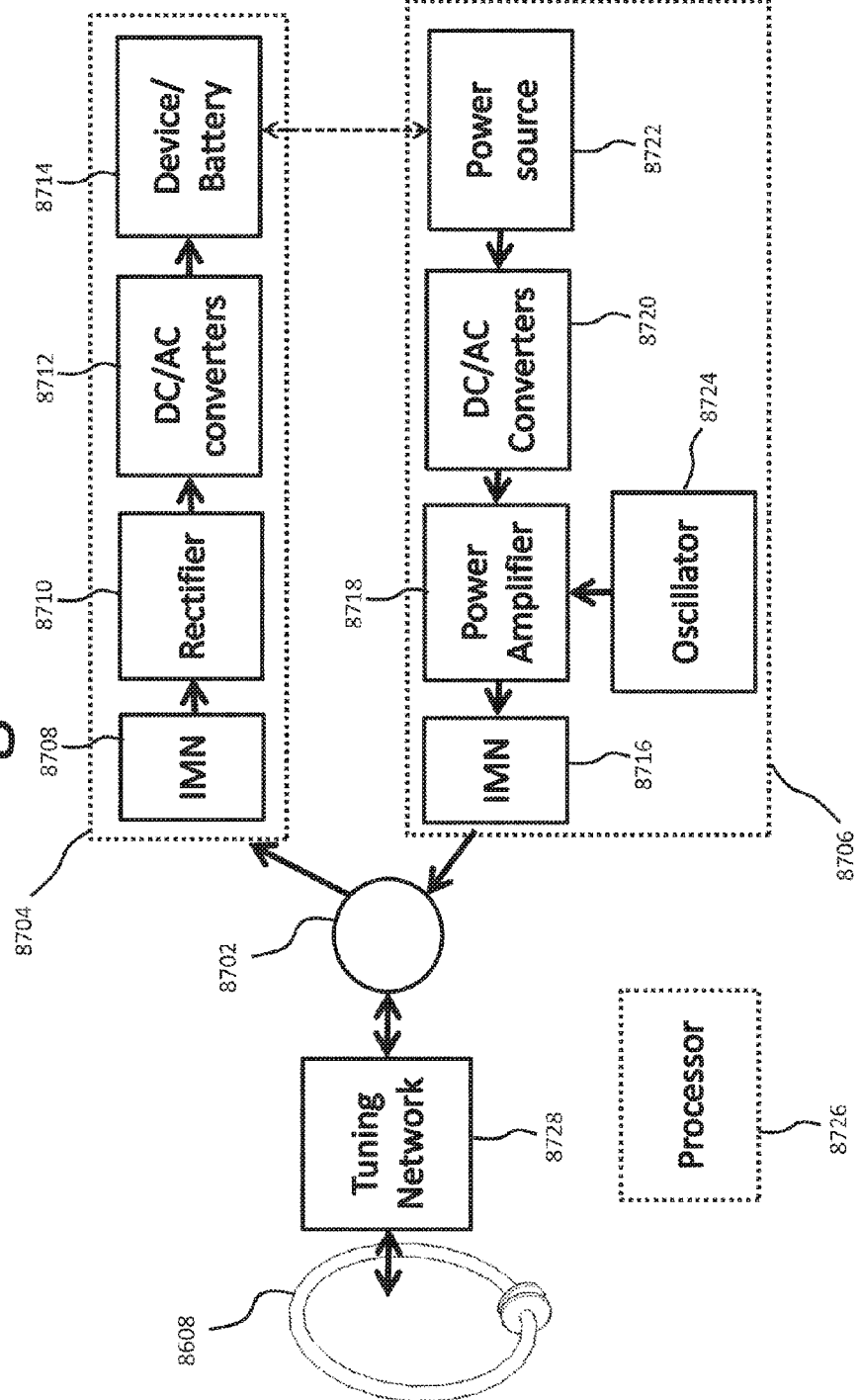

Fig. 28



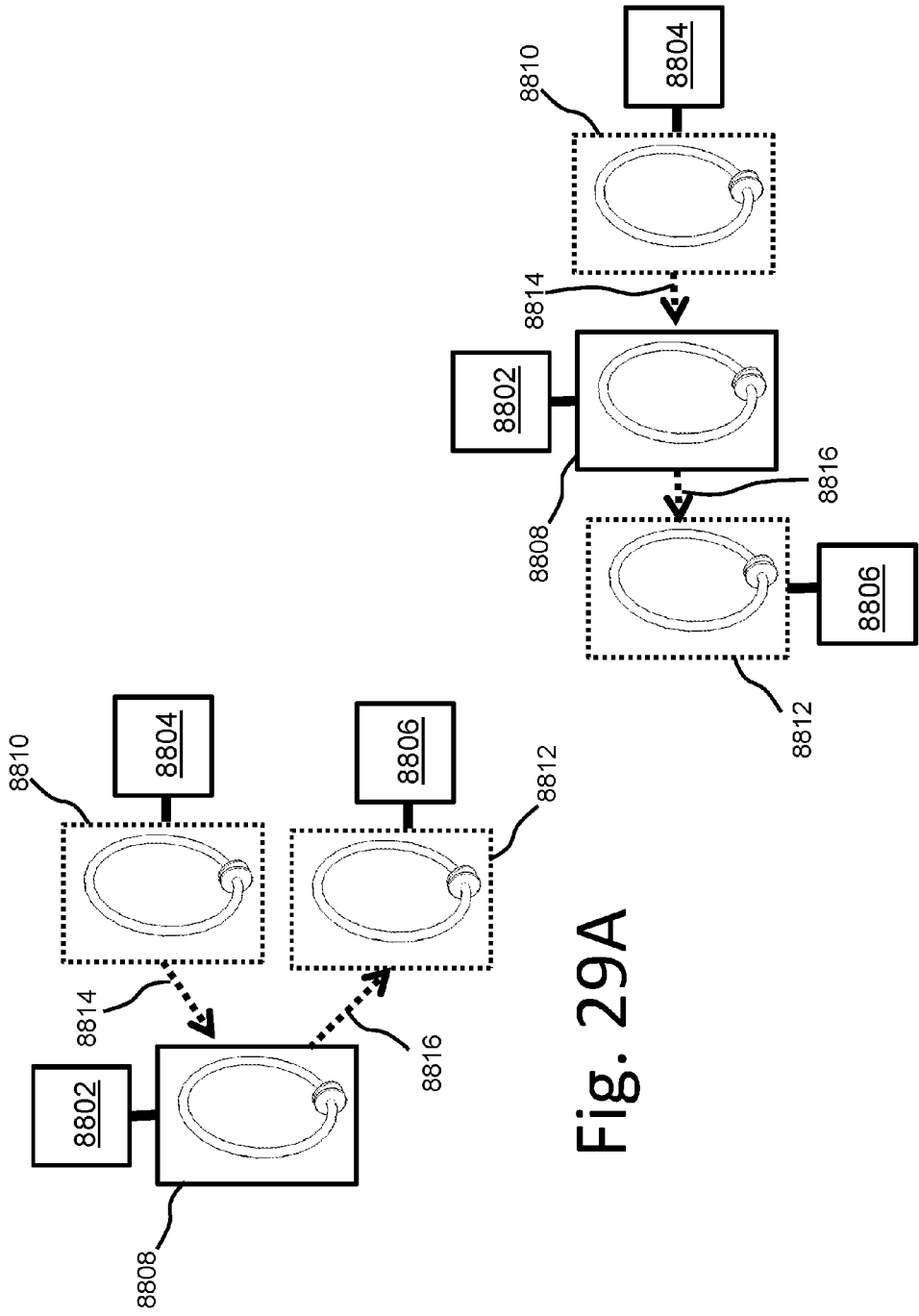
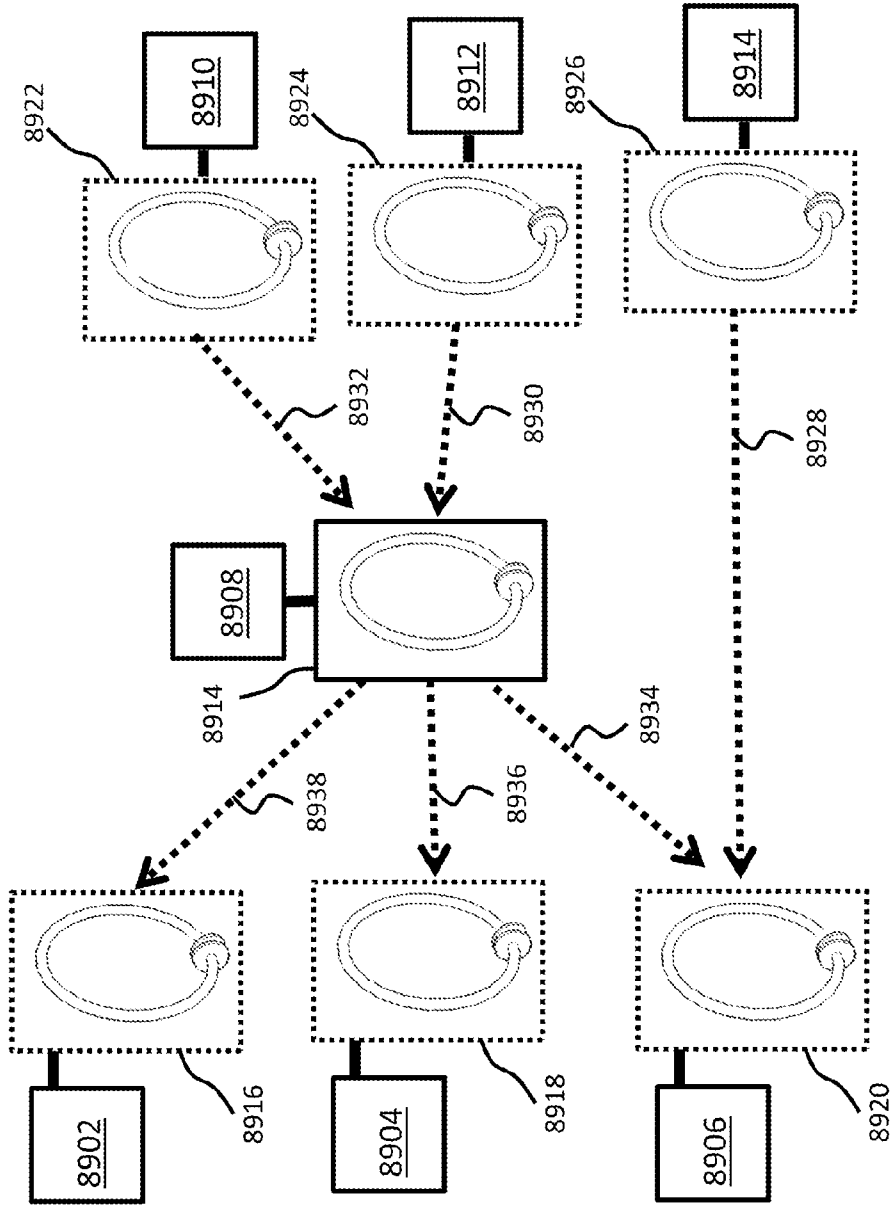

Fig. 29A

Fig. 29B

Fig. 30



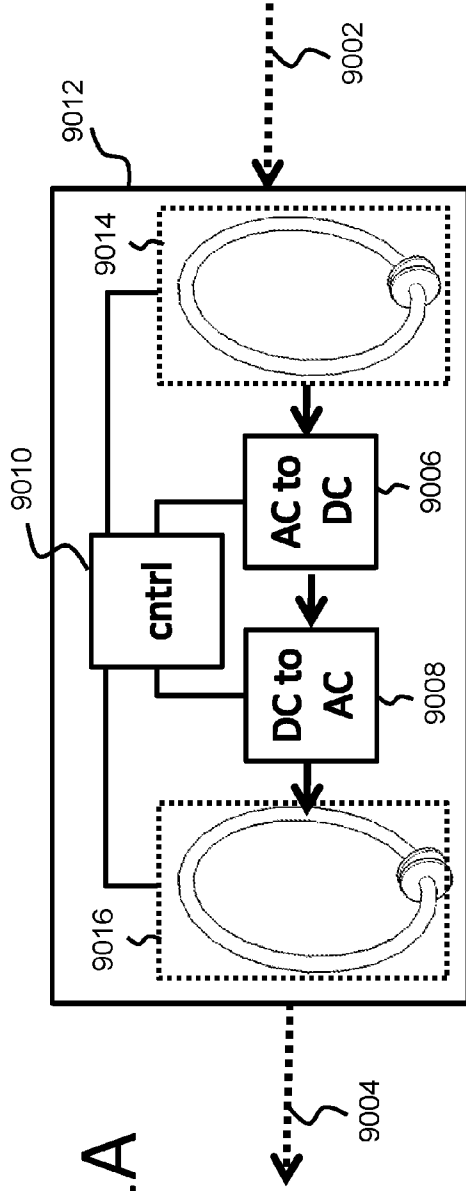

Fig. 31A

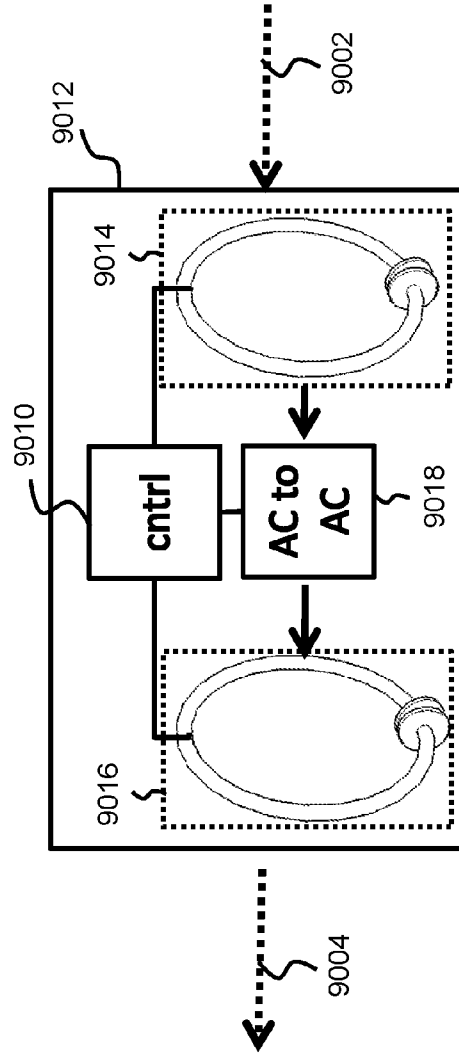

Fig. 31B

Fig. 32

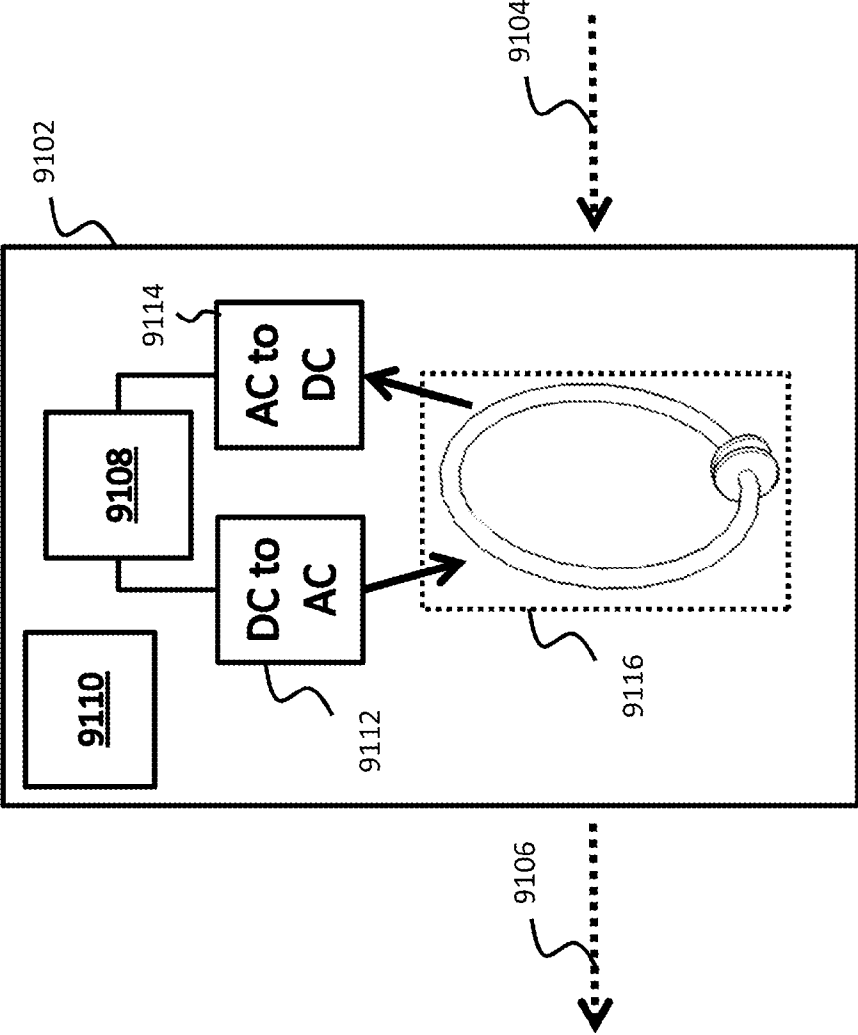

Fig. 33A

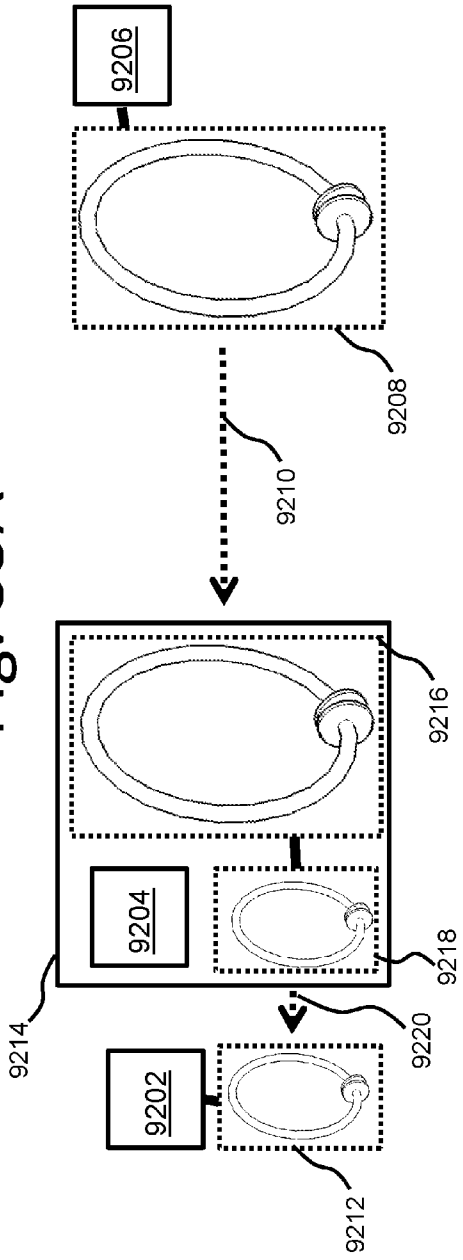
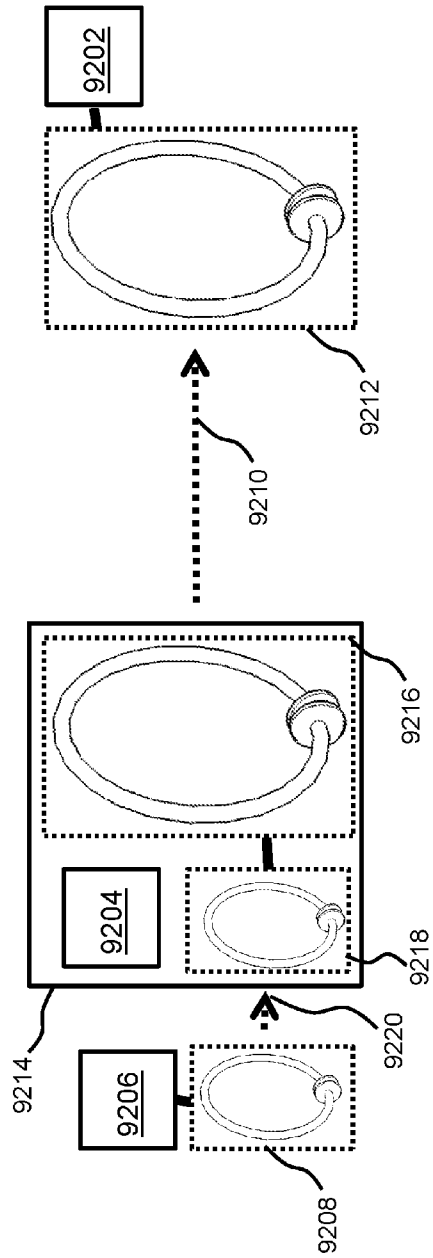

Fig. 33B



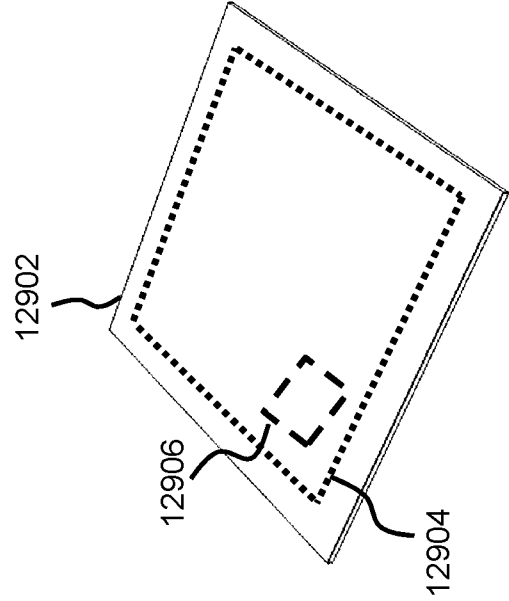

Fig. 34A

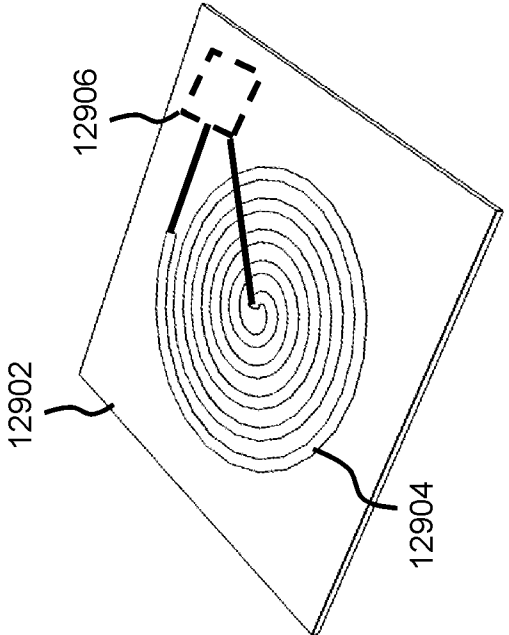

Fig. 34B

Fig. 35

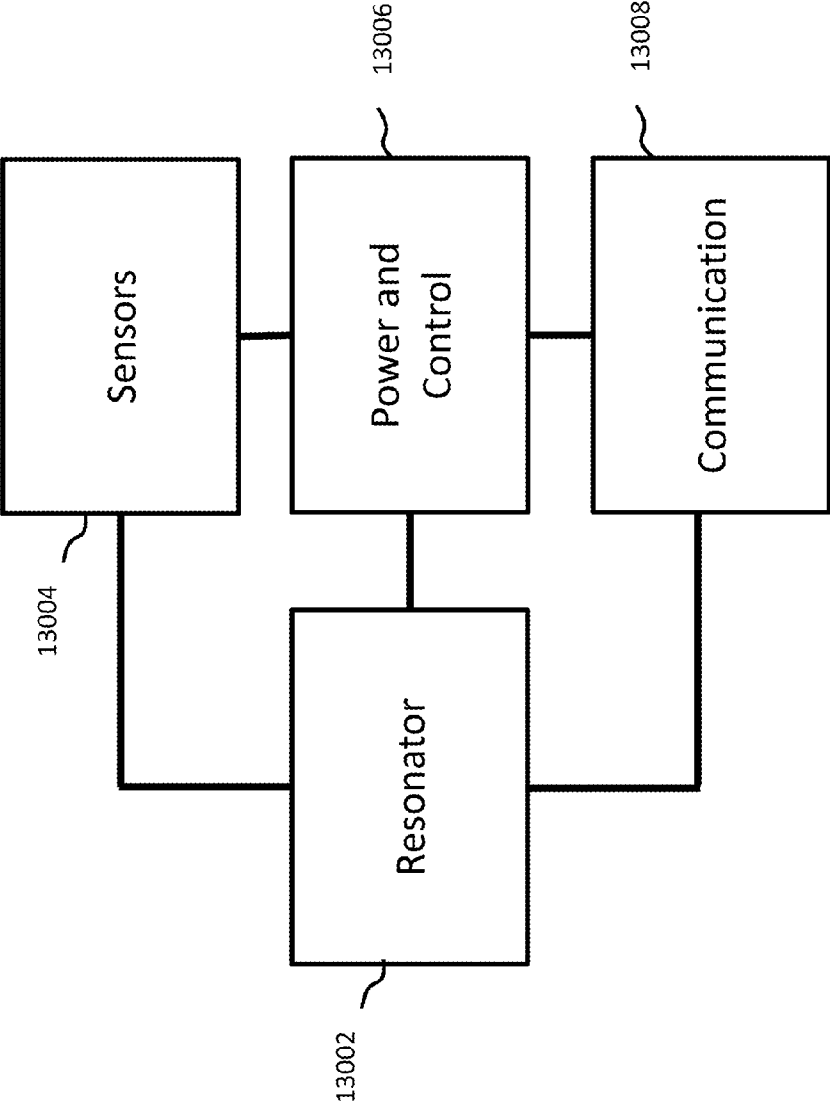

Fig. 36

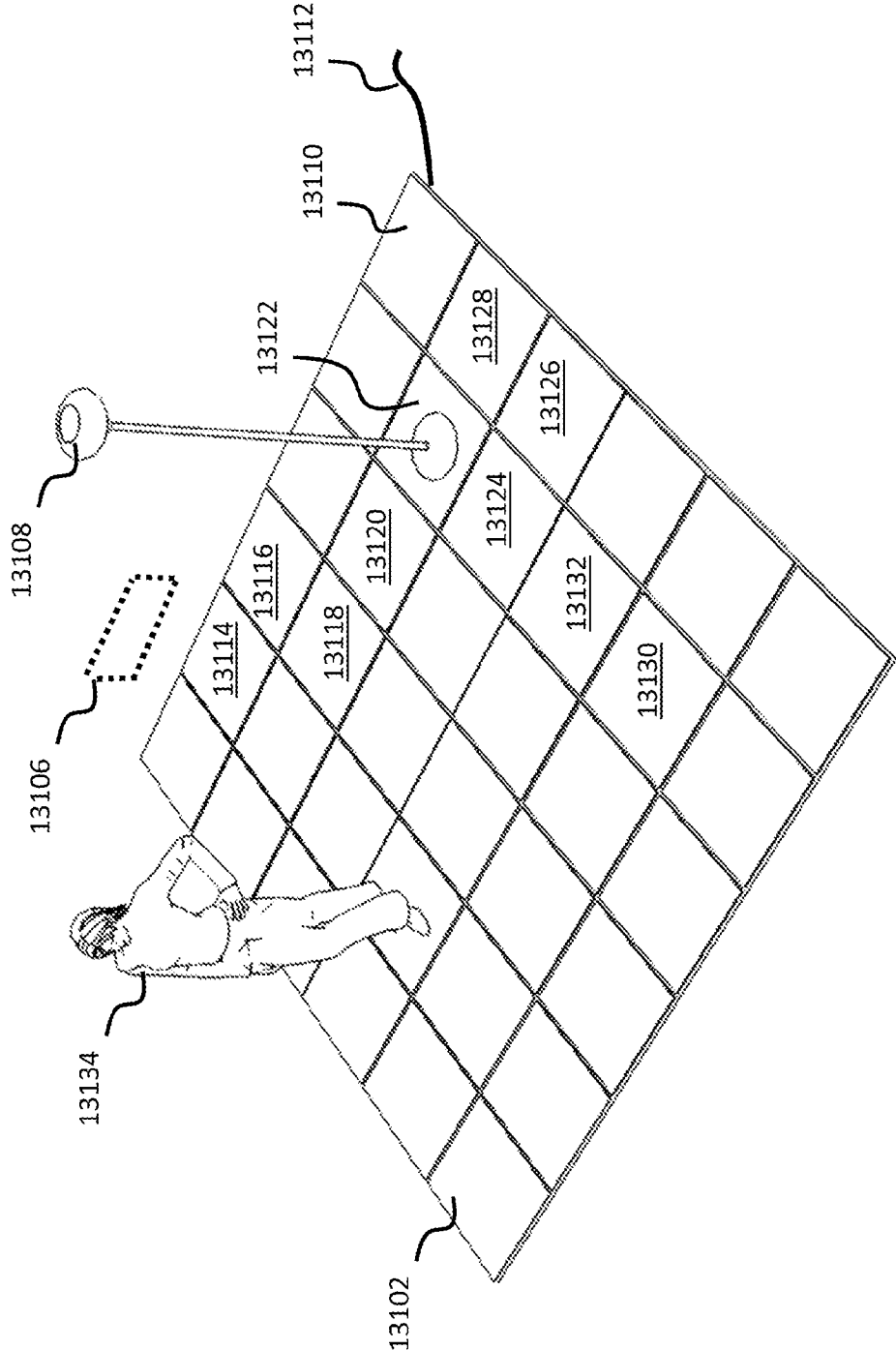

Fig. 37

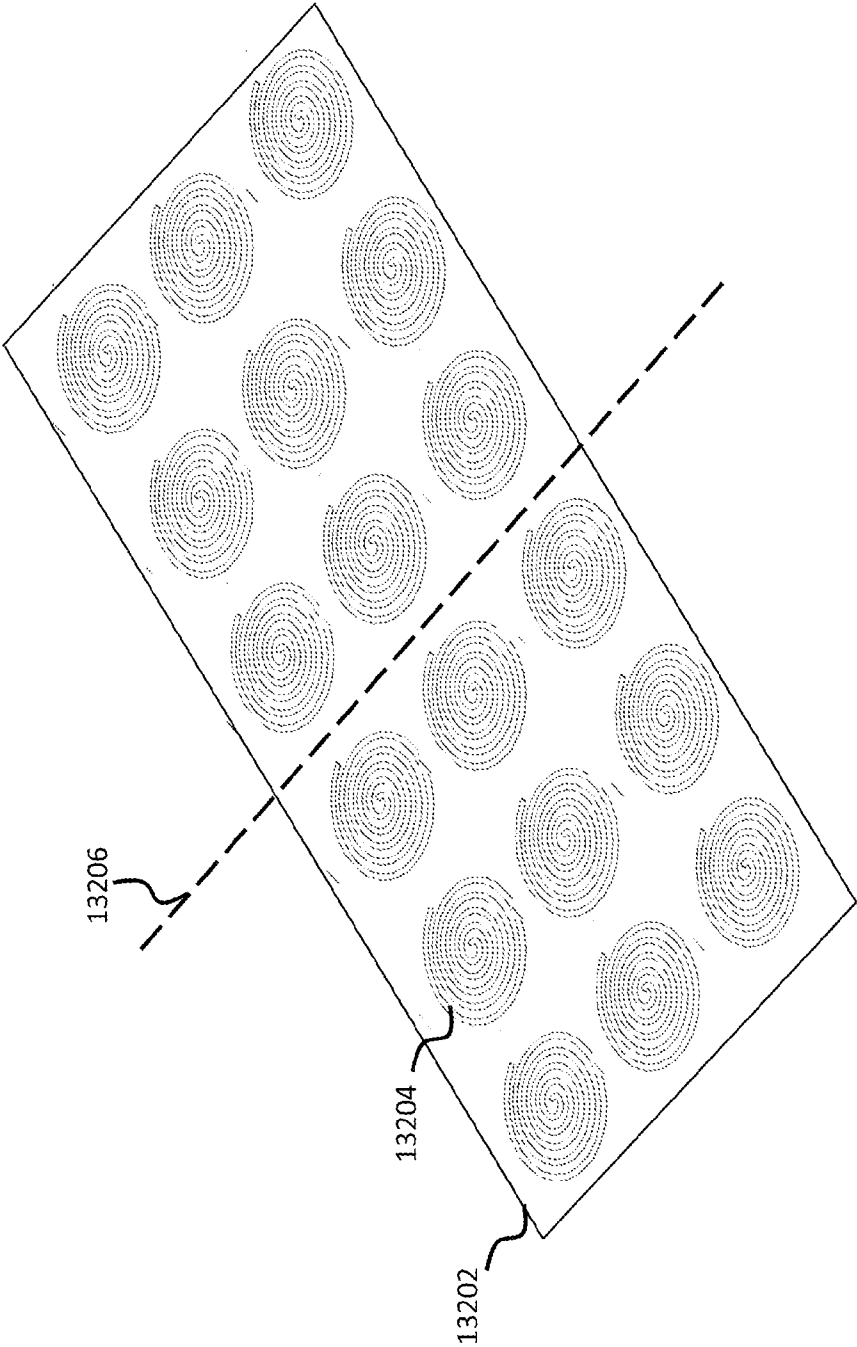

Fig. 38

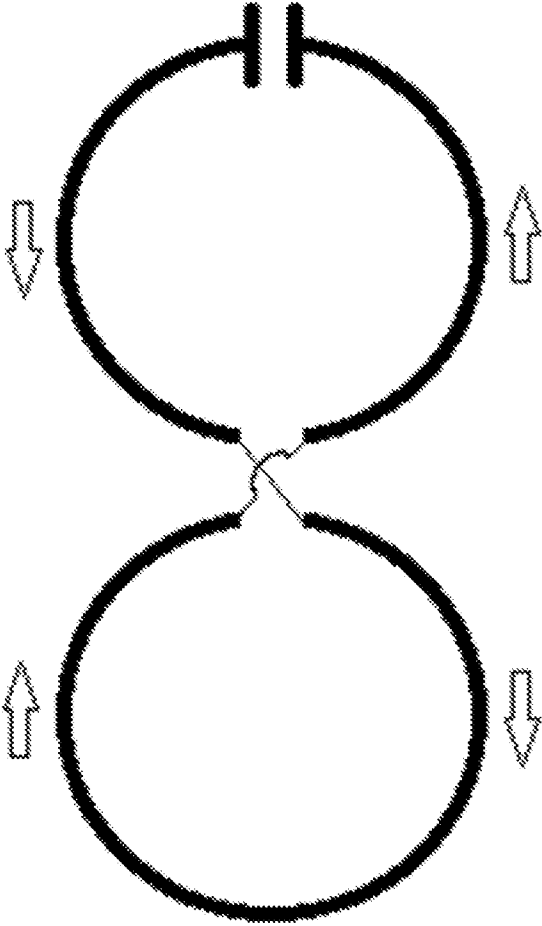

Fig. 39

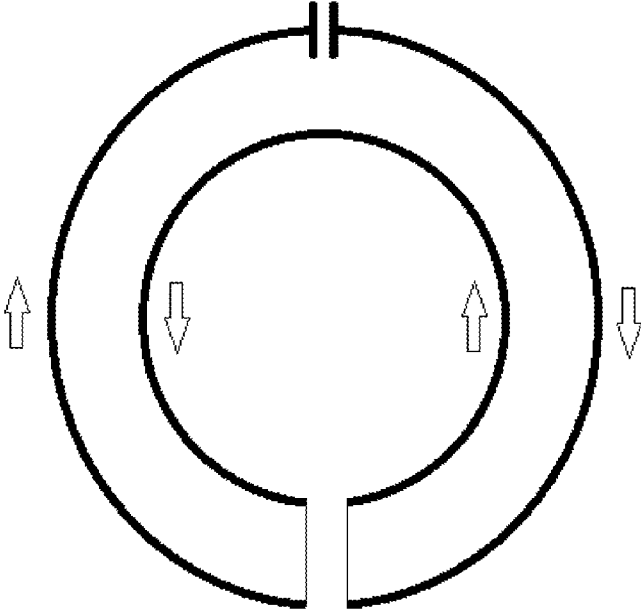

Fig. 40

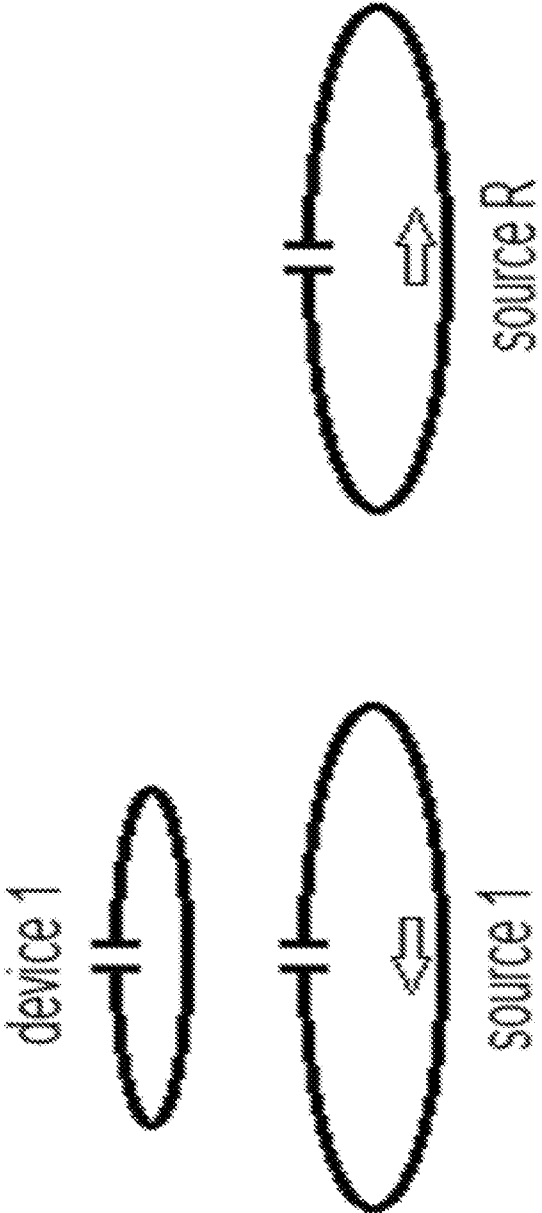

Fig. 41

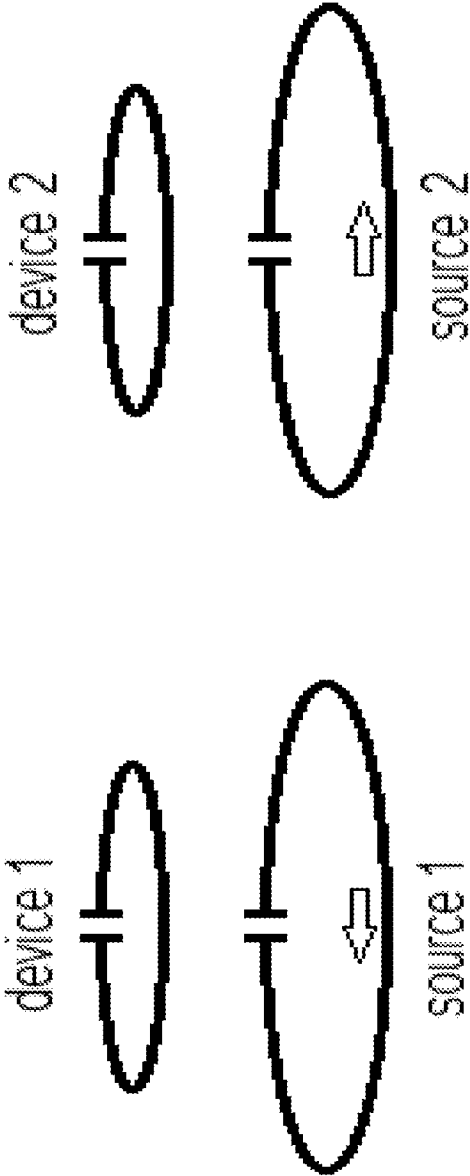

Fig. 42

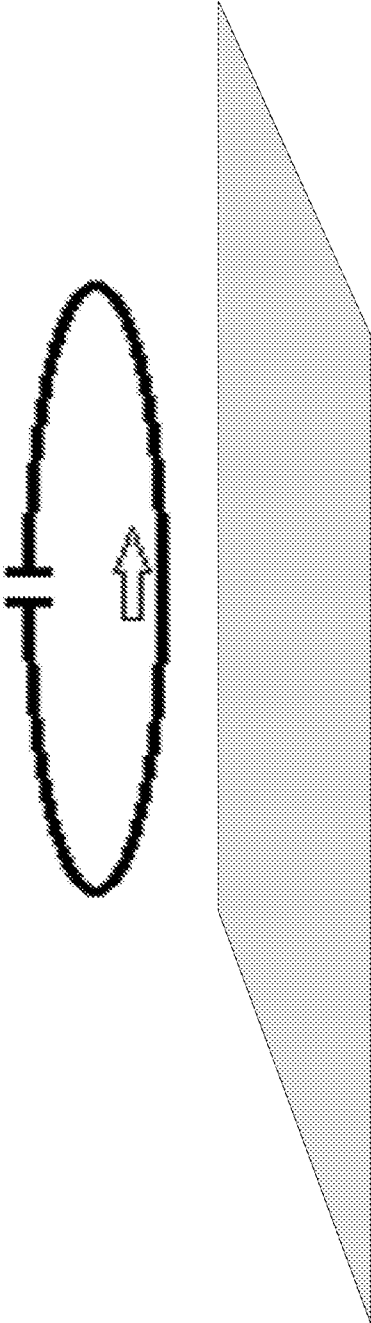

Fig. 43

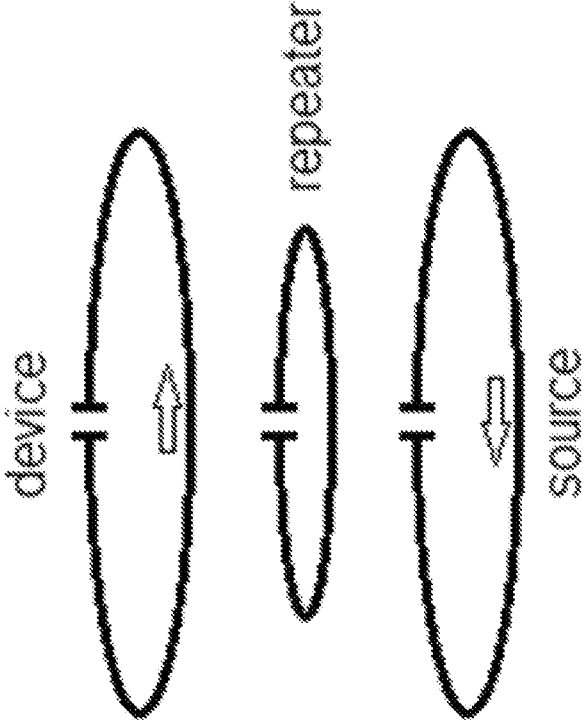

Fig. 44

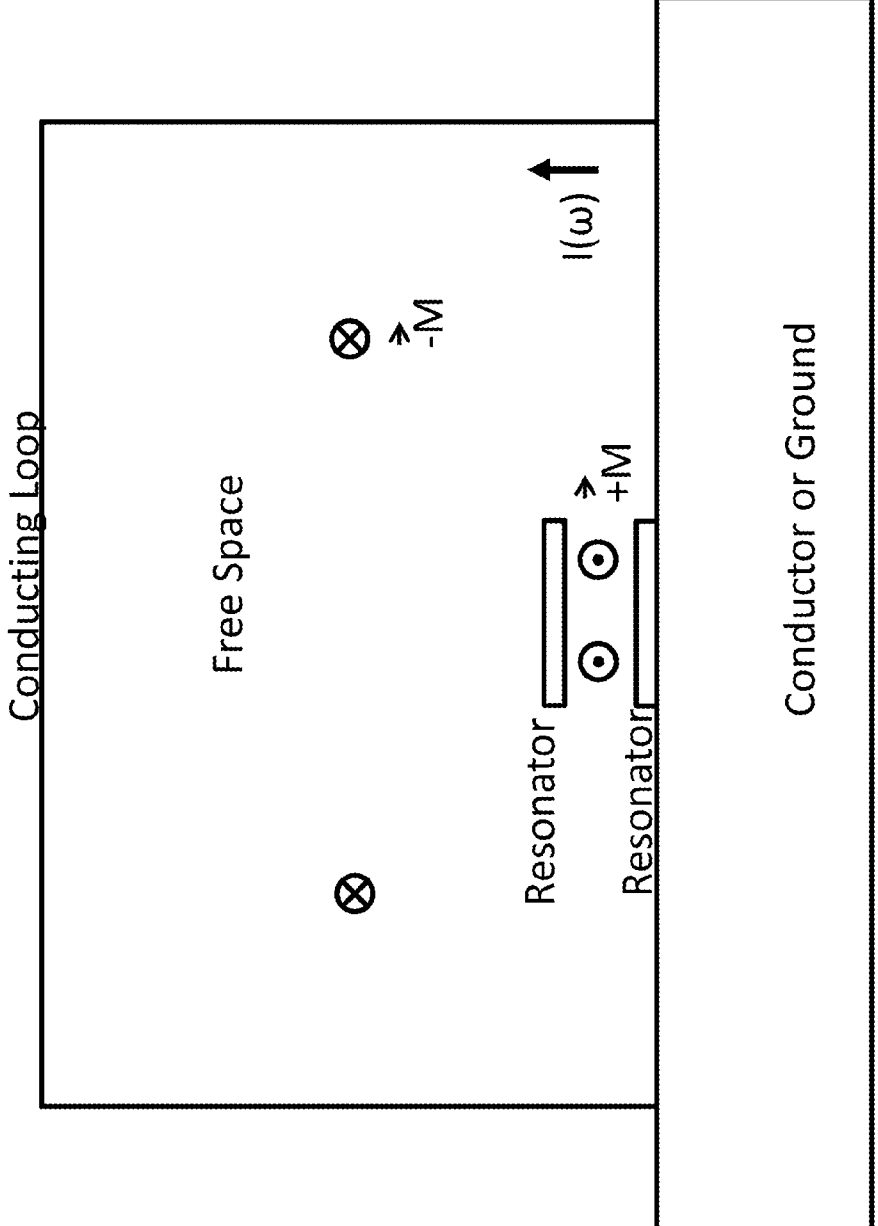

Fig. 45

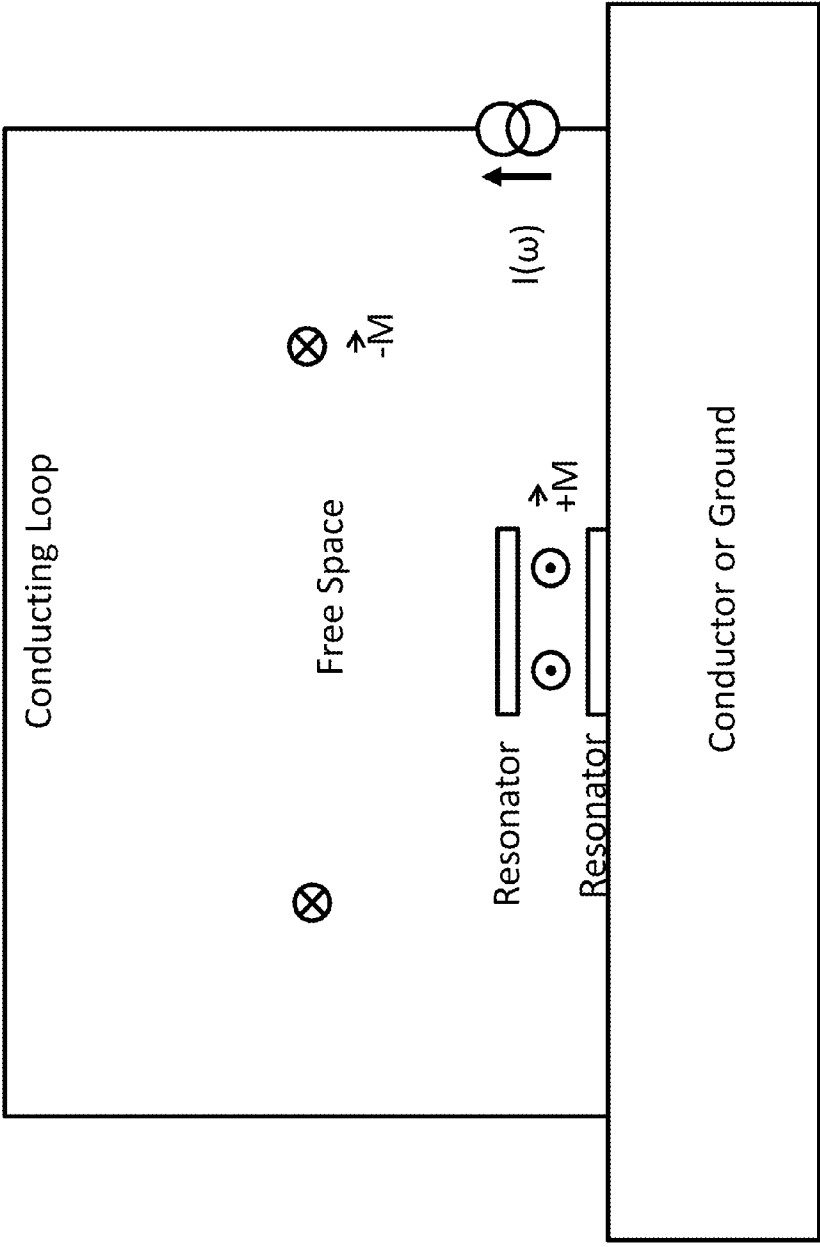

Fig. 46

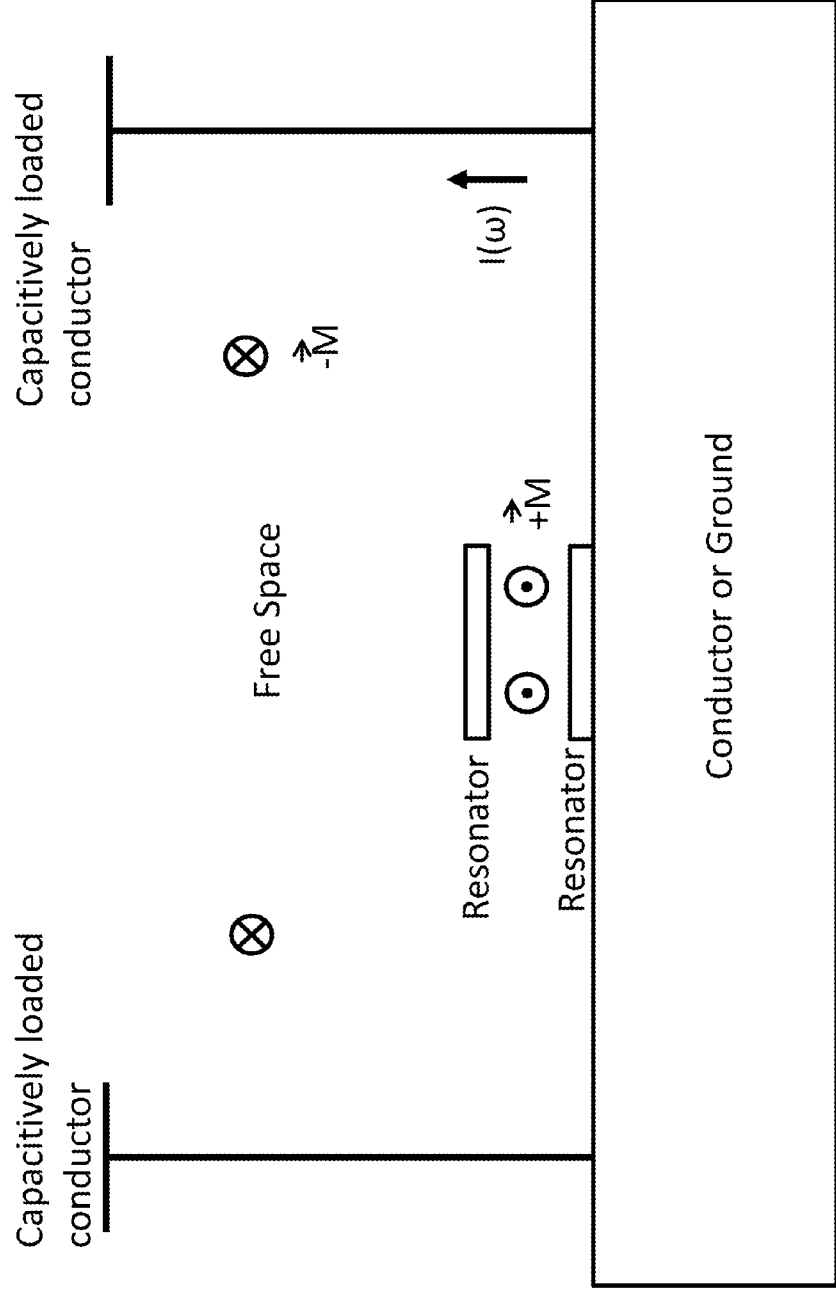

Fig. 47

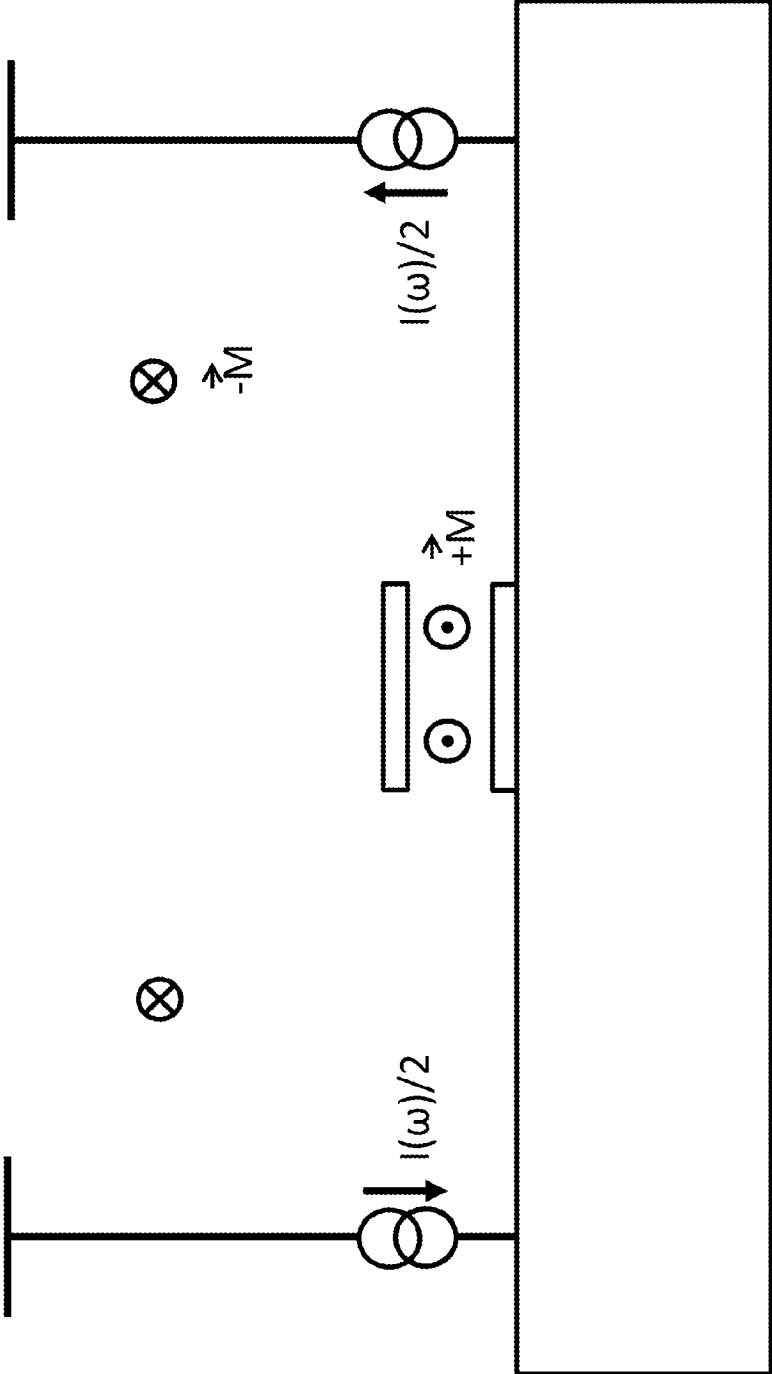

Fig. 48

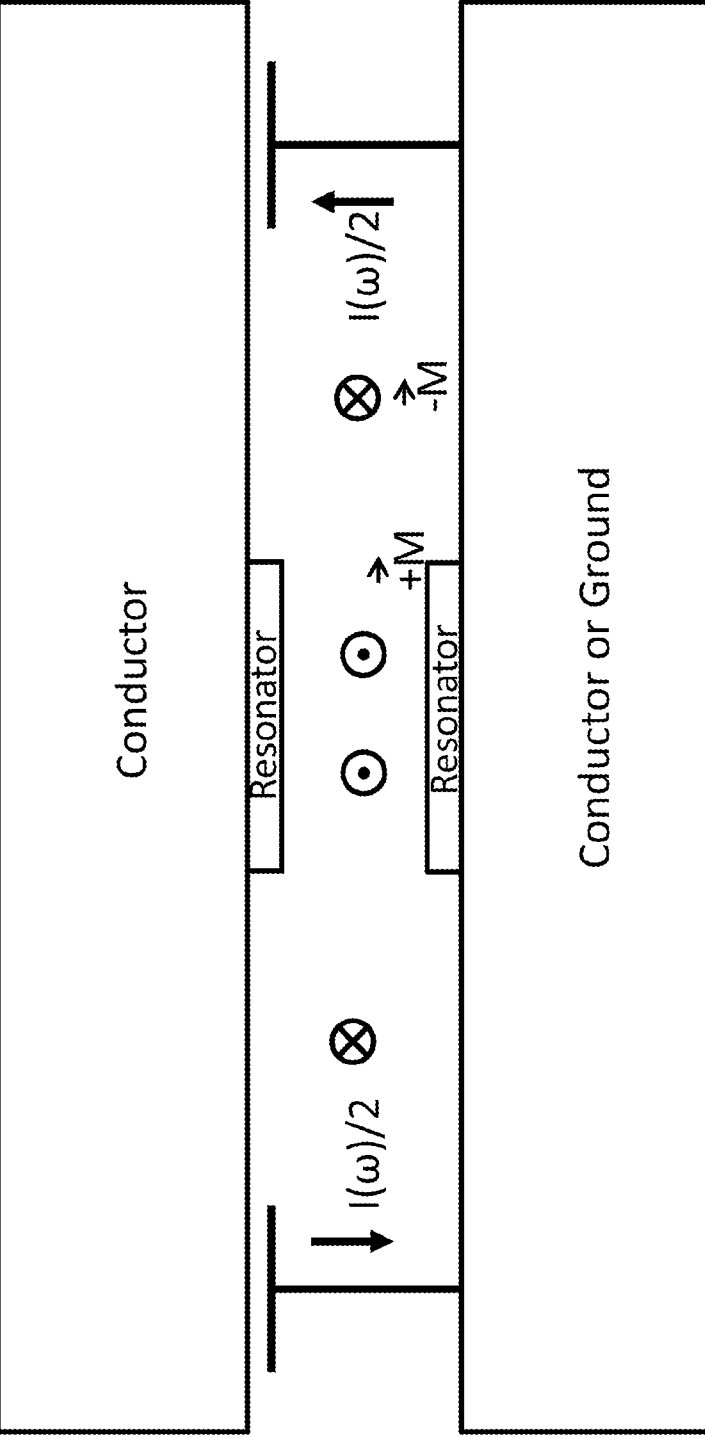
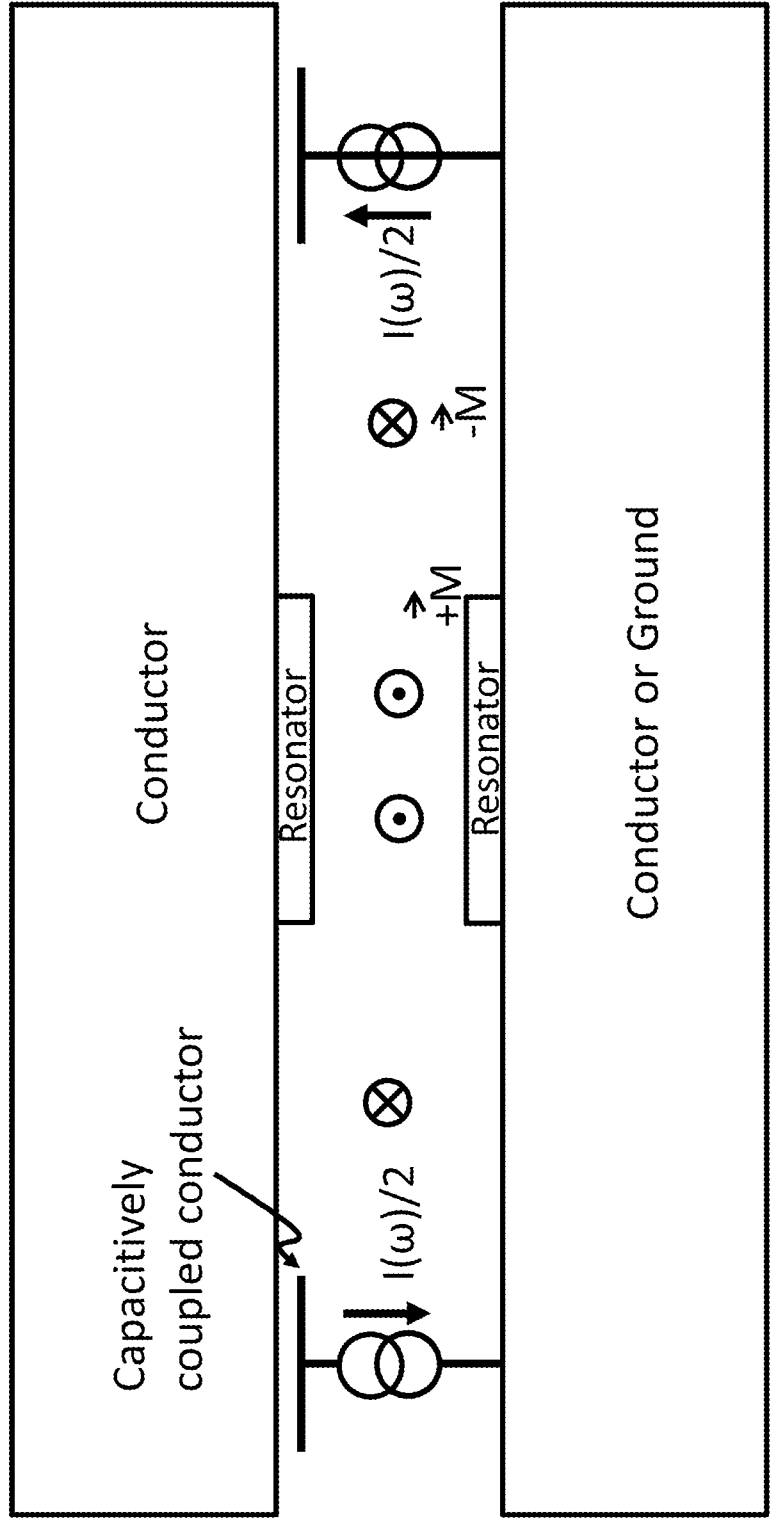

Fig. 49



WIRELESS ENERGY TRANSFER WITH REDUCED FIELDS

[0001] This application claims the benefit of U.S. provisional patent application Ser. No. 61/590,856 filed Jan. 26, 2012, which is hereby incorporated by reference in its entirety.

BACKGROUND

[0002] 1. Field

[0003] This disclosure relates to wireless energy transfer, methods, systems and apparatus to accomplish such transfer, and applications.

[0004] 2. Description of the Related Art

[0005] A need exists for methods and designs for energy distribution that is wire free but easy to deploy and configurable while may deliver sufficient power to be practical to power many household, industrial devices, and commercial devices.

SUMMARY

[0006] Resonators and resonator assemblies may be positioned to distribute wireless energy over a larger area in packaging applications. The wireless energy transfer resonators and components that may be used have been described in, for example, in commonly owned U.S. patent application Ser. No. 12/789,611 published on Sep. 23, 2010 as U.S. Pat. Pub. No. 2010/0237709 and entitled “RESONATOR ARRAYS FOR WIRELESS ENERGY TRANSFER,” and U.S. patent application Ser. No. 12/722,050 published on Jul. 22, 2010 as U.S. Pat. Pub. No. 2010/0181843 and entitled “WIRELESS ENERGY TRANSFER FOR REFRIGERATOR APPLICATION” the contents of which are incorporated in their entirety as if fully set forth herein.

[0007] Unless otherwise indicated, this disclosure uses the terms wireless energy transfer, wireless power transfer, wireless power transmission, and the like, interchangeably. Those skilled in the art will understand that a variety of system architectures may be supported by the wide range of wireless system designs and functionalities described in this application.

[0008] This disclosure references certain individual circuit components and elements such as capacitors, inductors, resistors, diodes, transformers, switches and the like; combinations of these elements as networks, topologies, circuits, and the like; and objects that have inherent characteristics such as “self-resonant” objects with capacitance or inductance distributed (or partially distributed, as opposed to solely lumped) throughout the entire object. It would be understood by one of ordinary skill in the art that adjusting and controlling variable components within a circuit or network may adjust the performance of that circuit or network and that those adjustments may be described generally as tuning, adjusting, matching, correcting, and the like. Other methods to tune or adjust the operating point of the wireless power transfer system may be used alone, or in addition to adjusting tunable components such as inductors and capacitors, or banks of inductors and capacitors. Those skilled in the art will recognize that a particular topology discussed in this disclosure can be implemented in a variety of other ways.

[0009] In accordance with an exemplary and non-limiting embodiment, a magnetic resonator comprises an inductor

comprising a conductive first loop having a first dipole moment and a conductive second loop having a second dipole moment wherein a direction of the first dipole moment is substantially opposite to a direction of the second dipole moment and at least one capacitor in series with at least one of the first loop and the second loop.

[0010] In accordance with another exemplary and non-limiting embodiment, a method comprises providing a plurality of conductive loops each having a dipole moment comprising a magnitude and a direction and selectively altering at least one dipole moment of at least one of the plurality of loops to produce a predetermined far field radiation level.

[0011] In accordance with another exemplary and non-limiting embodiment, a magnetic resonator comprises a plurality of conductive loops each having a dipole moment comprising a magnitude and a direction and a control system for adjusting the dipole moment of at least one of the plurality of loops to produce a predetermined far field radiation level.

[0012] In accordance with another exemplary and non-limiting embodiment, a wireless power source comprises at least one high-Q magnetic resonator for generating an oscillating magnetic field and at least one conducting plate positioned substantially perpendicular to the dipole moment of the resonator.

[0013] In accordance with another exemplary and non-limiting embodiment, a wireless power device comprises at least one high-Q magnetic resonator for generating a current in the presence of an oscillating magnetic field, and at least one conducting plate positioned substantially perpendicular to the dipole moment of the resonator.

[0014] Unless otherwise defined, all technical and scientific terms used herein have the same meaning as commonly understood by one of ordinary skill in the art to which this disclosure belongs. In case of conflict with publications, patent applications, patents, and other references mentioned or incorporated herein by reference, the present specification, including definitions, will control.

[0015] Any of the features described above may be used, alone or in combination, without departing from the scope of this disclosure. Other features, objects, and advantages of the systems and methods disclosed herein will be apparent from the following detailed description and figures.

BRIEF DESCRIPTION OF FIGURES

[0016] FIG. 1 is a system block diagram of wireless energy transfer configurations.

[0017] FIGS. 2A-2F are exemplary structures and schematics of simple resonator structures.

[0018] FIG. 3 is a block diagram of a wireless source with a single-ended amplifier.

[0019] FIG. 4 is a block diagram of a wireless source with a differential amplifier.

[0020] FIGS. 5A and 5B are block diagrams of sensing circuits.

[0021] FIGS. 6A, 6B, and 6C are block diagrams of a wireless source.

[0022] FIG. 7 is a plot showing the effects of a duty cycle on the parameters of an amplifier.

[0023] FIG. 8 is a simplified circuit diagram of a wireless power source with a switching amplifier.

[0024] FIG. 9 shows plots of the effects of changes of parameters of a wireless power source.

[0025] FIG. 10 shows plots of the effects of changes of parameters of a wireless power source.

[0026] FIGS. 11A, 11B, and 11C are plots showing the effects of changes of parameters of a wireless power source.

[0027] FIG. 12 shows plots of the effects of changes of parameters of a wireless power source.

[0028] FIG. 13 is a simplified circuit diagram of a wireless energy transfer system comprising a wireless power source with a switching amplifier and a wireless power device.

[0029] FIG. 14 shows plots of the effects of changes of parameters of a wireless power source.

[0030] FIG. 15A is a plot of wireless power transfer efficiency between a fixed size device resonator and different sized source resonators as a function of separation distance and FIG. 15B is a diagram of the resonator configuration used for generating the plot.

[0031] FIG. 16A is a plot of wireless power transfer efficiency between a fixed size device resonator and different sized source resonators as a function of lateral offset and FIG. 16B is a diagram of the resonator configuration used for generating the plot.

[0032] FIG. 17 is a diagram of a conductor arrangement of an exemplary system embodiment.

[0033] FIG. 18 is a diagram of another conductor arrangement of an exemplary system embodiment.

[0034] FIG. 19 is a diagram of an exemplary system embodiment of a source comprising an array of equally sized resonators.

[0035] FIG. 20 is a diagram of an exemplary system embodiment of a source comprising an array of multi-sized resonators.

[0036] FIG. 21A-21C are diagrams of exemplary embodiments of adjustable size sources comprising planar resonator structures.

[0037] FIGS. 22A-22D are diagrams showing usage scenarios for an adjustable source size.

[0038] FIGS. 23A and 23B are diagrams showing two resonator configurations with repeater resonators.

[0039] FIGS. 24A and 24B are diagrams showing two resonator configurations with repeater resonators.

[0040] FIG. 25A is a diagram showing a configuration with two repeater resonators, and

[0041] FIG. 25B is a diagram showing a resonator configuration with a device resonator acting as a repeater resonator.

[0042] FIG. 26 is a diagram of a system utilizing a repeater resonator with a desk environment.

[0043] FIG. 27 is a diagram of a system utilizing a resonator that may be operated in multiple modes.

[0044] FIG. 28 is a circuit block diagram of the power and control circuitry of a resonator configured to have multiple modes of operation.

[0045] FIG. 29A is a block diagram of a configuration of a system utilizing a wireless power converter, and FIG. 29B is a block diagram of a configuration of a system utilizing a wireless power converter that may also function as a repeater.

[0046] FIG. 30 is a block diagram showing different configurations and uses of a wireless power converter.

[0047] FIG. 31A is a block diagram of a wireless power converter that uses two separate resonators and a AC to DC converter, and FIG. 31B is a block diagram of a wireless power converter that uses two separate resonators and an AC to AC converter.

[0048] FIG. 32 is a circuit block diagram of a wireless power converter utilizing one resonator.

[0049] FIGS. 33A and 33B are circuit diagrams of system configurations utilizing a wireless power converter with differently sized resonators.

[0050] FIG. 34A and FIG. 34B are diagrams of embodiments of a wireless power enabled floor tile.

[0051] FIG. 35 is a block diagram of an embodiment of a wireless power enabled floor tile.

[0052] FIG. 36 is a diagram of a wireless power enables floor system.

[0053] FIG. 37 is a diagram of a cuttable sheet of resonators.

[0054] FIG. 38 is a diagram of a quadrupole resonator loop.

[0055] FIG. 39 is a diagram of a quadrupole resonator loop.

[0056] FIG. 40 is a diagram of a system with dipole cancellation using an additional source resonator.

[0057] FIG. 41 is a diagram of a system with dipole cancellation using an additional source and device resonator.

[0058] FIG. 42 is a diagram of a resonator with dipole cancellation using a conductor shield.

[0059] FIG. 43 is a diagram of a system with dipole cancellation using a repeater resonator.

[0060] FIG. 44 is a diagram of a system with dipole cancellation using a conducting loop.

[0061] FIG. 45 is a diagram of a system with dipole cancellation using a conducting loop.

[0062] FIG. 46 is a diagram of a system with dipole cancellation.

[0063] FIG. 47 is a diagram of a system with dipole cancellation.

[0064] FIG. 48 is a diagram of a system with dipole cancellation.

[0065] FIG. 49 is a diagram of a system with dipole cancellation.

DETAILED DESCRIPTION

[0066] As described above, this disclosure relates to wireless energy transfer using coupled electromagnetic resonators. However, such energy transfer is not restricted to electromagnetic resonators, and the wireless energy transfer systems described herein are more general and may be implemented using a wide variety of resonators and resonant objects.

[0067] As those skilled in the art will recognize, important considerations for resonator-based power transfer include resonator efficiency and resonator coupling. Extensive discussion of such issues, e.g., coupled mode theory (CMT), coupling coefficients and factors, quality factors (also referred to as Q-factors), and impedance matching is provided, for example, in U.S. patent application Ser. No. 12/789,611 published on Sep. 23, 2010 as US 20100237709 and entitled "RESONATOR ARRAYS FOR WIRELESS ENERGY TRANSFER," and U.S. patent application Ser. No. 12/722,050 published on Jul. 22, 2010 as US 20100181843 and entitled "WIRELESS ENERGY TRANSFER FOR REFRIGERATOR APPLICATION" and incorporated herein by reference in its entirety as if fully set forth herein.

[0068] A resonator may be defined as a resonant structure that can store energy in at least two different forms, and where the stored energy oscillates between the two forms.

The resonant structure will have a specific oscillation mode with a resonant (modal) frequency, f , and a resonant (modal) field. The angular resonant frequency, ω , may be defined as $\omega=2\pi f$, the resonant period, T , may be defined as $T=1/f=2\pi/\omega$, and the resonant wavelength, λ , may be defined as $\lambda=c/f$, where c is the speed of the associated field waves (light, for electromagnetic resonators). In the absence of loss mechanisms, coupling mechanisms or external energy supplying or draining mechanisms, the total amount of energy stored by the resonator, W , would stay fixed, but the form of the energy would oscillate between the two forms supported by the resonator, wherein one form would be maximum when the other is minimum and vice versa.

[0069] For example, a resonator may be constructed such that the two forms of stored energy are magnetic energy and electric energy. Further, the resonator may be constructed such that the electric energy stored by the electric field is primarily confined within the structure while the magnetic energy stored by the magnetic field is primarily in the region surrounding the resonator. In other words, the total electric and magnetic energies would be equal, but their localization would be different. Using such structures, energy exchange between at least two structures may be mediated by the resonant magnetic near-field of the at least two resonators. These types of resonators may be referred to as magnetic resonators.

[0070] An important parameter of resonators used in wireless power transmission systems is the Quality Factor, or Q-factor, or Q, of the resonator, which characterizes the energy decay and is inversely proportional to energy losses of the resonator. It may be defined as $Q=\omega*W/P$, where P is the time-averaged power lost at steady state. That is, a resonator with a high-Q has relatively low intrinsic losses and can store energy for a relatively long time. Since the resonator loses energy at its intrinsic decay rate, 2Γ , its Q, also referred to as its intrinsic Q, is given by $Q=\omega/2\Gamma$. The quality factor also represents the number of oscillation periods, T , it takes for the energy in the resonator to decay by a factor of Note that the quality factor or intrinsic quality factor or Q of the resonator is that due only to intrinsic loss mechanisms. The Q of a resonator connected to, or coupled to a power generator, g , or load, l , may be called the “loaded quality factor” or the “loaded Q”. The Q of a resonator in the presence of an extraneous object that is not intended to be part of the energy transfer system may be called the “perturbed quality factor” or the “perturbed Q”.

[0071] Resonators, coupled through any portion of their near-fields may interact and exchange energy. The efficiency of this energy transfer can be significantly enhanced if the resonators operate at substantially the same resonant frequency. By way of example, but not limitation, imagine a source resonator with Q_s and a device resonator with Q_d . High-Q wireless energy transfer systems may utilize resonators that are high-Q. The Q of each resonator may be high. The geometric mean of the resonator Q's, $\sqrt{Q_s Q_d}$ may also or instead be high.

[0072] The coupling factor, k , is a number between $0\leq|k|\leq 1$, and it may be independent (or nearly independent) of the resonant frequencies of the source and device resonators, when those are placed at sub-wavelength distances. Rather the coupling factor k may be determined mostly by the relative geometry and the distance between the source and device resonators where the physical decay-law of the field mediating their coupling is taken into account. The

coupling coefficient used in CMT, $k=k\sqrt{\omega_s\omega_d}/2$, may be a strong function of the resonant frequencies, as well as other properties of the resonator structures. In applications for wireless energy transfer utilizing the near-fields of the resonators, it is desirable to have the size of the resonator be much smaller than the resonant wavelength, so that power lost by radiation is reduced. In some embodiments, high-Q resonators are sub-wavelength structures. In some electromagnetic embodiments, high-Q resonator structures are designed to have resonant frequencies higher than 100 kHz. In other embodiments, the resonant frequencies may be less than 1 GHz.

[0073] In exemplary embodiments, the power radiated into the far-field by these sub wavelength resonators may be further reduced by lowering the resonant frequency of the resonators and the operating frequency of the system. In other embodiments, the far field radiation may be reduced by arranging for the far fields of two or more resonators to interfere destructively in the far field.

[0074] In a wireless energy transfer system a resonator may be used as a wireless energy source, a wireless energy capture device, a repeater or a combination thereof. In embodiments a resonator may alternate between transferring energy, receiving energy or relaying energy. In a wireless energy transfer system one or more magnetic resonators may be coupled to an energy source and be energized to produce an oscillating magnetic near-field. Other resonators that are within the oscillating magnetic near-fields may capture these fields and convert the energy into electrical energy that may be used to power or charge a load thereby enabling wireless transfer of useful energy.

[0075] The so-called “useful” energy in a useful energy exchange is the energy or power that must be delivered to a device in order to power or charge it at an acceptable rate. The transfer efficiency that corresponds to a useful energy exchange may be system or application-dependent. For example, high power vehicle charging applications that transfer kilowatts of power may need to be at least 80% efficient in order to supply useful amounts of power resulting in a useful energy exchange sufficient to recharge a vehicle battery without significantly heating up various components of the transfer system. In some consumer electronics applications, a useful energy exchange may include any energy transfer efficiencies greater than 10%, or any other amount acceptable to keep rechargeable batteries “topped off” and running for long periods of time. In implanted medical device applications, a useful energy exchange may be any exchange that does not harm the patient but that extends the life of a battery or wakes up a sensor or monitor or stimulator. In such applications, 100 mW of power or less may be useful. In distributed sensing applications, power transfer of microwatts may be useful, and transfer efficiencies may be well below 1%.

[0076] A useful energy exchange for wireless energy transfer in a powering or recharging application may be efficient, highly efficient, or efficient enough, as long as the wasted energy levels, heat dissipation, and associated field strengths are within tolerable limits and are balanced appropriately with related factors such as cost, weight, size, and the like.

[0077] The resonators may be referred to as source resonators, device resonators, first resonators, second resonators, repeater resonators, and the like. Implementations may include three (3) or more resonators. For example, a single

source resonator may transfer energy to multiple device resonators or multiple devices. Energy may be transferred from a first device to a second, and then from the second device to the third, and so forth. Multiple sources may transfer energy to a single device or to multiple devices connected to a single device resonator or to multiple devices connected to multiple device resonators. Resonators may serve alternately or simultaneously as sources, devices, and/or they may be used to relay power from a source in one location to a device in another location. Intermediate electromagnetic resonators may be used to extend the distance range of wireless energy transfer systems and/or to generate areas of concentrated magnetic near-fields. Multiple resonators may be daisy-chained together, exchanging energy over extended distances and with a wide range of sources and devices. For example, a source resonator may transfer power to a device resonator via several repeater resonators. Energy from a source may be transferred to a first repeater resonator, the first repeater resonator may transfer the power to a second repeater resonator and the second to a third and so on until the final repeater resonator transfers its energy to a device resonator. In this respect the range or distance of wireless energy transfer may be extended and/or tailored by adding repeater resonators. High power levels may be split between multiple sources, transferred to multiple devices and recombined at a distant location.

[0078] The resonators may be designed using coupled mode theory models, circuit models, electromagnetic field models, and the like. The resonators may be designed to have tunable characteristic sizes. The resonators may be designed to handle different power levels. In exemplary embodiments, high power resonators may require larger conductors and higher current or voltage rated components than lower power resonators.

[0079] FIG. 1 shows a diagram of exemplary configurations and arrangements of a wireless energy transfer system. A wireless energy transfer system may include at least one source resonator (R1) **104** (optionally **R6**, **112**) coupled to an energy source **102** and optionally a sensor and control unit **108**. The energy source may be a source of any type of energy capable of being converted into electrical energy that may be used to drive the source resonator **104**. The energy source may be a battery, a solar panel, the electrical mains, a wind or water turbine, an electromagnetic resonator, a generator, and the like. The electrical energy used to drive the magnetic resonator is converted into oscillating magnetic fields by the resonator. The oscillating magnetic fields may be captured by other resonators which may be device resonators (R2) **106**, (R3) **116** that are optionally coupled to an energy drain **110**. The oscillating fields may be optionally coupled to repeater resonators (R4, R5) that are configured to extend or tailor the wireless energy transfer region. Device resonators may capture the magnetic fields in the vicinity of source resonator(s), repeater resonators and other device resonators and convert them into electrical energy that may be used by an energy drain. The energy drain **110** may be an electrical, electronic, mechanical or chemical device and the like configured to receive electrical energy. Repeater resonators may capture magnetic fields in the vicinity of source, device and repeater resonator(s) and may pass the energy on to other resonators.

[0080] A wireless energy transfer system may comprise a single source resonator **104** coupled to an energy source **102** and a single device resonator **106** coupled to an energy drain

110. In embodiments a wireless energy transfer system may comprise multiple source resonators coupled to one or more energy sources and may comprise multiple device resonators coupled to one or more energy drains.

[0081] In embodiments the energy may be transferred directly between a source resonator **104** and a device resonator **106**. In other embodiments the energy may be transferred from one or more source resonators **104**, **112** to one or more device resonators **106**, **116** via any number of intermediate resonators which may be device resonators, source resonators, repeater resonators, and the like. Energy may be transferred via a network or arrangement of resonators **114** that may include subnetworks **118**, **120** arranged in any combination of topologies such as token ring, mesh, ad hoc, and the like.

[0082] In embodiments the wireless energy transfer system may comprise a centralized sensing and control system **108**. In embodiments parameters of the resonators, energy sources, energy drains, network topologies, operating parameters, etc. may be monitored and adjusted from a control processor to meet specific operating parameters of the system. A central control processor may adjust parameters of individual components of the system to optimize global energy transfer efficiency, to optimize the amount of power transferred, and the like. Other embodiments may be designed to have a substantially distributed sensing and control system. Sensing and control may be incorporated into each resonator or group of resonators, energy sources, energy drains, and the like and may be configured to adjust the parameters of the individual components in the group to maximize or minimize the power delivered, to maximize energy transfer efficiency in that group and the like.

[0083] In embodiments, components of the wireless energy transfer system may have wireless or wired data communication links to other components such as devices, sources, repeaters, power sources, resonators, and the like and may transmit or receive data that can be used to enable the distributed or centralized sensing and control. A wireless communication channel may be separate from the wireless energy transfer channel, or it may be the same. In one embodiment the resonators used for power exchange may also be used to exchange information. In some cases, information may be exchanged by modulating a component in a source or device circuit and sensing that change with port parameter or other monitoring equipment. Resonators may signal each other by tuning, changing, varying, dithering, and the like, the resonator parameters such as the impedance of the resonators which may affect the reflected impedance of other resonators in the system. The systems and methods described herein may enable the simultaneous transmission of power and communication signals between resonators in wireless power transmission systems, or it may enable the transmission of power and communication signals during different time periods or at different frequencies using the same magnetic fields that are used during the wireless energy transfer. In other embodiments wireless communication may be enabled with a separate wireless communication channel such as WiFi, Bluetooth, Infrared, NFC, and the like.

[0084] In embodiments, a wireless energy transfer system may include multiple resonators and overall system performance may be improved by control of various elements in the system. For example, devices with lower power requirements may tune their resonant frequency away from the

resonant frequency of a high-power source that supplies power to devices with higher power requirements. For another example, devices needing less power may adjust their rectifier circuits so that they draw less power from the source. In these ways, low and high power devices may safely operate or charge from a single high power source. In addition, multiple devices in a charging zone may find the power available to them regulated according to any of a variety of consumption control algorithms such as First-Come-First-Serve, Best Effort, Guaranteed Power, etc. The power consumption algorithms may be hierarchical in nature, giving priority to certain users or types of devices, or it may support any number of users by equally sharing the power that is available in the source. Power may be shared by any of the multiplexing techniques described in this disclosure.

[0085] In embodiments electromagnetic resonators may be realized or implemented using a combination of shapes, structures, and configurations. Electromagnetic resonators may include an inductive element, a distributed inductance, or a combination of inductances with a total inductance, L, and a capacitive element, a distributed capacitance, or a combination of capacitances, with a total capacitance, C. A minimal circuit model of an electromagnetic resonator comprising capacitance, inductance and resistance, is shown in FIG. 2F. The resonator may include an inductive element 238 and a capacitive element 240. Provided with initial energy, such as electric field energy stored in the capacitor 240, the system will oscillate as the capacitor discharges transferring energy into magnetic field energy stored in the inductor 238 which in turn transfers energy back into electric field energy stored in the capacitor 240. Intrinsic losses in these electromagnetic resonators include losses due to resistance in the inductive and capacitive elements and to radiation losses, and are represented by the resistor, R, 242 in FIG. 2F.

[0086] FIG. 2A shows a simplified drawing of an exemplary magnetic resonator structure. The magnetic resonator may include a loop of conductor acting as an inductive element 202 and a capacitive element 204 at the ends of the conductor loop. The inductor 202 and capacitor 204 of an electromagnetic resonator may be bulk circuit elements, or the inductance and capacitance may be distributed and may result from the way the conductors are formed, shaped, or positioned, in the structure.

[0087] For example, the inductor 202 may be realized by shaping a conductor to enclose a surface area, as shown in FIG. 2A. This type of resonator may be referred to as a capacitively-loaded loop inductor. Note that we may use the terms “loop” or “coil” to indicate generally a conducting structure (wire, tube, strip, etc.), enclosing a surface of any shape and dimension, with any number of turns. In FIG. 2A, the enclosed surface area is circular, but the surface may be any of a wide variety of other shapes and sizes and may be designed to achieve certain system performance specifications. In embodiments the inductance may be realized using inductor elements, distributed inductance, networks, arrays, series and parallel combinations of inductors and inductances, and the like. The inductance may be fixed or variable and may be used to vary impedance matching as well as resonant frequency operating conditions.

[0088] There are a variety of ways to realize the capacitance required to achieve the desired resonant frequency for a resonator structure. Capacitor plates 204 may be formed

and utilized as shown in FIG. 2A, or the capacitance may be distributed and be realized between adjacent windings of a multi-loop conductor. The capacitance may be realized using capacitor elements, distributed capacitance, networks, arrays, series and parallel combinations of capacitances, and the like. The capacitance may be fixed or variable and may be used to vary impedance matching as well as resonant frequency operating conditions.

[0089] The inductive elements used in magnetic resonators may contain more than one loop and may spiral inward or outward or up or down or in some combination of directions. In general, the magnetic resonators may have a variety of shapes, sizes and number of turns and they may be composed of a variety of conducting materials. The conductor 210, for example, may be a wire, a Litz wire, a ribbon, a pipe, a trace formed from conducting ink, paint, gels, and the like or from single or multiple traces printed on a circuit board. An exemplary embodiment of a trace pattern on a substrate 208 forming inductive loops is depicted in FIG. 2B.

[0090] In embodiments the inductive elements may be formed using magnetic materials of any size, shape thickness, and the like, and of materials with a wide range of permeability and loss values. These magnetic materials may be solid blocks, they may enclose hollow volumes, they may be formed from many smaller pieces of magnetic material tiled and or stacked together, and they may be integrated with conducting sheets or enclosures made from highly conducting materials. Conductors may be wrapped around the magnetic materials to generate the magnetic field. These conductors may be wrapped around one or more than one axis of the structure. Multiple conductors may be wrapped around the magnetic materials and combined in parallel, or in series, or via a switch to form customized near-field patterns and/or to orient the dipole moment of the structure. Examples of resonators comprising magnetic material are depicted in FIGS. 2C, 2D, 2E. In FIG. 2D the resonator comprises loops of conductor 224 wrapped around a core of magnetic material 222 creating a structure that has a magnetic dipole moment 228 that is parallel to the axis of the loops of the conductor 224. The resonator may comprise multiple loops of conductor 216, 212 wrapped in orthogonal directions around the magnetic material 214 forming a resonator with a magnetic dipole moment 218, 220 that may be oriented in more than one direction as depicted in FIG. 2C, depending on how the conductors are driven.

[0091] An electromagnetic resonator may have a characteristic, natural, or resonant frequency determined by its physical properties. This resonant frequency is the frequency at which the energy stored by the resonator oscillates between that stored by the electric field, W_E , ($W_E=q^2/2C$, where q is the charge on the capacitor, C) and that stored by the magnetic field, W_B , ($W_B=Li^2/2$, where i is the current through the inductor, L) of the resonator. The frequency at which this energy is exchanged may be called the characteristic frequency, the natural frequency, or the resonant frequency of the resonator, and is given by ω ,

$$\omega = 2\pi f = \sqrt{\frac{1}{LC}}.$$

The resonant frequency of the resonator may be changed by tuning the inductance, L , and/or the capacitance, C , of the resonator. In one embodiment system parameters are dynamically adjustable or tunable to achieve as close as possible to optimal operating conditions. However, based on the discussion above, efficient enough energy exchange may be realized even if some system parameters are not variable or components are not capable of dynamic adjustment.

[0092] In embodiments a resonator may comprise an inductive element coupled to more than one capacitor arranged in a network of capacitors and circuit elements. In embodiments the coupled network of capacitors and circuit elements may be used to define more than one resonant frequency of the resonator. In embodiments a resonator may be resonant, or partially resonant, at more than one frequency.

[0093] In embodiments, a wireless power source may comprise of at least one resonator coil coupled to a power supply, which may be a switching amplifier, such as a class-D amplifier or a class-E amplifier or a combination thereof. In this case, the resonator coil is effectively a power load to the power supply. In embodiments, a wireless power device may comprise of at least one resonator coil coupled to a power load, which may be a switching rectifier, such as a class-D rectifier or a class-E rectifier or a combination thereof. In this case, the resonator coil is effectively a power supply for the power load, and the impedance of the load directly relates also to the work-drainage rate of the load from the resonator coil. The efficiency of power transmission between a power supply and a power load may be impacted by how closely matched the output impedance of the power source is to the input impedance of the load. Power may be delivered to the load at a maximum possible efficiency, when the input impedance of the load is equal to the complex conjugate of the internal impedance of the power supply. Designing the power supply or power load impedance to obtain a maximum power transmission efficiency is often called “impedance matching”, and may also referred to as optimizing the ratio of useful-to-lost powers in the system. Impedance matching may be performed by adding networks or sets of elements such as capacitors, inductors, transformers, switches, resistors, and the like, to form impedance matching networks between a power supply and a power load. In embodiments, mechanical adjustments and changes in element positioning may be used to achieve impedance matching. For varying loads, the impedance matching network may include variable components that are dynamically adjusted to ensure that the impedance at the power supply terminals looking towards the load and the characteristic impedance of the power supply remain substantially complex conjugates of each other, even in dynamic environments and operating scenarios.

[0094] In embodiments, impedance matching may be accomplished by tuning the duty cycle, and/or the phase, and/or the frequency of the driving signal of the power supply or by tuning a physical component within the power supply, such as a capacitor. Such a tuning mechanism may be advantageous because it may allow impedance matching between a power supply and a load without the use of a tunable impedance matching network, or with a simplified tunable impedance matching network, such as one that has fewer tunable components for example. In embodiments, tuning the duty cycle, and/or frequency, and/or phase of the driving signal to a power supply may yield a dynamic

impedance matching system with an extended tuning range or precision, with higher power, voltage and/or current capabilities, with faster electronic control, with fewer external components, and the like.

[0095] In some wireless energy transfer systems the parameters of the resonator such as the inductance may be affected by environmental conditions such as surrounding objects, temperature, orientation, number and position of other resonators and the like. Changes in operating parameters of the resonators may change certain system parameters, such as the efficiency of transferred power in the wireless energy transfer. For example, high-conductivity materials located near a resonator may shift the resonant frequency of a resonator and detune it from other resonant objects. In some embodiments, a resonator feedback mechanism is employed that corrects its frequency by changing a reactive element (e.g., an inductive element or capacitive element). In order to achieve acceptable matching conditions, at least some of the system parameters may need to be dynamically adjustable or tunable. All the system parameters may be dynamically adjustable or tunable to achieve approximately the optimal operating conditions. However, efficient enough energy exchange may be realized even if all or some system parameters are not variable. In some examples, at least some of the devices may not be dynamically adjusted. In some examples, at least some of the sources may not be dynamically adjusted. In some examples, at least some of the intermediate resonators may not be dynamically adjusted. In some examples, none of the system parameters may be dynamically adjusted.

[0096] In some embodiments changes in parameters of components may be mitigated by selecting components with characteristics that change in a complimentary or opposite way or direction when subjected to differences in operating environment or operating point. In embodiments, a system may be designed with components, such as capacitors, that have an opposite dependence or parameter fluctuation due to temperature, power levels, frequency, and the like. In some embodiments, the component values as a function of temperature may be stored in a look-up table in a system microcontroller and the reading from a temperature sensor may be used in the system control feedback loop to adjust other parameters to compensate for the temperature induced component value changes.

[0097] In some embodiments the changes in parameter values of components may be compensated with active tuning circuits comprising tunable components. Circuits that monitor the operating environment and operating point of components and system may be integrated in the design. The monitoring circuits may provide the signals necessary to actively compensate for changes in parameters of components. For example, a temperature reading may be used to calculate expected changes in, or to indicate previously measured values of, capacitance of the system allowing compensation by switching in other capacitors or tuning capacitors to maintain the desired capacitance over a range of temperatures. In embodiments, the RF amplifier switching waveforms may be adjusted to compensate for component value or load changes in the system. In some embodiments the changes in parameters of components may be compensated with active cooling, heating, active environment conditioning, and the like.

[0098] The parameter measurement circuitry may measure or monitor certain power, voltage, and current, signals in the

system, and processors or control circuits may adjust certain settings or operating parameters based on those measurements. In addition the magnitude and phase of voltage and current signals, and the magnitude of the power signals, throughout the system may be accessed to measure or monitor the system performance. The measured signals referred to throughout this disclosure may be any combination of port parameter signals, as well as voltage signals, current signals, power signals, temperatures signals and the like. These parameters may be measured using analog or digital techniques, they may be sampled and processed, and they may be digitized or converted using a number of known analog and digital processing techniques. In embodiments, preset values of certain measured quantities are loaded in a system controller or memory location and used in various feedback and control loops. In embodiments, any combination of measured, monitored, and/or preset signals may be used in feedback circuits or systems to control the operation of the resonators and/or the system.

[0099] Adjustment algorithms may be used to adjust the frequency, Q, and/or impedance of the magnetic resonators. The algorithms may take as inputs reference signals related to the degree of deviation from a desired operating point for the system and may output correction or control signals related to that deviation that control variable or tunable elements of the system to bring the system back towards the desired operating point or points. The reference signals for the magnetic resonators may be acquired while the resonators are exchanging power in a wireless power transmission system, or they may be switched out of the circuit during system operation. Corrections to the system may be applied or performed continuously, periodically, upon a threshold crossing, digitally, using analog methods, and the like.

[0100] In embodiments, lossy extraneous materials and objects may introduce potential reductions in efficiencies by absorbing the magnetic and/or electric energy of the resonators of the wireless power transmission system. Those impacts may be mitigated in various embodiments by positioning resonators to minimize the effects of the lossy extraneous materials and objects and by placing structural field shaping elements (e.g., conductive structures, plates and sheets, magnetic material structures, plates and sheets, and combinations thereof) to minimize their effect.

[0101] One way to reduce the impact of lossy materials on a resonator is to use high-conductivity materials, magnetic materials, or combinations thereof to shape the resonator fields such that they avoid the lossy objects. In an exemplary embodiment, a layered structure of high-conductivity material and magnetic material may tailor, shape, direct, reorient, etc. the resonator's electromagnetic fields so that they avoid lossy objects in their vicinity by deflecting the fields. FIG. 2D shows a top view of a resonator with a sheet of conductor 226 below the magnetic material that may be used to tailor the fields of the resonator so that they avoid lossy objects that may be below the sheet of conductor 226. The layer or sheet of good 226 conductor may comprise any high conductivity materials such as copper, silver, aluminum, as may be most appropriate for a given application. In certain embodiments, the layer or sheet of good conductor is thicker than the skin depth of the conductor at the resonator operating frequency. The conductor sheet may be preferably larger than the size of the resonator, extending beyond the physical extent of the resonator.

[0102] In environments and systems where the amount of power being transmitted could present a safety hazard to a person or animal that may intrude into the active field volume, safety measures may be included in the system. In embodiments where power levels require particularized safety measures, the packaging, structure, materials, and the like of the resonators may be designed to provide a spacing or "keep away" zone from the conducting loops in the magnetic resonator. To provide further protection, high-Q resonators and power and control circuitry may be located in enclosures that confine high voltages or currents to within the enclosure, that protect the resonators and electrical components from weather, moisture, sand, dust, and other external elements, as well as from impacts, vibrations, scrapes, explosions, and other types of mechanical shock. Such enclosures call for attention to various factors such as thermal dissipation to maintain an acceptable operating temperature range for the electrical components and the resonator. In embodiments, enclosure may be constructed of non-lossy materials such as composites, plastics, wood, concrete, and the like and may be used to provide a minimum distance from lossy objects to the resonator components. A minimum separation distance from lossy objects or environments which may include metal objects, salt water, oil and the like, may improve the efficiency of wireless energy transfer. In embodiments, a "keep away" zone may be used to increase the perturbed Q of a resonator or system of resonators. In embodiments a minimum separation distance may provide for a more reliable or more constant operating parameters of the resonators.

[0103] In embodiments, resonators and their respective sensor and control circuitry may have various levels of integration with other electronic and control systems and subsystems. In some embodiments the power and control circuitry and the device resonators are completely separate modules or enclosures with minimal integration to existing systems, providing a power output and a control and diagnostics interface. In some embodiments a device is configured to house a resonator and circuit assembly in a cavity inside the enclosure, or integrated into the housing or enclosure of the device.

[0104] Example Resonator Circuitry

[0105] FIGS. 3 and 4 show high level block diagrams depicting power generation, monitoring, and control components for exemplary sources of a wireless energy transfer system. FIG. 3 is a block diagram of a source comprising a half-bridge switching power amplifier and some of the associated measurement, tuning, and control circuitry. FIG. 4 is a block diagram of a source comprising a full-bridge switching amplifier and some of the associated measurement, tuning, and control circuitry.

[0106] The half bridge system topology depicted in FIG. 3 may comprise a processing unit that executes a control algorithm 328. The processing unit executing a control algorithm 328 may be a microcontroller, an application specific circuit, a field programmable gate array, a processor, a digital signal processor, and the like. The processing unit may be a single device or it may be a network of devices. The control algorithm may run on any portion of the processing unit. The algorithm may be customized for certain applications and may comprise a combination of analog and digital circuits and signals. The master algorithm

may measure and adjust voltage signals and levels, current signals and levels, signal phases, digital count settings, and the like.

[0107] The system may comprise an optional source/device and/or source/other resonator communication controller 332 coupled to wireless communication circuitry 312. The optional source/device and/or source/other resonator communication controller 332 may be part of the same processing unit that executes the master control algorithm, it may be a part or a circuit within a microcontroller 302, it may be external to the wireless power transmission modules, it may be substantially similar to communication controllers used in wire powered or battery powered applications but adapted to include some new or different functionality to enhance or support wireless power transmission.

[0108] The system may comprise a PWM generator 306 coupled to at least two transistor gate drivers 334 and may be controlled by the control algorithm. The two transistor gate drivers 334 may be coupled directly or via gate drive transformers to two power transistors 336 that drive the source resonator coil 344 through impedance matching network components 342. The power transistors 336 may be coupled and powered with an adjustable DC supply 304 and the adjustable DC supply 304 may be controlled by a variable bus voltage, V_{bus} . The V_{bus} controller may be controlled by the control algorithm 328 and may be part of, or integrated into, a microcontroller 302 or other integrated circuits. The V_{bus} controller 326 may control the voltage output of an adjustable DC supply 304 which may be used to control power output of the amplifier and power delivered to the resonator coil 344.

[0109] The system may comprise sensing and measurement circuitry including signal filtering and buffering circuits 318, 320 that may shape, modify, filter, process, buffer, and the like, signals prior to their input to processors and/or converters such as analog to digital converters (ADC) 314, 316, for example. The processors and converters such as ADCs 314, 316 may be integrated into a microcontroller 302 or may be separate circuits that may be coupled to a processing core 330. Based on measured signals, the control algorithm 328 may generate, limit, initiate, extinguish, control, adjust, or modify the operation of any of the PWM generator 306, the communication controller 332, the V_{bus} control 326, the source impedance matching controller 338, the filter/buffering elements, 318, 320, the converters, 314, 316, the resonator coil 344, and may be part of, or integrated into, a microcontroller 302 or a separate circuit. The impedance matching networks 342 and resonator coils 344 may include electrically controllable, variable, or tunable components such as capacitors, switches, inductors, and the like, as described herein, and these components may have their component values or operating points adjusted according to signals received from the source impedance matching controller 338. Components may be tuned to adjust the operation and characteristics of the resonator including the power delivered to and by the resonator, the resonant frequency of the resonator, the impedance of the resonator, the Q of the resonator, and any other coupled systems, and the like. The resonator may be any type or structure resonator described herein including a capacitively loaded loop resonator, a planar resonator comprising a magnetic material or any combination thereof.

[0110] The full bridge system topology depicted in FIG. 4 may comprise a processing unit that executes a master

control algorithm 328. The processing unit executing the control algorithm 328 may be a microcontroller, an application specific circuit, a field programmable gate array, a processor, a digital signal processor, and the like. The system may comprise a source/device and/or source/other resonator communication controller 332 coupled to wireless communication circuitry 312. The source/device and/or source/other resonator communication controller 332 may be part of the same processing unit that executes that master control algorithm, it may be a part or a circuit within a microcontroller 302, it may be external to the wireless power transmission modules, it may be substantially similar to communication controllers used in wire powered or battery powered applications but adapted to include some new or different functionality to enhance or support wireless power transmission.

[0111] The system may comprise a PWM generator 410 with at least two outputs coupled to at least four transistor gate drivers 334 that may be controlled by signals generated in a master control algorithm. The four transistor gate drivers 334 may be coupled to four power transistors 336 directly or via gate drive transformers that may drive the source resonator coil 344 through impedance matching networks 342. The power transistors 336 may be coupled and powered with an adjustable DC supply 304 and the adjustable DC supply 304 may be controlled by a V_{bus} controller 326 which may be controlled by a master control algorithm. The V_{bus} controller 326 may control the voltage output of the adjustable DC supply 304 which may be used to control power output of the amplifier and power delivered to the resonator coil 344.

[0112] The system may comprise sensing and measurement circuitry including signal filtering and buffering circuits 318, 320 and differential/single ended conversion circuitry 402, 404 that may shape, modify, filter, process, buffer, and the like, signals prior to being input to processors and/or converters such as analog to digital converters (ADC) 314, 316. The processors and/or converters such as ADC 314, 316 may be integrated into a microcontroller 302 or may be separate circuits that may be coupled to a processing core 330. Based on measured signals, the master control algorithm may generate, limit, initiate, extinguish, control, adjust, or modify the operation of any of the PWM generator 410, the communication controller 332, the V_{bus} controller 326, the source impedance matching controller 338, the filter/buffering elements, 318, 320, differential/single ended conversion circuitry 402, 404, the converters, 314, 316, the resonator coil 344, and may be part of or integrated into a microcontroller 302 or a separate circuit.

[0113] Impedance matching networks 342 and resonator coils 344 may comprise electrically controllable, variable, or tunable components such as capacitors, switches, inductors, and the like, as described herein, and these components may have their component values or operating points adjusted according to signals received from the source impedance matching controller 338. Components may be tuned to enable tuning of the operation and characteristics of the resonator including the power delivered to and by the resonator, the resonant frequency of the resonator, the impedance of the resonator, the Q of the resonator, and any other coupled systems, and the like. The resonator may be any type or structure resonator described herein including a capacitively loaded loop resonator, a planar resonator comprising a magnetic material or any combination thereof.

[0114] Impedance matching networks may comprise fixed value components such as capacitors, inductors, and networks of components as described herein. Parts of the impedance matching networks, A, B and C, may comprise inductors, capacitors, transformers, and series and parallel combinations of such components, as described herein. In some embodiments, parts of the impedance matching networks A, B, and C, may be empty (short-circuited). In some embodiments, part B comprises a series combination of an inductor and a capacitor, and part C is empty.

[0115] The full bridge topology may allow operation at higher output power levels using the same DC bus voltage as an equivalent half bridge amplifier. The half bridge exemplary topology of FIG. 3 may provide a single-ended drive signal, while the exemplary full bridge topology of FIG. 4 may provide a differential drive to the source resonator 308. The impedance matching topologies and components and the resonator structure may be different for the two systems, as discussed herein.

[0116] The exemplary systems depicted in FIGS. 3 and 4 may further include fault detection circuitry 340 that may be used to trigger the shutdown of the microcontroller in the source amplifier or to change or interrupt the operation of the amplifier. This protection circuitry may comprise a high speed comparator or comparators to monitor the amplifier return current, the amplifier bus voltage (Vbus) from the DC supply 304, the voltage across the source resonator 308 and/or the optional tuning board, or any other voltage or current signals that may cause damage to components in the system or may yield undesirable operating conditions. Preferred embodiments may depend on the potentially undesirable operating modes associated with different applications. In some embodiments, protection circuitry may not be implemented or circuits may not be populated. In some embodiments, system and component protection may be implemented as part of a master control algorithm and other system monitoring and control circuits. In embodiments, dedicated fault circuitry 340 may include an output (not shown) coupled to a master control algorithm 328 that may trigger a system shutdown, a reduction of the output power (e.g. reduction of Vbus), a change to the PWM generator, a change in the operating frequency, a change to a tuning element, or any other reasonable action that may be implemented by the control algorithm 328 to adjust the operating point mode, improve system performance, and/or provide protection.

[0117] As described herein, sources in wireless power transfer systems may use a measurement of the input impedance of the impedance matching network 342 driving source resonator coil 344 as an error or control signal for a system control loop that may be part of the master control algorithm. In exemplary embodiments, variations in any combination of three parameters may be used to tune the wireless power source to compensate for changes in environmental conditions, for changes in coupling, for changes in device power demand, for changes in module, circuit, component or subsystem performance, for an increase or decrease in the number or sources, devices, or repeaters in the system, for user initiated changes, and the like. In exemplary embodiments, changes to the amplifier duty cycle, to the component values of the variable electrical components such as variable capacitors and inductors, and to the DC bus voltage may be used to change the operating point or operating range of the wireless source and improve some system operating value.

The specifics of the control algorithms employed for different applications may vary depending on the desired system performance and behavior.

[0118] Impedance measurement circuitry such as described herein, and shown in FIGS. 3 and 4, may be implemented using two-channel simultaneous sampling ADCs and these ADCs may be integrated into a microcontroller chip or may be part of a separate circuit. Simultaneously sampling of the voltage and current signals at the input to a source resonator's impedance matching network and/or the source resonator, may yield the phase and magnitude information of the current and voltage signals and may be processed using known signal processing techniques to yield complex impedance parameters. In some embodiments, monitoring only the voltage signals or only the current signals may be sufficient.

[0119] The impedance measurements described herein may use direct sampling methods which may be relatively simpler than some other known sampling methods. In embodiments, measured voltage and current signals may be conditioned, filtered and scaled by filtering/buffering circuitry before being input to ADCs. In embodiments, the filter/buffering circuitry may be adjustable to work at a variety of signal levels and frequencies, and circuit parameters such as filter shapes and widths may be adjusted manually, electronically, automatically, in response to a control signal, by the master control algorithm, and the like. Exemplary embodiments of filter/buffering circuits are shown in FIGS. 3, 4, and 5.

[0120] FIG. 5 shows more detailed views of exemplary circuit components that may be used in filter/buffering circuitry. In embodiments, and depending on the types of ADCs used in the system designs, single-ended amplifier topologies may reduce the complexity of the analog signal measurement paths used to characterize system, subsystem, module and/or component performance by eliminating the need for hardware to convert from differential to single-ended signal formats. In other implementations, differential signal formats may be preferable. The implementations shown in FIG. 5 are exemplary, and should not be construed to be the only possible way to implement the functionality described herein. Rather it should be understood that the analog signal path may employ components with different input requirements and hence may have different signal path architectures.

[0121] In both the single ended and differential amplifier topologies, the input current to the impedance matching networks 342 driving the resonator coils 344 may be obtained by measuring the voltage across a capacitor 324, or via a current sensor of some type. For the exemplary single-ended amplifier topology in FIG. 3, the current may be sensed on the ground return path from the impedance matching network 342. For the exemplary differential power amplifier depicted in FIG. 4, the input current to the impedance matching networks 342 driving the resonator coils 344 may be measured using a differential amplifier across the terminals of a capacitor 324 or via a current sensor of some type. In the differential topology of FIG. 4, the capacitor 324 may be duplicated at the negative output terminal of the source power amplifier.

[0122] In both topologies, after single ended signals representing the input voltage and current to the source resonator and impedance matching network are obtained, the signals may be filtered 502 to obtain the desired portions of

the signal waveforms. In embodiments, the signals may be filtered to obtain the fundamental component of the signals. In embodiments, the type of filtering performed, such as low pass, bandpass, notch, and the like, as well as the filter topology used, such as elliptical, Chebyshev, Butterworth, and the like, may depend on the specific requirements of the system. In some embodiments, no filtering will be required.

[0123] The voltage and current signals may be amplified by an optional amplifier **504**. The gain of the optional amplifier **504** may be fixed or variable. The gain of the amplifier may be controlled manually, electronically, automatically, in response to a control signal, and the like. The gain of the amplifier may be adjusted in a feedback loop, in response to a control algorithm, by the master control algorithm, and the like. In embodiments, required performance specifications for the amplifier may depend on signal strength and desired measurement accuracy, and may be different for different application scenarios and control algorithms.

[0124] The measured analog signals may have a DC offset added to them, **506**, which may be required to bring the signals into the input voltage range of the ADC which for some systems may be 0 to 3.3V. In some systems this stage may not be required, depending on the specifications of the particular ADC used.

[0125] As described above, the efficiency of power transmission between a power generator and a power load may be impacted by how closely matched the output impedance of the generator is to the input impedance of the load. In an exemplary system as shown in FIG. 6A, power may be delivered to the load at a maximum possible efficiency, when the input impedance of the load **604** is equal to the complex conjugate of the internal impedance of the power generator or the power amplifier **602**. Designing the generator or load impedance to obtain a high and/or maximum power transmission efficiency may be called “impedance matching”. Impedance matching may be performed by inserting appropriate networks or sets of elements such as capacitors, resistors, inductors, transformers, switches and the like, to form an impedance matching network **606**, between a power generator **602** and a power load **604** as shown in FIG. 6B. In other embodiments, mechanical adjustments and changes in element positioning may be used to achieve impedance matching. As described above for varying loads, the impedance matching network **606** may include variable components that are dynamically adjusted to ensure that the impedance at the generator terminals looking towards the load and the characteristic impedance of the generator remain substantially complex conjugates of each other, even in dynamic environments and operating scenarios. In embodiments, dynamic impedance matching may be accomplished by tuning the duty cycle, and/or the phase, and/or the frequency of the driving signal of the power generator or by tuning a physical component within the power generator, such as a capacitor, as depicted in FIG. 6C. Such a tuning mechanism may be advantageous because it may allow impedance matching between a power generator **608** and a load without the use of a tunable impedance matching network, or with a simplified tunable impedance matching network **606**, such as one that has fewer tunable components for example. In embodiments, tuning the duty cycle, and/or frequency, and/or phase of the driving signal to a power generator may yield a dynamic impedance matching system with an extended tuning range or precision, with higher

power, voltage and/or current capabilities, with faster electronic control, with fewer external components, and the like. The impedance matching methods, architectures, algorithms, protocols, circuits, measurements, controls, and the like, described below, may be useful in systems where power generators drive high-Q magnetic resonators and in high-Q wireless power transmission systems as described herein. In wireless power transfer systems a power generator may be a power amplifier driving a resonator, sometimes referred to as a source resonator, which may be a load to the power amplifier. In wireless power applications, it may be preferable to control the impedance matching between a power amplifier and a resonator load to control the efficiency of the power delivery from the power amplifier to the resonator. The impedance matching may be accomplished, or accomplished in part, by tuning or adjusting the duty cycle, and/or the phase, and/or the frequency of the driving signal of the power amplifier that drives the resonator.

[0126] Efficiency of Switching Amplifiers

[0127] Switching amplifiers, such as class D, E, F amplifiers, and the like or any combinations thereof, deliver power to a load at a maximum efficiency when almost no power is dissipated on the switching elements of the amplifier. This operating condition may be accomplished by designing the system so that the switching operations which are most critical (namely those that are most likely to lead to switching losses) are done when either or both of the voltage across the switching element and the current through the switching element are nearly zero. These conditions may be referred to as Zero Voltage Switching (ZVS) and Zero Current Switching (ZCS) conditions respectively. When an amplifier operates at ZVS and/or ZCS either the voltage across the switching element or the current through the switching element is zero and thus no power can be dissipated in the switch. Since a switching amplifier may convert DC (or very low frequency AC) power to AC power at a specific frequency or range of frequencies, a filter may be introduced before the load to prevent unwanted harmonics that may be generated by the switching process from reaching the load and being dissipated there. In embodiments, a switching amplifier may be designed to operate at maximum efficiency of power conversion, when connected to a resonant load, with a quality factor (say $Q > 5$), and of a specific impedance $Z_o^* = R_o + jX_o$, which leads to simultaneous ZVS and ZCS. We define $Z_o = R_o - jX_o$ as the characteristic impedance of the amplifier, so that achieving maximum power transmission efficiency is equivalent to impedance matching the resonant load to the characteristic impedance of the amplifier.

[0128] In a switching amplifier, the switching frequency of the switching elements, f_{switch} , wherein $f_{switch} = \omega / 2\pi$ and the duty cycle, dc, of the ON switch-state duration of the switching elements may be the same for all switching elements of the amplifier. In this specification, we will use the term “class D” to denote both class D and class DE amplifiers, that is, switching amplifiers with $dc \leq 50\%$.

[0129] The value of the characteristic impedance of the amplifier may depend on the operating frequency, the amplifier topology, and the switching sequence of the switching elements. In some embodiments, the switching amplifier may be a half-bridge topology and, in some embodiments, a full-bridge topology. In some embodiments, the switching amplifier may be class D and, in some embodiments, class E. In any of the above embodiments, assuming the elements

of the bridge are symmetric, the characteristic impedance of the switching amplifier has the form

$$R_o = F_R(dc)/\omega C_a, X_o = F_X(dc)/\omega C_a, \quad (1)$$

where dc is the duty cycle of ON switch-state of the switching elements, the functions $F_R(dc)$ and $F_X(dc)$ are plotted in FIG. 7 (both for class D and E), ω is the frequency at which the switching elements are switched, and $C_a = n_a C_{switch}$ where C_{switch} is the capacitance across each switch, including both the transistor output capacitance and also possible external capacitors placed in parallel with the switch, while $n_a = 1$ for a full bridge and $n_a = 2$ for a half bridge. For class D, one can also write the analytical expressions

$$F_R(dc) = \sin^2 u/\pi, F_X(dc) = (u - \sin u \cos u)/\pi, \quad (2)$$

where $u = \pi(1 - 2dc)$, indicating that the characteristic impedance level of a class D amplifier decreases as the duty cycle, dc , increases towards 50%. For a class D amplifier operation with $dc = 50\%$, achieving ZVS and ZCS is possible only when the switching elements have practically no output capacitance ($C_a = 0$) and the load is exactly on resonance ($X_o = 0$), while R_o can be arbitrary.

[0130] Impedance Matching Networks

[0131] In applications, the driven load may have impedance that is very different from the characteristic impedance of the external driving circuit, to which it is connected. Furthermore, the driven load may not be a resonant network. An Impedance Matching Network (IMN) is a circuit network that may be connected before a load as in FIG. 6B, in order to regulate the impedance that is seen at the input of the network consisting of the IMN circuit and the load. An IMN circuit may typically achieve this regulation by creating a resonance close to the driving frequency. Since such an IMN circuit accomplishes all conditions needed to maximize the power transmission efficiency from the generator to the load (resonance and impedance matching-ZVS and ZCS for a switching amplifier), in embodiments, an IMN circuit may be used between the driving circuit and the load.

[0132] For an arrangement shown in FIG. 6B, let the input impedance of the network consisting of the Impedance Matching Network (IMN) circuit and the load (denoted together from now on as IMN+load) be $Z_l = R_l(\omega) + jX_l(\omega)$. The impedance matching conditions of this network to the external circuit with characteristic impedance $Z_o = R_o - jX_o$ are then $R_l(\omega) = R_o$, $X_l(\omega) = X_o$.

[0133] Methods for Tunable Impedance Matching of a Variable Load

[0134] In embodiments where the load may be variable, impedance matching between the load and the external driving circuit, such as a linear or switching power amplifier, may be achieved by using adjustable/tunable components in the IMN circuit that may be adjusted to match the varying load to the fixed characteristic impedance Z_o of the external circuit (FIG. 6B). To match both the real and imaginary parts of the impedance two tunable/variable elements in the IMN circuit may be needed.

[0135] In embodiments, the load may be inductive (such as a resonator coil) with impedance $R + j\omega L$, so the two tunable elements in the IMN circuit may be two tunable capacitance networks or one tunable capacitance network and one tunable inductance network or one tunable capacitance network and one tunable mutual inductance network.

[0136] In embodiments where the load may be variable, the impedance matching between the load and the driving

circuit, such as a linear or switching power amplifier, may be achieved by using adjustable/tunable components or parameters in the amplifier circuit that may be adjusted to match the characteristic impedance Z_o of the amplifier to the varying (due to load variations) input impedance of the network consisting of the IMN circuit and the load (IMN+load), where the IMN circuit may also be tunable (FIG. 6C). To match both the real and imaginary parts of the impedance, a total of two tunable/variable elements or parameters in the amplifier and the IMN circuit may be needed. The disclosed impedance matching method can reduce the required number of tunable/variable elements in the IMN circuit or even completely eliminate the requirement for tunable/variable elements in the IMN circuit. In some examples, one tunable element in the power amplifier and one tunable element in the IMN circuit may be used. In some examples, two tunable elements in the power amplifier and no tunable element in the IMN circuit may be used.

[0137] In embodiments, the tunable elements or parameters in the power amplifier may be the frequency, amplitude, phase, waveform, duty cycle and the like of the drive signals applied to transistors, switches, diodes and the like.

[0138] In embodiments, the power amplifier with tunable characteristic impedance may be a tunable switching amplifier of class D, E, F or any combinations thereof. Combining Equations (1) and (2), the impedance matching conditions for this network are

$$R_l(\omega) = F_R(dc)/\omega C_a, X_l(\omega) = F_X(dc)/\omega C_a \quad (3)$$

[0139] In some examples of a tunable switching amplifier, one tunable element may be the capacitance C_a , which may be tuned by tuning the external capacitors placed in parallel with the switching elements.

[0140] In some examples of a tunable switching amplifier, one tunable element may be the duty cycle dc of the ON switch-state of the switching elements of the amplifier. Adjusting the duty cycle, dc , via Pulse Width Modulation (PWM) has been used in switching amplifiers to achieve output power control. In this specification, we disclose that PWM may also be used to achieve impedance matching, namely to satisfy Eqs.(3), and thus maximize the amplifier efficiency.

[0141] In some examples of a tunable switching amplifier one tunable element may be the switching frequency, which is also the driving frequency of the IMN+load network and may be designed to be substantially close to the resonant frequency of the IMN+load network. Tuning the switching frequency may change the characteristic impedance of the amplifier and the impedance of the IMN+load network. The switching frequency of the amplifier may be tuned appropriately together with one more tunable parameters, so that Eqs.(3) are satisfied.

[0142] A benefit of tuning the duty cycle and/or the driving frequency of the amplifier for dynamic impedance matching is that these parameters can be tuned electronically, quickly, and over a broad range. In contrast, for example, a tunable capacitor that can sustain a large voltage and has a large enough tunable range and quality factor may be expensive, slow or unavailable for with the necessary component specifications

[0143] Examples of Methods for Tunable Impedance Matching of a Variable Load

[0144] A simplified circuit diagram showing the circuit level structure of a class D power amplifier 802, impedance

matching network **804** and an inductive load **806** is shown in FIG. **8**. The diagram shows the basic components of the system with the switching amplifier **804** comprising a power source **810**, switching elements **808**, and capacitors. The impedance matching network **804** comprising inductors and capacitors, and the load **806** modeled as an inductor and a resistor.

[0145] An exemplary embodiment of this inventive tuning scheme comprises a half-bridge class-D amplifier operating at switching frequency f and driving a low-loss inductive element $R+j\omega L$ via an IMN, as shown in FIG. **8**.

[0146] In some embodiments L' may be tunable. L' may be tuned by a variable tapping point on the inductor or by connecting a tunable capacitor in series or in parallel to the inductor. In some embodiments C_a may be tunable. For the half bridge topology, C_a may be tuned by varying either one or both capacitors C_{switch} , as only the parallel sum of these capacitors matters for the amplifier operation. For the full bridge topology, C_a may be tuned by varying either one, two, three or all capacitors C_{switch} , as only their combination (series sum of the two parallel sums associated with the two halves of the bridge) matters for the amplifier operation.

[0147] In some embodiments of tunable impedance matching, two of the components of the IMN may be tunable. In some embodiments, L' and C_2 may be tuned. Then, FIG. **9** shows the values of the two tunable components needed to achieve impedance matching as functions of the varying R and L of the inductive element, and the associated variation of the output power (at given DC bus voltage) of the amplifier, for $f=250$ kHz, $dc=40\%$, $C_a=640$ pF and $C_1=10$ nF. Since the IMN always adjusts to the fixed characteristic impedance of the amplifier, the output power is always constant as the inductive element is varying.

[0148] In some embodiments of tunable impedance matching, elements in the switching amplifier may also be tunable. In some embodiments the capacitance C_a along with the IMN capacitor C_2 may be tuned. Then, FIG. **10** shows the values of the two tunable components needed to achieve impedance matching as functions of the varying R and L of the inductive element, and the associated variation of the output power (at given DC bus voltage) of the amplifier for $f=250$ kHz, $dc=40\%$, $C_1=10$ nF and $\omega L'=1000\Omega$. It can be inferred from FIG. **10** that C_2 needs to be tuned mainly in response to variations in L and that the output power decreases as R increases.

[0149] In some embodiments of tunable impedance matching, the duty cycle dc along with the IMN capacitor C_2 may be tuned. Then, FIG. **11** shows the values of the two tunable parameters needed to achieve impedance matching as functions of the varying R and L of the inductive element, and the associated variation of the output power (at given DC bus voltage) of the amplifier for $f=250$ kHz, $C_a=640$ pF, $C_1=10$ nF and $\omega L'=1000\Omega$. It can be inferred from FIG. **11** that C_2 needs to be tuned mainly in response to variations in L and that the output power decreases as R increases.

[0150] In some embodiments of tunable impedance matching, the capacitance C_a along with the IMN inductor L' may be tuned. Then, FIG. **11A** shows the values of the two tunable components needed to achieve impedance matching as functions of the varying R of the inductive element, and the associated variation of the output power (at given DC bus voltage) of the amplifier for $f=250$ kHz, $dc=40\%$, $C_1=10$ nF and $C_2=7.5$ nF. It can be inferred from FIG. **11A** that the output power decreases as R increases.

[0151] In some embodiments of tunable impedance matching, the duty cycle dc along with the IMN inductor L' may be tuned. Then, FIG. **11B** shows the values of the two tunable parameters needed to achieve impedance matching as functions of the varying R of the inductive element, and the associated variation of the output power (at given DC bus voltage) of the amplifier for $f=250$ kHz, $C_a=640$ pF, $C_1=10$ nF and $C_2=7.5$ nF as functions of the varying R of the inductive element. It can be inferred from FIG. **11B** that the output power decreases as R increases.

[0152] In some embodiments of tunable impedance matching, only elements in the switching amplifier may be tunable with no tunable elements in the IMN. In some embodiments the duty cycle dc along with the capacitance C_a may be tuned. Then, FIG. **11C**, shows the values of the two tunable parameters needed to achieve impedance matching as functions of the varying R of the inductive element, and the associated variation of the output power (at given DC bus voltage) of the amplifier for $f=250$ kHz, $C_1=10$ nF, $C_2=7.5$ nF and $\omega L'=1000\Omega$. It can be inferred from FIG. **11C** that the output power is a non-monotonic function of R . These embodiments may be able to achieve dynamic impedance matching when variations in L (and thus the resonant frequency) are modest.

[0153] In some embodiments, dynamic impedance matching with fixed elements inside the IMN, also when L is varying greatly as explained earlier, may be achieved by varying the driving frequency of the external frequency f (e.g. the switching frequency of a switching amplifier) so that it follows the varying resonant frequency of the resonator. Using the switching frequency f and the switch duty cycle dc as the two variable parameters, full impedance matching can be achieved as R and L are varying without the need of any variable components. Then, FIG. **12** shows the values of the two tunable parameters needed to achieve impedance matching as functions of the varying R and L of the inductive element, and the associated variation of the output power (at given DC bus voltage) of the amplifier for $C_a=640$ pF, $C_1=10$ nF, $C_2=7.5$ nF and $L'=637$ μ H. It can be inferred from FIG. **12** that the frequency f needs to be tuned mainly in response to variations in L , as explained earlier.

[0154] Tunable Impedance Matching for Systems of Wireless Power Transmission

[0155] In applications of wireless power transfer the low-loss inductive element may be the coil of a source resonator coupled to one or more device resonators or other resonators, such as repeater resonators, for example. The impedance of the inductive element $R+j\omega L$ may include the reflected impedances of the other resonators on the coil of the source resonator. Variations of R and L of the inductive element may occur due to external perturbations in the vicinity of the source resonator and/or the other resonators or thermal drift of components. Variations of R and L of the inductive element may also occur during normal use of the wireless power transmission system due to relative motion of the devices and other resonators with respect to the source. The relative motion of these devices and other resonators with respect to the source, or relative motion or position of other sources, may lead to varying coupling (and thus varying reflected impedances) of the devices to the source. Furthermore, variations of R and L of the inductive element may also occur during normal use of the wireless power transmission system due to changes within the other coupled resonators, such as changes in the power draw of

their loads. All the methods and embodiments disclosed so far apply also to this case in order to achieve dynamic impedance matching of this inductive element to the external circuit driving it.

[0156] To demonstrate the presently disclosed dynamic impedance matching methods for a wireless power transmission system, consider a source resonator including a low-loss source coil, which is inductively coupled to the device coil of a device resonator driving a resistive load.

[0157] In some embodiments, dynamic impedance matching may be achieved at the source circuit. In some embodiments, dynamic impedance matching may also be achieved at the device circuit. When full impedance matching is obtained (both at the source and the device), the effective resistance of the source inductive element (namely the resistance of the source coil R_s plus the reflected impedance from the device) is $R=R_s\sqrt{1+U_{sd}^2}$. (Similarly the effective resistance of the device inductive element is $R_d\sqrt{1+U_{sd}^2}$, where R_d is the resistance of the device coil.) Dynamic variation of the mutual inductance between the coils due to motion results in a dynamic variation of $U_{sd}=\omega M_{sd}\sqrt{R_s R_d}$. Therefore, when both source and device are dynamically tuned, the variation of mutual inductance is seen from the source circuit side as a variation in the source inductive element resistance R . Note that in this type of variation, the resonant frequencies of the resonators may not change substantially, since L may not be changing. Therefore, all the methods and examples presented for dynamic impedance matching may be used for the source circuit of the wireless power transmission system.

[0158] Note that, since the resistance R represents both the source coil and the reflected impedances of the device coils to the source coil, in FIGS. 9-12, as R increases due to the increasing U , the associated wireless power transmission efficiency increases. In some embodiments, an approximately constant power may be required at the load driven by the device circuitry. To achieve a constant level of power transmitted to the device, the required output power of the source circuit may need to decrease as U increases. If dynamic impedance matching is achieved via tuning some of the amplifier parameters, the output power of the amplifier may vary accordingly. In some embodiments, the automatic variation of the output power is preferred to be monotonically decreasing with R , so that it matches the constant device power requirement. In embodiments where the output power level is accomplished by adjusting the DC driving voltage of the power generator, using an impedance matching set of tunable parameters which leads to monotonically decreasing output power vs. R will imply that constant power can be kept at the power load in the device with only a moderate adjustment of the DC driving voltage. In embodiments, where the “knob” to adjust the output power level is the duty cycle dc or the phase of a switching amplifier or a component inside an Impedance Matching Network, using an impedance matching set of tunable parameters which leads to monotonically decreasing output power vs. R will imply that constant power can be kept at the power load in the device with only a moderate adjustment of this power “knob”.

[0159] In the examples of FIGS. 9-12, if $R_s=0.19\Omega$, then the range $R=0.2-2\Omega$ corresponds approximately to $U_{sd}=0.3-10.5$. For these values, in FIG. 14, we show with dashed lines the output power (normalized to DC voltage squared) required to keep a constant power level at the load, when

both source and device are dynamically impedance matched. The similar trend between the solid and dashed lines explains why a set of tunable parameters with such a variation of output power may be preferable.

[0160] In some embodiments, dynamic impedance matching may be achieved at the source circuit, but impedance matching may not be achieved or may only partially be achieved at the device circuit. As the mutual inductance between the source and device coils varies, the varying reflected impedance of the device to the source may result in a variation of both the effective resistance R and the effective inductance L of the source inductive element. The methods presented so far for dynamic impedance matching are applicable and can be used for the tunable source circuit of the wireless power transmission system.

[0161] As an example, consider the circuit of FIG. 14, where $f=250$ kHz, $C_a=640$ pF, $R_s=0.19\Omega$, $L_s=100$ μ H, $C_{1s}=10$ nF, $\omega L_s=1000\Omega$, $R_d=0.3\Omega$, $L_d=40$ μ H, $C_{1d}=87.5$ nF, $C_{2d}=13$ nF, $\omega L_d=400\Omega$ and $Z_1=50\Omega$, where s and d denote the source and device resonators respectively and the system is matched at $U_{sd}=3$. Tuning the duty cycle dc of the switching amplifier and the capacitor C_2 s may be used to dynamically impedance match the source, as the non-tunable device is moving relatively to the source changing the mutual inductance M between the source and the device. In FIG. 14, we show the required values of the tunable parameters along with the output power per DC voltage of the amplifier. The dashed line again indicates the output power of the amplifier that would be needed so that the power at the load is a constant value.

[0162] In some embodiments, tuning the driving frequency f of the source driving circuit may still be used to achieve dynamic impedance matching at the source for a system of wireless power transmission between the source and one or more devices. As explained earlier, this method enables full dynamic impedance matching of the source, even when there are variations in the source inductance L_s and thus the source resonant frequency. For efficient power transmission from the source to the devices, the device resonant frequencies must be tuned to follow the variations of the matched driving and source-resonant frequencies. Tuning a device capacitance (for example, in the embodiment of FIG. 13 C_{1d} or C_{2d}) may be necessary, when there are variations in the resonant frequency of either the source or the device resonators. In fact, in a wireless power transfer system with multiple sources and devices, tuning the driving frequency alleviates the need to tune only one source-object resonant frequency, however, all the rest of the objects may need a mechanism (such as a tunable capacitance) to tune their resonant frequencies to match the driving frequency.

[0163] Adjustable Source Size

[0164] The efficiency of wireless power transfer methods decreases with the separation distance between a source and a device. The efficiency of wireless power transfer at certain separations between the source and device resonators may be improved with a source that has an adjustable size. The inventors have discovered that the efficiency of wireless power transfer at fixed separations can be optimized by adjusting the relative size of the source and device resonators. For a fixed size and geometry of a device resonator, a source resonator may be sized to optimize the efficiency of wireless power transfer at a certain separations, positions, and/or orientations. When the source and device resonators are close to each other, power transfer efficiency may be

optimized when the characteristic sizes or the effective sizes of the resonators are similar. At larger separations, the power transfer efficiency may be optimized by increasing the effective size of the source resonator relative to the device resonator. The source may be configured to change or adjust the source resonator size as a device moves closer or further away from the source, so as to optimize the power transfer efficiency or to achieve a certain desired power transfer efficiency.

[0165] In examples in this section we may describe wireless power transfer systems and methods for which only the source has an adjustable size. It is to be understood that the device may also be of an adjustable size and achieve many of the same benefits. In some systems both the source and the device may be of an adjustable size, or in other systems only the source, or only the device may be of an adjustable size. Systems with only the source being of an adjustable size may be more practical in certain situations. In many practical designs the device size may be fixed or constrained, such as by the physical dimensions of the device into which the device resonator must be integrated, by cost, by weight, and the like, making an adjustable size device resonator impractical or more difficult to implement. It should be apparent to those skilled in the art, however, that the techniques described herein can be used in systems with an adjustable size device, an adjustable size source, or both.

[0166] In this section we may refer to the “effective size” of the resonator rather than the “physical size” of the resonator. The physical size of the resonator may be quantified by the characteristic size of the resonator (the radius of the smallest circle that encompasses an effectively 2-D resonator, for example). The effective size refers to the size or extent of the surface area circumscribed by the current-carrying inductive element in the resonator structure. If the inductive element comprises a series of concentric loops with decreasing radii, connected to each other by a collection of switches, for example, the physical size of the resonator may be given by the radius of the largest loop in the structure, while the effective size of the resonator will be determined by the radius of the largest loop that is “switched into” the inductor and is carrying current.

[0167] In some embodiments, the effective size of the resonator may be smaller than the physical size of the resonator, for example, when a small part of the conductor comprising the resonator is energized. Likewise, the effective size of the resonator may be larger than the physical size of the resonator. For example, as described below in one of the embodiments of the invention, when multiple individual resonators with given physical sizes are arranged to create a resonator array, grid, multi-element pattern, and the like, the effective size of the resonator array may be larger than the physical size of any of the individual resonators.

[0168] The relationship between wireless power transfer efficiency and source-device resonator separation is shown in FIG. 15A. The plot in FIG. 15A shows the wireless power transfer efficiency for the configuration shown in FIG. 15B where the source 5902 and device 5901 capacitively loaded conductor loop resonators are on axis 5903 (centered) and parallel to each other. The plot is shown for a fixed size 5 cm by 5 cm device resonator 5901 and three different size source resonators 5902, 5 cm×5 cm, 10 cm×10 cm and 20 cm×20 cm for a range of separation distances 5906. Note that the efficiency of wireless power transfer at different separations may depend on the relative sizes of the source

and device resonators. That is, the size of the source resonator that results in the most efficient wireless power transfer may be different for different separations between the source and the device resonators. For the configuration captured by the plot in FIG. 15A, for example, at smaller separations the efficiency is highest when the source and device resonators are sized to be substantially equal. For larger separations, the efficiency of wireless power transfer is highest when the source resonator is substantially larger than the device resonator.

[0169] The inventors have discovered that for wireless power transfer systems in which the separation between the source and device resonators changes, there may be a benefit to a source that can be configured to have various effective resonator sizes. As a device is brought closer to or further away from the source, the source resonator may change its effective resonator size to optimize the power transfer efficiency or to operate in a range of desired transfer efficiencies. Such adjustment of the effective resonator size may be manual or automatic and may be part of the overall system control, tracking, operating, stabilization and optimization architectures.

[0170] A wireless power transfer system with an adjustable source size may also be beneficial when all devices that are to be powered by the source do not have similarly sized device resonators. At a fixed separation between a source and a device, devices with two different sizes of device resonators may realize maximum transfer efficiency for different sized source resonators. Then, depending on the charging protocols and the device power requirements and hierarchies, the source may alter its size to preferentially charge or power one of the devices, a class of devices, all of the devices, and the like.

[0171] Furthermore, an additional benefit from an adjustable size source may be obtained when a single source may be required to simultaneously power multiple devices. As more devices require power, the spatial location or the area circumscribed by the source resonator or the active area of the source resonator may need to change. For example, if multiple devices are positioned in an area but are separated from each other, the source may need to be enlarged in order to energize the larger area that includes all the multiple devices. As the number of devices requiring power changes, or their spatial distribution and locations change with respect to the source, an adjustable size source may change its size to change the characteristics and the spatial distribution of the magnetic fields around the source. For example, when a source is required to transfer power to a single device, a relatively smaller source size with the appropriate spatial distribution of the magnetic field may be used to achieve the desired wireless power transfer efficiency. When the source is required to transfer power to multiple devices, a larger source size or a source with a different spatial distribution of the magnetic field may be beneficial since the devices may be in multiple locations around the source. As the number of devices that require power changes, or their distributions or power requirements change, an adjustable size source may change its size to adjust, maximize, optimize, exceed, or meet its operating parameters and specifications.

[0172] Another possible benefit of an adjustable source size may be in reducing power transfer inefficiencies associated with uncertainty or variability of the location of a device with respect to the source. For example, a device with a certain lateral displacement relative to the source may

experience reduced power transfer efficiencies. The plot in FIG. 16A shows the wireless power transfer efficiency for the configuration shown in FIG. 16B where the source **6002** and device **6001** capacitively loaded conductor loop resonators are parallel to each other but have a lateral offset **6008** between their center axes **6006**, **6005**. The plot in FIG. 16A shows power transfer efficiency for a 5 cm×5 cm device resonator **6001** separated from a parallel oriented 5 cm×5 cm source resonator **6002** (bold line) or a 20 cm×20 cm source resonator **6002** (dotted line) by 2 cm **6008**. Note that at a lateral offset **6007** of approximately 5 cm from the 5 cm×5 cm source resonator (from the center of the device resonator to the center of the source resonator), there is a “dead spot” in the power transfer efficiency. That is, the transfer efficiency is minimized or approaches zero at a particular source-device offset. The dashed line in FIG. 16A shows that the wireless power transfer efficiency for the same device at the same separation and same lateral offset but with the source size adjusted to 20 cm by 20 cm may be greater than 90%. The adjustment of the source size from 5 cm×5 cm to 20 cm×20 cm moves the location of the “dead spot” from a lateral offset of approximately 5 cm to a lateral offset of greater than 10 cm. In this example, adjusting the source size increases the wireless power transfer efficiency from almost zero to greater than 90%. Note that the 20 cm×20 cm source is less efficient transferring power to the 5 cm×5 cm device resonator when the two resonators are on axis, or centered, or are laterally offset by less than approximately 2 to 3 cm. In embodiments, a change in source size may be used to move the location of a charging or powering dead spot, or transfer efficiency minimum, allowing greater positioning flexibility for and/or higher coupling efficiency to, a device.

[0173] In some embodiments, a source with an adjustable size may be implemented as a bank of resonators of various sizes that are selectively driven by a power source or by power and control circuitry. Based on predetermined requirements, calculated requirements, from information from a monitoring, sensing or feedback signal, communication, and the like, an appropriately sized source resonator may be driven by a power source and/or by power and control circuitry and that size may be adjusted as the requirements or distances between the source and the device resonators change. A possible arrangement of a bank of differently sized resonators is shown in FIG. 17 which depicts a bank of three differently sized resonators. In the example of FIG. 17, the three resonators **6101**, **6102**, **6103** are arranged concentrically and coupled to power and control circuitry **6104**. The bank of resonators may have other configurations and arrangements. The different resonators may be placed side by side as in FIG. 18, arranged in an array, and the like.

[0174] Each resonator in a multi-size resonator bank may have its own power and control circuitry, or they each may be switched in and selectively connected to one or more power and control circuits by switches, relays, transistors, and the like. In some systems, each of the resonators may be coupled to power and control circuitry inductively. In other systems, each of the resonators may be coupled to power and control circuitry through additional networks of electronic components. A three resonator configuration with additional circuitry **6201**, **6202**, **6203** is shown in FIG. 18. In some systems, the additional circuitry **6201**, **6202**, **6203** may be used for impedance matching between each of the resonators **6101**, **6102**, **6103** and the power and control circuitry **6204**.

In some systems it may be advantageous to make each of the resonators and its respective additional circuitry have the same effective impedance as seen from the power and control circuitry. In some embodiments the effective impedance of each resonator and additional impedance matching network may be matched to the characteristic impedance of the power source or the power and control circuitry. The same effective impedance for all of the resonators may make switching between resonators in a resonator bank easier, more efficient, or quicker and may require less tuning or tunable components in the power and control circuitry.

[0175] In some embodiments of the system with a bank of multi-sized resonators, the additional circuitry **6201**, **6202**, **6203** may also include additional transistors, switches, relays, and the like, which disable, deactivate, or detune a resonator when not driven or powered by the power and control circuitry. In some embodiments of the system, not all of the resonators in a resonator bank of a source may be powered or driven simultaneously. In such embodiments of the system, it may be desirable to disable, or detune the non-active resonators to reduce energy losses in power transfer due to energy absorption by the unpowered resonators of the source. The unpowered resonators of the source may be deactivated or detuned from the resonant frequency of the other resonators by open circuiting, disrupting, grounding, or cutting the conductor of the resonator. Transistors, switches, relays and the like may be used to selectively open or close electrical paths in the conductor part of a resonator. An unpowered resonator may be likewise detuned or deactivated by removing or adding capacitance or inductance to the resonator with switches, transistors, relays, and the like. In some embodiments, the natural state of individual resonators may be to be detuned from the system operating frequency and to use signals or power from the drive signal to appropriately tune the resonator as it is activated in the bank.

[0176] In some embodiments of a system of a source with a bank of multi-sized resonators, multiple resonators may be driven by one or more power and control circuits simultaneously. In some embodiments of the system powered resonators may be driven out of phase to extend or direct the wireless power transfer. Constructive and destructive interference between the oscillating magnetic fields of multiple resonators driven in-phase or out of phase or at any relative phase or phases may be used to create specific “hotspots” or areas of concentrated magnetic energy. In embodiments, the position of these hotspots may be variable and may be moved around to achieve the desired wireless power transfer efficiencies to devices that are moving around or to address devices at different locations, orientations, and the like. In embodiments, the multi-sized source resonator may be adjusted to implement a power distribution and/or sharing algorithm and/or protocol.

[0177] In some embodiments of a bank of multi-sized resonators, the resonators may all have substantially similar parameters and characteristics despite the differences in their size. For example, the resonators may all have similar impedance, resonant frequency, quality factor, wire gauge, winding spacing, number of turns, power levels, and the like. The properties and characteristics of the resonators may be within 20% of their values.

[0178] In other embodiments of a bank of multi-sized resonators, the resonators may have non-identical parameters and characteristics tailored or optimized for the size of

each resonator. For example, in some embodiments the number of turns of a conductor for the larger resonator may be less than for the smallest resonator. Likewise, since the larger resonator may be intended for powering devices that are at a distance from the resonator, the unloaded impedance of the large resonator may be different than that of the small resonator that is intended for powering devices that are closer to the resonator to compensate for the differences in effective loading on the respective resonators due to the differences in separation. In other embodiments, the resonators may have different or variable Q's, they may have different shapes and thicknesses, they may be composed of different inductive and capacitive elements and different conducting materials. In embodiments, the variable source may be custom designed for a specific application.

[0179] In other embodiments, a source with an adjustable size may be realized as an array or grid of similarly sized resonators. Power and control circuitry of the array may selectively drive one or more resonators to change the effective size of the resonator. For example, a possible configuration of a grid of resonators is shown in FIG. 19. A grid of similarly sized resonators **6301** may be arranged in a grid and coupled to one or more power and control circuits (not shown). Each of the resonators **6301** of the array can be individually powered or any number of the resonators may be powered simultaneously. In the array, the effective size of the resonator may be changed by controlling the number, location, and driving characteristics (e.g. drive signal phase, phase offset, amplitude, and the like) of the powered resonators. For example, for the array of resonators in FIG. 19, the effective size of the resonator may be controlled by changing which individual resonators of the array are powered. The resonator may power only one of the resonators resulting in an effective resonator size **6304** which is equal to the size of one of the individual resonators. Alternatively, four of the individual resonators in the upper left portion of the array may be energized simultaneously creating an effective resonator size **6303** that may be approximately twice the size of each of the individual resonators. All of the resonators may also be energized simultaneously resulting in an effective resonator size **6302** that may be approximately three (3) times larger than the physical size each of the individual resonators.

[0180] In embodiments, the size of the array of individual resonators may be scaled to any size. In larger embodiments it may be impractical to have power and control circuitry for every individual resonator due to cost, wiring constraints, and the like. A switching bar of a cross-switch may be used to connect any of the individual resonators to as few power and control circuits as needed.

[0181] In embodiments of the array of individual resonators, the pattern of the individual energized resonators may be modified or optimized. The shape of the effective resonator may be rectangular, triangular, square, circular, or any arbitrary shape.

[0182] In embodiments of arrays of resonators, which resonators get energized may depend on the separation or distance, the lateral offset, the orientation, and the like, between the device resonator and the source resonator. The number of resonators that may be driven may, for example, depend on the distance and/or the orientation between the device resonators and the source resonators, the number of device resonators, their various power requirements, and the like. The location of the energized resonators in the array or

grid may be determined according to the lateral position of the device with respect to the source. For example, in a large array of smaller individual resonators that may cover a floor of a room or a surface of a desk, the number of energized resonators may change as the distance between the device and the floor or desk changes. Likewise, as the device is moved around a room or a desk the location of the energized resonators in the array may change.

[0183] In another embodiment, an adjustable size source resonator may be realized with an array of multi-sized resonators. Several small equally sized resonators may be arranged to make a small assembly of small resonators. The small array may be surrounded by a larger sized resonator to make a larger assembly. The larger assembly may itself be arranged in an array forming a yet larger array with an even larger resonator that may surround the larger array which itself may be arranged in an array, and so on. In this arrangement, the source resonator comprises resonators of various physical sizes distributed throughout the array. An example diagram of an arrangement of resonators is shown in FIG. 20. Smaller resonators **6401** may be arranged in two by two arrays and surrounded by another resonator with a larger physical size **6402**, forming an assembly of resonators. That assembly of resonators may be arranged in a two by two array and surrounded by a resonator with an even larger physical size **6403**. The pattern can be repeated to make a larger array. The number of times each resonator or assembly of resonators is repeated may be configured and optimized and may or may not be symmetric. In the example of FIG. 20, each resonator and assembly may be repeated in a two by two array, but any other dimension of array may be suitable. Note that the arrays may be circular, square, rectangular, triangular, diamond shaped, and the like, or any combination of shapes and sizes. The use of multi-sized resonators in an array may have a benefit in that it may not require that multiple resonators be energized to result in a larger effective resonator. This feature may simplify the power and control circuitry of the source.

[0184] In embodiments, an adjustable source size may also be realized using planar or cored resonator structures that have a core of magnetic material wrapped with a capacitively loaded conductor, examples of which are shown in FIGS. 11, 12, and 13 and described herein. In one embodiment, as depicted in FIG. 21A, an adjustable source may be realized with a core of magnetic material **6501** and a plurality of conductors **6502**, **6503**, and **6504** wrapped around the core such that the loops of the different conductors do not overlap. The effective size of the resonator may be changed or adjusted by energizing a different number of the conductors. A larger effective resonator may be realized when several adjacent conductors are driven or energized simultaneously.

[0185] Another embodiment of an adjustable size source with a cored resonator is shown in FIG. 21B where a core of magnetic material **6505** is wrapped with a plurality of overlapping conductors **6506**, **6507**, **6508**. The conductors may be wrapped such that each extends a different distance across the magnetic core **6505**. For example, for the resonator in FIG. 21B, conductor **6508** covers the shortest distance or part of the core **6505** while conductors **6507** and **6506** each cover a longer distance. The effective size of the resonator may be adjusted by energizing a different conductor, with the smallest effective size occurring when the conductor that covers the smallest distance of the magnetic

core is energized and the largest effective size when the conductor covering the largest distance of the core is energized. Each of the conductors may be wrapped to achieve similar inductances, impedances, capacitances, and the like. The conductors may all be the same length with the covering distance modified by changing the density or spacing between the multiple loops of a conductor. In some embodiments, each conductor may be wrapped with equal spacing thereby requiring conductors of different lengths for each winding. In other embodiments the number of conductors and the wrapping of each conductor may be further optimized with non constant or varying wrapping spacing, gauge, size, and the like.

[0186] Another embodiment of an adjustable size source with a cored resonator is shown in FIG. 21C where multiple magnetic cores 6509, 6510, 6511 are gapped, or not touching, and wrapped with a plurality of conductors 6512, 6513, 6514. Each of the magnetic cores 6509, 6510, 6511 is separated with a gap 6515, 6516 and a conductor is wrapped around each magnetic core, extending past the gap and around the adjacent magnetic core. Conductors that do not span a gap between two magnetic cores, such as the conductor 6513 in FIG. 21C, may be used in some embodiments. The effective size of the resonator may be adjusted by simultaneously energizing a different number of the conductors wrapped around the core. The conductors that are wrapped around the gaps between the magnetic cores may be energized guiding the magnetic field from one core to another extending the effective size of the resonator.

[0187] As those skilled in the art will appreciate, the methods and designs depicted in FIGS. 21A-21C may be extended to planar resonators and magnetic cores having various shapes and protrusions which may enable adjustable size resonators with a variable size in multiple dimensions. For example, multiple resonators may be wrapped around the extensions of the core shaped as in FIG. 13, enabling an adjustable size resonator that has a variable size in two or more dimensions.

[0188] In embodiments an adjustable size source resonator may comprise control and feedback systems, circuits, algorithms, and architectures for determining the most effective source size for a configuration of devices or objects in the environment. The control and feedback systems may use a variety of sensors, communication channels, measurements, and the like for determining the most efficient source size. In embodiments data from sensors, measurement circuitry, communication channels and the like may be processed by a variety of algorithms that select the appropriate source size.

[0189] In embodiments the source and device may comprise a wireless communication channel such as Bluetooth, WiFi, near-field communication, or modulation of the magnetic field which may be used to communicate information allowing selection of the most appropriate or most efficient source size. The device, for example, may communicate received power, current, or voltage to the source, which may be used by the source to determine the efficiency of power transfer. The device may communicate its position or relative position which may be used to calculate the separation distance between the source and device and used to determine the appropriate size of the source.

[0190] In embodiments the source may measure parameters of the resonator or the characteristics of the power transfer to determine the appropriate source size. The source

may employ any number of electric or electronic sensors to determine parameters of various resonators or various configurations of source resonators of the source. The source may monitor the impedance, resistance, resonant frequency, the magnitude and phase of currents and voltages, and the like, of each configuration, resonator, or size of the source. These parameters, or changes in these parameters, may be used by the source to determine the most effective source size. For example, a configuration of the source which exhibits the largest impedance difference between its unloaded state and present state may be the most appropriate or the most efficient for the state of the system.

[0191] The operating parameters and the size of the source may be changed continuously, periodically, or on demand, such as in response to a request by the device or by an operator of the system. A device may request or prompt the source to seek the most appropriate source size during specific time intervals, or when the power or voltage at the device drops below a threshold value.

[0192] FIGS. 22A-22D depict a possible way a wireless power transfer system may use an adjustable source size 6604 comprising two different sized resonators 6601, 6605 during operation in several configurations and orientations of the device resonator 6602 in one possible system embodiment. When a device with a small resonator 6602 is aligned and in close proximity, the source 6604 may energize the smaller resonator 6605 as shown in FIG. 22A. When a device with a small resonator 6602 is aligned and positioned further away, the source 6604 may energize the larger resonator 6601 as shown in FIG. 22B. When a device with a small resonator 6602 is misaligned, the source 6604 may energize the larger resonator 6602 as shown in FIG. 22C. Finally, when a device with a large resonator 6602 is present, the source 6604 may energize the larger resonator 6601 as shown in FIG. 22D to maximize the power transfer efficiency.

[0193] In embodiments an algorithm for determining the appropriate source size may be executed on a processor, gate array, or ASIC that is part of the source, connected to the source, or is in communication with the source. In embodiments, the algorithm may sequentially energize all, or a subset of possible source configurations or sizes, measure operating characteristics of the configurations and choose the source size with the most desirable characteristics.

[0194] Wireless Power Repeater Resonators

[0195] A wireless power transfer system may incorporate a repeater resonator configured to exchange energy with one or more source resonators, device resonators, or additional repeater resonators. A repeater resonator may be used to extend the range of wireless power transfer. A repeater resonator may be used to change, distribute, concentrate, enhance, and the like, the magnetic field generated by a source. A repeater resonator may be used to guide magnetic fields of a source resonator around lossy and/or metallic objects that might otherwise block the magnetic field. A repeater resonator may be used to eliminate or reduce areas of low power transfer, or areas of low magnetic field around a source. A repeater resonator may be used to improve the coupling efficiency between a source and a target device resonator or resonators, and may be used to improve the coupling between resonators with different orientations, or whose dipole moments are not favorably aligned.

[0196] An oscillating magnetic field produced by a source magnetic resonator can cause electrical currents in the

conductor part of the repeater resonator. These electrical currents may create their own magnetic field as they oscillate in the resonator thereby extending or changing the magnetic field area or the magnetic field distribution of the source.

[0197] In embodiments, a repeater resonator may operate as a source for one or more device resonators. In other embodiments, a device resonator may simultaneously receive a magnetic field and repeat a magnetic field. In still other embodiments, a resonator may alternate between operating as a source resonator, device resonator or repeater resonator. The alternation may be achieved through time multiplexing, frequency multiplexing, self-tuning, or through a centralized control algorithm. In embodiments, multiple repeater resonators may be positioned in an area and tuned in and out of resonance to achieve a spatially varying magnetic field. In embodiments, a local area of strong magnetic field may be created by an array of resonators, and the positioned of the strong field area may be moved around by changing electrical components or operating characteristics of the resonators in the array.

[0198] In embodiments a repeater resonator may be a capacitively loaded loop magnetic resonator. In embodiments a repeater resonator may be a capacitively loaded loop magnetic resonator wrapper around magnetic material. In embodiments the repeater resonator may be tuned to have a resonant frequency that is substantially equal to that of the frequency of a source or device or at least one other repeater resonator with which the repeater resonator is designed to interact or couple. In other embodiments the repeater resonator may be detuned to have a resonant frequency that is substantially greater than, or substantially less than the frequency of a source or device or at least one other repeater resonator with which the repeater resonator is designed to interact or couple. Preferably, the repeater resonator may be a high-Q magnetic resonator with an intrinsic quality factor, Q_r , of 100 or more. In some embodiments the repeater resonator may have quality factor of less than 100. In some embodiments, $\sqrt{Q_s Q_r} > 100$. In other embodiments, $\sqrt{Q_d Q_r} > 100$. In still other embodiments, $\sqrt{Q_{r1} Q_{r2}} > 100$.

[0199] In embodiments, the repeater resonator may include only the inductive and capacitive components that comprise the resonator without any additional circuitry, for connecting to sources, loads, controllers, monitors, control circuitry and the like. In some embodiments the repeater resonator may include additional control circuitry, tuning circuitry, measurement circuitry, or monitoring circuitry. Additional circuitry may be used to monitor the voltages, currents, phase, inductance, capacitance, and the like of the repeater resonator. The measured parameters of the repeater resonator may be used to adjust or tune the repeater resonator. A controller or a microcontroller may be used by the repeater resonator to actively adjust the capacitance, resonant frequency, inductance, resistance, and the like of the repeater resonator. A tunable repeater resonator may be necessary to prevent the repeater resonator from exceeding its voltage, current, temperature, or power limits. A repeater resonator may for example detune its resonant frequency to reduce the amount of power transferred to the repeater resonator, or to modulate or control how much power is transferred to other devices or resonators that couple to the repeater resonator.

[0200] In some embodiments the power and control circuitry of the repeater resonators may be powered by the

energy captured by the repeater resonator. The repeater resonator may include AC to DC, AC to AC, or DC to DC converters and regulators to provide power to the control or monitoring circuitry. In some embodiments the repeater resonator may include an additional energy storage component such as a battery or a super capacitor to supply power to the power and control circuitry during momentary or extended periods of wireless power transfer interruptions. The battery, super capacitor, or other power storage component may be periodically or continuously recharged during normal operation when the repeater resonator is within range of any wireless power source.

[0201] In some embodiments the repeater resonator may include communication or signaling capability such as WiFi, Bluetooth, near field, and the like that may be used to coordinate power transfer from a source or multiple sources to a specific location or device or to multiple locations or devices. Repeater resonators spread across a location may be signaled to selectively tune or detune from a specific resonant frequency to extend the magnetic field from a source to a specific location, area, or device. Multiple repeater resonators may be used to selectively tune, or detune, or relay power from a source to specific areas or devices.

[0202] The repeater resonators may include a device into which some, most, or all of the energy transferred or captured from the source to the repeater resonator may be available for use. The repeater resonator may provide power to one or more electric or electronic devices while relaying or extending the range of the source. In some embodiments low power consumption devices such as lights, LEDs, displays, sensors, and the like may be part of the repeater resonator.

[0203] Several possible usage configurations are shown in FIGS. 23A-23B, 24A-24B, and 25A-25B, showing example arrangements of a wireless power transfer system that includes a source resonator coupled to a power source 7400, a device resonator 7408 coupled to a device 7402, and a repeater resonator 7406. In some embodiments, a repeater resonator may be used between the source and the device resonator to extend the range of the source. In some embodiments the repeater resonator may be positioned after, and further away from the source than the device resonator as shown in FIG. 23B. For the configuration shown in FIG. 23B more efficient power transfer between the source and the device may be possible compared to if no repeater resonator was used. In embodiments of the configuration shown in FIG. 23B it may be preferable for the repeater resonator to be larger than the device resonator.

[0204] In some embodiments a repeater resonator may be used to improve coupling between non-coaxial resonators or resonators whose dipole moments are not aligned for high coupling factors or energy transfer efficiencies. For example, a repeater resonator may be used to enhance coupling between a source and a device resonator that are not coaxially aligned by placing the repeater resonator between the source and device aligning it with the device resonator as shown in FIG. 24A or aligning with the source resonator as shown in FIG. 24B.

[0205] In some embodiments multiple repeater resonators may be used to extend the wireless power transfer into multiple directions or multiple repeater resonators may one after another to extend the power transfer distance as shown in FIG. 25A. In some embodiments, a device resonator that is connected to load or electronic device may operate

simultaneously, or alternately as a repeater resonator for another device, repeater resonator, or device resonator as shown in FIG. 25B. Note that there is no theoretical limit to the number of resonators that may be used in a given system or operating scenario, but there may be practical issues that make a certain number of resonators a preferred embodiment. For example, system cost considerations may constrain the number of resonators that may be used in a certain application. System size or integration considerations may constrain the size of resonators used in certain applications.

[0206] In some embodiments the repeater resonator may have dimensions, size, or configuration that is the same as the source or device resonators. In some embodiments the repeater resonator may have dimensions, size, or configuration that is different than the source or device resonators. The repeater resonator may have a characteristic size that is larger than the device resonator or larger than the source resonator, or larger than both. A larger repeater resonator may improve the coupling between the source and the repeater resonator at a larger separation distance between the source and the device.

[0207] In some embodiments two or more repeater resonators may be used in a wireless power transfer system. In some embodiments two or more repeater resonators with two or more sources or devices may be used.

[0208] Repeater Resonator Modes of Operation

[0209] A repeater resonator may be used to enhance or improve wireless power transfer from a source to one or more resonators built into electronics that may be powered or charged on top of, next to, or inside of tables, desks, shelves, cabinets, beds, television stands, and other furniture, structures, and/or containers. A repeater resonator may be used to generate an energized surface, volume, or area on or next to furniture, structures, and/or containers, without requiring any wired electrical connections to a power source. A repeater resonator may be used to improve the coupling and wireless power transfer between a source that may be outside of the furniture, structures, and/or containers, and one or more devices in the vicinity of the furniture, structures, and/or containers.

[0210] In one exemplary embodiment depicted in FIG. 26, a repeater resonator 8504 may be used with a table surface 8502 to energize the top of the table for powering or recharging of electronic devices 8510, 8516, 8514 that have integrated or attached device resonators 8512. The repeater resonator 8504 may be used to improve the wireless power transfer from the source 8506 to the device resonators 8512.

[0211] In some embodiments the power source and source resonator may be built into walls, floors, dividers, ceilings, partitions, wall coverings, floor coverings, and the like. A piece of furniture comprising a repeater resonator may be energized by positioning the furniture and the repeater resonator close to the wall, floor, ceiling, partition, wall covering, floor covering and the like that includes the power source and source resonator. When close to the source resonator, and configured to have substantially the same resonant frequency as the source resonator, the repeater resonator may couple to the source resonator via oscillating magnetic fields generated by the source. The oscillating magnetic fields produce oscillating currents in the conductor loops of the repeater resonator generating an oscillating magnetic field, thereby extending, expanding, reorienting, concentrating, or changing the range or direction of the magnetic field generated by the power source and source

resonator alone. The furniture including the repeater resonator may be effectively “plugged in” or energized and capable of providing wireless power to devices on top, below, or next to the furniture by placing the furniture next to the wall, floor, ceiling, etc. housing the power source and source resonator without requiring any physical wires or wired electrical connections between the furniture and the power source and source resonator. Wireless power from the repeater resonator may be supplied to device resonators and electronic devices in the vicinity of the repeater resonator. Power sources may include, but are not limited to, electrical outlets, the electric grid, generators, solar panels, fuel cells, wind turbines, batteries, super-capacitors and the like.

[0212] In embodiments, a repeater resonator may enhance the coupling and the efficiency of wireless power transfer to device resonators of small characteristic size, non-optimal orientation, and/or large separation from a source resonator. As described above in this document, and as shown in FIGS. 15A-15B, 16A-16B and 23A-23B, the efficiency of wireless power transfer may be inversely proportional to the separation distance between a source and device resonator, and may be described relative to the characteristic size of the smaller of the source or device resonators. For example, a device resonator designed to be integrated into a mobile device such as a smart phone 8512, with a characteristic size of approximately 5 cm, may be much smaller than a source resonator 8506, designed to be mounted on a wall, with a characteristic size of 50 cm, and the separation between these two resonators may be 60 cm or more, or approximately twelve or more characteristic sizes of the device resonator, resulting in low power transfer efficiency. However, if a 50 cm×100 cm repeater resonator is integrated into a table, as shown in FIG. 26, the separation between the source and the repeater may be approximately one characteristic size of the source resonator, so that the efficiency of power transfer from the source to the repeater may be high. Likewise, the smart phone device resonator placed on top of the table or the repeater resonator, may have a separation distance of less than one characteristic size of the device resonator resulting in high efficiency of power transfer between the repeater resonator and the device resonator. While the total transfer efficiency between the source and device must take into account both of these coupling mechanisms, from the source to the repeater and from the repeater to the device, the use of a repeater resonator may provide for improved overall efficiency between the source and device resonators.

[0213] In embodiments, the repeater resonator may enhance the coupling and the efficiency of wireless power transfer between a source and a device if the dipole moments of the source and device resonators are not aligned or are positioned in non-favorable or non-optimal orientations. In the exemplary system configuration depicted in FIG. 26, a capacitively loaded loop source resonator integrated into the wall may have a dipole moment that is normal to the plane of the wall. Flat devices, such as mobile handsets, computers, and the like, that normally rest on a flat surface may comprise device resonators with dipole moments that are normal to the plane of the table, such as when the capacitively loaded loop resonators are integrated into one or more of the larger faces of the devices such as the back of a mobile handset or the bottom of a laptop. Such relative orientations may yield coupling and the power transfer efficiencies that are lower than if the dipole moments of the source and

device resonators were in the same plane, for example. A repeater resonator that has its dipole moment aligned with that of the dipole moment of the device resonators, as shown in FIG. 26, may increase the overall efficiency of wireless power transfer between the source and device because the large size of the repeater resonator may provide for strong coupling between the source resonator even though the dipole moments of the two resonators are orthogonal, while the orientation of the repeater resonator is favorable for coupling to the device resonator.

[0214] In the exemplary embodiment shown in FIG. 26, the direct power transfer efficiency between a 50 cm×50 cm source resonator **8506** mounted on the wall and a smartphone sized device resonator **8512** lying on top of the table, and approximately 60 cm away from the center of the source resonator, with no repeater resonator present, was calculated to be approximately 19%. Adding a 50 cm×100 cm repeater resonator as shown, and maintaining the relative position and orientation of the source and device resonators improved the coupling efficiency from the source resonator to the device resonator to approximately 60%. In this one example, the coupling efficiency from the source resonator to the repeater resonator was approximately 85% and the coupling efficiency from the repeater resonator to the device resonator was approximately 70%. Note that in this exemplary embodiment, the improvement is due both to the size and the orientation of the repeater resonator.

[0215] In embodiments of systems that use a repeater resonator such as the exemplary system depicted in FIG. 26, the repeater resonator may be integrated into the top surface of the table or furniture. In other embodiments the repeater resonator may be attached or configured to attach below the table surface. In other embodiments, the repeater resonator may be integrated in the table legs, panels, or structural supports. Repeater resonators may be integrated in table shelves, drawers, leaves, supports, and the like. In yet other embodiments the repeater resonator may be integrated into a mat, pad, cloth, potholder, and the like, that can be placed on top of a table surface. Repeater resonators may be integrated into items such as bowls, lamps, dishes, picture frames, books, tchotchkes, candle sticks, hot plates, flower arrangements, baskets, and the like.

[0216] In embodiments the repeater resonator may use a core of magnetic material or use a form of magnetic material and may use conducting surfaces to shape the field of the repeater resonator to improve coupling between the device and source resonators or to shield the repeater resonators from lossy objects that may be part of the furniture, structures, or containers.

[0217] In embodiments, in addition to the exemplary table described above, repeater resonators may be built into chairs, couches, bookshelves, carts, lamps, rugs, carpets, mats, throws, picture frames, desks, counters, closets, doors, windows, stands, islands, cabinets, hutches, fans, shades, shutters, curtains, footstools, and the like.

[0218] In embodiments, the repeater resonator may have power and control circuitry that may tune the resonator or may control and monitor any number of voltages, currents, phases, temperature, fields, and the like within the resonator and outside the resonator. The repeater resonator and the power and control circuitry may be configured to provide one or more modes of operation. The mode of operation of the repeater resonator may be configured to act only as repeater resonator. In other embodiments the mode of opera-

tion of the repeater resonator may be configured to act as a repeater resonator and/or as a source resonator. The repeater resonator may have an optional power cable or connector allowing connection to a power source such as an electrical outlet providing an energy source for the amplifiers of the power and control circuits for driving the repeater resonator turning it into a source if, for example, a source resonator is not functioning or is not in the vicinity of the furniture. In other embodiments the repeater resonator may have a third mode of operation in which it may also act as a device resonator providing a connection or a plug for connecting electrical or electronic devices to receive DC or AC power captured by the repeater resonator. In embodiments these modes be selected by the user or may be automatically selected by the power and control circuitry of the repeater resonator based on the availability of a source magnetic field, electrical power connection, or a device connection.

[0219] In embodiments the repeater resonator may be designed to operate with any number of source resonators that are integrated into walls, floors, other objects or structures. The repeater resonators may be configured to operate with sources that are retrofitted, hung, or suspended permanently or temporarily from walls, furniture, ceilings and the like.

[0220] Although the use of a repeater resonator with furniture has been described with the an exemplary embodiment depicting a table and table top devices it should be clear to those skilled in the art that the same configurations and designs may be used and deployed in a number of similar configurations, furniture articles, and devices. For example, a repeater resonator may be integrated into a television or a media stand or a cabinet such that when the cabinet or stand is placed close to a source the repeater resonator is able to transfer enough energy to power or recharge electronic devices on the stand or cabinet such as a television, movie players, remote controls, speakers, and the like.

[0221] In embodiments the repeater resonator may be integrated into a bucket or chest that can be used to store electronics, electronic toys, remote controls, game controllers, and the like. When the chest or bucket is positioned close to a source the repeater resonator may enhance power transfer from the source to the devices inside the chest or bucket with built in device resonators to allow recharging of the batteries.

[0222] Another exemplary embodiment showing the use of a repeater resonator is depicted in FIG. 27. In this embodiment the repeater resonator may be used in three different modes of operation depending on the usage and state of the power sources and consumers in the arrangement. The figure shows a handbag **8602** that is depicted as transparent to show internal components. In this exemplary embodiment, there may be a separate bag, satchel, pocket, or compartment **8606** inside the bag **8602** that may be used for storage or carrying of electronic devices **8610** such as cell-phones, MP3 players, cameras, computers, e-readers, iPads, netbooks, and the like. The compartment may be fitted with a resonator **8608** that may be operated in at least three modes of operation. In one mode, the resonator **8608** may be coupled to power and control circuitry that may include rechargeable or replaceable batteries or battery packs or other types of portable power supplies **8604** and may operate as a wireless power source for wirelessly recharging or powering the electronic devices located in the

handbag **8602** or the handbag compartment **8606**. In this configuration and setting, the bag and the compartment may be used as a portable, wireless recharging or power station for electronics.

[0223] The resonator **8608** may also be used as a repeater resonator extending the wireless power transfer from an external source to improve coupling and wireless power transfer efficiency between the external source and source resonator (not shown) and the device resonators **8612** of the device **8610** inside the bag or the compartment. The repeater resonator may be larger than the device resonators inside the bag or the compartment and may have improved coupling to the source.

[0224] In another mode, the resonator may be used as a repeater resonator that both supplies power to electronic devices and to a portable power supply used in a wireless power source. When positioned close to an external source or source resonator the captured wireless energy may be used by a repeater resonator to charge the battery **8604** or to recharge the portable energy source of the compartment **8606** allowing its future use as a source resonator. The whole bag with the devices may be placed near a source resonator allowing both recharging of the compartment battery **8604** and the batteries of the devices **8610** inside the compartment **8606** or the bag **8602**.

[0225] In embodiments the compartment may be built into a bag or container or may be an additional or independent compartment that may be placed into any bag or storage enclosure such as a backpack, purse, shopping bag, luggage, device cases, and the like.

[0226] In embodiments, the resonator may comprise switches that couple the power and control circuitry into and out of the resonator circuit so that the resonator may be configured only as a source resonator, only as a repeater resonator, or simultaneously or intermittently as any combination of a source, device and repeater resonator. An exemplary block diagram of a circuit configuration capable of controlling and switching a resonator between the three modes of operation is shown in FIG. **28**. In this configuration a capacitively loaded conducting loop **8608** is coupled to a tuning network **8728** to form a resonator. The tuning network **8728** may be used to set, configure, or modify the resonant frequency, impedance, resistance, and the like of the resonator. The resonator may be coupled to a switching element **8702**, comprising any number of solid state switches, relays, and the like, that may couple or connect the resonator to either one of at least two circuitry branches, a device circuit branch **8704** or a source circuit branch **8706**, or may be used to disconnect from any of the at least two circuit branches during an inactive state or for certain repeater modes of operation. A device circuit branch **8704** may be used when the resonator is operating in a repeater or device mode. A device circuit branch **8704** may convert electrical energy of the resonator to specific DC or AC voltages required by a device, load, battery, and the like and may comprise an impedance matching network **8708**, a rectifier **8710**, DC to DC or DC to AC converters **8710**, and any devices, loads, or batteries requiring power **8714**. A device circuit branch may be active during a device mode of operation and/or during a repeater mode of operation. During a repeater mode of operation, a device circuit branch may be configured to drain some power from the resonator to power or charge a load while the resonator is simultane-

ously repeating the oscillating magnetic fields from an external source to another resonator.

[0227] A source circuit branch **8706** may be used during repeater and/or source mode of operation of the resonator. A source circuit branch **8706** may provide oscillating electrical energy to drive the resonator to generate oscillating magnetic fields that may be used to wirelessly transfer power to other resonators. A source circuit branch may comprise a power source **8722**, which may be the same energy storage device such as a battery that is charged during a device mode operation of the resonator. A source circuit branch may comprise DC to AC or AC to AC converters **8720** to convert the voltages of a power source to produce oscillating voltages that may be used to drive the resonator through an impedance matching network **8716**. A source circuit branch may be active during a source mode of operation and/or during a repeater mode of operation of the resonator allowing wireless power transfer from the power source **8722** to other resonators. During a repeater mode of operation, a source circuit branch may be used to amplify or supplement power to the resonator. During a repeater mode of operation, the external magnetic field may be too weak to allow the repeater resonator to transfer or repeat a strong enough field to power or charge a device. The power from the power source **8722** may be used to supplement the oscillating voltages induced in the resonator **8608** from the external magnetic field to generate a stronger oscillating magnetic field that may be sufficient to power or charge other devices.

[0228] In some instances, both the device and source circuit branches may be disconnected from the resonator. During a repeater mode of operation the resonator may be tuned to an appropriate fixed frequency and impedance and may operate in a passive manner. That is, in a manner where the component values in the capacitively loaded conducting loop and tuning network are not actively controlled. In some embodiments, a device circuit branch may require activation and connection during a repeater mode of operation to power control and measurement circuitry used to monitor, configure, and tune the resonator.

[0229] In embodiments, the power and control circuitry of a resonator enabled to operate in multiple modes may include a processor **8726** and measurement circuitry, such as analog to digital converters and the like, in any of the components or sub-blocks of the circuitry, to monitor the operating characteristics of the resonator and circuitry. The operating characteristics of the resonator may be interpreted and processed by the processor to tune or control parameters of the circuits or to switch between modes of operation. Voltage, current, and power sensors in the resonator, for example, may be used to determine if the resonator is within a range of an external magnetic field, or if a device is present, to determine which mode of operation and which circuit branch to activate.

[0230] It is to be understood that the exemplary embodiments described and shown having a repeater resonator were limited to a single repeater resonator in the discussions to simplify the descriptions. All the examples may be extended to having multiple devices or repeater resonators with different active modes of operation.

[0231] Wireless Power Converter

[0232] In some wireless energy transfer systems and configurations a wireless energy converter may be used to convert the parameters or configurations of wireless power transfer. In some embodiments a system may have one or

more sources or one or more devices that are capable or configured to operate and transfer wireless energy with one or more different and possibly incompatible parameters. A wireless energy converter may be used to translate or convert the parameters or characteristics of wireless power transfer allowing energy transfer between sources and devices that may be configured to receive or capture wireless energy with incompatible or different parameters. Note that throughout this disclosure we may use the terms wireless power converter, wireless energy converter, wireless converter, and wireless power conversion, wireless energy conversion, and wireless conversion interchangeably.

[0233] In embodiments a wireless power converter may be used to convert the characteristics of wireless power transfer and allow power transfer between a source and a device that may be designed or configured for wireless energy transfer with different parameters or characteristics. For example, a source resonator may be configured or designed to operate at a specific resonant frequency and may transfer energy via oscillating magnetic fields at that frequency. A device resonator may be configured or designed to operate at a different resonant frequency and may be designed or configured to receive energy wirelessly only if the oscillating magnetic fields are at, or close to, the device resonant frequency. If the resonant frequencies of the source and device are substantially different, very little or no energy may be transferred. A wireless power converter may be used to convert the wireless energy transferred by the source to have characteristics or parameters such that the wireless energy may be utilized by the device. A wireless power converter may, for example, may receive energy via oscillating magnetic fields at one frequency and use the captured energy to generate oscillating magnetic fields at a different frequency that may be utilized and received by the device with a different resonant frequency than the source.

[0234] FIGS. 29A and 29B show exemplary functionality and uses of a wireless power converter. In wireless energy transfer systems one or more sources **8810** may generate oscillating magnetic fields **8814** at one or more frequencies. A wireless power converter **8808** may couple to the source **8810** and capture the energy from the oscillating magnetic field **8814** and transfer some or all of the captured energy by generating an oscillating magnetic field **8816** at one or more frequencies that may be different from the source resonator frequencies and that may be utilized by the device **8812**. It is important to note that the wireless power converter **8808** may not need to be located between the source **8810** and the device **8812**, but only in the general vicinity of both the source and device. Note that if a device is configured to operate or receive energy with different parameters or characteristics than what is generated by a source, the device may not receive significant amounts of power from the source, even if the source and device are close together. In embodiments, a wireless power converter may be used to adapt the parameters of the source to parameters that may be received by the device and may increase the efficiency of the wireless power transfer between what would be an incompatible source and device, in the absence of the converter. In some embodiments the wireless power converter may also serve as a repeater resonator and may extend, enhance, or modify the range of the wireless power transfer when it is placed between a source and a device or in the vicinity of the device.

[0235] A wireless power converter may be beneficial for many wireless power systems and applications. In some embodiments the wireless power converter may be used to convert the characteristics of wireless power transfer between normally incompatible resonators or wireless power transfer systems.

[0236] In some embodiments the wireless power converters may be utilized by the wireless power transfer system to manage, separate, or enhance the wireless power distribution between sources and devices of different power demands, power outputs, and the like. In embodiments, some wireless power transfer systems and configurations may employ devices with different power demands. Some devices in a system may have power demands for several hundred watts of power while other devices may require only a few watts of power or less. In systems without a wireless power converter, such differences in power demands and device power requirements may impose additional design constraints and limitations on the hardware and operation of the devices. For example, in a system where all devices are configured to operate at the same frequency, the devices with lower power demands of a few watts may need to be designed to withstand the voltages, currents, and magnetic field strengths equal to those of a device requiring several hundreds of watts of power. In embodiments, circuit components comprised by lower power device resonators may be required to dissipate large amounts of power as heat. One way to reduce the high voltage, current, power, and the like, requirements on lower power devices may be to detune the lower power device resonant frequency from the high power source resonant frequency, or to use frequency hopping or time multiplexing techniques to periodically, or at adjustable intervals, decouple the device from the source. These schemes may reduce the average power received by the device, and may expand the range of components that may be used in the device because components capable of withstanding high voltages, currents, powers, and the like, for short periods of time, may be smaller, less expensive, and more capable than components that must sustain such voltages, currents and powers, for extended periods of time, or for continuous operation.

[0237] In embodiments, such as when the resonant frequency of a device is not tunable, or when the resonant frequency can be tuned to an operating point that supports wireless power transmission between a high power source and a lower power device, a wireless power converter may be used to support wireless power transfer.

[0238] In an exemplary embodiment, a wireless power configuration may wirelessly transfer two hundred watts or more of power from a source in a wall to a television. In such an embodiment, it may be useful to also supply wireless power to television remote controllers, game controllers, additional displays, DVD players, music players, cable boxes, and the like, that may be placed in the vicinity of the television. Each of these devices may require different power levels and may require power levels much lower than is available from the source. In such an embodiment, it may not be possible to adjust the power available at the source without disrupting the operation of the television, for example. In addition, the television remote controllers, game controllers, additional displays, DVD players, music players, cable boxes, and the like, may also be able to receive power from other wireless power sources, such as a lower power energized surface source, situated on a shelf or a

table, as shown in FIG. 15 for example. Without a wireless power converter, it may be necessary to design the wireless power transfer hardware of the lower power devices to withstand the voltages, currents, and magnetic fields generated by a source capable of supplying hundreds of watts to a television, as well as to be efficient when the lower power devices receive power from a lower power energized surface source, for example. Circuits may be designed for the lower power devices that enable this type of operation, but in some embodiments, it may be preferable to optimize the lower power device circuits for operation with lower power sources, and to use a power converter to convert the high power levels available from a high power source to lower power levels, in some region of operation. A wireless power converter may capture some of the wireless energy generated by a high power source, may condition that power according to a variety of system requirements, and may resupply the conditioned power at different frequencies, power levels, magnetic field strengths, intervals, and the like, suitable for reception by the lower power devices referred to in this exemplary embodiment.

[0239] In some embodiments, for example, it may be preferable to operate high power devices requiring 50 watts of power or more at the lower frequencies such as in the range of 100 kHz to 500 kHz. Allowable magnetic field limits for safety considerations are relatively higher, and radiated power levels may be lower at lower operating frequencies. In some embodiments it may be preferable to operate smaller, lower power devices requiring 50 watts of power or less at higher frequencies of 500 kHz or more, to realize higher Q resonators and/or to utilize electric and electronic components such as capacitors, inductors, AC to DC converters, and the like, that may be smaller or more efficient allowing for smaller and/or tighter resonator and power and control circuitry integration.

[0240] In embodiments a wireless power converter may be used to convert wireless power transferred from multiple sources with different parameters to a single source and may be used to convert wireless power parameters to be compatible with more than one device. In embodiments a wireless power converter may be used to amplify a specific wireless power source by converting wireless power from other sources working with different parameters.

[0241] Exemplary embodiments of wireless power transfer system configurations employing wireless power converters are depicted in FIG. 30. As part of the configuration, a wireless power converter 8914 may capture energy from oscillating magnetic fields 8932, 8930 from one or more sources 8922, 8924 that may be configured or designed to operate with different parameters. The wireless power converter 8914 may capture the energy and generate a magnetic field 8934, 8936, 8938 with one or more different parameters than the sources 8922, 8924 from which the energy was received and transfer the energy to one or more devices 8916, 8918, 8920. In another aspect of the configuration, a wireless power converter 8914 may be used to capture energy from one or more sources 8922, 8924 that may be designed to operate with different parameters and generate a magnetic field 8934 with parameters that match the field 8928 of another source 8926 providing "amplification" or a boost to a field from sources 8922, 8924 and fields 8930, 8932 with different parameters.

[0242] In embodiments a wireless power converter may comprise one or more magnetic resonators configured or

configurable to capture wireless energy with one or more parameters and one or more resonators configured or configurable to transfer wireless energy with one or more parameters. For example, a wireless power converter designed to convert the frequency parameter of an oscillating magnetic field is depicted in FIG. 31A. The wireless power converter 9012 may have one or more magnetic resonators 9014, 9016 that are tuned or tunable to one or more frequencies. The oscillating voltages generated in the resonator 9014 by the oscillating magnetic fields 9002 may be rectified and used by a DC to AC converter 9008 to drive another resonator 9016 with oscillating currents generating an oscillating magnetic field 9004 with one or more different frequencies. In embodiments the DC to AC converter of the wireless power converter may be tuned or tunable using a controller 9010 to generate a range of frequencies and output power levels.

[0243] In embodiments the oscillating voltages of the receiving resonators 9014 may be converted to oscillating voltages at a different frequency using an AC to AC converter 9018 and used to energize a resonator 9016 of a wireless power converter without first converting the received voltages and currents to DC as depicted in FIG. 31B. In embodiments it may be preferable to configure and design a wireless power converter to convert the frequency of magnetic fields such that the captured and transferred magnetic fields are multiples of one another such that a diode, a nonlinear element, a frequency multiplier, a frequency divider, and the like, may be used to convert the frequency of the captured energy to a different frequency without first converting to a DC voltage.

[0244] In embodiments a wireless power converter may include one or more resonators that are time multiplexed between capturing energy at one frequency and transferring energy at a different frequency. The block diagram of time multiplexed power converter is depicted in FIG. 32. A time multiplexed wireless power converter 9102 may be tuned to capture oscillating magnetic fields 9104, convert the generated AC energy to DC energy using an AC to DC converter 9114, and charge an energy storage element 9108 such as a super capacitor, battery, and the like. After a period of time, the resonator 9116 may be tuned to a different frequency and the energy stored in the energy storage element 9108 may be used to power an amplifier or an DC to AC converter 9112 to drive the tuned resonator 9116 with an oscillating voltage at the new resonant frequency thereby generating an oscillating magnetic field. In embodiments the resonator 9116 may change from capturing to transferring power every few milliseconds, seconds, or minutes. The resonator may be configured to change from capturing to transferring of power as soon as energy in the storage element reaches a predetermined level and may switch back to capturing when the energy in the storage element drops below a predetermined level. In embodiments a wireless power converter that converts power from a high power source to a device with low power requirements may only need to capture power for a small fraction of the time multiplexed cycle and slowly transmit power at the required device power level for the remainder of the cycle.

[0245] In an embodiment system utilizing wireless power converters, an area, room, or region may be flooded or energized with low power magnetic fields by multiple sources that may be integrated into walls, ceilings, partitions and the like. Different wireless power converters may be

distributed or strategically located at different locations to capture and convert the low power magnetic fields to different frequencies, parameters, and power levels to transfer power to different classes or types of devices within the area. In system embodiments utilizing wireless power converters, sources may be configured or extended to function and operate with a large number of various devices with specialized power demands or configurations without requiring changes or reconfiguration of the sources.

[0246] In embodiments a wireless power converter may not require any additional energy input and may simply convert the parameters and characteristics of wireless power transfer. In embodiments the wireless power converters may have additional energy inputs from batteries, solar panels, and the like that may be used to supplement the energy transferred.

[0247] In embodiments the wireless power converter may be tunable and configurable such that it may be tuned or configured to convert from any number of frequencies or power levels or energy multiplexing schemes to any number of frequencies or power levels or energy multiplexing schemes. It may be adjusted automatically by sensing power levels or frequencies of a source, or the source with the strongest or appropriate magnetic field, for example. The converter may include communication or signaling capability to allow configuration by a source or sources, device or devices, repeater or repeaters, master controller or controllers or other converters, as to parameters of the conversion that may be desired or required. The converter may communicate or signal to a source or sources to turn on or off, or to increase or decrease power levels, depending on the power requirements of the device or devices, repeater or repeaters, to which the converter is transferring energy or for which the converter is adapting, converting, or translating, the characteristics of the wireless power transfer.

[0248] Although many of the specific embodiments of a wireless power converter have been described in terms of a converter that changes the frequency of an oscillating magnetic field it is to be understood that frequency is an exemplary parameter and other parameters may be converted without departing from the spirit of the invention. In embodiments a power converter may change any number of parameters including phase, amplitude, and the like. In some embodiments a wireless power converter may change the sequence or timing of frequency hopping, or allow a single frequency source to power devices that employ or expect a constant or periodic frequency hopping mode of operation. In some embodiments, the converter may use time multiplexing techniques to adjust power levels, power distribution algorithms and sequences, and to implement preferential or hierarchical charging or powering services.

[0249] In embodiments a wireless power converter may convert the parameters of wireless power transfer and may also, or instead, change the distribution of the fields generated by a source field. A wireless power converter may include multi-sized or variable size resonators that may be configured to redistribute the magnetic field of a source to allow or enhance operation with a device of a different size or at different separations. In embodiments a small source resonator may not be the most efficient at transferring power to a large device resonator. Likewise, a large source resonator may not be the most efficient at transferring power to a small device resonator. A wireless power converter may include two or more differently sized resonators that capture

and redistribute the magnetic field for improved efficiency of wireless power transfer to device resonators without requiring changes or reconfiguration of the source or device resonators.

[0250] For example, as depicted in FIG. 33A, a wireless power converter 9214 with a large capture resonator 9216 and a small transmitting resonator 9218 may be placed close to a small device resonator 9212 and may improve the wireless power transfer efficiency between a large distant source resonator 9208 and a small device resonator 9212. Likewise, as depicted in FIG. 33B, a wireless power converter 9214 with a small capture resonator 9218 and a large transmitting resonator 9216 may be placed close to a small source resonator 9208 and may improve the wireless power transfer efficiency between a large distant device resonator 9212 and the small source resonator 9208. The converter resonator may include one or more capture resonators that are sized to maximize the efficiency of wireless power transfer from the source resonator to the converter resonator and one or more transfer resonators that are sized to maximize the efficiency of wireless power transfer from the converter resonator to the device resonator. In some embodiments energy captured by the capture resonator may be used to directly power the transmitting resonator. In embodiments the energy captured by the capture resonator may be converted, modified, metered or amplified before being used to energize the transmitter resonator. A wireless power converter with differently sized resonators may result in improved system efficiency.

[0251] Wireless Energy Distribution System

[0252] Wireless energy may be distributed over an area using repeater resonators. In embodiments a whole area such as a floor, ceiling, wall, table top, surface, shelf, body, area, and the like may be wirelessly energized by positioning or tiling a series of repeater resonators and source resonators over the area. In some embodiments, a group of objects comprising resonators may share power amongst themselves, and power may be wireless transmitted to and/or through various objects in the group. In an exemplary embodiment, a number of vehicles may be parked in an area and only some of the vehicles may be positioned to receive wireless power directly from a source resonator. In such embodiments, certain vehicles may retransmit and/or repeat some of the wireless power to vehicles that are not parked in positions to receive wireless power directly from a source. In embodiments, power supplied by a vehicle charging source may use repeaters to transmit power into the vehicles to power devices such as cell phones, computers, displays, navigation devices, communication devices, and the like. In some embodiments, a vehicle parked over a wireless power source may vary the ratio of the amount of power it receives and the amount of power it retransmits or repeats to other nearby vehicles. In embodiments, wireless power may be transmitted from one source to device after device and so on, in a daisy chained fashion. In embodiments, certain devices may be able to self determine how much power that receive and how much they pass on. In embodiments, power distribution amongst various devices and/or repeaters may be controlled by a master node or a centralized controller.

[0253] Some repeater resonators may be positioned in proximity to one or more source resonators. The energy from the source may be transferred from the sources to the repeaters, and from those repeaters to other repeaters, and to other repeaters, and so on. Therefore energy may be wire-

lessly delivered to a relatively large area with the use of small sized sources being the only components that require physical or wired access to an external energy source.

[0254] In embodiments the energy distribution over an area using a plurality of repeater resonators and at least one source has many potential advantages including in ease of installation, configurability, control, efficiency, adaptability, cost, and the like. For example, using a plurality of repeater resonators allows easier installation since an area may be covered by the repeater resonators in small increments, without requiring connections or wiring between the repeaters or the source and repeaters. Likewise, a plurality of smaller repeater coils allows a greater flexibility of placement allowing the arrangement and coverage of an area with an irregular shape. Furthermore, the repeater resonators may be easily moved or repositioned to change the magnetic field distribution within an area. In some embodiments the repeaters and the sources may be tunable or adjustable allowing the repeater resonators to be tuned or detuned from the source resonators and allowing a dynamic reconfiguration of energy transfer or magnetic field distribution within the area covered by the repeaters without physically moving components of the system.

[0255] For example, in one embodiment, repeater resonators and wireless energy sources may be incorporated or integrated into flooring. In embodiments, resonator may be integrated into flooring or flooring products such as carpet tiles to provide wireless power to an area, room, specific location, multiple locations and the like. Repeater resonators, source resonators, or device resonators may be integrated into the flooring and distribute wireless power from one or more sources to one more devices on the floor via a series of repeater resonators that transfer the energy from the source over an area of the floor.

[0256] It is to be understood that the techniques, system design, and methods may be applied to many flooring types, shapes, and materials including carpet, ceramic tiles, wood boards, wood panels and the like. For each type of material those skilled in the art will recognize that different techniques may be used to integrate or attach the resonators to the flooring material. For example, for carpet tiles the resonators may be sown in or glued on the underside while for ceramic tiles integration of tiles may require a slurry type material, epoxy, plaster, and the like. In some embodiments the resonators may not be integrated into the flooring material but placed under the flooring or on the flooring. The resonators may, for example, come prepackaged in padding material that is placed under the flooring. In some embodiments a series or an array or pattern of resonators, which may include source, device, and repeater resonators, may be integrated in to a large piece of material or flooring which may be cut or trimmed to size. The larger material may be trimmed in between the individual resonators without disrupting or damaging the operation of the cut piece.

[0257] Returning now to the example of the wireless floor embodiment comprising individual carpet tiles, the individual flooring tiles may be wireless power enabled by integrating or inserting a magnetic resonator to the tile or under the tile. In embodiments resonator may comprise a loop or loops of a good conductor such as Litz wire and coupled to a capacitive element providing a specific resonant frequency which may be in the range of 10 KHz to 100 MHz. In embodiments the resonator may be a high-Q resonator with a quality factor greater than 100. Those

skilled in the art will appreciate that the various designs, shaped, and methods for resonators such as planar resonators, capacitively loaded loop resonators, printed conductor loops, and the like described herein may be integrated or combined within a flooring tile or other flooring material.

[0258] Example embodiments of a wireless power enabled floor tile are depicted in FIG. 34A and FIG. 34B. A floor tile 12902 may include loops of an electrical conductor 12904 that are wound within the perimeter of the tile. In embodiments the conductor 12904 of the resonator may be coupled to additional electric or electronic components 12906 such as capacitors, power and control circuitry, communication circuitry, and the like. In other embodiments the tile may include more than one resonator and more than one loop of conductors that may be arranged in an array or a deliberate pattern as described herein such as for example a series of multisized coils, a configurable size coil and the like.

[0259] In embodiments the coils and resonators integrated into the tiles may include magnetic material. Magnetic material may be used to construct planar resonator structures such those depicted in FIGS. 34A and 34B. In embodiments the magnetic material may also be used for shielding of the coil of the resonator from lossy objects that may be under or around the flooring. In some embodiments the structures may further include a layer or sheet of a good electrical conductor under the magnetic material to increase the shielding capability of the magnetic material as described herein.

[0260] Tiles with a resonator may have various functionalities and capabilities depending on the control circuitry, communication circuitry, sensing circuitry, and the like that is coupled to the coil or resonator structure. In embodiments of a wireless power enabled flooring the system may include multiple types of wireless enabled tiles with different capabilities. One type of floor tile may comprise only a magnetic resonator and function as a fixed tuned repeater resonator that wirelessly transfers power from one resonator to another resonator without any direct or wired power source or wired power drain.

[0261] Another type of floor tile may comprise a resonator coupled to control electronics that may dynamically change or adjust the resonant frequency of the resonator by, for example, adjusting the capacitance, inductance, and the like of the resonator. The tile may further include an in-band or out-of-band communication capability such that it can exchange information with other communication enabled tiles. The tile may be then able to adjust its operating parameters such as resonant frequency in response to the received signals from the communication channel.

[0262] Another type of floor tile may comprise a resonator coupled to integrated sensors that may include temperature sensors, pressure sensors, inductive sensors, magnetic sensors, and the like. Some or all the power captured by the resonator may be used to wirelessly power the sensors and the resonator may function as a device or partially as a repeater.

[0263] Yet another type of wireless power enabled floor tile may comprise a resonator with power and control circuitry that may include an amplifier and a wired power connection for driving the resonator and function like a wireless power source. The features, functions, capabilities of each of the tiles may be chosen to satisfy specific design constraints and may feature any number of different com-

binations of resonators, power and control circuitry, amplifiers, sensors, communication capabilities and the like.

[0264] A block diagram of the components comprising a resonator tile are shown in FIG. 35. In a tile, a resonator 13002 may be optionally coupled to power and control circuitry 13006 to receive power and power devices or optional sensors 13004. Additional optional communication circuitry 13008 may be connected to the power and control circuitry and control the parameters of the resonator based on received signals.

[0265] Tiles and resonators with different features and capabilities may be used to construct a wireless energy transfer systems with various features and capabilities. One embodiment of a system may include sources and only fixed tuned repeater resonator tiles. Another system may comprise a mixture of fixed and tunable resonator tiles with communication capability. To illustrate some of the differences in system capabilities that may be achieved with different types of floor tiles we will describe example embodiments of a wireless floor system.

[0266] The first example embodiment of the wireless floor system may include a source and only fixed tuned repeater resonator tiles. In this first embodiment a plurality of fixed tuned resonator tiles may be arranged on a floor to transfer power from a source to an area or location over or next to the tiles and deliver wireless power to devices that may be placed on top of the tiles, below the tiles, or next to the tiles. The repeater resonators may be fixed tuned to a fixed frequency that may be close to the frequency of the source. An arrangement of the first example embodiment is shown in FIG. 36. The tiles 13102 are arranged in an array with at least one source resonator that may be integrated into a tile 13110 or attached to a wall 13106 and wired 13112 to a power source. Some repeater tiles may be positioned next to the source resonator and arranged to transfer the power from the source to a desired location via one or more additional repeater resonators.

[0267] Energy may be transferred to other tiles and resonators that are further away from the source resonators using tiles with repeater resonators which may be used to deliver power to devices, integrated or connected to its own device resonator and device power and control electronics that are placed on top or near the tiles. For example, power from the source resonator 13106 may be transferred wirelessly from the source 13106 to an interior area or interior tile 13122 via multiple repeater resonators 13114, 13116, 13118, 13120 that are between the interior tile 13122 and the source 13106. The interior tile 13122 may then transfer the power to a device such as a resonator built into the base of a lamp 13108. Tiles with repeater resonators may be positioned to extend the wireless energy transfer to a whole area of the floor allowing a device on top of the floor to be freely moved within the area. For example additional repeater resonator tiles 13124, 13126, 13128 may be positioned around the lamp 13108 to create a defined area of power (tiles 13114, 13116, 13118, 13120, 13122, 13124, 13126, 13128) over which the lamp may be placed to receive energy from the source via the repeater tiles. The defined area over which power is distributed may be changed by adding more repeater tiles in proximity to at least one other repeater or source tile. The tiles may be movable and configurable by the user to change the power distribution as needed or as the room configuration changes. Except a few tiles with source resonators which may need wired source or energy, each tile

may be completely wireless and may be configured or moved by the user or consumer to adjust the wireless power flooring system.

[0268] A second embodiment of the wireless floor system may include a source and one or more tunable repeater resonator tiles. In embodiments the resonators in each or some of the tiles may include control circuitry allowing dynamic or periodic adjustment of the operating parameters of the resonator. In embodiments the control circuitry may change the resonant frequency of the resonator by adjusting a variable capacitor or a changing a bank of capacitors.

[0269] To obtain maximum efficiency of power transfer or to obtain a specific distribution of power transfer in the system of multiple wireless power enabled tiles it may be necessary to adjust the operating point of each resonator and each resonator may be tuned to a different operating point. For example, in some situations or applications the required power distribution in an array of tiles may be required to be non-uniform, with higher power required on one end of the array and lower power on the opposite end of the array. Such a distribution may be obtained, for example, by slightly detuning the frequency of the resonators from the resonant frequency of the system to distribute the wireless energy where it is needed.

[0270] For example, consider the array of tiles depicted in FIG. 36 comprising 36 tunable repeater resonator tiles with a single source resonator 13106. If only one device that requires power is placed on the floor, such as the lamp 13108, it may be inefficient to distribute the energy across every tile when the energy is needed in only one section of the floor tile array. In embodiments the tuning of individual tiles may be used to change the energy transfer distribution in the array. In the example of the single lamp device 13108, the repeater tiles that are not in direct path from the source resonator 13106 to the tile closest to the device 13122 may be completely or partially detuned from the frequency of the source. Detuning of the unused repeaters reduces the interaction of the resonators with the oscillating magnetic fields changing the distribution of the magnetic fields in the floor area. With tunable repeater tiles, a second device may be placed within the array of tiles or the lamp device 13108 is moved from its current location 13122 to another tile, say 13130, the magnetic field distribution in the area of the tiles may be changed by retuning tiles that are in the path from the source 13106 to the new location 13130.

[0271] In embodiments, to help coordinate the distribution of power and tuning of the resonators the resonator may include a communication capability. Each resonator may be capable of wirelessly communicating with one or more of its neighboring tiles or any one of the tiles to establish an appropriate magnetic field distribution for a specific device arrangement.

[0272] In embodiments the tuning or adjustment of the operating point of the individual resonators to generate a desired magnetic field distribution over the area covered by the tiles may be performed in a centralized manner from one source or one "command tile". In such a configuration the central tile may gather the power requirements and the state of each resonator and each tile via wireless communication or in band communication of each tile and calculate the most appropriate operating point of each resonator for the desired power distribution or operating point of the system. The information may be communicated to each individual tile wirelessly by an additional wireless communication channel

or by modulating the magnetic field used for power transfer. The power may be distributed or metered out using protocols similar to those used in communication systems. For example, there may be devices that get guaranteed power, while others get best effort power. Power may be distributed according to a greedy algorithm, or using a token system. Many protocols that have been adapted for sharing information network resources may be adapted for sharing wireless power resources.

[0273] In other embodiments the tuning or adjustment of the operating point of the individual resonators may be performed in a decentralized manner. Each tile may adjust the operating point of its resonator on its own based on the power requirements or state of the resonators of tiles in its near proximity.

[0274] In both centralized and decentralized arrangements any number of network based centralized and distributed routing protocols may be used. For example, each tile may be considered as a node in network and shortest path, quickest path, redundant path, and the like, algorithms may be used to determine the most appropriate tuning of resonators to achieve power delivery to one or more devices.

[0275] In embodiments various centralized and decentralized routing algorithms may be used to tune and detune resonators of a system to route power via repeater resonators around lossy objects. If an object comprising lossy material is placed on some of the tiles it may the tiles, it may unnecessarily draw power from the tiles or may disrupt energy transmission if the tiles are in the path between a source and the destination tile. In embodiments the repeater tiles may be selectively tuned to bypass lossy objects that may be on the tiles. Routing protocols may be used to tune the repeater resonators such that power is routed around lossy objects.

[0276] In embodiments the tiles may include sensors. The tiles may include sensors that may be power wirelessly from the magnetic energy captured by the resonator built into the tile to detect objects, energy capture devices, people **13134**, and the like on the tiles. The tiles may include capacitive, inductive, temperature, strain, weight sensors, and the like. The information from the sensors may be used to calculate or determine the best or satisfactory magnetic field distribution to deliver power to devices and may be used to detune appropriate resonators. In embodiments the tiles may comprise sensors to detect metal objects. In embodiments the presence of a lossy object may be detected by monitoring the parameters of the resonator. Lossy objects may affect the parameters of the resonator such as resonant frequency, inductance, and the like and may be used to detect the metal object.

[0277] In embodiments the wireless powered flooring system may have more than one source and source resonators that are part of the tiles, that are located on the wall or in furniture that couple to the resonators in the flooring. In embodiments with multiple sources and source resonators the location of the sources may be used to adjust or change the power distribution within in the flooring. For example, one side of a room may have devices which require more power and may require more sources closer to the devices. In embodiments the power distribution in the floor comprising multiple tiles may be adjusted by adjusting the output power (the magnitude of the magnetic field) of each source, the phase of each source (the relative phase of the oscillating magnetic field) of each source, and the like.

[0278] In embodiments the resonator tiles may be configured to transfer energy from more than one source via the repeater resonators to a device. Resonators may be tuned or detuned to route the energy from more than one source resonator to more than one device or tile.

[0279] In embodiments with multiple sources it may be desirable to ensure that the different sources and may be different amplifiers driving the different sources are synchronized in frequency and/or phase. Sources that are operating at slightly different frequencies and/or phase may generate magnetic fields with dynamically changing amplitudes and spatial distributions (due to beating effects between the oscillating sources). In embodiments, multiple source resonators may be synchronized with a wired or wireless synchronization signal that may be generated by a source or external control unit. In some embodiments one source resonator may be designed as a master source resonator that dictates the frequency and phase to other resonators. A master resonator may operate at its nominal frequency while other source resonators detect the frequency and phase of the magnetic fields generated by the master source and synchronize their signals with that of the master.

[0280] In embodiments the wireless power from the floor tiles may be transferred to table surfaces, shelves, furniture and the like by integrating additional repeater resonators into the furniture and tables that may extend the range of the wireless energy transfer in the vertical direction from the floor. For example, in some embodiments of a wireless power enabled floor, the power delivered by the tiles may not be enough to directly charge a phone or an electronic device that may be placed on top of a table surface that may be two or three feet above the wireless power enabled tiles. The coupling between the small resonator of the electronic device on the surface of the table and the resonator of the tile may be improved by placing a large repeater resonator near the surface of the table such as on the underside of the table. The relatively large repeater resonator of the table may have good coupling with the resonator of the tiles and, due to close proximity, good coupling between the resonator of the electronic device on the surface of the table resulting in improved coupling and improved wireless power transfer between the resonator of the tile and the resonator of the device on the table.

[0281] As those skilled in the art will recognize the features and capabilities of the different embodiments described may be rearranged or combined into other configurations. A system may include any number of resonator types, source, devices, and may be deployed on floors, ceilings, walls, desks, and the like. The system described in terms of floor tiles may be deployed onto, for example, a wall and distribute wireless power on a wall or ceiling into which enabled devices may be attached or positioned to receive power and enable various applications and configurations. The system techniques may be applied to multiple resonators distributed across table tops, surfaces, shelves, bodies, vehicles, machines, clothing, furniture, and the like. Although the example embodiments described tiles or separate repeater resonators that may be arranged into different configurations based on the teachings of this disclosure it should be clear to those skilled in the art that multiple repeater or source resonator may not be attached or positioned on separate physical tiles or sheets. Multiple repeater resonators, sources, devices, and their associated power and control circuitry may be attached, printed, etched, to one tile,

sheet, substrate, and the like. For example, as depicted in FIG. 37, an array of repeater resonators 13204 may be printed, attached, or embedded onto one single sheet 13202. The single sheet 13202 may be deployed similarly as the tiles described above. The sheet of resonators may be placed near, on, or below a source resonator to distribute the wireless energy through the sheet or parts of the sheet. The sheet of resonators may be used as a configurable sized repeater resonator in that the sheet may be cut or trimmed between the different resonators such as for example along line 13206 shown in FIG. 37.

[0282] In embodiments a sheet of repeater resonators may be used in a desktop environment. Sheet of repeater resonators may be cut to size to fit the top of a desk or part of the desk, to fit inside drawers, and the like. A source resonator may be positioned next to or on top of the sheet of repeater resonators and devices such as computers, computer peripherals, portable electronics, phones, and the like may be charged or powered via the repeaters.

[0283] In embodiments resonators embedded in floor tiles or carpets can be used to capture energy for radiant floor heating. The resonators of each tile may be directly connected to a highly resistive heating element via unrectified AC, and with a local thermal sensor to maintain certain floor temperature. Each tile may be able to dissipate a few watts of power in the thermal element to heat a room or to maintain the tiles at a specific temperature.

[0284] Wireless Energy Transfer with Reduced Fields

[0285] In some wireless power transfer applications, it may be beneficial to minimize or reduce the electric and magnetic fields at a distance away from the system, at distances substantially larger than the system, and sometimes at a distance within several centimeters away from the system. The fields that need to be minimized or reduced can be either the far-field, or the near-field (if the wavelength is much larger than the distance between the wireless power transfer system to the point of interest). One would like to accomplish this without a substantial decrease of the performance of the system, and/or dramatic changes to the external geometry of the system. An opportunity for accomplishing this arises from the fact that the fields far from the system are substantially different than the fields close to the system (whose properties determine the performance of the power transfer system). Thereby, to a large extent, it may be possible to tune these two sets of fields fairly independently, ensuring that the fields far from the system are weak, or reduced, without drastically reducing the performance (efficiency, amount of power transferred) of the power transfer. Far from the system, one can decompose the fields into a multipole expansion. In this disclosure, we show how one can design the systems so that the lowest (dipole) component of the expansion is zero or nearly zero. This way, the fields far from the system will be weak, because the higher order components decay substantially faster (as a function of distance) than the dipole component. In typical wireless power transfer systems, this can often lead to reduction of the relevant fields far from the system by orders of magnitude.

[0286] In one embodiment, both the device and the source can be designed to be quadrupole magnetic resonators. With the quadrupole design the field far from the system will identically have no dipole component. In embodiments a quadrupole magnetic resonator may comprise two or more loops of a conductor configured such that the current flows

in opposite direction through each loop or series of loops. In embodiments the loops of the conductor may be co-planar. In other embodiments the loops may be oriented such that the axis of the loops are all substantially parallel. One example of a quadrupole magnetic resonator is shown in FIG. 38. In that figure, the conductor of the resonator is twisted to form two coplanar loops. When the conductor is energized with an electric current, the current will flow substantially in opposite directions in each of the loops, clockwise in one and counterclockwise in the other. Each of the two loops by itself has a magnetic dipole, but since their dipoles are identical, and the currents are circulating in them in the opposite directions, the dipole components far from the object cancel, and we are left with only a quadrupole field.

[0287] Another example of a resonator that has only a quadrupole moment is shown in FIG. 39. In the figure, the conductor of the resonator is twisted to form two coplanar and coaxial loops. The arrows in each of the figures represent the direction of the flow of the current in the corresponding part of the resonator. Like in the example of FIG. 38, when the conductor is energized with an electric current, the current will flow substantially in opposite directions in each of the loops.

[0288] In embodiments each of the loops of the conductor shown in FIGS. 38 and 39 may comprise of more than one loops of conductor. A single conductor may be first shaped to form multiple loops or turns such that the current flows in the same direction in each of the loops or turns and then formed to make an additional set of loops or turns with the current flowing in the same direction in each of the second set of loops or turns but opposite direction with respect to the first set of loops or turns.

[0289] In the embodiment of FIG. 39 it should be noted that since the loops do not have identical sizes, one has to make sure that the inner loop has more turns of wire than the outer loop to compensate; roughly, the ratio of the areas of the loops should correspond to the inverse of the ratio of the number of turns of wire.

[0290] Another embodiment of cancelation of the dipole moment may be achieved with an additional source or active resonator as illustrated in FIG. 40. In the embodiment, in addition to a source resonator (source 1) and a device resonator (device 1), an additional resonator (source R) is used whose main purpose is to cancel the dipole moment far from the system. In embodiments the current of the additional resonator (source R) is adjusted to be exactly or substantially out of phase with the source resonator (source 1). In embodiments, to get the most cancellation it may be preferable to ensure source 1 and source R are of identical or near identical sizes and have an equal number of wires, that the orientation of their dipoles are substantially the same, and that they circulate substantially the same amount of current.

[0291] Since the device shown in FIG. 40 is smaller, its contribution to the field is smaller and in some application may be neglected. Nevertheless, for some applications one can easily take the device's contribution into account. One adds the dipole moment of the device (as a complex vector) P_D to the dipole moment of the source 1 (as a complex vector) P_{S1} : they are often $\pi/2$ out of phase with respect to each other. Sometimes these vectors are parallel to each other (if source 1 and device 1 are parallel), but sometimes they are not: that is why it is crucial to add them as vectors

in this consideration. Next, one ensures that source R has the complex dipole moment $P_{SR} = -(P_{S1} + P_D)$, which will ensure that the dipole field is canceled far from the entire system shown in FIG. 40. To ensure that this is the case, one will (most generally) have to tune the orientation of the source R (to make sure the vectors are parallel), the phase of the current (so it exactly cancels the other dipole), and the current going thru it (to make sure that the magnitude of the vectors are the same). Note that if the source R is substantially larger than the source 1 and/or the device 1, even a very weak current in the source R will be sufficient: the impact on the fields close to the system (and the total power in the source R) will be very small, yet the impact on the field far from the system can be large. This scheme works better if the centers of the wireless power system and the source R are not very far from each other. The source R can be positioned fairly arbitrarily: in fact it can even be surrounding the wireless power transfer system.

[0292] In yet another embodiment the dipole component may be cancelled if one can ensure to have two (independent) wireless power transfer systems, sufficiently close to each other, operating at the same time. If the dipole moment vectors of the two systems are the same in direction and in magnitude, and one ensures to operate the systems π out of phase, the dipole component will be canceled far from the systems. Note that the intrinsic details of the systems can be substantially different (different sizes, powers, etc.): only the dipole components of the fields have to be substantially similar. A possible configuration of the system is shown in FIG. 41. The figure shows two power transfer systems, one comprising source 1 and device 1 and the other source 2 and device 2. Source 1 transfers energy to device 1 and source 2 transfers energy to device 2. The two sources and devices can transfer power to the same object (e.g. both of these systems can be installed on the same car, charging that particular single car), or they can be completely independent systems (i.e. charging two separate cars). For example, in a garage with $2N$ cars (where N is integer), one can ensure that the dipole components of all the cars cancel pair-wise far from the garage. In the case when there is an odd number of cars in the garage (e.g. 3 cars), one ensures that they are $2\pi/3$ out of phase with respect to each other, so when dipole moments of the 3 cars are added, they cancel together: $1 + e^{-i2\pi/3} + e^{-i4\pi/3} = 0$. If the dipole moment vectors of the systems are not the same, one has to make sure the sum of their complex vectors cancels far from the system, similarly as we discussed in the previous paragraph.

[0293] In embodiments of the system depicted in FIG. 41, each of the source coils may be driven and controlled by a separate amplifier operating out of phase of one another. In embodiments each of the device resonators may be connected to separate rectifier and control circuits. In other embodiments the two or more source coils may be driven by the same amplifier in series. Likewise, in some embodiments the two device resonators may be connected to the same rectifier and control circuitry.

[0294] In another embodiment a quadrupole magnetic resonator may be implemented with the use of a conducting plane positioned substantially perpendicular to the dipole moment of the resonator as depicted in FIG. 42. If one places a conducting plane below the dipole, there will be an image dipole generated below the plane. If the original dipole is perpendicular to the plane, the image dipole will be also perpendicular, but opposite. Hence, far from the object, the

field will look like a quadrupole. In fact, since the Earth itself is partially conducting, it can often provide the same purpose as a conducting plane.

[0295] In another embodiment the dipole term far from the system may be reduced by adding one or more repeater resonators, as in FIG. 43. In some wireless power transfer system, a single repeater will be $\pi/2$ out of phase with respect to the source, and $-\pi/2$ out of phase with respect to the device. This means that the source and the device are π out of phase, and that their fields tend to cancel the dipole term far from the system. If the repeater's dipole moment is substantially smaller than the source, or the device, the dipole term far from the system will be small. In embodiments, two or more repeaters can be placed between the source and device. In embodiments, an even number of repeaters placed between the source and device can improve cancellation of the far-field radiation. By tuning the phases, and geometries of the system, one could potentially reduce the dipole term far from the system even further: the fact that the system consists of 3 resonators (instead of the usual 2) provides further opportunities for dipole cancellation far from the system.

[0296] Another way to reduce the far-field dipole radiation involves configuring one or more conductors so that an electric current flows through them in a direction that creates a magnetic dipole moment that substantially opposes the magnetic dipole of the wireless energy transfer system. In embodiments, the conductors are distal from the near-field region of the wireless energy transfer system. This allows the conductors to attenuate the far-field radiation without substantially attenuating the near-field resonant energy transfer.

[0297] FIG. 44 depicts an embodiment where a conducting loop is configured so that the fringing magnetic fields from the resonators induce an oscillating current that flows through the loop. The induced current will produce a magnetic dipole M that opposes the magnetic dipole of the resonator system. The circle with a concentric dot represents magnetic field lines flowing out of the page while the circle with a cross represents magnetic field lines flowing into the page. The far-field dipole will therefore be attenuated by the partial cancellation of the resonator system's dipole by the induced dipole. FIG. 45 depicts an embodiment in which a current is directly excited in the conducting loop. The current in the loop can substantially cancel the far-field radiation from the dipole of the resonator system. The magnetic dipole magnitude is the product of three factors: the current, the number of turns in the loop, and the effective area of the loop. In embodiments, the effective area of the outer loop is substantially larger than the effective area of the resonator system. This allows use of an excitation current in the outer loop that is substantially less than the currents flowing in the resonator system.

[0298] FIG. 46 depicts an embodiment a two or more conductors are configured as short monopole antennas that are capacitively loaded at their tops. Each individual conductor is similar to a so-called top-hat antenna. With sufficient capacitive loading at the top, currents of opposite phase can be induced in the two conductors by the magnetic-dipole field of the resonator system. These induced currents create a dipole field that can partially cancel the far-field radiation from the dipole of the resonator system. FIG. 47 depicts an embodiment in which currents of opposite direction are directly excited in the two conductors. These opposing

currents can create a dipole field that can substantially cancel the far-field radiation from the resonators.

[0299] In some embodiments, two or more resonators are exchanging wireless energy in a configuration where larger conducting objects are located above and below the resonators. Two or more conductors can be placed outside of the resonators in a way that the conductors are electrically connected to one object and capacitively coupled to the second object as shown in FIG. 48. In embodiments, a stiff wire with a conducting plate on top would enhance the capacitive coupling to the second object. In embodiments, two or more top-hat antennas would couple capacitively to the second object. In embodiments, brushes or alignment aids or conducting posts could be configured to act as capacitively-coupled conductors. The currents induced in the outer conductors can partially cancel the far-field dipole radiation of the resonator system. FIG. 49 depicts an embodiment in which currents of opposite sign are excited in the two antennas. These opposing currents can create a dipole field that can substantially cancel the far-field radiation from the resonators.

[0300] In the embodiments discussed above, the goal is to eliminate or reduce the dipole contribution to the field far from a wireless power system. There exists a natural measure (figure of merit) to establish to what extent has the dipole term been successfully suppressed. A magnetic resonator has a characteristic area A . Typically, such a resonator will have magnetic dipole moment far from the resonator proportional to IA , where I is the current flowing in the resonator. If one measures the field far from the system and concludes that the field has magnetic dipole moment $\ll IA$, that means that the scheme we propose has been implemented successfully.

[0301] It is to be understood that the techniques and embodiments described may be used with any number of

different resonator types and configurations. Although many figures and embodiment examples were described and shown with a capacitively loaded loop resonator other resonator types may also be used in the embodiments. For example, planar resonators comprising a block of magnetic material such as shown in FIG. 2D or 2E may be used. The techniques may be used with resonator coil comprising solid conducting wire, Litz wire, or printed conductor traces that may be etched on a printed circuit board.

[0302] While the invention has been described in connection with certain preferred embodiments, other embodiments will be understood by one of ordinary skill in the art and are intended to fall within the scope of this disclosure, which is to be interpreted in the broadest sense allowable by law. For example, designs, methods, configurations of components, etc. related to transmitting wireless power have been described above along with various specific applications and examples thereof. Those skilled in the art will appreciate where the designs, components, configurations or components described herein can be used in combination, or interchangeably, and that the above description does not limit such interchangeability or combination of components to only that which is described herein.

[0303] All documents referenced herein are hereby incorporated by reference.

1. A magnetic resonator comprising:

an inductor comprising a conductive first loop having a first dipole moment and a conductive second loop having a second dipole moment wherein a direction of the first dipole moment is substantially opposite to a direction of the second dipole moment; and
at least one capacitor in series with at least one of the first loop and the second loop.

2-20. (canceled)

* * * * *