

(19) World Intellectual Property Organization
International Bureau



(43) International Publication Date
7 May 2009 (07.05.2009)

PCT

(10) International Publication Number
WO 2009/057966 A2

- (51) **International Patent Classification:**
H04B 7/04 (2006.01)
- (21) **International Application Number:**
PCT/KR2008/006425
- (22) **International Filing Date:** 30 October 2008 (30.10.2008)
- (25) **Filing Language:** Korean
- (26) **Publication Language:** English
- (30) **Priority Data:**
10-2007-0109467 30 October 2007 (30.10.2007) KR
- (71) **Applicant (for all designated States except US):** POS-DATA CO., LTD. [KR/KR]; 276-2, Seohyeon-dong, Bundang-gu, Seongnam-si, Gyeonggi-do 463-775 (KR).
- (72) **Inventors; and**
- (75) **Inventors/Applicants (for US only):** LI, Zheng Zi [CN/KR]; 1th Fl., 6402, Taepyeong 1-dong, Sujeong-gu, Seongnam-si, Gyeonggi-do 461-823 (KR). KIM, San-Hae [KR/KR]; 210-1306, Hyundai I-Park 1-Cha Apt., Bo-jeong-dong, Giheung-gu, Yongin-si, Gyeonggi-do 446-567

- (KR). LEE, Dong-Jun [KR/KR]; 101-101, Lotte Castle Morning Apt., 551-28, Dogok 1-dong, Gangnam-gu, Seoul 135-271 (KR).
- (74) **Agent:** JU, Bong-Jin; 5th Fl., Eunseong Bldg., 601-18, Yeoksam-dong, Gangnam-gu, Seoul 135-080 (KR).
- (81) **Designated States (unless otherwise indicated, for every kind of national protection available):** AE, AG, AL, AM, AO, AT, AU, AZ, BA, BB, BG, BH, BR, BW, BY, BZ, CA, CH, CN, CO, CR, CU, CZ, DE, DK, DM, DO, DZ, EC, EE, EG, ES, FI, GB, GD, GE, GH, GM, GT, HN, HR, HU, ID, IL, IN, IS, JP, KE, KG, KM, KN, KP, KZ, LA, LC, LK, LR, LS, LT, LU, LY, MA, MD, ME, MG, MK, MN, MW, MX, MY, MZ, NA, NG, NI, NO, NZ, OM, PG, PH, PL, PT, RO, RS, RU, SC, SD, SE, SG, SK, SL, SM, ST, SV, SY, TJ, TM, TN, TR, TT, TZ, UA, UG, US, UZ, VC, VN, ZA, ZM, ZW.
- (84) **Designated States (unless otherwise indicated, for every kind of regional protection available):** ARIPO (BW, GH, GM, KE, LS, MW, MZ, NA, SD, SL, SZ, TZ, UG, ZM, ZW), Eurasian (AM, AZ, BY, KG, KZ, MD, RU, TJ, TM), European (AT, BE, BG, CH, CY, CZ, DE, DK, EE, ES, FI,

[Continued on next page]

(54) **Title:** METHOD AND APPARATUS FOR SUPPORTING COLLABORATE MIMO IN WIRELESS COMMUNICATION SYSTEM

[Fig. 6]

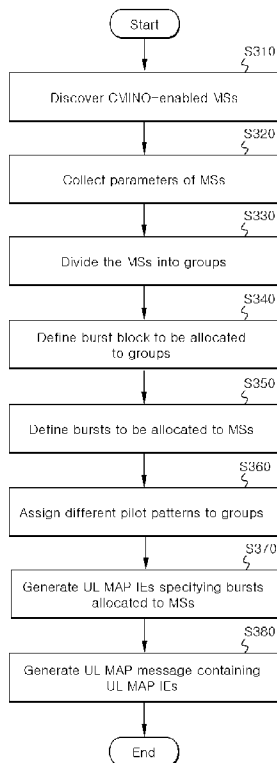

(57) **Abstract:** A method and system for supporting Collaborative Multiple-Input Multiple- Output (CMIMO) is provided for improving system throughput without compromising hardware complexity. The method for supporting collaborative multiple-input multiple-output system according to the present invention includes grouping a plurality of CMIMO mobile stations into at least two groups determining a identical size and position of a burst region to be independently allocated to the at least two groups in uplink burst zone; allocating bursts to the mobile stations included in each group in the burst region; and generating uplink MAP information elements based on information of burst allocation for the CMIMO mobile stations, recoding an uplink MAP message using the uplink MAP information elements, and transmitting the uplink MAP message to the CMIMO mobile stations. The method and apparatus for supporting CMIMO according to the present invention allows forming a group of an odd number of mobile stations increases freedom of resource allocation, resulting in improvement of resource utilization efficiency and system throughput.

WO 2009/057966 A2



FR, GB, GR, HR, HU, IE, IS, IT, LT, LU, LV, MC, MT, NL,
NO, PL, PT, RO, SE, SI, SK, TR), OAPI (BF, BJ, CF, CG,
CI, CM, GA, GN, GQ, GW, ML, MR, NE, SN, TD, TG).

Published:

— *without international search report and to be republished
upon receipt of that report*

Description

Method and apparatus for supporting collaborate MIMO in wireless communication system

Technical Field

- [1] The present invention relates to a wireless communication system and, in particular, to a method and apparatus for supporting Collaborative Multiple-Input Multiple-Output (CMIMO) in a wireless communication system that is capable of grouping mobile stations and allocating resources to the grouped mobile stations.

Background Art

- [2] With the increasing requirements for high-data rate mobile communication, various wireless technologies have been developed for supporting broadband portable Internet access services. Multiple-Input Multiple-Output (MIMO) is one of the key technologies for the portable Internet connections in mobile environment.
- [3] FIGs. 1 and 2 show a conventional Single-Input Single-Output (SISO) antenna system and a conventional MIMO antenna system, respectively.
- [4] A SISO system consists of a transmitter having one transmit antenna (TxAnt) and a receiver having one receive antenna (RxAnt). As shown in an exemplary SISO-based wireless communication system of FIG. 1, a mobile station (MS) having a single transmit antenna (TxAnt) sends a signal to a base station (BS) having a single receive antenna (RxAnt) through an uplink channel (H) established between the transmit antenna (TxAnt) and the receive antenna (RxAnt). However, the SISO system is vulnerable to multipath channel fading effect caused by geographical obstacles such as hills, valleys, and steel towers, thereby increasing errors and degrading data rate. Accordingly, the SISO system is not appropriate for the broadband digital communication services such as portable Internet Access.
- [5] In the meantime, a MIMO system uses multiple antennas at both the transmitter and receiver such that the transmitter can improve transmission efficiency by exploiting spatial and temporal diversities and spatial multiplexing and the receiver reduce inter-channel interferences by recovering the transmission signals from respective channels. As shown in an exemplary 2 x 2 MIMO-based wireless communication system of FIG. 2, a mobile station (MS) has two transmit antennas (TxAnt0 and TxAnt1), and a base station (BS) has two receive antennas (RxAnt0 and RxAnt1) such that the mobile station can transmit signals to the base station through up to four channels, i.e. H00, H01, H10, and H11. Since the MIMO system allows transmitting signals through multiple channels established between multiple transmit and receive antennas, its channel capacity increases significantly in comparison with the SISO system. In rich

multipath environment, the MIMO system also allows the transmitter to send a signal through multiple orthogonal channels, in parallel, in the same frequency bandwidth so as to accomplish high spectrum efficiency in comparison with the SISO system.

- [6] In a case of 2 x 2 MIMO system, however, the mobile station requires multiple transmit antennas for uplink transmission, thereby increasing power consumption and hardware complexity. Accordingly, there has been a need to develop an enhanced Collaborative MIMO (CMIMO) technique that is capable of accomplishing the transmission throughput of the conventional MIMO system with a single transmit antenna at the mobile station without increasing hardware complexity.

Disclosure of Invention

Technical Problem

- [7] In order to overcome the above problems of the prior art, the present invention provides a method and apparatus for supporting CMIMO in a wireless communication system.
- [8] Also, the present invention provides a method and apparatus for supporting CMIMO in a wireless communication system that is capable of reducing scheduling complexity.
- [9] Also, the present invention provides a method and apparatus for supporting CMIMO in a wireless communication system that is capable of pairing mobile stations optimally and scheduling the paired stations efficiently.

Technical Solution

- [10] In accordance with an exemplary embodiment of the present invention, there is provided a method for supporting CMIMO (Collaborative Multiple-Input Multiple-Output) in a wireless communication system. The method includes making a plurality of CMIMO MS(mobile station) groups from a plurality of mobile stations; determining burst size and burst allocation region of each CMIMO MS group of the plurality of CMIMO MS groups in uplink burst region to be equal each other; allocating burst of each CMIMO mobile station of the CMIMO MS group within the determined burst allocation region of the CMIMO MS group; and Configuring uplink MAP information based on determination of burst allocation information, generating uplink MAP message using the uplink MAP information and transmitting to CMIMO mobile stations of the CMIMO MS group.
- [11] In accordance with another exemplary embodiment of the present invention, there is provided a method for supporting CMIMO (Collaborative Multiple-Input Multiple-Output) in a wireless communication system. The method includes generating and transmitting the uplink MAP message to CMIMO mobile stations so that the CMIMO mobile stations included in a first and a second group are each allocated burst in a burst regions which are identical size and position of burst regions to the first group and the

second group; and receiving data burst which is allocated in the burst regions based on the uplink MAP message from at least one of the CMIMO mobile stations.

[12] In accordance with another exemplary embodiment of the present invention, there is provided a method for supporting collaborative multiple-input multiple-output in a wireless communication system. The method includes receiving each registration request messages including information of mobile station from a plurality of mobile stations; and generating and transmitting an uplink MAP message in order to use identical uplink burst region by CMIMO mobile station groups which is grouped from CMIMO mobile stations selected according to the information of mobile station.

[13] In accordance with another exemplary embodiment of the present invention, there is an apparatus for supporting collaborative multiple-input multiple-output in a wireless communication system. The apparatus includes a scheduler for allocating identical size and position of a burst region to a first and second groups including CMIMO mobile stations independently in uplink burst zone, and generating an uplink MAP message to allocate bursts to each of the CMIMO mobile stations included in the first and second groups; and a transmitter for transmitting the uplink MAP message to the CMIMO mobile stations.

[14] In accordance with another exemplary embodiment of the present invention, there is provided a method for supporting collaborative multiple-input multiple-output in a wireless communication system. The method includes Receiving from a base station an uplink MAP message including allocation information to allocate each burst of CMIMO mobile stations so that each group has identical size and position of burst region for two CMIMO mobile station groups each including at least two CMIMO mobile stations from a base station; and transmitting a data burst including pilots based on the uplink MAP message to the base station, wherein the uplink MAP message further includes a pilot pattern information indicating type of pilot patterns for the CMIMO mobile stations.

Advantageous Effects

[15] The method and apparatus for supporting CMIMO according to the present invention groups MSs into at least two groups (layers) and allows pairing a single MS belonged to one group with multiple MSs belonged to the other, resulting in simplification of pairing algorithm and service to odd number of MSs.

[16] Also, the method and apparatus for supporting CMIMO according to the present invention enables allocating the same UL resource to the MSs belonged to different groups independently, thereby increasing freedom of resource allocation of the system, resulting in improvement of resource utilization efficiency and system throughput.

Brief Description of Drawings

- [17] The above and other aspects, features and advantages of the present invention will become more apparent from the following detailed description when taken in conjunction with the accompanying drawings in which:
- [18] FIG. 1 is a schematic diagram illustrating a conventional SISO system;
- [19] FIG. 2 is a schematic diagram illustrating a conventional MIMO system;
- [20] FIG. 3 is a diagram illustrating an uplink CMIMO system according to an exemplary embodiment of the present invention;
- [21] FIG. 4 is a diagram illustrating an Orthogonal Frequency Division Multiple Access (OFDMA) frame structure for use in a wireless communication system according to an exemplary embodiment of the present invention;
- [22] FIG. 5 is a message flow diagram illustrating a method for supporting CMIMO in a wireless system according to an exemplary embodiment of the present invention;
- [23] FIG. 6 is a flowchart illustrating a scheduling procedure in a wireless system;
- [24] FIG. 7 is a diagram illustrating an OFDMA frame structure for use in an uplink CMIMO system according to an exemplary embodiment of the present invention;
- [25] FIG. 8 is a diagram illustrating the UL burst 2 of FIG. 7 which is allocated to MSs of a first group according to an exemplary embodiment of the present invention;
- [26] FIG. 9 is a diagram illustrating the UL burst 2 of FIG. 8 which is allocated to MSs of a second group;
- [27] FIG. 10 is a diagram illustrating the UL burst 2 of FIG. 7 which is allocated to MSs of a first group according to another exemplary embodiment of the present invention;
- [28] FIG. 11 is a diagram illustrating the UL burst 2 of FIG. 10 which is allocated to MSs of a second group;
- [29] FIG. 12 is a diagram illustrating a HARQ subburst allocation procedure in an OFDMA frame according to an exemplary embodiment of the present invention;
- [30] FIG. 13 is a block diagram illustrating a configuration of a base station supporting CMIMO-mode resource allocation according to an exemplary embodiment of the present invention; and
- [31] FIG. 14 is a block diagram illustrating a configuration of the scheduler of FIG. 13.

Mode for the Invention

- [32] Exemplary embodiments of the present invention are described with reference to the accompanying drawings in detail. The same reference numbers are used throughout the drawings to refer to the same or like parts. Detailed descriptions of well-known functions and structures incorporated herein may be omitted to avoid obscuring the subject matter of the present invention.
- [33] Although the method and apparatus for supporting CMIMO according to the present invention is described with an exemplary 2 x 2 uplink CMIMO system composed of

two mobile stations each having a single transmit antenna and one base station having two receive antennas for simplifying the explanation in the following description, the present invention is not limited thereto. For example, the method and apparatus for supporting CMIMO according to the present invention can be applied to various types of MIMO system such as 4 x 4 CMIMO systems.

[34] FIG. 3 is a diagram illustrating an uplink CMIMO system according to an exemplary embodiment of the present invention.

[35] As shown in FIG. 3, the uplink CMIMO system consists of a base station (BS) having two receive antennas (RxAnt0 and RxAnt1) and two mobile stations each having a single transmit antenna. Here, the first and second CMIMO mobile stations transmit their signals through respective antennas (TxAnt0 for the first CMIMO mobile station and TxAnt1 for the second mobile station) with different pilot patterns. In this 2 x 2 MIMO configuration, a signal transmitted from the first transmit antenna TxAnt0 of the first CMIMO mobile station reaches the receive antennas RxAnt0 and RxAnt1 through the first and second channels H00 and H01 and a signal transmitted from the second transmit antenna TxAnt1 of the second CMIMO mobile station reaches the receive antennas RxAnt0 and RxAnt1 through the third and fourth channels H10 and H11. At this time, the first and second CMIMO mobile stations transmit the signals in the same subcarrier (or sub-channel) with different pilot patterns such that the base station receives the spatially multiplexed signals through the first and second receive antennas RxAnt0 and RxAnt1 and recovers the signals through a spatial de-multiplexing process.

[36] FIG. 4 is a diagram illustrating an Orthogonal Frequency Division Multiple Access (OFDMA) frame structure for use in a wireless communication system according to an exemplary embodiment of the present invention.

[37] Referring to FIG. 4, an OFDMA frame consists of a downlink (DL) subframe and an uplink (UL) subframe. The DL subframe starts with a Preamble followed by a Frame Control Header (FCH), a DL MAP, a UL MAP, and DL Bursts. The UL subframe starts with a control symbol period (carrying Ranging channels, Channel Quality Indicator (CQI) channels, and Acknowledgement channels (ACK)) followed by UL Bursts. Here, the DL subframe can include Hybrid Automatic Repeat-Request (HARQ) MAPs and HARQ bursts, selectively. Also, the information on the HARQ bursts can be inserted into the DL and UL MAPs. In such frame structure, the DL subframe may include at least one of the Preamble period, Partial Usage of Subchannels (PUSC) subchannel period, Adaptive Modulation and Coding (AMC) subchannel period; and the DL subframe may include at least one of UL control period, PUSC subchannel period, and AMC subchannel period.

[38] The Preamble contains time and frequency synchronization information and cell in-

formation. The FCH contains frame information and DL MAP decoding information. The DL MAP specifies the types of the DL bursts (i.e. SISO type or MIMO type), station IDs for identifying mobile stations allocated the DL bursts, and offsets for indicating burst regions in the frame. The UL MAP defines the access to UL resource, i.e. the UL Bursts allocated for the mobile stations.

- [39] In this embodiment, the base station specifies the UL burst allocation information in the UL MAP by means of UL MAP Information Elements (IEs). The mobile station received the frame first decodes the UL MAP and transmits its data to the base stations through the resources defined by sizes and positions of the UL burst allocation information.
- [40] A method for supporting CMIMO in a wireless system is described hereinafter with reference to accompanying drawings.
- [41] FIG. 5 is a message flow diagram illustrating a method for supporting CMIMO in wireless communication system according to an exemplary embodiment of the present invention. In this embodiment, it is a method for supporting CMIMO in base station (BS) and mobile stations (MSs).
- [42] Referring to FIG. 5, each MS sends an MS Basic Capability Request (SBC-REQ) message carrying its capability to the BS, and the BS sends an MS Basic Capability Response (SBC-RSP) message carrying the basic capability available between the BS and each MS to the BS in response to the SBC-REQ at step S100.
- [43] After completing the capacity negotiation, each MS sends a Registration Request (REG-REQ) message to the BS, and the BS sends a Registration Response (REG-RSP) message to the MS such that the MS is registered with the BS at step S200. In the registration procedure, each MS sends a secondary management Connection Identifier (CID) to the BS such that the BS registers the MS as a manageable SS. The REG-REQ message contains the secondary management CID, and the REG-RSP message contains authentication information with which the MS can transmit traffic through the communication network.
- [44] Next, the BS performs scheduling of the MSs at step S300. In the scheduling procedure, the BS groups the MSs into two groups, pairs the MSs of one group with the MSs of the other group, and allocates resources to the paired MSs. The resource allocation is a process creating UL MAP IEs specifying positions and sizes of the bursts to the respective MSs in the UL frame and assigning pilot patterns to the MSs. Particularly in this embodiment, a number of groups is fixed, and a number of MSs constituting each group is changeable. The size and position of a burst region given for groups are identical with each other, and the positions and sizes of the bursts to be allocated to the MSs belonged to the same group are determined in the given burst region of the group in consideration of parameters such as channel qualities, channel

loss caused by mobility, power allocations to the MSs, and correlations between MSs. The scheduling procedure is described in more detail later.

[45] Next, the BS transmits a UL MAP carrying the resource allocation information (including, positions and sizes of bursts and pilot patterns assigned to the respective MSs) according to the schedule at step S400.

[46] Each MS received the OFDMA frame decodes the UL MAP (S500) and transmits the data reserved for the bursts indicated by the UL MAP (S600). At this time, the MSs belonged to the different groups send their data with different pilots.

[47] FIG. 6 is a flowchart illustrating a scheduling procedure of the method of FIG. 5.

[48] Referring to FIG. 6, a BS discovers CMIMO-enabled MSs (CMIMO MSs) in a communication environment in which SISO and MIMO systems are coexisting with reference to basic capacities received from the CMIMO MSs at step S310.

[49] Next, the BS collects parameters associated with the CMIMO MSs at step S320. The parameters include channel qualities, channel loss caused by mobility, power allocations to the CMIMO MSs, and correlations between CMIMO MSs.

[50] Next, the BS groups the CMIMO MSs into two groups on the basis of at least one or a combination of the parameters at step S330. For example, the CMIMO MSs are grouped into two groups (CMIMO MS groups) on the basis of at least one of channel loss information, Carrier to Interference-plus-Noise (CINR) information, power allocation information, correlation level between ranging channels, correlation level between sounding channels, or correlation level between pilot channels. Of course, at least two of these parameters can be used for grouping the CMIMO MSs. Particularly when using the CINR, the CMIMO MSs can be grouped into two groups sequentially in an ascending order of CINR values. Also, the CMIMO MSs can be grouped randomly regardless of the parameters.

[51] After determination of two groups, the BS determines the position and size of the UL burst region to be allocated to the groups at step 340. At this time, the BS determines the position and size of the UL burst region on the basis of the channel qualities between the BS and CMIMO MSs, e.g. Quality of Service (QoS), the positions and sizes of the UL burst region of the two groups being identical with each other. The UL burst region definition procedure is described hereinafter in more detail with reference to FIG. 7.

[52] FIG. 7 is a diagram illustrating an OFDMA frame structure for use in an uplink CMIMO system according to an exemplary embodiment of the present invention.

[53] As shown in FIG. 7, the OFDMA frame includes a DL subframe starting with a Preamble, a FCH, a DL MAP, a UL MAP, and DL Bursts; and a UL subframe starting with a Ranging channel followed by a CQI channel, an ACK channel, and UL Bursts. Here, the UL MAP defines the access to UL resource, i.e. the UL Bursts allocated to

MSs.

[54] In FIG. 7, the UL burst zone consists of UL burst 1, UL burst 2, , UL burst N. In this embodiment, the BS determines a position and size of the UL burst region to be allocated to the first and second groups from a UL burst region (UL burst 1, UL burst 2, , UL burst K) for CMIMO. In this embodiment, it is assumed that the position and size of the UL burst region is determined to be corresponding to the UL burst 2 in FIG. 7, and the UL burst 2 is in UL PUSC mode.

[55] Returning to FIG. 6, after defining the position and size of the UL burst region, the BS determines positions and sizes of the bursts to be allocated to respective MSs at step S350. As in the example of FIG. 7, the UL burst 2 determined as the UL burst region to be allocated to the CMIMO-enable MSs of the first and second groups, the UL burst 2 can be divided into identical size bursts, as shown in FIGS. 8 and 9, to be fairly allocated to the MSs of each group or different size bursts, as shown in FIGS. 10 and 11, to be allocated to the MSs of each group differentially according to the channel qualities.

[56] The burst size determination process is described hereinafter in more detail.

[57] FIGS. 8 and 9 are diagrams illustrating the UL burst 2 of FIG. 7 that are allocated to the mobile stations of the first and second groups.

[58] The UL burst 2 is divided into 36 slots, and the BS allocates the same number of slots to the MSs of each group as shown in FIGS. 8 and 9, or allocates different numbers of slots to the MSs of each group according to the channel qualities of the MSs as shown in FIGS. 10 and 11. Here, a slot consists of 6 tiles. The tile is a basic unit constituting the PUSC subchannel and consists of 3 OFDMA symbol x 4 subcarriers on the 2 dimensional OFDMA symbol subcarrier plane.

[59] In FIG. 8, the BS divides the UL burst region (UL burst 2 in FIG. 7) into three bursts, each consisting of 12 slots, and assigns the three bursts to the three MSs a1, a2, and a3 of the first group, respectively. Also, the BS divides the UL burst region into 4 bursts, each consisting of 9 slots, and assigns the 4 bursts to the four MSs b1, b2, b3, and b4 of the second group, respectively (see FIG. 9).

[60] In this case, the BS performs scheduling such that the MS a1 of the first group is paired with the MS b1 of the second group to 9 slots and with the MS b2 to 3 slots. Next, the BS performs scheduling such that the MS a2 is paired with the MS b2 to 6 slots and with the MS b3 to 6 slots. Finally, the BS performs scheduling such that the MS a3 is paired with the MS b3 to 3 slots and with the MS b4 to 9 slots. The burst allocation information of CMIMO-paired MSs is specified in a MIMO UL Basic IE and transmitted to the MSs through a UL MAP message.

[61] Meanwhile, in FIG. 10, the UL burst region (UL burst 2 in FIG. 7) is divided into three different sizes of bursts to be allocated to three MSs a1, a2, and a3 of a first

group. Here, the sizes of the bursts are determined on the basis of the channel qualities to the BS in a given size of the UL burst region. In this exemplary embodiment, the MS a1 which has best channel quality among the three MSs a1, a2, and a3 of the first group is allocated the burst composed of 14 slots; the MS a2 which has a moderate channel quality is allocated the burst composed of 13 slots; and the MS a3 which has bad channel quality is allocated the burst composed of 9 slots.

[62] In FIG. 11, the UL burst region (UL burst 2 in FIG. 7) is divided into four different sizes of bursts to be allocated to the MSs b1, b2, b3, and b4 of a second group. Here, the sizes of the bursts are determined on the basis of channel qualities of the MSs to the BS in a given size of the UL burst region. In this case, the MS b1 which has the best channel quality among the four MSs b1, b2, b3, and b4 of the second group is allocated the burst composed of 13 slots; the MS b2 which has the next higher channel is allocated the burst composed of 10 slots; the MS b3 is allocated the burst composed of 7 slots; and the MS b4 is allocated the burst composed of 6 slots.

[63] The BS performs scheduling such that the MS a1 of the first group is paired with the MS b1 of the second group to 13 slots and with the MS b2 to 1 slot; the MS a2 is paired with the MS b2 to 9 slots and with the MS b3 to 4 slots; and the MS a3 is paired with the MS b3 to 3 slots and with the MS b4 to 6 slots. As described above, the burst allocation information CMIMO-paired MSs is specified in the MIMO UL Basic IE and transmitted to the MSs through the UL MAP message.

[64] Returning to FIG. 6, after determination of the positions and sizes of the bursts, the BS assigns pilot patterns to the groups. Here, the two MS groups are assigned different pilot patterns. By assigning different pilot patterns to the two groups of CMIMO MSs, it is possible to minimize the increase of MAP size. Unlike this pilot pattern assignment, all the CMIMO MSs belonged to the first and second groups can be assigned different pilot patterns. In this case, the CMIMO MSs sharing the same burst have to be assigned different pilot patterns.

[65] After assigning pilot patterns, the BS creates UL MAP Information Elements (IEs) specifying the resources allocated to respective CMIMO MSs of the first and second groups at step S370, and generates a UL MAP message containing the UL MAP IEs at step 380. Finally, the UL MAP message is transmitted to the CMIMO MSs.

[66] FIG. 12 is a diagram illustrating a HARQ subburst allocation procedure in an OFDMA frame according to an exemplary embodiment of the present invention. In this embodiment, it is assumed that the UL burst 2 is reserved for the HARQ subbursts.

[67] In this embodiment, the BS uses UL MAP IE, Extended-2 UIUC dependent IE, HARQ UL MAP IE, UL HARQ Chase Subburst IE, and Dedicated UL control IE, for allocating UL resource (HARQ subbursts) to CMIMO MSs. These Information Elements are exemplarily shown in tables 1 to 5.

[68] [Table 1]

[69]

```

UL MAP IE {
  CID
  UIUC
  If(UIUC==11){
    Extended UIUC 2 dependent IE
  } else if(UIUC==12) {
    —
  } else if (UIUC == 13) {
    —
  } else if (UIUC == 14) {
    —
  } else if (UIUC == 15) {
    —
  } else if (UIUC == 0) {
    —
  } else {
    —
  }
}

```

[70] The UL MAP IE defines UL bandwidth allocations. UL bandwidth allocations are specified either as block allocations with an absolute offset or as an allocation with duration in slots with either a relative or absolute slot offset. In an exemplary UL MAP IE of table 1, the UL Interval Usage Code (UIUC) defines UL access type and burst type associated with the UL access type. For example, the block allocations are used for fast feedback (UIUC=0), CDMA ranging and bandwidth request allocations (UIUC=12), as well as PAPR/Safety zone allocations (UIUC=13). In the meantime, CDMA allocation (UIUC=14) is used for bandwidth allocation to the subscribed CMIMO MS that requests bandwidth with a CDMA request code and a case of indicating that the current IE contains special information (UIUC=11, UIUC=15). When the UIUC of the UL MAP IE is set to 11 as shown in table 1, the UL MAP IE contains an Extended-2 UIUC dependent IE carrying specific information (see table 2).

[71] [Table 2]

[72]

```

Extended-2 UIUC dependent IE
{
0x06 HARQ UL MAP IE
}

```

[73] The Extended-2 UIUC dependent IE contains an HARQ UL MAP IE formatted as shown in table 3.

[74] [Table 3]

[75] **HARQ UL MAP IE**

```

{
  Mode [0b000 – Chase HARQ, 0b011 – MIMO Chase HARQ]
  N sub Burst [Indicates the number of bursts in this UL MAP IE]
  For (i =0 ;i < N Sub-burst; i++)
  {
    If (Mode == 000)
    {
      UL HARQ Chase Sub-Burst IE ()
    }
  }
}

```

[76] The HARQ UL MAP IE is used to indicate available modes and non-HARQ transmission and defines at least one HARQ subbursts. Referring to table 3, the HARQ UL MAP IE includes a Mode field for indicating available HARQ modes. The value 0b000 indicates Chase HARQ mode and 0b011 indicates MIMO Chase HARQ mode in the Mode field. Particularly in this embodiment, the Chase HARQ mode is exemplarily used. The HARQ UL MAP IE also includes a N sub Burst field for indicating a number of HARQ subbursts in the UL MAP IE. The number of HARQ subbursts is defined using for command format which contains UL HARQ Chase Subburst IE formatted as shown in table 4.

[77] [Table 4]

[78] **UL HARQ Chase Sub-Burst IE**

```

{
  Dedicated UL Control Indicator
  If (Dedicated UL Control Indicator ==1)
  {
    Dedicated UL Control IE ()
  }
  UIUC
  Duration
  ACK disable
}

```

[79] The UL HARQ Chase Subburst IE specifies details on the chase combining of the HARQ Subbursts for the CMIMO MS in the HARQ mode specified in the HARQ UL MAP IE. Referring to the exemplary UL HARQ Chase Subburst IE of table 4, the UL HARQ Chase Subburst IE created by the BS includes Dedicated UL Control Indicator

field. The Dedicated UL Control Indicator is set to 1 for indicating that the current IE contains the new HARQ Subburst allocation information, or set to 0 for indicating that the HARQ Subburst allocation information is identical with the previous HARQ Subburst allocation information. Accordingly, when the BS sets the Dedicated UL Control Indicator to 1 in the UL HARQ Chase Subburst IE, the UL HARQ Chase Subburst IE contains Dedicated UL Control IE which specifies the HARQ Subburst allocation information in detail as shown in table 5. In this embodiment, the Dedicated UL control IE specifies a number of groups (or number of layers) and pilot patterns assigned to the respective groups (see table 5). In the meantime, the UIUC field of the UL HARQ Chase Subburst IE in table 4 is used to define UL access type and burst type associated with the UL access type, the duration field is used for defining allocation period in unit of OFDMA slot, and ACK Disable field is used to indicate that the BS acknowledge. If the BS has set the ACK Disable field to 1, the BS does not acknowledge receipt of the HARQ subburst transmitted by the CMIMO MS, and the CMIMO MS does not need to retransmit the HARQ subburst.

[80] [Table 5]

[81]

Dedicated UL Control IE	
{	
	Control header [Bit #0: SDMA Control Info Bit #1-3: Reserved]
	If (SDMA Control Info Bit == 1)
	{
	Num SDMA layers
	Pilot pattern [0b00 – pattern A, 0b01 – pattern B, 0b10 – pattern C, 0b11 – pattern D]
	}
}	

[82] The BS sends additional control information on each HARQ subburst to the CMIMO MS using the Dedicated UL Control IE. In table 5, the Num SDMA layers field indicates a number of groups (or, layers) and the Pilot pattern field indicates pilot patterns assigned to respective groups.

[83] FIG. 12 shows how the Information Elements exemplarily shown in tables 1 to 5 are assigned to the UL subframe.

[84] Referring to FIG. 12, the UL MAP of the OFDMA frame specifies the HARQ subburst allocation information for respective CMIMO MSs (having unique CIDs) belonged to the first and second groups with the HARQ UL MAP IE. The UL HARQ Chase Subburst IE 371 indicates transmission types of the HARQ subbursts of the CMIMO MSs. Here, the group-based CMIMO mode is indicated by the SDMA Control Info bit contained in the Dedicated UL Control IE (see table 5). In this

embodiment, the UL HARQ Chase Subburst IEs 371 and 373 contain the SDMA Control Info bit, but UL HARQ Chase Subburst IEs 372 and 374 do not contain the SDMA Control Info bit.

- [85] Although the UL MAP is described with the Information Elements formatted as shown in tables 1 to 5, the present invention is not limited thereto. For example, the method and apparatus for supporting CMIMO according to the present invention can be accomplished by modifying a set of UL MAP IE, Extended UIUC 2 dependent IE, and MIMO UL Basic IE, or a set of UL MAP IE, Extended 2 UIUC IE, and MIMO UL Chase HARQ sub-burst IE; and creating the UL MAP IEs using the burst allocation information on the respective CMIMO MSs determined at steps S340 and 360.
- [86] In this manner, although the burst sizes of the CMIMO MSs are different from each other, the BS can discover appropriate CMIMO partners and pair the CMIMO MSs without padding or cutting the data, resulting in reduction of resource waste and scheduling complexity.
- [87] A structure of the BS for supporting Method for supporting CMIMO according to the present invention is described hereinafter. Detailed descriptions of structures and functions that are already explained with reference to any of FIGs. 3 to 12 are omitted.
- [88] FIG. 13 is a block diagram illustrating a configuration of a base station supporting CMIMO-mode resource allocation according to an exemplary embodiment of the present invention.
- [89] Referring to FIG. 13, the base station (BS) includes an interface 100, a signal processor 200, a transmitter 300, a receiver 600, a scheduler 500, and an antenna array 400. The BS operates in Time Division Duplexing (TDD) mode such that the reception and transmission channels are separated in time.
- [90] In uplink channel, the receiver 600 receives radio signals transmitted by at least one CMIMO-enable mobile station (MS) through the antenna array 400 and down-converts the radio signals to baseband signals. For example, the receiver 600 reduces noise and amplifying the received radio signal, down-converts the low noise amplified radio signal to a baseband signal, and converts the baseband signal to a digital signal. The signal processor 200 extracts information or data bits and performs demodulation, decoding, and error correction on the information. The information is then transmitted to adjacent wired/wireless network or another CMIMO-enable MS serviced by the BS via the interface 100.
- [91] In downlink channel, the signal processor 200 encodes voice, data, or control information received from a base station controller (BSC) or another radio network through the interface 100 and outputs an encoded signal to the transmitter 300. The transmitter 300 modulates the encoded signal so as to be superimposed on a carrier signal, amplifies the carrier signal, and transmits the amplified carrier signal over the

air via the antenna array 400.

- [92] The scheduler 500 controls the operations of the downlink and uplink signal paths and internal components. Structures and functions of the scheduler 500 are described hereinafter with reference to FIG. 14 in detail.
- [93] FIG. 14 is a block diagram illustrating a configuration of the scheduler of FIG. 13. As shown in FIG. 14, the scheduler 500 includes a CMIMO searcher 510, a parameter collector 520, a CMIMO group generator 530, a burst information determiner 540, a pilot pattern allocator 550, a MAP IE generator 560, and a MAP generator 570.
- [94] The CMIMO searcher 510 searches for CMIMO-enabled MSs, in a communication environment in which SISO and MIMO mode MSs coexist, with reference to basic capacities such as physical parameters and bandwidth allocation information provided by the MSs.
- [95] The parameter collector 520 collects information on the MSs found by the CMIMO searcher 510. The CMIMO-enable MS information includes channel loss information, CINR, allocation power, CINR on CQI channel, ranging channel correlation, uplink sounding channel correlation, and pilot channel correlation.
- [96] The CMIMO group generator 530 groups the MSs into at least two groups on the basis of the information collected by the parameter collector 520, i.e. the channel loss information, CINR, allocation power, CINR on CQI channel, ranging channel correlation, uplink sounding channel correlation, and pilot channel correlation. Particularly in this embodiment, the CMIMO group generator 530 sorts the MSs in order of the CINR and forms a high CINR group and a low CINR group. In order to form the two groups, the other parameters can be used.
- [97] The burst information determiner 540 determines the position and size of a burst region to be independently allocated to the two groups. Here, the burst region is allocated to the two groups simultaneously such that the same burst region is allocated to the MSs belonged to the respective groups. The burst information determiner 540 determines the positions and sizes of the bursts to be allocated to the MSs belong to each group on the basis of the channel qualities of the MSs. Since the burst position and size determination procedure has been described already with reference to FIGs. 8 to 11, detailed description is omitted.
- [98] The pilot pattern allocator 550 allocates different pilot patterns to the respective groups or to the MSs paired with each other, i.e. the MSs allocated the same resources partially or fully.
- [99] The MAP IE generator 560 generates UL MAP IEs on the basis of the burst allocation information and pilot pattern allocation information output by the burst information determiner 540 and the pilot pattern allocator 550, and the MAP generator 570 generates an UL MAP containing the UL MAP IEs output by the MAP IE

generator 560. Since the UL MAP IE generation and UL MAP generation procedures have been described already with reference to FIG. 12, detailed description is omitted.

[100] As described above, the CMIMO mobile stations are grouped into a plurality of CMIMO MS groups (or layers) and each burst of the CMIMO Mobile stations in each CMIMO MS group is allocated based on channel quality. Accordingly, one CMIMO MS can be simultaneously paired with a plurality of CMIMO MSs and a Pairing algorithm for CMMO MSs can be simplified more than before. A Grouping for an odd number of CMIMO mobile station can be performed too.

[101] Therefore, the method and apparatus for supporting CMIMO according to the present invention can efficiently utilize radio resource and improve system throughput.

[102] Although exemplary embodiments of the present invention have been described in detail hereinabove, it should be clearly understood that many variations and/or modifications of the basic inventive concepts herein taught which may appear to those skilled in the present art will still fall within the spirit and scope of the present invention, as defined in the appended claims.

Claims

- [1] A method for supporting CMIMO (Collaborative Multiple-Input Multiple-Output) in a wireless communication system, comprising:
- (a) making a plurality of CMIMO MS(mobile station) groups from a plurality of mobile stations;
 - (b) determining burst size and burst allocation region of each CMIMO MS group of the plurality of CMIMO MS groups in uplink burst region to be equal each other;
 - (c) allocating burst of each CMIMO mobile station of the CMIMO MS group within the determined burst allocation region of the CMIMO MS group; and
 - (d) Configuring uplink MAP information based on determination of burst allocation information, generating uplink MAP message using the uplink MAP information and transmitting to CMIMO mobile stations of the CMIMO MS group.
- [2] The method of claim 1, wherein making the plurality of CMIMO MS groups in the step of (a) is based on at least one of channel quality, channel loss, Carrier to Interference-plus-Noise (CINR), allocation power, and correlation information for the CMIMO mobile stations.
- [3] The method of claim 1, wherein the step of (c) further comprising: assigning different pilot patterns with an individual group unit.
- [4] The method of claim 1, wherein in the step of (c), each CMIMO mobile station of the CMIMO MS group within the determined burst allocation region of the CMIMO MS group in the uplink burst region is assigned to different pilot patterns.
- [5] The method of claim 1, wherein the burst of each CMIMO mobile station in the step of (c) is determined based on channel qualities of the CMIMO mobile station.
- [6] A method for supporting CMIMO (Collaborative Multiple-Input Multiple-Output) in a wireless communication system, comprising:
- (a) generating and transmitting the uplink MAP message to CMIMO mobile stations so that the CMIMO mobile stations included in a first and a second group are each allocated burst in a burst regions which are identical size and position of burst regions to the first group and the second group; and
 - (b) receiving data burst which is allocated in the burst regions based on the uplink MAP message from at least one of the CMIMO mobile stations.
- [7] The method of claim 6, wherein the step of (a) determines each burst size of CMIMO mobile stations of the first and second group based on channel qualities

- of the CMIMO mobile stations.
- [8] The method of claim 6, wherein the uplink MAP includes pilot pattern type indication information assigning different pilot patterns to the first and second groups.
- [9] The method of claim 6, wherein the uplink MAP message at the step of (a) includes pilot pattern type indication information assigning different pilot patterns to the CMIMO mobile stations which is allocated identical burst in the uplink burst region.
- [10] The method for supporting CMIMO (Collaborative Multiple-Input Multiple-Output) in a wireless communication, comprising:
(a) receiving each registration request messages including information of mobile station from a plurality of mobile stations; and
(b) generating and transmitting an uplink MAP message in order to use identical uplink burst region by CMIMO mobile station groups which is grouped from CMIMO mobile stations selected according to the information of mobile station.
- [11] The method of claim 10, wherein in the step of (b), the uplink MAP message is generated in order that CMIMO mobile stations of the CMIMO mobile station group are allocated bursts to be different size, and is transmitted.
- [12] The method of claim 10, wherein in the step of (b), the uplink MAP message is generated in order that different pilot patterns are assigned to the CMIMO mobile station groups and transmitted.
- [13] The method of claim 10, wherein in the step of (b), the uplink MAP message is generated so that different pilot patterns are assigned to the CMIMO mobile stations allocated in identical burst region, and is transmitted.
- [14] An apparatus for supporting CMIMO (Collaborative Multiple-Input Multiple-Output) in a wireless communication system, comprising:
a scheduler for allocating identical size and position of a burst region to a first and second groups including CMIMO mobile stations independently in uplink burst zone, and generating an uplink MAP message to allocate bursts to each of the CMIMO mobile stations included in the first and second groups; and
a transmitter for transmitting the uplink MAP message to the CMIMO mobile stations.
- [15] The apparatus of claim 14, wherein the scheduler comprises:
a CMIMO group generator for grouping the CMIMO mobile stations into the first and second groups;
a burst information determiner for determining identically a size and a position of the burst regionallocated to the first and second groups, and allocating the bursts to the CMIMO mobile stations included the first and second groups;

a MAP information element generator for generating uplink MAP information elements using information of burst allocation which is determined by the burst information determiner for each CMIMO mobile station; and
a MAP generator for generating the uplink MAP message based on the uplink MAP information elements.

- [16] The apparatus of claim 15, wherein the CMIMO group generator groups the CMIMO mobile stations into the first and second groups based on at least one of channel quality, channel loss, Carrier to Interference-plus-Noise (CINR), allocation power, and correlation information.
- [17] The apparatus of claim 15, wherein the burst information determiner determines sizes of the bursts for the CMIMO mobile stations included the first and second groups based on channel qualities of the CMIMO mobile stations.
- [18] The apparatus of claim 15, wherein the scheduler further comprising:
a pilot pattern allocator for assigning different pilot patterns to the CMIMO mobile stations included in the first and second groups.
- [19] The apparatus of claim 15, wherein the scheduler further comprising:
a pilot pattern allocator for assigning different pilot patterns to the CMIMO mobile stations allocated in identical burst region.
- [20] A method for supporting CMIMO (Collaborative Multiple-Input Multiple-Output) in a wireless communication system, comprising:
Receiving from a base station an uplink MAP message including allocation information to allocate each burst of CMIMO mobile stations so that each group has identical size and position of burst region for two CMIMO mobile station groups each including at least two CMIMO mobile stations from a base station;
and
transmitting a data burst including pilots based on the uplink MAP message to the base station,
wherein the uplink MAP message further includes a pilot pattern information indicating type of pilot patterns for the CMIMO mobile stations.
- [21] The method of claim 20, wherein the two CMIMO mobile station groups are grouped according to at least one of channel quality, channel loss, Carrier to Interference-plus-Noise (CINR), allocation power, and correlation information.

[Fig. 1]

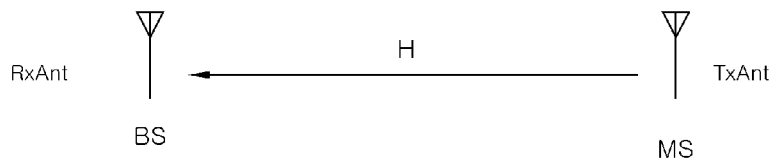

[Fig. 2]

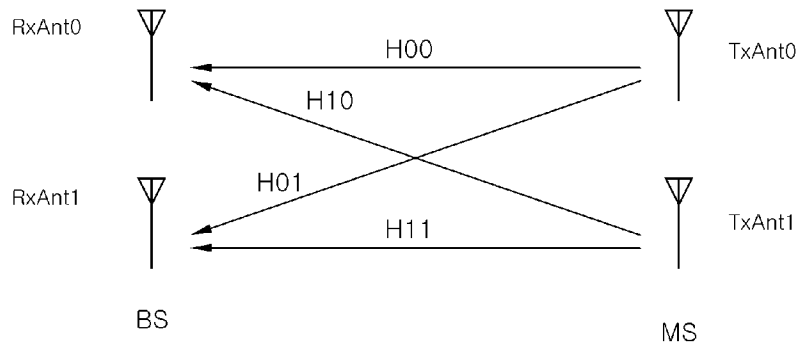

[Fig. 3]

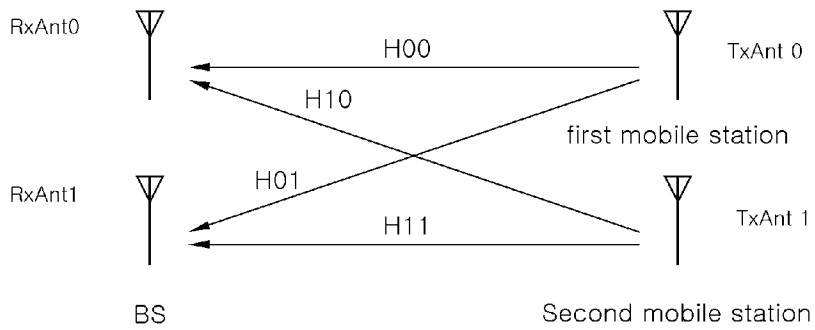

[Fig. 4]

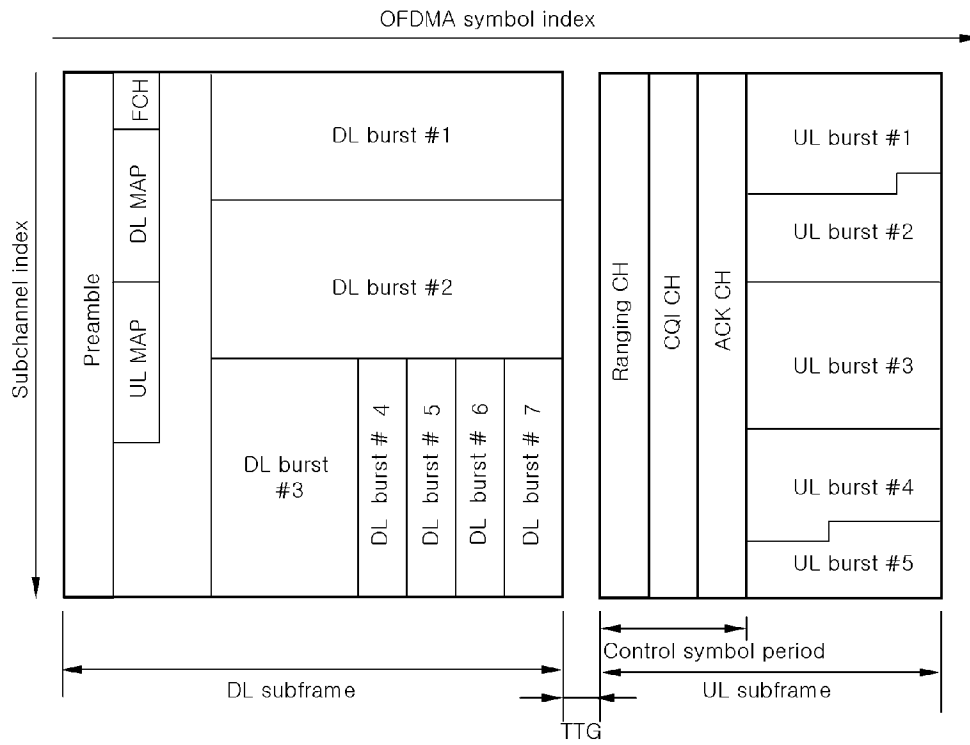

[Fig. 5]

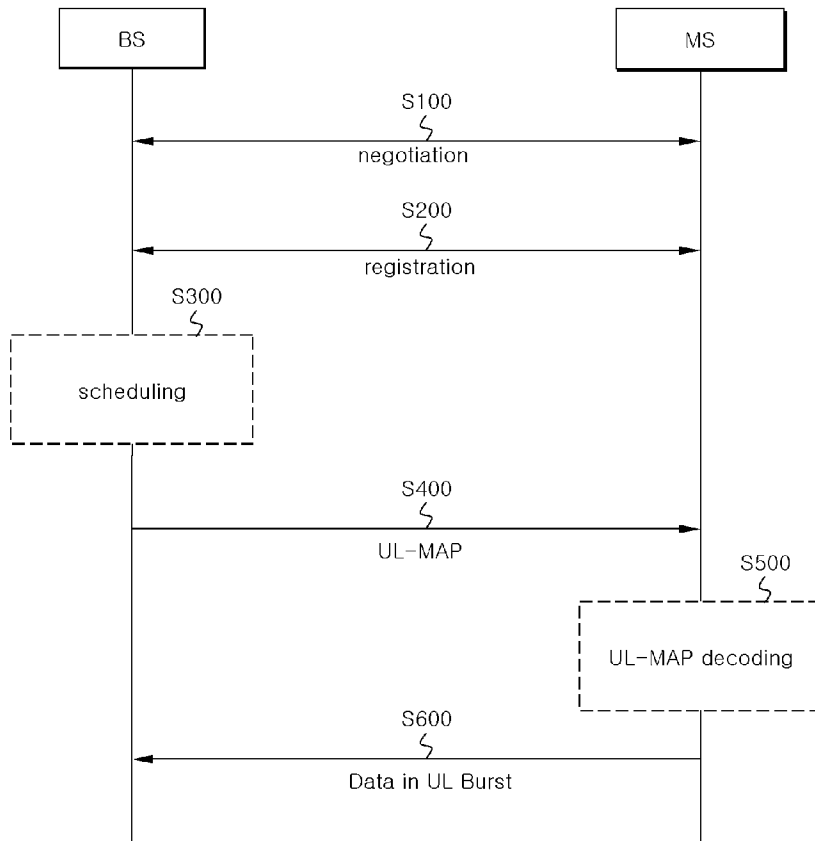

[Fig. 6]

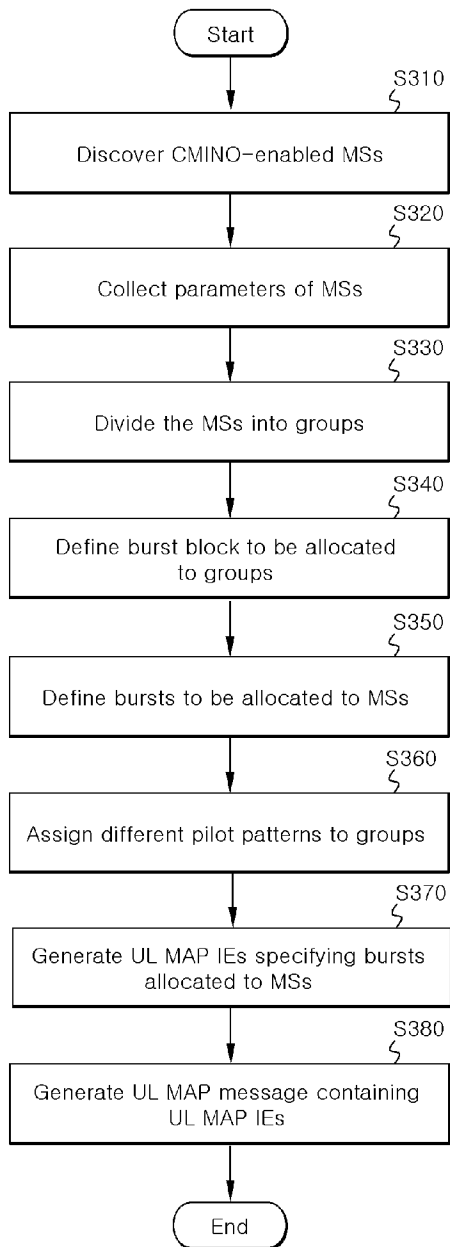

[Fig. 7]

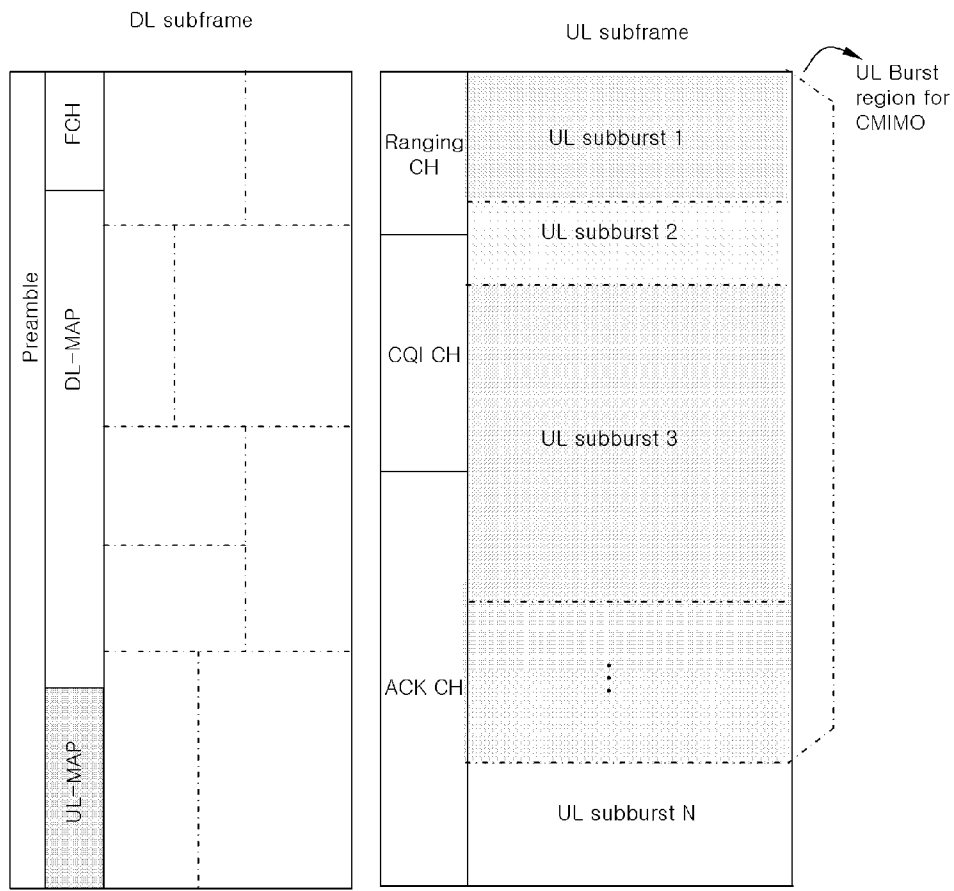

[Fig. 8]

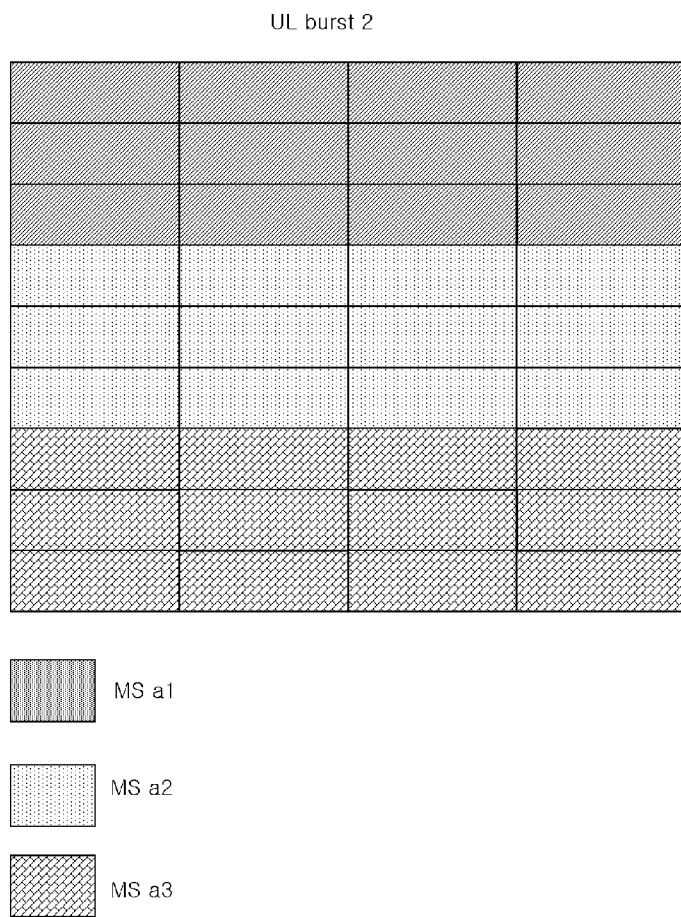

[Fig. 9]

UL burst 2

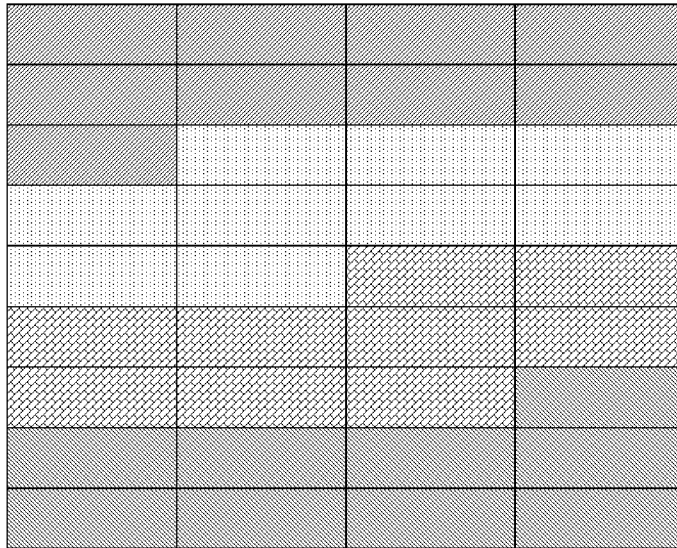

[Fig. 10]

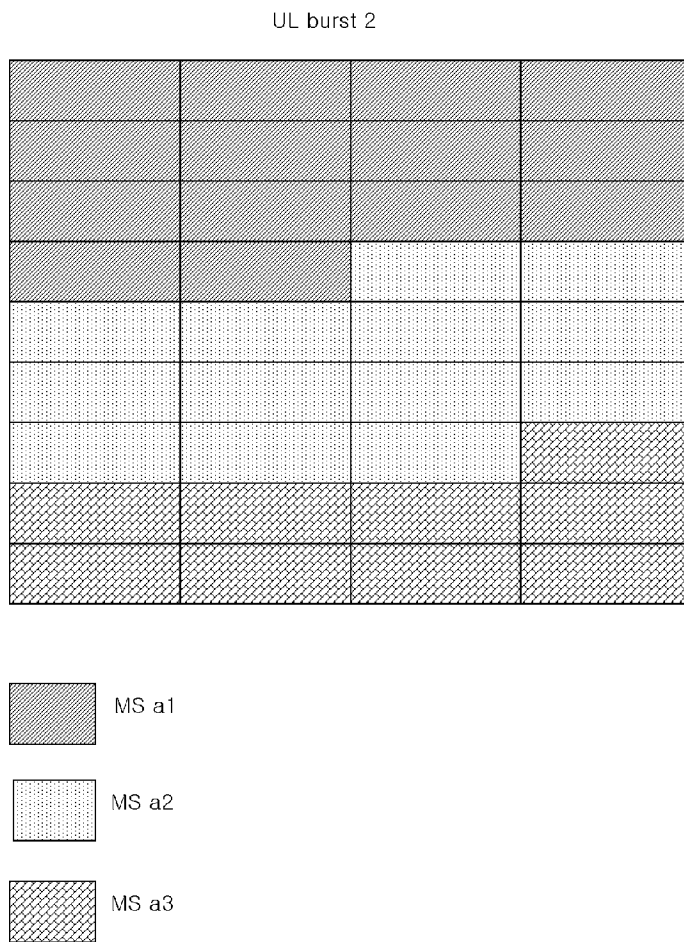

[Fig. 11]

UL burst 2

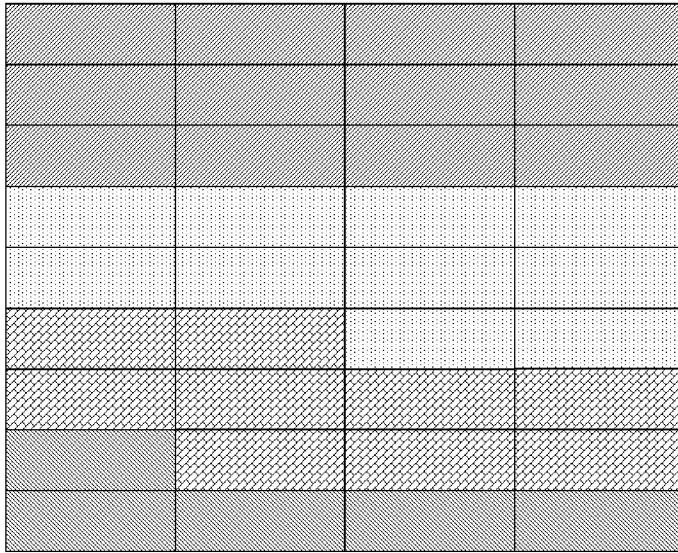
 MS b1 MS b2 MS b3 MS b4

[Fig. 12]

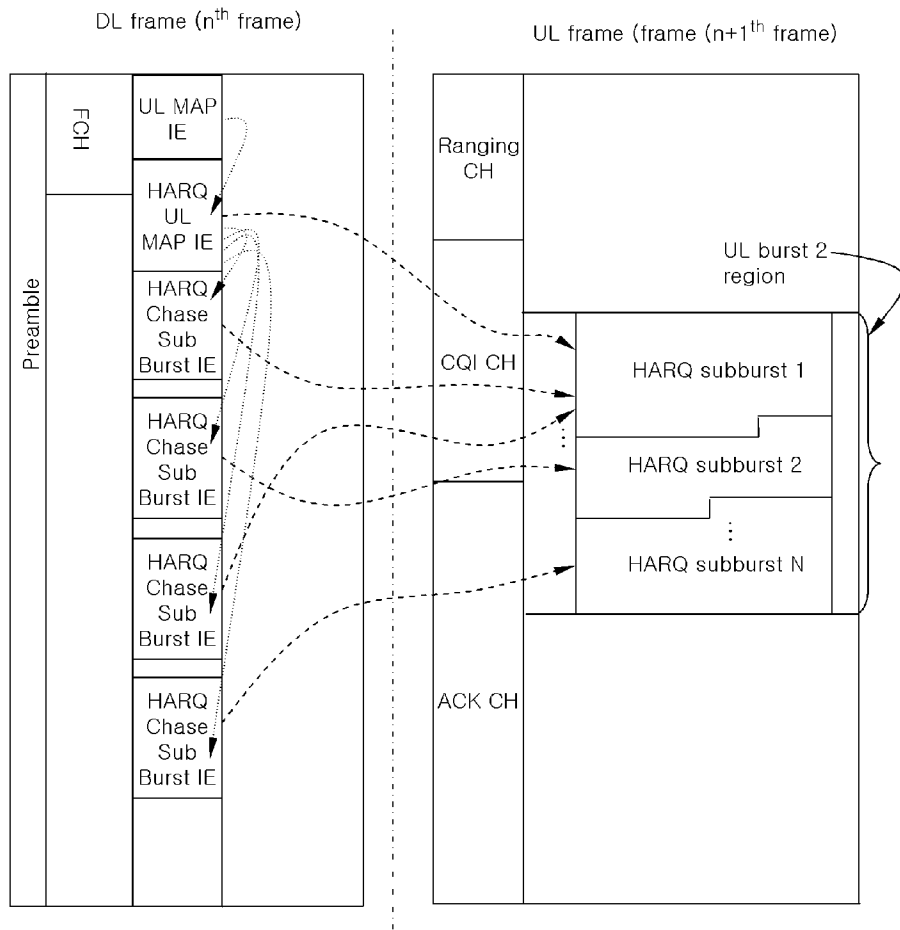

[Fig. 13]

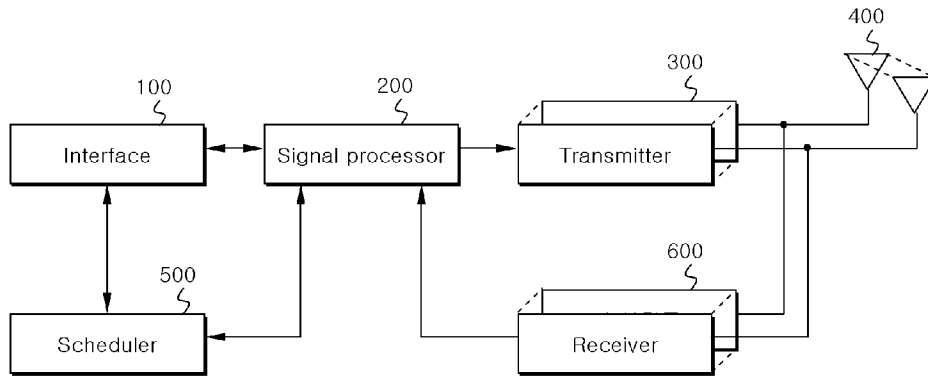

[Fig. 14]

