

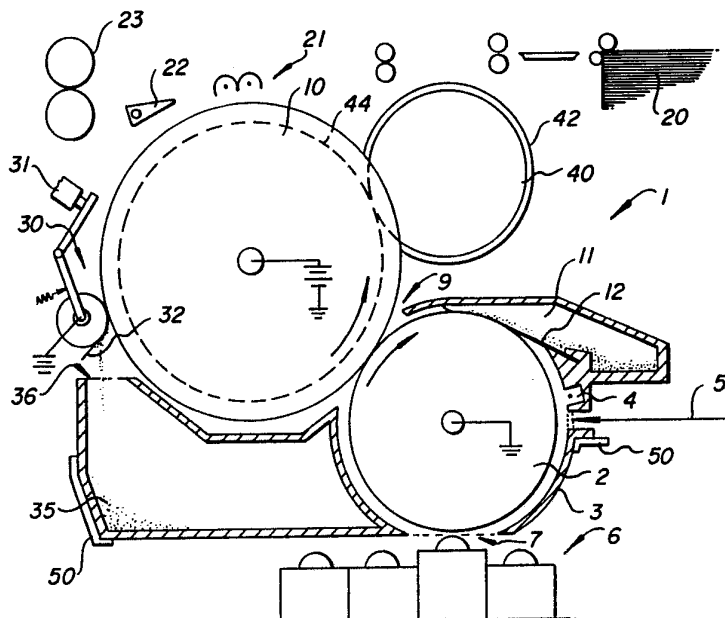

INTERNATIONAL APPLICATION PUBLISHED UNDER THE PATENT COOPERATION TREATY (PCT)

<p>(51) International Patent Classification 5 : G03G 15/01, 15/00</p>	<p>A2</p>	<p>(11) International Publication Number: WO 92/15049 (43) International Publication Date: 3 September 1992 (03.09.92)</p>
<p>(21) International Application Number: PCT/US92/00675 (22) International Filing Date: 3 February 1992 (03.02.92)</p> <p>(30) Priority data: 650,259 4 February 1991 (04.02.91) US 650,260 4 February 1991 (04.02.91) US 650,325 4 February 1991 (04.02.91) US</p> <p>(71) Applicant: EASTMAN KODAK COMPANY [US/US]; 343 State Street, Rochester, NY 14650-2201 (US).</p> <p>(72) Inventors: RYDELEK, James, Gerard ; 449 Crossfield Road, Rochester, NY 14609 (US). O'DEA, Dennis, James ; 107 Bowerman Road, Macedon, NY 14502 (US). MC DOUGAL, David, Richard ; 23 Thornfield Way, Fairport, NY 14450 (US). DE CECCA, Michael, Louis ; 7 Silver Fox Drive, Fairport, NY 14450 (US).</p>		<p>(74) Agent: TREASH, Leonard, W., Jr.; 343 State Street, Rochester, NY 14650 (US).</p> <p>(81) Designated States: AT (European patent), BE (European patent), CH (European patent), DE (European patent), DK (European patent), ES (European patent), FR (European patent), GB (European patent), GR (European patent), IT (European patent), JP, LU (European patent), MC (European patent), NL (European patent), SE (European patent).</p> <p>Published <i>Without international search report and to be republished upon receipt of that report.</i></p>

(54) Title: IMAGE FORMING APPARATUS AND IMAGE MEMBER CARTRIDGE



(57) Abstract

An image forming apparatus includes an image member (2) supplied to the apparatus in an image member cartridge (3) and a transfer member (10) which engages the image member through an access opening in the cartridge. The transfer member (10) is driven by a motor (40; 212), which may be inside the transfer drum, in the image forming apparatus and in turn drives the image member (2) in the cartridge, eliminating the need for a separate driving connection between the image forming apparatus and the image member cartridge. The cartridge is mounted in the image forming apparatus by a pair of control surfaces (115) which are fixed with respect to the shaft (111) of the transfer drum along which extensions of the shaft (105) of the image member are urged by a spring (120).

FOR THE PURPOSES OF INFORMATION ONLY

Codes used to identify States party to the PCT on the front pages of pamphlets publishing international applications under the PCT.

AT	Austria	FI	Finland	MI	Mali
AU	Australia	FR	France	MN	Mongolia
BB	Barbados	GA	Gabon	MR	Mauritania
BE	Belgium	GB	United Kingdom	MW	Malawi
BF	Burkina Faso	GN	Guinea	NL	Netherlands
BG	Bulgaria	GR	Greece	NO	Norway
BJ	Benin	HU	Hungary	PL	Poland
BR	Brazil	IE	Ireland	RO	Romania
CA	Canada	IT	Italy	RU	Russian Federation
CF	Central African Republic	JP	Japan	SD	Sudan
CG	Congo	KP	Democratic People's Republic of Korea	SE	Sweden
CH	Switzerland	KR	Republic of Korea	SN	Senegal
CI	Côte d'Ivoire	LI	Liechtenstein	SU	Soviet Union
CM	Cameroon	LK	Sri Lanka	TD	Chad
CS	Czechoslovakia	LU	Luxembourg	TG	Togo
DE	Germany	MC	Monaco	US	United States of America
DK	Denmark	MG	Madagascar		
ES	Spain				

- 1 -

IMAGE FORMING APPARATUS AND IMAGE MEMBER CARTRIDGE

TECHNICAL FIELD

5 This invention relates to an image forming apparatus which uses a cartridge containing an image member on which transferable toner images are formed. It also relates to a cartridge containing such an image member which cartridge is insertable in an image forming apparatus.

BACKGROUND ART

10 U.S. Patent 4,876,577, Ogura et al, issued October 24, 1989, shows an electrophotographic apparatus which receives a cartridge containing a photoconductive drum. The cartridge includes both a charging mechanism for charging the drum and a cleaning mechanism for
15 cleaning it. An access opening is provided for imagewise exposure of a charged surface of the drum to create an electrostatic image on the drum. The electrostatic image is toned through another access opening in the cartridge by one of two toning stations which are rotatable into position opposite the access opening to create a toner image. The toner
20 image is transferred to a receiving sheet fed through a receiving sheet opening into contact with the drum. The receiving sheet is separated from the drum by a special mechanism which is part of the cartridge and fed outside of the cartridge to a fusing device.

25 U.S. Patent 4,591,258, to Nishino et al, issued May 27, 1986, shows a cartridge containing a rotatable photoconductive drum with charging, cleaning and development stations also within the cartridge. An access opening to the drum permits transfer of toner images to a receiving sheet fed into engagement with the drum. Rotation of the drum is accomplished by a driving connection at the end of the cartridge
30 which must mate with a drive member in the receiving apparatus. Projections are provided on the cartridge to prevent damage to the cartridge driving connection member from careless handling.

35 Many other references show such image member cartridges, and they are used commercially in personal copiers and laser printers. In general, the photoconductive drum is driven by an end connection to the

- 2 -

drum through an end of the cartridge. Mounting of the cartridge in the image forming apparatus requires assuring that the drive connection is effectively made.

U.S. Patent 4,712,906, to Bothner et al, issued December 15, 1987, shows a transfer drum for a color printer. In one embodiment, a series of different color toner images are transferred to a receiving sheet carried by the drum which rotates to repeatably present the receiving sheet to an image member. In another embodiment, the different color toner images are transferred directly to the outside surface of a transfer drum to create a multicolor image on the transfer drum which is subsequently transferred in a single step to a receiving sheet at a position remote from the image member. Other references show an intermediate transfer member in the form of an endless web rather than a drum; see for example, U.S. Patent 4,453,820, Suzuki, issued June 12, 1984.

U.S. Patent 4,299,474 to Ernst et al, issued November 10, 1981, shows a compact desk-top copier in which space is saved by putting the motor, cooling system and drives for a photoconductive image member inside the image member. This structure utilizes what had previously been generally unused space to house substantial, necessary components, thereby reducing the size of the copier.

DISCLOSURE OF THE INVENTION

It is the object of the invention to simplify a cartridge containing an image member upon which a toner image is formable.

This and other objects are accomplished by an image forming apparatus which includes means for receiving a cartridge containing an image member. The apparatus includes a transfer member which engages the image member, directly or through a receiving sheet, to transfer toner images from the image member. The transfer member is driven by appropriate drive means in the apparatus. The transfer member in turn drives the image member through engagement with it.

With this invention, the image member need not have a separate driving connection to the apparatus, for example, at the end of the cartridge. This greatly simplifies the construction of the cartridge and its insertion in the image forming apparatus. Driving of the image member is accomplished instead by a component also used in toner image transfer.

- 3 -

Thus, the above object is also accomplished by a cartridge having an image member movable past a series of stations by engagement with a transfer member through an access opening in the cartridge.

5 This invention is particularly usable in a color image forming apparatus. In such apparatus, a transfer member, such as a transfer drum, engages an image member, directly or through a receiving sheet, to superpose a series of single color toner images to form a multicolor toner image.

10 It is another object of the invention to accurately position an image member loaded in an image forming apparatus as part of an image member cartridge with respect to a transfer surface associated with a transfer member which transfer member is not part of the cartridge.

This latter object is accomplished by an image forming apparatus
15 which includes a replaceable cartridge supporting an image member. The cartridge includes an access opening for transfer of toner images from the image member to a transfer surface. The image forming apparatus includes a transfer member not part of the cartridge and having a transfer surface associated with it for receiving toner images
20 from the image member. The cartridge is urged toward the transfer member to urge the image member into transfer engagement with the transfer surface. Control structure associated with the transfer member engages the cartridge to accurately position the image member with respect to the transfer member.

25 According to a preferred embodiment, the image member is drum-shaped, having a cylindrical outer image surface upon which toner images are formed as the image member rotates about an axis of rotation. The transfer member is a transfer drum also having an axis of rotation and a cylindrical outer surface. The image forming apparatus
30 includes means for controlling the relative positions of the axes of rotation of the transfer member and the image member to maintain them parallel. Maintenance of parallelism between the axes of rotation of the image member and transfer member prevents image degradation during transfer.

35 It is also an object of the invention to provide an image member cartridge which can be mounted in an image forming apparatus with the

- 4 -

image member in precise transfer relation with a transfer surface associated with a transfer member of the receiving apparatus.

BRIEF DESCRIPTION OF THE DRAWINGS

In the detailed description of the preferred embodiment of the invention presented below, reference is made to the accompanying drawings, in which:

Fig. 1 is a perspective schematic of an image forming apparatus with housing and other support parts eliminated for clarity of illustration.

Fig. 2 is a perspective view illustrating the drive train of an image forming apparatus with some parts in phantom and other parts eliminated for clarity of illustration.

Fig. 3 is a front schematic of the image forming apparatus shown in Fig. 1 with portions of an image member cartridge shown in cross section for clarity of illustration.

Fig. 4 is a front schematic of the drive train and cartridge portions of an alternative image forming apparatus with portions eliminated and broken away for clarity of illustration.

Fig. 5 is a perspective view of a cartridge and a mounting structure portion of an alternative image forming apparatus.

Fig. 6 is a perspective view of an over-center spring mechanism forming a part of the apparatus shown in Fig. 5.

Figs. 7 and 8 are front views of the structure shown in Fig. 5 in its partially loaded and fully loaded conditions, respectively.

Figs. 9 and 10 are rear views of the structure shown in Figs. 7 and 8 also in its partially loaded and fully loaded conditions, respectively.

Figs. 11 and 12 are top views of the structure shown in Figs. 5-10 in its partially loaded and fully loaded conditions, respectively.

Figs. 13 and 14 are front and rear views, respectively, of a circular disk which forms part of a knob 121 shown in Figs. 5 and 6.

Fig. 15 is a top section of a transfer drum illustrating an alternative drive mechanism for the apparatus shown in Fig. 1.

BEST MODE OF CARRYING OUT THE INVENTION

An image forming apparatus, for example, a printer 1, is shown in Fig. 1 with housing and support structures eliminated for clarity of

35

- 5 -

illustration. Printer 1 includes an image member, for example, a photoconductive drum 2 which is rotatable through a series of stations for forming a series of toner images of different colors. Photoconductive drum 2 has a cylindrical image surface which is first charged by a charging station 4 and then imagewise exposed by a laser 5 to create a series of electrostatic images. The electrostatic images are toned by toners of different color by a movable development device 6 which includes 3 or 4 separate development units. Each unit applies a different color toner to one of the series of electrostatic images to create a series of different color toner images on the cylindrical image surface of drum 2. The series of different color toner images are transferred in registration to a transfer surface associated with a transfer drum 10 to create a multicolor color image on that surface. As shown in Fig. 1, the surface to which the toner images are transferred is a cylindrical peripheral surface of drum 10 itself. However, the toner images could also be transferred to a receiving sheet held on the surface of drum 10 as is well known in the art.

The multicolor image is transferred by a transfer station 21 to a receiving sheet fed from a receiving sheet supply 45. The receiving sheet is then transported to a fuser 23 where the multicolor image is fixed and then to an output hopper 44 through an inverting path.

After transfer of the multicolor image from the surface of drum 10 to the receiving sheet, the transfer surface of the transfer drum 10 is cleaned by an articulating cleaner 30 so that it may receive a new set of images. The photoconductive drum 2 is cleaned continuously during image formation by a cleaning device 12.

As will be shown in later Figs., the photoconductive drum 2 is supplied to the printer 1 in a cartridge which cartridge may also contain other portions of printer 1. For example, the cartridge may contain the charging device 4, the developing device 6 and/or cleaning devices 30 and 12.

One example of such a cartridge is shown in Fig. 3 in which the cartridge housing is shown in section while the rest of the apparatus is shown schematically. According to Fig. 3, a cartridge housing 3 contains

35

- 6 -

image member 2, an opening for exposure by laser 5, charging device 4 and image member cleaning device 12. It also includes a sump 11 for receiving toner cleaned by cleaning device 12 off image member 2 and a sump 35 for receiving toner cleaned off transfer drum 10 by transfer drum cleaner 30. Housing 3 also includes an opening 7 providing access to image member 2 for development device 6 and an opening 9 providing access to image member 2 for transfer drum 10.

Articulating cleaner 30 is moved in and out of engagement with transfer drum 10 by a solenoid 31. It includes a cleaning roller which rolls on the surface of transfer drum 10 which roller is biased and formed of a material which encourages removal of toner to the roller. Cleaned toner is scrapped off the roller by a scraping blade 32. An opening 36 in cartridge housing 3 receives scraped toner into sump 35.

A receiving sheet is fed from a receiving sheet supply 20 into transfer relation with transfer drum 10. In the structure shown in Fig. 3, transfer is accomplished by a corona transfer station 21, known in the art. The transfer sheet is picked off transfer drum 10 by a movable pick-off 22 which also directs the transfer sheet to fuser 23.

Prior cartridges which contained image members such as photoconductive drum 2 included a relatively complex drive connector at one end of the cartridge which must be engaged with an appropriate drive in the receiving apparatus to rotate drum 2 past the toner image forming stations. As shown in Figs. 2 and 3, the need for such a drive connector is eliminated. A motor 42 drives a drive gear 40 which in turn drives a gear 44 connected to transfer drum 10. Transfer drum 10 is made up of material somewhat softer than photoconductive drum 2, for example, polyurethane. Photoconductive drum 2 engages transfer drum 2 through opening 9 and is frictionally driven by transfer drum 10 for its entire operation. Thus, opening 9 provides access to image member 2 for both transfer and for frictional, driving engagement with transfer drum 10. With this structure, no separate drive connection needs to be made between transfer drum 2 and the receiving apparatus. This greatly simplifies the manufacture of the cartridge and its cost as well as loading of the cartridge 3 in the printer 1. Fig. 2 is a perspective drawing

35

- 7 -

illustrating the drive train from motor 42 through transfer drum 10 and photoconductive drum 2.

The term "engagement" as used herein with reference to the image member and the transfer member is preferably direct contacting engagement of those members. However, although not preferred, it can also be engagement through a receiving sheet carried by the transfer member.

Although transfer drum 10 is shown with an external drive engagement between transfer drum 10 and motor 42, motor 42 could be positioned inside transfer drum 10 and internally engaged with drum 10 to save space in printer 1. This latter embodiment is shown in Fig. 15.

According to Fig. 15, transfer drum 10 includes an outer layer 201 of polyurethane cast or otherwise formed on an aluminum or steel base 202. Layer 201 defines a cylindrical transfer surface 207 to which several single color toner images are transferred directly to form a multicolor image. A pair of gudgeons 203 and 204 support base 202 and are journaled for rotation about fixed shafts 205 and 206.

Shafts 205 and 206 rotate about different portions of a single axis of rotation and are considered a single shaft for all purposes herein. Shafts 205 and 206 are fixed in mechanism plates 208 and 209 of the printer, and support an internal drive housing 210 located inside transfer drum 10. Internal drive housing 210 includes a motor 212 and planetary gear box 213. The planetary gear box provides a suitable gear reduction between the motor and an output shaft 221. A drive gear 222 is fixed on output shaft 221 and is rotated by output shaft 221 to drive a first idler gear 225. First idler gear 225 is fixed to an idler shaft 226 journaled for rotation with respect to drive housing 210. A second idler gear 227 is also fixed to and is rotated by idler shaft 226. Second idler gear 227 engages an internal gear 230 fixed to the inside of drum base 202 to rotate drum 10 with respect to shafts 205 and 206 and housing 210. A hole 217 in the center of shaft 206 provides an exit for wiring the motor 212.

With the structure shown in Fig. 15, transfer drum 10 comes to printer 1 with its own internal drive. That drive does not need to be

35

- 8 -

separately mounted in the printer, saving a step in printer final assembly. More importantly, the drive does not take up space in the printer, allowing the printer to be more compact.

The structure shown in Fig. 15 is particularly useful to drive a
5 transfer drum 10 which receives toner images directly to its surface and then transfers them to a receiving sheet, because such a drum does not require a vacuum source or other structure for holding a receiving sheet to the drum surface, thereby leaving the room necessary for the transfer drum drive housing 210. It is also particularly useful with a cartridge
10 loading image member 2 as shown in Figs. 2-5 which image member is driven by transfer drum 10, since, with such a structure, no usable space is taken up in printer 1 for a drive for either of drums 10 or 2.

Although driving the image member 2 utilizing peripheral
engagement with transfer drum 10 through access opening 9 greatly
15 simplifies cartridge 3, some precision in the placement of cartridge 3 is important in this apparatus. In the structure shown in Fig. 3, cartridge 3 is shown supported by receiving mechanism 50 which positions the cartridge so that sufficient engagement between drum 2 and drum 10 is
20 obtained to both transfer images and drive drum 2. For best image quality, it is necessary to control both the size of the nip between the drums and to maintain the axes of rotation of the drums parallel. To do this with the Fig. 3 construction is feasible for modest image quality. However, for highest image quality, tolerances in the manufacture of cartridge 3, receiving structure 50 and the location of drum 10 become
25 confining. Accordingly, more precise positioning mechanisms are shown in Figs. 4-14.

According to Fig. 4, cartridge 3 includes drum 2, charging station 4 and cleaning device 12, but does not include a sump for receiving toner cleaned from drum 10. Transfer drum 10 is supported on a shaft 51
30 which, in turn, is supported by a pair of mechanism plates of the apparatus, for example, mechanism plates 208 and 209, shown in Fig. 15. Also supported on shaft 51 are a pair of triangularly shaped plates 52 at opposite ends of drum 10. Plates 52 are also connected by an auxiliary shaft 54 and are generally rotatable about shaft 51 but rigidly fixed with
35 respect to each other.

- 9 -

Photoconductive drum 2 is supported for rotation about an axis 56 by a shaft 57 which shaft extends beyond the end walls of cartridge 3. Drum 2 rotates with respect to shaft 57, so shaft 57 is fixed with respect to cartridge 3. A slot 55 in each of triangular plates 52 is
5 shaped to receive snugly the ends of shaft 57.

To load cartridge 3 in the embodiment shown in Fig. 4, plates 52 can be rotated to a position slightly counterclockwise from that shown in Fig. 4 to receive shaft 57 into slots 55. Plates 52, transfer drum 10 and cartridge 3 are then rotated clockwise around shaft 51 until plates 52 rest
10 on a stop 62 which is a permanent portion of printer 1. The cartridge 3 can still be rotated about shaft 57 until a portion of cartridge 3 rests on another stop 61 which is also a permanent part of printer 1.

Slots 55 in plates 52 are parallel with each other and define control surfaces which maintain a parallel relation between the axes of
15 rotation of drums 10 and 2. Stops 61 and 62 generally orient the cartridge in printer 1 for access to the exposing and developing devices 5 and 6 (Figs. 1 and 3). The nip between drums 10 and 2 is controlled by a spring 65 which urges cartridge 3 toward transfer drum 10 and the image surface of drum 2 into engagement with the transfer surface
20 associated with drum 10. A spring 67 may also be used to maintain the contact between cartridge 3 and stop 61, thereby preventing rotation of the cartridge around shaft 57. Spring 67 may not in fact be necessary, since the rotation of transfer drum 10 will also urge cartridge 3 against stop 61. However, spring 67 can be part of an upper part of printer 1
25 which, after the insertion of cartridge 3 is closed onto a lower part, which lower part holds motor 42, transfer drum 10, laser 5, development device 6 and associated support structure. Spring 65, although part of the lower portion of the apparatus, can also be tensioned and/or applied to cartridge 3 as part of this closing operation.

30 Figs. 5-12 show another approach to positioning an image member cartridge in an image forming apparatus similar to that shown in Fig. 1. According to Fig. 5, a cartridge 103 containing an image member 2 is to be loaded into an apparatus which includes a transfer drum 10 with the axes of rotation of drums 2 and 10 sufficiently parallel to avoid

35

- 10 -

image degradation during transfer of high quality images, which images must be registered with great accuracy to form a quality multicolor image.

5 Transfer drum 10 is supported on a shaft 111, which, in turn, is supported by front and rear guide plates 112 and 113, respectively. Shaft 111, of course, may be in two sections as are shafts 205 and 206 shown in Fig. 15. Guide plates 112 and 113 extend substantially to the right from transfer drum 10 and each include control surfaces 115 and support surfaces 116 which cooperate with portions of cartridge 103.

10 As best seen in Figs. 7-10, an over-center spring mechanism 120 is actuated to drive cartridge 103 from an unloaded condition shown in Figs. 7 and 9 to a fully loaded condition shown in Figs. 8 and 10.

15 Cartridge 103 is positioned in the apparatus by the operator resting left and right rear support bosses 131 and 132, respectively, on rear support surface 116 as shown in Fig. 9, a single front support boss 133 on front guide surface 116, with all three support bosses thus resting on support surfaces 116. Support surfaces 116 are generally horizontal.

20 Drum 2 is mounted in cartridge 103 on a support shaft 105 (which also may be in two sections as shown in Fig. 15), and rotates about an axis at the center of the shaft. Over-center spring 120 is actuated (as described below) to push cartridge 103 to the left as shown in Fig. 8. This action pushes shaft 105 into contact with control surfaces 115 of guide plates 112 and 113. Control surfaces 115 are parallel with each other. Their projection is generally tangent to transfer drum shaft 25 111. As seen in Figs. 8 and 10, over-center spring 120 pushes cartridge 103 until shaft 105 rides up control surfaces 115 until drum 2 engages transfer drum 10. A notch 119 in guide plates 112 and 113 causes cartridge 103 to no longer be supported by bosses 131 and 133.

30 Thus, in its fully loaded condition shown in Figs. 8 and 10, with drum 2 engaging drum 10, cartridge 103 is supported only by the ends of shaft 105 riding up parallel control surfaces 115 and by boss 132 resting on support surface 116. This three-point contact forces shaft 105 to

- 11 -

always contact both control surfaces 115. Thus, to the extent that the peripheral surfaces of drums 2 and 10 are cylindrical and accurately mounted on shafts 105 and 111, and the location of control surfaces 115 are accurate, the axes of drums 2 and 10 will be parallel.

5 The extent of the parallelness between the axes is a determining factor on the image quality in transfer. If, for example, the support boss 133 were allowed to continue to contact guide surface 116, it would be possible for either end of shaft 105 to become out of contact with its control surface 115, thereby losing parallelness between the axes of
10 rotation of the drums. This might be overcome by preciseness in the manufacture of the housing of cartridge 103 and bosses 132 and 133. However, with the structure shown in Figs. 5-12, the only items required to be precise in the cartridge are the drum 2 and its support shaft 105. In the receiving apparatus, control surfaces 115 also must be accurately
15 positioned with respect to shaft 111 and shaft 111 must be accurately positioned with respect to transfer drum 10.

 A roller 160 is shown in Figs. 11 and 12, and is part of a structure to prevent movement of cartridge 103 to the rear. A complementary roller or spring to the front of the path of cartridge 103
20 is not shown.

 It also may be desirable to urge the top of the cartridge gently in a downward direction during operation to prevent engagement of the drums from unseating it. This can be accomplished with a spring applied as part of closing the apparatus after loading of cartridge 103.

25 Cartridge 103 can be pushed to the left (as seen in Fig. 8) by any appropriate spring mechanism. However, Figs. 6, 11 and 12 illustrate an over-center spring mechanism 120 which is particularly useful for this function.

 As best seen in Figs. 5, 6, 11 and 12, a support housing 125 is
30 attached to printer 1 by suitable means, not shown, and supports the rest of over-center spring mechanism 120. Referring to Fig. 6, a customer actuated knob 121 is rotated by the person inserting cartridge 103. Knob 121 is keyed through a shaft 122 to a drive roller or gear 128. Rotation of knob 121 rotates drive roller 128 which in turn rotates a driven roller
35

- 12 -

123. Driven roller 123 is keyed to a lever 124 through a shaft 126. Thus, rotation of knob 121 rotates lever 124 around shaft 126. Lever 124 pushes cartridge 103 into its loaded condition and holds it there with the desired force urging engagement of drums 2 and 10.

5 A pair of springs 127 are mounted between a spring support 141 on housing 125 and a spring support rod 142 (Fig. 5) on lever 124. Shaft 126 is between the attaching positions of springs 127. Thus, springs 127 have a dead-center position between latched and unlatched conditions of lever 124 where the shaft 126 lines up with the attaching positions. That
10 is, as knob 121 is rotated in a counterclockwise direction as seen in Fig. 6, lever 124 is driven in a clockwise direction toward a latching position urging cartridge 103 to the left until photoconductive drum 2 engages transfer drum 10. In this movement, spring 127 goes through a "dead-center" position in which it is at its maximum length and therefore
15 its maximum stressed condition. Further clockwise rotation of lever 124 causes springs 127 to urge lever 124 into engagement with cartridge 103 and cartridge 103 into its loaded condition as shown in Fig. 8. To unload cartridge 103, knob 121 is rotated in a clockwise direction to rotate lever 124 in a counterclockwise direction as seen in Fig. 6 until
20 springs 127 pass through their dead center position. At this point, further rotation of knob 121 is aided by springs 127 urging lever 124 toward its totally unlatched position, shown in Fig. 5 with lever 124 resting against a pair of lever stops 143 where lever 124 will not interfere with removal of the cartridge. Thus, with the over-center spring structure
25 120, lever 124 is generally urged by springs 127 toward either a latched condition shown in Figs. 6, 8, 10 and 12 or toward an unlatched condition shown in Figs. 5, 7, 9 and 11.

Knob 121 can be constructed so that the customer who is loading the cartridge does not, in fact, feel the final positioning of the cartridge
30 in its loaded condition or the positioning of lever 124 against stops 143. Knob 121 includes a circular plate 149, the front and rear sides of which are shown in Figs. 13 and 14, respectively. Drive shaft 122 is positioned in a hole 152 through plate 149. The front surface of plate 149 includes a groove 153 contiguous with the front portion of hole 152. Shaft 122

35

- 13 -

includes a protrusion 154 which rides in groove 153 except where not permitted by ends 156 and 157 of the groove 153.

In operation, knob 121 is turned in either direction until protrusion 154 engages one of groove ends 156 or 157. From that point
5 on, rotation of knob 121 rotates shaft 122 until the "over-center" condition of springs 127 occurs. At this point, the spring accelerates the rotation of lever 124 in either a latching or unlatching direction causing the shaft 122 to rotate ahead of either groove end 156 or 157 until lever 124 reaches its fully latched or unlatched condition. This design has the
10 advantage of fully positioning the lever 124 without the spring acceleration of lever 124 or its stopping being felt by the person rotating knob 121. It also discourages over rotation of lever 124 by the operator which can damage cartridge 103 or drums 2 or 10.

The positioning device shown in Figs. 5-14 positions the
15 photoconductive drum 2 against the transfer drum 10 with the axes of revolution of the two drums parallel. Precision is required in only the manufacture and assembly of shafts 111 and 105, drums 2 and 10 and guide surfaces 115. This parallelism is important to prevent image degradation in high-quality transfer. This makes it particularly usable in
20 a multicolor printer providing high-quality multicolor images which are the result of superimposing a series of single color images. It is particularly usable when the photoconductive drum is driven by the transfer drum (as shown in Figs. 1-4) because such driving engagement between the two drums requires a substantial nip which increases the
25 degradation of the image if the axes are not parallel. However, it certainly can be used in structures in which the photoconductive drum 2 is driven by its own drive means and either drives the transfer drum or is driven independently of it.

Note that the manufacture and location of bosses 131, 132 and
30 133 are not critical to parallelism of the axes, nor is the manufacture of guide surfaces 116. Note also that guide surface 115 maintains parallelism of shafts 105 and 111. If the two shafts are the same size, surfaces 115 should be parallel with each other and their extensions should be tangent to the periphery of shaft 111. If shaft 111 is larger
35 than shaft 105, extensions of guide surfaces 115 should intersect

- 14 -

shaft 111 accordingly. Shaft 105 is preferably a stationary shaft with photoconductive drum 2 mounted for rotation with respect to it. This eliminates the necessity of making guide surfaces 115 bearing surfaces. Shaft 111 can rotate with transfer drum 10 or be stationary,
5 with transfer drum 10 rotating with respect to it as shown in Fig. 15.

Shaft 105 could be rotatable with photoconductive drum 2. In such a design, it would be preferable to have shaft 105 supported for rotation in bearings, which bearings have a housing which contacts guide surfaces 115. Alternatively, if surfaces 115 are made of self-lubricating
10 material, shaft 105 can rotate with drum 2 on surfaces 115.

Although each of the positioning structures shown herein has particular adaptability and is designed for a transfer drum 10 which receives toner images directly on its outer transfer surface, the structures can also be used with a transfer drum which supports a receiving sheet
15 on its outer surface.

The invention has been described in detail with particular reference to a preferred embodiment thereof, but it will be understood that variations and modifications can be effected within the spirit and scope of the invention as described hereinabove and as defined in the
20 appended claims.

25

30

35

- 15 -

I Claim:

1. An image forming apparatus comprising:
a replaceable cartridge(3) containing an image drum(2) having a peripheral image surface, said image drum being supported in said cartridge for rotation to move its image surface past a series of stations to form a series of different color toner images on said image surface, and said cartridge having means defining access to the image surface for transfer of said images in registration to a transfer surface to form a multicolor image,
5
10 a transfer drum(10) having associated therewith a transfer surface which transfer surface is frictionally engageable with the image surface of said image drum through said access defining means, and means(40;212) for rotating said transfer drum to in turn rotate said image drum through the frictional engagement of said transfer and
15 image surfaces.
2. An image forming apparatus according to claim 1 wherein said transfer surface is a cylindrical outer surface of said transfer drum.
3. An image forming apparatus according to claim 1 wherein said transfer surface is an outer surface of a receiving sheet secured to a
20 cylindrical outer surface of said transfer drum.
4. An image forming apparatus according to claim 2 further including means(21) for transferring a multicolor toner image from the transfer surface to a receiving sheet.
5. An image forming apparatus according to claim 1 wherein at
25 least one of said series of stations is positioned inside said cartridge.
6. An image forming apparatus according to claim 5 wherein said at least one station is a charging station.
7. An image forming apparatus according to claim 6 wherein said image drum is a photoconductive drum and said cartridge further
30 includes a cleaning station where said photoconductive drum is cleaned, and an opening through which exposure light can pass to form electrostatic images on said photoconductive drum.

35

- 16 -

8. An image forming apparatus according to claim 1 wherein said means for rotating said transfer drum(10) includes a motor(212) located inside said transfer drum.

9. An image forming apparatus comprising:

5 a replaceable cartridge supporting a drum-shaped image member, said image member having a cylindrical outer image surface and an axis of rotation,

10 a transfer drum having an axis of rotation and a transfer surface associated with said transfer drum for receiving toner images from said image surface,

means for urging said cartridge towards said transfer member to urge said image surface into transfer engagement with said transfer surface, and

15 means associated with said transfer drum for controlling the position of the axis of rotation of said image member to maintain the axis of rotation of said image member parallel to the axis of rotation of said transfer drum.

10. An image forming apparatus comprising:

20 a replaceable cartridge having a housing and a drum-shaped image member, a shaft supporting said image member for rotation about an axis of rotation, said shaft having opposite ends which extend beyond opposite ends of said image member and are accessible from outside of said cartridge housing, said image member having an image surface upon which toner images are formable,

25 a transfer drum having an axis of rotation and a cylindrical outer transfer surface for receiving toner images from said image surface, and

30 means fixed with respect to the axis of rotation of said transfer drum for controlling the position of the shaft supporting the image member to maintain the axis of rotation of said image member parallel to the axis of rotation of said transfer drum.

11. An image forming apparatus according to claim 10 wherein said shaft is fixed with respect to said cartridge and said image member is mounted for rotation with respect to said shaft and said shaft has opposite ends which extend outside of said cartridge for engagement by
35 said controlling means.

- 17 -

12. An image forming apparatus according to claim 10 and further including means for urging said cartridge toward said transfer drum to urge said image surface into engagement with said transfer surface.

5 13. An image forming apparatus according to claim 12 wherein said controlling means includes at least a pair of control surfaces, one control surface engaging each opposite end of said shaft, said control surfaces running from positions of engagement of said control surfaces with the ends of said shaft toward said transfer drum, and said urging
10 means including means for urging said cartridge in a direction maintaining contact between the ends of the shaft and said control surfaces while also urging said image surface into engagement with said transfer surface.

14. An image forming apparatus according to claim 10 wherein
15 said transfer drum is supported by a shaft having opposite ends, which ends are fixed with respect to said controlling means.

15. An image forming apparatus comprising:
a replaceable cartridge having a cartridge housing and an image member mounted on a shaft in said housing for rotation about an axis of
20 rotation to bring an image surface of said image member past a series of stations to form toner images on said image surface,

a transfer drum rotatable about an axis of rotation to bring a transfer surface incrementally through transfer relation with the image surface to transfer toner images from said image surface to said transfer
25 surface,

means for urging said image surface into transfer relation with said transfer surface, and

means fixed with respect to said axis of rotation of said transfer drum for engaging said shaft to maintain said axes of rotation parallel.

30 16. An image forming apparatus according to claim 15 wherein said image member is rotatable by said transfer member through engagement between said image surface and said transfer surface.

17. An image forming apparatus according to claim 15 including means for supporting said cartridge entirely at three positions, two of
35 said positions supporting said shaft at positions on said shaft at opposite ends of said image member.

- 18 -

18. An image forming apparatus according to claim 17 wherein the other of said three positions is at a support boss extending from said cartridge housing.

19. An image member cartridge comprising:

5 a cartridge housing(3),

an image member(2) supported for rotation about an axis to move said image member past a series of stations at least one(4) of which is located inside said cartridge to create a series of toner images on said image member, and

10 means defining an opening to said image member through which a toner image is transferable from said image member to a moving surface and through which said image member is movable by engagement with such a moving surface.

20. An image member cartridge comprising:

15 a housing,

a photoconductive drum having a cylindrical image surface, said drum being mounted for rotation in said housing,

means for uniformly charging said surface,

20 an optical opening in said housing through which said surface is exposable to create a series of electrostatic images,

an opening in said housing through which said electrostatic images are developable by application of toners of colors that are different from image to image to create a series of different color toner images, and

25 an opening in said housing through which said toner images are transferable by contact with a moving transfer surface and through which said drum is rotatable by said moving transfer surface.

21. An image member cartridge insertable in image forming apparatus, comprising:

30 a cartridge housing,

an image member having an image surface, said image member being supported for movement to create a toner image on said image surface,

35 means defining an opening in said housing to said image member through which a toner image on said image member is transferable to a moving transfer surface carried by a transfer member of an image forming apparatus, and

- 19 -

means fixed to said cartridge for cooperating with an image forming apparatus to maintain the axis of rotation of said image member parallel to an axis of rotation of a transfer member of the image forming apparatus.

5

10

15

20

25

30

35

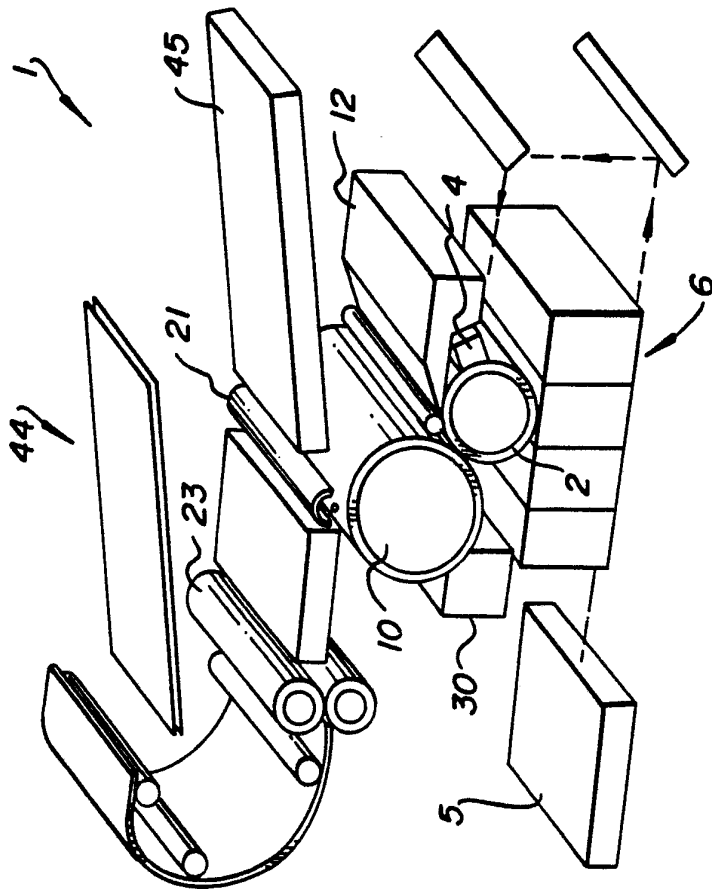

Fig. 1

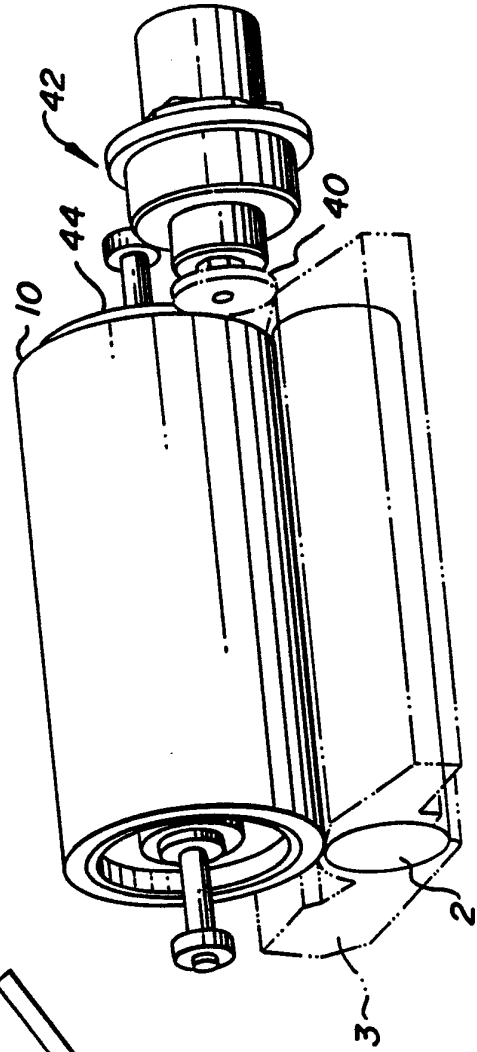

Fig. 2

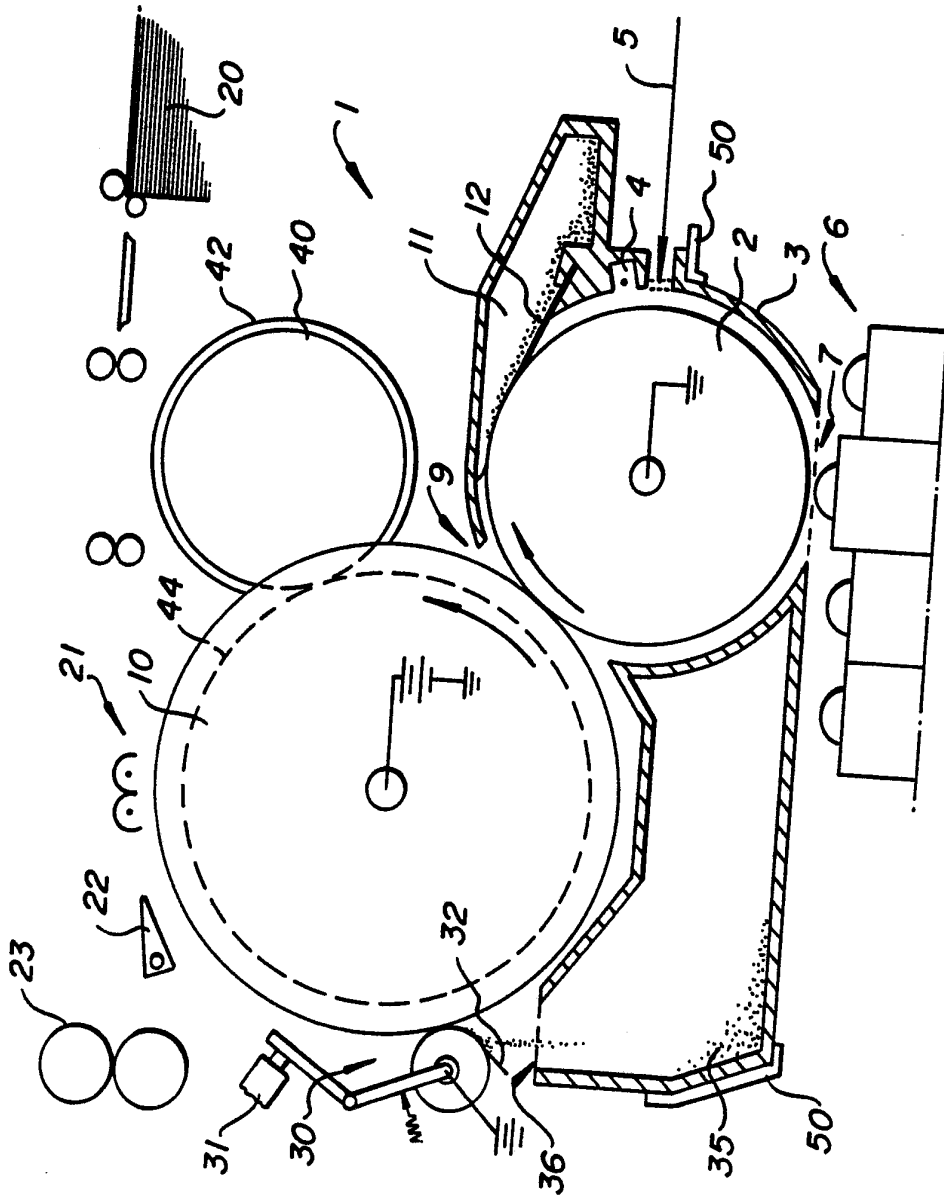

Fig. 3

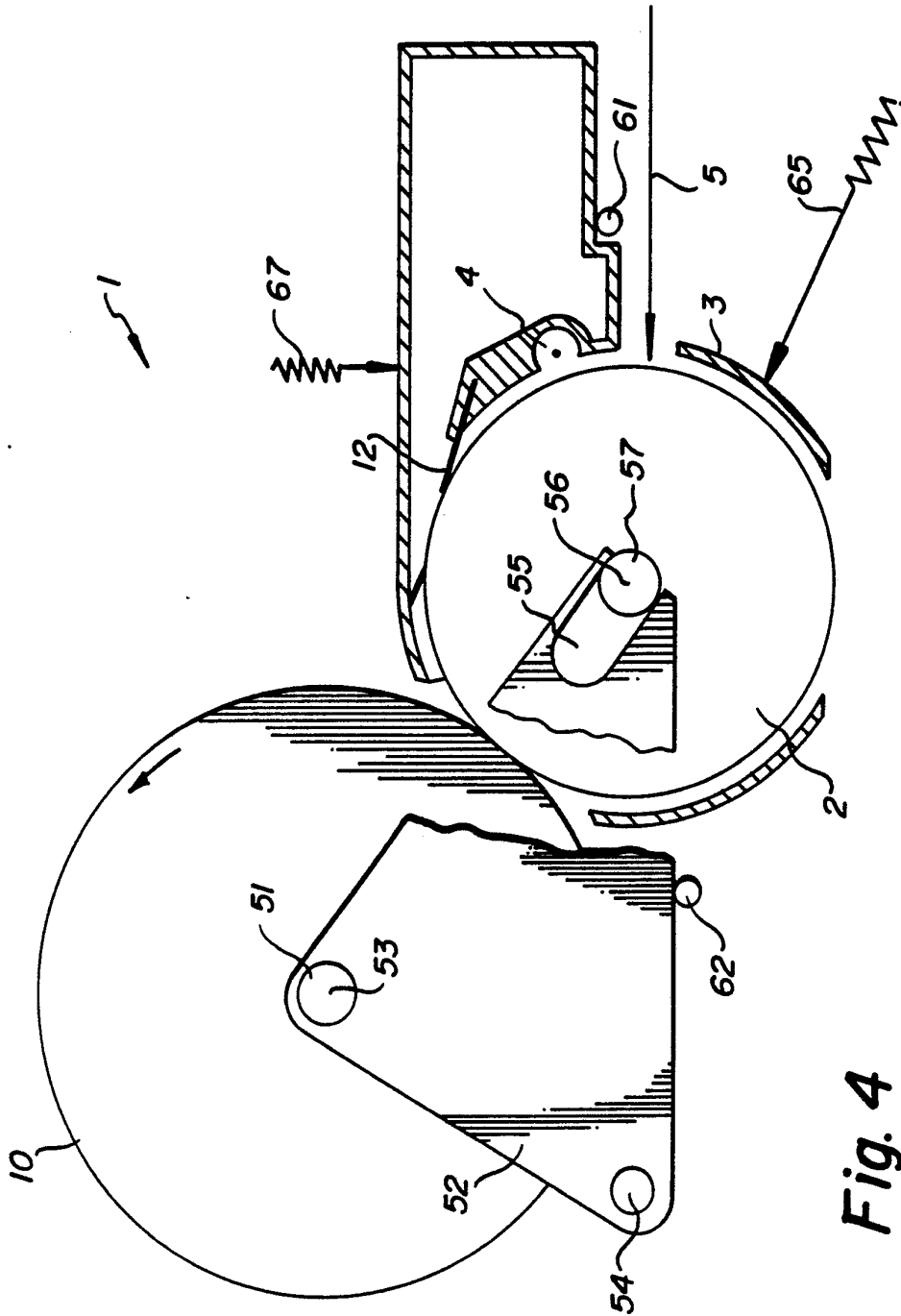

Fig. 4

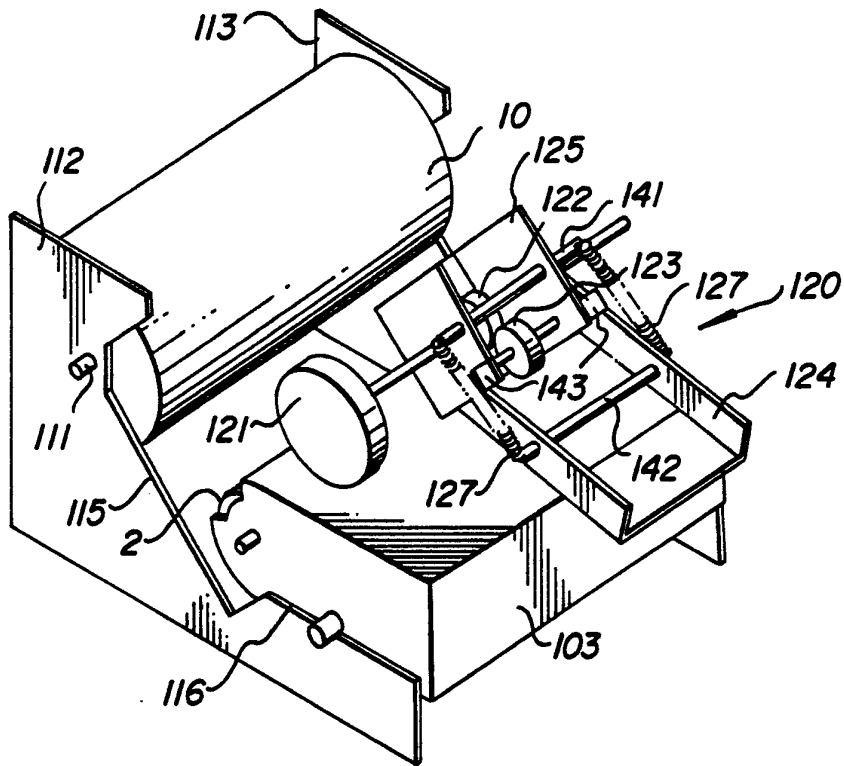

Fig. 5

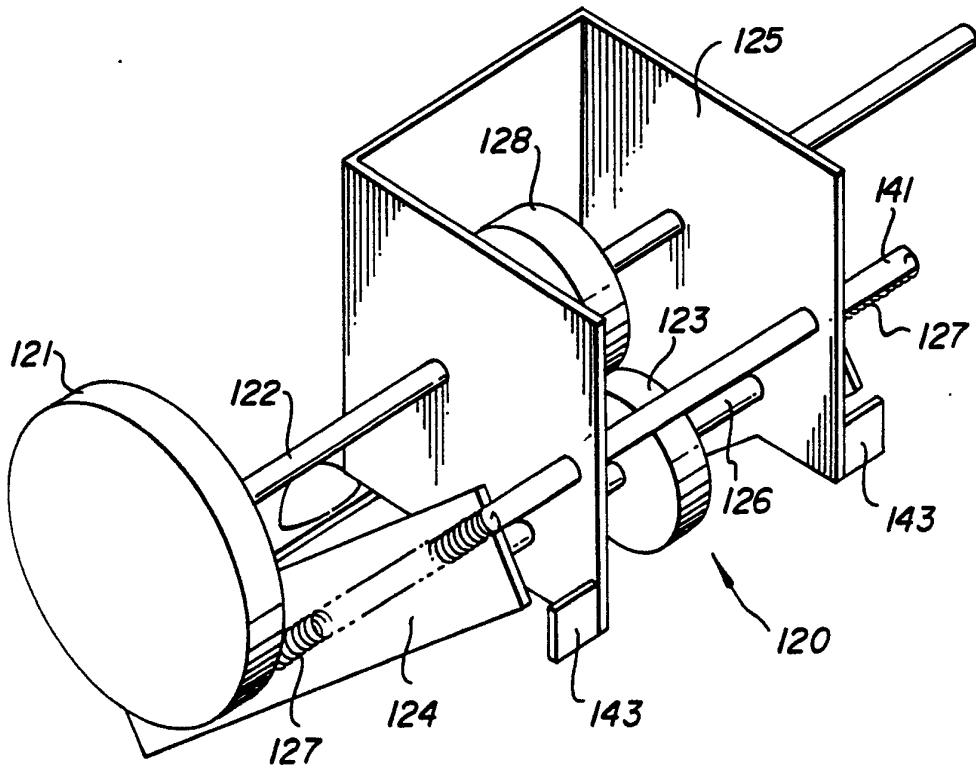

Fig. 6

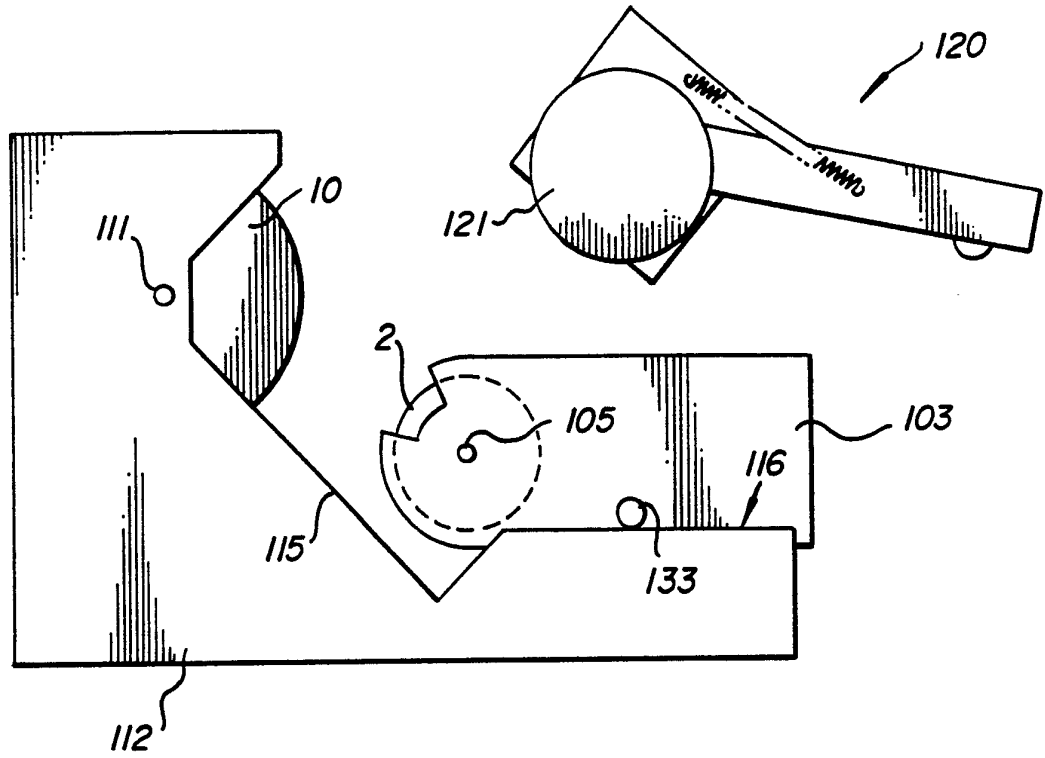

Fig. 7

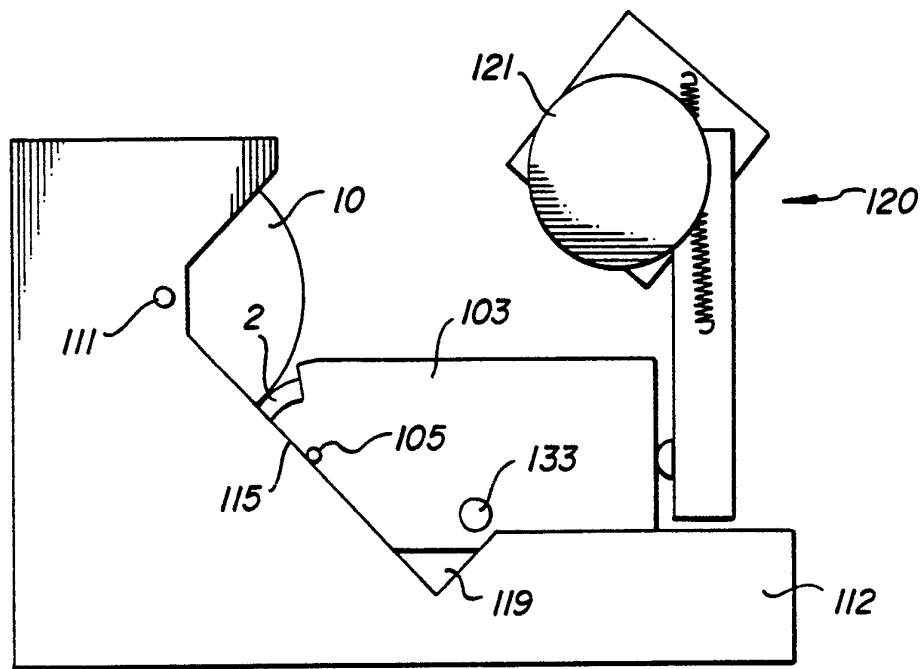

Fig. 8

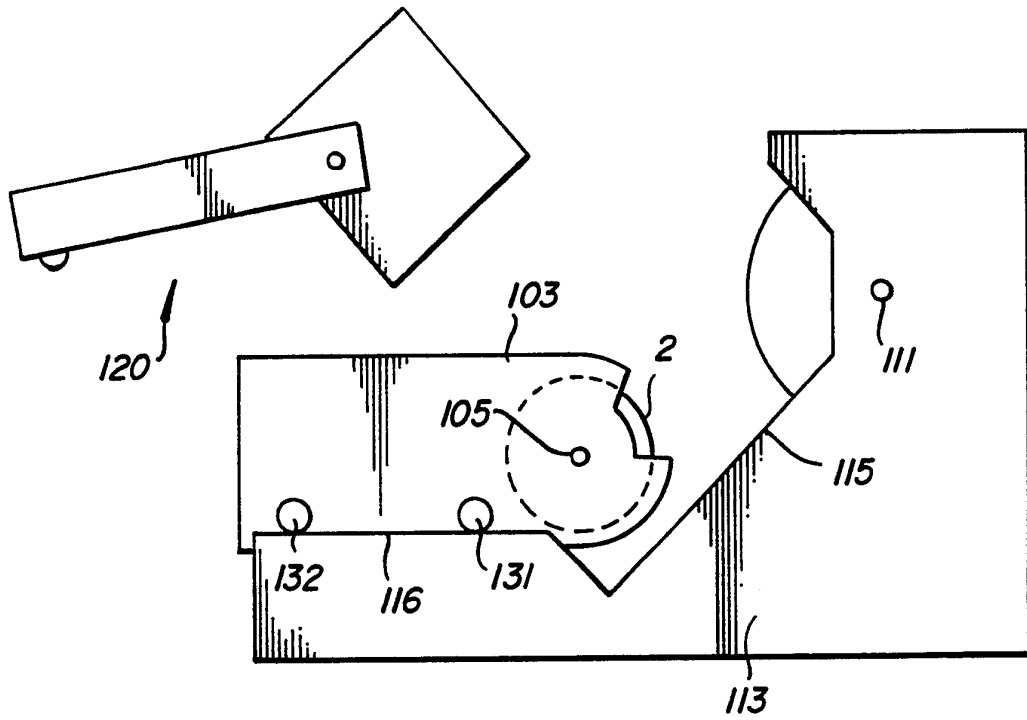

Fig. 9

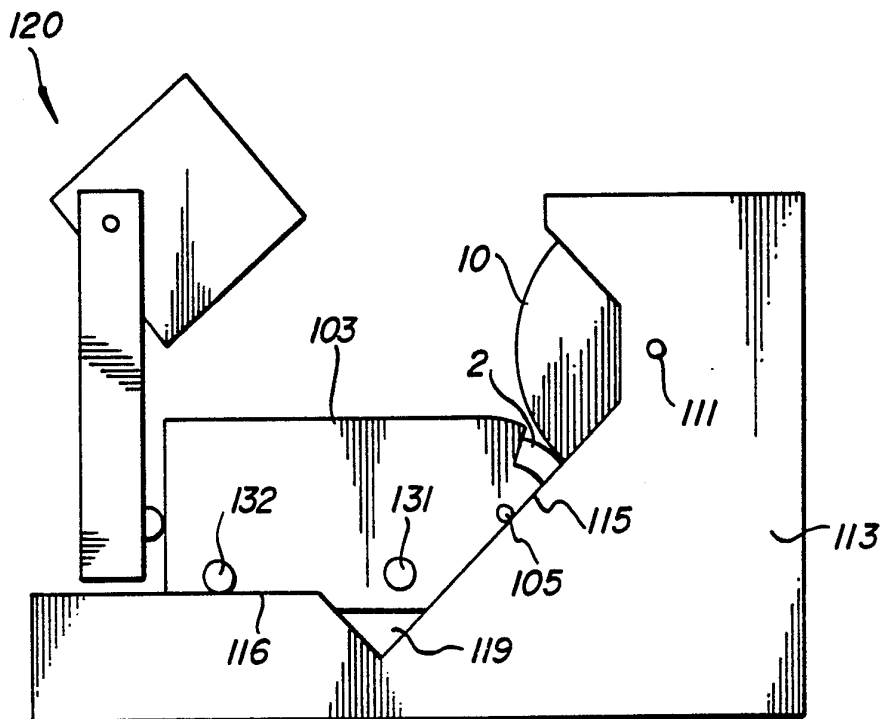

Fig. 10

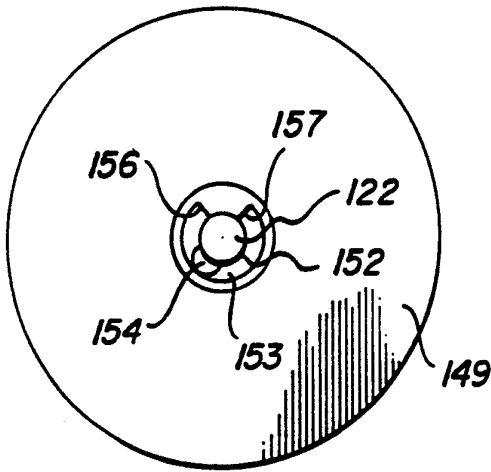

Fig. 13

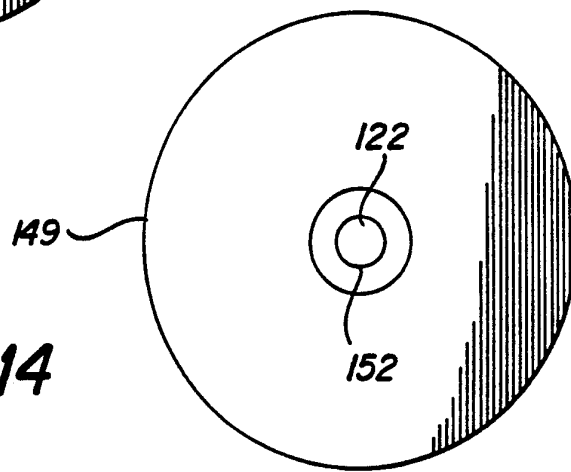

Fig. 14

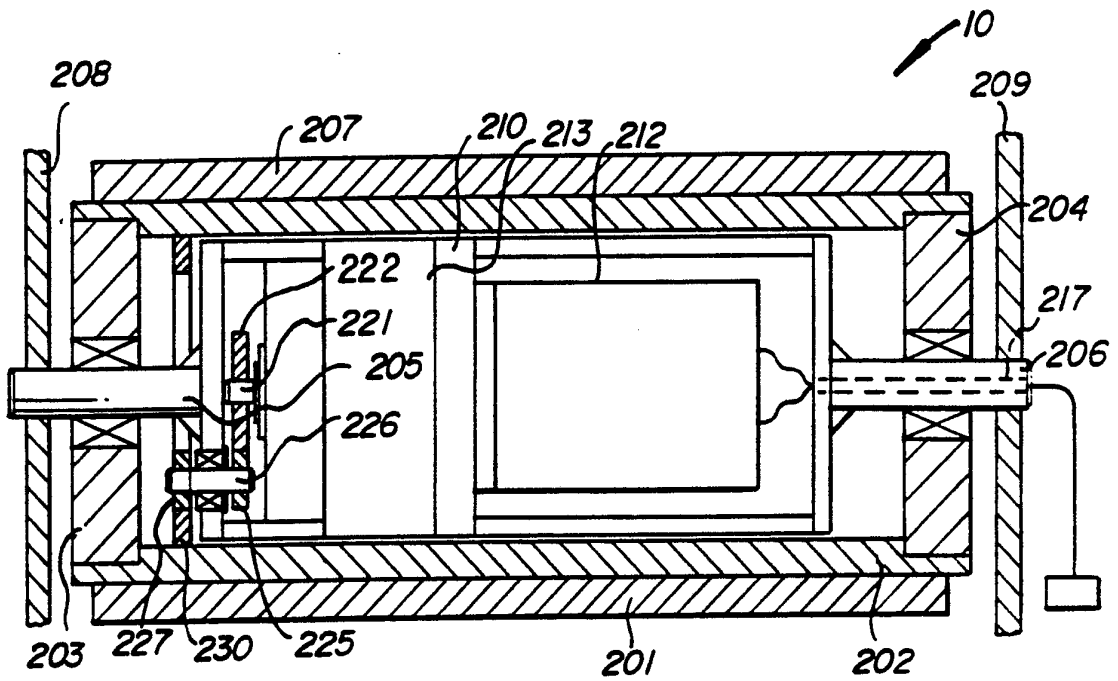

Fig. 15