

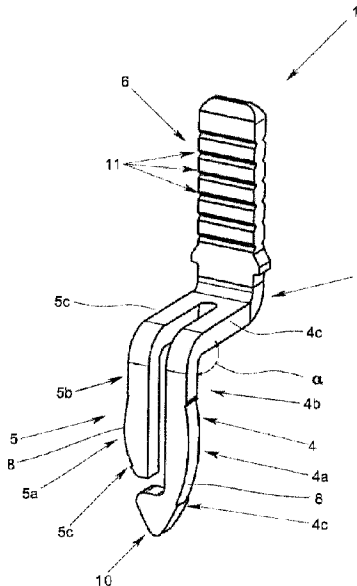

(86) Date de dépôt PCT/PCT Filing Date: 2017/04/21
 (87) Date publication PCT/PCT Publication Date: 2017/10/26
 (45) Date de délivrance/Issue Date: 2020/12/22
 (85) Entrée phase nationale/National Entry: 2018/10/19
 (86) N° demande PCT/PCT Application No.: EP 2017/059524
 (87) N° publication PCT/PCT Publication No.: 2017/182633
 (30) Priorité/Priority: 2016/04/22 (DE10 2016 107 482.9)

(51) Cl.Int./Int.Cl. *H01R 12/51* (2011.01),
H01R 12/58 (2011.01)
 (72) Inventeur/Inventor:
GESKE, RALF, DE
 (73) Propriétaire/Owner:
PHOENIX CONTACT GMBH & CO. KG, DE
 (74) Agent: BORDEN LADNER GERVAIS LLP

(54) Titre : CONTACT ENFICHABLE
 (54) Title: PLUG CONTACT



(57) **Abrégé/Abstract:**

The invention relates to a plug contact (1) for electrically contacting a printed circuit board (2) by plugging the plug contact (1) into a contact hole (3) of the printed circuit board (2), comprising two contact limbs (4, 5) which are elastic relative to each other, a terminal region (6), and a connection region (7). The connection region (7) connects the two contact limbs (4, 5) together and to the terminal region (6), and the plug contact (1) is punched out of a flat metal material and is bent. The plug contact (1) according to the invention ensures multiple plugging and pulling cycles without the inner wall (9) of the contact hole (3) being damaged in that each of the two contact limbs (4, 5) has a contacting region (4a, 5a) which contacts the contact hole (3) in the plugged-in state. The outer contour (8) of each of the two contact limbs (4, 5) has the shape of a segment of a circle in a cross-sectional view in the contacting region (4a, 5a), and the radius of the outer contour (8) is smaller than the radius of the corresponding contact hole (3) of the printed circuit board (2).

ABSTRACT

The invention relates to a plug contact (1) for electrically contacting a printed circuit board (2) by plugging the plug contact (1) into a contact hole (3) of the printed circuit board (2), comprising two contact limbs (4, 5) which are elastic relative to each other, a terminal region (6), and a connection region (7). The connection region (7) connects the two contact limbs (4, 5) together and to the terminal region (6), and the plug contact (1) is punched out of a flat metal material and is bent. The plug contact (1) according to the invention ensures multiple plugging and pulling cycles without the inner wall (9) of the contact hole (3) being damaged in that each of the two contact limbs (4, 5) has a contacting region (4a, 5a) which contacts the contact hole (3) in the plugged-in state. The outer contour (8) of each of the two contact limbs (4, 5) has the shape of a segment of a circle in a cross-sectional view in the contacting region (4a, 5a), and the radius of the outer contour (8) is smaller than the radius of the corresponding contact hole (3) of the printed circuit board (2).

PLUG CONTACT

The invention relates to a plug contact for making electrical contact with a circuit board by plugging the plug contact into a contact hole of the circuit board, with two contact legs which are resilient relative to one another, one terminal region and one connecting region, the connecting region connecting the two contact legs to one another and to the terminal region, and the plug contact being made from a metallic flat material.

In addition, the invention relates to an electrical supply terminal with a housing, with a conductor terminal element and with a conductor bar piece, a conductor which is to be connected being connectable in an electrically conductive manner to the conductor bar piece by means of the conductor terminal element and in the housing a conductor entry opening being made for entry of an electrical conductor which is to be connected.

Plug contacts for producing electrical connections between conductors, different electrical or electronic components and conductor bars are known in various embodiments and for various applications. For this purpose the plug contacts are plugged into corresponding receiving contacts or socket elements, and the receiving contacts can be for example openings in conductor bars. The plug contacts themselves can be connected to electrical components or can be designed for connection to electrical conductors, for which then the terminal region of the plug contacts is made accordingly.

For the connection between a circuit board and an electrical component or the connection of a conductor to a circuit board, there are various techniques, in practice mainly soldering and press-fitting having become established. Both techniques have proven themselves over the years since they ensure good and permanent electrical contact between the contact partners. One disadvantage both of soldering and press-fitting is that the two connecting techniques are not reversible, so that a connection, once established, cannot be broken again at all or can only be broken with increased effort. Moreover, to produce the connection additional working steps and/or special tools are necessary. Here plug-and-socket connections which have been used for decades in other applications offer one alternative, since the connection can be easily established by hand and moreover can also be disconnected again if necessary, and is therefore reversible.

Electrical supply terminals have also been known for decades in a host of versions. The supply terminals can be made for example for connecting one electrical conductor or several conductors to a circuit board as a so-called printed board terminal, for which the supply terminals can have corresponding contact pins which can be soldered or press-fitted into the corresponding holes in the circuit board. The conductor terminal element can be for example a tension sleeve which is part of a screw terminal and by which a conductor which is to be connected can be joined in an electrically conductive manner to the conductor bar piece. Likewise the conductor terminal element can also be made as a crimp terminal to which the stripped end of a conductor to be connected can be attached, the crimp terminal then being made on one end of the conductor bar piece and the contact pin being made on the other end of the conductor bar piece. An insulation piercing terminal in which one insulated end of a conductor is forced into the cutting edges of the insulation piercing terminal is also possible as a conductor terminal element.

Conductor terminal elements can moreover also be clamping springs, both loop-shaped clamping springs, so-called tension spring clamps, and also U-shaped or V-shaped clamping springs being used. Rigid conductors or conductors provided with a wire end ferrule can be plugged directly, i.e. without the clamping site having to be opened beforehand with a tool, into U-shaped or V-shaped clamping springs. In the known U-shaped or V-shaped clamping springs the conductor which is to be connected is forced by the clamping leg of the clamping spring against the conductor bar piece, as a result of which the electrical connection between the conductor and the conductor bar piece is established. To connect flexible conductors the clamping site between the clamping leg and the conductor bar piece must be opened, for which in the housing an actuating opening is made for insertion of a tool, for example the tip of a screwdriver. The actuating opening is also used to open the clamping site in order to be able to pull a connected conductor out of the clamp again.

For some time a plug contact which has been made for use in circuit boards has been known from practice; it is made in the manner of spring fork and has two flat contact legs which are resilient relative to one another and which are joined to one another via a common connecting region. The plug contact is punched out of a metallic flat material and bent, to produce the two contact legs a region as narrow as possible being punched out between the contact legs. In the plugged-in state the contact legs with their two outer edges each press against the inside wall of the contact hole into which

the plug contact has been plugged. The terminal region which is opposite the contact legs is made as a crimp terminal so that one conductor at a time can be connected to one plug contact.

A supply terminal with several of the above described plug contacts is known from DE 10 2011 011 017 A1. The individual plug contacts are arranged in several rows next to one another in chambers of the terminal housing such that the plug contacts extend perpendicular to the plane of the circuit board. To connect individual conductors, the terminal regions are made as a crimp terminal for the individual plug contacts. In this way several conductors can be connected to one circuit board in which the individual contact holes have a short distance to one another.

A fork-shaped plug contact for making contact with a circuit board is also known from DE 202 18 295 U1. In this plug contact the contact legs with their punching edges also press against the inside wall of the contact hole, the two contact legs each having two outside edges which when the plug contact is being forced into the contact hole of the circuit board are buried in the metal coating of the wall of the hole. Preferably cold welds between the metal coating of the wall of the hole and the contact legs will occur in order to ensure good electrical contact. But it is a disadvantage here that the sharp edges of the contact legs can damage the inside wall of the contact hole in the process of plugging in so that a coating, for example of tin, which has been applied in the contact hole, is worn away after a few cycles.

The aspect of this invention is to make available the initially described plug contact which even for several plug-in cycles enables reliable and good contact-making with the contact hole so that the plug-in connector ensures good and permanent electrical contact between the contact partners. Moreover an electrical supply terminal will be devised with which an electrical conductor can be easily connected to a circuit board.

This aspect is achieved in the initially described plug contact by the two contact legs each having a contact-making region which makes contact with the contact hole in the plugged-in state, the outside contour of the two contact legs in the contact-making region each being made in the shape of a circular segment in cross section. The outside contour of the contact legs is thus machined in particular in the region in which the contact legs in the plugged-in state make contact with the contact hole such that it has no sharp edges which are buried in the metal coating of the wall of the hole when

the plug contact is plugged into the contact hole. This makes it possible to repeatedly plug in and unplug the plug contact without damaging the inside wall of the contact hole in the circuit board.

The outside contour of the contact legs which is circular segment-shaped in cross section has a radius which is smaller than the radius of the contact hole. Advantageously this leads to only one linear contact between the contact legs and the contact hole, instead of two linear contacts, as in the plug contacts known from the prior art in which the two contact legs make contact with the contact hole each with their two outer edges.

According to one especially preferred configuration of the plug contact as claimed in the invention, the outside contour of the two contact legs in the contact-making region is made in the shape of a circular segment not only in cross section, but in the longitudinal direction, so that the contact-making regions of the two contact legs are made crowned. The two contact legs in the contact-making region both in the plug-in direction of the contact legs and also perpendicular to the plug-in direction have a rounded outside contour so that there is only essentially one spot contact between the contact legs and the contact hole in the contact-making region.

The crowned shape of the contact-making regions can be easily produced using a die into which the contact-making regions of the contact legs are forced after punching the plug contact out of the metallic flat material or which is pressed against the contact legs. This stamping or shaping of the outside contour of the contact legs which has been produced by punching out moreover has the advantage that in doing so the roughness of the outside edges of the contact legs produced during punching are smoothed, further reducing the risk of damage of a coating which has been applied on the inside wall of one contact hole. Finally, the desired crowning of the outside contour of the contact legs can be easily produced by the stamping, and the radii of the outside contour of the contact-making regions can be dictated by the shape of the die which is being pressed against the outside of the contact legs. Preferably the radius of the circular segment-shaped outside contour in the longitudinal direction is greater than the radius of the circular segment-shaped outside contour in cross section.

According to one preferred configuration of the invention the two contact legs have different lengths, i.e. there are a first longer contact leg and a second shorter contact leg. On the free end of the longer contact leg a guide segment is formed which in the plug-in direction of the plug contact is located upstream of the free end of the shorter contact leg. The guide segment is used here as an

insertion and centering aid when the plug contact is being plugged into the corresponding contact hole in a circuit board. For this purpose the guide segment on its side facing away from the connecting region and thus facing the contact hole when being plugged in has a wedge-shaped or semicircular outside contour. When the plug contact is being plugged into the contact hole thus the guide segment of the first longer contact leg slides first into the contact hole before the second shorter contact leg also dips into the contact hole, the two contact legs then being forced onto one another by the contact wall of the contact hole as plugging-in proceeds so that the distance between the two contact legs is reduced compared to the unplugged state.

In a first version of the plug contact as claimed in the invention the two contact legs extend in one plane, the direction of primary extension of the plug contact running parallel to the plug-in direction. According to a second version of the plug contact the two contact legs are bent at an angle, the two contact legs each having a first region and a second region which are located at an angle α to one another. Preferably the angle α between the two regions of the contact legs is roughly 90° so that the contact legs are bent roughly L-shaped. The respectively first region of the two contact legs is connected to the connecting region, while the contact-making regions are made on the second regions and the ends of the second regions form the free ends of the contact legs with which the contact legs are plugged forward into the corresponding contact hole in the circuit board.

The angling of the contact legs reduces the overall height of the plug contact. Moreover a plug contact with angled contact legs has the advantage that the working region of the plug contact which is active when the contact legs are plugged into the contact hole, i.e. the region which produces the reset force of the plug contact, lies essentially in the first region of the contact legs. In this region the contact legs are loaded primarily in torsion and not bending; this leads to the plug contact being more elastic compared to a plug contact with straight contact legs which are not angled. The plug contact can thus be more easily plugged into a contact hole or pulled out of the contact hole again.

Regardless of whether the two contact legs are bent or extend in one plane, there are various possibilities for how the terminal region of the plug contact as claimed in the invention can be made. According to a first version the terminal region is made as a crimp terminal by means of which the stripped end of a conductor to be connected can be electrically connected. Alternatively the terminal region can also be made as an insulation piercing terminal so that the terminal region has two cutting

edges opposite one another between which the insulated end of a conductor to be connected is forced so that the cutting edges penetrate the insulation of the conductor and make contact with the metal conductor.

According to another preferred configuration of the plug contact as claimed in the invention, the terminal region is made as a flat conductor bar which together with a tension sleeve forms a screw terminal or together with a clamping spring forms a spring force clamping terminal. In order to increase the surface pressure between the plugged-in conductor and the conductor bar, preferably several grooves or notches are made on the side of the conductor bar facing the conductor, as a result of which the contact resistance between the conductor and the current bar is reduced.

The initially named aspect is achieved in the electrical supply terminal. The electrical supply terminal has a plug contact as claimed in the invention which is located at least partially in the housing of the supply terminal such that the conductor bar piece is formed by the terminal region of the plug contact, and the contact legs of the plug contact with their contact-making regions protrude out of the bottom of the housing. The bottom of the housing is considered the side which is facing the circuit board when the supply terminal is being mounted on the circuit board. With respect to the advantages of the electrical supply terminal as claimed in the invention, reference is made to the above statements in conjunction with the plug contact as claimed in the invention.

To connect a conductor to the supply terminal, different connecting techniques can be used, i.e. the plug contact as claimed in the invention can be used in supply terminals with different connecting techniques or different conductor terminal elements. According to one preferred configuration, the conductor terminal element is a clamping spring which has one clamping leg and one contact leg, the clamping leg together with the terminal region of the plug contact forming a spring force clamping terminal for the conductor which is to be connected. The use of a clamping spring as a conductor terminal element has the additional advantage that a conductor to be connected via the spring force clamping terminal can be very easily connected to the supply terminal and thus also to the circuit board. If necessary the electrical conductor can moreover also be pulled out of the supply terminal again when the spring force clamping terminal is being opened. The electrical connection between the conductor and the circuit board can thus be disconnected both between the

conductor and the terminal region of the plug contact and also between the contact legs of the plug contact and the circuit board.

According to one alternative configuration the electrical supply terminal can for example also be made as a screw terminal so that in the housing there is a tension sleeve which together with the terminal region of the plug contact which is made for this purpose as a flat conductor bar forms a screw terminal for the conductor which is to be connected. The tension sleeve is actuated using a screw which is accessible via an actuating opening in the housing of the supply terminal. Alternatively the conductor terminal element can also be made as a crimp terminal to which the stripped end of a conductor which is to be connected can be attached.

If in the electrical supply terminal the terminal region extends in the longitudinal direction of the contact legs, the conductor entry opening is located on the top of the housing and an electrical lead which is to be connected is plugged into the supply terminal perpendicular to the plane of the circuit board. But in addition it is also possible for the terminal region of the plug contact to be bent perpendicular or at an angle not equal to 90° to the longitudinal direction of the contact legs so that the conductor entry opening is then located accordingly on one front side of the housing.

According to another advantageous configuration, for simple mounting of the electrical supply terminal on a circuit board it is provided that on the bottom of the housing several adjusting elements are made which when the supply terminal is being mounted on the circuit board are inserted into corresponding recesses in the circuit board. The ends of the adjusting elements are made preferably conical; this facilitates the insertion of the adjusting elements into the corresponding recesses in the circuit board. Moreover the length of the adjusting elements is chosen in such a way that when the supply terminal is being mounted on the circuit board first the adjusting elements with their free ends engage the corresponding recesses in the circuit board before the contact-making regions of the contact legs of the plug contact dip into the corresponding contact holes in the circuit board.

According to another configuration of the electrical supply terminal as claimed in the invention, in addition to the adjusting elements at least two locating elements are made on the bottom of the housing and engage corresponding recesses in the circuit board. Corresponding locating projections or locating lugs can ensure that the electrical supply terminal after mounting on a circuit

board is reliably fastened to the latter. Preferably the locating elements are made such that they can be shifted out of a first nonlatching state into a second latching state and vice versa. In this way it is possible to release the latching between the housing of the electrical supply terminal and the circuit board again so that the electrical supply terminal can also be lifted off the circuit board again.

In particular there is at this point a host of possibilities for configuring and developing the plug contact as claimed in the invention and the electrical supply terminal as claimed in the invention. For this purpose reference is made to the following description in conjunction with the drawings which show the following.

Figure 1 shows a perspective representation of one exemplary embodiment of a plug contact as claimed in the invention,

Figure 2 shows an extract of a circuit board with a plug contact inserted into a contact hole according to Figure 1,

Figure 3 shows an enlarged detail of a contact leg plugged into a contact hole, in cross section,

Figure 4 shows two alternative exemplary embodiments of the plug contact according to Figure 1,

Figure 5 shows one version each of the two plug contacts shown in Figure 4,

Figure 6 shows one exemplary embodiment of an electrical supply terminal as claimed in the invention, in cross section,

Figure 7 show two representations of the plug contact according to Figure 1 with two different conductor terminal elements, and

Figure 8 shows one version each of the two plug contacts shown in Figure 7, with two different conductor terminal elements.

Figures 1 and 2 show a plug contact 1 for making contact with a circuit board 2, for which the plug contact 1 is plugged into a corresponding contact hole 3 in the circuit board 2. The plug contact 1 which is punched out of a metallic flat material and bent has two contact legs 4, 5 which are resilient relative to one another, one terminal region 6 and one connecting region 7, the two contact legs 4, 5 being connected to one another and to the terminal region 6 via the connecting region 7.

The contact legs 4, 5 each have one contact-making region 4a, 5a which makes contact with the contact hole 3 in the plugged-in state according to Figure 2, the outside contour 8 of the two

contact legs 4, 5 in the contact-making region 4a, 5a each being made in the shape of a circular segment in cross section, as is apparent according to Figure 3 from the enlarged cross section of one contact leg 4 plugged into a contact hole 3. Here it is also apparent that the radius of the outside contour 8 of the contact leg 4 is somewhat smaller than the radius of the contact hole 3 so that when the contact legs 4, 5 are plugged into the contact hole 3 the inside wall 9 of the contact hole 3 is not damaged. This leads to a plug contact 1 which has been made in this way enabling clearly more plugging and unplugging cycles than a plug contact in which the outside contour of the contact legs is straight in cross section. In a plug contact whose contact legs have a straight outside contour in the contact-making region, after a few plugging-in cycles grooves form in the inside wall 9 of the contact hole 3 so that the surface of the inside wall 9 of the contact hole 3 is damaged, in particular when it has a coating.

Figures 1 and 2 moreover show that the outside contour 8 of the two contact legs 4, 5 in the contact-making region 4a, 5a is also made in the shape of a circular segment in the longitudinal direction so that the contact-making regions 4a, 5a are made crowned. The contact-making regions 4a, 5a thus make contact with the inside wall 9 of the contact hole 3 only with their center region so that ideally there is only one spot contact between the contact legs 4, 5 and the contact hole 3. In practice this theoretical spot contact becomes larger due to the surface pressure between the contact legs 4, 5 and the inside wall 9 of the contact hole 3 on small essentially circular surfaces. Since the contact-making regions 4a, 5a do not have sharp edges which touch the inside wall 9 of the contact hole 3 due to the crowned execution, damage to the inside wall 9 of the contact hole 3 when the plug contact 1 is being plugged in and unplugged is avoided. For this reason there remains a coating for example of tin applied to the inside wall 9, even after several plugging and unplugging cycles of the plug contact 1 as claimed in the invention.

In the exemplary embodiments of the plug contact 1 as claimed in the invention which are shown in the figures, the two contact legs 4, 5 have different lengths, on the free end 4b of the longer contact leg 4 a guide segment 10 being located which in the plug-in direction E of the plug contact 1 is located upstream of the free end 5b of the shorter second contact leg 5. The guide segment 10 is used here as an insertion and centering aid when the plug contact 1 is being plugged into the corresponding contact hole 3 of a circuit board 2. For this purpose the guide segment 10 on its side

which faces away from its terminal region 6 and which faces the contact hole 3 when being plugged in has a wedge-shaped outside contour which dips first into the contact hole 2 when the plug contact 1 is being plugged in.

In the exemplary embodiments of the plug contact 1 as claimed in the invention which are shown in Figures 1, 2, 4 and 7, the two contact legs 4, 5 each have a first region 4c, 5c and a second region 4b, 5b which are located at an angle α to one another. The angle α in the exemplary embodiments shown in the figures is roughly 90° so that the two contact legs 4, 5 are bent roughly L shaped. The first two regions 4c, 5c of the contact legs 4, 5 which run horizontally in the alignment shown in the figures, connect to the connecting region 7, while the ends of the two second regions 4d, 5d form the free ends 4b, 5b of the contact legs 4, 5. The contact-making regions 4a, 5a are made on the second regions 4d, 5d, the width of the plug contact 1 being greatest in the zone of the contact-making regions 4a, 5a so that in the plugged-in state of the plug contact 1 the two contact legs 4, 5 are bent at maximum onto one another so that the normal contact force between the contact legs 4, 5 and the contact hole 3 is also maximum.

The plug contact 1 which is shown in Figures 1 and 2 differs from the two versions of the plug contact 1 which are shown in Figures 4 by a different configuration of the terminal region 6. While in the embodiment shown in Figures 1 and 2 the terminal region 6 is made as a flat conductor bar 6', the terminal region 6 in the exemplary embodiment according to Figure 4a is made as a crimp terminal 6'' and in the exemplary embodiment according to Figure 4b as an insulation piercing terminal 6'''. In order to increase the surface pressure between a connected conductor and the conductor bar 6', the latter on the side facing the conductor has several grooves 11. Depending on the type of execution of the terminal region 6 an electrical conductor can thus be electrically connected to the plug contact 1 in different ways.

Figure 5 shows one version each of the two plug contacts 1 shown in Figure 4, in which the two contact legs 4, 5 of the plug contact 1 are not bent, but extend in one plane. In the plug contact 1 according to Figure 5a the terminal region 6 - corresponding to the plug contact 1 according to Figure 4a - is made as a crimp terminal 6'', while in the plug contact 1 according to Figure 5b - corresponding to the plug contact 1 according to Figure 4b - the terminal region 6 is made as an insulation piercing

terminal 6". The possible execution of the terminal region 6 is thus independent of whether the contact legs 4, 5 are bent or extend in one plane.

Figure 6 shows one preferred exemplary embodiment of an electrical supply terminal 12 as claimed in the invention which has a housing 13 which generally consists of plastic. In the housing 13 there are several conductor entry openings 14 and a corresponding number of plug contacts 1, the contact legs 4, 5 of the individual plug contacts 1 protruding with their contact-making regions 4a, 5a out of the bottom 15 of the housing 13 facing a circuit board 2.

In the illustrated exemplary embodiment, in the housing 13 of the supply terminal 12 there are moreover a number of clamping springs 16 corresponding to the number of plug contacts 1 as conductor terminal elements which each have one clamping leg 17 and one contact leg 18. Here each clamping spring 16 is assigned one plug contact 1 such that the terminal region 6 of one plug contact 1 made as a flat conductor bar 6' together with the free end of the clamping leg 17 of the clamping spring 16 forms a spring force clamping terminal for an electrical conductor which has been inserted into the housing 13 through a conductor entry opening 14. Since the supply terminal 12 is designed for connection of five conductors, in the housing 13 accordingly five conductor entry openings 14 are also made. To open the individual spring force clamping terminals, there are moreover five actuating pushers 19 movably located in the housing 13. If one actuating pusher 19 is forced into the interior of the housing 13, the actuating pusher 19 deflects the clamping leg 17 of the clamping spring 16 against its spring force so that the clamping site is opened and thus a connected conductor can be pulled out of the clamping site. If the clamping site is opened using the actuating pusher 19, a flexible conductor can moreover also be inserted into the clamping site.

Alternatively to the configuration shown in Figure 6 with one clamping spring 16 as a conductor terminal element, the supply terminal 12 can also have a tension sleeve 20 as a conductor terminal element which together with the terminal region 6 of one plug contact 1 forms a screw terminal for an electrical conductor which is to be connected. These two possible alternative types of terminals - spring force clamping terminal and screw terminal - are shown in Figures 7 and 8, there only one plug contact 1 at a time together with one clamping spring 16 (Figures 7a and 8a) or with one tension sleeve 20 (Figures 7b and 8b) being shown, therefore without the housing which accommodates the plug contact 1 and the respective conductor terminal element. Figure 7 shows two

plug contacts 1 according to Figures 1 and 2, in which the two contact legs 4, 5 each are bent L-shaped. In contrast, in the two exemplary embodiments according to Figure 8 the plug contacts 4, 5 are not bent, but extend continuously in one plane, specifically in the plug-in direction E. The screw terminal which is shown in Figures 7b and 8b moreover has another screw 21 with which the screw terminal can be actuated so that the stripped end of the conductor which has been inserted into the tension sleeve 20 is pulled by means of the tension sleeve 20 against the conductor bar 6'.

To fasten the housing 13 of the electrical supply terminal 12 on a circuit board 2, on the bottom 15 of the housing 13 several adjusting elements 22 located offset to one another are made which each project over the bottom 15 of the housing 13 and can be inserted into corresponding recesses in a circuit board 2. Moreover on the housing 13 suitable latching elements with which the housing 13 can be latched on a circuit board can also be made.

CLAIMS:

1. A plug contact for making electrical contact with a circuit board by plugging the plug contact into a contact hole of the circuit board, with two contact legs which are resilient relative to one another, a terminal region and a connecting region, the connecting region connecting the two contact legs to one another and to the terminal region and the plug contact being made from a metallic flat material,

wherein

the two contact legs each have a contact-making region which make contact with the contact hole in the plugged-in state, and

the outside contour of the two contact legs in the contact-making region is made circular segment-shaped in cross section,

wherein

the radius of the outside contour being made smaller than the radius of the corresponding contact hole of the circuit board the outside contour of the two contact legs in the contact-making region is made circular segment-shaped in the longitudinal direction so that the contact-making regions are made crowned, and

wherein the radius of the circular segment-shaped outside contour in the longitudinal direction is greater than the radius of the circular segment-shaped outside contour in cross-section.

2. The plug contact as claimed in Claim 1, wherein the two contact legs have different lengths, on the free end of the longer contact leg a guide segment being made which is located in the plug-in direction of the plug contact upstream of the free end of the shorter contact leg.

3. The plug contact as claimed in any one of Claims 1 to 2, wherein the two contact legs each have a first region and a second region which are located at an angle to one another so that the two contact legs are bent roughly L-shaped, the two first regions connecting to the connecting region and the contact-making regions being made on the second regions.

4. The plug contact as claimed in any one of Claims 1 to 3, wherein the terminal region is

made as a flat conductor bar.

5. The plug contact as claimed in claim 4, wherein the flat conductor bar includes grooves on one side.

6. The plug contact as claimed in claim 4, wherein the flat conductor bar includes notches on one side.

7. The plug contact as claimed in any one of Claims 1 to 3, wherein the terminal region is made as a crimp terminal or as an insulation piercing terminal.

8. An electrical supply terminal with a housing, with a conductor terminal element and with a conductor bar piece, a conductor which is to be connected being connectable in an electrically conductive manner to the conductor bar piece by means of the conductor terminal element and in the housing a conductor entry opening being made for entry of an electrical conductor which is to be connected,

wherein

a plug contact as claimed in any one of Claims 1 to 7 is located in the housing such that the conductor bar piece is formed by the terminal region of the plug contact and the contact legs with their contact-making regions protrude from the bottom of the housing facing a circuit board.

9. The electrical supply terminal as claimed in Claim 8, wherein the conductor terminal element is a clamping spring in the housing, the clamping spring having one clamping leg and one contact leg and the clamping leg with the terminal region of the plug contact forming a spring force clamping terminal for an electrical conductor which is to be connected.

10. The electrical supply terminal as claimed in Claim 8, wherein as the conductor terminal element in the housing there is a tension sleeve which together with the terminal region of the plug contact forms a screw terminal for an electrical conductor which is to be connected.

11. The electrical supply terminal as claimed in any one of Claims 8 to 10, wherein on the bottom of the housing several adjusting elements are made for insertion into corresponding recesses in a circuit board.

1/8

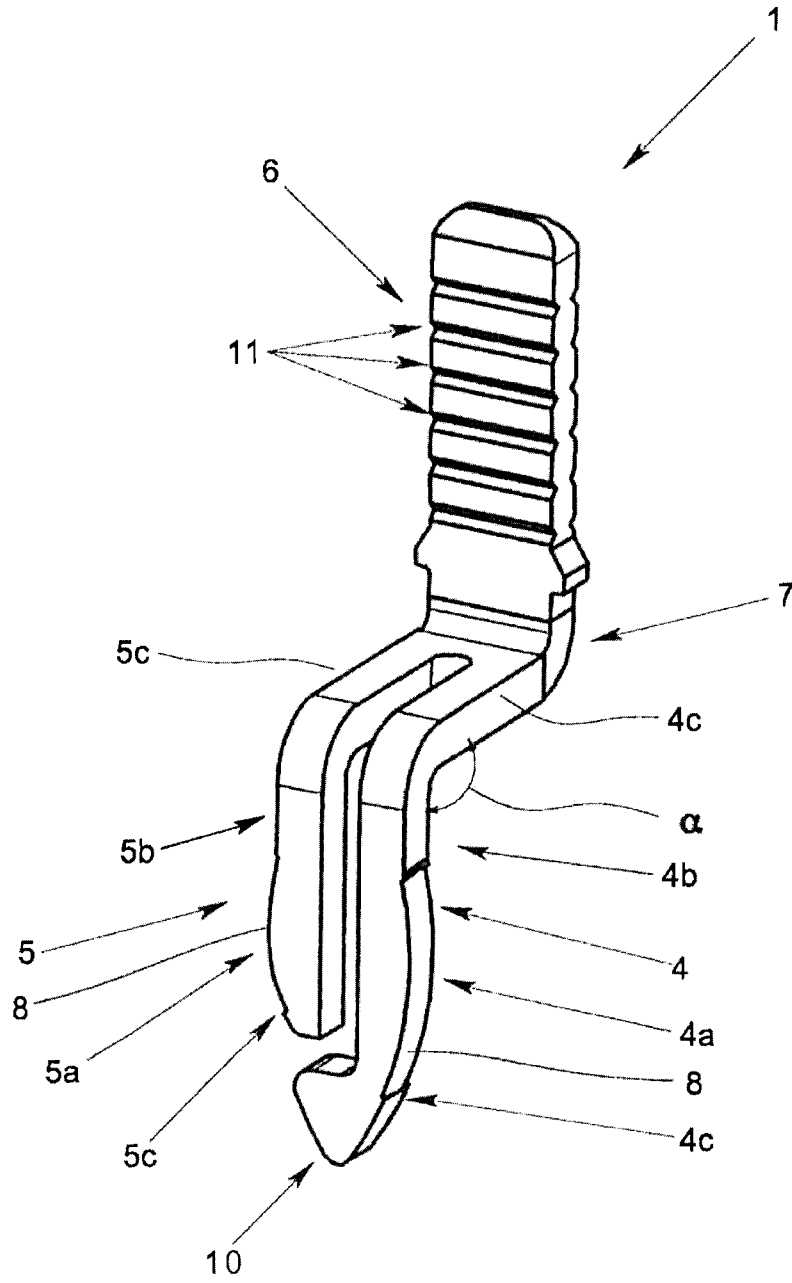

Fig. 1

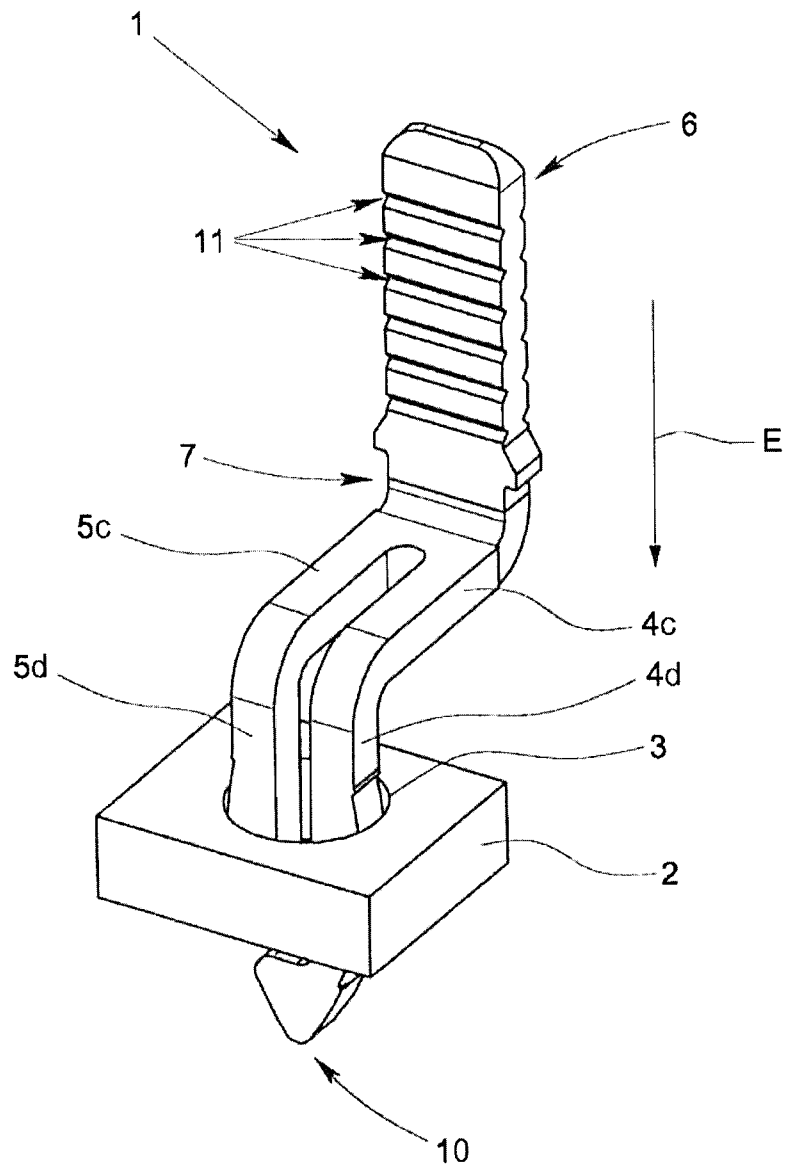

Fig. 2

3/8

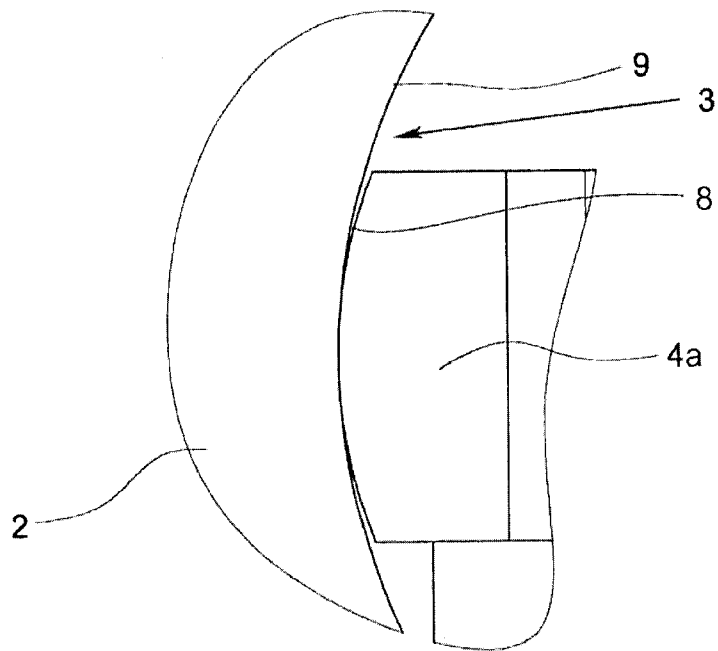

Fig. 3

4/8

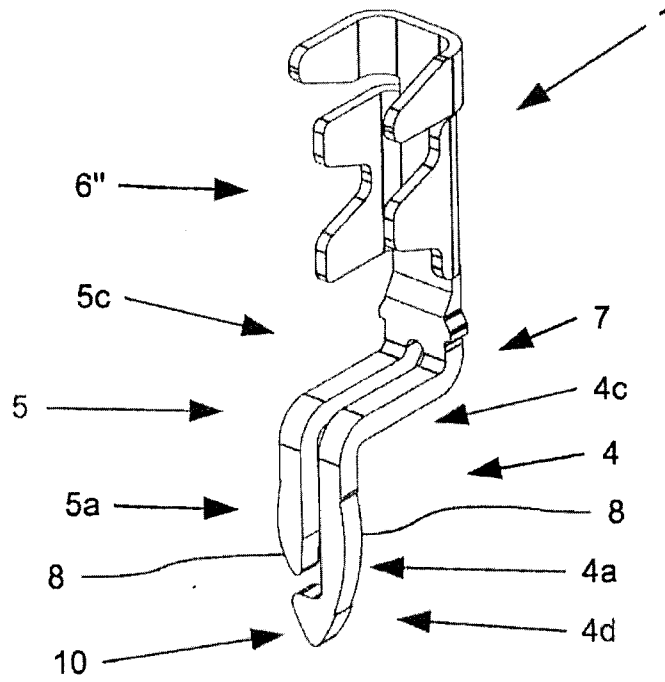

Fig. 4a

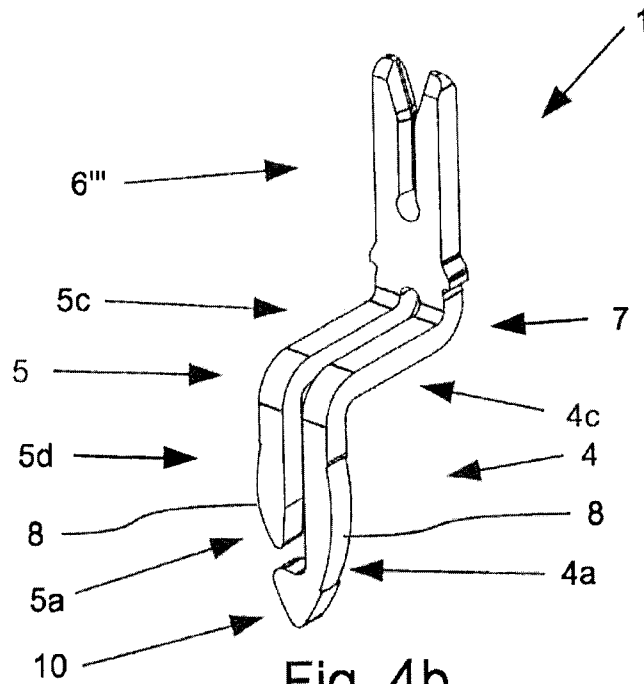

Fig. 4b

5/8

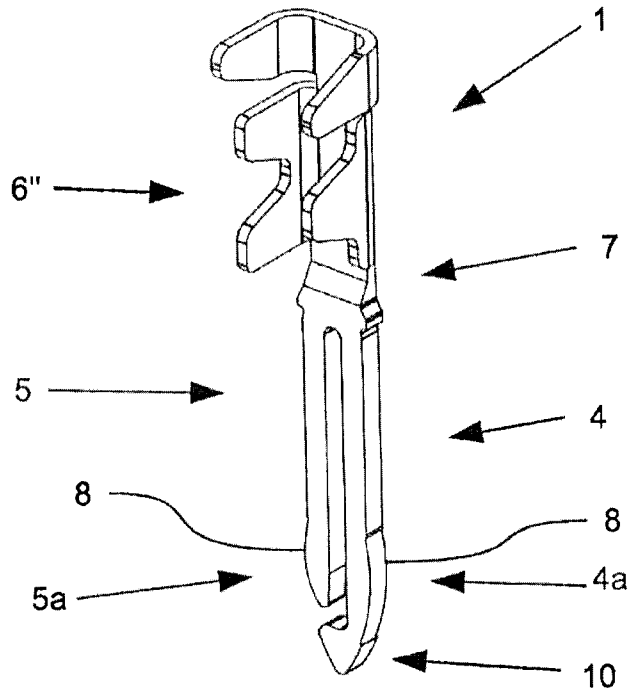

Fig. 5a

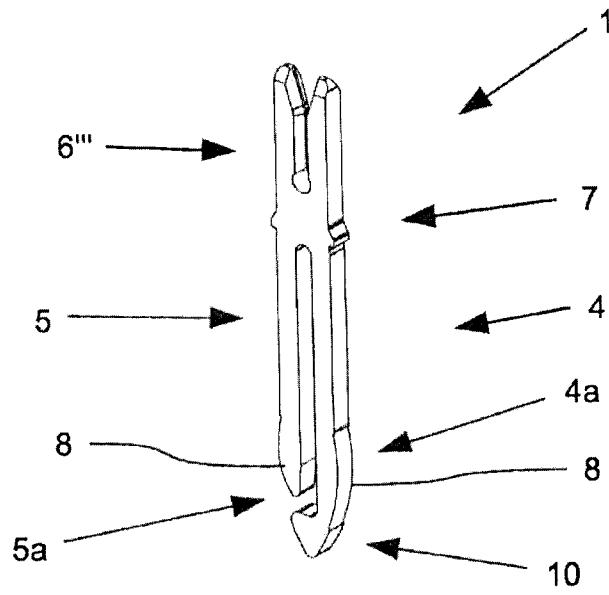

Fig. 5b

6/8

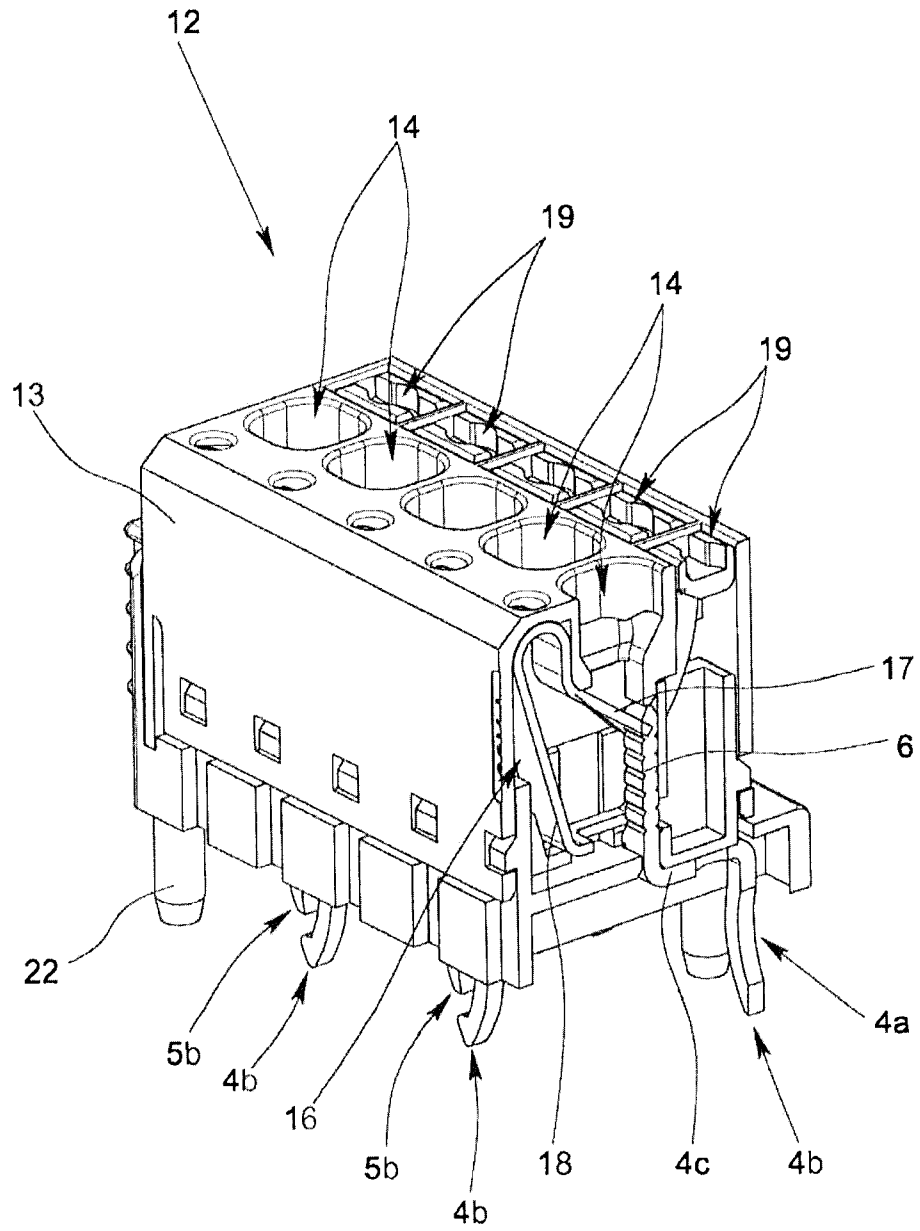

Fig. 6

7/8

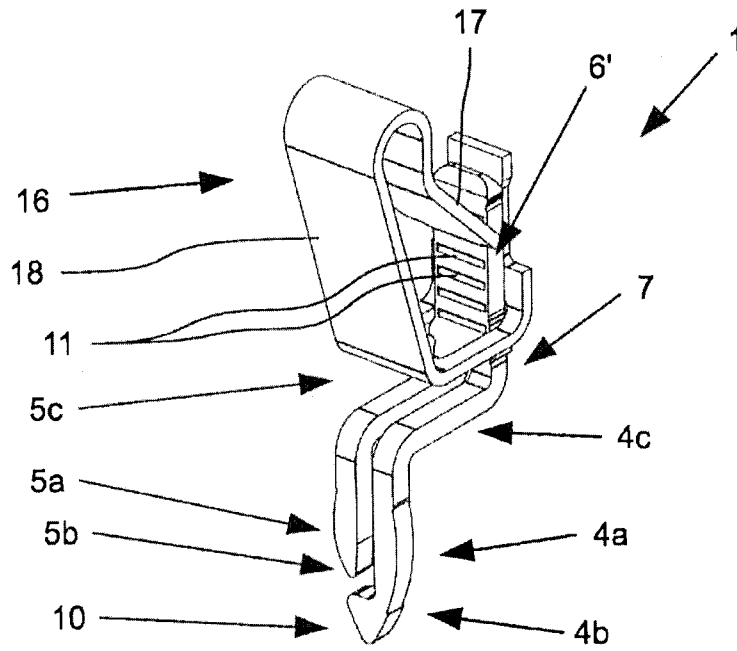

Fig. 7a

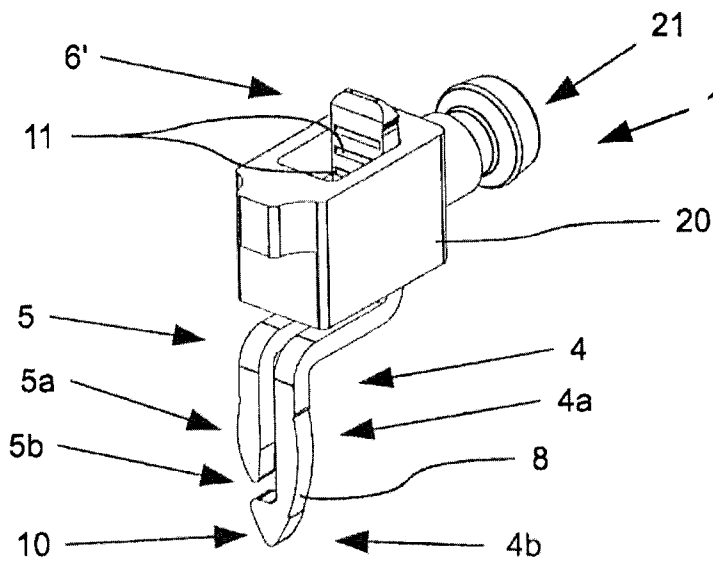

Fig. 7b

8/8

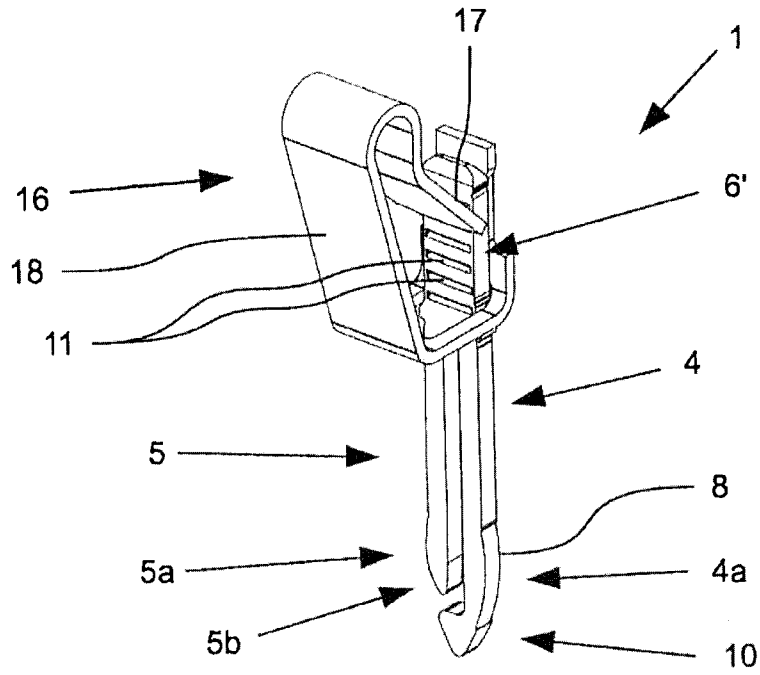

Fig. 8a

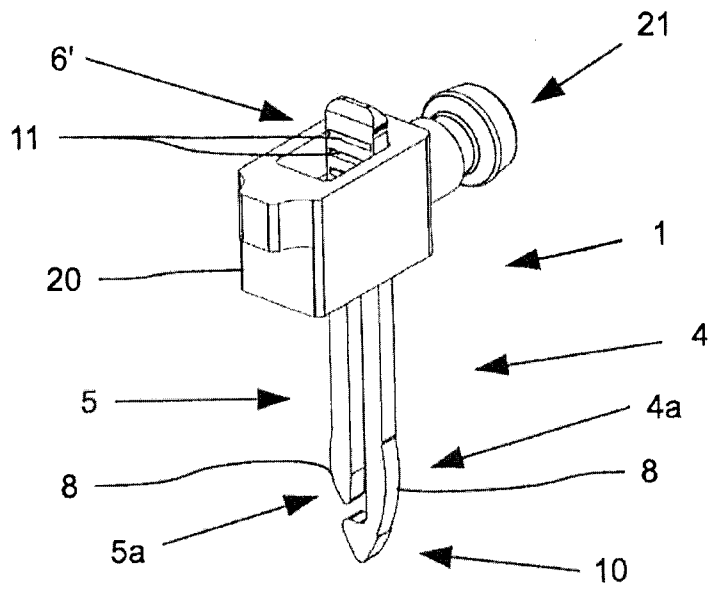

Fig. 8b

