

E. A. RICE.

Improvement in Adjustable-Back for Carriage-Seats.

No. 128,171.

Patented June 18, 1872.

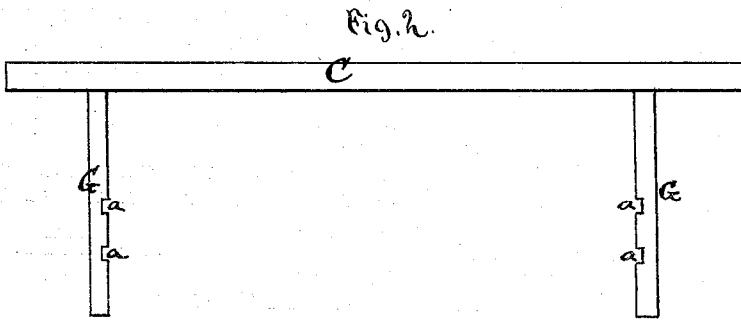
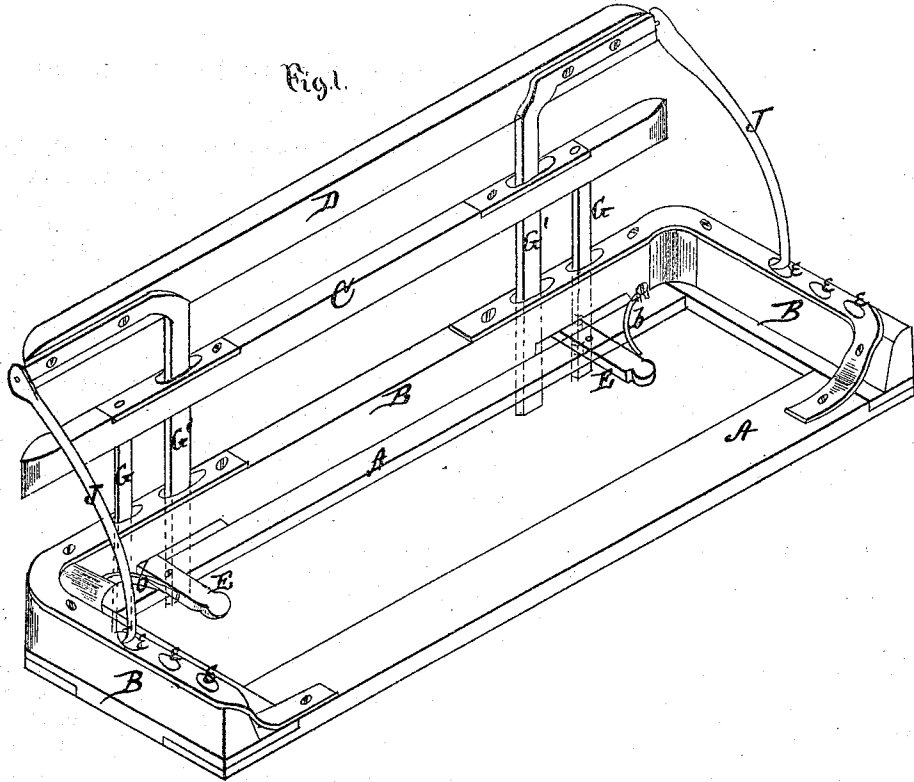

Witnesses

*W. S. Newman*  
*C. L. Evers*

Inventor

*Everett A. Rice*  
per *Alexander Mason*  
Attorneys

# UNITED STATES PATENT OFFICE.

EVERETT A. RICE, OF WILMINGTON, VERMONT.

## IMPROVEMENT IN ADJUSTABLE BACKS FOR CARRIAGE-SEATS.

Specification forming part of Letters Patent No. 128,171, dated June 18, 1872.

*To all whom it may concern:*

Be it known that I, EVERETT A. RICE, of Wilmington, in the county of Windham and in the State of Vermont, have invented certain new and useful Improvements in Adjustable Backs for Buggies and Carriage-Seats; and do hereby declare that the following is a full, clear, and exact description thereof, reference being had to the accompanying drawing and to the letters of reference marked thereon making a part of this specification.

The nature of my invention consists in the construction and arrangement of an "adjustable back for buggy and other carriage-seats," as will be hereinafter more fully set forth.

In order to enable others skilled in the art to which my invention appertains to make and use the same, I will now proceed to describe its construction and operation, referring to the annexed drawing, in which—

Figure 1 is a perspective view of a buggy or carriage seat with my adjustable back attached to it, and Fig. 2 is a detached view of a part of the adjustable back.

A represents the seat of a buggy or carriage, and provided, as is usual in no-back seats, with a rim, B, extending around the rear side and ends. C and D represent the rails which form the back. The rail C is provided, near or at suitable distance from each end, with a downward-projecting metal bar, G, which passes through a hole or mortise in the rim B and seat A. The bars G G are provided with notches *a a* on their inner sides, as shown in Fig. 2, and are held by levers E E, which are pressed into said notches by springs *b b*. These levers are pivoted on the rear part of the seat A and pass through mortises made

in the lower edge of the rim B. The rail D is also provided with two downward-projecting bars, G' G', which pass through holes or mortises made in the rail C, as well as through the rim B and seat A. At the ends of this rail D are pivoted the arms J J, the front ends of which are hooked and fastened in holes *e e*, made in the upper front edges of the end pieces of the rim B. By changing the hooked ends of the arms J J in the holes *e e* the rail D may be raised and lowered to suit. The rail C is raised and lowered at will by the use of the spring-levers E E.

The seat, as well as the rails may be iron bound and finished in any desired manner; especially should the holes *e e* be formed in metal bars attached to the rim B.

Having thus fully described my invention, what I claim as new, and desire to secure by Letters Patent, is—

1. The rail C provided with two or more downward-projecting notched bars, G G, which are passed through mortises in the rim B of the seat and secured by the levers E E and springs *b b*, substantially as set forth.

2. The rail D provided with downward-projecting bars G' G', which pass through mortises in the rail C and rim B of the seat A, and the arms J J which are adjusted in the perforations *e e* in the rail B, all substantially as set forth.

In testimony that I claim the foregoing I have hereunto set my hand this 24th day of February, 1872.

EVERETT A. RICE.

Witnesses:

HENRY C. BOYD,  
J. R. BUELL.