

(19) **DANMARK**

(10) **DK/EP 2937159 T3**



(12)

Oversættelse af  
europæisk patentskrift

Patent- og  
Varemærkestyrelsen

- 
- (51) Int.Cl.: **B 21 K 5/16 (2006.01)**
- (45) Oversættelsen bekendtgjort den: **2017-05-15**
- (80) Dato for Den Europæiske Patentmyndigheds bekendtgørelse om meddelelse af patentet: **2017-02-15**
- (86) Europæisk ansøgning nr.: **14200639.4**
- (86) Europæisk indleveringsdag: **2014-12-30**
- (87) Den europæiske ansøgnings publiceringsdag: **2015-10-28**
- (84) Designerede stater: **AL AT BE BG CH CY CZ DE DK EE ES FI FR GB GR HR HU IE IS IT LI LT LU LV MC MK MT NL NO PL PT RO RS SE SI SK SM TR**
- (73) Patenthaver: **Chen, Ming-Chang, No. 128, Silin Road , Yanchao District, Kaohsiung City, Taiwan**  
**Liao, Mao-Chih, No. 23, Lane 58 , Weisui East Road , Gangshan District, Kaohsiung City, Taiwan**
- (72) Opfinder: **Chen, Ming-Chang, No. 128, Silin Road , Yanchao District, Kaohsiung City, Taiwan**  
**Liao, Mao-Chih, No. 23, Lane 58 , Weisui East Road , Gangshan District, Kaohsiung City, Taiwan**
- (74) Fuldmægtig i Danmark: **Plougmann Vingtoft A/S, Rued Langgaards Vej 8, 2300 København S, Danmark**
- (54) Benævnelse: **Fremgangsmåde til fremstilling af en skruenøgle**
- (56) Fremdragne publikationer:  
**EP-A1- 2 156 920**  
**FR-A1- 2 831 473**  
**US-A- 1 564 167**



# DESCRIPTION

## BACKGROUND OF THE INVENTION

### 1. Field of the Invention

[0001] This invention relates to a spanner shaping method and relates particularly to a method of making a spanner capable of reducing the waste of the material, shortening the processing time and decreasing the cost.

### 2. Description of the Related Art

[0002] Referring to Fig. 1 and Fig. 2, a traditional method 1 of making a spanner S1 is carried out by hot forging. The method 1 comprises a preparing step 11, a cutting step 12, a heating step 13, a punching step 14, a cooling step 15 and a removing step 16. The preparing step 11 prepares a rolled round metal blank a. The cutting step 12 cuts the blank a into a proper length. The heating step 13 applies a heater 131 providing a fixed and high temperature to heat and soften the blank a. A punch 141 and dies 142 disposed on the punch 141 and provided with a shaping impress are used in the punching step 14. The punching step 14 puts the heated and softened blank a on the dies 142, pressurizes the round blank a to form a flat blank a1 and presses the flat blank a1 to build an impression of a spanner outline R. The cooling step 15 cools the impressed flat blank a1. The removing step 16 prepares a removing machine 161 to remove the residual metal along the peripheral edge of the spanner outline R. Therefore, a finished spanner S1 is completed. However, such heating method requires a high cost for processing with correlated heating machines. Further, the heated blank a1 can only be shaped after the cooling step 15 is done, and this requires more complicated actions and takes much time.

[0003] Referring to Fig. 3 and Fig. 4, a further traditional method 3 of making a spanner S2 is carried out by cold forging. The method 3 comprises a preparing step 31, a head forming step 32, a stamping 33 and a removing step 34. The preparing step 31 prepares a round metal blank b. The head forming step 32 is executed by cold-forging two ends of the round metal blank b to form two round heads h. The stamping 33 uses a stamping press (not shown) to press the round metal blank b with two round heads h whereby the round metal blank b is formed into a flat blank b1 with a spanner outline. The removing step 34 removes the residual metal along the peripheral edge of the spanner outline of the flat blank b1 with another stamping press (not shown). Therefore, a finished spanner S2 is completed. Generally, because the round metal blank b and the round heads h formed at two ends thereof are thick, the metal blank b must be pressed by a particular press. The stamping step 33, however, must prepare a stamping press whose power output and weight is much larger than those of the press used in the head forming step 32 to provide enough driving forces to press the round metal blank b into the flat blank b1 and shape the spanner outline. Therefore, the bulk and the cost of the necessary stamping presses used in the above steps may be much higher than those of the common stamping presses, and this usually increases the processing cost for making the finished spanner S2.

## SUMMARY OF THE INVENTION

[0004] An object of this invention is to provide a method of making a spanner which reduces the waste of the material, shortens the processing time and decreases the manufacturing cost.

[0005] The method of making a spanner of this invention comprises the steps of preparing a flat metal blank (preparing step), forging and pressing a part of the flat metal blank for forming a head and forming a shank which is forged and extended outwards from said head, wherein a width of the shank is smaller than a width of the head (initial forging step), pressing the head to form a first arch-shaped part (first end stamping step), pressing a shank end of the shank far away from the head to expand the shank end and form a second arch-shaped part whose size is smaller than a size of the first arch-shaped part (a second end stamping step), and pressing the head and the shank end again to remove scrap or redundant metal projecting from their arch-shaped parts and punch respective finished holes in the head and the shank end, thereby completing a finished spanner (trimming step). Consequently, the preparation of the flat metal blank for processing facilitates the shortened processing time, the promoted processing efficiency and the reduced amount of scrap and prevents the waste of the material.

[0006] Preferably, a width of the flat metal blank in the preparing step equals a maximum outer diameter of the finished spanner.

[0007] Preferably, when the flat metal blank is prepared as a continuously rolled flat metal blank, a cutting step follows the preparing step. The cutting step cuts the metal blank into sections by using a cutting machine whereby each section of the metal blank is gripped and fed for continuing the initial forging step.

[0008] Preferably, the first end stamping step can not only form the first arch-shaped part by pressing the head but punch a first archetypal hole as an initial form of the finished hole in the first arch-shaped part. Likewise, the second end stamping step can not only form the second arch-shaped part by pressing the shank end but punch a second archetypal hole as an initial form of the finished hole in the second arch-shaped part.

[0009] Preferably, the first end stamping step applies a heading machine to press the head. The heading machine comprises a body, a fixing die and a push unit disposed on the body, a press die disposed opposite the fixing die and a grip unit disposed on the body for gripping and moving the metal blank to where the fixing die is located. The fixing die forms a shaping cavity and a discharging hole communicating with the shaping cavity. The push unit can be inserted into the discharging hole.

[0010] Preferably, the second end stamping step applies a forming machine to press the shank end. The forming machine comprises a pair of lateral dies on which a die cavity is formed and a stamping die disposed in relation to the lateral dies. The shank is gripped by the lateral dies for executing the pressing action.

[0011] Preferably, the heat treatment is further added in this invention. Especially, a heating step is executed before the initial forging step, the first end stamping step or the second end stamping step. Alternatively, the initial forging step, the first end stamping step and the second end stamping step come after a first heating step, a second heating step and a third heating step respectively.

## BRIEF DESCRIPTION OF THE DRAWINGS

### [0012]

Fig. 1 is a block diagram of a first traditional method showing the steps of making a spanner;

Fig. 2 is a perspective representation of making the spanner in accordance with the first traditional method;

Fig. 3 is a block diagram of a second traditional method showing the steps of making a spanner;

Fig. 4 is a perspective representation of making the spanner in accordance with the second traditional method;

Fig. 5 is a block diagram of a first preferred embodiment of this invention showing the steps of making a spanner;

Fig. 6-1 is a perspective representation of making the spanner in accordance with the first preferred embodiment of this invention;

Fig. 6-2 is another perspective representation of making the spanner in accordance with the first preferred embodiment of this invention;

Fig. 7-1 is a block diagram showing the correlated elements of the heading machine of this invention;

Fig. 7-2 is a schematic view showing the heading machine of this invention;

Fig. 8-1 is a block diagram showing the correlated elements of the forming machine of this invention;

Fig. 8-2 is a schematic view showing the forming machine of this invention;

Fig. 9 is a block diagram of a second preferred embodiment of this invention showing the steps of making a spanner;

Fig. 10 is a block diagram of a third preferred embodiment of this invention showing the steps of making a spanner; and

Fig. 11 is a block diagram of a fourth preferred embodiment of this invention showing the steps of making a spanner.

## DETAILED DESCRIPTION OF THE PREFERRED EMBODIMENTS

[0013] Referring to Fig. 5 and Fig. 6-1, a method 4 of a first preferred embodiment of this invention for making a spanner 8 comprises a preparing step 41, an initial forging step 42, a first end stamping step 43, a second end stamping step 44 and a trimming step 45. The preparing step 41 prepares a flat metal blank 5. Herein, the flat metal blank 5 has a shape with four straight sides. It can be especially rectangular in shape as shown. As used herein, a width of the flat metal blank 5 at least equals a maximum outer diameter of the finished spanner 8, and a thickness of the flat metal blank 5 equals a thickness of the finished spanner 8. The initial forging step 42 forges and presses a part of the flat metal blank 5. In this step, the initial forging step 42 subjects a part of the flat metal blank 5 to compressive forces. Therefore, a head 51 and a shank 52 extended outwards from the head 51 are formed into a T-shaped contour. Specifically, the head 51 is formed at one end of the flat metal blank 5, and the compressed shank 52 connected to the head 51 provides a reduced width  $w_2$  smaller than a width  $w_1$  of the head 51. By this step, it is possible that the width  $w_1$  of the head 51 equals the original width of the flat metal blank 5.

[0014] Furthermore, the first end stamping step 43 presses the head 51 to form a first arch-shaped part d1 which is a part with a curved or arched peripheral wall as the archetype of the spanner end. More specifically, the first end stamping step 43 in this preferred embodiment applies a heading machine 6 to press the head 51. Referring to Fig. 7-1 and Fig. 7-2, the heading machine 6 comprises a body 61, a fixing die 62 and a push unit 63 disposed on the body 61, a press die 64 disposed opposite the fixing die 62 and a grip unit 65 disposed on the body 61 for gripping and moving the metal blank 5 to where the fixing die 62 is located. The fixing die 62 has a shaping cavity 621 formed thereon and a discharging hole 622 communicating with the shaping cavity 621. The push unit 63 can be inserted into the discharging hole 622. When the metal blank 5 with the head 51 is placed onto the fixing die 62 by using the grip unit 62, the head 51 is accommodated in the shaping cavity 621 and pressed by the press die 64 to form the first arch-shaped part d1 as shown in Fig. 6-1. Further, the time of punching a hole in the head 51 is decided by the structure of the dies. For example, the head 51, as shown in Fig. 6-1, may not be punched or perforated in this step, or a first archetypal hole h1 may be punched in the first arch-shaped part d1 at the time of pressing as shown in Fig. 6-2 so that it is set as an initial form of a first finished hole 81 of the finished spanner 8. The push unit 63 then goes into the discharging hole 622 to push the metal blank 5. Thus, the metal blank 5 is removed from the fixing die 62 to continue the step 44.

[0015] The second end stamping step 44 presses a shank end 521 of the shank 52 in an opposite direction to or far away from the head 51 to form a second arch-shaped part d2 which is a part with a curved or arched peripheral wall as the archetype of the spanner end. More specifically, the second end stamping step 44 in this preferred embodiment applies a forming machine 7 to press the shank end 521 of the shank 52. Referring to Fig. 8-1 and Fig. 8-2, the forming machine 7 comprises a pair of lateral dies 71 between which the metal blank 5 is placed and gripped and a stamping die 72 disposed in relation to the pair of lateral dies 71. The pair of lateral dies 71 forms a die cavity 711 thereon. When the shank 52 of the metal blank 5 is firmly gripped by the lateral dies 71, the stamping die 72 presses the shank end 521 so that the shank end 521 becomes deformed and expanded by the pressing force. The deformed and expanded shank end 521 then fills the die cavity 711 to form the second arch-shaped part d2 whose size may be smaller than the size of the first arch-shaped part d1. Further, the time of punching a hole in the shank end 521 is also decided by the structure of the dies. For example, the shank end 521, as shown in Fig. 6-1, may not be punched or perforated in this step, or a second archetypal hole h2 may be punched in the second arch-shaped part d2 at the time of pressing as shown in Fig. 6-2 so that it is set as an initial form of a second finished hole 82 of the finished spanner 8. Thereafter, the metal blank 5 is removed from the lateral dies 71 to attain a half-finished spanner ready for the next step 45.

[0016] The trimming step 45 removes scrap or redundant metal projecting from the first arch-shaped part d1 of the head 51 and the second arch-shaped part d2 of the shank 52 by pressing two ends of the half-finished spanner again, namely, the head 51 and the shank end 521 as discussed. Because the amount of the scrap is not much, this step 45, different from the prior technique, attains the removal of the scrap without using the stamping press with large metric tons. This reduces the cost and makes the pressed portions neat. Concurrently, respective finished holes 81, 82 with the desired dimensions and shapes are also formed on the head 51 and the shank end 521, thereby completing a finished spanner 8. It is also noted that these finished holes 81, 82 can be more easily and quickly punched if the first archetypal hole h1 and the second archetypal hole h2, as previously described, are made before the trimming step 45.

[0017] The shape of the finished spanner 8 can be classified into three common types. For example, as shown in Fig. 6-2, the A type comprises two ring-shaped heads at two ends of the spanner 8, each of which forms a central hole 81(82). The B type comprises a ring-shaped head with a central hole 81 and jaws with an arch-shaped contour and an open hole 82. The C type two sets of jaws, each of which provides an open hole 81 (82). The shape of the spanner 8 can be changed according to the structure of manufacturing dies.

[0018] Referring to Fig. 9, a second preferred embodiment of this invention for making a spanner 8 still comprises a preparing step 41, an initial forging step 42, a first end stamping step 43, a second end stamping step 44 and a trimming step 45. This embodiment is characterized in that the flat metal blank 5 of the preparing step 41 is continuously rolled, and the preparing step

**41** is followed by a cutting step **46**. The cutting step **46** cuts the rolled metal blank **5** into sections by using a cutting machine **9** at the time of feeding the metal blank **5**. After the metal blank **5** is cut into sections, these sections can be directly and sequentially gripped and fed for continuing the steps **42**, **43**, **44**, **45**. The actions of the steps **42**, **43**, **44**, **45** are the same as those of the first preferred embodiment and herein are omitted.

[0019] Referring to Fig. **10** and Fig. **11**, a third preferred embodiment and a fourth preferred embodiment of this invention still comprise a preparing step **41**, an initial forging step **42**, a first end stamping step **43**, a second end stamping step **44** and a trimming step **45**. The fourth preferred embodiment differs from the third preferred embodiment in having the rolled metal blank **5** and the cutting step **46** as previously described. Particularly, these two preferred embodiments include a heating step **47** to heat the metal blank **5** by the high-frequency induction or other heating means. Specifically, the heating step **47** can be executed before the initial forging step **42**, the first end stamping step **43** or the second end stamping step **44**. Alternatively, the heating step **47** can be executed before all the steps **42**, **43**, **44**. As used herein, the initial forging step **42** follows a first heating step **47a**, the first end stamping step **43** follows a second heating step **47b**, and the second end stamping step **44** follows a third heating step **47c**. By using the heating means, the metal blank **5** forms the head **51** and the shank **52** quickly and easily in the initial forging step **42**, shapes the first arch-shaped part **d1** quickly and easily in the first end stamping step **43** and/or shapes the second arch-shaped part **d2** quickly and easily in the second end stamping step **44**. This also effects the small amount of the scrap, decreases the waste of the material, shortens the working time and increasing the processing efficiency.

[0020] Therefore, this invention attains the effects:

1. When the preparing step **41** prepares the flat metal blank **5**, the following stamping steps **43**, **44** can use the simple heading machine and the forming machine capable of arranging a mass production to replace traditional stamping presses with the large bulk and metric tons. Therefore, the processing and manufacturing efficiency can be increased.
2. The stamping steps **43**, **44** subject the head **51** and the shank end **521** of the shank **52** to respective pressing works, so the appearance of the spanner **8** can be quickly and easily shaped with less scrap, and the unnecessary loss and waste of the material is decreased.

[0021] The trimming step **45** only needs to remove very little scrap, thereby completing the finished spanner **8** quickly and easily.

[0022] To sum up, this invention takes advantage of the flat metal blank to form the head and the shank directly. Therefore, two ends of the metal blank in the two stamping steps can be directly formed into the arch-shaped parts prepared for the archetype of the spanner to attain a half-finished spanner. The trimming step is mainly to remove the scrap or redundant metal left on the two ends of the half-finished spanner and make sure that the finished hole are well punched, thereby completing a finished spanner. Therefore, the preparation of the flat metal blank allow the arch-shaped parts to be directly and quickly formed, thereby shortening the processing time, increasing the processing and forming efficiency and decreasing the cost.

[0023] While the embodiments of this invention are shown and described, it is understood that further variations and modifications may be made without departing from the scope of this invention.

**Patentkrav**

**1.** Fremgangsmåde (4) til fremstilling af en skruenøgle (8), **kendetegnet ved at** fremgangsmåden (4) omfatter:

- 5 et forberedelsestrin (41) til at forberede et fladt metalemne (5);
- et indledende smedningstrin (42) til at smede og trykke en del af det flade metalemne (5), hvorved et hoved (51) dannes ved en ende af det flade metalemne (5), og et skaft (52) smedes og strækkes udad fra hovedet (51), hvilket skaft (52) har en reduceret bredde ( $w_2$ ) mindre end en
- 10 bredde ( $w_1$ ) af hovedet (51);
- et første endepresningstrin (43) til at trykke hovedet (51), hvorved hovedet (51) danner en første bueformet del ( $d_1$ );
- et andet endepresningstrin (44) til at trykke en skaftende (521) af skaftet (52) langt væk fra hovedet (51), hvorved skaftenden (521) bliver udvidet
- 15 af trykkraften for at danne en anden bueformet del ( $d_2$ ), hvor en størrelse af den anden bueformede del ( $d_2$ ) er mindre end en størrelse af den første bueformede del ( $d_1$ ) af hovedet (51); og
- et trimningstrin (45) til at trykke hovedet (51) og skaftenden (521) igen for at fjerne affald fremspringende fra den første bueformede del ( $d_1$ ) og den
- 20 anden bueformede del ( $d_2$ ) og at stanse et første færdigt hul (81) og et andet færdigt hul (82) i henholdsvis hovedet (51) og skaftenden (521) for derved at færdiggøre en færdig skruenøgle (8).

**2.** Fremgangsmåden (4) til fremstilling af en skruenøgle (8) ifølge krav 1, hvor en

25 bredde af det flade metalemne (5) i forberedelsestrinnet (41) er lig med en maksimum ydre diameter af den færdige skruenøgle (8).

**3.** Fremgangsmåden (4) til fremstilling af en skruenøgle (8) ifølge krav 1, hvor det flade metalemne (5) i forberedelsestrinnet (41) kontinuerligt vales, hvor

forberedelsestrinnet (41) efterfølges af et skæringstrin, hvilket skæringstrin skærer metalemnet (5) i afsnit med en skæremaskine (9), hvorved hvert afsnit af det skårne metalemne (5) gribes og fødes til fortsættelse af det indledende smedningstrin (42).

5

**4.** Fremgangsmåden (4) til fremstilling af en skruenøgle (8) ifølge krav 1, hvor det første endepresningstrin (43) danner den første bueformede del (d1) ved at trykke hovedet (51) og også stanser et første arketypehul (h1) som en indledende form af det første færdige hul (81) i den første bueformede del (d1).

10

**5.** Fremgangsmåden (4) til fremstilling af en skruenøgle (8) ifølge krav 1 eller 4, hvor det første endepresningstrin (43) trykker hovedet (51) med en hovedmaskine (6), hvilken hovedmaskine (6) omfatter et legeme (61), en fastgørelsesmatrice (62) og en skubbeenhed (63) anbragt på legemet (61), en trykmatrice (64) anbragt modstående fastgørelsesmatricen (62) og en gribeenhed (65) anbragt på legemet (61) til at gribe og bevæge metalemnet (5) til hvor fastgørelsesmatricen (62) er lokaliseret, hvor fastgørelsesmatricen (62) har et formningshulrum (621) dannet derpå og et udledningshul (622) i forbindelse med formningshulrummet (621) og der tillader en indsættelse af skubbeenheden (63).

20

**6.** Fremgangsmåden (4) til fremstilling af en skruenøgle (8) ifølge krav 1, hvor det andet endepresningstrin (44) danner den anden bueformede del (d2) ved at trykke skaftenden (521) og også stanser et andet arketypehul (h2) som en indledende form af det andet færdige hul (82) i den anden bueformede del (d2).

25

**7.** Fremgangsmåden (4) til fremstilling af en skruenøgle (8) ifølge krav 1 eller 6, hvor det andet endepresningstrin (44) trykker skaftenden (521) af skaftet (52) med en formmaskine (7), hvilken formmaskine (7) omfatter et par laterale matricer (71) mellem hvilke skaftet (52) placeres og gribes og en presningsmatrice (72) anbragt i forhold til parret af laterale matricer (71), hvilket par af laterale matricer (71) danner et matricehulrum (711) derpå.

30

**8.** Fremgangsmåden (4) til fremstilling af en skruenøgle (8) ifølge krav 1, hvor det indledende smedningstrin (42) følger et første opvarmningstrin (47a), det første endepresningstrin (43) følger et andet opvarmningstrin (47b), og det andet endepresningstrin (44) følger et tredje opvarmningstrin (47c).

5

**9.** Fremgangsmåden (4) til fremstilling af en skruenøgle (8) ifølge krav 1, hvor et opvarmningstrin (47) tilføjes før et hvilket som helst af det indledende smedningstrin (42), det første endepresningstrin (43) eller det andet endepresningstrin (44).

**DRAWINGS**

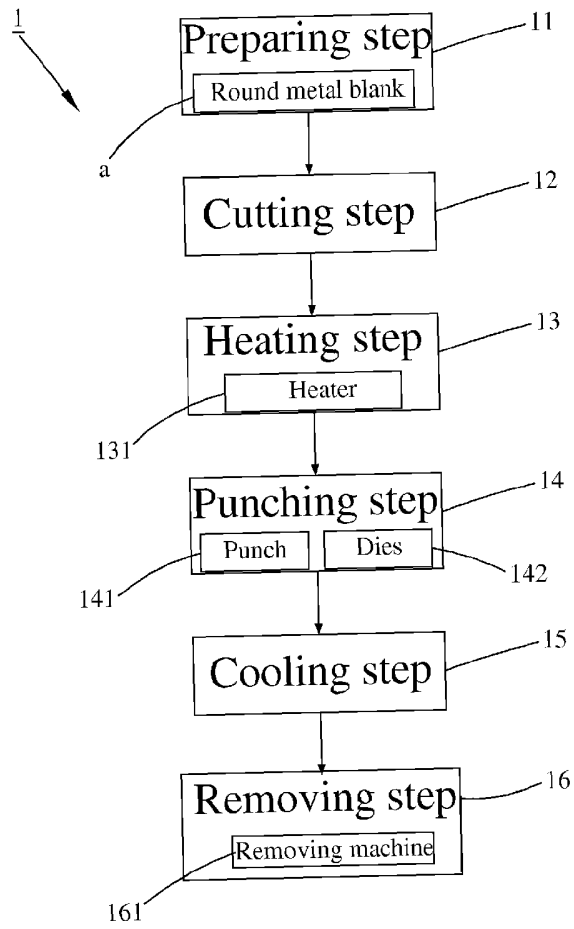

**FIG. 1**  
**(PRIOR ART)**

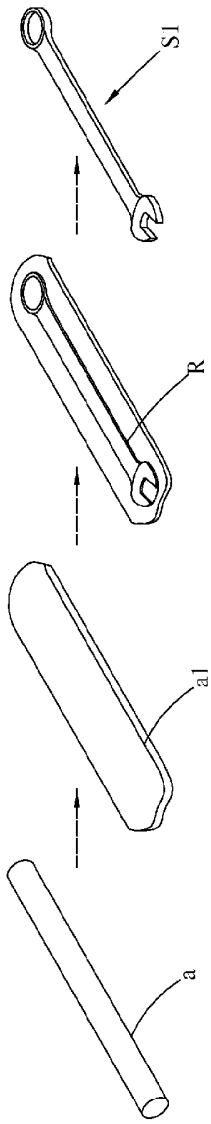

FIG. 2  
(PRIOR ART)

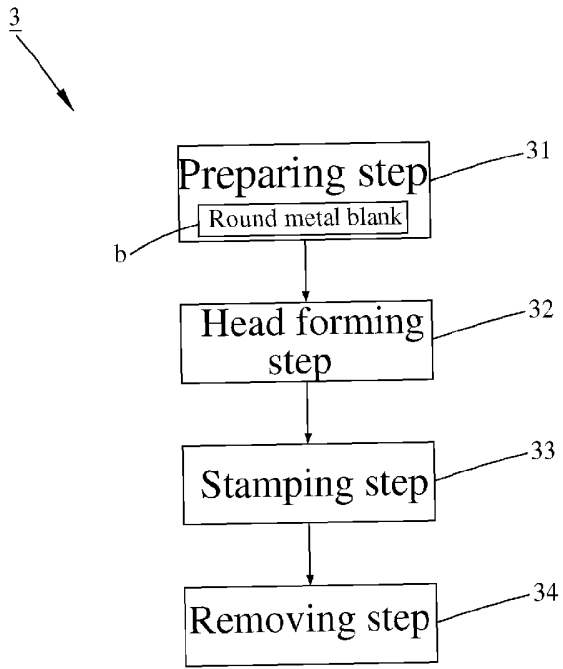

FIG. 3  
(PRIOR ART)

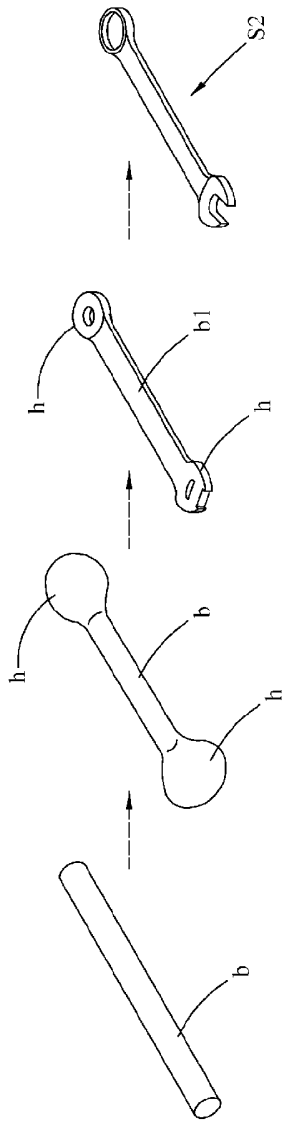

FIG. 4  
(PRIOR ART)

4  
↙

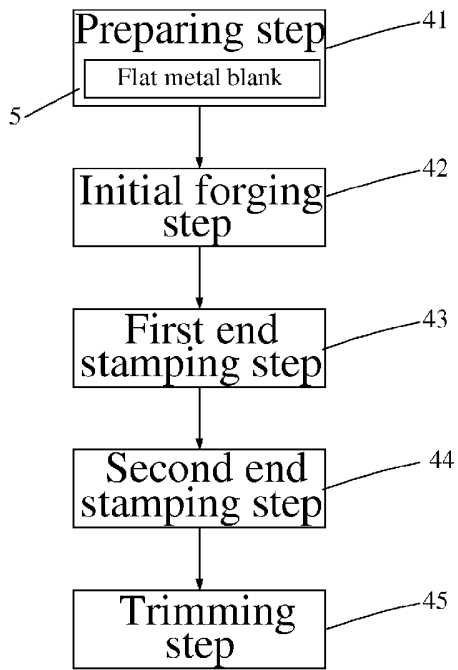

FIG. 5

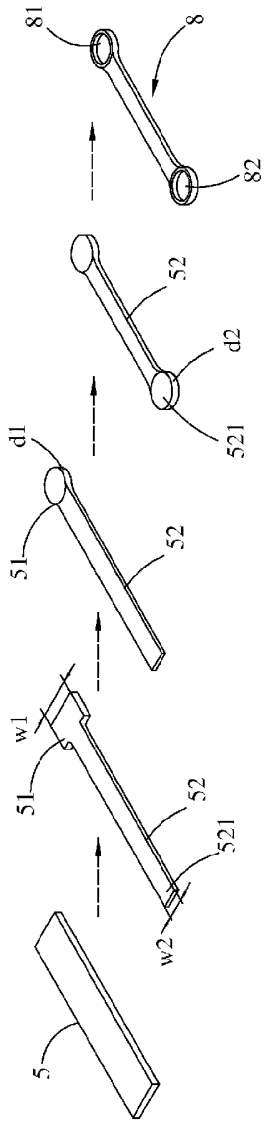

FIG. 6-1

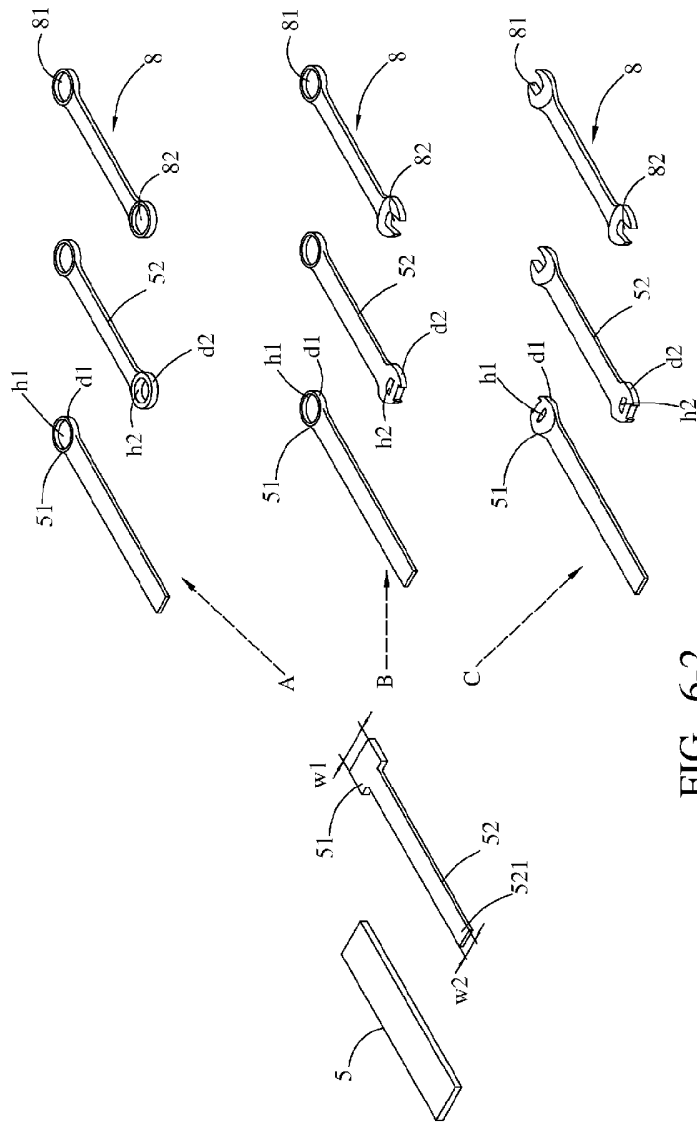

FIG. 6-2

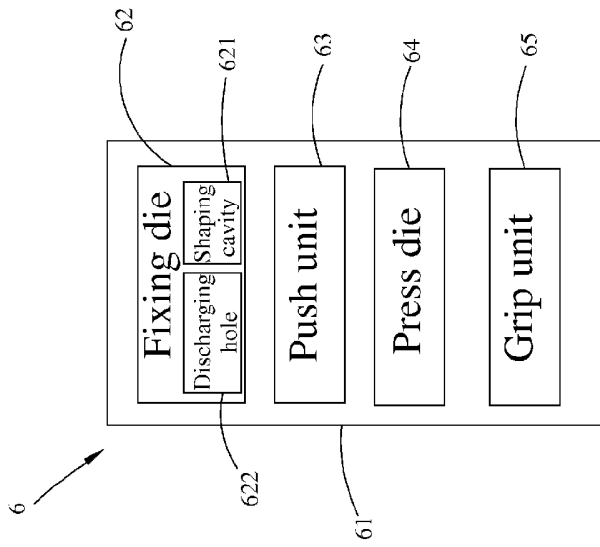

FIG. 7-1

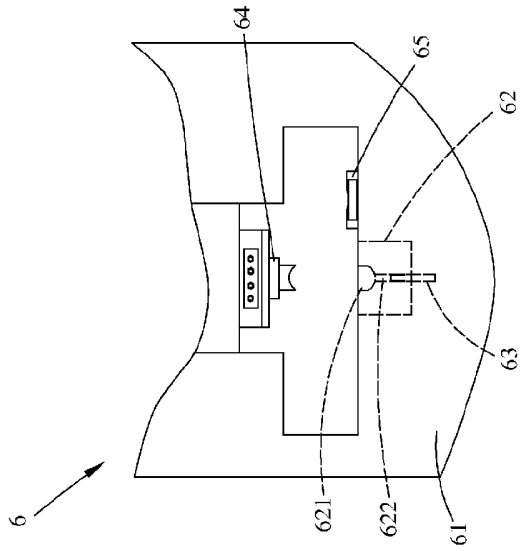

FIG. 7-2

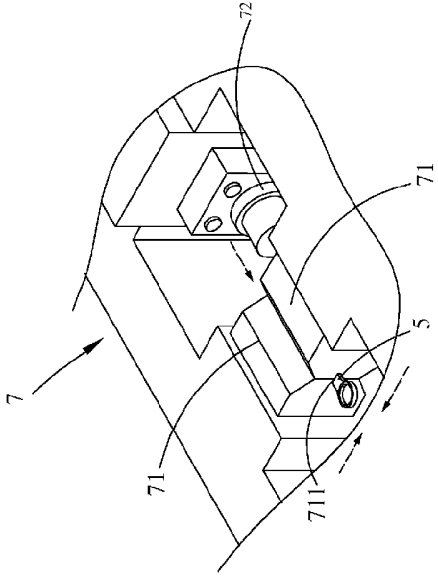

FIG. 8-2

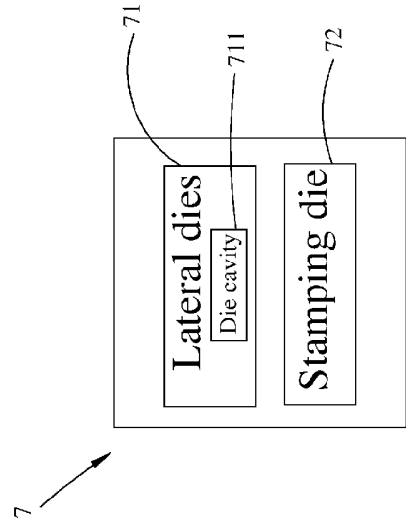

FIG. 8-1

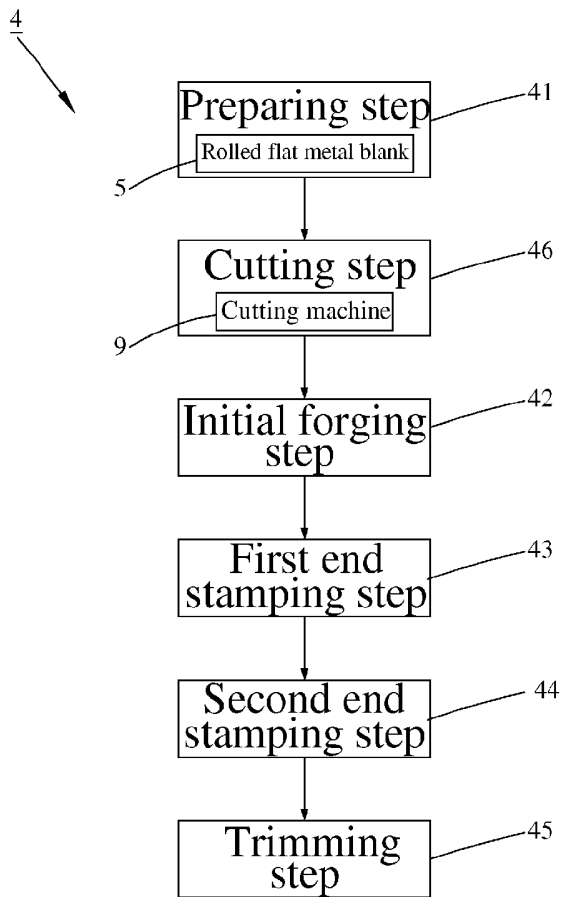

FIG. 9

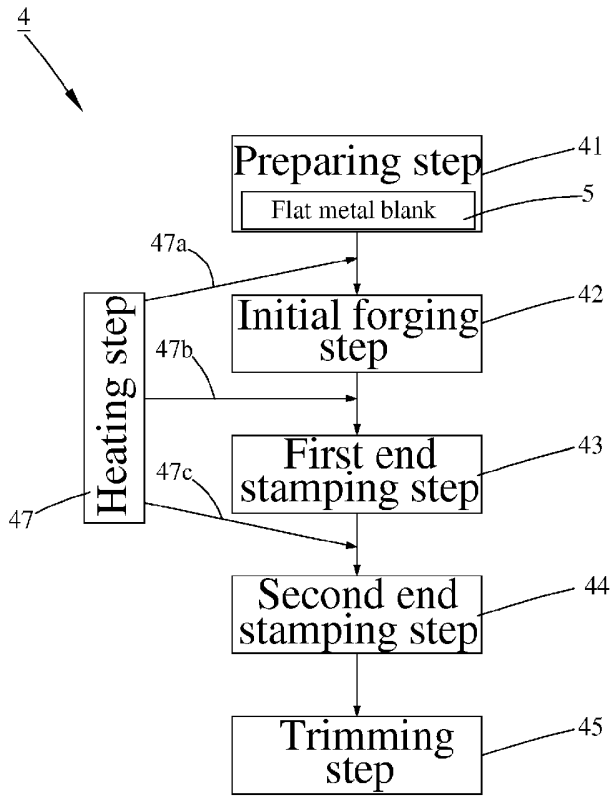

FIG. 10

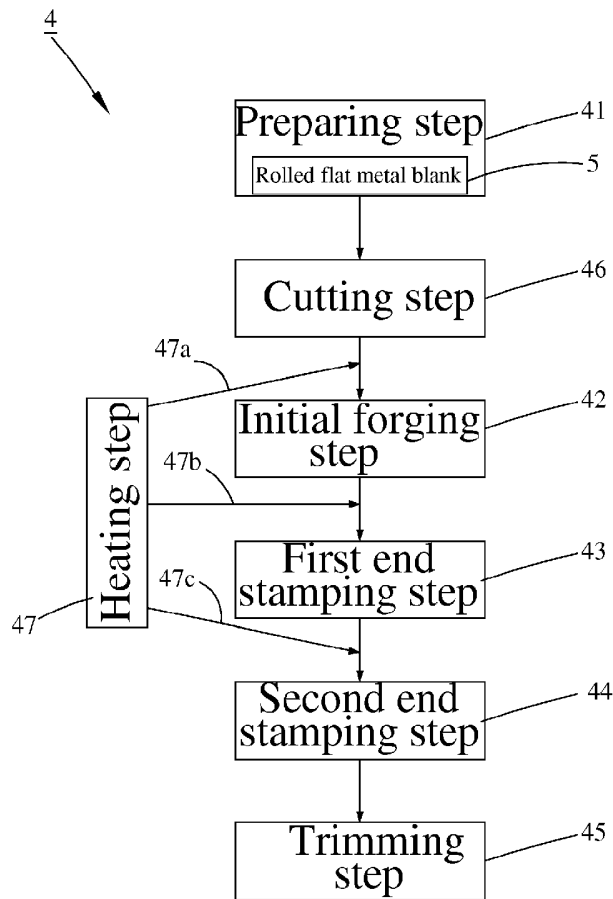

FIG. 11