

(No Model.)

F. G. KOEHLER & H. G. HARTMANN.
COMBINED INVALID'S TABLE AND DESK.

No. 525,554.

Patented Sept. 4, 1894.

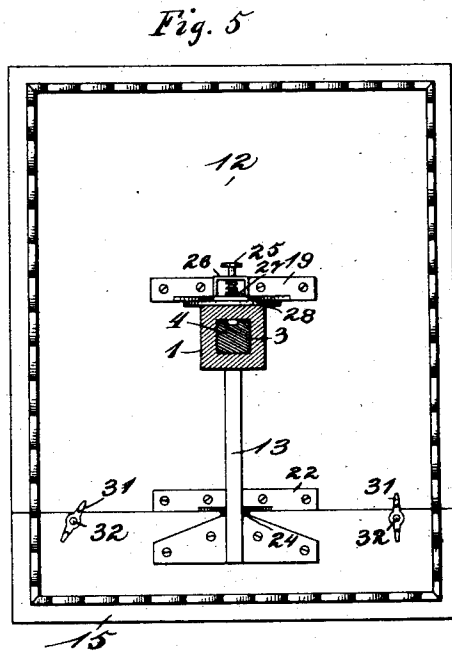
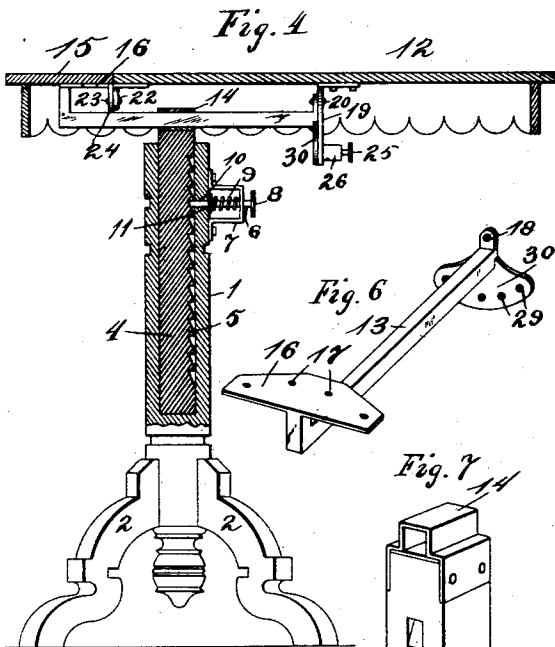
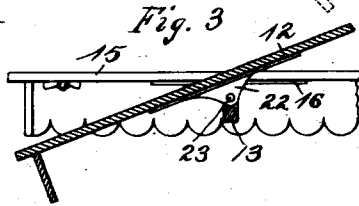
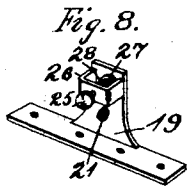
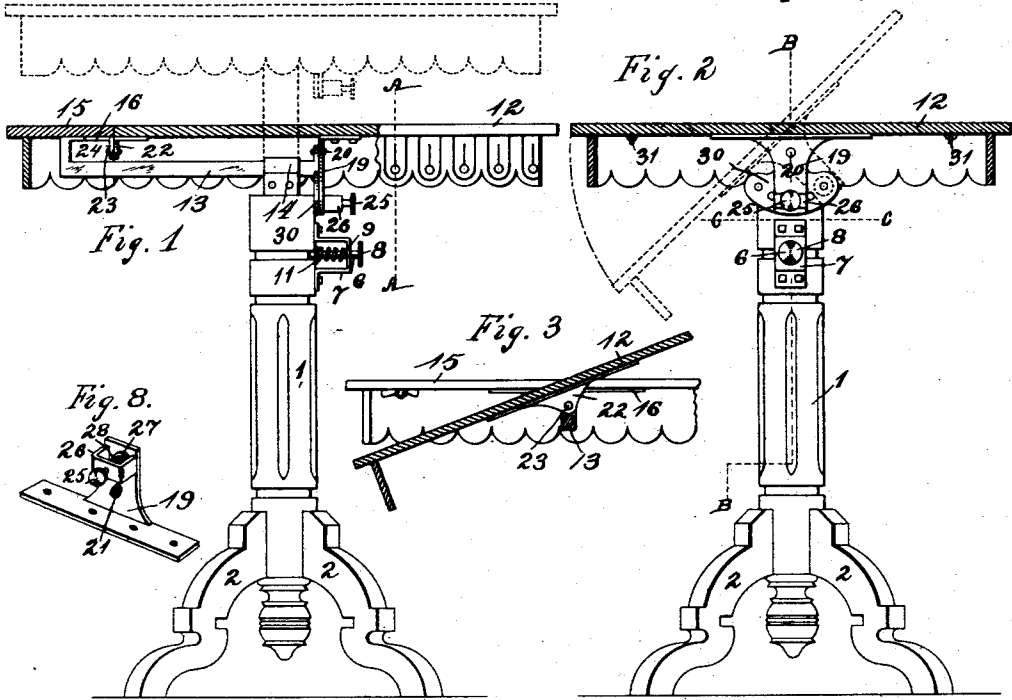

Witnesses
 W. J. Sankey,
 J. C. H. Longan

Inventors,
 Frank S. Koehler & Henry S. Hartmann
 By Higdon & Higdon & Longan Attys.

UNITED STATES PATENT OFFICE.

FRANK G. KOEHLER AND HENRY G. HARTMANN, OF ST. LOUIS, MISSOURI.

COMBINED INVALID'S TABLE AND DESK.

SPECIFICATION forming part of Letters Patent No. 525,554, dated September 4, 1894.

Application filed May 29, 1893. Serial No. 475,835. (No model.)

To all whom it may concern:

Be it known that we, FRANK G. KOEHLER and HENRY G. HARTMANN, of the city of St. Louis and State of Missouri, have invented certain new and useful Improvements in a Combined Invalid's Table and Desk, of which the following is a full, clear, and exact description, reference being had to the accompanying drawings, forming a part hereof.

Our invention relates to tables of that class which have a tilting top adjustably mounted upon a stand, and consists in the novel construction, combination and arrangement of parts hereinafter specified and designated in the claims.

The object of our invention is to provide a cheap, simple and convenient table especially adapted for the use of invalids who are bed-ridden, draftsmen who desire a portable and adjustable drawing-table, and others who desire a portable and adjustable writing-table or desk.

In the drawings: Figure 1 is a rear elevation with parts in section, of a table embodying our invention. Fig. 2 is a sectional end elevation of same, the section being taken on the line A—A of Fig. 1. Fig. 3 is a detail view of a portion of the table-top, with parts broken away, and with the top tilted and shown in transverse section. Fig. 4 is a sectional elevation on the line B—B of Fig. 2. Fig. 5 is an inverted sectional plan view, the section being taken on the line C—C of Fig. 2. Fig. 6 is a detail view in perspective of a horizontal slide-rod, made use of in carrying out the invention. Fig. 7 is a detail view in perspective of the upper end of the standard. Fig. 8 is a detail view in perspective of a locking bracket made use of in the invention.

1 indicates the standard which is provided with the usual supporting legs 2. This standard preferably has a rectangular bore, or a bore 3 that is angular in cross-section. The lower end of this bore is closed and its upper end is open.

Located within the bore 3 and adjustable longitudinally therein is a shank 4 which is angular in cross-section so as to correspond in shape to the shape of the bore in the standard. Formed upon one of the vertical sides of the shank 4 is a series of teeth or depressions 5, which are engaged by a suitable lock-

ing device, to hold said shank in proper adjustment with relation to the said standard. This locking device consists of a bolt 6 mounted in a suitable bracket 7 upon the exterior of the standard adjacent the upper end thereof. The bolt 6 is provided with a head 8 at its outer end and the inner end projects inward and is normally held in engagement with the teeth or depressions 5 of the shank by means of a suitable coil spring 9. The bolt 6 operates in a horizontal opening or passage 10 formed in the side of the standard between the legs of the bracket 7. A shoulder or projection 11 is formed upon the said bolt at a point adjacent its inner end, and the inner end of the spring 9 rests in contact with this shoulder or projection while the outer end of said spring rests in contact with the bracket 7. 12 indicates the table-top, which is connected to the upper end of the shank 4 to slide and tilt thereon, in the manner herein-after described.

13 indicates a slide-rod which is preferably rectangular or angular in cross-section and located in a horizontal position upon the upper end of the shank 4 with its body loosely engaging a horizontal bearing 14 which is also angular in cross-section and secured upon the upper end of said shank in any desired manner.

The purpose in constructing the bore of the standard the shank 4, the slide-rod 13 and the horizontal bearing 14 angular in cross-section is to prevent rotation or revolublemovement of said shank in said bore and slide rod in said bearings.

The table-top is constructed in two sections, a tilting-section, which is the main section, which is mounted upon the slide-rod 13, to tilt, and a smaller horizontal section 15, which is fixed upon said slide-rod to always retain a horizontal position, no matter at what angle the main section may be adjusted. The horizontal section 15 is preferably located at one end of the main-section, and is preferably of the same width as the main-section, but having a length a number of times less than its width, as its purpose is to simply support ink-bottles, and writing-materials, drawing instruments, &c., while the main-section is tilted.

The ends of the slide-rod 13 are preferably

turned upward at an angle to the body of the rod, and one of the turned up portions is provided with a fixed flange 16 having a series of holes or perforations 17, while the other
 5 turned up portion is provided with a horizontal perforation 18. The horizontal section 15 is mounted upon the flange 16 of the slide-rod with its under surface in contact with the upper surface of said flange, and it is secured
 10 in position by means of suitable screws or fastenings passed through the apertures in said flange and engaging said section.

Secured to the under side of the main section 12 about midway of the length thereof is
 15 a depending locking-bracket 19 to which the upturned inner end of the slide rod is connected by means of a bolt or rivet 20 passing through an aperture 21 in said bracket and engaging the horizontal perforation 18 in said
 20 upturned end. This forms a support for one end of the main section of the top. The opposite end of said main section is pivotally connected to the contiguous end or edge of the horizontal section 15 by means of a depending hinge-ear 22 having its upper end
 25 secured to the under surface of said main section and its body provided with a horizontal perforation which is engaged by a bolt or rivet 23 also engaging a depending hinge-ear
 30 24 formed upon the inner edge of the flange 16. The main section 12 is thus pivotally mounted upon the slide-rod 13 so that it may be tilted with relation to the horizontal section 15 and the standard 1. The tilting section 12 is locked in the desired adjustment
 35 by means of a bolt 25 mounted in a bracket 26 carried by the locked-bracket 19 at a point below the plane of the bolt or rivet 20.

A shoulder or projection 27 is formed upon
 40 the bolt 25 adjacent its inner end, and a spring 28 is located upon said bolt with one of its ends in contact with said shoulder or projection and its opposite end in contact with the bracket 26 so as to normally hold said bolt
 45 with its inner end in engagement with one of a series of apertures or depressions 29 formed in a depending flange 30 carried by the slide-rod 13 at a point adjacent the lock-bracket 19. The series of apertures or depressions 29
 50 in the depending flange 30 is arranged radially with the center of the bolt or rivet 20 as the center of a circle conceived to pass through the center of each aperture or depression of the series.

The operation is as follows: When it is desired to adjust the height of the table with relation to the standard, the shank 4 is slid longitudinally in the bore 3 of said standard until the desired height of the table is secured
 60 when said table or top will be retained in such position by means of the bolt 6 engaging the teeth or depressions 5 of said shank. The teeth 5 are commonly known as ratchet-teeth, so that the end of the bolt 6 projects
 65 beneath said teeth to support the table-top at whatever point it is adjusted to, and said

teeth slide upward in contact with the adjacent end of the bolt without direct obstruction when said shank is pulled upward or is to be removed from the standard. When it
 70 is desired to lower the shank and table-top all that is necessary is to withdraw the bolt 6 by means of its knob or handle 8 until its inner end is detached from the teeth or depressions 5 in the shank, when said shank will
 75 gravitate downward or may be adjusted downward or upward by hand. When it is desired that the table be used for reading or writing by a bed-ridden invalid, the standard and feet of the table are placed closely adjacent
 80 the side of the bed, and the entire table-top is then slid longitudinally upon the standard (the slide-rod 13 sliding in the bearing 14) until the table-top projects for the greater portion of its length upon one side of the
 85 standard, and such length overhangs the bed, and then the table will be in such a position that the invalid may conveniently reach articles placed upon it, and do writing, reading, &c., while the table-top supports the writing
 90 or reading-materials directly above the bed. The slide-rod 13 may be adjusted until any portion of its length interior of the upturned ends, engages the bearing 14 carried by the shank 4, thereby permitting a prepon-
 95 derance of the length of the top to project at one side of the standard or permitting an equal length of same to project on either side of said standard. We have found these to be important functions, adding greatly to the
 100 convenience of the uses of tables and desks of the class having a single vertical standard.

When it is desired to tilt the main-section 12, all that is necessary is to withdraw the inner end of the bolt 25 from engagement with
 105 the central aperture 29 of the flange 30 carried by the slide-rod, when said section may be readily tilted to any appropriate angle, as indicated by dotted lines in Fig. 2 and as shown in Fig. 3, while the horizontal section
 110 15 remains stationary in a horizontal position, and immediately upon releasing the bolt 25 its spring 28 causes it to return to normal position with its inner end in engagement with one of the apertures 29 in said flange 30, and
 115 the section 12 will thus be held in a desired tilted position.

Although the bolt 25 and the apertured flange 30 usually act to hold the two sections 12 and 15 in proper relative positions with
 120 sufficient rigidity, yet we have found that in other cases it is desirable to lock the two sections still more rigidly together when they are adjusted to form a horizontal top, and therefore we have provided suitable fasten-
 125 ings for this purpose.

We prefer simple turn-buttons 31 pivotally attached by means of screws or other common fastenings 32 to the under side of the horizontal section 15 adjacent the inner
 130 end thereof, so as to be turned and overlap the adjacent end of the tilting section and

thereby hold the two sections with their meeting edges parallel. (See Figs. 2, 3, and 5.)

What we claim is—

1. The improved table or desk having a
5 standard and vertically moving bearing within said standard, said bearing having a horizontally sliding rectangular bar mounted in its upper portion, said rectangular slide-
bar having a table section rigidly secured to
10 one end thereof, the other end of said slide-bar being hinged to a casting secured to and depending from the bottom of the mating
table section, substantially as specified.

2. In a combined table and desk, the com-
15 bination of two top sections a rectangular bar horizontally sliding and mounted in a bearing on the table standard, one end of

said bar formed into an upwardly extending portion and plate to be rigidly secured to the non-tilting table section, the other end of the
20 bar provided with an upwardly extending lug and a downwardly extending plate provided with a series of apertures, thus forming a hinge connection and latching device for a depending casting secured to the tilting table
25 top section, substantially as specified.

In testimony whereof we affix our signatures in presence of two witnesses.

FRANK G. KOEHLER.
HENRY G. HARTMANN.

Witnesses:

EDWARD E. LONGAN,
JNO. C. HIGDON.