



US00RE38465E

(19) **United States**  
(12) **Reissued Patent**  
**Matsuzawa et al.**

(10) **Patent Number: US RE38,465 E**  
(45) **Date of Reissued Patent: Mar. 16, 2004**

(54) **EXPOSURE APPARATUS**

**FOREIGN PATENT DOCUMENTS**

(75) Inventors: **Hitoshi Matsuzawa**, Tokyo (JP);  
**Mikihiko Ishii**, Saitama-ken (JP); **Issey Tanaka**,  
Yokohama (JP)

DE	34 43 856 A1	6/1985
JP	47-35017	9/1972
JP	55-12902	1/1980
JP	58-4112	1/1983

(73) Assignee: **Nikon Corporation**, Tokyo (JP)

(List continued on next page.)

(21) Appl. No.: **09/772,848**

**OTHER PUBLICATIONS**

(22) Filed: **Jan. 31, 2001**

SPIE, vol. 811 Optical Microlithographic Technology for Integrated Circuit Fabrication and Inspection (1987), "Quality of Microlithographic Projection Lenses", Joseph Braat, pp. 22-30.

**Related U.S. Patent Documents**

Reissue of:

(64) Patent No.: **6,104,544**  
Issued: **Aug. 15, 2000**  
Appl. No.: **08/885,694**  
Filed: **Jun. 30, 1997**

U.S. patent application Ser. No. 08/152,490, refiled as U.S. patent application Ser. No. 08/727,206, which was refiled as U.S. patent application Ser. No. 08/929,155; Apr. 23, 1999 which was allowed, but no issue date or patent number.\*

U.S. patent application Ser. No. 08/255,927, filed Jun. 7, 1994, Nakashima et al. U.S. Pat. No. 5,534,970, issue date Jul. 9, 1996.\*

U.S. Applications:

(63) Continuation of application No. 08/706,761, filed on Sep. 3, 1996, now abandoned, which is a continuation of application No. 08/384,081, filed on Feb. 6, 1995, now abandoned.

(List continued on next page.)

(30) **Foreign Application Priority Data**

Dec. 14, 1994 (JP) ..... 6-311050

(51) **Int. Cl.**<sup>7</sup> ..... **G02B 3/00**; G02B 21/02;  
G02B 15/14; G02B 9/62

(52) **U.S. Cl.** ..... **359/649**; 359/656; 359/658;  
359/679; 359/757; 359/773

(58) **Field of Search** ..... 359/649, 656-658,  
359/679, 754-757, 766, 369, 385, 391,  
428, 773; 355/67, 53

*Primary Examiner*—Evelyn Lester

(74) *Attorney, Agent, or Firm*—Oliff & Berridge PLC

(57)

**ABSTRACT**

A projection optical system of the present invention has a first lens group  $G_1$  being positive, a second lens group  $G_2$  being negative, a third lens group  $G_3$  being positive, a fourth lens group  $G_4$  being negative, a fifth lens group  $G_5$  being positive, and a sixth lens group  $G_6$  being positive in the named order from the first object toward the second object, in which the second lens group  $G_2$  comprises an intermediate lens group  $G_{2M}$  between a negative front lens  $L_{2F}$  and a negative rear lens  $L_{2R}$  and in which the intermediate lens group  $G_{2M}$  is arranged to comprise at least a first positive lens being positive, a second lens being negative, a third lens being negative, and a fourth lens being negative in the named order from the first object toward the second object. The present invention involves findings of suitable focal length ranges for the first to the sixth lens groups  $G_1$  to  $G_6$  and an optimum range of an overall focal length of from the second negative lens to the fourth lens with respect to a focal length of the second lens group  $G_2$ .

(56) **References Cited**

**U.S. PATENT DOCUMENTS**

3,737,215 A	6/1973	De Jager	359/760
3,909,115 A	9/1975	Kano	359/754
3,955,883 A	5/1976	Sugiyama	359/752
4,080,048 A	3/1978	Kimura	359/750
4,666,273 A	5/1987	Shimizu et al.	353/101
4,770,477 A	9/1988	Shafer	359/355

(List continued on next page.)

**190 Claims, 14 Drawing Sheets**

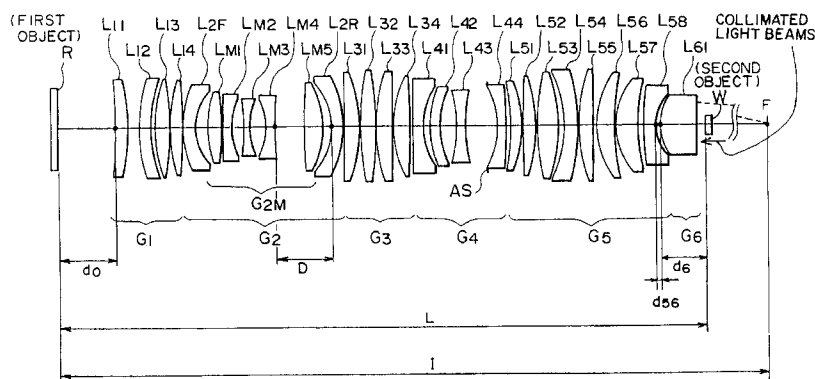

U.S. PATENT DOCUMENTS

4,772,107	A	9/1988	Friedman .....	359/754
4,811,055	A	3/1989	Hirose .....	355/53
4,891,663	A	1/1990	Hirose .....	343/786
4,977,426	A	12/1990	Hirose .....	355/53
5,097,291	A	3/1992	Suzuki .....	355/69
5,105,075	A	4/1992	Ohta et al. ....	250/201.2
5,159,496	A	10/1992	Kataoka .....	359/754
5,170,207	A	12/1992	Tezuka et al. ....	355/53
5,194,893	A	3/1993	Nishi .....	355/53
5,235,465	A	8/1993	Hayashi .....	359/656
5,245,384	A	9/1993	Mori .....	355/67
5,247,324	A	9/1993	Estelle .....	359/679
5,260,832	A	11/1993	Togino et al. ....	359/679
5,493,402	A	2/1996	Hirukawa .....	356/400
5,506,684	A	4/1996	Ota et al. ....	356/401
5,534,970	A	7/1996	Nakashima et al. ....	355/53
5,636,000	A	6/1997	Ushida et al. ....	355/30
5,781,278	A	7/1998	Matsuzawa et al. ....	359/757
5,805,344	A	9/1998	Sasaya et al. ....	359/649
5,831,770	A	11/1998	Matsuzawa et al. ....	359/649
5,835,285	A	11/1998	Matsuzawa et al. ....	359/649
5,856,884	A	1/1999	Mercado .....	359/649
5,943,172	A	8/1999	Sasaya et al. ....	359/754
RE37,846	E	* 9/2002	Matsuzawa et al. ....	359/649

FOREIGN PATENT DOCUMENTS

JP	63-118115	5/1988
JP	4-157412	3/1992
JP	5-107469	4/1993
JP	5-164962	6/1993
JP	5-173065	7/1993
JP	6-313845	11/1994
JP	6-331941	12/1994
JP	6-349701	12/1994
JP	7-140385	6/1995
JP	179204	7/1996
SU	1659951 A1	6/1991
WO	WO 93/04391	3/1993

OTHER PUBLICATIONS

Naumann, Schroder, "Bauelemente der Optik", 6<sup>th</sup> Ed. 1992  
 Munich, Vienna, pp. 379, 393.  
 Erhard Glatzel, "Zeiss-Inform", 26, 8-13 (1981) No. 92.  
 W. Emmerich, Ch. Hofmann, "Jenaer Rundschau" Apr.  
 1986, pp. 193-196.  
 Smith, Warren et al., "Modern Lens Design" ISBN  
 0-07-059178-4 McGraw-Hill, 1992, Chapter 3.3.

\* cited by examiner

Fig. 1

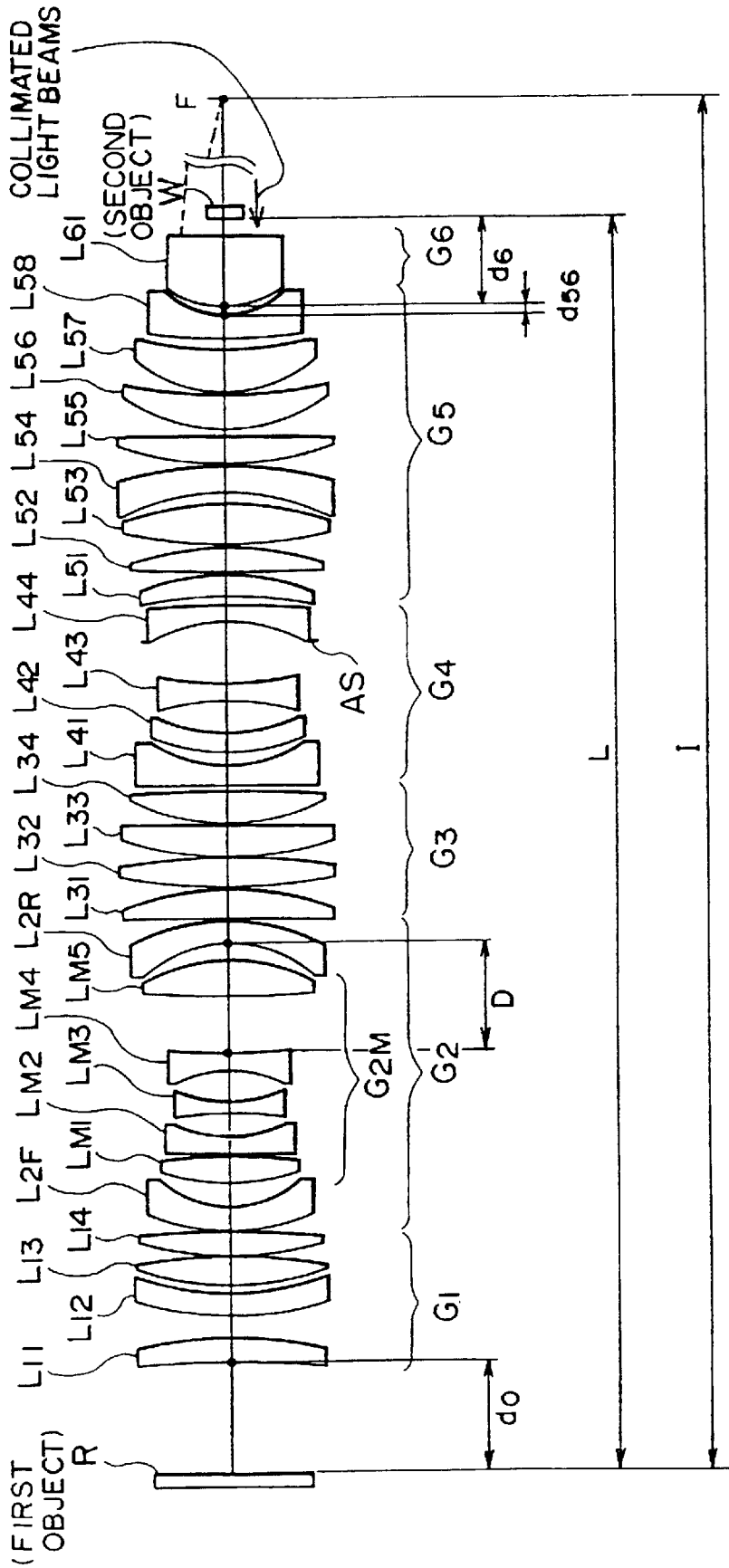

Fig. 2

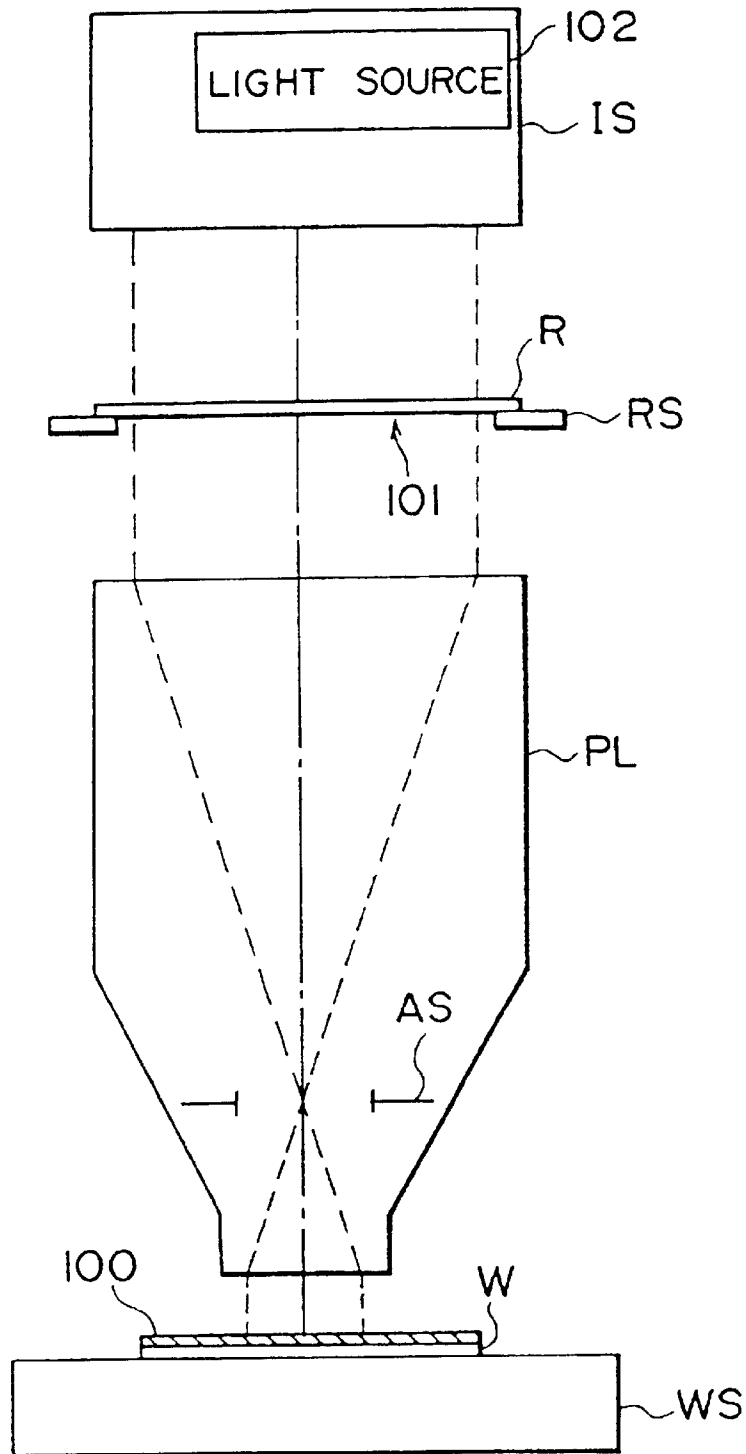

Fig. 3

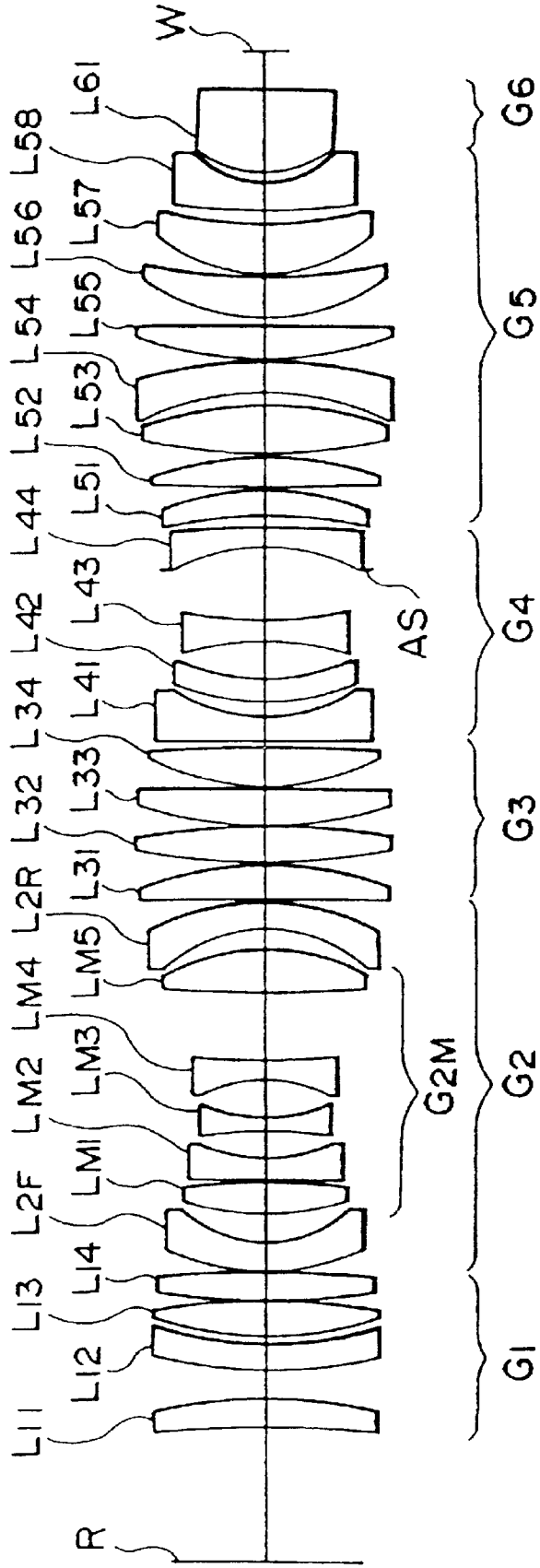

Fig. 4

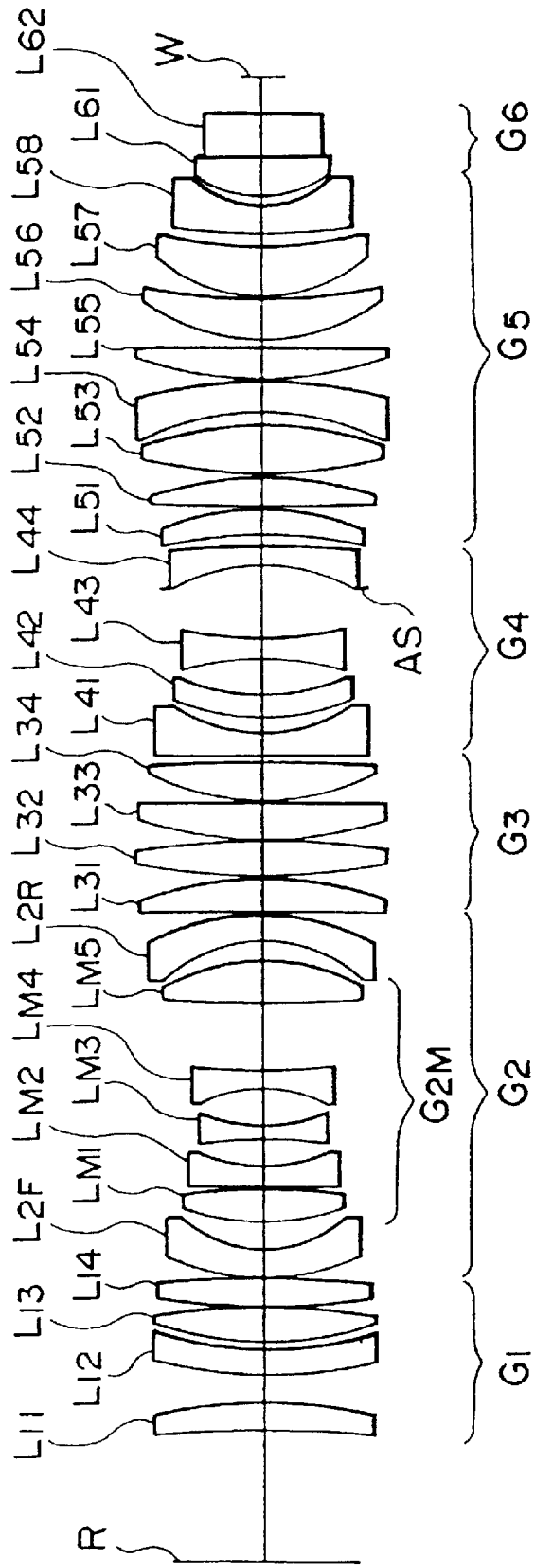

Fig. 5

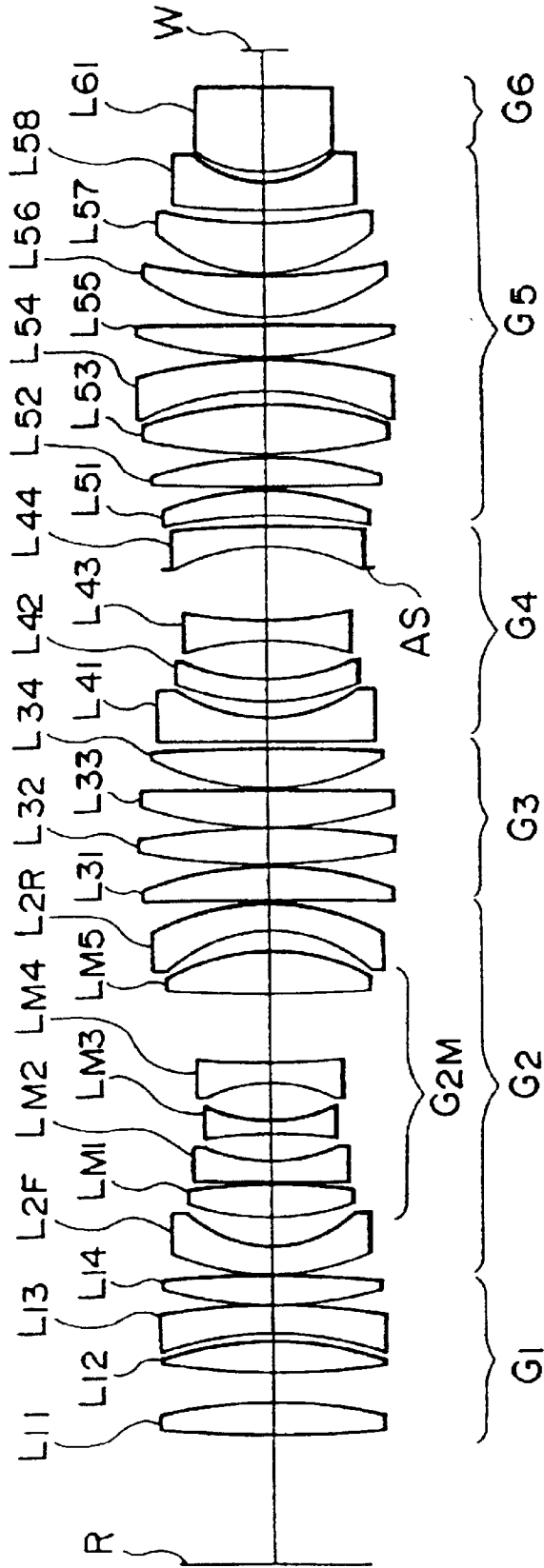

Fig. 6

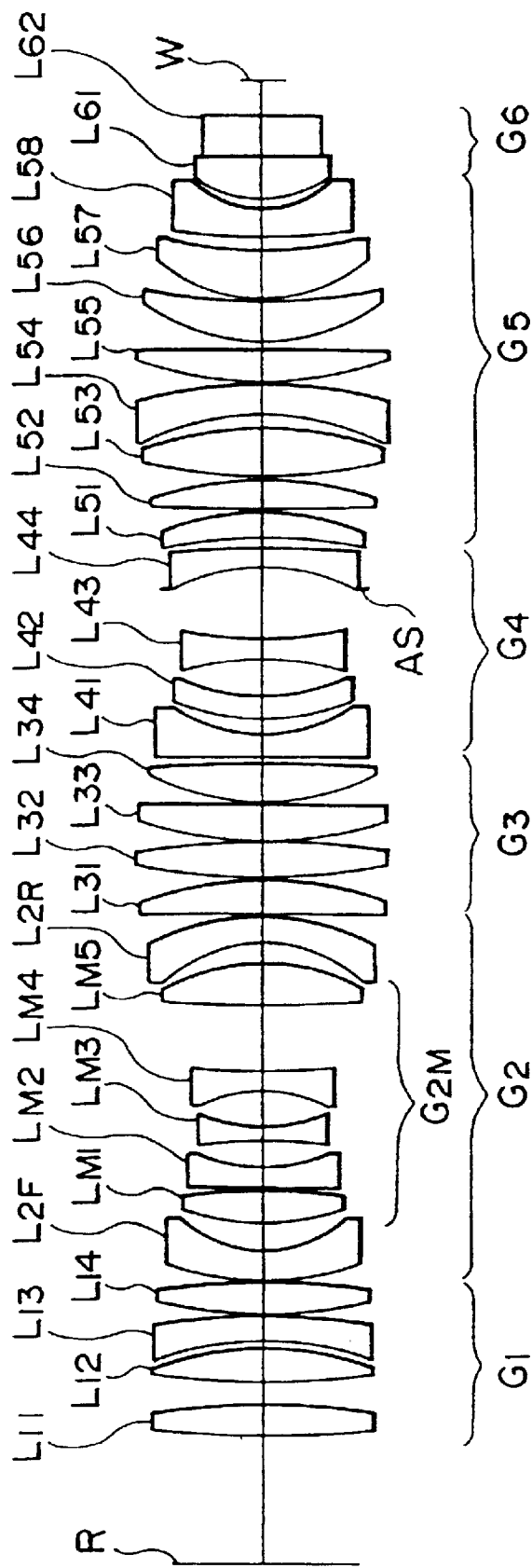

Fig. 7

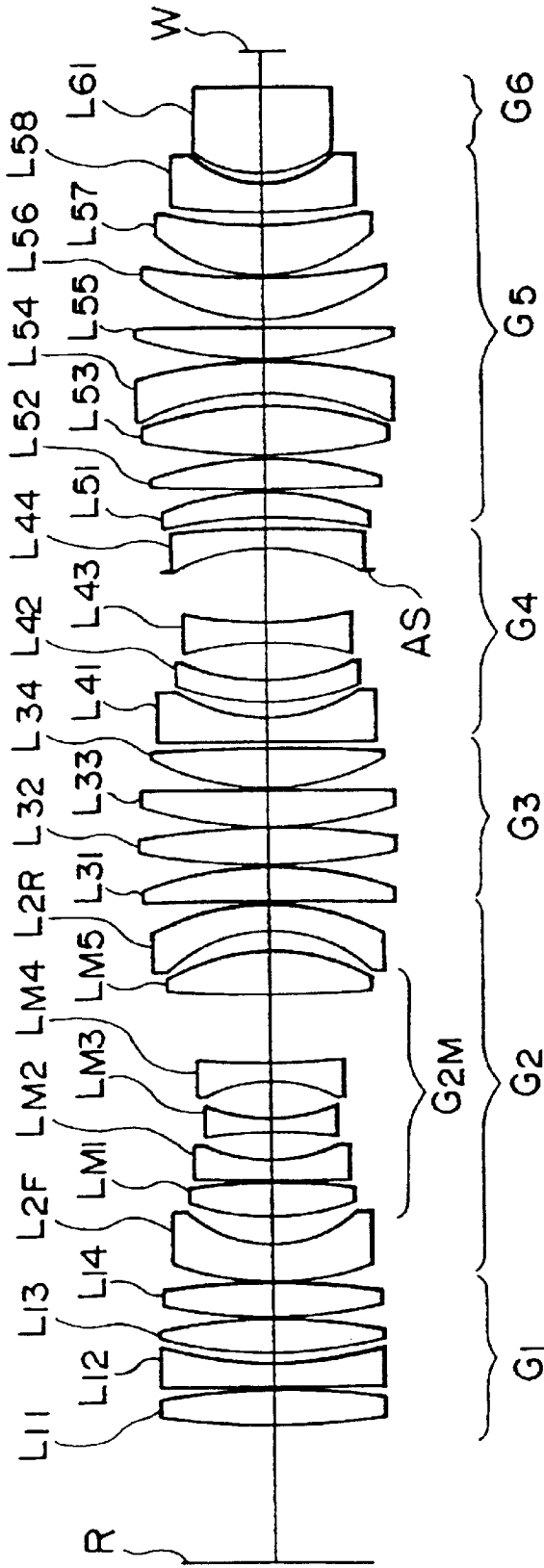

Fig. 8

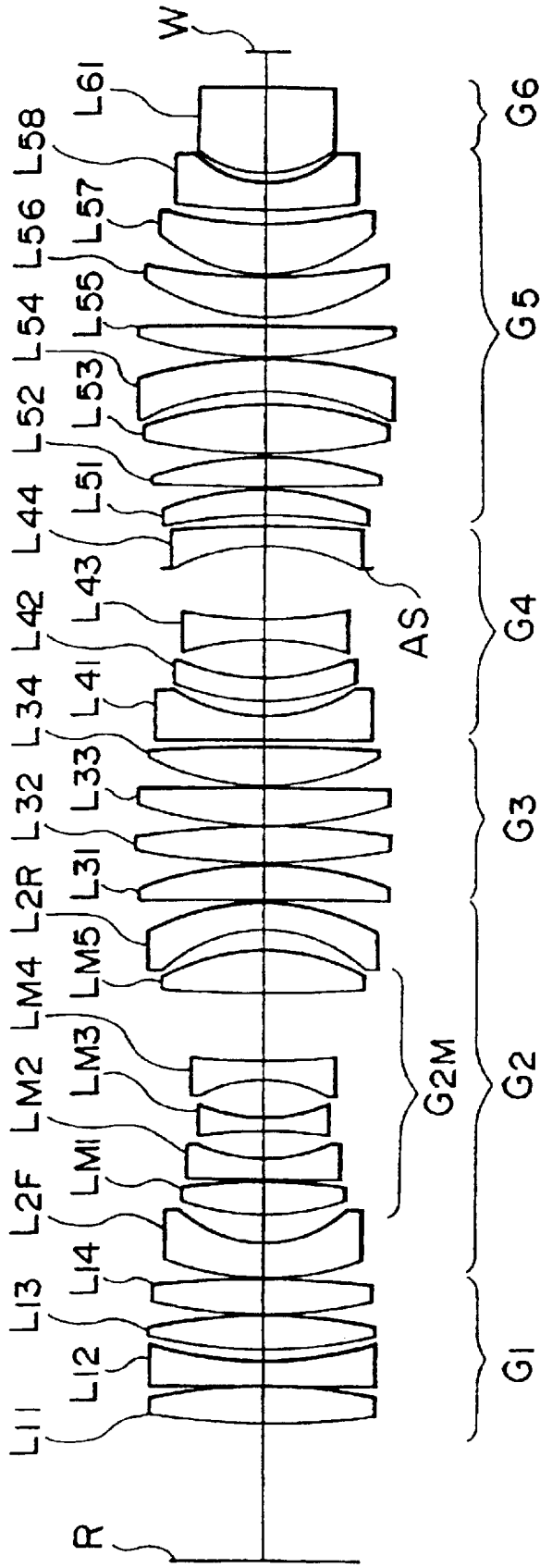

Fig. 9

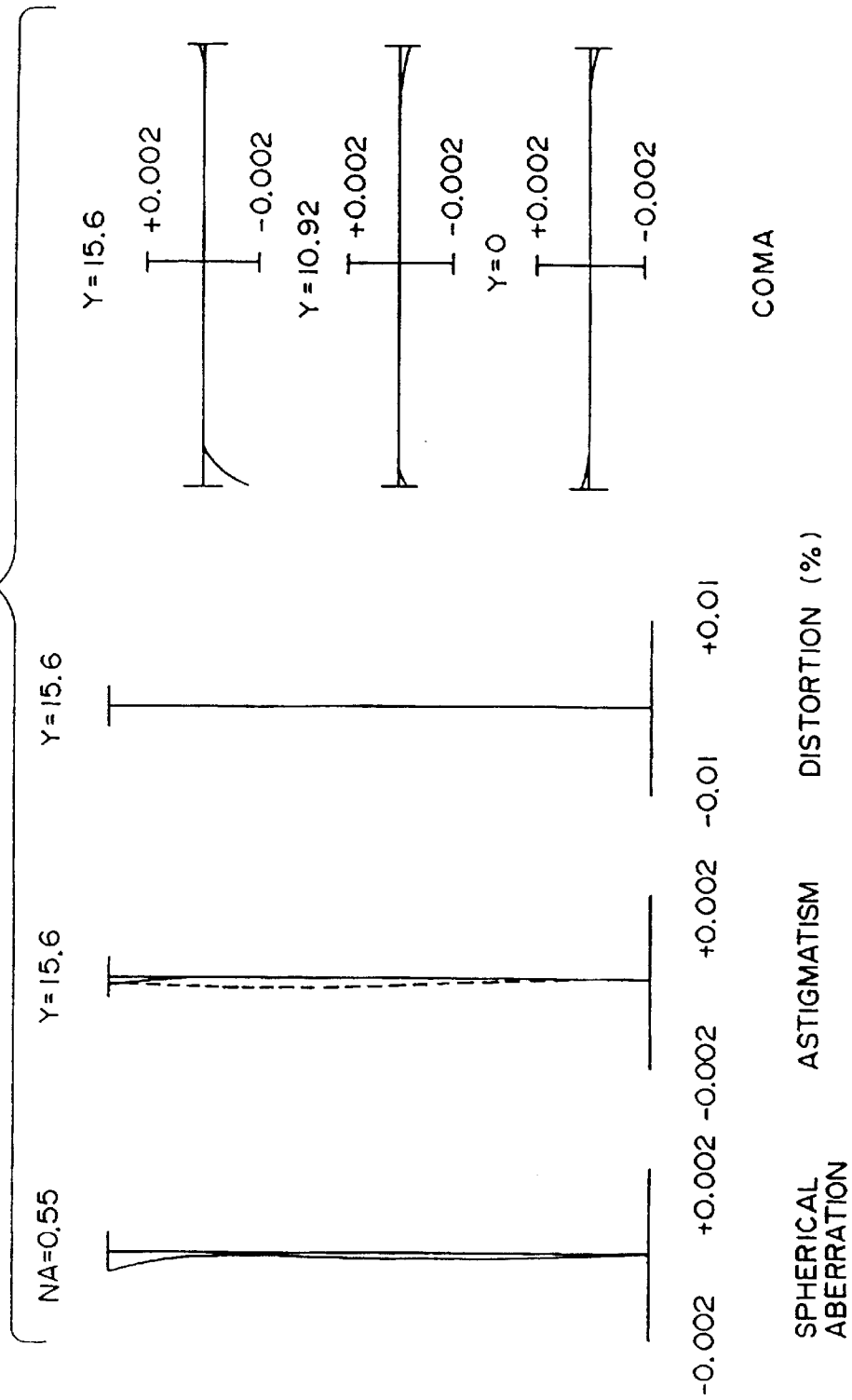

Fig. 10

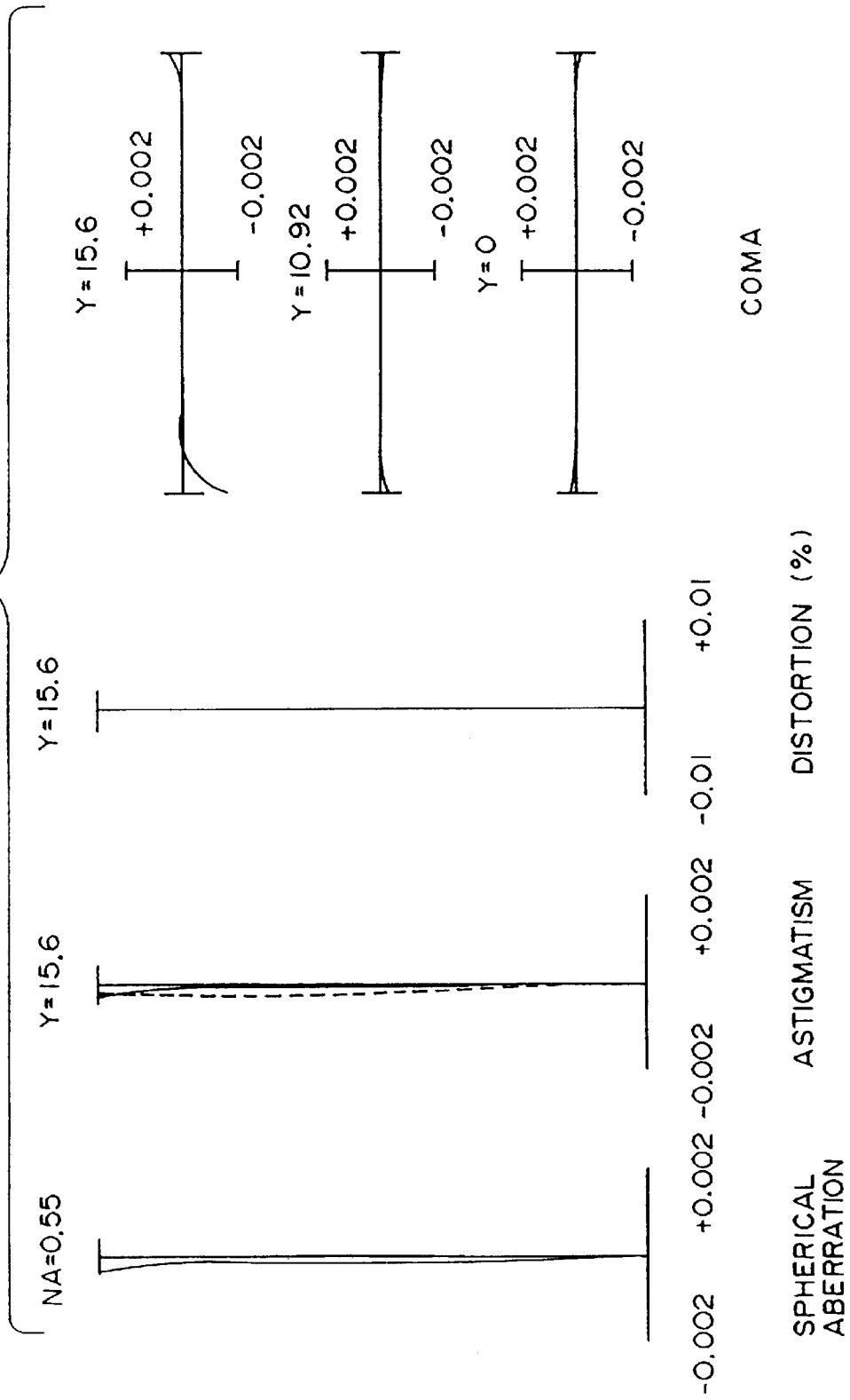

Fig. 11

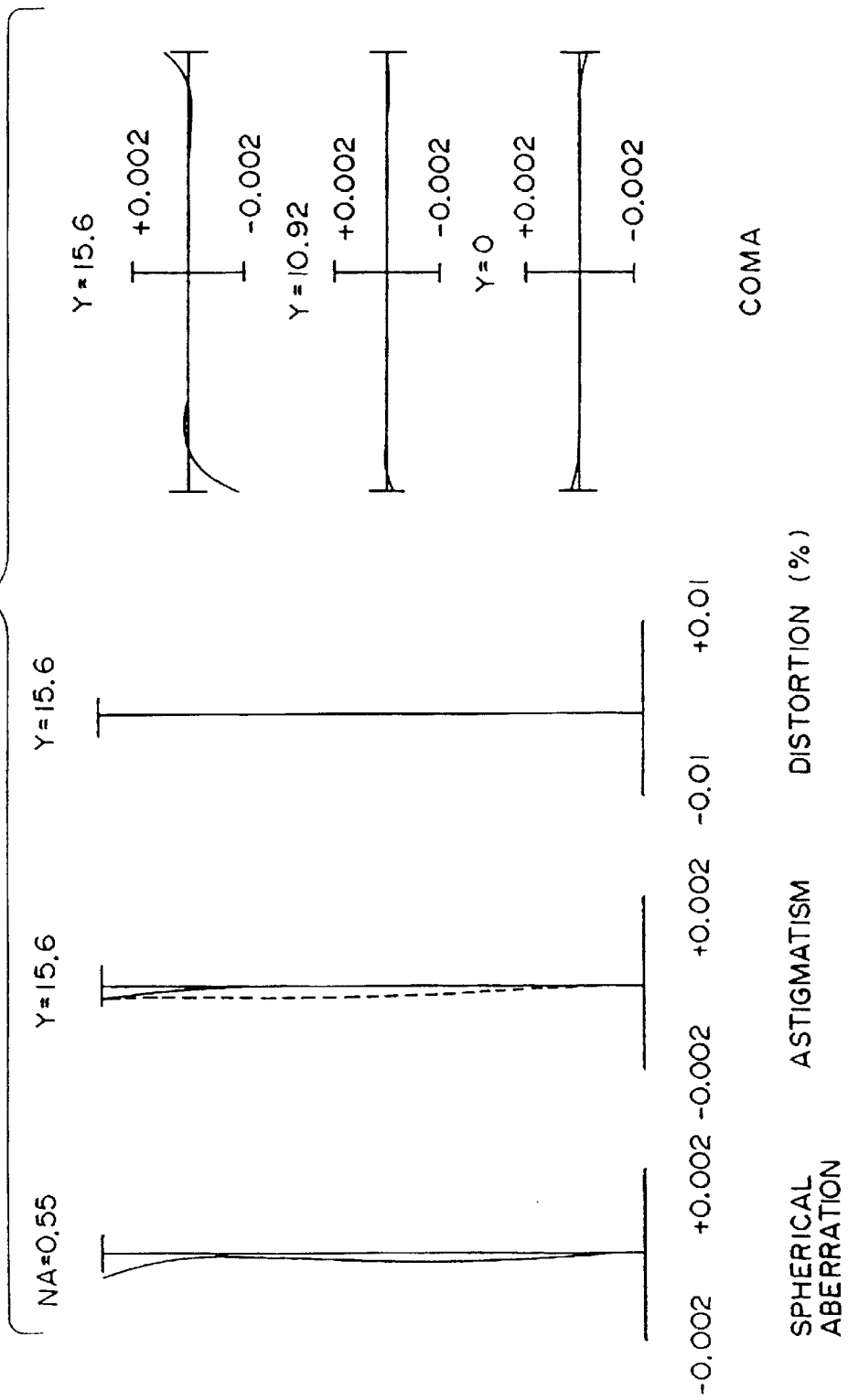

Fig. 12

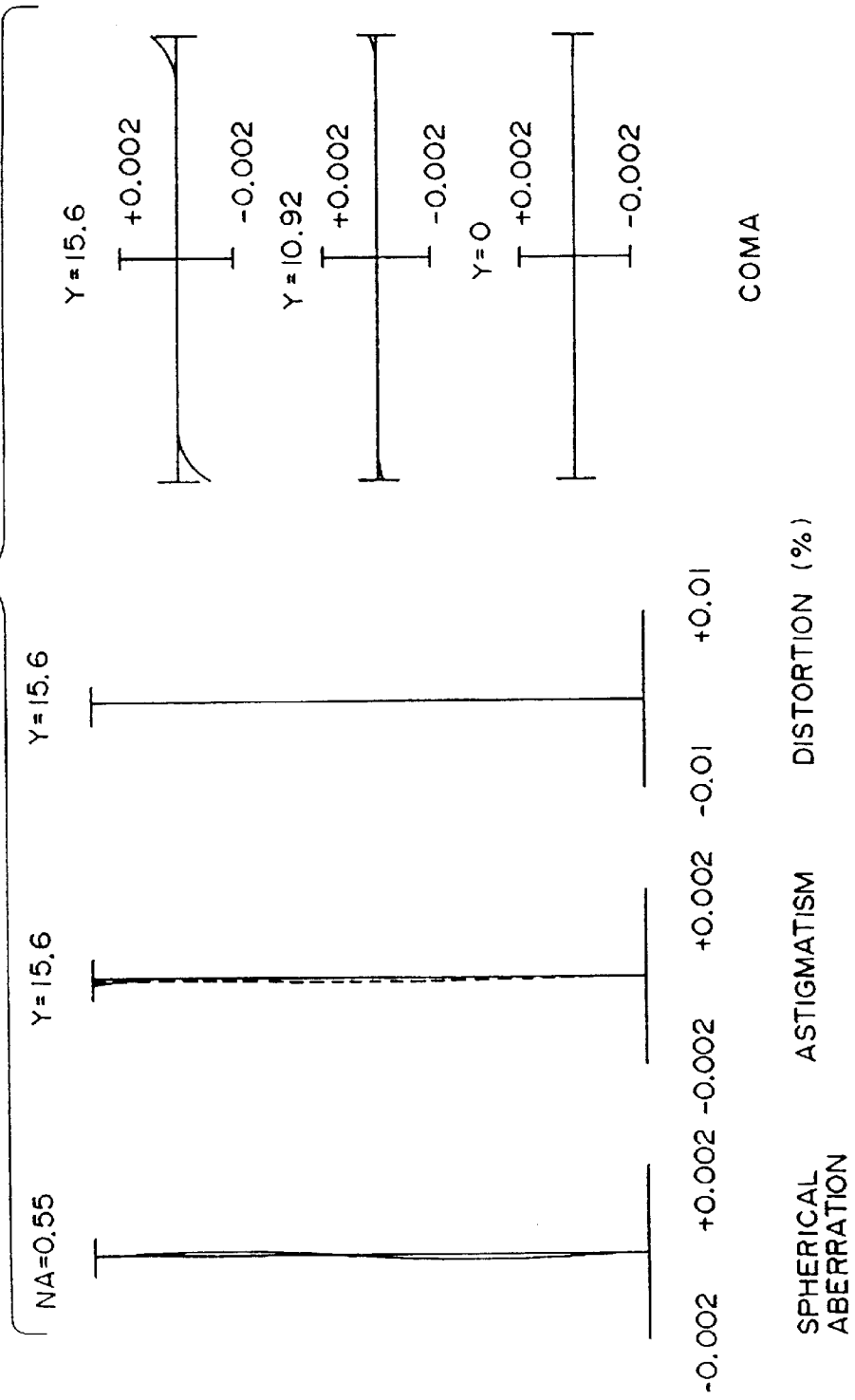

Fig. 13

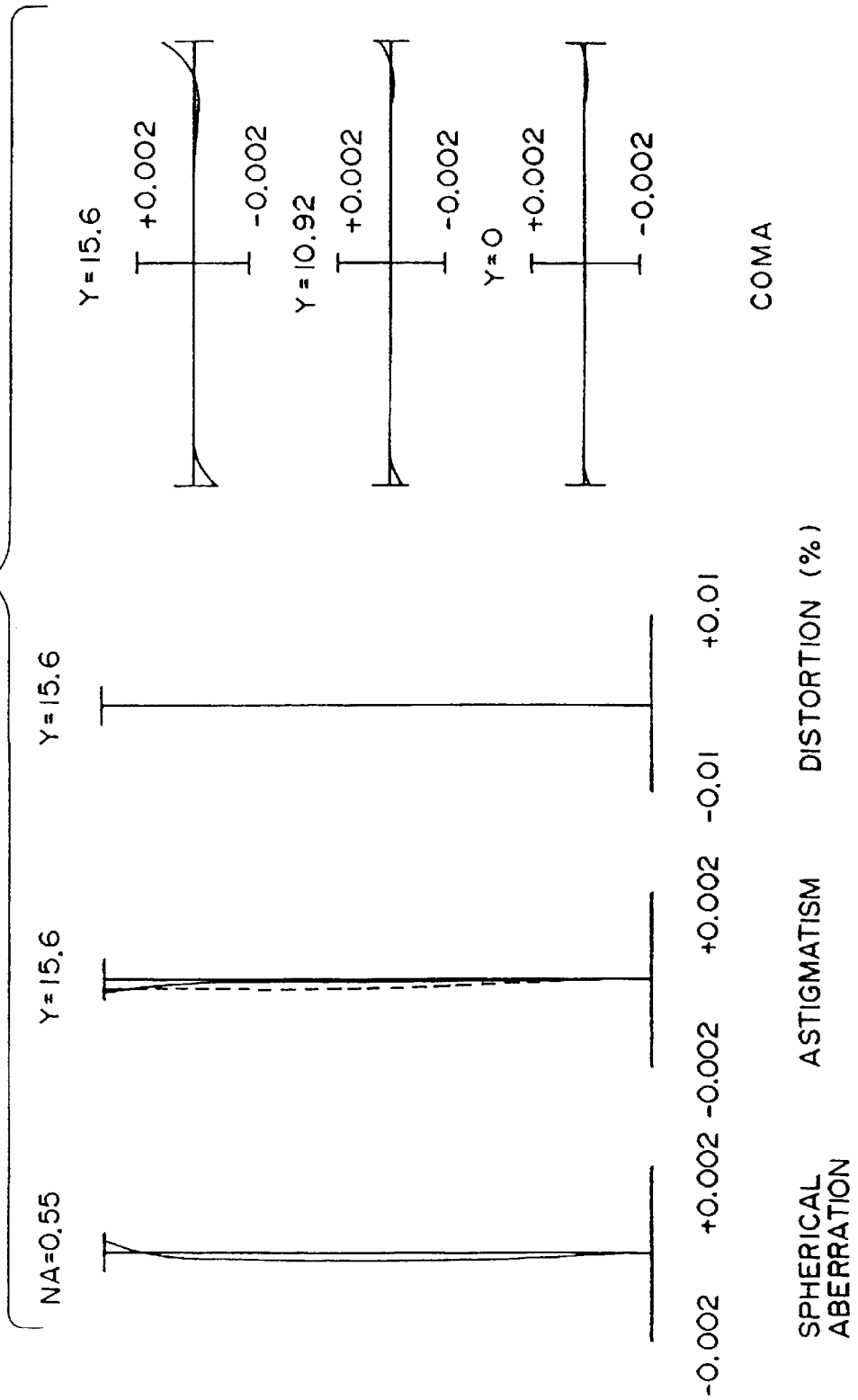
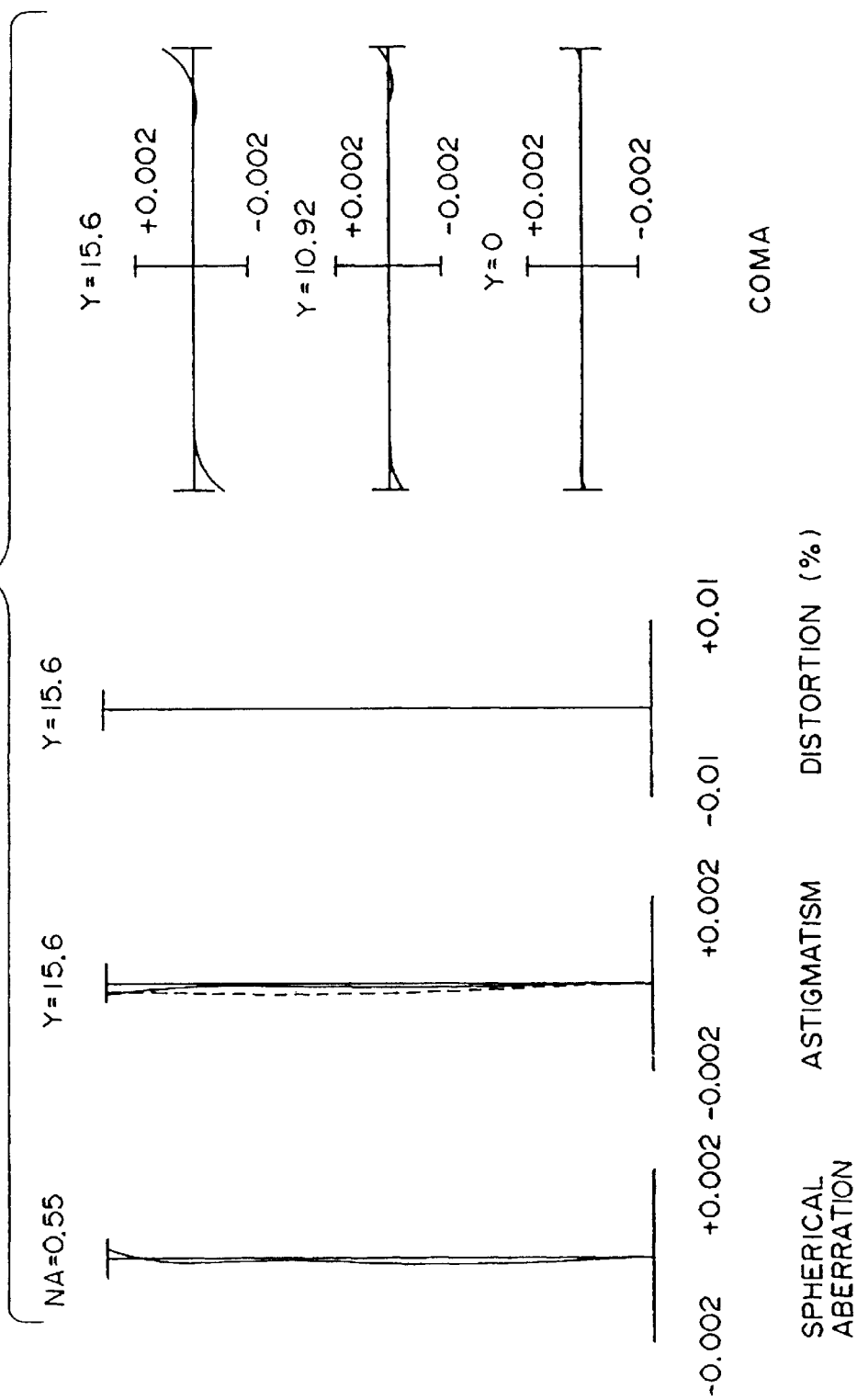

Fig. 14



## EXPOSURE APPARATUS

**Matter enclosed in heavy brackets [ ] appears in the original patent but forms no part of this reissue specification; matter printed in italics indicates the additions made by reissue.**

This is a continuation of application Ser. No. 08/706,761, filed Sep. 3, 1996, which is a continuation application of application Ser. No. 08/384,081, filed Feb. 6, 1995, both now abandoned.

## BACKGROUND OF THE INVENTION

## 1. Field of the Invention

The present invention relates to an exposure apparatus having a projection optical system for projecting a pattern of a first object onto a photosensitive substrate or the like as a second object, and more particularly to a projection optical system suitably applicable to projection exposure of a pattern for semiconductor or liquid crystal formed on a reticle (mask) as the first object onto the substrate (semiconductor wafer, plate, etc.) as the second object.

## 2. Related Background Art

As the patterns of integrated circuits become finer and finer, the resolving power required for the exposure apparatus used in printing of wafer also becomes higher and higher. In addition to the improvement in resolving power, the projection optical systems of the exposure apparatus are required to decrease image stress.

Here, the image stress includes those due to bowing or the like of the printed wafer on the image side of projection optical system and those due to bowing or the like of the reticle with circuit pattern written therein, on the object side of projection optical system, as well as distortion caused by the projection optical system.

With a recent further progress of fineness tendency of transfer patterns, demands for decreasing the image stress are also becoming greater.

In order to decrease effects of the wafer bowing on the image stress, the conventional technology has employed the so-called image-side telecentric optical system that locates the exit pupil position at a farther point on the image side of projection optical system.

On the other hand, the image stress due to the bowing of reticle can also be reduced by employing a so-called object-side telecentric optical system that locates the entrance pupil position of projection optical system at a farther point from the object plane, and there are suggestions to locate the entrance pupil position of projection optical system at a relatively far position from the object plane as described. Examples of those suggestions are described for example in Japanese Laid-open Patent Applications No. 63-118115 and No. 5-173065 and U.S. Pat. No. 5,260,832.

## SUMMARY OF THE INVENTION

An object of the invention is to provide an exposure apparatus having a high-performance projection optical system which can correct the aberrations, particularly the distortion, very well even in the bitelecentric arrangement while keeping a relatively wide exposure area and a large numerical aperture.

To achieve the above object, the present invention involves an exposure apparatus having a high-performance projection optical system comprising a stage allowing a photosensitive substrate (for example, a semiconductor wafer coated with a photosensitive material such as a

photoresist) to be held on a main surface thereof, an illumination optical system having a light source for emitting exposure light of a predetermined wavelength and transferring a predetermined pattern on a mask onto the substrate, and a projecting optical system for projecting an image of the mask, on the substrate surface. The above projecting optical system projects an image of a first object (for example, a mask with a pattern such as an integrated circuit) onto a second object (for example, a photosensitive substrate).

As shown in FIG. 1, the projection optical system has a first lens group  $G_1$  with positive refracting power, a second lens group  $G_2$  with negative refracting power, a third lens group  $G_3$  with positive refracting power, a fourth lens group  $G_4$  with negative refracting power, a fifth lens group  $G_5$  with positive refracting power, and a sixth lens group  $G_6$  with positive refracting power in the named order from the side of the first object R. The and the second lens group  $G_2$  further comprises a front lens  $L_{2F}$  placed as closest to the first object R and having negative refracting power with a concave surface to the second object W, a rear lens  $L_{2R}$  placed as closest to the second object and having negative refracting power with a concave surface to the first object R, and an intermediate lens group  $G_{2M}$  placed between the front lens  $L_{2F}$  in the second lens group  $G_2$  and the rear lens  $L_{2R}$  in the second lens group  $G_2$ . The intermediate lens group  $G_{2M}$  has a first lens  $L_{M1}$  with positive refracting power, a second lens  $L_{M2}$  with negative refracting power, a third lens  $L_{M3}$  with negative refracting power, and a fourth lens  $L_{M4}$  with negative refracting power in the named order from the side of the first object R.

First, the first lens group  $G_1$  with positive refracting power contributes mainly to a correction of distortion while maintaining telecentricity, and specifically, the first lens group  $G_1$  is arranged to generate a positive distortion to correct in a good balance negative distortions caused by the plurality of lens groups located on the second object side after the first lens group  $G_1$ . The second lens group  $G_2$  with negative refracting power and the fourth lens group  $G_4$  with negative refracting power contribute mainly to a correction of Petzval sum to make the image plane flat. The two lens groups of the second lens group  $G_2$  with negative refracting power and the third lens group  $G_3$  with positive refracting power form an inverse telescopic system to contribute to guarantee of back focus (a distance from an optical surface such as a lens surface closest to the second object W in the projection optical system to the second object W) in the projection optical system. The fifth lens group  $G_5$  with positive refracting power and the sixth lens group  $G_6$  similarly with positive refracting power contribute mainly to suppressing generation of distortion and suppressing generation particularly of spherical aberration as much as possible in order to fully support high NA structure on the second object side.

Based on the above structure, the front lens  $L_{2F}$  placed as closest to the first object R in the second lens group  $G_2$  and having the negative refracting power with a concave surface to the second object W contributes to corrections of curvature of field and coma, and the rear lens  $L_{2R}$  placed as closest to the second object W in the second lens group  $G_2$  and having the negative refracting power with a concave surface to the first object R to corrections of curvature of field, coma, and astigmatism. In the intermediate lens group  $G_{2M}$  placed between the front lens  $L_{2F}$  and the rear lens  $L_{2R}$ , the first lens  $L_{M1}$  with positive refracting power contributes to a correction of negative distortions caused by the second to fourth lenses  $L_{M2}$ - $L_{M4}$  with negative refracting power greatly contributing to the correction of curvature of field.

In particular, in the above projecting optical system, the following conditions (1) to (5) are satisfied when a focal length of the first lens group  $G_1$  is  $f_1$ , a focal length of the second lens group  $G_2$  is  $f_2$ , a focal length of the third lens group  $G_3$  is  $f_3$ , a focal length of the fourth lens group  $G_4$  is  $f_4$ , a focal length of the fifth lens group  $G_5$  is  $f_5$ , a focal length of the sixth lens group  $G_6$  is  $f_6$ , an overall focal length of the second to the fourth lenses  $L_{M2}$ - $L_{M4}$  in the intermediate lens group  $G_{2M}$  in the second lens group  $G_2$  is  $f_n$ , and a distance from the first object R to the second object W is L:

$$0.1 < f_1/f_3 < 1.7 \tag{1}$$

$$0.1 < f_2/f_4 < 1.4 \tag{2}$$

$$0.1 < f_5/L < 0.9 \tag{3}$$

$$0.1 < f_6/L < 1.6 \tag{4}$$

$$0.1 < f_n/f_2 < 2.0 \tag{5}$$

The condition (1) defines an optimum ratio between the focal length  $f_1$  of the first lens group  $G_1$  with positive refracting power and the focal length  $f_3$  of the third lens group  $G_3$  with positive refracting power, which is an optimum refracting power (power) balance between the first lens group  $G_1$  and the third lens group  $G_3$ . This condition (1) is mainly for correcting the distortion in a good balance. Below the lower limit of this condition (1) a large negative distortion is produced because the refracting power of the third lens group  $G_3$  becomes relatively weak to the refracting power of the first lens group  $G_1$ . Above the upper limit of the condition (1) a large negative distortion is produced because the refracting power of the first lens group  $G_1$  becomes relatively weak to the refracting power of the third lens group  $G_3$ .

The condition (2) defines an optimum ratio between the focal length  $f_2$  of the second lens group  $G_2$  with negative refracting power and the focal length  $f_4$  of the fourth lens group  $G_4$  with negative refracting power, which is an optimum refracting power (power) balance between the second lens group  $G_2$  and the fourth lens group  $G_4$ . This condition (2) is mainly for keeping the Petzval sum small so as to correct the curvature of field well while securing a wide exposure field. Below the lower limit of the condition (2), a large positive Petzval sum appears because the refracting power of the fourth lens group  $G_4$  becomes relatively weak to the refracting power of the second lens group  $G_2$ . Above the upper limit of the condition (2) a large positive Petzval sum appears because the refracting power of the second lens group  $G_2$  becomes relatively weak to the refracting power of the fourth lens group  $G_4$ . In order to correct the Petzval sum in a better balance under a wide exposure field by making the refracting power of the fourth lens group  $G_4$  strong relative to the refracting power of the second lens group  $G_2$ , the lower limit of the above condition (2) is preferably set to 0.8, i.e.,  $0.8 < f_2/f_4$ .

The condition (3) defines an optimum ratio between the focal length  $f_5$  of the fifth lens group  $G_5$  with positive refracting power and the distance (object-image distance) L from the first object R (reticle or the like) and the second object W (wafer or the like). This condition (3) is for correcting the spherical aberration, distortion, and Petzval sum in a good balance while keeping a large numerical aperture. Below the lower limit of this condition (3) the refracting power of the fifth lens group  $G_5$  is too strong, so that this fifth lens group  $G_5$  generates not only a negative distortion but also a great negative spherical aberration. Above the upper limit of this condition (3) the refracting

power of the fifth lens group  $G_5$  is too weak, so that the refracting power of the fourth lens group  $G_4$  with negative refracting power inevitably also becomes weak therewith, thereby resulting in failing to correct the Petzval sum well. The condition (4) defines an optimum ratio between the focal length  $f_6$  of the sixth lens group  $G_6$  with positive refracting power and the distance (object-image distance) L from the first object R (reticle etc.) to the second object W (wafer or the like). This condition (4) is for suppressing generation of higher-order spherical aberrations and negative distortion while keeping a large numerical aperture. Below the lower limit of this condition (4) the sixth lens group  $G_6$  itself produces a large negative distortion; above the upper limit of this condition (4) higher-order spherical aberrations appear.

The condition (5) defines an optimum ratio between the overall focal length  $f_n$  of the second lens  $L_{M2}$  with negative refracting power to the fourth lens  $L_{M4}$  with negative refracting power in the intermediate lens group  $G_{2M}$  in the second lens group  $G_2$  and the focal length  $f_2$  of the second lens group  $G_2$ . It should be noted that the overall focal length  $f_n$ , stated herein, of the second lens  $L_{M2}$  with negative refracting power to the fourth lens  $L_{M4}$  with negative refracting power in the intermediate lens group  $G_{2M}$  in the second lens group  $G_2$  means not only an overall focal length of three lenses, i.e., the second lens  $L_{M2}$  to the fourth lens  $L_{M4}$ , but also an overall focal length of three or more lenses between the second lens  $L_{M2}$  and the fourth lens  $L_{M4}$  where there are a plurality of lenses between the second lens and the fourth lens.

This condition (5) is for keeping the Petzval sum small while suppressing generation of distortion. Below the lower limit of this condition (5), a great negative distortion appears because the overall refracting power becomes too strong, of the negative sublens group including at least three negative lenses of from the second negative lens  $L_{M2}$  to the fourth negative lens  $L_{M4}$  in the intermediate lens group  $G_{2M}$  in the second lens group  $G_2$ . In order to sufficiently correct the distortion and coma, the lower limit of the above condition (5) is preferably set to 0.1, i.e.,  $0.1 < f_n/f_2$ .

Above the upper limit of this condition (5) a great positive Petzval sum results because the refracting power of the negative sublens group including at least three negative lenses of from the second negative lens  $L_{M2}$  to the fourth negative lens  $L_{M4}$  in the intermediate lens group  $G_{2M}$  in the second lens group  $G_2$  becomes too weak. In addition, the refracting power of the third lens group  $G_3$  also becomes weak. Thus, it becomes difficult to construct the projection optical system in a compact arrangement. In order to achieve a sufficiently compact design while well correcting the Petzval sum, the upper limit of the above condition (5) is preferably set to 1.3, i.e.,  $f_n/f_2 < 1.3$ .

Further, the following condition (6) is preferably satisfied when the axial distance from the first object R to the first-object-side focal point F of the entire projection optical system is I and the distance from the first object R to the second object W is L.

$$1.0 < I/L \tag{6}$$

The condition (6) defines an optimum ratio between the axial distance I from the first object R to the first-object-side focal point F of the entire projection optical system and the distance (object-image distance) L from the first object R (reticle or the like) to the second object W (wafer or the like). Here, the first-object-side focal point F of the entire projection optical system means an intersecting point of outgoing light from the projection optical system with the optical axis

after collimated light beams are let to enter the projection optical system on the second object side in the paraxial region with respect to the optical axis of the projection optical system and when the light beams in the paraxial region are outgoing from the projection optical system.

Below the lower limit of this condition (6) the first-object-side telecentricity of the projection optical system will become considerably destroyed, so that changes of magnification and distortion due to an axial deviation of the first object R will become large. As a result, it becomes difficult to faithfully project an image of the first object R at a desired magnification onto the second object W. In order to fully suppress the changes of magnification and distortion due to the axial deviation of the first object R, the lower limit of the above condition (6) is preferably set to 1.7, i.e.,  $1.7 < I/L$ . Further, in order to correct a spherical aberration and a distortion of the pupil both in a good balance while maintaining the compact design of the projection optical system, the upper limit of the above condition (6) is preferably set to 6.8, i.e.,  $I/L < 6.8$ .

Also, it is more preferable that the following condition (7) be satisfied when the focal length of the third lens  $L_3$ , with negative refracting power in the intermediate lens group  $G_{2M}$  in the second lens group  $G_2$  is  $f_{23}$  and the focal length of the fourth lens  $L_{M4}$  with negative refracting power in the intermediate lens group  $G_{2M}$  in the second lens group  $G_2$  is  $f_{24}$ .

$$0.07 < f_{24}/f_{23} < 7. \quad (7)$$

Below the lower limit of the condition (7) the refracting power of the fourth negative lens  $L_{M4}$  becomes strong relative to the refracting power of the third negative lens  $L_{M3}$  so that the fourth negative lens  $L_{M4}$  generates a large coma and a large negative distortion. In order to correct the coma better while correcting the negative distortion, the lower limit of the above condition (7) is preferably set to 0.14, i.e.,  $0.14 < f_{24}/f_{23}$ . Above the upper limit of this condition (7) the refracting power of the third negative lens  $L_{M3}$  becomes relatively strong relative to the refracting power of the fourth negative lens  $L_{M4}$ , so that the third negative lens  $L_{M3}$  generates a large coma and a large negative distortion. In order to correct the negative distortion better while correcting the coma, the upper limit of the above condition (7) is preferably set to 3.5, i.e.,  $f_{24}/f_{23} < 3.5$ .

Further, it is more preferable that the following condition (8) be satisfied when the focal length of the second lens  $L_{M2}$  with negative refracting power in the intermediate lens group  $G_{2M}$  in the second lens group  $G_2$  is  $f_{22}$  and the focal length of the third lens  $L_{M3}$  with negative refracting power in the intermediate lens group  $G_{2M}$  in the second lens group  $G_2$  is  $f_{23}$ .

$$0.1 < f_{22}/f_{23} < 10 \quad (8)$$

Below the lower limit of the condition (8) the refracting power of the second negative lens  $L_{M2}$  becomes strong relative to the refracting power of the third negative lens  $L_{M3}$ , so that the second negative lens  $L_{M2}$  generates a large coma and a large negative distortion. In order to correct the negative distortion in a better balance, the lower limit of the above condition (8) is preferably set to 0.2, i.e.,  $0.24 < f_{22}/f_{23}$ . Above the upper limit of this condition (8) the refracting power of the third negative lens  $L_{M3}$  becomes strong relative to the refracting power of the second negative lens  $L_{M2}$ , so that the third negative lens  $L_{M3}$  generates a large coma and a large negative distortion. In order to correct the negative distortion in a better balance while well correcting the coma,

the upper limit of the above condition (8) is preferably set to 5, i.e.,  $f_{22}/f_{23} < 5$ .

Also, it is more desirable that the following condition (9) be satisfied when the axial distance from the second-object-side lens surface of the fourth lens  $L_{M4}$  with negative refracting power in the intermediate lens group  $G_{2M}$  in the second lens group  $G_2$  to the first-object-side lens surface of the rear lens  $L_{2R}$  in the second lens group  $G_2$  is D and the distance from the first object R to the second object W is L:

$$0.05 < D/L < 0.4. \quad (9)$$

Below the lower limit of the condition (9) it becomes difficult not only to secure a sufficient back focus on the second object side but also to correct the Petzval sum well. Above the upper limit of the condition (9) a large coma and a large negative distortion appear. Further, for example, in order to avoid mechanical interference between a reticle stage for holding the reticle as the first object R and the first lens group  $G_1$ , there are cases that it is preferable to secure a sufficient space between the first object R and the first lens group  $G_1$ , but there is a problem that to secure the sufficient space will become difficult above the upper limit of the condition (9).

Also, the fourth lens group  $G_4$  preferably satisfies the following condition when the focal length of the fourth lens group  $G_4$  is  $f_4$  and the distance from the first object R to the second object W is L.

$$-0.98 < f_4/L < -0.005 \quad (10)$$

Below the lower limit of the condition (10) the correction of spherical aberration becomes difficult, which is not preferable. Also, above the upper limit of the condition (10), the coma appears, which is not preferable. In order to well correct the spherical aberration and Petzval sum, the lower limit of the condition (10) is preferably set to  $-0.078$ , i.e.,  $-0.078 < f_4/L$ , and further, in order to suppress generation of coma, the upper limit of the condition (10) is preferably set to  $-0.047$ , i.e.,  $f_4/L < -0.047$ .

Further, the second lens group  $G_2$  preferably satisfies the following condition when the focal length of the second lens group  $G_2$  is  $f_2$  and the distance from the first object R to the second object W is L.

$$-0.8 < f_2/L < -0.005 \quad (11)$$

Here; below the lower limit of the condition (11), a positive Petzval sum results, which is not preferable. Also, above the upper limit of the condition (11), a negative distortion appears, which is not preferable. In order to better correct the Petzval sum, the lower limit of the condition (11) is preferably set to  $-0.16$ , i.e.,  $-0.16 < f_2/L$ , and in order to better correct the negative distortion and coma, the upper limit of the condition (11) is preferably set to  $-0.0710$ , i.e.,  $f_2/L < -0.0710$ .

In order to well correct mainly the third-order spherical aberration, it is more desirable that the fifth lens group  $G_5$  with positive refracting power have the negative meniscus lens  $L_{54}$ , and the positive lens  $L_{54}$  placed adjacent to the concave surface of the negative meniscus lens  $L_{54}$  and having a convex surface opposed to the concave surface of the negative meniscus lens  $L_{54}$  and that the following condition (12) be satisfied when the radius of curvature of the concave surface in the negative meniscus lens  $L_{54}$  in the fifth lens group  $G_5$  is  $r_{5n}$  and the radius of curvature of the convex surface opposed to the concave surface of the negative meniscus lens  $L_{54}$  in the positive lens  $L_{53}$  set

adjacent to the concave surface of the negative meniscus lens  $L_{54}$  in the fifth lens group  $G_5$  is  $r_{5p}$ .

$$0 < (r_{5p} - r_{5n}) / (r_{5p} + r_{5n}) < 1 \tag{12}$$

Below the lower limit of the condition (12), correction of the third-order spherical aberration becomes insufficient; conversely, above the upper limit of the condition (12), the correction of the third-order spherical aberration becomes excessive, which is not preferable. Here, in order to correct the third-order spherical aberration better, the lower limit of the condition (12) is more preferably set to 0.01, i.e.,  $0.01 < (r_{5p} - r_{5n}) / (r_{5p} + r_{5n})$  and the upper limit of the condition (12) is more preferably set to 0.7, i.e.,  $(r_{5p} - r_{5n}) / (r_{5p} + r_{5n}) < 0.7$ .

Here, it is preferred that the negative meniscus lens and the positive lens adjacent to the concave surface of the negative meniscus lens be set between the at least one positive lens in the fifth lens group  $G_5$  and the at least one positive lens in the fifth lens group  $G_5$ . For example, a set of the negative meniscus lens  $L_{54}$  and the positive lens  $L_{53}$  is placed between the positive lenses  $L_{52}$  and  $L_{55}$ . This arrangement can suppress generation of the higher-order spherical aberrations which tend to appear with an increase in NA.

Also, it is more desirable that the fourth lens group  $G_4$  with negative refracting power have the front lens  $L_{41}$  placed as closest to the first object R and having the negative refracting power with a concave surface to the second object W, the rear lens  $L_{44}$  placed as closest to the second object W and having the negative refracting power with a concave surface to the first object R, and at least one negative lens placed between the front lens  $L_{41}$  in the fourth lens group  $G_4$  and the rear lens  $L_{44}$  in the fourth lens group  $G_4$  and that the following condition (13) be satisfied when a radius of curvature on the first object side in the rear lens  $L_{44}$  placed as closest to the second object W in the fourth lens group  $G_4$  is  $r_{4F}$  and a radius of curvature on the second object side in the rear lens  $L_{44}$  placed as closest to the second object W in the fourth lens group  $G_4$  is  $r_{4R}$ .

$$-1.00 \leq (r_{4F} - r_{4R}) / (r_{4F} + r_{4R}) < 0 \tag{13}$$

Below the lower limit of the condition (13), the rear negative lens  $L_{44}$  located closest to the second object W in the fourth lens group  $G_4$  becomes of a double-concave shape, which generates higher-order spherical aberrations; conversely, above the upper limit of the condition (13), the rear negative lens  $L_{44}$  located closest to the second object W in the fourth lens group  $G_4$  will have positive refracting power, which will make the correction of Petzval sum more difficult.

Further, it is desirable that the fifth lens group  $G_5$  have the negative lens  $L_{58}$  with a concave surface to the second object W, on the most second object side thereof. This enables the negative lens  $L_{58}$  located closest to the second object W in the fifth lens group  $G_5$  to generate a positive distortion and a negative Petzval sum, which can cancel a negative distortion and a positive Petzval sum generated by the positive lenses in the fifth lens group  $G_5$ .

In this case, in order to suppress the negative distortion without generating the higher-order spherical aberrations in the lens  $L_{61}$  located closest to the first object R in the sixth lens group  $G_6$ , it is desirable that the lens surface closest to the first object R have a shape with a convex surface to the first object R and that the following condition be satisfied when a radius of curvature on the second object side, of the negative lens  $L_{58}$  placed as closest to the second object W

in the fifth lens group  $G_5$  is  $r_{5R}$  and a radius of curvature on the first object side, of the lens  $L_{61}$  placed as closest to the first object R in the sixth lens group  $G_6$  is  $r_{6F}$ .

$$-0.90 < (r_{5R} - r_{5F}) / (r_{5R} + r_{5F}) < -0.001 \tag{14}$$

This condition (14) defines an optimum shape of a gas lens formed between the fifth lens group  $G_5$  and the sixth lens group  $G_6$ . Below the lower limit of this condition (14) a curvature of the second-object-side concave surface of the negative lens  $L_{58}$  located closest to the second object W in the fifth lens group  $G_5$  becomes too strong, thereby generating higher-order comas. Above the upper limit of this condition (14) refracting power of the gas lens itself formed between the fifth lens group  $G_5$  and the sixth lens group  $G_6$  becomes weak, so that a quantity of the positive distortion generated by this gas lens becomes small, which makes it difficult to well correct a negative distortion generated by the positive lenses in the fifth lens group  $G_5$ . In order to fully suppress the generation of higher-order comas, the lower limit of the above condition (14) is preferably set to -0.30, i.e.,  $-0.30 < (r_{5R} - r_{6F}) / (r_{5R} + r_{6F})$ .

Also, it is further preferable that the following condition be satisfied when a lens group separation between the fifth lens group  $G_5$  and the sixth lens group  $G_6$  is  $d_{56}$  and the distance from the first object R to the second object W is L.

$$d_{54}L < 0.017 \tag{15}$$

Above the upper limit of this condition (15), the lens group separation between the fifth lens group  $G_5$  and the sixth lens group  $G_6$  becomes too large, so that a quantity of the positive distortion generated becomes small. As a result, it becomes difficult to correct the negative distortion generated by the positive lens in the fifth lens group  $G_5$  in a good balance.

Also, it is more preferable that the following condition be satisfied when a radius of curvature of the lens surface closest to the first object R in the sixth lens group  $G_6$  is  $r_{6F}$  and an axial distance from the lens surface closest to the first object R in the sixth lens group  $G_6$  to the second object W is  $d_6$ .

$$0.50 < d_6 / r_{6F} < 1.50 \tag{16}$$

Below the lower limit of this condition (16), the positive refracting power of the lens surface closest to the first object R in the sixth lens group  $G_6$  becomes too strong, so that a large negative distortion and a large coma are generated. Above the upper limit of this condition (16), the positive refracting power of the lens surface closest to the first object R in the sixth lens group  $G_6$  becomes too weak, thus generating a large coma. In order to further suppress the generation of coma, the lower limit of the condition (16) is preferably set to 0.84, i.e.,  $0.84 < d_6 / r_{6F}$ .

It is desirable that the following condition (17) be satisfied when the radius of curvature on the first object side in the negative lens  $L_{58}$  located closest to the second object W in the fifth lens group  $G_5$  is  $r_{5F}$  and the radius of curvature on the second object side in the negative lens  $L_{58}$  located closest to the second object W in the fifth lens group  $G_5$  is  $r_{5R}$ .

$$0.30 < (r_{5F} - r_{5R}) / (r_{5F} + r_{5R}) < 1.28 \tag{17}$$

Below the lower limit of this condition (17), it becomes difficult to correct both the Petzval sum and the coma; above the upper limit of this condition (17), large higher-order comas appear, which is not preferable. In order to further

prevent the generation of higher-order comas, the upper limit of the condition (17) is preferably set to 0.93, i.e.,  $(r_{5F}-r_{5R})/(r_{5F}+r_{5R})<0.93$ .

Further, it is desirable that the second-object-side lens surface of the first lens  $L_{M1}$  with positive refracting power in the intermediate lens group  $G_{2M}$  in the second lens group  $G_2$  be of a lens shape with a convex surface to the second object W, and in this case, it is more preferable that the following condition (18) be satisfied when the refracting power on the second-object-side lens surface of the first positive lens  $L_{M1}$  in the intermediate lens group  $G_{2m}$  in the second lens group  $G_2$  is  $\Phi_{21}$  and the distance from the first object R to the second object W is L.

$$0.54<1/(\Phi_{21}L)<10 \tag{18}$$

The refracting power of the second-object-side lens surface, stated herein, of the first lens  $L_{M1}$  with positive refracting power in the intermediate lens group  $G_{2M}$  is given by the following formula when a refractive index of a medium for the first lens  $L_{M1}$  is  $n_1$ , a refractive index of a medium in contact with the second-object-side lens surface of the first lens  $L_{M1}$  is  $n_2$ , and a radius of curvature of the second-object-side lens surface of the first lens is  $r_{21}$ .

$$\Phi_{21}=(n_2-n_1)/r_{21} \tag{19}$$

Below the lower limit of the condition (18), higher-order distortions appear; conversely, above the upper limit of the condition (18), it becomes necessary to correct the distortion more excessively by the first lens group  $G_1$ , which generates the spherical aberration of the pupil, thus being not preferable.

Further, it is more preferable that the following condition (19) be satisfied when the focal length of the first lens  $L_{M1}$  with positive refracting power in the intermediate lens group  $G_{2M}$  in the second lens group  $G_2$  is  $f_{21}$  and the distance from the first object R to the second object W is L.

$$0.230<f_{21}/L<0.40 \tag{19}$$

Below the lower limit of the condition (19), a positive distortion appears; above the upper limit of the condition (19), a negative distortion appears, thus not preferable.

Also, the front lens  $L_{2F}$  and rear lens  $L_{2R}$  in the second lens group  $G_2$  preferably satisfy the following condition when the focal length of the front lens  $L_{2F}$  placed as closest to the first object R in the second lens group  $G_2$  and having the negative refracting power with a concave surface to the second object W is  $f_{2F}$  and the focal length of the rear lens  $L_{2R}$  placed as closest to the second object W in the second lens group  $G_2$  and having the negative refracting power with a concave surface to the first object R is  $f_{2R}$ .

$$0f_{2F}/f_{2R}<18 \tag{20}$$

The condition (20) defines an optimum ratio between the focal length  $f_{2R}$  of the rear lens  $L_{2R}$  in the second lens group  $G_2$  and the focal length  $f_{2F}$  of the front lens  $L_{2F}$  in the second lens group  $G_2$ . Below the lower limit and above the upper limit of this condition (20), a balance is destroyed for refracting power of the first lens group  $G_1$  or the third lens group  $G_3$ , which makes it difficult to correct the distortion well or to correct the Petzval sum and the astigmatism simultaneously well.

The following specific arrangements are desirable to provide the above respective lens groups with sufficient aberration control functions.

First, in order to provide the first lens group  $G_1$  with a function to suppress generation of higher-order distortions

and spherical aberration of the pupil, the first lens group  $G_1$  preferably has at least two positive lenses; in order to provide the third lens group  $G_3$  with a function to suppress degradation of the spherical aberration and the Petzval sum, the third lens group  $G_3$  preferably has at least three positive lenses; further, in order to provide the fourth lens group  $G_4$  with a function to suppress the generation of coma while correcting the Petzval sum, the fourth lens group  $G_4$  preferably has at least three negative lenses. Further, in order to provide the fifth lens group  $G_5$  with a function to suppress generation of the negative distortion and the spherical aberration, the fifth lens group  $G_5$  preferably has at least five positive lenses; further, in order to provide the fifth lens group  $G_5$  with a function to correct the negative distortion and the Petzval sum, the fifth lens group  $G_5$  preferably has at least one negative lens. Also, in order to provide the sixth lens group  $G_6$  with a function to converge light on the second object W without generating a large spherical aberration, the sixth lens group  $G_6$  preferably has at least one positive lens.

In addition, in order to correct the Petzval sum better, the intermediate lens group  $G_2$  in the second lens group  $G_2$  preferably has negative refracting power.

In order to provide the sixth lens group  $G_6$  with a function to further suppress the generation of the negative distortion, the sixth lens group  $G_6$  is preferably constructed of three or less lenses having at least one surface satisfying the following condition (21).

$$1/|\Phi L|<20 \tag{21}$$

where  $\Phi$ : refracting power of the lens surface;

L: object-image distance from the first object R to the second object W.

The refracting power of the lens surface stated herein is given by the following formula when the radius of curvature of the lens surface is r, a refractive index of a medium on the first object side, of the lens surface is  $n_1$ , and a medium on the second object side, of the lens surface is  $n_2$ .

$$\Phi=(n_2-n_1)/r$$

Here, if there are four or more lenses having the lens surface satisfying this condition (21), the number of lens surfaces with some curvature, located near the second object W, becomes increased, which generates the distortion, thus not preferable.

The present invention will become more fully understood from the detailed description given hereinbelow and the accompanying drawings which are given by way of illustration only, and thus are not to be considered as limiting the present invention.

Further scope of applicability of the present invention will become apparent from the detailed description given hereinafter. However, it should be understood that the detailed description and specific examples, while indicating preferred embodiments of the invention, are given by way of illustration only, since various changes and modifications within the spirit and scope of the invention will become apparent to those skilled in the art from this detailed description.

BRIEF DESCRIPTION OF THE DRAWINGS

FIG. 1 is drawing to show parameters defined in embodiments of the present invention.

FIG. 2 is a drawing to show schematic structure of an exposure apparatus according to the present invention.

FIG. 3 is a lens makeup diagram in the first embodiment according to the present invention.

FIG. 4 is a lens makeup diagram in the second embodiment according to the present invention.

FIG. 5 is a lens makeup diagram in the third embodiment according to the present invention.

FIG. 6 is a lens makeup diagram in the fourth embodiment according to the present invention.

FIG. 7 is a lens makeup diagram in the fifth embodiment according to the present invention.

FIG. 8 is a lens makeup diagram in the sixth embodiment according to the present invention.

FIG. 9 is various aberration diagrams in the first embodiment according to the present invention.

FIG. 10 is various aberration diagrams in the second embodiment according to the present invention.

FIG. 11 is various aberration diagrams in the third embodiment according to the present invention.

FIG. 12 is various aberration diagrams in the fourth embodiment according to the present invention.

FIG. 13 is various aberration diagrams in the fifth embodiment according to the present invention.

FIG. 14 is various aberration diagrams in the sixth embodiment according to the present invention.

#### DETAILED DESCRIPTION OF THE PREFERRED EMBODIMENTS

The embodiments according to the present invention will be described in detail in the following. An exposure apparatus of the invention comprises a projection optical system as shown in FIG. 2.

First, briefly describing FIG. 2, a reticle R (first object) is placed as a mask on which a predetermined circuit pattern 101 is formed, on the object plane of a projection optical system PL and a wafer W (second object) as a photosensitive substrate on the image plane of the projection optical system PL, as shown. The reticle R is held on a reticle stage RS while the wafer W on a wafer stage WS. The photosensitive substrate comprises the wafer W and a photosensitive layer 100 made of a material as a photoresistor. Further, an illumination optical system IS, which has a light source 102 for emitting exposure light of a predetermined wavelength, for uniformly illuminating the reticle R is set above the reticle R.

In the above arrangement, light supplied from the illumination optical system IS illuminates the reticle R to form an image of a light source in the illumination optical apparatus IS at the pupil position (or a position of aperture stop AS) of the projection optical system PL, thus achieving the so-called Kohler illumination. Then, through the projection optical system PL, a pattern image of the thus Köhler-illuminated reticle R is projected (or transferred) onto the wafer W through the photosensitive layer 100 by the projection optical system PL. The techniques relating to an exposure apparatus of the present invention are described for example in U.S. Pat. No. 5,194,993, U.S. Pat. No. 5,097,291 and U.S. Pat. No. 5,245,384 and U.S. patent application Ser. No. 299,305, U.S. patent application Ser. No. 255,927 and U.S. patent application Ser. No. 226,327.

The present embodiment shows an example of projection optical system where the light source 102 inside the illumination optical system IS is an excimer laser supplying light with exposure wavelength  $\lambda$  of 248.4 nm, and FIG. 3 to FIG. 8 are lens makeup diagrams of projection optical systems in the first to sixth embodiments according to the present invention.

As shown in FIG. 3 to FIG. 8, a projection optical system in each embodiment has a first lens group  $G_1$  with positive refracting power, a second lens group  $G_2$  with negative refracting power, a third lens group  $G_3$  with positive refracting power, a fourth lens group  $G_4$  with negative refracting power, a fifth lens group  $G_5$  with positive refracting power, and a sixth lens group  $G_6$  with positive refracting power in the named order from the side of reticle R as the first object, which is approximately telecentric on the object side (or on the reticle R side) and on the image side (or on the wafer W side) and which has a reduction magnification.

The projection optical systems of the respective embodiments shown in FIG. 3 to FIG. 8 are arranged so that the object-image distance (a distance from the object plane to the image plane or a distance from the reticle R to the wafer W) L is 1200, the image-side numerical aperture NA is 0.55, the projection magnification B is 5:1, and the diameter of the exposure area on the wafer W is 31.2. In the explanation of embodiments of the present invention, the image plane means a main surface of the wafer W, and the object plane means a surface of the reticle R.

The lens makeup of the first embodiment, as shown in FIG. 3, is specifically described. The first lens group  $G_1$  has a positive lens  $L_{11}$  with a convex surface to the image (positive meniscus lens), a negative lens  $L_{12}$  of a meniscus shape with a convex surface to the object, and two positive lenses ( $L_{13}$ ,  $L_{14}$ ) of a double-convex shape in the named order from the object side.

Next, the second lens group  $G_2$  is composed of a negative meniscus lens (front lens)  $L_{2F}$  placed as closest to the object with a concave surface to the image, a negative meniscus lens (rear lens)  $L_{2R}$  placed closest to the image with a concave surface to the object, and an intermediate lens group  $G_{2M}$  placed between the negative meniscus lens  $L_{2R}$  located closest to the object in the second lens group  $G_2$  and the negative meniscus lens  $L_{2F}$  located closest to the image in the second lens group  $G_2$ , and having negative refracting power.

The intermediate lens group  $G_{2M}$  is composed of a positive lens (first lens)  $LV_{31}$  of a double-convex shape, a negative lens (second lens)  $L_{M2}$  with a surface of a greater curvature to the image, a negative lens (third lens)  $L_{M3}$  of a double-concave shape, a negative lens (fourth lens)  $L_{M4}$  with a surface of a greater curvature to the object, and a positive lens (fifth lens)  $L_{M5}$  with a surface of a greater curvature to the image in the named order from the object side.

Further, the third lens group  $G_3$  is composed of a positive lens (positive meniscus lens)  $L_{31}$  with a surface of a greater curvature to the image, a positive lens  $L_{32}$  of a double-convex shape, a positive lens (a positive lens of a double-convex shape)  $L_{33}$  with a convex surface to the object, and a positive lens  $L_{34}$  with a surface of a greater curvature to the object, and the fourth lens group  $G_4$  is composed of a negative lens (negative meniscus lens)  $L_{41}$  with a concave surface to the image, a negative meniscus lens  $L_{42}$  with a concave surface to the image, a negative lens  $L_{43}$  of a double concave surface, and a negative meniscus lens  $L_{44}$  with a concave surface to the object.

Here, an aperture stop AS is set in an optical path between the image-side concave surface of the negative lens  $L_{41}$  in the fourth lens group  $G_4$  and the object-side concave surface of the negative meniscus lens  $L_{44}$ .

The fifth lens group  $G_5$  is composed of a positive meniscus lens  $L_{51}$  with a convex surface to the image, a positive lens with a surface of a greater curvature to the image (a

positive lens of a double-convex shape)  $L_{52}$ , a positive lens  $L_{33}$  of a double-convex shape, a negative meniscus lens  $L_{34}$  with a concave surface to the object, a positive lens  $L_{55}$  with a surface of a greater curvature to the object, a positive meniscus lens  $L_{56}$  with a convex surface to the object, a positive lens with a surface of a greater curvature to the object (positive meniscus lens)  $L_{57}$ , and a negative lens with a concave surface to the image (negative meniscus lens)  $L_{58}$ , and the sixth lens group  $G_6$  is composed only of a thick-wall positive lens  $L_{61}$  with a convex surface to the object.

Here, because the first lens group  $G_1$  in the first embodiment is so arranged that the image-side lens surface of the negative lens  $L_{12}$  of the meniscus shape with its convex surface to the object and the object-side lens surface of the positive lens  $L_{13}$  of double-convex shape have nearly equal curvatures and are arranged as relatively close to each other, these two lens surfaces correct the higher-order distortions.

In the present embodiment, because the front lens  $L_{33}$  with negative refracting power, placed closest to the object in the second lens group  $G_2$ , is of the meniscus shape with a concave surface to the image, the generation of coma can be reduced; because the first lens  $L_{M1}$  with positive refracting power in the second lens group  $G_{2M}$  is of the double-convex shape with a convex surface to the image and another convex surface to the object, the generation of spherical aberration of the pupil can be suppressed. Further, because the fifth lens  $L_{M5}$  with positive refracting power in the intermediate lens group  $G_{2M}$  has the convex surface opposed to the concave surface of the rear lens  $L_{2R}$  with negative refracting power placed on the image side thereof, the astigmatism can be corrected.

Since the fourth lens group  $G_4$  is so arranged that the negative lens  $L_{41}$  with its concave surface to the image is placed on the object side of the negative lens (negative lens of double-concave shape)  $L_{43}$  and that the negative meniscus lens  $L_{44}$  with its concave surface to the object is placed on the image side of the negative lens (negative lens of double-concave shape)  $L_{43}$ , the Petzval sum can be corrected while suppressing the generation of coma.

The present embodiment is so arranged that the aperture stop AS is placed between the image-side concave surface of the negative lens  $L_{41}$  and the object-side concave surface of the negative meniscus lens  $L_{44}$  in the fourth lens group  $G_4$  whereby the lens groups of from the third lens group  $G_3$  to the sixth lens group  $G_6$  can be arranged on either side of the aperture stop AS with some reduction magnification and without destroying the symmetry so much, which can suppress generation of asymmetric aberrations, specifically generation of coma or distortion.

Since the positive lens  $L_{53}$  in the fifth lens group  $G_5$  is of the double-convex shape where its convex surface is opposed to the negative meniscus lens  $L_{54}$  and the other lens surface opposite to the negative meniscus lens  $L_{54}$  is also a convex surface, the generation of higher-order spherical aberrations with an increase in NA can be suppressed.

The specific lens makeup of the projection optical system in the second embodiment as shown in FIG. 4 is similar to that of the first embodiment shown in FIG. 3 and described above but different in that the fourth lens group  $G_4$  is composed of a negative lens with a concave surface to the image (negative lens of a plano-concave shape)  $L_{41}$ , a negative meniscus lens  $L_{42}$  with a concave surface to the image, a negative lens  $L_{43}$  of a double-concave shape, and a negative meniscus lens  $L_{44}$  with a concave surface to the object and in that the sixth lens group  $G_6$  is composed of a positive lens with a convex surface to the object (positive

meniscus lens)  $L_{61}$ , and a positive lens with a convex surface to the object (positive meniscus lens)  $L_{62}$ .

Also in the second embodiment, the image-side lens surface of the negative meniscus lens  $L_{12}$  with its convex surface to the object and the object-side lens surface of the positive lens  $L_{13}$  of double-convex shape correct the higher-order distortions, similarly as in the above first embodiment. Further, the sixth lens group  $G_6$  is preferably composed of a less number of constituent lenses in order to suppress a distortion generated by the sixth lens group  $G_6$ , but if it is difficult to produce a thick lens the sixth lens group  $G_6$  may be composed of two lenses as in the present embodiment. As for the other lens groups (the second lens group  $G_1$  to the fifth lens group  $G_5$ ) in the second embodiment, the same functions as in the first embodiment are achieved thereby.

The specific lens makeup of the projection optical system of the third embodiment as shown in FIG. 5 is similar to that of the first embodiment shown in FIG. 3 and described previously, but different in that the first lens group  $G_1$  is composed of a positive lens with a convex surface to the image (positive lens of double-convex shape)  $L_{11}$ , a positive lens with a convex surface to the image (positive lens of double-convex shape)  $L_{12}$ , a negative meniscus lens  $L_{13}$  with a concave surface to the object, and a positive lens  $L_{14}$  of double-convex shape in the named order from the object side and in that the third lens group  $G_3$  is composed of a positive lens with a surface of a greater curvature to the image (positive meniscus lens)  $L_{31}$ , a positive lens  $L_{32}$  of double-convex shape, a positive lens with a surface of a greater curvature to the object (positive lens of double-convex shape)  $L_{33}$ , and a positive lens with a convex surface to the object (positive meniscus lens)  $L_{34}$ .

In the third embodiment, the image-side lens surface of the positive lens  $L_{12}$  with its convex surface to the image and the object-side lens surface of the negative meniscus lens  $L_{13}$  with its concave surface to the object correct the higher-order distortions. As for the other lens groups (the second lens group  $G_2$ , and the fourth lens group  $G_4$  to the sixth lens group  $G_6$ ) in the third embodiment, the same functions as in the first embodiment are achieved thereby.

The specific lens makeup of the projection optical system of the fourth embodiment as shown in FIG. 6 is similar to that of the third embodiment shown in FIG. 5 and described above, but different in that the third lens group  $G_3$  is composed of a positive lens with a surface of a greater curvature to the image side (positive meniscus lens)  $L_{31}$ , a positive lens  $L_{32}$  of double-convex shape, a positive lens with a convex surface to the object (positive lens of double-convex shape)  $L_{33}$ , and a positive lens with a surface of a greater curvature to the object (positive lens of double-convex shape)  $L_{34}$ , and in that the fourth lens group  $G_4$  is composed of a negative lens with a concave surface to the image (negative lens of double-concave shape)  $L_{41}$ , a negative meniscus lens  $L_{42}$  with a concave surface to the image, a negative lens  $L_{43}$  of double-concave shape, and a negative meniscus lens  $L_{44}$  with a concave surface to the object. The present embodiment is also different in that the sixth lens group  $G_6$  is composed of a positive lens with a convex surface to the object (positive meniscus lens)  $L_{61}$  and a positive lens with a convex surface to the object (positive meniscus lens)  $L_{62}$ .

The first lens group  $G_1$  in the fourth embodiment achieves the same functions as in the third embodiment described previously, the second lens group  $G_2$  to the fifth lens group  $G_5$  do the same functions as in the first embodiment, and the sixth lens group  $G_6$  does the same functions as in the second embodiment.

The specific lens makeup of the projection optical system of the fifth embodiment shown in FIG. 7 is similar to that of the first embodiment shown in FIG. 3 and described previously, but different in that the first lens group  $G_1$  is composed of a positive lens with a convex surface to the image (positive lens of double-convex shape)  $L_{11}$ , a negative lens with a concave surface to the image (negative lens of double-concave shape)  $L_{12}$  and two positive lenses ( $L_{13}$ ,  $L_{14}$ ) of double-convex shape in the named order from the object side. It is also different in that the third lens group  $G_3$  is composed of a positive lens with a surface of a greater curvature to the image (positive meniscus lens)  $L_{31}$ , a positive lens  $L_{32}$  of double-convex shape, a positive lens with a convex surface to the object (positive meniscus lens)  $L_{33}$ , and a positive lens with a surface of a greater curvature to the object (positive lens of double-convex shape)  $L_{34}$ . It is also different from the lens makeup of the first embodiment in that the fourth lens group  $G_4$  is composed of a negative lens with a concave surface to the image (negative lens of double-concave shape)  $L_{41}$ , a negative meniscus lens  $L_{42}$  with a concave surface to the image, a negative lens  $L_{43}$  of double-concave shape, and a negative meniscus lens  $L_{44}$  with a concave surface to the object. It is further different in that the fifth lens group  $G_5$  is composed of a positive meniscus lens  $L_{51}$  with a convex surface to the image, a positive lens with a surface of a greater curvature to the image (positive meniscus lens)  $L_{52}$ , a positive lens  $L_{53}$  of double-convex shape, a negative meniscus lens  $L_{54}$  with a concave surface to the object, a positive lens with a surface of a greater curvature to the object (positive meniscus lens)  $L_{55}$ , a positive meniscus lens  $L_{56}$  with a convex surface to the object, a positive lens with a surface of a greater curvature to the object (positive meniscus lens)  $L_{57}$ , and a negative lens with a concave surface to the image (negative meniscus lens)  $L_{58}$ .

In the fifth embodiment the higher-order distortions are corrected by a pair of the image-side convex surface of the positive lens  $L_{11}$  and the object-side concave surface of the negative lens  $L_{12}$  and a pair of the image-side concave surface of the negative lens  $L_{12}$  and the object-side convex surface of the positive lens  $L_{13}$ . As for the other lens groups (the second to the fifth lens groups  $G_2$  to  $G_5$ ) in the fifth embodiment, the same functions as in the first embodiment are achieved thereby.

The sixth embodiment shown in FIG. 8 has the same lens makeup as that of the fifth embodiment as described above, and achieves the substantially same functions as in the fifth embodiment.

Now, Table 1 to Table 12 listed below indicate values of specifications and numerical values corresponding to the conditions in the respective embodiments according to the present invention.

In the tables, left end numerals represent lens surfaces located in the named order from the object side (reticle side),  $r$  curvature radii of lens surfaces,  $d$  lens surface separations,  $n$  refractive indices of synthetic quartz  $\text{SiO}_2$  for the exposure wavelength  $\lambda$  of 248.4 nm,  $d_0$  a distance from the first object (reticle) to the lens surface (first lens surface) closest to the object (reticle) in the first lens group  $G_1$ ,  $Bf$  a distance from the lens surface closest to the image (wafer) in the sixth lens group  $G_6$  to the image plane (wafer surface),  $B$  a projection magnification of the projection optical system,  $NA$  the image-side numerical aperture of the projection optical system,  $L$  the object-image distance from the object plane (reticle surface) to the image plane (wafer surface),  $I$  the axial distance from the first object (reticle) to the first-object-side focal point of the entire projection optical system

(where the first-object-side focal point of the entire projection optical system means an intersecting point of exit light with the optical axis after collimated light beams in the paraxial region with respect to the optical axis of the projection optical system are let to enter the projection optical system on the second object side and when the light beams in the paraxial region are outgoing from the projection optical system),  $f_1$  the focal length of the first lens group  $G_1$ ,  $f_2$  the focal length of the second lens group  $G_2$ ,  $f_3$  the focal length of the third lens group  $G_3$ ,  $f_4$  the focal length of the fourth lens group  $G_4$ ,  $f_5$  the focal length of the fifth lens group  $G_5$ ,  $f_6$  the focal length of the sixth lens group  $G_6$ ,  $f_n$  the overall focal length of from the second lens to the fourth lens,  $f_{2F}$  the focal length of the front lens placed closest to the first object in the second lens group and having negative refracting power with its concave surface to the second object,  $f_{2R}$  the focal length of the rear lens placed closest to the second object in the second lens group and having negative refracting power with its concave surface to the first object,  $f_{21}$  the focal length of the first lens with positive refracting power in the intermediate lens group in the second lens group,  $f_{22}$  the focal length of the second lens with negative refracting power in the second lens group,  $f_{23}$  the focal length of the third lens with negative refracting power in the second lens group,  $f_{24}$  the focal length of the fourth lens with negative refracting power in the second lens group,  $\Phi_{21}$  the refracting power of the second-object-side lens surface of the first lens with positive refracting power in the intermediate lens group  $G_{21}$  in the second lens group,  $D$  the axial distance from the second-object-side lens surface of the fourth lens in the intermediate lens group in the second lens group to the first-object-side lens surface of the rear lens in the second lens group,  $r_{5n}$  the curvature radius of the concave surface in the negative meniscus lens in the fifth lens group,  $r_{5p}$  the curvature radius of the convex surface opposed to the concave surface of the negative meniscus lens, in the positive lens placed adjacent to the concave surface of the negative meniscus lens in the fifth lens group,  $f_{4F}$  the first-object-side curvature radius in the rear lens placed closest to the second object in the fourth lens group,  $r_{4R}$  the second-object-side curvature radius in the rear lens placed closest to the second object in the fourth lens group,  $r_{5F}$  the first-object-side curvature radius in the second lens placed closest to the second object in the fifth lens group,  $r_{5R}$  the second-object-side curvature radius of the negative lens placed closest to the second object in the fifth lens group,  $r_{6F}$  the first-object-side curvature radius of the lens placed closest to the first object in the sixth lens group,  $d_{56}$  the lens group separation between the fifth lens group and the sixth lens group,  $d_6$  the axial distance from the lens surface closest to the first object in the sixth lens group to the second object, and  $\phi$  the refracting power of the lens surface of the lens or lenses forming the sixth lens group.

TABLE 1

First Embodiment			
		$d_0 = 105.33208$	
		$B = 1/5$	
		$NA = 0.55$	
		$Bf = 28.62263$	
		$L = 1200$	
	$r$	$d$	$n$
1	-821.91920	23.00000	1.50839
2	-391.93385	20.81278	
3	334.30413	20.00000	1.50839

TABLE 1-continued

First Embodiment			
	$d_o = 105.33208$		
	$B = 1/5$		
	$NA = 0.55$		
	$Bf = 28.62263$		
	$L = 1200$		
r	d	n	
4	239.01947	7.92536	
5	267.66514	28.00000	1.50839
6	-618.41676	1.04750	
7	337.90351	23.00000	1.50839
8	-1279.67000	0.97572	
9	200.03116	24.00000	1.50839
10	105.22457	22.04713	
11	219.65515	26.00000	1.50839
12	-546.12474	1.10686	
13	4788.40002	17.00000	1.50839
14	125.70412	20.76700	
15	-381.52610	12.90000	1.50839
16	134.36400	26.88549	
17	-127.38724	15.00000	1.50839
18	433.13808	52.33906	
19	1260.83000	35.00000	1.50839
20	-178.61526	14.91509	
21	-129.71674	22.80000	1.50839
22	-202.88016	2.79782	
23	-4128.12000	27.00000	1.50839
24	-299.28737	2.87255	
25	556.52963	28.00000	1.50839
26	-928.16848	2.49780	
27	367.82207	30.00000	1.50839
28	-4438.51001	1.64701	
29	220.29374	31.00000	1.50839
30	-1698.69000	3.60527	
31	4987.07001	21.00000	1.50839
32	146.02635	11.76890	
33	216.75649	17.00000	1.50839
34	161.01290	31.54706	
35	-206.90673	15.90000	1.50839
36	309.12541	56.09046	
37	-183.11187	18.00000	1.50839
38	-894.17440	6.28784	
39	-409.02115	23.00000	1.50839
40	-215.49999	1.14438	
41	3139.57999	23.00000	1.50839
42	-320.84882	2.92283	
43	445.47649	38.00000	1.50839
44	-348.37380	11.43498	
45	-229.01731	27.00000	1.50839
46	-352.88961	1.10071	
47	370.91242	25.00000	1.50839
48	-3446.41000	4.83032	
49	178.35450	32.00000	1.50839
50	471.60399	3.29194	
51	137.85195	39.90000	1.50839
52	331.09797	9.82671	
53	520.77561	23.00000	1.50839
54	80.26937	7.04896	
55	90.74309	71.00000	1.50839
56	1836.49001		

TABLE 2

Values corresponding to the Conditions in the First Embodiment	
(1)	$f_1/f_3 = 1.47$
(2)	$f_2/f_4 = 1.31$
(3)	$f_5/L = 0.0988$
(4)	$f_6/L = 0.154$
(5)	$f_n/f_2 = 0.589$
(6)	$I/L = 2.33$
(7)	$f_{21}/f_{23} = 0.990$
(8)	$f_{22}/f_{23} = 1.31$
(9)	$D/L = 0.0852$

TABLE 2-continued

Values corresponding to the Conditions in the First Embodiment	
5	(10) $f_1/L = -0.0638$
	(11) $f_2/L = -0.0834$
	(12) $(f_{5P} - f_{5n})/(f_{5P} + f_{5n}) = 0.207$
	(13) $(r_{1F} - r_{1R})/(r_{4F} + r_{4R}) = -0.660$
	(14) $(f_{5R} - f_{6F})/(f_{5R} + f_{6F}) = -0.0613$
	(15) $d_{56}/L = 0.00587$
10	(16) $d_6/r_{6F} = 1.10$
	(17) $(f_{5F} - f_{5R})/(f_{5F} + f_{5R}) = 0.733$
	(18) $1/(\phi_{21} \cdot L) = 0.895$
	(19) $f_{21}/L = 0.260$
	(20) $f_{2F}/f_{2R} = 0.604$

TABLE 3

Second Embodiment				
	$d_o = 103.54346$			
	$B = 1/5$			
	$NA = 0.55$			
	$Bf = 29.06029$			
	$L = 1200$			
r	d	n		
20				
25	1	-2191.4599	23.00000	1.50839
	2	-443.19378	18.81278	
	3	372.47246	20.00000	1.50839
	4	259.89086	7.92536	
	5	296.05557	26.00000	1.50839
30	6	-527.24081	1.04750	
	7	478.04893	27.00000	1.50839
	8	-948.34609	0.97572	
	9	210.20717	24.00000	1.50839
	10	107.85292	24.04713	
	11	241.18600	26.00000	1.50839
35	12	-438.52759	1.10686	
	13	-1434.49001	17.00000	1.50839
	14	132.17373	18.76700	
	15	-370.22109	12.90000	1.50839
	16	137.36441	26.88549	
	17	-131.18161	15.00000	1.50839
40	18	450.35044	53.03407	
	19	1459.21001	35.00000	1.50839
	20	-182.99101	14.91509	
	21	-132.88561	22.80000	1.50839
	22	-199.28914	2.79782	
	23	-5536.72998	27.00000	1.50839
	24	-310.674563	2.87255	
45	25	528.12523	28.00000	1.50839
	26	-1200.55000	2.49780	
	27	320.15215	30.00000	1.50839
	28	-2820.19000	1.64701	
	29	239.46093	31.00000	1.50839
	30	-2425.69000	5.60527	
50	31	$\infty$	21.00000	1.50839
	32	148.13116	9.76890	
	33	207.41773	17.00000	1.50839
	34	155.42831	31.54706	
	35	-218.29971	15.90000	1.50839
	36	304.21175	56.74759	
	37	-175.66635	18.00000	1.50839
55	38	-1130.86000	6.28784	
	39	-485.73656	23.00000	1.50839
	40	-216.43349	1.14438	
	41	2806.14999	23.00000	1.50839
	42	-316.00620	2.92283	
60	43	437.43410	38.00000	1.50839
	44	-355.32964	11.43498	
	45	-235.73758	27.00000	1.50839
	46	-360.50104	1.10071	
	47	410.57953	25.00000	1.50839
	48	-3698.22000	4.83032	
	49	178.15299	32.00000	1.50839
65	50	506.53177	3.29194	
	51	137.46544	39.90000	1.50839

TABLE 3-continued

Second Embodiment			
r	d	n	
$d_o = 103.54346$ $B = 1/5$ $NA = 0.55$ $Bf = 29.06029$ $L = 1200$			
52	328.51597	9.82671	
53	544.32105	23.00000	1.50839
54	81.70638	7.04896	
55	92.81520	34.00000	1.50839
56	511.57718	2.00000	
57	482.15006	35.00000	1.50839
58	1631.30000		

TABLE 4

Values corresponding to the Conditions in the Second Embodiment	
(1)	$f_1/f_3 = 1.50$
(2)	$f_2/f_4 = 1.39$
(3)	$f_5/L = 0.0971$
(4)	$f_6/L = 0.158$
(5)	$f_{1r}/f_{2r} = 0.568$
(6)	$I/L = 2.21$
(7)	$f_{21}/f_{23} = 1.01$
(8)	$f_{22}/f_{23} = 1.21$
(9)	$D/L = 0.0858$
(10)	$f_4/L = -0.0621$
(11)	$f_7/L = -0.0861$
(12)	$(r_{5P} - r_{5N})/(r_{5P} + r_{5N}) = 0.202$
(13)	$(r_{4F} - r_{4R})/(r_{4F} + r_{4R}) = -0.731$
(14)	$(r_{5R} - r_{6F})/(r_{5R} + r_{6F}) = -0.0637$
(15)	$d_{56}/L = 0.00587$
(16)	$d_6/r_{6F} = 1.08$
(17)	$(r_{5F} - r_{5R})/(r_{5F} + r_{5R}) = 0.739$
(18)	$1/(\Phi_{21} \cdot L) = 0.719$
(19)	$f_{21}/L = 0.239$
(20)	$f_{2F}/f_{2R} = 0.533$

TABLE 5

Third Embodiment			
r	d	n	
$d_o = 104.69561$ $B = 1/5$ $NA = 0.55$ $Bf = 29.13809$ $L = 1200$			
1	-1364.36000	23.00000	1.50839
2	-612.17411	20.81278	
3	699.63988	24.00000	1.50839
4	-301.81026	7.92536	
5	-248.00150	20.00000	1.50839
6	-614.52792	1.04750	
7	332.05244	27.00000	1.50839
8	-582.52759	0.97572	
9	232.12759	24.00000	1.50839
10	110.33434	27.04713	
11	230.79590	23.00000	1.50839
12	-359.85171	1.10686	
13	-1275.75999	17.00000	1.50839
14	127.98361	18.76700	
15	-569.83204	12.90000	1.50839
16	140.20359	26.88549	
17	-108.76770	15.00000	1.50839
18	593.61218	51.86789	

TABLE 5-continued

Third Embodiment			
r	d	n	
$d_o = 104.69561$ $B = 1/5$ $NA = 0.55$ $Bf = 29.13809$ $L = 1200$			
19	2324.85999	35.00000	1.50839
20	-163.53564	14.91509	
21	-121.26603	22.80000	1.50839
22	-192.12364	2.79782	
23	-4480.40997	27.00000	1.50839
24	-297.83388	2.87255	
25	445.50685	28.00000	1.50839
26	-877.28296	2.49780	
27	422.96766	27.00000	1.50839
28	-1570.03000	1.64701	
29	230.95785	31.00000	1.50839
30	3000.00000	8.60527	
31	1800.00000	21.00000	1.50839
32	138.38357	9.76890	
33	191.56081	17.00000	1.50839
34	157.70119	31.54706	
35	-217.22866	15.90000	1.50839
36	294.71194	56.69427	
37	-173.19975	18.00000	1.50839
38	-973.64548	6.28784	
39	-467.87775	23.00000	1.50839
40	-215.12034	1.14438	
41	2688.16000	23.00000	1.50839
42	-320.45010	2.92283	
43	441.22198	40.00000	1.50839
44	-347.09282	9.43495	
45	-239.46132	27.00000	1.50839
46	-386.98159	1.10071	
47	381.41679	28.00000	1.50839
48	-2576.25000	4.83032	
49	186.44642	29.00000	1.50839
50	570.80649	3.29194	
51	138.75412	39.90000	1.50839
52	316.26440	9.82671	
53	504.37073	23.00000	1.50839
54	80.26770	7.04896	
55	91.17058	71.00000	1.50839
56	1553.61000		

TABLE 6

Values corresponding to the Conditions in the Third Embodiment	
(1)	$f_1/f_3 = 1.46$
(2)	$f_2/f_4 = 1.27$
(3)	$f_5/L = 0.0977$
(4)	$f_6/L = 0.156$
(5)	$f_{1r}/f_{2r} = 0.591$
(6)	$I/L = 2.93$
(7)	$f_{21}/f_{23} = 0.816$
(8)	$f_{22}/f_{23} = 1.04$
(9)	$D/L = 0.0848$
(10)	$f_4/L = -0.0645$
(11)	$f_7/L = -0.0816$
(12)	$(r_{5P} - r_{5N})/(r_{5P} + r_{5N}) = 0.184$
(13)	$(r_{4F} - r_{4R})/(r_{4F} + r_{4R}) = -0.698$
(14)	$(r_{5R} - r_{6F})/(r_{5R} + r_{6F}) = -0.0636$
(15)	$d_{56}/L = 0.00587$
(16)	$d_6/r_{6F} = 1.10$
(17)	$(r_{5F} - r_{5R})/(r_{5F} + r_{5R}) = 0.725$
(18)	$1/(\Phi_{21} \cdot L) = 0.590$
(19)	$f_{21}/L = 0.234$
(20)	$f_{2F}/f_{2R} = 0.611$

TABLE 7

Fourth Embodiment			
	$d_o = 104.71662$		
	$B = 1/5$		
	$NA = 0.55$		
	$Bf = 28.76320$		
	$L = 1200$		
r	d	n	
1	955.26796	23.00000	1.50839
2	-675.53148	20.81278	
3	788.04209	24.00000	1.50839
4	-320.77870	7.92536	
5	-261.99847	20.00000	1.50839
6	-613.40707	1.04750	
7	343.77433	27.00000	1.50839
8	-614.74297	0.97572	
9	220.40014	24.00000	1.50839
10	111.87626	27.04713	
11	230.00000	23.00000	1.50839
12	-410.00000	1.10686	
13	-2449.05000	17.00000	1.50839
14	118.87129	18.76700	
15	-632.77988	12.90000	1.50839
16	143.15226	26.88549	
17	-108.88557	15.00000	1.50839
18	595.22400	52.22565	
19	1526.21000	35.00000	1.50839
20	-168.52598	14.91509	
21	-120.87196	22.80000	1.50839
22	-188.10351	2.79782	
23	-3191.22000	27.00000	1.50839
24	-296.62706	2.87255	
25	697.45117	28.00000	1.50839
26	-699.27158	2.49780	
27	358.82454	27.00000	1.50839
28	-2986.21000	1.64701	
29	223.50971	31.00000	1.50839
30	-1510.16000	8.60527	
31	-3596.81000	21.00000	1.50839
32	141.11696	9.76890	
33	194.35300	17.00000	1.50839
34	157.66411	31.54706	
35	-209.96142	15.90000	1.50839
36	307.10883	56.68624	
37	-175.13115	18.00000	1.50839
38	-1162.95000	6.28784	
39	-505.38166	23.00000	1.50839
40	-213.39177	1.14438	
41	3114.45000	23.00000	1.50839
42	-339.03822	2.92283	
43	460.54759	40.00000	1.50839
44	-326.27369	9.43498	
45	-231.89968	27.00000	1.50839
46	-372.57441	1.10071	
47	390.03678	28.00000	1.50839
48	-1994.66000	4.83032	
49	182.18377	29.00000	1.50839
50	525.45378	3.29194	
51	138.67730	39.90000	1.50839
52	312.43609	9.82671	
53	511.48346	23.00000	1.50839
54	81.45867	7.04896	
55	93.64185	34.00000	1.50839
56	934.34560	2.00000	
57	826.70065	35.00000	1.50839
58	1680.21000	(Bf)	

TABLE 8

Values corresponding to the Conditions in the Fourth Embodiment	
(1)	$f_1/f_3 = 1.55$
(2)	$f_2/f_4 = 1.39$
(3)	$f_5/L = 0.0975$
(4)	$f_6/L = 0.158$

TABLE 8-continued

Values corresponding to the Conditions in the Fourth Embodiment	
5	(5) $f_n/f_2 = 0.576$
	(6) $l/L = 3.05$
	(7) $f_{24}/f_{23} = 0.787$
	(8) $f_{22}/f_{23} = 0.974$
	(9) $D/L = 0.0851$
	(10) $f_4/L = -0.0606$
10	(11) $f_2/L = -0.0843$
	(12) $(r_{5P} - r_{5N})/(r_{5P} + r_{5N}) = 0.169$
	(13) $(r_{4F} - r_{4R})/(r_{4F} + r_{4R}) = -0.738$
	(14) $(r_{5R} - r_{6F})/(r_{5R} + r_{6F}) = -0.0695$
	(15) $d_{56}/L = 0.00587$
	(16) $d_6/r_{6F} = 1.07$
15	(17) $(r_{5F} - r_{5R})/(r_{5F} + r_{5R}) = 0.725$
	(18) $1/(\Phi_{21} \cdot L) = 0.672$
	(19) $f_{21}/L = 0.244$
	(20) $f_{2F}/f_{2R} = 0.642$

TABLE 9

Fifth Embodiment				
	$d_o = 105.99385$			
	$B = 1/5$			
	$NA = 0.55$			
	$Bf = 28.96856$			
	$L = 1200$			
r	d	n		
30	1	723.32335	28.00000	1.50839
	2	-571.27029	2.00000	
	3	-8470.94995	20.00000	1.50839
	4	324.13159	7.92536	
	5	360.44110	28.00000	1.50839
	6	-432.97069	1.04750	
35	7	397.04484	27.00000	1.50839
	8	-825.96923	0.97572	
	9	214.74004	31.00000	1.50839
	10	110.51892	24.04713	
	11	229.41181	26.00000	1.50839
	12	-396.52854	1.10686	
40	13	-1014.34000	17.00000	1.50839
	14	137.90605	18.76700	
	15	-418.55207	12.90000	1.50839
	16	138.89479	26.88549	
	17	-133.71351	15.00000	1.50839
	18	561.35918	52.53782	
	19	1381.31000	35.00000	1.50839
45	20	-188.69074	14.91509	
	21	-134.03345	22.80000	1.50839
	22	-198.69180	2.79782	
	23	-3029.37000	27.00000	1.50839
	24	-333.96362	2.87255	
	25	905.53484	28.00000	1.50839
50	26	-611.80005	2.49780	
	27	254.70879	30.00000	1.50839
	28	3936.53000	1.64701	
	29	239.51669	31.00000	1.50839
	30	-1238.94000	5.60527	
	31	-2379.42001	21.00000	1.50839
55	32	150.43068	9.76890	
	33	209.21387	17.00000	1.50839
	34	149.67785	31.54706	
	35	-199.55198	15.90000	1.50839
	36	341.76300	57.70880	
	37	-170.75300	18.00000	1.50839
	38	-3700.60999	6.28784	
60	39	-1025.75000	23.00000	1.50839
	40	-212.37919	1.14438	
	41	-3009.97000	23.00000	1.50839
	42	-312.33647	2.92283	
	43	401.05778	37.00000	1.50839
	44	-361.42967	12.43498	
65	45	-231.63315	27.00000	1.50839
	46	-319.48896	1.10071	

TABLE 9-continued

Fifth Embodiment			
	$d_o = 105.99385$		
	$B = 1/5$		
	$NA = 0.55$		
	$Bf = 28.96856$		
	$L = 1200$		
r	d	n	
47	355.64919	25.00000	1.50839
48	3678.53000	4.83032	
49	177.43364	32.00000	1.50839
50	553.83964	3.29194	
51	137.68248	39.90000	1.50839
52	330.86342	9.82671	
53	587.42747	23.00000	1.50839
54	81.23164	7.04896	
55	93.74477	71.00000	1.50839
56	1555.42999		

TABLE 10

Values corresponding to the Conditions in the Fifth Embodiment	
(1)	$f_1/f_3 = 1.58$
(2)	$f_2/f_4 = 1.63$
(3)	$f_5/L = 0.0923$
(4)	$f_6/L = 0.161$
(5)	$f_{17}/f_{23} = 0.554$
(6)	$I/L = 2.27$
(7)	$f_{24}/f_{23} = 1.04$
(8)	$f_{22}/f_{23} = 1.17$
(9)	$D/L = 0.0853$
(10)	$f_4/L = -0.0564$
(11)	$f_7/L = -0.0919$
(12)	$(r_{5P} - r_{5N})/(r_{5P} + r_{5N}) = 0.219$
(13)	$(r_{4F} - r_{4R})/(r_{4F} + r_{4R}) = -0.912$
(14)	$(r_{5R} - r_{6F})/(r_{5R} + r_{6F}) = -0.0715$
(15)	$d_{56}/L = 0.00587$
(16)	$d_6/r_{6F} = 1.07$
(17)	$(r_{5F} - r_{5R})/(r_{5F} + r_{5R}) = 0.757$
(18)	$1/(\phi_{21} \cdot L) = 0.650$
(19)	$f_{21}/L = 0.242$
(20)	$f_{2F}/f_{2R} = 0.541$

TABLE 11

Sixth Embodiment			
	$d_o = 105.91377$		
	$B = 1/5$		
	$NA = 0.55$		
	$Bf = 28.96856$		
	$L = 1200$		
r	d	n	
1	723.70616	28.00000	1.50839
2	-571.49375	1.98414	
3	-8427.42000	20.00000	1.50839
4	324.06902	8.06076	
5	360.49965	28.00000	1.50839
6	-432.97519	1.01484	
7	397.09644	27.00000	1.50839
8	-826.03537	0.88781	
9	214.74356	31.00000	1.50839
10	110.51666	24.03750	
11	229.41181	26.00000	1.50839
12	-396.60684	1.12963	
13	-1014.38000	17.00000	1.50839
14	137.92108	18.76756	
15	-418.59453	12.90000	1.50839
16	138.90550	26.88587	
17	-133.71351	15.00000	1.50839
18	561.20342	52.51989	

TABLE 11-continued

Sixth Embodiment			
	$d_o = 105.91377$		
	$B = 1/5$		
	$NA = 0.55$		
	$Bf = 28.96856$		
	$L = 1200$		
r	d	n	
19	1381.31000	35.00000	1.50839
20	-188.68876	14.85490	
21	-134.03581	22.80000	1.50839
22	-198.68592	2.89585	
23	-3029.37000	27.00000	1.50839
24	-333.96362	2.88769	
25	905.64444	28.00000	1.50839
26	-611.80428	2.47699	
27	254.70879	30.00000	1.50839
28	3936.53000	1.61920	
29	239.51669	31.00000	1.50839
30	-1238.94000	5.60156	
31	-2379.42000	21.00000	1.50839
32	150.42879	9.73510	
33	209.20275	16.99160	1.50839
34	149.68297	31.54706	
35	-199.55198	15.90229	1.50839
36	341.76300	57.70389	
37	-170.75300	18.00000	1.50839
38	-3700.61000	6.28293	
39	-1025.75000	23.00000	1.50839
40	-212.37919	1.14438	
41	-3009.97000	23.00000	1.50839
42	-312.33647	2.89661	
43	401.05778	37.00000	1.50839
44	-361.42967	12.47918	
45	-231.65257	27.00000	1.50839
46	-319.51171	1.23912	
47	355.64919	25.00000	1.50839
48	3678.53000	4.82925	
49	177.43453	32.00000	1.50839
50	553.98339	3.26768	
51	137.68248	39.90000	1.50839
52	330.86342	9.82671	
53	587.42747	23.00000	1.50839
54	81.23164	7.04896	
55	93.74477	71.00000	1.50839
56	1555.43000	(Bf)	

TABLE 12

Values corresponding to the Conditions the Sixth Embodiment	
(1)	$f_1/f_3 = 1.58$
(2)	$f_2/f_4 = 1.63$
(3)	$f_5/L = 0.0924$
(4)	$f_6/L = 0.161$
(5)	$f_7/f_9 = 0.554$
(6)	$I/L = 2.25$
(7)	$f_{24}/f_{23} = 1.04$
(8)	$f_{22}/f_{23} = 1.17$
(9)	$D/L = 0.0853$
(10)	$f_1/L = -0.0564$
(11)	$f_7/L = -0.0919$
(12)	$(r_{5P} - r_{5N})/(r_{5P} + r_{5N}) = 0.218$
(13)	$(r_{4F} - r_{4R})/(r_{4F} + r_{4R}) = -0.911$
(14)	$(r_{5R} - r_{6F})/(r_{5R} + r_{6F}) = -0.0715$
(15)	$d_{56}/L = 0.00587$
(16)	$d_6/r_{6F} = 1.07$
(17)	$(r_{5F} - r_{5R})/(r_{5F} + r_{5R}) = 0.757$
(18)	$1/(\phi_{21} \cdot L) = 0.650$
(19)	$f_{21}/L = 0.242$
(20)	$f_{2F}/f_{2R} = 0.541$

65 In the above-described first embodiment,  $1/|\phi L|=0.149$  for the object-side lens surface of the positive lens  $L_{61}$ , thus satisfying the condition (21). In the second embodiment,

$1/|\phi L|=0.152$  for the object-side lens surface of the positive lens  $L_{61}$  and  $1/|\phi L|=0.709$  for the object-side lens surface of the positive lens  $L_{62}$ , thus satisfying the condition (21). In the third embodiment,  $1/|\phi L|=0.149$  for the object-side lens surface of the positive lens  $L_{61}$  thus satisfying the condition (21). In the fourth embodiment,  $1/|\phi L|=0.153$  for the object-side lens surface of the positive lens  $L_{61}$  and  $1/|\phi L|=1.36$  for the object-side lens surface of the positive lens  $L_{62}$ , thus satisfying the condition (21). In the fifth embodiment,  $1/|\phi L|=0.153$  for the object-side lens surface of the positive lens  $L_{61}$ , thus satisfying the condition (21). In the sixth embodiment,  $1/|\phi L|=0.154$  for the object-side lens surface of the positive lens  $L_{61}$  thus satisfying the condition (21). Therefore, the sixth lens group  $G_6$  in each embodiment is composed of three or less lenses having the lens surface(s) satisfying the condition (21).

From the above values of specifications for the respective embodiments, it is understood that the telecentricity is achieved on the object side (on the reticle side) and on the image side (on the wafer side) while maintaining a relatively wide exposure area and a large numerical aperture in each embodiment.

FIG. 9, FIG. 10, FIG. 11, FIG. 12, FIG. 13, and FIG. 14 show aberration diagrams of various aberrations in the first to the sixth embodiments according to the present invention.

Here, in each aberration diagram, NA represents the numerical aperture of the projection optical system and Y the image height. In each aberration diagram of astigmatism, the dotted line represents a meridional image surface (meridional image surface) and the solid line a sagittal image surface (sagittal image surface).

From the comparison of the aberration diagrams, it is seen that the various aberrations are corrected in a good balance in each embodiment, particularly the distortion is corrected very well over the entire image up to a nearly zero state and the high-resolving-power projection optical system is achieved with a large numerical aperture.

Although the above embodiments showed the examples where the excimer laser for supplying the light of 248.4 nm was used as a light source, it is needless to mention that, without a need to be limited to the examples, the present invention can be applied to systems using extreme ultraviolet light sources such as an excimer laser for supplying the light of 193 nm, mercury arc lamps for supplying the light of the g-line (436 nm) or the i-line (365 nm), or light sources for supplying the light in the ultraviolet region other than those.

In the embodiments neither of the lenses constituting the projection optical system is a compound lens, and either of them is made of a single optical material, i.e., of quartz ( $\text{SiO}_2$ ). Here, a cost reduction can be achieved because a single optical material forms each lens in the above embodiments. However, if the exposure light has a certain half width, a chromatic aberration can be corrected by a combination of quartz ( $\text{SiO}_2$ ) and fluorite ( $\text{CaF}_2$ ) or by a combination of other optical materials. Further, if the exposure light source supplies the exposure light in a wide band, the chromatic aberration can be corrected by a combination of plural types of optical materials.

As described above, the exposure apparatus relating to the present invention has achieved the projection optical systems which are bitelecentric optical systems with a relatively wide exposure area kept and which are high-resolving-power projection optical systems in which the various aberrations are corrected in a good balance and which have a large numerical aperture. Particularly, the distortion is

corrected very well in the projection optical systems of the present invention. Accordingly, the present invention can enjoy an extreme reduction of image stress, because the distortion is also corrected very well in addition to the achievement of the bitelecentricity.

From the invention thus described, it will be obvious that the invention may be varied in many ways. Such variations are not to be regarded as a departure from the spirit and scope of the invention, and all such modifications as would be obvious to one skilled in the art are intended to be included within the scope of the following claims.

The basic Japanese Application No. 6-311050 (311050/1994) filed on Dec. 14, 1994 is hereby incorporated by reference.

What is claimed is:

1. A projection optical system located between a first object and a second object, for projecting an image of the first object onto the second object, said projection optical system having:

a first lens group with positive refracting power, said first lens group being placed between the first and second objects;

a second lens group with negative refracting power, said second lens group being placed between said first lens group and the second object;

a third lens group with positive refracting power, said third lens group being placed between said second lens group and the second object;

a fourth lens group with negative refracting power, said fourth lens group being placed between said third lens group and the second object;

a fifth lens group with positive refracting power, said fifth lens group being placed between said fourth lens group and the second object; and

a sixth lens group with positive refracting power, said sixth lens group being placed between said fifth lens group and the second object,

wherein said first lens group includes at least two positive lenses, said third lens group includes at least three positive lenses, said fourth lens group includes at least three negative lenses, said fifth lens group includes at least five positive lenses and at least one negative lens, and said sixth lens group includes at least one positive lens,

wherein said second lens group comprises a front lens placed as closest to the first object and having negative refracting power with a concave surface to the second object, a rear lens placed as closest to the second object and having negative refracting power with a concave surface to the first object, and an intermediate lens group placed between said front and rear lenses in said second lens group, and

wherein said intermediate lens group has a first lens with positive refracting power, a second lens with negative refracting power, a third lens with negative refracting power, and a fourth lens with negative refracting power in the named order from the first object toward the second object.

2. A projection optical system according to claim 1, wherein the first lens with positive refracting power in said intermediate lens group in said second lens group has a lens shape with a convex surface to the second object.

3. A projection optical system according to claim 2, wherein said fourth lens group comprises a front lens placed as closest to the first object and having negative refracting

power with a concave surface to the second object, a rear lens placed as closest to the second object and having negative refracting power with a concave surface to the first object, and at least one negative lens placed between said front lens in said fourth lens group and said rear lens in said fourth lens group.

4. A projection optical system according to claim 3, wherein said fifth lens group comprises a negative meniscus lens, and a positive lens placed as adjacent to a concave surface of said negative meniscus lens and having a convex surface opposed to the concave surface of said negative meniscus lens.

5. A projection optical system according to claim 4, wherein said negative meniscus lens and said positive lens adjacent to the concave surface of said negative meniscus lens are placed between positive lenses in said fifth lens group.

6. A projection optical system according to claim 5, wherein said fifth lens group comprises a negative lens placed as closest to the second object and having a concave surface opposed to the second object.

7. A method for fabricating at least semiconductor devices or liquid crystal display devices by using a projection optical system according to claim 5, comprising the steps of:

illuminating a mask prepared as said first object with light of a predetermined wavelength, said mask being formed *with* a predetermined pattern thereon; and

projecting an image of the pattern on said mask onto a photosensitive substrate prepared as said second object through said projection optical system, thereby performing an exposure process.

8. A projection optical system according to claim 6, wherein said sixth lens group comprises a lens placed as closest to the first object and having a convex surface opposed to the first object.

9. A method for fabricating at least semiconductor devices or liquid crystal display devices by using a projection optical system according to claim 8, comprising the steps of:

illuminating a mask prepared as said first object with light of a predetermined wavelength, said mask being formed *with* a predetermined pattern thereon; and

projecting an image of the pattern on said mask onto a photosensitive substrate prepared as said second object through said projection optical system, thereby performing an exposure process.

10. A projection optical system according to claim 1, wherein said fourth lens group comprises a front lens placed as closest to the first object and having negative refracting power with a concave surface to the second object, a rear lens placed as closest to the second object and having a negative refracting power with a concave surface to the first object, and at least one negative lens placed between said front lens in said fourth lens group and said rear lens in said fourth lens group.

11. A projection optical system according to claim 1, wherein said fifth lens group comprises a negative meniscus lens, and a positive lens placed as adjacent to a concave surface of said negative meniscus lens and having a convex surface opposed to the concave surface of said negative meniscus lens.

12. A method for fabricating at least semiconductor devices or liquid crystal display devices by using a projection optical system according to claim 1, comprising the steps of:

illuminating a mask prepared as said first object with light of a predetermined wavelength, said mask being formed *with* a predetermined pattern thereon; and

projecting an image of the pattern on said mask onto a photosensitive substrate prepared as said second object through said projection optical system, thereby performing an exposure process.

13. A projection optical system located between a first object and a second object, said projection optical system having a first lens group with positive refracting power, a second lens group with negative refracting power, a third lens group with positive refracting power, a fourth lens group with negative refracting power, a fifth lens group with positive refracting power, and a sixth lens group with positive refracting power in the named order from the first object toward the second object,

wherein said first lens group includes at least two positive lenses, said third lens group includes at least three positive lenses, said fourth lens group includes at least three negative lenses, said fifth lens group includes at least five positive lenses and at least one negative lens, and said sixth lens group includes at least one positive lens,

wherein said second lens group comprises a front lens placed as closest to the first object and having negative refracting power with a concave surface to the second object, a rear lens placed as closest to the second object and having negative refracting power with a concave surface to the first object, and an intermediate lens group placed between said front and rear lenses in said second lens group,

wherein said intermediate lens group has a first lens with positive refracting power, a second lens with negative refracting power, a third lens with negative refracting power, and a fourth lens with negative refracting power in the named order from the first object toward the second object, and

wherein the following conditions are satisfied when a focal length of said first lens group is  $f_1$ , a focal length of said second lens group is  $f_2$ , a focal length of said third lens group is  $f_3$ , a focal length of said fourth lens group is  $f_4$ , a focal length of said fifth lens group is  $f_5$ , a focal length of said sixth lens group is  $f_6$ , an overall focal length of said second lens to said fourth lens in said intermediate lens group in said second lens group is  $f_n$ , and a distance from the first object to the second object is L:

$$0.1 < f_1/f_3 < 1.7$$

$$0.1 < f_2/f_4 < 1.4$$

$$0.01 < f_5/L < 0.9$$

$$0.02 < f_6/L < 1.6$$

$$0.01 < f_n/f_2 < 2.0.$$

14. A projection optical system according to claim 13, wherein the following condition is satisfied when an axial distance from the first object to a first-object-side focal point of the whole of said projection optical system is I and the distance from the first object to the second object is L:

$$1.0 < I/L.$$

15. A projection optical system according to claim 14, [therein] wherein the following condition is satisfied when a focal length of said third lens with negative refracting power in said second lens group is  $f_{23}$  and a focal length of said

fourth lens with negative refracting power in said intermediate lens group in said second lens group is  $f_{24}$ :

$$0.07 < f_{24}/f_{23} < 7.$$

16. A projection optical system according to claim 15, wherein the following condition is satisfied when a focal length of said second lens with negative refracting power in said intermediate lens group in said second lens group is  $f_{22}$  and a focal length of said third lens with negative refracting power in said intermediate lens group in said second lens group is  $f_{23}$ :

$$0.01 < f_{22}/f_{23} < 10.$$

17. A projection optical system according to claim 16, wherein the following condition is satisfied when a focal length of said first lens with positive refracting power in said intermediate lens group in said second lens group is  $f_{21}$  and the distance from the first object to the second object is L:

$$0.230 < f_{21}/L < 0.40.$$

18. A method for fabricating at least semiconductor devices or liquid crystal display devices by using a projection optical system according to claim 16, comprising the steps of:

illuminating a mask prepared as said first object with light of a predetermined wavelength, said mask being formed with a predetermined pattern thereon; and

projecting an image of the pattern on said mask onto a photosensitive substrate prepared as said second object through said projection optical system, thereby performing an exposure process.

19. A projection optical system according to claim 13, wherein said intermediate lens group in said second lens group has negative refracting power.

20. A projection optical system according to claim 13, wherein the following condition is satisfied when the focal length of said second lens group is  $f_2$  and the distance from the first object to the second object is L:

$$-0.8 < f_2/L < -0.050.$$

21. A projection optical system according to claim 13, wherein the following condition is satisfied when a focal length of said front lens placed as closest to the first object in said second lens group and having negative refracting power with a concave surface to the second object is  $f_{2F}$  and a focal length of said rear lens placed as closest to the second object in said second lens group and having negative refracting power with a concave surface to the first object is  $f_{2R}$ :

$$0 \leq f_{2F}/f_{2R} < 18.$$

22. A projection optical system according to claim 13, wherein the following condition is satisfied when a focal length of said third lens with negative refracting power in said second lens group is  $f_{23}$  and a focal length of said fourth lens with negative refracting power in said intermediate lens group in said second lens group is  $f_{24}$ :

$$0.07 < f_{24}/f_{23} < 7.$$

23. A projection optical system according to claim 13, wherein the following condition is satisfied when a focal length of said second lens with negative refracting power in said intermediate lens group in said second lens group is  $f_{22}$  and a focal length of said third lens with negative refracting

power in said intermediate lens group in said second lens group is  $f_{23}$ :

$$0.1 < f_{22}/f_{23} < 10.$$

24. A projection optical system according to claim 13, wherein the following condition is satisfied when an axial distance from a second-object-side lens surface of said fourth lens with negative refracting power in said intermediate lens group in said second lens group to a first-object-side lens surface of said rear lens in said second lens group is D and the distance from the first object to the second object is L:

$$0.05 < D/L < 0.4.$$

25. A projection optical system according to claim 13, wherein said first lens with positive refracting power in said intermediate lens group in said second lens group has a lens shape with a convex surface to the second object, and

wherein the following condition is satisfied when the refracting power of a second-object-side lens surface of said first lens with positive refracting power in said intermediate lens group in said second lens group is  $\Phi_{21}$  and the distance from the first object to the second object is L:

$$0.54 < 1/(\Phi_{21} \cdot L) < 10.$$

26. A projection optical system according to claim 13, wherein the following condition is satisfied when a focal length of said first lens with positive refracting power in said intermediate lens group in said second lens group is  $f_{21}$  and the distance from the first object to the second object is L:

$$0.230 < f_{21}/L < 0.40.$$

27. A projection optical system according to claim 13, wherein the following condition is satisfied when the focal length of said fourth lens group is  $f_4$  and the distance from the first object to the second object is L:

$$-0.098 < f_4/L < -0.005.$$

28. A projection optical system according to claim 13, wherein said fourth lens group comprises a front lens placed as closest to the first object and having negative refracting power with a concave surface to the second object, a rear lens placed as closest to the second object and having negative refracting power with a concave surface to the first object, and at least one negative lens placed between said front lens in said fourth lens group and said rear lens in said fourth lens group, and

wherein the following condition is satisfied when a radius of curvature on the first object side in said rear lens places as closest to the second object in said fourth lens group is  $r_{4F}$  and a radius of curvature on the second object side in said rear lens placed as closest to the second object in said fourth lens group is  $r_{4R}$ :

$$-1.00 \leq (r_{4F} - r_{4R}) / (r_{4F} + r_{4R}) < 0.$$

29. A projection optical system according to claim 13, wherein said fifth lens group comprises a negative meniscus lens, and a positive lens placed as adjacent to a concave surface of said negative meniscus lens and having a convex surface opposed to the concave surface of said negative meniscus lens, and

wherein the following condition is satisfied when a radius of curvature of the concave surface of said negative

31

meniscus lens in said fifth lens group is  $r_{5n}$  and a radius of curvature of the convex surface opposed to the concave surface of said negative meniscus lens in said positive lens placed adjacent to the concave surface of said negative meniscus lens in said fifth lens group is  $r_{5p}$ :

$$0 < (r_{5p} - r_{5n}) / (r_{5p} + r_{5n}) < 1.$$

30. A projection optical system according to claim 29, wherein said negative meniscus lens and said positive lens adjacent to the concave surface of said negative meniscus lens are placed between positive lenses in said fifth lens group.

31. A projection optical system according to claim 13, wherein said fifth lens group comprises a negative lens placed as closest to the second object and having a concave surface opposed to the second object, and

wherein the following condition is satisfied when a radius of curvature on the first object side in said negative lens closest to the second object in said fifth lens group is  $r_{5F}$  and a radius of curvature on the second object side in said negative lens closest to the second object in said fifth lens group is  $r_{5R}$ :

$$0.30 < (r_{5F} - r_{5R}) / (r_{5F} + r_{5R}) < 1.28.$$

32. A projection optical system according to claim 13, wherein said fifth lens group comprises a negative lens placed as closest to the second object and having a concave surface opposed to the second object and said sixth lens group comprises a lens placed as closest to the first object and having a convex surface opposed to the first object, and

wherein the following condition is satisfied when a radius of curvature on the second object side, of said negative lens placed as closest to the second object in said fifth lens group is  $r_{5R}$  and a radius of curvature on the first object side, of said lens placed as closest to the first object in said sixth lens group is  $r_{6F}$ :

$$-0.90 < (r_{5R} - r_{6F}) / (r_{5R} + r_{6F}) < -0.001.$$

33. A projection optical system according to claim 13, wherein the following condition is satisfied when a lens group separation between said fifth lens group and said sixth lens group is  $d_{56}$  and the distance from the first object to the second object is L:

$$d_{56} / L < 0.017.$$

34. A projection optical system according to claim 13, wherein the following condition is satisfied when a radius of curvature of a lens surface closest to the first object in said sixth lens group is  $r_{6F}$  and an axial distance from the lens surface closest to the first object in said sixth lens group to the second object is  $d_6$ :

$$0.50 < d_6 / r_{6F} < 1.50.$$

35. A projection optical system according to claim 13, wherein said sixth lens group comprises three or less lenses having at least one surface satisfying the following condition:

$$1 / |\Phi L| < 20,$$

where  $\Phi$ : refracting power of the lens surface;

L: object-image distance from the first object to the second object.

32

36. A projection optical system according to claim 13, wherein a magnification of said projection optical system is 5:1.

37. A method for fabricating at least semiconductor devices or liquid crystal display devices by using a projection optical system according to claim 13, comprising the steps of:

illuminating a mask prepared as said first object with light of a predetermined wavelength, said mask being formed with a predetermined pattern thereon; and

projecting an image of the pattern on said mask onto a photosensitive substrate prepared as said second object through said projection optical system, thereby performing an exposure process.

38. A projection optical system according to claim 13, wherein said fifth lens group comprises a negative lens placed as closest to the second object and having a concave surface opposed to the second object.

39. A projection optical system according to claim 38, wherein the following condition is satisfied when a lens group separation between said fifth lens group and said sixth lens group is  $d_{56}$  and the distance from the first object to the second object is L:

$$d_{56} / L < 0.017.$$

40. A projection optical system according to claim 38, wherein the following condition is satisfied when a radius of curvature of a lens surface closest to the first object in said sixth lens group is  $r_{6F}$  and an axial distance from the lens surface closest to the first object in said sixth lens group to the second object is  $d_6$ :

$$0.50 < d_6 / r_{6F} < 1.50.$$

41. A projection optical system according to claim 38, wherein said sixth lens group comprises three or less lenses having at least one surface satisfying the following condition:

$$1 / |\Phi L| < 20.$$

where  $\Phi$ : refracting power of the lens surface;

L:

object-image distance from the first object to the second object.

42. An exposure apparatus comprising:

a stage allowing a photosensitive substrate to be held on a main surface thereof;

an illumination optical system for emitting exposure light of a predetermined wavelength and transferring a predetermined pattern on a mask onto the substrate; and

a projecting optical system for projecting an image of the mask, on the substrate surface, said projecting optical system having:

a first lens group with positive refracting power, said first lens group being placed between the mask and the main surface of said stage;

a second lens group with negative refracting power, said second lens group being placed between said first lens group and the main surface of said stage;

a third lens group with positive refracting power, said third lens groups being placed between said second lens group and the main surface of said stage;

a fourth lens group with negative refracting power, said fourth lens group being placed between said third lens group and the main surface of said stage;

a fifth lens group with positive refracting power, said fifth lens group being placed between said fourth lens group and the main surface of said stage; and a sixth lens group, said sixth lens group being placed between said fifth lens group and the main surface of said stage, 5  
 wherein said first lens group includes at least two positive lenses, said third lens group includes at least three positive lenses, said fourth lens group includes at least three negative lenses, said fifth lens group includes at least five positive lenses and at least one negative lens, and said sixth lens group includes at least one positive lens, 10  
 wherein said second lens group comprises a front lens placed as closest to the first object and having a negative refracting power with a concave surface to the second object, a rear lens as closest to the second object and having negative refracting power with a concave surface to the first object, and an intermediate lens group placed between said front and rear lenses in said second lens group, and 15  
 wherein said intermediate lens group has a first lens with positive refracting power, a second lens with negative refracting power, a third lens with negative refracting power, and a fourth lens with negative refracting power in the named order from the first object toward the second object. 20

43. An exposure apparatus according to claim 42,

wherein the following conditions are satisfied when a focal length of said first lens group is  $f_1$ , a focal length of said second lens group is  $f_2$ , a focal length of said third lens group is  $f_3$ , a focal length of said fourth lens group is  $f_4$ , a focal length of said fifth lens group is  $f_5$ , a focal length of said sixth lens group is  $f_6$ , an overall focal length of said second lens to said fourth lens in said intermediate lens group in said second lens group is  $f_n$ , and a distance from the first object to the second object is L: 30

$0.1 < f_1/f_3 < 17$

$0.1 < f_1/f_4 < 14$

$0.01 < f_3/L < 0.9$

$0.02 < f_6/L < 1.6$

$0.01 < f_n/f_2 < 2.0$ . 35

44. A projection optical system located between a first object and a second object, for projecting an image of the first object onto the second object, said projection optical system having: 50

- a first lens group with positive refracting power, said first lens group being placed between the first and second objects; 55
- a second lens group with negative refracting power, said second lens group being placed between said first lens group and the second object;
- a third lens group with positive power, said third lens group being placed between said second lens group and the second object; 60
- a fourth lens group with negative refracting power, said fourth lens group being placed between said third lens group and the second object;
- a fifth lens group with positive refracting power, said fifth lens group being placed between said fourth lens group and the second object; and 65

a sixth lens group with positive refracting power, said sixth lens group being placed between said fifth lens group and the second object,

wherein said first lens group includes at least two positive lenses, said third lens group includes at least three positive lenses, said fourth lens group includes at least three negative lenses, said fifth lens group includes at least five positive lenses and at least one negative lens, and said sixth lens group includes at least one positive lens, and

wherein said fifth lens group comprises a negative meniscus lens, and a positive lens placed as adjacent to a concave surface of said negative meniscus lens and having a convex surface opposed to the concave surface of said negative meniscus lens.

45. A projection optical system according to claim 44, wherein said negative meniscus lens and said positive lens adjacent to the concave surface of said negative meniscus lens are placed between positive lenses in said fifth lens group.

46. A projection optical system according to claim 45, wherein the following condition is satisfied when an axial distance from the first object to a first-object-side focal point of the whole of said projection optical system is I and the distance from the first object to the second object is L:

$1.0 < I/L$ .

47. A projection optical system according to claim 46, wherein said fourth lens group comprises a front lens placed as closest to the first object and having negative refracting power with a concave surface to the second object, a rear lens placed as closest to the second object and having negative refracting power with a concave surface to the first object, and at least one negative lens placed between said front lens in said fourth lens group and said rear lens in said fourth lens group. 35

48. A projection optical system according to claim 47, wherein said second lens group comprises a front lens placed as closest to the first object and having negative refracting power with a concave surface to the second object, a rear lens placed as closest to the second object and having negative refracting power with a concave surface to the second object and having negative refracting power with a concave surface to the first object, and an intermediate lens group placed between said front and rear lenses in said second lens group, 40

wherein said intermediate lens group has a first lens with positive refracting power, a second lens with negative refracting power, a third lens with negative refracting power, and a fourth lens with negative refracting power in the named order from the first object toward the second object, and 45

wherein the following conditions are satisfied when a focal length of said first lens group is  $f_1$ , a focal length of said second lens group is  $f_2$ , a focal length of said third lens group is  $f_3$ , a focal length of said fourth lens group is  $f_4$ , a focal length of said fifth lens group is  $f_5$ , a focal length of said sixth lens group is  $f_6$ , an overall focal length of said second lens to said fourth lens in said intermediate lens group in said second lens group is  $f_n$ , and a distance from the first object to the second object is L: 50

$0.1 < f_1/f_3 < 17$

$0.1 < f_1/f_4 < 14$

$$0.01 < f_3/L < 0.9$$

$$0.02 < f_6/L < 1.6$$

$$0.01 < f_n/f_2 < 2.0.$$

49. A projection optical system according to claim 48, wherein the following condition is satisfied when a focal length of said third lens with negative refracting power in said second lens group is  $f_{23}$  and a focal length of said fourth lens with negative refracting power in said intermediate lens group in said second lens group is  $f_{24}$ :

$$0.07 < f_{24}/f_{23} < 7.$$

50. A projection optical system according to claim 49, wherein the following condition is satisfied when a focal length of said second lens with negative refracting power in said intermediate lens group in said second lens group is  $f_{22}$  and a focal length of said third lens with negative refracting power in said intermediate lens group in said second lens group is  $f_{23}$ :

$$0.01 < f_{22}/f_{23} < 10.$$

51. A projection optical system according to claim 49, wherein the following condition is satisfied when a focal length of said second lens with negative refracting power in said intermediate lens group in said second lens group is  $f_{22}$  and a focal length of said third lens with negative refracting power in said intermediate lens group in said second lens group is  $f_{23}$ :

$$0.01 < f_{22}/f_{23} < 10.$$

52. A projection optical system according to claim 50, wherein the following condition is satisfied when a focal length of said first lens with positive refracting power in said intermediate lens group in second lens group is  $f_{21}$  and the distance from the first object to the second object is L:

$$0.230 < f_{21}/L < 0.40.$$

53. A projection optical system according to claim 50, wherein the following condition is satisfied when a focal length of said first lens with positive refracting power in said intermediate lens group in said second lens group is  $f_{21}$  and the distance from the first object to the second object is L:

$$0.230 < f_{21}/L < 0.40.$$

54. A method for fabricating at least semiconductor devices or liquid crystal display devices by using a projection optical system according to claim 50, comprising the steps of:

- illuminating a mask prepared as said first object with light of a predetermined wavelength, said mask being formed *with* a predetermined pattern thereon; and
- projecting an image of the pattern on said mask onto a photosensitive substrate prepared as said second object through said projection optical system, thereby performing an exposure process.

55. A projection optical system according to claim 46, wherein said second lens group comprises a front lens placed as closest to the first object and having negative refracting power with a concave surface to the second object, a rear lens placed as closest to the second object and having negative refracting power with a concave surface to the first object, and an intermediate lens group placed between said front and rear lenses in said second lens group,

wherein said intermediate lens group has a first lens with positive refracting power, a second lens with negative refracting power, a third lens with negative refracting power, and a fourth lens with negative refracting power in the named order from the first object toward the second object, and

wherein the following conditions are satisfied when a focal length of said first lens group is  $f_1$ , a focal length of said second lens group is  $f_2$ , a focal length of said third lens group is  $f_3$ , a focal length of said fourth lens group is  $f_4$ , a focal length of said fifth lens group is  $f_5$ , a focal length of said sixth lens group is  $f_6$ , an overall focal length of said second lens to said fourth lens in said intermediate lens group in said second lens group is  $f_n$ , and a distance from the first object to the second object is L:

$$0.1 < f_1/f_3 < 17$$

$$0.1 < f_2/f_4 < 14$$

$$0.01 < f_5/L < 0.9$$

$$0.02 < f_6/L < 1.6$$

$$0.01 < f_n/f_2 < 2.0.$$

56. A projection optical system according to claim 55, wherein the following condition is satisfied when a focal length of said third lens with negative refracting power in said second lens group is  $f_{23}$  and a focal length of said fourth lens with negative refracting power in said intermediate lens group in said second lens group is  $f_{24}$ :

$$0.07 < f_{24}/f_{23} < 7.$$

57. A projection optical system according to claim 47, wherein said fifth lens group comprises a negative lens placed as closest to the second object and having a concave surface opposed to the second object.

58. A projection optical system according to claim 57, wherein the following condition is satisfied when a radius of curvature of a lens surface closest to the first object in said sixth lens group is  $r_{6F}$  and an axial distance from the lens surface closest to the first object in said sixth lens group to the second object is  $d_6$ :

$$0.50 < d_6/r_{6F} < 1.50.$$

59. A method for fabricating at least semiconductor devices or liquid crystal display devices by using a projection optical system according to claim 58, comprising the steps of:

- illuminating a mask prepared as said first object with light of a predetermined wavelength, said mask being formed *with* a predetermined pattern thereon; and
- projecting an image of the pattern on said mask onto a photosensitive substrate prepared as said second object through said projection optical system, thereby performing an exposure process.

60. A projection optical system according to claim 58, wherein said second lens group comprises a front lens placed as closest to the first object and having negative refracting power with a concave surface to the second object, a rear lens placed as closest to the second object and having negative refracting power with a concave surface to the first object, and an intermediate lens group placed between said front and rear lenses in said second lens group,

37

wherein said intermediate lens group has a first lens with positive refracting power, a second lens with negative refracting power, a third lens with negative refracting power, and a fourth lens with negative refracting power in the named order from the first object toward the second object, and

wherein the following conditions are satisfied when a focal length of said first lens group is  $f_1$ , a focal length of said second lens group is  $f_2$ , a focal length of said third lens group is  $f_3$ , a focal length of said fourth lens group is  $f_4$ , a focal length of said fifth lens group is  $f_5$ , a focal length of said sixth lens group is  $f_6$ , an overall focal length of said second lens to said fourth lens in said intermediate lens group in said second lens group is  $f_m$ , and a distance from the first object to the second object is L:

$$0.1 < f_1/f_3 < 17$$

$$0.1 < f_2/f_4 < 14$$

$$0.01 < f_3/L < 0.9$$

$$0.02 < f_6/L < 1.6$$

$$0.01 < f_m/f_2 < 2.0.$$

61. A projection optical system according to claim 60, wherein the following condition is satisfied when a focal length of said third lens with negative refracting power in said second lens group is  $f_{23}$  and a focal length of said fourth lens with negative refracting power in said intermediate lens group in said second lens group is  $f_{24}$ :

$$0.07 < f_{24}/f_{23} < 7.$$

62. A projection optical system according to claim 61, wherein the following condition is satisfied when a focal length of said second lens with negative refracting power in said intermediate lens group in said second lens group is  $f_{22}$  and a focal length of said third lens with negative refracting power in said intermediate lens group in said second lens group is  $f_{23}$ :

$$0.01 < f_{22}/f_{23} < 10.$$

63. A projection optical system according to claim 62, wherein the following condition is satisfied when a focal length of said first lens with positive refracting power in said intermediate lens group in said second lens group is  $f_{21}$  and the distance from the first object to the second object is L:

$$0.230 < f_{21}/L < 0.40.$$

64. A method for fabricating at least semiconductor devices or liquid crystal display devices by using a projection optical system according to claim 44, comprising the steps of:

illuminating a mask prepared as said first object with light of a predetermined wavelength, said mask being formed with a predetermined pattern thereon; and

projecting an image of the pattern on said mask onto a photosensitive substrate prepared as said second object through said projection optical system, thereby performing an exposure process.

65. A projection optical system located between a first object and a second object, for projecting an image of the first object onto the second object, said projection optical system having:

a first lens group with positive refracting power, said first lens group being placed between the first and second objects;

38

a second lens group with negative refracting power, said second lens group being placed between said first lens group and the second object;

a third lens group with positive refracting power, said third lens group being placed between said second lens group and the second object;

a fourth lens group with negative refracting power, said fourth lens group being placed between said third lens group and the second object;

a fifth lens group with positive refracting power, said fifth lens group being placed between said fourth lens group and the second object; and

a sixth lens group with positive refracting power, said sixth lens group being placed between said fifth lens group and the second object,

wherein said first lens group includes at least two positive lenses, said third lens group includes at least three positive lenses, said fourth lens group includes at least three negative lenses, said fifth lens group includes at least five positive lenses and at least one negative lens, and said sixth lens group includes at least one positive lens,

wherein said fourth lens group comprises a front lens placed as closest to the first object and having negative refracting power with a concave surface to the second object, a rear lens placed as closest to the second object and having negative refracting power with a concave surface to the first object, and at least one negative lens placed between said front lens in said fourth lens group and said rear lens in said fourth lens group, and

wherein the following condition is satisfied when a radius of curvature on the first object side in said rear lens placed as closest to the second object in said fourth lens group is  $r_{4F}$  and a radius of curvature on the second object side in said rear lens placed as closest to the second object in said fourth lens group is  $r_{4R}$ :

$$-1.00 \leq (r_{4F} - r_{4R}) / (r_{4F} + r_{4R}) < 0.$$

66. A method for fabricating at least semiconductor devices or liquid crystal display devices by using a projection optical system according to claim 65, comprising the steps of:

illuminating a mask prepared as said first object with light of a predetermined wavelength, said mask being formed with a predetermined pattern thereon; and

projecting an image of the pattern on said mask onto a photosensitive substrate prepared as said second object through said projection optical system, thereby performing an exposure process.

67. A projection optical system according to claim 65, wherein said fifth lens group comprises a negative meniscus lens, and a positive lens placed as adjacent to a concave surface of said negative meniscus lens and having a convex surface opposed to the concave surface of said negative meniscus lens, and

wherein the following condition is satisfied when a radius of curvature of the concave surface of said negative meniscus lens in said fifth lens group is  $r_{5n}$  and a radius of curvature of the convex surface opposed to the concave surface of said negative meniscus lens in said positive lens placed adjacent to the concave surface of said negative meniscus lens in said fifth lens group is  $r_{5p}$ :

$$0 < (r_{5p} - r_{5n}) / (r_{5p} + r_{5n}) < 1.$$

68. A projection optical system according to claim 67, wherein said negative meniscus lens and said positive lens adjacent to the concave surface of said negative meniscus lens are placed between positive lenses in said fifth lens group.

69. A method for fabricating at least semiconductor devices or liquid crystal display devices by using a projection optical system according to claim 68, comprising the steps of:

- illuminating a mask prepared as said first object with light of a predetermined wavelength, said mask being formed *with* a predetermined pattern thereon; and
- projecting an image of the pattern on said mask onto a photosensitive substrate prepared as said second object through said projection optical system, thereby performing an exposure process.

70. An exposure apparatus comprising:

a stage allowing a photosensitive substrate to be held on a main surface thereof;

an illumination optical system for emitting exposure light of a predetermined wavelength and transferring a predetermined pattern on a mask onto said substrate; and

a projecting optical system for projecting an image of the pattern on said mask onto said substrate, said projecting optical system being provided between said mask and said substrate and having:

- a first lens group with positive refracting power, said first lens group being placed between said mask and said substrate;
- a second lens group with negative refracting power, said second lens group being placed between said first lens group and said substrate;
- a third lens group with positive refracting power, said third lens group being placed between said second lens group and said substrate;
- a fourth lens group with negative refracting power, said fourth lens group being placed between said third lens group and said substrate;
- a fifth lens group with positive refracting power, said fifth lens group being placed between said fourth lens group and said substrate; and
- a sixth lens group with positive refracting power, said sixth lens group being placed between said fifth lens group and said substrate,

wherein said first lens group includes at least two positive lenses, said third lens group includes at least three positive lenses, said fourth lens group includes at least three negative lenses, said fifth lens group includes at least five positive lenses and at least one negative lens, and said sixth lens group includes at least one positive lens, and

wherein said fifth lens group comprises a negative meniscus lens, and a positive lens placed as adjacent to a concave surface of said negative meniscus lens and having a convex surface opposed to the concave surface of said negative meniscus lens.

71. An exposure apparatus according to claim 70, wherein said negative meniscus lens and said positive lens adjacent to the concave surface of said negative meniscus lens are placed between positive lenses in said fifth lens group.

72. A projection optical system located between a first object and a second object, for projecting an image of the first object onto the second object, said projection optical system having:

- a first lens group with positive refracting power, and first lens group being placed between the first and second objects;

a second lens group with negative refracting power, said second lens group being placed between said first lens group and the second object;

a third lens group with positive refracting power, said third lens group being placed between said second lens group and the second object;

a fourth lens group with negative refracting power, said fourth lens group being placed between said third lens group and the second object;

a fifth lens group with positive refracting power, said fifth lens group being placed between said fourth lens group and the second object; and

a sixth lens group with positive refracting power, said sixth lens group being placed between said fifth lens group and the second object,

wherein said first lens group includes at least two positive lenses, said third lens group includes at least three positive lenses, said fourth lens group includes at least three negative lenses, said fifth lens group includes at least five positive lenses and at least one negative lens, and said sixth lens group includes at least one positive lens,

wherein said second lens group comprises a front lens placed as closest to the first object and having negative refracting power with a concave surface to the second object, a rear lens placed as closest to the second object and having negative refracting power with a concave surface to the first object, and an intermediate lens group placed between said front and rear lenses in said second lens group, and

wherein said intermediate lens group includes a positive lens and a negative lens.

73. A projection optical system according to claim 72, wherein the following condition is satisfied when an axial distance from the first object to a first-object-side focal point of the whole of said projection optical system is I and the distance from the first object to the second object is L:

$$1.0 < I/L.$$

74. A projection optical system according to claim 73, wherein said fourth lens group comprises a front lens placed as closest to the first object and having negative refracting power with a concave surface to the second object, a rear lens placed as closest to the second object and having negative refracting power with a concave surface to the first object, and at least one negative lens placed between said front lens in said fourth lens group and said rear lens in said fourth lens group.

75. A projection optical system according to claim 73, wherein said fifth lens group comprises a negative meniscus lens, and a positive lens placed as adjacent to a concave surface of said negative meniscus lens and having a convex surface opposed to the concave surface of said negative meniscus lens.

76. A projection optical system according to claim 75, wherein said negative meniscus lens and said positive lens adjacent to the concave surface of said negative meniscus lens are placed between positive lenses in said fifth lens group.

77. A projection optical system according to claim 76, wherein said fifth lens group comprises a negative lens placed as closest to the second object and having a concave surface opposed to the second object.

78. A projection optical system according to claim 77, wherein said sixth lens group comprises a lens placed as

41

closest to the first object and having a convex surface opposed to the first object.

79. A projection optical system according to claim 74, wherein said fifth lens group comprises a negative meniscus lens, and a positive lens placed as adjacent to a concave surface of said negative meniscus lens and having a convex surface opposed to the concave surface of said negative meniscus lens.

80. A projection optical system according to claim 79, wherein said negative meniscus lens and said positive lens adjacent to the concave surface of said negative meniscus lens are placed between positive lenses in said fifth lens group.

81. A projection optical system according to claim 80, wherein said fifth lens group comprises a negative lens placed as closest to the second object and having a concave surface opposed to the second object.

82. A method for fabricating at least semiconductor devices or liquid crystal display devices by using a projection optical system according to claim 80, comprising the steps of:

illuminating a mask prepared as said first object with light of a predetermined wavelength, said mask being formed *with* a predetermined pattern thereon; and

projecting an image of the pattern on said mask onto a photosensitive substrate prepared as said second object through said projection optical system, thereby performing an exposure process.

83. A projection optical system according to claim 81, wherein said sixth lens group comprises a lens placed as closest to the first object and having a convex surface opposed to the first object.

84. A method for fabricating at least semiconductor devices or liquid crystal display devices by using a projection optical system according to claim 72, comprising the steps of:

illuminating a mask prepared as said first object with light of a predetermined wavelength, said mask being formed *with* a predetermined pattern thereon; and

projecting an image of the pattern on said mask onto a photosensitive substrate prepared as said second object through said projection optical system, thereby performing an exposure process.

85. A method of manufacturing a projection optical system to project an image of a first object onto a second object, comprising the steps of:

*preparing a first lens group with positive power which includes at least two positive lenses;*

*preparing a second lens group with negative power;*

*preparing a third lens group with positive power which includes at least three positive lenses;*

*preparing a fourth lens group with negative power which includes at least three negative lenses;*

*preparing a fifth lens group with positive power which includes at least five positive first lenses and at least one negative first lens, said fifth lens group further including a negative additional lens and a positive additional lens placed adjacent to said negative additional lens;*

*preparing a sixth lens group with positive power which includes at least one positive lens;*

*disposing said first lens group in an optical path between an object surface in which the first object is disposed and said second lens group;*

*disposing said second lens group in an optical path between said first lens group and said third lens group;*

42

*disposing said third lens group in an optical path between said second lens group and said fourth lens group;*

*disposing said fourth lens group in an optical path between said third lens group and said fifth lens group;*

*disposing said fifth lens group in an optical path between said fourth lens group and said sixth lens group; and*

*disposing said sixth lens group in an optical path between said fifth lens group and an image plane in which the second object is disposed.*

86. A method according to claim 85, wherein said step of disposing said fifth lens group comprises the step of placing said negative additional lens and said positive additional lens between two positive first lenses of said at least five positive first lenses.

87. A method according to claim 86, wherein said negative additional lens in said fifth lens group has a concave surface, and said positive additional lens in said fifth lens group has a convex surface facing the concave surface of said negative additional lens.

88. A method according to claim 85, wherein said negative additional lens in said fifth lens group has a concave surface, and said positive additional lens in said fifth lens group has a convex surface facing the concave surface of said negative additional lens.

89. A method according to claim 85, wherein said negative additional lens in said fifth lens group includes a negative meniscus lens having a concave surface, and said positive additional lens in said fifth lens group has a convex surface facing the concave surface of said negative meniscus lens.

90. A method according to claim 86, wherein said negative additional lens in said fifth lens group includes a negative meniscus lens.

91. A method according to claim 85, further comprising the step of disposing an aperture stop between said negative additional lens of said fifth lens group and at least one of the three negative lenses of the fourth lens group.

92. A method according to claim 86, further comprising the step of disposing an aperture stop between said negative additional lens of said fifth lens group and at least one of the three negative lenses of the fourth lens group.

93. A method according to claim 87, further comprising the step of disposing an aperture stop between said negative additional lens of said fifth lens group and at least one of the three negative lenses of the fourth lens group.

94. A method according to claim 88, further comprising the step of disposing an aperture stop between said negative additional lens of said fifth lens group and at least one of the three negative lenses of the fourth lens group.

95. A method according to claim 90, further comprising the step of disposing an aperture stop between said negative additional lens of said fifth lens group and at least one of the three negative lenses of the fourth lens group.

96. A method for fabricating at least a semiconductor device or a liquid crystal device by using a projection optical system manufactured by a method according to claim 85, comprising the steps of:

*disposing a reticle as the first object in the object surface;*

*disposing a substrate as the second object in the image plane;*

*illuminating the reticle with light having a predetermined wavelength; and*

*projecting an image of a pattern formed on the reticle onto the substrate through said projection optical system.*

97. A method for fabricating at least a semiconductor device or a liquid crystal device by using a projection

optical system manufactured by a method according to claim 86, comprising the steps of:

- disposing a reticle as the first object in the object surface;
- disposing a substrate as the second object in the image plane;
- illuminating the reticle with light having a predetermined wavelength; and
- projecting an image of a pattern formed on the reticle onto the substrate through said projection optical system.

98. A method for fabricating at least a semiconductor device or a liquid crystal device by using a projection optical system manufactured by a method according to claim 87, comprising the steps of:

- disposing a reticle as the first object in the object surface;
- disposing a substrate as the second object in the image plane;
- illuminating the reticle with light having a predetermined wavelength; and
- projecting an image of a pattern formed on the reticle onto the substrate through said projection optical system.

99. A method for fabricating at least a semiconductor device or a liquid crystal device by using a projection optical system manufactured by a method according to claim 88, comprising the steps of:

- disposing a reticle as the first object in the object surface;
- disposing a substrate as the second object in the image plane;
- illuminating the reticle with light having a predetermined wavelength; and
- projecting an image of a pattern formed on the reticle onto the substrate through said projection optical system.

100. A method for fabricating at least a semiconductor device or a liquid crystal device by using a projection optical system manufactured by a method according to claim 89, comprising the steps of:

- disposing a reticle as the first object in the object surface;
- disposing a substrate as the second object in the image plane;
- illuminating the reticle with light having a predetermined wavelength; and
- projecting an image of a pattern formed on the reticle onto the substrate through said projection optical system.

101. A method for fabricating at least a semiconductor device or a liquid crystal device by using a projection optical system manufactured by a method according to claim 90, comprising the steps of:

- disposing a reticle as the first object in the object surface;
- disposing a substrate as the second object in the image plane;
- illuminating the reticle with light having a predetermined wavelength; and
- projecting an image of a pattern formed on the reticle onto the substrate through said projection optical system.

102. A method for fabricating at least a semiconductor device or a liquid crystal device by using a projection optical system manufactured by a method according to claim 91, comprising the steps of:

disposing a reticle as the first object in the object surface; disposing a substrate as the second object in the image plane;

- illuminating the reticle with light having a predetermined wavelength; and
- projecting an image of a pattern formed on the reticle onto the substrate through said projection optical system.

103. A method for fabricating at least a semiconductor device or a liquid crystal device by using a projection optical system manufactured by a method according to claim 92, comprising the steps of:

- disposing a reticle as the first object in the object surface;
- disposing a substrate as the second object in the image plane;
- illuminating the reticle with light having a predetermined wavelength; and
- projecting an image of a pattern formed on the reticle onto the substrate through said projection optical system.

104. A method for fabricating at least a semiconductor device or a liquid crystal device by using a projection optical system manufactured by a method according to claim 93, comprising the steps of:

- disposing a reticle as the first object in the object surface;
- disposing a substrate as the second object in the image plane;
- illuminating the reticle with light having a predetermined wavelength; and
- projecting an image of a pattern formed on the reticle onto the substrate through said projection optical system.

105. A method for exposing a pattern formed on a reticle onto a substrate by using a projection optical system manufactured by a method according to claim 85, comprising the steps of:

- disposing the reticle as the first object in the object surface;
- disposing the substrate as the second object in the image plane;
- illuminating the reticle with light having a predetermined wavelength; and
- projecting an image of a pattern formed on the reticle onto the substrate through said projection optical system.

106. A method for exposing a pattern formed on a reticle onto a substrate by using a projection optical system manufactured by a method according to claim 86, comprising the steps of:

- disposing the reticle as the first object in the object surface;
- disposing the substrate as the second object in the image plane;
- illuminating the reticle with light having a predetermined wavelength; and
- projecting an image of a pattern formed on the reticle onto the substrate through said projection optical system.

107. A method of manufacturing an exposure apparatus to expose an image of a first object onto a second object, comprising the steps of:

- providing an illumination optical system to illuminate the first object; and

providing a projection optical system to project the image of the first object onto the second object;  
 wherein said projection optical system comprises:  
 a first lens group with positive power, said first lens group including at least two positive lenses;  
 a second lens group with negative power;  
 a third lens group with positive power, said third lens group including at least three positive lenses;  
 a fourth lens group with negative power, said fourth lens group including at least three negative lenses;  
 a fifth lens group with positive power, said fifth lens group including at least five positive first lenses and at least one negative first lens, said fifth lens group further including a negative additional lens and a positive additional lens placed adjacent to said negative additional lens; and  
 a sixth lens group with positive power, said sixth lens group including at least one positive lens;  
 wherein said first lens group is disposed in an optical path between an object surface in which the first object is disposed and said second lens group;  
 said second lens group is disposed in an optical path between said first lens group and said third lens group;  
 said third lens group is disposed in an optical path between said second lens group and said fourth lens group;  
 said fourth lens group is disposed in an optical path between said third lens group and said fifth lens group;  
 said fifth lens group is disposed in an optical path between said fourth lens group and said sixth lens group; and  
 said sixth lens group is disposed in an optical path between said fifth lens group and an image plane in which the second object is disposed.

108. A method according to claim 107, wherein said negative additional lens and said positive additional lens are placed between two positive first lenses of said at least five positive first lenses.

109. A method according to claim 108, wherein said negative additional lens placed in said fifth lens group has a concave surface, and said positive additional lens in said fifth lens group has a convex surface facing the concave surface of said negative additional lens.

110. A method according to claim 107, wherein said negative additional lens placed in said fifth lens group has a concave surface, and said positive additional lens in said fifth lens group has a convex surface facing the concave surface of said negative additional lens.

111. A method according to claim 107, wherein said negative additional lens in said fifth lens group includes a negative meniscus lens having a concave surface, and said positive additional lens in said fifth lens group has a convex surface facing the concave surface of said negative meniscus lens.

112. A method according to claim 107, wherein said negative additional lens in said fifth lens group includes a negative meniscus lens.

113. A method according to claim 107, wherein said projection optical system further comprises an aperture stop disposed between said negative additional lens of said fifth lens group and at least one of the three negative lenses of the fourth lens group.

114. A method according to claim 108, wherein said projection optical system further comprises an aperture stop disposed between said negative additional lens of said fifth

lens group and at least one of the three negative lenses of the fourth lens group.

115. A method according to claim 109, wherein said projection optical system further comprises an aperture stop disposed between said negative additional lens of said fifth lens group and at least one of the three negative lenses of the fourth lens group.

116. A method according to claim 112, wherein said projection optical system further comprises an aperture stop disposed between said negative additional lens of said fifth lens group and at least one of the three negative lenses of the fourth lens group.

117. A method for fabricating at least a semiconductor device or a liquid crystal device by using an exposure apparatus manufactured by a method according to claim 107, comprising the steps of:

disposing a reticle as the first object in the object surface;  
 disposing a substrate as the second object in the image plane;

illuminating the reticle with light having a predetermined wavelength by using said illumination optical system of said exposure apparatus; and

projecting an image of a pattern formed on the reticle onto the substrate through said projection optical system of said exposure apparatus.

118. A method for fabricating at least a semiconductor device or a liquid crystal device by using an exposure apparatus manufactured by a method according to claim 108, comprising the steps of:

disposing a reticle as the first object in the object surface;  
 disposing a substrate as the second object in the image plane;

illuminating the reticle with light having a predetermined wavelength by using said illumination optical system of said exposure apparatus; and

projecting an image of a pattern formed on the reticle onto the substrate through said projection optical system of said exposure apparatus.

119. A method for fabricating at least a semiconductor device or a liquid crystal device by using an exposure apparatus manufactured by a method according to claim 109, comprising the steps of:

disposing a reticle as the first object in the object surface;  
 disposing a substrate as the second object in the image plane;

illuminating the reticle with light having a predetermined wavelength by using said illumination optical system of said exposure apparatus; and

projecting an image of a pattern formed on the reticle onto the substrate through said projection optical system of said exposure apparatus.

120. A method for fabricating at least a semiconductor device or a liquid crystal device by using an exposure apparatus manufactured by a method according to claim 112, comprising the steps of:

disposing a reticle as the first object in the object surface;  
 disposing a substrate as the second object in the image plane;

illuminating the reticle with light having a predetermined wavelength by using said illumination optical system of said exposure apparatus; and

projecting an image of a pattern formed on the reticle onto the substrate through said projection optical system of said exposure apparatus.

121. A method for fabricating at least a semiconductor device or a liquid crystal device by using an exposure apparatus manufactured by a method according to claim 113, comprising the steps of:

disposing a reticle as the first object in the object surface; 5  
 disposing a substrate as the second object in the image plane;  
 illuminating the reticle with light having a predetermined wavelength by using said illumination optical system of said exposure apparatus; and 10  
 projecting an image of a pattern formed on the reticle onto the substrate through said projection optical system of said exposure apparatus.

122. A method for fabricating at least a semiconductor device or a liquid crystal device by using an exposure apparatus manufactured by a method according to claim 114, comprising the steps of:

disposing a reticle as the first object in the object surface; 15  
 disposing a substrate as the second object in the image plane;  
 illuminating the reticle with light having a predetermined wavelength by using said illumination optical system of said exposure apparatus; and  
 projecting an image of a pattern formed on the reticle 20  
 onto the substrate through said projection optical system of said exposure apparatus.

123. A method for exposing a pattern formed on a reticle onto a substrate by using an exposure apparatus manufactured by a method according to claim 107, comprising the steps of:

disposing the reticle as the first object in the object surface;  
 disposing the substrate as the second object in the image plane; 25  
 illuminating the reticle with light having a predetermined wavelength by using said illumination optical system of said exposure apparatus; and  
 projecting an image of a pattern formed on the reticle 30  
 onto the substrate through said projection optical system of said exposure apparatus.

124. A method for exposing a pattern formed on a reticle onto a substrate by using an exposure apparatus manufactured by a method according to claim 108, comprising the steps of:

disposing the reticle as the first object in the object surface;  
 disposing the substrate as the second object in the image plane;  
 illuminating the reticle with light having a predetermined wavelength by using said illumination optical system of said exposure apparatus; and 35  
 projecting an image of a pattern formed on the reticle 40  
 onto the substrate through said projection optical system of said exposure apparatus.

125. A method of manufacturing an exposure apparatus to expose an image of a first object onto a second object, comprising the steps of:

providing an illumination optical system to illuminate the first object; and 45  
 providing a projection optical system to project the image of the first object onto the second object;  
 wherein said step of providing said projection optical system comprises the steps of:  
 preparing a first lens group with positive power which 50  
 includes at least two positive lenses;

preparing a second lens group with negative power;  
 preparing a third lens group with positive power which includes at least three positive lenses;  
 preparing a fourth lens group with negative power which includes at least three negative lenses;  
 preparing a fifth lens group with positive power which includes at least five positive first lenses and at least one negative first lens, said fifth lens group further including a negative additional lens and a positive additional lens placed adjacent to said negative additional lens;  
 preparing a lens sixth group with positive power which includes at least one positive lens;  
 disposing said first lens group in an optical path between an object surface in which the first object is disposed and said second lens group;  
 disposing said second lens group in an optical path between said first lens group and said third lens group;  
 disposing said third lens group in an optical path between said second lens group and said fourth lens group;  
 disposing said fourth lens group in an optical path between said third lens group and said fifth lens group;  
 disposing said fifth lens group in an optical path between said fourth lens group and said sixth lens group; and  
 disposing said sixth lens group in an optical path between said fifth lens group and an image plane in which the second object is disposed.

126. A method according to claim 125, wherein said step of disposing said fifth lens group comprises the step of placing said negative additional lens and said positive additional lens between two positive first lenses of said at least five positive first lenses.

127. A method according to claim 126, wherein said negative additional lens in said fifth lens group has a concave surface, and said positive additional lens in said fifth lens group has a convex surface facing the concave surface of said negative additional lens.

128. A method according to claim 125, wherein said negative additional lens in said fifth lens group has a concave surface, and said positive additional lens in said fifth lens group has a convex surface facing the concave surface of said negative additional lens.

129. A method according to claim 125, wherein said negative additional lens in said fifth lens group includes a negative meniscus lens having a concave surface, and said positive additional lens in said fifth lens group has a convex surface facing the concave surface of said negative meniscus lens.

130. A method according to claim 125, wherein said negative additional lens in said fifth lens group includes a negative meniscus lens.

131. A method according to claim 125, further comprising the step of disposing an aperture stop between said negative additional lens of said fifth lens group and at least one of the three negative lenses of the fourth lens group.

132. A method according to claim 126, further comprising the step of disposing an aperture stop between said negative additional lens of said fifth lens group and at least one of the three negative lenses of the fourth lens group.

133. A method according to claim 127, further comprising the step of disposing an aperture stop between said negative additional lens of said fifth lens group and at least one of the three negative lenses of the fourth lens group.



projecting an image of a pattern formed on the reticle onto the substrate through said projection optical system of said exposure apparatus.

144. A method for fabricating at least a semiconductor device or a liquid crystal device, comprising the steps of: 5  
 providing a reticle having a predetermined pattern;  
 providing a substrate;  
 illuminating the reticle with light having a predetermined wavelength; and  
 projecting an image of the pattern formed on the reticle onto the substrate by using a projection optical system; 10  
 wherein said projection optical system comprises:  
 a first lens group with positive power, said first lens group including at least two positive lenses;  
 a second lens group with negative power; 15  
 a third lens group with positive power, said third lens group including at least three positive lenses;  
 a fourth lens group with negative power, said fourth lens group including at least three negative lenses;  
 a fifth lens group with positive power, said fifth lens group including at least five positive first lenses and at least one negative first lens, said fifth lens group further including a negative additional lens and a positive additional lens placed adjacent to said negative additional lens; and 20  
 a sixth lens group with positive power, said sixth lens group including at least one positive lens;  
 wherein said first lens group is disposed in an optical path between an object surface in which the reticle is disposed and said second lens group; 30  
 said second group is disposed in an optical path between said first lens group and said third lens group;  
 said third lens group is disposed in an optical path between said second lens group and said fourth lens group; 35  
 said fourth lens group is disposed in an optical path between said third lens group and said fifth lens group;  
 said fifth lens group is disposed in an optical path 40  
 between said fourth lens group and said sixth lens group; and  
 said sixth lens group is disposed in an optical path between said fifth lens group and an image plane at which the substrate is disposed. 45

145. A method according to claim 144, wherein said negative additional lens and said positive additional lens are placed between two positive first lenses of said at least five positive first lenses.

146. A method according to claim 145, wherein said negative additional lens in said fifth lens group has a concave surface, and said positive additional lens in said fifth lens group has a convex surface facing the concave surface of said negative additional lens.

147. A method according to claim 145, wherein said negative additional lens in said fifth lens group includes a negative meniscus lens.

148. A method according to claim 144, wherein said projection optical system further comprises an aperture stop disposed between said negative additional lens of said fifth lens group and at least one of the three negative lenses of the fourth lens group. 60

149. A method according to claim 145, wherein said projection optical system further comprises an aperture stop disposed between said negative additional lens of said fifth lens group and at least one of the three negative lenses of the fourth lens group. 65

150. A method according to claim 146, wherein said projection optical system further comprises an aperture stop disposed between said negative additional lens of said fifth lens group and at least one of the three negative lenses of the fourth lens group.

151. A method according to claim 147, wherein said projection optical system further comprises an aperture stop disposed between said negative additional lens of said fifth lens group and at least one of the three negative lenses of the fourth lens group.

152. A method for exposing a pattern formed on a reticle onto a substrate, comprising the steps of:

providing the reticle having a predetermined pattern;  
 providing the substrate in an image plane;  
 illuminating the reticle with light having a predetermined wavelength; and

projecting an image of the pattern formed on the reticle onto the substrate by using a projection optical system; wherein said projection optical system comprises:

a first lens group with positive power, said first lens group including at least two positive lenses;  
 a lens second group with negative power;  
 a third lens group with positive power, said third lens group including at least three positive lenses;  
 a fourth lens group with negative power, said fourth lens group including at least three negative lenses;  
 a fifth lens group with positive power, said fifth lens group including at least five positive first lenses and at least one negative first lens, said fifth lens group further including a negative additional lens and a positive additional lens placed adjacent to said negative additional lens; and  
 a sixth lens group with positive power, said sixth lens group including at least one positive lens;  
 wherein said first lens group is disposed in an optical path between an object surface in which the reticle is disposed and said second lens group;  
 said second lens group is disposed in an optical path between said first lens group and said third lens group;  
 said third lens group is disposed in an optical path between said second lens group and said fourth lens group;  
 said fourth lens group is disposed in an optical path between said third lens group and said fifth lens group;  
 said sixth lens group is disposed in an optical path between said fifth lens group and the image plane at which the substrate is disposed.

153. A method according to claim 152, wherein said negative additional lens and said positive additional lens are placed between two positive first lenses of said at least five positive first lenses.

154. A method according to claim 153, wherein said negative additional lens in said fifth lens group has a concave surface, and said positive additional lens in said fifth lens group has a convex surface facing the concave surface of said negative additional lens.

155. A method according to claim 153, wherein said negative additional lens in said fifth lens group includes a negative meniscus lens.

156. A method according to claim 152, wherein said projection optical system further comprises an aperture stop disposed between said negative additional lens of said fifth lens group and at least one of the three negative lenses of the fourth lens group.

157. A method according to claim 153, wherein said projection optical system further comprises an aperture stop disposed between said negative additional lens of said fifth lens group and at least one of the three negative lenses of the fourth lens group.

158. A method according to claim 154, wherein said projection optical system further comprises an aperture stop disposed between said negative additional lens of said fifth lens group and at least one of the three negative lenses of the fourth lens group.

159. A method according to claim 155, wherein said projection optical system further comprises an aperture stop disposed between said negative additional lens of said fifth lens group and at least one of the three negative lenses of the fourth lens group.

160. A projection optical system disposed in an optical path between a first surface on which a reticle is arranged and a second surface on which a substrate is arranged, for projecting a pattern of the reticle onto the substrate, comprising:

a first positive lens group having a positive power and disposed in the optical path between said first and second surfaces, said first positive lens group comprising a positive lens having a convex surface and a negative lens having a concave surface disposed near said positive lens and facing said convex surface, and two adjacent positive lenses disposed in an optical path between the positive lens and the second surface and disposed in an optical path between the negative lens and the second surface;

a first negative lens group having a negative power and disposed on an optical path between said first surface and said first positive lens group, said first negative lens group comprising at least three negative lenses;

a second positive lens group having a positive power and disposed in an optical path between said first surface and said first negative lens group, said second positive lens group comprising at least three positive lenses;

a second negative lens group having a negative power and disposed in an optical path between said first surface and said second positive lens group, said second negative lens group comprising at least one lens having a concave surface facing said first surface; and a rear lens group disposed in an optical path between the first positive lens group and the second surface and having a positive power, the rear lens group comprising at least one positive lens;

none of the lenses constructing said projection optical system being a compound lens, and a numerical aperture of said projection optical system at the second surface on which the substrate is arranged comprising at least 0.55.

161. The projection optical system according to claim 160, further comprising an aperture stop disposed in an optical path at a position upstream with respect to said positive lens having said convex surface and said negative lens having said concave surface disposed near said positive lens having said convex surface.

162. The projection optical system according to claim 160, wherein said projection optical system comprises a lens made of fluorite.

163. The projection optical system according to claim 160, wherein said first positive lens group comprises a plurality of lenses having concave surfaces opposite to the second surface respectively.

164. The projection optical system according to claim 163, wherein said projection optical system is telecentric in both a side of the first surface and a side of the second surface.

165. The projection optical system according to claim 160, wherein the first positive lens group comprises a negative lens arranged nearest to the second surface.

166. The projection optical system according to claim 165, further comprising a front lens group disposed in an optical path between said second negative lens group and the first surface, said front lens group comprising at least two lenses.

167. The projection optical system according to claim 160, wherein said projection optical system comprises a lens made of fluorite and said projection optical system is telecentric in both a side of the first surface and a side of the second surface.

168. The projection optical system according to claim 161, wherein said projection optical system comprises a lens made of fluorite and said projection optical system is telecentric in both a side of the first surface and a side of the second surface.

169. An exposure apparatus for exposing a pattern of a reticle onto a substrate, comprising:

an illumination optical system which illuminates the reticle; and

a projection optical system disposed in an optical path between a first surface on which the reticle is arranged and a second surface on which the substrate is arranged, for projecting the pattern of the reticle onto the substrate, said projection optical system comprising:

a first positive lens group having a positive power and disposed in the optical path between said first and second surfaces, said first positive lens group comprising a positive lens having a convex surface, a negative lens having a concave surface disposed near said positive lens and facing said convex surface, and two adjacent positive lenses disposed in an optical path between the positive lens and the second surface and disposed in an optical path between the negative lens and the second surface;

a first negative lens group having a negative power and disposed on an optical path between said first surface and said first positive lens group, said first negative lens group comprising at least three negative lenses;

a second positive lens group having a positive power and disposed in an optical path between said first surface and said first negative lens group, said second positive lens group comprising at least three positive lenses;

a second negative lens group having a negative power and disposed in an optical path between said second positive lens group and said first surface, said second negative lens group comprising at least one lens having a concave surface facing said first surface; and

a rear lens group disposed in an optical path between the first positive lens group and the second surface and having a positive power, the rear lens group comprising at least one positive lens;

none of the lenses constructing said projection optical system being a compound lens, and a numerical aperture of said projection optical system at the second surface on which the substrate is arranged comprising at least 0.55.

170. The exposure apparatus according to claim 169, wherein said projection optical system comprises a lens made of fluorite.

171. The exposure apparatus according to claim 170, further comprising an aperture stop disposed in an optical

path at a position upstream with respect to said positive lens having said convex surface and said negative lens having said concave surface disposed near said positive lens having said convex surface.

172. The exposure apparatus according to claim 169, wherein the two adjacent positive lenses in the first positive lens group have concave surfaces opposite to the second surface respectively.

173. The exposure apparatus according to claim 172, wherein said projection optical system is telecentric in both a side of the first surface and a side of the second surface.

174. The exposure apparatus according to claim 170, wherein said illumination optical system comprises an excimer laser supplying a light having a wavelength of 193 nm.

175. The exposure apparatus according to claim 169, wherein the first positive lens group and said comprises a negative lens arranged nearest to the second surface.

176. The exposure apparatus according to claim 169, further comprising a front lens group disposed in an optical path between said second negative lens group and the first surface, said front lens group comprising at least two lenses.

177. The exposure apparatus according to claim 169, wherein said projection optical system is telecentric in both a side of the first surface and a side of the second surface.

178. The exposure apparatus according to claim 170, wherein said projection optical system is telecentric in both a side of the first surface and a side of the second surface.

179. The exposure apparatus according to claim 176, wherein said projection optical system is telecentric in both a side of the first surface and a side of the second surface.

180. A method of manufacturing a semiconductor device or a liquid crystal device by using the exposure apparatus according to claim 169, said method comprising the steps of:

- disposing a reticle on said first surface;
- disposing a substrate on said second surface;
- illuminating said reticle with light having a predetermined wavelength by using said illumination optical system of said exposure apparatus; and
- projecting an image of a pattern formed on said reticle onto said substrate by using said projection optical system of said exposure apparatus.

181. A method of manufacturing a semiconductor device or a liquid crystal device by using the exposure apparatus according to claim 170, said method comprising the steps of:

- disposing a reticle on said first surface;
- disposing a substrate on said second surface;
- illuminating said reticle with light having a predetermined wavelength by using said illumination optical system of said exposure apparatus; and
- projecting an image of a pattern formed on said reticle onto said substrate by using said projection optical system of said exposure apparatus.

182. A method of manufacturing a semiconductor device or a liquid crystal device by using the exposure apparatus according to claim 171, said method comprising the steps of:

- disposing a reticle on said first surface;
- disposing a substrate on said second surface;
- illuminating said reticle with light having a predetermined wavelength by using said illumination optical system of said exposure apparatus; and
- projecting an image of a pattern formed on said reticle onto said substrate by using said projection optical system of said exposure apparatus.

183. A method of manufacturing a semiconductor device or a liquid crystal device by using the exposure apparatus according to claim 172, said method comprising the steps of:

- disposing a reticle on said first surface;
- disposing a substrate on said second surface;
- illuminating said reticle with light having a predetermined wavelength by using said illumination optical system of said exposure apparatus; and
- projecting an image of a pattern formed on said reticle onto said substrate by using said projection optical system of said exposure apparatus.

184. A method of manufacturing a semiconductor device or a liquid crystal device by using the exposure apparatus according to claim 173, said method comprising the steps of:

- disposing a reticle on said first surface;
- disposing a substrate on said second surface;
- illuminating said reticle with light having a predetermined wavelength by using said illumination optical system of said exposure apparatus; and
- projecting an image of a pattern formed on said reticle onto said substrate by using said projection optical system of said exposure apparatus.

185. A method of manufacturing a semiconductor device or a liquid crystal device by using the exposure apparatus according to claim 174, said method comprising the steps of:

- disposing a reticle on said first surface;
- disposing a substrate on said second surface;
- illuminating said reticle with light having a predetermined wavelength by using said illumination optical system of said exposure apparatus; and
- projecting an image of a pattern formed on said reticle onto said substrate by using said projection optical system of said exposure apparatus.

186. A method of manufacturing a semiconductor device or a liquid crystal device by using the exposure apparatus according to claim 175, said method comprising the steps of:

- disposing a reticle on said first surface;
- disposing a substrate on said second surface;
- illuminating said reticle with light having a predetermined wavelength by using said illumination optical system of said exposure apparatus; and
- projecting an image of a pattern formed on said reticle onto said substrate by using said projection optical system of said exposure apparatus.

187. A method of manufacturing a semiconductor device or a liquid crystal device by using the exposure apparatus according to claim 176, said method comprising the steps of:

- disposing a reticle on said first surface;
- disposing a substrate on said second surface;
- illuminating said reticle with light having a predetermined wavelength by using said illumination optical system of said exposure apparatus; and
- projecting an image of a pattern formed on said reticle onto said substrate by using said projection optical system of said exposure apparatus.

188. A method of manufacturing a semiconductor device or a liquid crystal device by using the exposure apparatus according to claim 177, said method comprising the steps of:

57

*disposing a reticle on said first surface;*  
*disposing a substrate on said second surface;*  
*illuminating said reticle with light having a predetermined wavelength by using said illumination optical system of said exposure apparatus; and*  
*projecting an image of a pattern formed on said reticle onto said substrate by using said projection optical system of said exposure apparatus.*  
 189. A method of manufacturing a semiconductor device or a liquid crystal device by using the exposure apparatus according to claim 178, said method comprising the steps of:  
*disposing a reticle on said first surface;*  
*disposing a substrate on said second surface;*  
*illuminating said reticle with light having a predetermined wavelength by using said illumination optical system of said exposure apparatus; and*

58

*projecting an image of a pattern formed on said reticle onto said substrate by using said projection optical system of said exposure apparatus.*  
 190. A method of manufacturing a semiconductor device or a liquid crystal device by using the exposure apparatus according to claim 179, said method comprising the steps of:  
*disposing a reticle on said first surface;*  
*disposing a substrate on said second surface;*  
*illuminating said reticle with light having a predetermined wavelength by using said illumination optical system of said exposure apparatus; and*  
*projecting an image of a pattern formed on said reticle onto said substrate by using said projection optical system of said exposure apparatus.*

\* \* \* \* \*