

(No Model.)

3 Sheets—Sheet 1.

F. TARDIF & W. WETHERED.  
CAN LABELING MACHINE.

No. 524,916.

Patented Aug. 21, 1894.

Fig. 1.

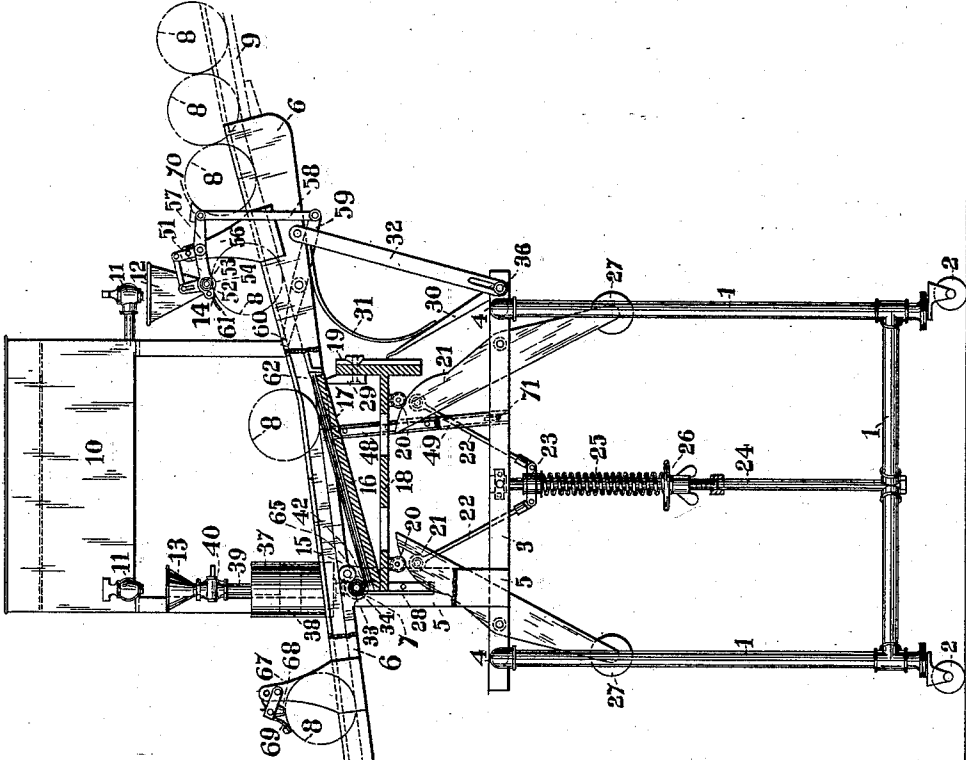
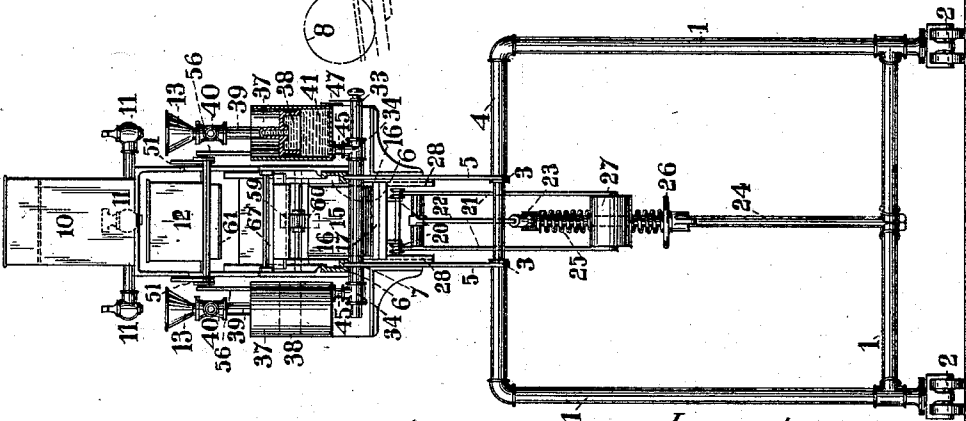

Fig. 2.



Witnesses:  
 E. A. Brandau.  
 Wilson D. Bent, Jr.

Inventors:  
 Frederick Tardif  
 Woodward Wethered  
 John Richards  
 Atty



(No Model.)

3 Sheets—Sheet 3.

F. TARDIF & W. WETHERED.  
CAN LABELING MACHINE.

No. 524,916.

Patented Aug. 21, 1894.

Fig. 11.

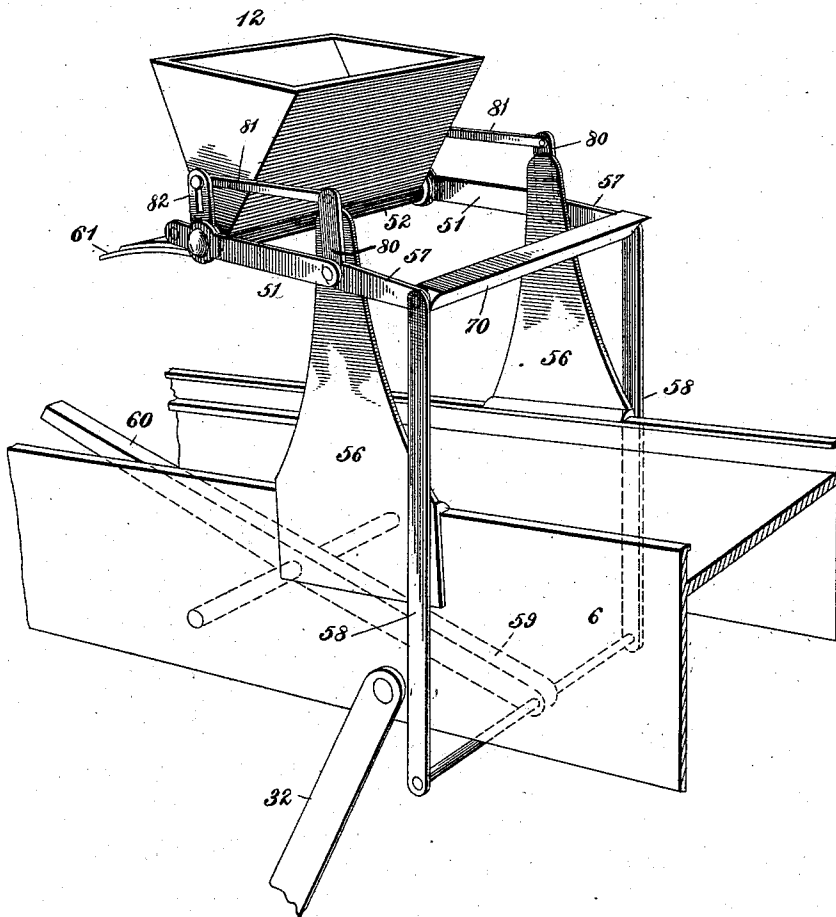

WITNESSES

*Edw. S. Durall, Jr.*  
*Wm. L. Boyden*

INVENTORS  
*Frederick Tardif*  
*Woodworth Wethered,*  
per *Fred Wacker*  
Attorney

# UNITED STATES PATENT OFFICE.

FREDERICK TARDIF AND WOODWORTH WETHERED, OF SAN FRANCISCO, CALIFORNIA, ASSIGNORS TO SAID TARDIF AND LOUIS SLOSS, JR., OF SAME PLACE.

## CAN-LABELING MACHINE.

SPECIFICATION forming part of Letters Patent No. 524,916, dated August 21, 1894.

Application filed January 14 1893. Serial No. 458,396. (No model.)

*To all whom it may concern:*

Be it known that we, FREDERICK TARDIF and WOODWORTH WETHERED, citizens of the United States, residing in the city and county of San Francisco, State of California, have invented certain new and useful Improvements in Machinery for Affixing Labels on Cans or other Cylindrical Packages; and we hereby declare the following specification and the drawings therewith to be a full, true, and exact description of our improvements.

Our invention relates to machines for automatically affixing labels by means of paste or other mucilaginous material, and consists in various mechanical agents and expedients to distribute the paste, first on the inner face of the label, and then on the overlapping end thereof, means of feeding or presenting the labels, stretching and disposing the same with exactness around the can or package, and forming a complete joint at the lap where the ends meet.

Our invention includes for this purpose various mechanical devices and functions that will be pointed out and explained in connection with the drawings herewith, in which—

Figure 1 is a side elevation, partially in section, showing a labeling machine constructed according to our invention. Fig. 2 is an end view of the same machine. Fig. 3 is a partial plan view showing the top of the runway, and some of its connected details. Fig. 4 is an enlarged partial section through the mechanism for pasting the lap of the labels. Fig. 5 is an enlarged view of a distributing valve or tube for applying paste on the lap of the labels. Fig. 6 is an end view of Fig. 5. Fig. 7 is an enlarged view, partially in section, through the mechanism for distributing the paste over the exterior of the cans, and for the inner side of the labels. Fig. 8 is a transverse section through one of the adjustable guides for holding and adjusting the labels as they are presented for pasting. Fig. 9 is a section through the label-supporting table, showing the arrangement of adjustable guides or gages to accommodate the varying widths of the labels. Fig. 10 is an enlarged transverse section through the devices for pasting the lap of the label. Fig. 11 is an enlarged detail perspective view showing the construction and arrangement of the paste hopper and the leverage mechanism for operating the

valve which is located in the bottom of said hopper.

Similar figures of reference denote corresponding parts in the different figures of the drawings.

The main supporting frame (1) we make preferably of metal tubes, joined and connected as shown, the whole being mounted on casters (2) so the machine can be readily moved about or out of the way when not in use.

On the top of the main frame (1) are placed two cross rails (3) attached to the two members (4). Fastened to these two rails (3) are vertical standards (5) on which is pivoted at (7) the main table or run-way (6) containing the principal mechanism of the machine. This main table or frame (6) is set adjustably in an inclined or diagonal position as shown in Fig. 1, so the cans or packages (8) are fed in on a chute (9) and roll through the machine, their gravity performing the various operations of pasting and applying the labels, as will be hereinafter explained.

On the top of the machine is provided a tank (10) to contain paste or other liquid mucilaginous matter that can be drawn off as required by the faucets (11) into the hoppers (12) and (13), from where it is distributed to the exterior of the cans at (14) and to the lap of the labels at (15).

The labels (16) to be applied are placed on the platen (17) which is the top part of a triangular frame composed of members (17) (18) (19) as shown in Fig. 1. This frame rests on the rollers (20) bearing on the pivoted cam levers (21) and is free to move up or down as these levers are raised or depressed, moving precisely parallel by reason of the links (22), attached to a cross-head (23), which slides up and down on the rod (24). The cam-levers (21) are formed at their top with a cam shape, or a developed curve, where they bear on the rollers (20), as shown in Fig. 1, so that as the levers assume different positions, or as the weighted ends (27) descend, the upward pressure on the rollers (20), and on the platen (16), will be uniform irrespective of the angle at which the levers stand. The shape of this curve on the bearing ends of the levers (21) is made to a developed curve so that the upward pressure and leverage is uniform irrespective of the angle at which the levers stand

and can be made to compensate for the diminishing weight of the labels as the platen 17 ascends. We are aware that such levers are known and used for a similar purpose, but of the simple kind exerting a force dependent on their angular position, and thus insure a perfectly uniform pressure and resistance to the withdrawal of the labels (16) from beneath the tube (34).

On the rod (24) is placed a coil spring (25) which in part supports the weight of the label frame, or compensates for the weight of the labels, as the thumb nut (26) is adjusted up or down, but the main part of the weight of this label frame, and labels on the platen (17) rest on the levers (21) which have counter-balancing weights (27) at their outer ends as shown. The mechanism just described maintains a constant and uniform upward thrust on the platen (17) causing it to rise as the labels are removed.

Besides the links (22) there are provided at each side corner-guides (28), shown in section at Fig. 8, which serve to steady the platen (17), and also to adjust the pile of labels laterally at that end, so as to conform to the position of the run-way (6).

The angle or inclination of the platen (17) is made adjustable by means of the movable member (29), and any tendency to downward movement, caused by the weight of the cans (8) rolling over the top of the labels (16), is checked by the pawl or detent (30) held in position by the spring (31) or by any other suitable means to prevent reaction of the platen 17. The angle of the main table or frame (6) is adjustable by means of the slotted strut (32) held by the bolt or screw (36).

To provide for variation in the width of the labels, there are adjustable guides (48), shown in the section Fig. 9, and also in the plan view, Fig. 3. These guides or gages (48) are supported on the bars (49), adjustably attached to the rails at (71), or in any other suitable manner so as to be adjustable transverse to the platen (17), by means of the screws (50), so the labels (16) when of different widths are kept central with respect to the platen (17) and the cans (8).

Referring now to the devices for applying the paste, the hopper (12), Figs. 1 and 7, is with the hinged wiper or distributing brush (61), supported by radial arms 51 rigidly secured at their ends upon the brackets 56 fastened to the top of the frame or runway 6—see Fig. 11. This hopper (12) is formed integrally with a cylindrical shell or pipe (52), into which is fitted a valve or tube (53) corresponding in most respects to the one (33), shown in the enlarged view Fig. 5, provided with slots or perforations (54) (55) the former coinciding with the slot (76) in the outer shell or tube (52) where the paste is discharged. This tube has an oscillating movement, and is operated automatically by means of the bell cranks (57), which is pivoted to the brackets 56 links, (58), and lever (59), as shown in

the side view, Fig. 1. The bell cranks are pivotally mounted upon the uprights 56. The rear arms 57 of these bell cranks are pivoted to the upper ends of the links 58, there being a connection 70 between the outer ends of said rear arms of the bell cranks. The forward arms 80 of the bell cranks are attached by means of links 81 to the slotted arms 82, which are affixed to the paste-distributing tube. When the bell cranks oscillate, these links 81 by acting on the arms 82, rotate the paste-distributing valve in the proper manner as will be hereinafter explained. This lever (59) is actuated by the gravity of the cans (8) rolling over and depressing the end (60) of the lever (59), at the same time by means of the linkage just described, causing a partial rotation of the tube (53), and permitting intermittently, as each can passes, a quantity of paste to escape from the hopper (12) on the cans (8), and to the brush or wiper (61), thus covering uniformly a portion of the circumference of the cans with paste, in such position that as the can rolls on down the inclosed runway (6) the pasted portion of the circumference comes in contact at (62) with the pile of labels (16).

In Fig. 7, a can is shown directly beneath the paste valve, which is represented as closed so that no paste can issue therefrom. This can has just arrived at this position, and simultaneously with its being there, the preceding can is depressing the end 60 of lever 59 which results in opening the paste-valve and discharging the paste upon the surface of the can which is directly below said valve and it also results in lifting the detent and allowing the following can to pass beneath the same. The paste-valve 53 is therefore not opened until a can gets directly beneath it. Then it is opened sufficiently long to permit the discharge of enough paste upon a portion of the surface of the can. Then it closes as the can leaves it and the wiper 61 spreads the paste over the can surface. The pasted can rolls on toward the end 60 of lever 59 and as it strikes and depresses it, resulting in again lifting the detent, the following can which was admitted at the previous lifting of the detent, will have arrived at the position shown in Fig. 7, where it is ready to receive its coat of paste, while the next following can will be admitted past the detent. At the same time the lever (59) is depressed, and as the can, being pasted, passes the wiper (61) the detent (70) formed on the bell crank (57) is raised, permitting another can to follow, as indicated in Fig. 1, so the operation goes on intermittently and automatically. The outer label adheres to the can (8) and is wrapped around its periphery as the can rolls on, to the position indicated in the enlarged view Fig. 4, the label extending from (63) to (64) on the can as indicated.

Referring next to pasting the lap of the labels, and especially to Figs. 2 and 4, liquid paste or mucilaginous matter is fed from the

hopper (12) by gravity alone, but from the  
 hoppers or funnels (13), by means of com-  
 pressing cylinders (37) and pistons (38), one  
 of which is shown in section in Fig. 2. The  
 5 paste falls from the tank (10) into the fun-  
 nels (13), and thence through the pipes (39)  
 until the cylinders (37) are filled, then the  
 cocks (40) are closed and the weight of the  
 pistons (38) and their connected parts rests  
 10 on the fluid (41) forcing it down into the pipe  
 or cylinder (34), and out at the perforations  
 (35) and (42) on the inner surface of the label  
 (43), being pasted, as shown in Fig. 4. The  
 liquid enters the tube (33) through inlet ap-  
 15 ertures (44), shown in the enlarged view Fig.  
 5. These apertures (44) coincide when in  
 working position with the two pipes (45) lead-  
 ing from the cylinders (37) to the horizontal  
 pipe (34), Fig. 2. In case of obstruction in  
 20 the slot (35), in the tube (33), this slot is  
 turned to coincide with one (46) in the pipe  
 (34), so the former can be cleaned, the supply  
 of fluid being at the same time cut off from  
 the perforations (44). The supply of the  
 25 pasting fluid passing through the tube (33)  
 for the lap of the label, as shown in Fig. 4, is  
 regulated by the position of the tube, indi-  
 cated by a pointer (47), as shown in Fig. 6.  
 The same result can be attained by giving the  
 30 tube 33 an automatic oscillating movement  
 by devices actuated by the gravity of the can  
 8 as it rolls over this portion of the runway.  
 This depends upon the fluidity of the paste  
 used and we need not include such devices in  
 35 our present invention. The pointer 47 is af-  
 fixed to the tube 33 near the end thereof as is  
 clearly shown in Fig. 5. When the apertures  
 44 in the tube 33, coincide with the supply  
 pipes 45, the pointer 47 will be in its vertical  
 40 position as shown in Fig. 6 where it points to  
 the figure 2. When in this position the slot  
 35 will coincide with the slot 42, so that paste  
 will be delivered upon the labels. By turn-  
 ing the tube 33 to one side or the other and  
 45 placing the pointer upon figures 1 or 3, the  
 valve can be closed and the discharge of paste  
 stopped.

Referring to Figs. 1, 4 and 10, the label (43)  
 is, by the rolling of the can (8), withdrawn  
 50 from beneath the tube (34) where it has been  
 exposed to the paste, issuing through the ap-  
 erture (42). At the same time some tension  
 is given the label by the roller (65), which if  
 required, may also be covered with paste by  
 55 means of a slot (66) in the pipe (34), and a  
 corresponding slot in tube (33). The upward  
 thrust of the platen (17) presses the labels  
 (16) against the pipe (34), causing by friction  
 there enough force to stretch the label as  
 60 shown. The tension of the label tends to re-  
 volve the can on its axis and cause it to slip  
 on the runway (6). This we prevent when  
 required by roughening the surface of the  
 runway as at 77 in Fig. 4 by means of sand  
 65 paper, gum cloth or any other suitable sub-  
 stance to increase the traction of the can, and  
 thus resist the slipping action and permit the

required tension of the label (43). The can  
 then rolls on to receive the final operation  
 of pressing down and smoothing the lap at  
 70 (67) Figs. 1 and 10, where the hinged and  
 flexible pressing pad (68) performs this press-  
 ing and smoothing operation, and is at the  
 end of the lap of the label, lifted clear of the  
 can by means of the wiper (69). These de- 75  
 vices are mounted on a hinged lever 75 re-  
 ceiving light pressure from a spring 96, as  
 shown in Fig. 10. From here the can rolls  
 off completed. The lever 75 when near its  
 horizontal position rests on a lug or pin 97 80  
 which keeps it from dropping too low after  
 the can has passed. The wiper arm 69 ex-  
 tends downward somewhat below the pressing  
 pad 68 so that as the can rolls beneath the  
 arm 69, it will lift said arm and consequently 85  
 lift the pad 68 clear of the can so that in this  
 way at the end of the lap of the label the  
 presser is lifted off the can. The arm 69 is  
 therefore so timed or placed in respect to the  
 pad 68 that the latter is lifted clear of the lap 90  
 in order that any paste pressed out of the lap  
 will not adhere to the pad and thus prevent  
 it from slipping freely over the following can.  
 This is more clearly seen by referring to the  
 enlarged detail sectional view, Fig. 10. This 95  
 wiper 69 is thought to serve a useful purpose  
 because it clears the pad 68 from the can as  
 soon as the pressing operation is ended and  
 prevents the pad from uselessly rubbing upon  
 the can surface after it leaves the label and 100  
 thereby retarding the free rolling movement  
 of the can. In these various operations it  
 will be seen that the only operative force em-  
 ployed is the gravity of the cans, which force  
 is controlled by the inclination of the runway 105  
 (6), and feeding frame (9), and that the pro-  
 cesses are as rapid as the rolling movement,  
 and required distance between the cans will  
 permit, also that the operation of the machine  
 is automatic and continuous when once ad- 110  
 justed, until the stock of labels on the platen  
 (17) is exhausted.

Having thus described the nature and ob-  
 jects of our invention and the method of con- 115  
 structing and applying the same, what we  
 claim as new, and desire to secure by Letters  
 Patent, is—

1. In a can-labeling machine, an inclined  
 gravity runway provided with paste-distrib- 120  
 uting apparatus for the outside of the cans,  
 consisting of a hopper, slotted outer and inner  
 tubes beneath and connected with the hop-  
 per, as herein described, the inner or supply-  
 ing tube operated by a lever acted upon by  
 the rolling cans, so as to permit a discharge 125  
 of paste for each can that passes, in the man-  
 ner substantially and for the purposes de-  
 scribed.

2. In a can-labeling machine, an inclined  
 runway down which the cans may roll by their 130  
 gravity, a paste-distributing apparatus for the  
 exterior of cans attached at, or near, the high-  
 end of the runway, an oscillating, slotted,  
 feed-tube to permit intermittently the escape

of paste as each can passes, a lever for operating this tube and acting coincidentally therewith, a detent that will permit a can to pass beneath the paste-distributing apparatus

5 each time a can rolls away from the same and over the operating lever, substantially in the manner described.

3. In a can-labeling machine, an inclined runway in combination with an adjustable label-supporting platen or platform beneath, the latter supported by means of weighted cam levers, having a developed or parabolic contour of the bearing faces so that the pressure on the platen will be the same and uniform

10 irrespective of the angle at which the levers stand, the levers bearing on rollers beneath the label platform or platen so as to avoid friction, and permit a free upward movement

15 of the platen as the labels are removed from its top, and spring connections arranged between the weighted levers so as to have a yielding action thereon in the manner substantially as and for the purposes specified.

4. In a can-labeling machine, an inclined adjustable runway down which the cans may roll; paste-distributing devices, as herein described, for applying paste to the exterior of the can and to the lap of the labels; a label-supporting platen or platform beneath supported by weighted cam levers and held in position longitudinally by means of links; a vertical guiding crosshead and rod, a spring around this rod so the upward pressure of the latter, acting on the links, will prevent any

25 play in the joints, and thus maintain a steady position of the label-supporting platen, in the manner substantially as described and for the purposes set forth.

5. In a can-labeling machine, an adjustable inclined runway down which the cans will roll by their gravity; paste-distributing apparatus in connection therewith for the exterior of the cans and also for the lap of the labels; an adjustably-supported label platen or platform beneath the runway sustained by means of weighted cam levers bearing at or near the corners thereof, the platen adjustable in respect to its supports so its inclination can be made to coincide with or suit the

45 position of the runway, if the latter be set at greater or less inclination so the rolling cans will press upon the labels with the required force to cause the latter to adhere, in the manner and for the purposes substantially as described.

6. In a can labeling machine, the combination of an inclined runway adjustably supported on the main frame, paste distributing apparatus for the exterior of the cans and for the lap substantially as described, a label-supporting platen or platform, weighted levers for sustaining the same so as to raise and present the labels to the can as they roll over the said platform, and side gages or

65 guides supported on bars adjustably attached

to the rails of the main frame so as to be transversely adjustable to the platen by screws so that the labels may be held centrally with respect to the runway and the rolling cans irrespective of such variations in the width of the labels as occur in preparing the same, substantially as described.

7. In a can-labeling machine, as herein described, paste-distributing apparatus for the laps of the labels, consisting of a slotted outer pipe or tube and a slotted adjustable inner tube fitting therein, the inner pipe having inlets for the liquid paste, and an outlet slot in contact with the laps of the labels to be prepared, and the outer tube having a clearing slot whereby the perforations in the inner tube can be inspected and cleared when the latter is turned in a position to shut off the supply of paste from the outer tube, in the manner and for the purposes substantially as described.

8. In a can-labeling machine, a runway for the cans, inclined in position so the cans by their gravity will roll down and perform the label-pasting operations herein described, in combination therewith apparatus for applying paste to the exterior of the can and to the lap of the labels, as herein shown, a hinged pressing pad to fold and compress the laps of the labels, formed integrally with a wiper connected with the pressing pad, and depending alongside of and below it so as to be struck by the can as it leaves the pad, the result of which contact will lift the pad clear of the label and can when the end of the label is reached, in the manner substantially as herein set forth and described.

9. In a can-labeling or other machine, a feeding platform having vertical adjustment and thrust, supported on cam levers, the bearing surfaces of which are formed with a curve, as herein described, so the upward pressure will be uniform at all angles within the lever's range; links, to produce parallel movement and a sliding cross head to hold the feeding platen or platform level, and thus presenting the function of guides or slides for the same, in the manner substantially and for the purposes described.

10. In a can-labeling machine, the combination of a runway, a label-supporting platform, the pivoted and weighted levers bearing beneath said platform, the links connected to said levers and a spring acting on said links to cause an upward pressure on the label platform, substantially as described.

In testimony whereof we have hereunto affixed our signatures in the presence of two witnesses.

FREDERICK TARDIF.  
WOODWORTH WETHERED.

Witnesses:  
ALFRED A. ENQUIST,  
WILSON D. BENT, Jr.