

(No Model.)

4 Sheets—Sheet 1.

L. K. JOHNSON & A. A. LOW.
TYPE SETTING APPARATUS.

No. 522,714.

Patented July 10, 1894.

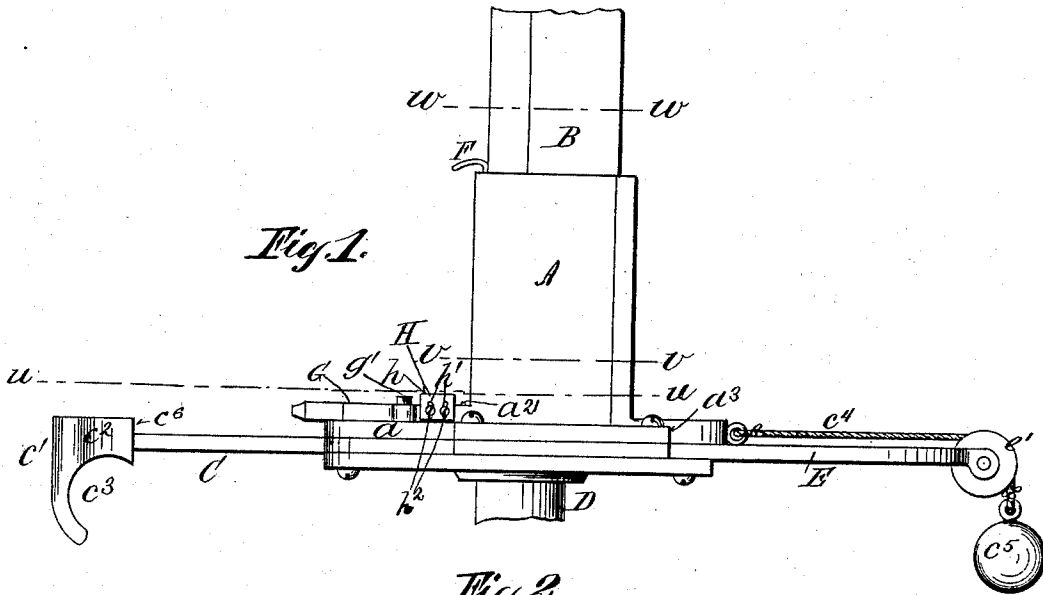

Fig. 1.

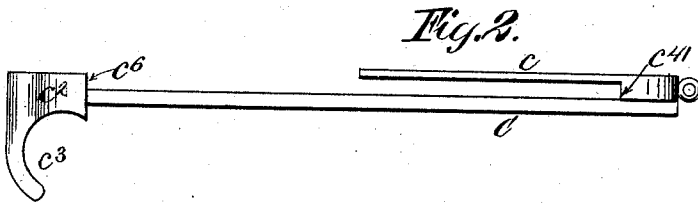

Fig. 2.

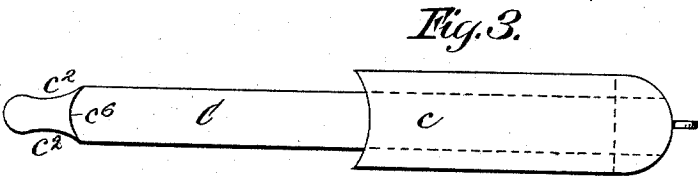

Fig. 3.

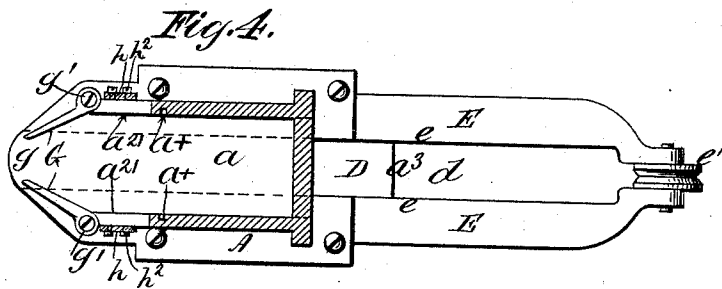

Fig. 4.

Witnesses:
D. W. Gardner.
Feodor Hirsch

Inventors:
Louis K. Johnson
Abbot A. Low
By their attorney
George William Miatt

L. K. JOHNSON & A. A. LOW.
TYPE SETTING APPARATUS.

No. 522,714.

Patented July 10, 1894.

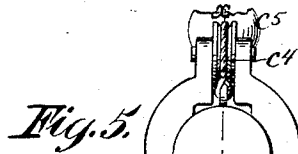

Fig. 6.

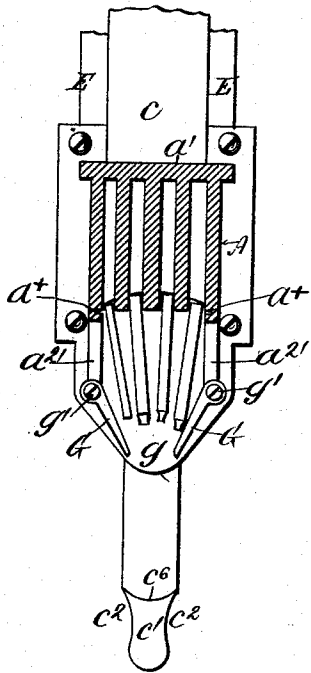

Fig. 7.

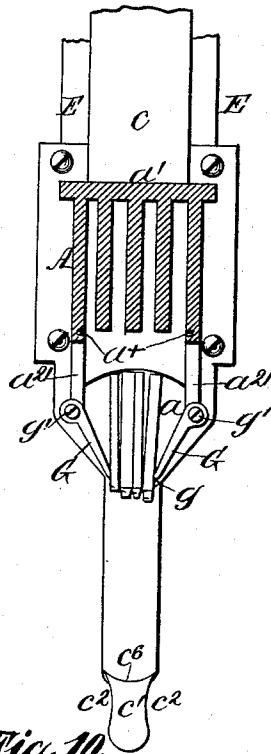

Fig. 8.

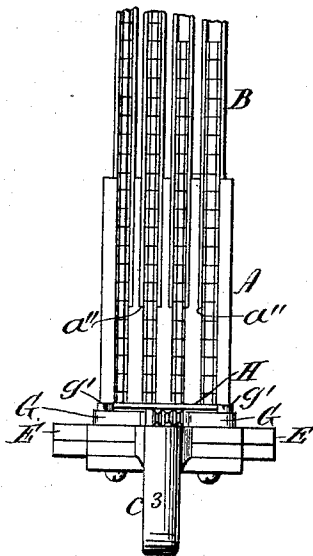

Fig. 9.

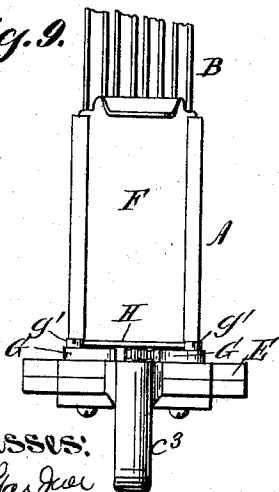
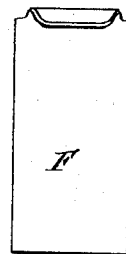

Fig. 10.



Witnesses:
W. Gardner
Pedro Hirsch

Inventors:
Louis K. Johnson
Abbot A. Low
 By their Attorney
George William Meath

L. K. JOHNSON & A. A. LOW.
TYPE SETTING APPARATUS.

No. 522,714.

Patented July 10, 1894.

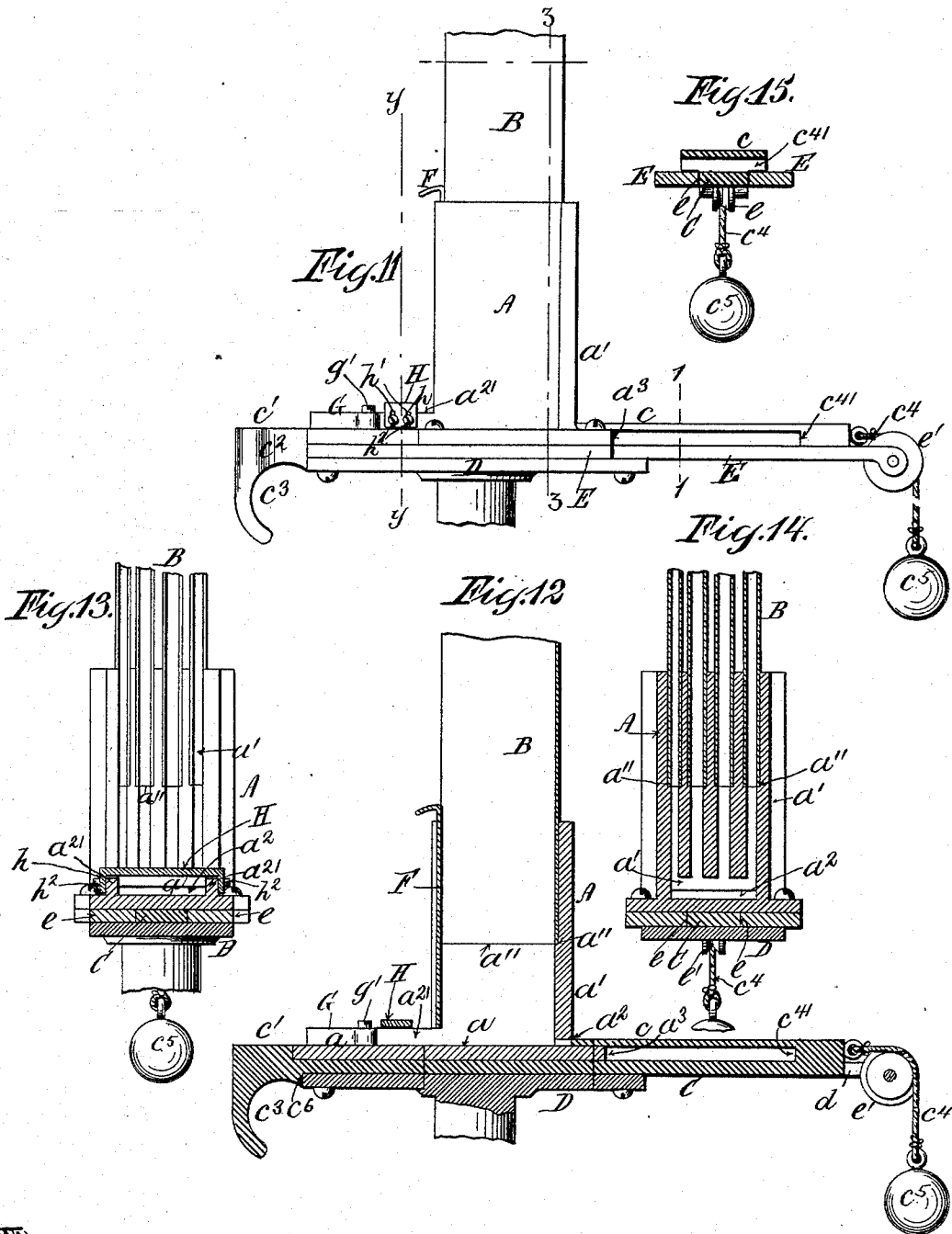

Witnesses:
D. W. Gardner.
Fedor Hirsch

Inventors:
Louis K. Johnson
Abbot. A. Low
By their attorney
George William Smith

L. K. JOHNSON & A. A. LOW.
TYPE SETTING APPARATUS.

No. 522,714.

Patented July 10, 1894.

Fig. 16.

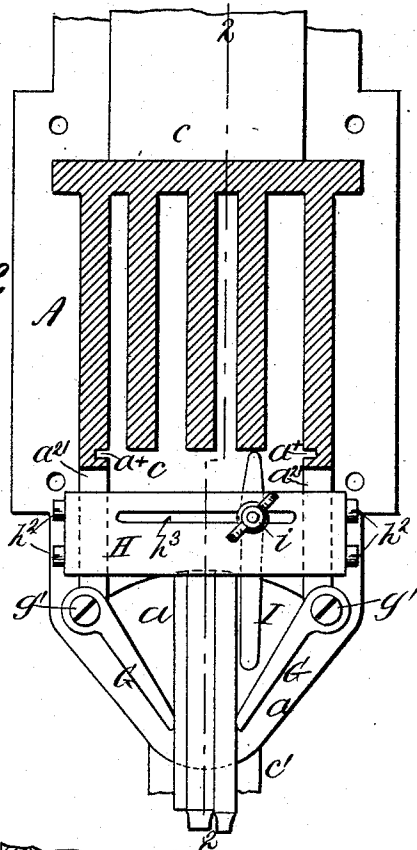

Fig. 18.

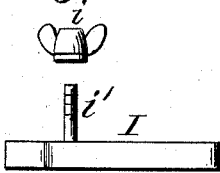

Fig. 19.

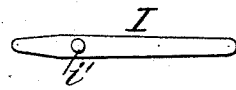
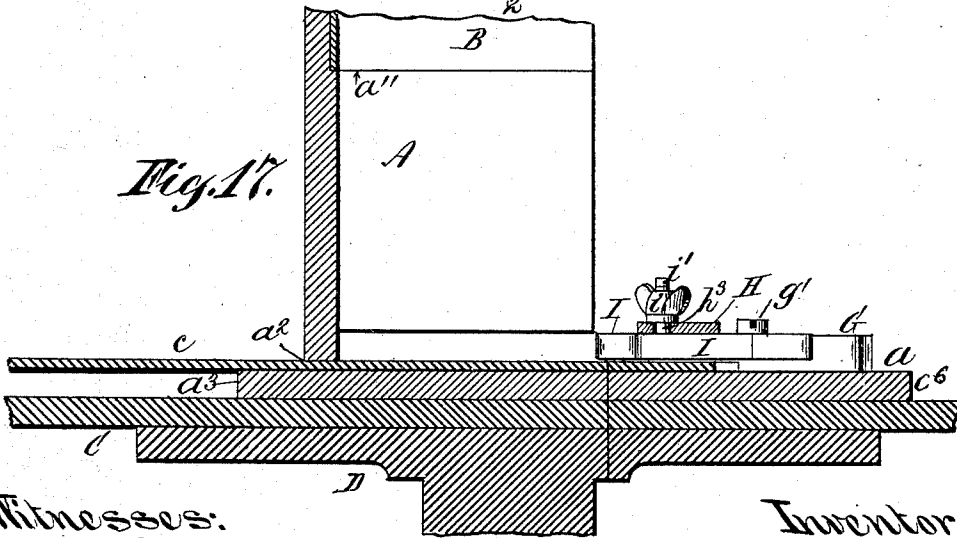

Fig. 17.



Witnesses:

D. W. Gardner.

Fred. Hirsch

Inventors:

Louis K. Johnson

Abbot A. Low

By their attorney

George William Miath

UNITED STATES PATENT OFFICE.

LOUIS K. JOHNSON AND ABBOT A. LOW, OF BROOKLYN, ASSIGNORS TO THE
ALDEN TYPE MACHINE COMPANY, OF NEW YORK, N. Y.

TYPE-SETTING APPARATUS.

SPECIFICATION forming part of Letters Patent No. 522,714, dated July 10, 1894.

Application filed December 4, 1893. Serial No. 492,664. (No model.)

To all whom it may concern:

Be it known that we, LOUIS K. JOHNSON and ABBOT AUGUSTUS LOW, citizens of the United States, residing in the city of Brooklyn, in the county of Kings and State of New York, have invented certain new and useful Improvements in Type-Setting Apparatus, of which the following is a specification, sufficient to enable others skilled in the art to which the invention appertains to make and use the same.

Our invention is designed to render practicable the withdrawal and setting of a plurality of types, or types and spaces, at a single operation of the hand of the compositor. Heretofore provision has been made for grouping and supporting type containing channels in such relation to each other as to effect the forwarding simultaneously from the channels of types composing a word, &c., but in that case the types advanced into position to be grasped by the fingers of the compositor without coming together laterally,—each type being simply pushed from its containing channel in a straight line parallel with the walls of the channel. As a consequence the types rested loosely upon their edges on the type supporting platform and were liable to become disarranged, the inner types and spaces especially being apt to fall over "on a flat," and impair the effectiveness of this system of type setting. Our improvements are designed to overcome these difficulties, and to render the forwarding and assembling of the types and spaces certain and uniform. In fact we control the types and spaces positively until grasped by the finger of the operator, causing them to converge toward each other and come together centrally while under the control of a guard which prevents their turning on their longitudinal axes.

Our invention consists first, in the combination and arrangement with a plurality of type containing channels and a type forwarder common to all, of a type platform in front of the channels formed with converging guide walls by which the types as they advance are positively assembled together and sustained laterally with their front edges extending over the front edge of the platform

in position to be grasped by the fingers of the compositor. An incidental feature in this connection consists in making the said converging guide walls adjustable in inclination with relation to each other so as to conform to variations in the thicknesses of the types and spaces to be used.

The second feature of our invention consists in forming the type forwarder with a concave front edge for contact with the heels of the types to be forwarded into position upon the type platform. By this construction we cause the types to gradually converge as they leave their channels,—the heels of the types conforming to the curved surface of the pusher as they advance from the control of the side walls of the channels,—the convexity of the edge of the pusher being such as to cause the faces of the types to approach each other with their bodies at such angles, with relation to each other and to the converging guide walls of the type platform, that violent contact is avoided,—the front ends of the types advancing gently to and between the outer ends of the converging guide walls which then confine the type together laterally, so that the continued advance of the pusher causes them to come together in parallel lines and with their flat sides in contact.

The third feature of our invention consists in the use in conjunction with the features above set forth, of a horizontal guard which prevents the types from falling on their flat while advancing upon the type platform. In this system of type distribution, the types, &c., are necessarily arranged upon their edges in their containing channels and would therefore be liable to turn upon their longitudinal axes upon leaving the control of the side walls of their containing channels. Should this occur,—one or more of the thinner types or a space falling upon "the flat,"—the types would clog as they advanced and the time lost in re-arranging the types, &c., would render the device of little practical value. The importance of the guard in insuring the effective action of the concave pusher and converging guide walls is thus obvious.

Our invention includes certain minor fea-

tures of construction, one consisting in forming the type forwarder device with a finger hook by means of which the second finger of the hand may be utilized in pulling the type forwarder forward, thereby leaving the thumb and index finger free to grasp and firmly hold the types previously advanced. We do not however limit ourselves to the use of a type forwarder to be operated directly by hand, since the essential features of our invention may be utilized in conjunction with other forms of type separating and forwarding apparatus. Neither do we confine ourselves to the identical form of parts shown, since it is obvious that various modifications may be made in construction and arrangement without departing from the spirit and intent of our invention.

In the accompanying drawings, Figure 1, is a side elevation of an arrangement of parts embodying our invention, the type forwarder being represented as pulled out and having forwarded the next succeeding types into position to be grasped between the thumb and fingers of the compositor when he again starts to pull the type forwarder out. Fig. 2, is a side elevation of the type forwarder removed. Fig. 3, is a top view of the same. Fig. 4, is a horizontal section upon plane of line *u, u*, Fig. 1, showing a plan of the type platform, &c., with the pusher removed. Fig. 5, is a horizontal section upon plane of line *w, w*, Fig. 1, showing the type forwarder in its retracted position, with the types last forwarded into position upon the front of the platform. Fig. 6, is a horizontal section upon plane of line *v, v*, Fig. 1, showing the type forwarder partially advanced,—the heels of the types just leaving the channels; Fig. 7, a similar view, with the type forwarder still further advanced. Fig. 8, is a front elevation, with the front plate removed. Fig. 9, is a front view, with the front plate in position. Fig. 10, is an elevation of the front plate. Fig. 11, is a side elevation of the parts with the type forwarder in its retracted position. Fig. 12, is a central vertical section on plane of line *x, x*, Fig. 5. Fig. 13, is a vertical section upon plane of line *y, y*, Fig. 11. Fig. 14, is a vertical section upon plane of line *z, z*, Fig. 11; Fig. 15, a vertical section upon plane of line *1, 1*, Fig. 11; Fig. 16, a horizontal section upon an enlarged scale, upon plane of line *v, v*, Fig. 1, certain of the parts being broken away. Fig. 17, is a vertical section upon plane of line *2, 2*, Fig. 16. Fig. 18, is a side elevation of the adjustable partition removed. Fig. 19, is a top view of same.

The socket piece or support A, for the type containing channels B, may be of any convenient or desired construction, the only essential being the provision of means for supporting the type channels B, above the type supporting platform *a*. As shown in the drawings the platform *a*, is formed in one piece with the holder A, a slot *a*², in the rear wall *a*¹, (shown in Figs. 12 and 14) admitting

the pusher blade *c*. This pusher blade *c*, is supported at the rear upon a slide C, resting upon the support D, upon which it is confined by the inner edges *e, e*, of the plates E, between the rear extremities of which the pulley *e*¹, is mounted. The plates E, are secured between the type platform *a*, of the holder A, and the support D, thus forming a groove *d*, in which the slide C, reciprocates.

The forward end of the slide C, is formed with a finger piece *c*¹, which may vary in construction. It may be simply formed with concavities *c*², *c*², on either side, as will be seen in Figs. 3, 5, 6 and 7, in which case it is grasped between the finger and thumb of the compositor as he simultaneously grasps the types last advanced upon the type platform (see position of parts shown in Fig. 5); or a downwardly projecting trigger piece *c*³, is formed upon it, which affords a bearing for the second finger of the hand of the compositor, leaving his thumb and index finger free above to grasp and hold the types. We prefer however to form the finger piece *c*¹, with both the concavities *c*², *c*², and the trigger piece *c*³, as they harmonize and may be used advantageously together.

The slide C, as a whole is held in its normal position by means of a cord and weight *c*⁴, *c*⁵, or by other suitable means for effecting a retractile movement of the pusher blade *c*.

The lower extremities of the type containing channels B, are shown as supported in the holder A, upon shoulders *a*¹¹, *a*¹¹, which are equal in width to the thickness of the side walls of the channels. Thus a continuous vertical passage is formed for the types, the lowest of which in each column rests upon the type supporting platform *a*. The types are arranged in their channels upon their edges, faces outward, and all but the lowest are retained in position by a front plate F, sliding in vertical grooves *a, a*, in the side walls of the holder A. The side walls of the holder are formed with parallel extensions *a*²¹, *a*²¹, upon the type platform *a*. These extensions are approximately about as high as the average width of types in the different fonts of types to be used. At the forward end of these extensions *a*²¹, *a*²¹, are formed converging guide walls G, G, which contract the space upon the type platform *a*, to a port *g*, little exceeding in width the combined thickness of the types to be simultaneously detached and forwarded.

The forward movement of the pusher blade *c*, is limited by reason of the shoulder *c*⁴¹, coming in contact with the rear projection *a*³, of the holder A, or by equivalent means; while in its normal position it is held by the weight *c*⁵, or other retracting device, with the shoulder *c*⁶, of its finger piece *c*¹, resting against the front edge of the type platform *a*. In this latter position the types last forwarded project over the top of the finger piece *c*¹, as shown in Figs. 5 and 11.

The converging guide walls G, G, are pref-

erably though not necessarily, made adjustable, for the purpose of regulating the width of the port *g*, to the requirements of the type in use. This may be accomplished by any suitable or well known means. As shown in the drawings, the screws *g'*, *g'*, upon which the converging walls turn, may be utilized as set screws to clamp the said walls to the top of the type platform *a*, at any suitable angle with relation to each other. Straddling the parallel extensions *a*²¹, *a*²¹, is a top guard *H*, the under side of which is above the surface of the type platform *a*, a distance barely exceeding the width of the types in use. Before the types clear their channels they are well under this guard *H*, which then prevents their turning upon their longitudinal axes during the completion of their advance. The projection of the heads of the types through the port *g*, also prevents any such movement of the types when beyond the control of the guard *H*.

The guard *H*, is made adjustable, to conform to variations in the widths of types of different fonts, by any convenient means. In the drawings, the flanges *h*, *h*, are formed with vertical slots *h'*, *h'*, through which pass the set screws *h*², *h*², by which means the guard *H*, may be adjusted vertically within certain limits.

Where it is designed to cut off one or more types and channels from the combination we provide the guard *H*, with a movable partition *I*, similar to that shown in Figs. 16, 17, 18 and 19. This partition *I*, is adjustable both laterally across the guard and in inclination with relation thereto also. This adjustment is effected in the drawings by a single screw and thumb nut *i*,—the screw being cut upon the upper end of the stud *i'*, projecting from the top of the partition *I*, as will be seen by reference to Fig. 18,—said stud passing through the longitudinal slot *h*³, formed in the guard *H*, so as to draw up the partition *I*, against the under side of the guard when the nut *i*, is tightened. In Figs. 16 and 17, the partition, *I*, is shown as adjusted to cut off the right hand channel, or in other words to contract the space upon the type platform to the requirements of the three other channels in use,—the types being absent from the right hand channel, as otherwise they would continue to be forwarded by the pusher, which latter passes under the partition *I*, as will be seen by reference to Fig. 17. The pusher is comparatively thin, so that the partition can be made of ample depth to guide the types without interfering with the pushing blade.

The front edge of the pusher blade *c*, is preferably made concave, more or less, as will be seen by reference to Figs. 3, 6, 7 and 16. The result of this is that the types, as they move forward under the influence of the pusher, tend constantly to conform at their heels to the curvature of the pushing edge,

and as they leave their retaining columns they assume radial positions with relation to the concave edge, as illustrated in Fig. 6.

What we claim as our invention, and desire to secure by Letters Patent, is—

1. In type setting apparatus, the combination of a plurality of type containing channels, a type platform common to all the types, and a type-forwarder formed with a concave edge for bearing against the heels of the types, substantially in the manner and for the purpose set forth.

2. In type setting apparatus the combination of a plurality of type containing channels, a type platform common to all the types, a type forwarder, and converging guide walls upon the said type platform arranged and operating substantially in the manner and for the purpose described.

3. In type setting apparatus the combination of a plurality of type containing channels, a type platform common to all the types, converging guide walls upon said type platform, a type forwarder, and means for adjusting the said converging guide walls with relation to each other, substantially in the manner and for the purpose described.

4. In type setting apparatus, the combination of a plurality of type containing channels, a type platform common to all the types, converging guide walls upon said type platform, and a type forwarder formed with a concave edge for contact with the heels of the types substantially in the manner and for the purpose described.

5. In type setting apparatus the combination of a plurality of type containing channels, a type platform common to all the types, converging guide walls on said type platform, a type forwarder, and a horizontal guard over the type platform arranged to prevent the types from turning upon their longitudinal axes, substantially in the manner and for the purpose described.

6. In type setting apparatus the combination of a plurality of type containing channels, a type platform common to all the types, converging guide walls on said type platform, a type forwarder, a horizontal guard over the type platform, and an adjustable partition upon said type guard for the purpose and substantially in the manner described.

7. In type setting apparatus the combination of a plurality of type containing channels, a type platform common to all the types, converging guide walls on said type platform, and a type forwarder consisting of a finger pull formed with a type blade substantially in the manner and for the purpose described.

8. In type setting apparatus the combination of a plurality of type containing channels, a type platform common to all the types, converging guide walls upon the said type platform, a type forwarder consisting of a finger pull formed with a type blade, and means for retracting the said type forwarder

automatically to its normal position, substantially in the manner and for the purpose described.

5 9. In type setting apparatus the combination of a plurality of type containing channels, a type platform common to all the types, converging guide walls upon said type platform, a type forwarder formed with a finger pull having a trigger handle, and means for

retracting the said type forwarder to its normal position, substantially in the manner and for the purpose described.

LOUIS K. JOHNSON.
ABBOT A. LOW.

Witnesses:

GEORGE WILLIAM MIATT,
D. W. GARDNER.