

No. 624,947.

Patented May 16, 1899.

D. KREKES.
PADLOCK.

(Application filed Dec. 31, 1897.)

(No Model.)

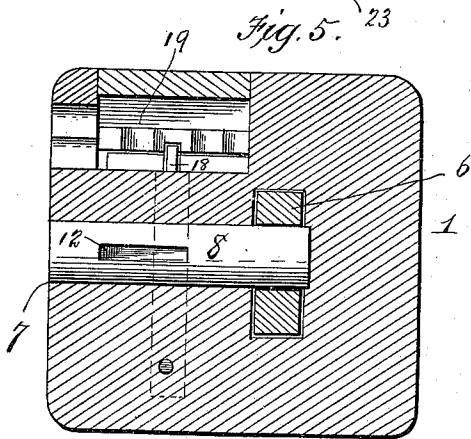
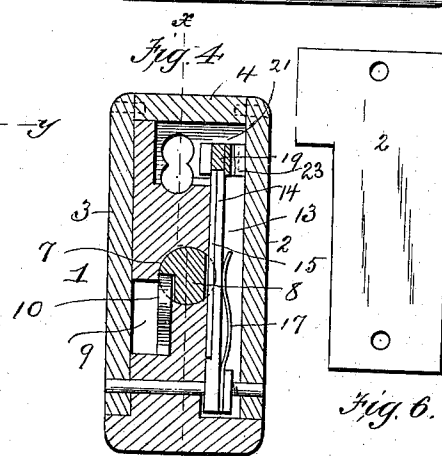
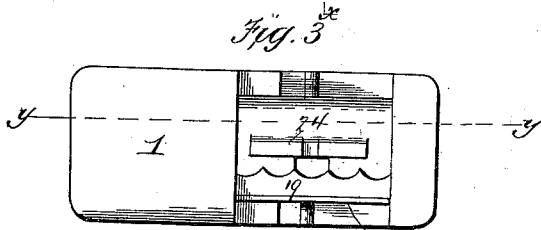
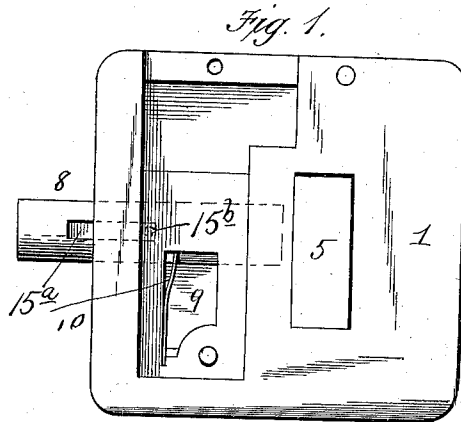
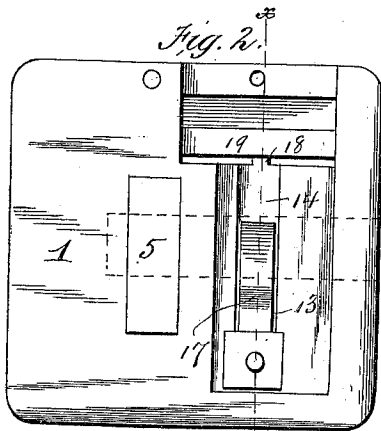

Fig. 6.

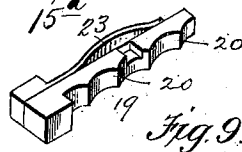
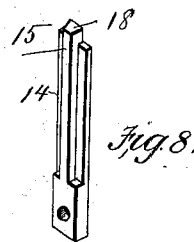
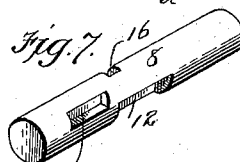
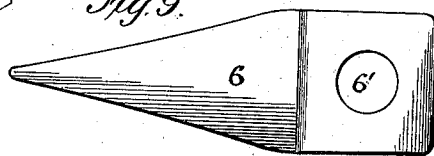
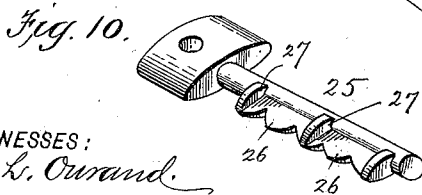

Fig. 11.



WITNESSES:
Frauck L. Curand.
Jo. L. Leonards

INVENTOR
Daniel Krekes.
 BY *O. D. Lewis*

His ATTORNEY.

UNITED STATES PATENT OFFICE.

DANIEL KREKES, OF PITTSBURG, PENNSYLVANIA, ASSIGNOR OF ONE-HALF
TO CAROLINE FEKETE, OF SAME PLACE.

PADLOCK.

SPECIFICATION forming part of Letters Patent No. 624,947, dated May 16, 1899.

Application filed December 31, 1897. Serial No. 664,880. (No model.)

To all whom it may concern:

Be it known that I, DANIEL KREKES, a citizen of Hungary, residing at Pittsburg, in the county of Allegheny and State of Pennsylvania, have invented certain new and useful Improvements in Padlocks; and I do declare the following to be a full, clear, and exact description of the invention, such as will enable others skilled in the art to which it appertains to make and use the same, reference being had to the accompanying drawings, and to the figures of reference marked thereon, which form a part of this specification.

My invention relates to hasp-locks which are secured to the free end of a hasp, the other end of which is hinged to a door or other object.

The object of the invention is to provide an improved lock which shall possess superior advantages with respect to efficiency in use.

The invention consists in the novel construction and combination of parts hereinafter fully described and claimed.

In the accompanying drawings, Figure 1 is a side elevation of a lock constructed in accordance with my invention, partly broken away and showing the bolt retracted. Fig. 2 is a similar view looking from the opposite side, the bolt being shot. Fig. 3 is a plan view. Fig. 4 is a section on the line $x x$ of Fig. 2. Fig. 5 is a longitudinal section on the line $y y$ of Fig. 3. Fig. 6 is an elevation of one of the removable side plates. Fig. 7 is a perspective view of the bolt. Fig. 8 is a similar view of the retaining-arm. Fig. 9 is a perspective view of the ward-plate. Fig. 10 is a perspective view of the key. Fig. 11 is a detail view of the staple.

In the said drawings the reference-numeral 1 designates the lock-casing, consisting of a rectangular casing provided with removable side plates 2 and 3 and a top plate 4. Near one end said casing is formed with a rectangular transverse hole 5 for the passage of a staple 6. Intersecting with this hole is a horizontal bore 7 to receive the bolt 8. Located in a recess 9, in one side of the lock-casing, is a spring 10, the free end of which engages with a notch 12 in said bolt and which serves to retract the bolt. Said recess is closed by

the side plate 3. In the opposite side said casing is formed with a recess 13, in which is located a retaining-bar 14, the lower end of which is pivoted to said casing. Upon its inner side said bar is provided with a vertical rib 15, which engages with a slot 16 in the bolt and holds the latter in a locked position. There is a notch 15^a formed in the bolt, with which is adapted to engage a projection 15^b (see Fig. 1) for preventing the bolt from turning. A spring 17 presses said bar into engagement with the slot, and the upper end of the bar is formed with a lug 18. The recess 13 is closed by the side plate 2.

The numeral 19 designates a movable ward-plate formed with a number of wards 20. This plate rests loosely in a recess 21 in the upper part of the lock-casing and is pressed inwardly by means of a spring 23. A projection 24 limits the inward movement of said ward-plate.

The numeral 25 designates the key, provided with a number of bits 26 and with beveled projections 27.

The operation of my improved lock is as follows: The lock is secured to the free end of a hasp and in its normal or unlocked position is retracted by the spring. When in use, the hasp is closed over the staple 6, which is formed with a hole 6', which coincides with the bolt, the staple passing through the hole 5. The end of the bolt projecting beyond the casing is now pressed inward, forcing the inner end of the same through the hole in the staple. The retaining-bar will now engage with the slot in the bolt, holding the bolt in its locked position. The ward-plate will now be pressed inwardly by the spring 23, so as to lie over the upper end of the retaining-bar. To unlock the lock, the key is passed through the keyhole and turned so that the bits will engage with the wards of the ward-plate, pushing the latter outwardly. The central projection of the key will now strike the lug at the upper end of the retaining-bar, throwing it outwardly and disengaging it from the slot in the bolt, when the latter will be retracted by the spring.

Having thus fully described my invention, what I claim is—

In a padlock, the combination with the casing formed with a transverse hole and an intersecting longitudinal bore, the bolt formed with a peripheral slot and an opposite notch, of the retracting-spring engaging with said notch, the spring-actuated retaining-bar having a rib engaging with said slot, the loose ward-plate provided with a number of wards, and the spring pressing said ward-plate over

the upper end of the retaining-bar, substantially as described.

In testimony whereof I affix my signature in presence of two witnesses.

DANIEL KREKES.

Witnesses:

JAS. J. MCAFEE,
GEORGE GRIEN.