

(12) UK Patent Application (19) GB (11) 2 365 497 (13) A

(43) Date of A Publication 20.02.2002

(21) Application No 0019343.3

(22) Date of Filing 08.08.2000

(71) Applicant(s)  
Rolls-Royce plc  
(Incorporated in the United Kingdom)  
65 Buckingham Gate, LONDON, SW1E 6AT,  
United Kingdom

(72) Inventor(s)  
Geoffrey Mathew Dailey

(74) Agent and/or Address for Service  
M A Gunn  
Rolls-Royce plc, Patents Department, PO Box 31,  
Moor Lane, DERBY, DE24 8BJ, United Kingdom

(51) INT CL<sup>7</sup>  
F01D 5/18

(52) UK CL (Edition T )  
F1V VCAA V106 V111 V414 V420  
U1S S1987

(56) Documents Cited  
GB 2184492 A GB 1537447 A  
GB 1530256 A US 5914060 A  
US 4257737 A

(58) Field of Search  
UK CL (Edition R ) F1V VCAA  
INT CL<sup>7</sup> F01D 5/00 5/12 5/14 5/18 9/00 9/02  
ONLINE: EPODOC, JAPIO, WPI

(54) Abstract Title  
Gas turbine aerofoil cooling with pressure attenuation chambers

(57) A gas turbine engine aerofoil 24 has a plurality of attenuation chambers 34 positioned between a cooling air passageway 26 and its leading edge 28. Cooling air passing from the passageway 26 to the exterior surface of the leading edge is attenuated in pressure by impingement on the opposing walls of the respective chambers 34, prior to leaving the chambers 34 via exit passageways 38 which straddle the leading edge. A plurality of input passageways 36 are provided for flow from passageway 26 into the chambers 34, and each chamber may have numerically less input passageways 36 than exit passageways 38. In alternative embodiments, passageways (36, fig 5) connect to upper and/or lower ends of each chamber 36 for pressure attenuation resulting from expansion therein. Hot spots due to blockage and effects due to pressure fluctuation are reduced.

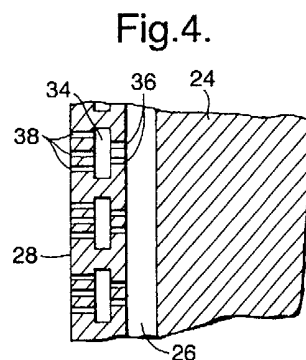
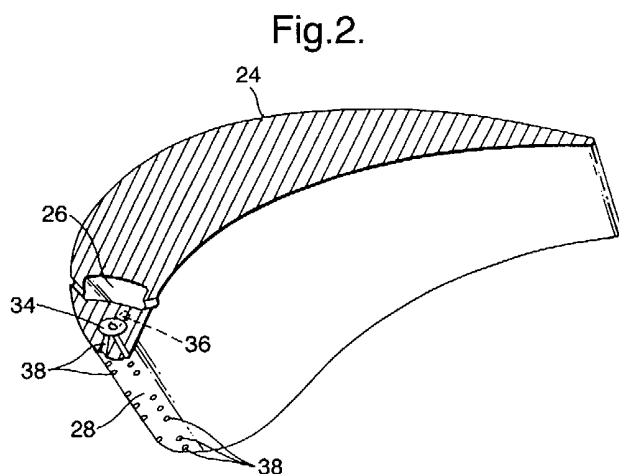

Fig. 1.

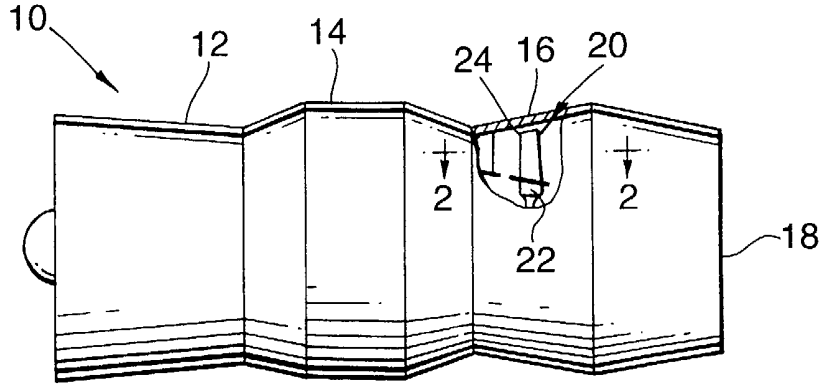

Fig. 2.

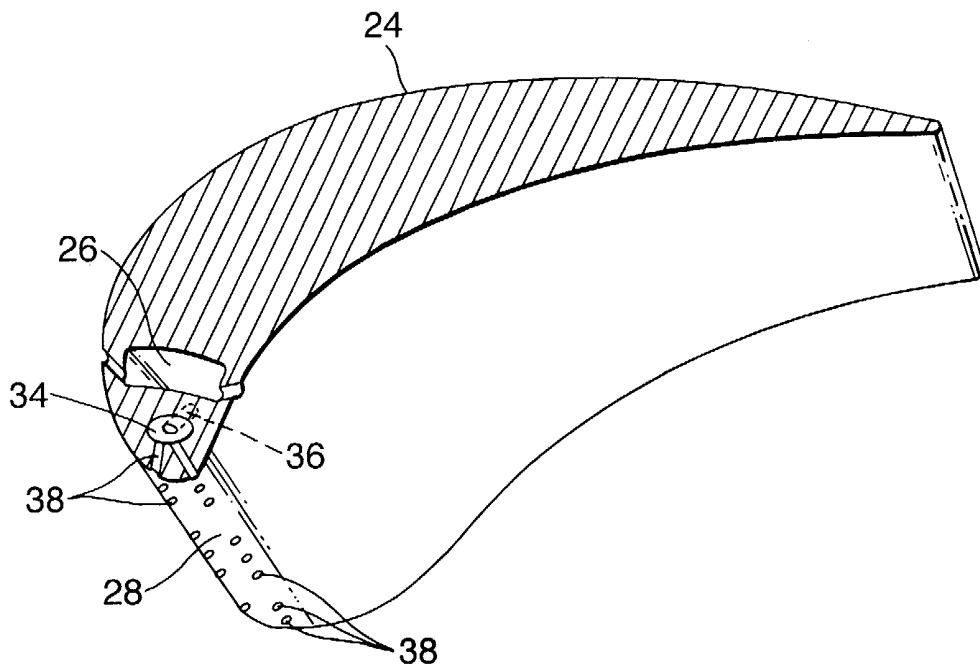

Fig.3.

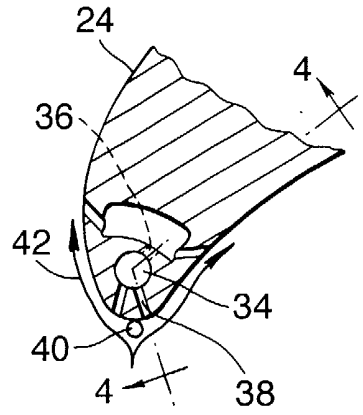

Fig.4.

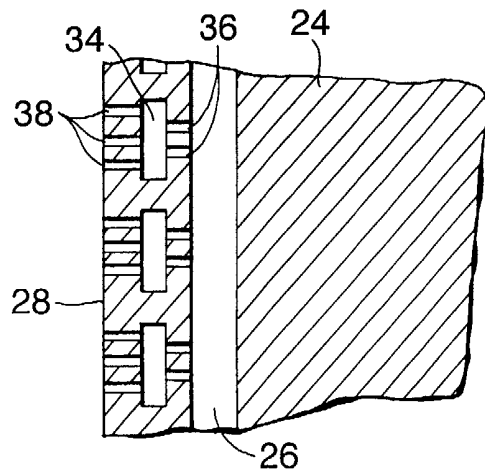
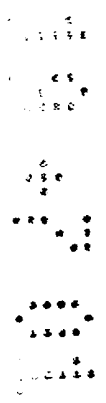
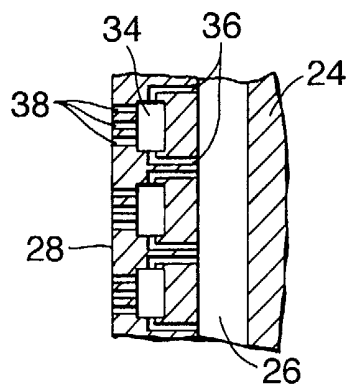

Fig.5.



IMPROVED COOLED GAS TURBINE AEROFOIL

The present invention relates to aerofoils of the kind used in gas turbine engines. In particular, though not  
5 restrictively so, the present invention relates to aerofoils that are mounted on a turbine disc, for rotation in the turbine section of a gas turbine engine, so as to achieve driving rotation of an associated compressor shaft in known manner.

10 It is the accepted practice to pass a flow of air from a compressor of a gas turbine engine through passageways provided in the aerofoil for that purpose, so as to cool the aerofoil. This enables its use in temperatures higher than would otherwise be possible,  
15 having regard to the relevant characteristics of the material from which the aerofoil is made. Known arrangements include the provision of an aforementioned passageway through the radial length of the aerofoil, with respect to its axis of rotation during operation. The  
20 passageway is connected to the exterior surface of the aerofoil in the region of its leading edge, by a plurality of much smaller passageways, through which the cooling air flows, to film cool the said exterior surface.

An alternative arrangement provides a second  
25 passageway that also extends radially lengthwise of the blade interior, in parallel with an aforementioned passageway, and is connected thereto via a plurality of much smaller passageways. The second passageway is also connected to the exterior surface of the aerofoil in the  
30 region of its leading edge, by a plurality of much smaller passageways, the respective positions of which are staggered relative to the positions of the first mentioned small passageways. The arrangement results in impingement cooling of the interior surface of the second passageway by

air flowing from the aforementioned passageway via the smaller passageways therebetween, followed by film cooling of the exterior surface of the aerofoil in the region of its leading edge by the same airflow, when it exits the  
5 small passageways that connect the second passageway therewith, having negotiated the staggered flowpath.

The prior art modes of cooling a turbine blade aerofoil as described hereinbefore, are unable to limit or counter the adverse affects they experience, due to  
10 pressure fluctuations which occur during operation of an associated gas turbine engine, or due to blockage of one or more of the small passageways connecting the second passageway to the exterior surface of the aerofoil. For example, should engine pressure rise excessively, the  
15 resulting rise in cooling air flow pressure within the aerofoil will result in an increase in the exit velocity of air into the gas stream, along the whole length of the aerofoil, which in turn, could have an adverse affect on the gas stream flowing along the flanks of the aerofoil.  
20 Should engine pressure fall excessively, the resulting pressure drop in the passageways could enable the hot gas flow to overcome the cooling airflow and enter the interior of the aerofoil.

When cooling air exit holes become blocked, a small  
25 pressure rise occurs in the aforementioned and second passageways. However, as the pressure rise occurs over the total volume of the two major passageways, it has little affect , if any, on the flow of air from the aerofoil. It follows, that hot spots could develop on the leading edge  
30 of the aerofoil, in the region of the blockage.

The present invention seeks to provide an improved cooled gas turbine engine aerofoil.

According to the present invention, a gas turbine engine aerofoil includes a cooling air passageway which

extends from the root thereof to a position adjacent its tip, and a plurality of chambers, spaced from said passageway, in a portion of said aerofoil between its leading edge and said passageway, each said chamber being  
5 connected to said passageway and to the exterior surface of said aerofoil leading edge by respective pluralities of further passageways.

The invention will now be described, by way of example and with reference to the accompanying drawings, in which:

10 Fig.1 is a diagrammatic view of a gas turbine engine including turbine aerofoils in accordance with the present invention.

Fig.2 is a pictorial part view of the aerofoil of Fig.1

15 Fig.3 is a cross sectional part view on line 2-2 in Fig.1.

Fig.4 is a cross sectional part view on line 4-4 in Fig. 3.

Fig.5 is a variant of the example of Fig.4.

20 Referring to Fig.1. A gas turbine engine 10 has a compressor 12, combustion equipment 14, a turbine section 16, and an exhaust nozzle 18. The turbine section 16 has a stage of turbine blades 20 mounted via respective roots 22, onto a disc (not shown) in known manner. Each blade 20  
25 includes an aerofoil 24 over which, during operation of the engine 10, hot gases from the combustion equipment flow, again in known manner.

Referring now to Fig.2. Each aerofoil 24 has a passageway 26 formed therein, which extends from the  
30 aerofoil root to a position near its tip, the root end of the passageway being connected (not shown) to receive a flow of cooling air from the compressor 12. Passageway 26 is positioned closer to the leading edge 28 of aerofoil 24 than the trailing edge 30 thereof, and is parallel thereto.

That portion of the aerofoil which lies between passageway 26 and the aerofoil leading edge 32 contains a number of radially spaced apart elongate chambers 34, which are arranged with their major sides in parallel with passageway 26. Chambers 34 are best seen in Fig.4.

Each chamber 34 is in cooling flow connection with passageway 26 via a plurality of smaller passageways 36, and with the exterior of aerofoil 24 via further pluralities of smaller passageways 38.

The input passageways 36 into each chamber 34 are offset with respect to the output passageways 38, which will cause impingement of cooling air from passageways 36 on the facing wall surface of respective chambers 34, and thereby, attenuation of pressure and flow velocity of the cooling air, prior to its exit via passageways 38 to the exterior of the aerofoil 24. In the example, passageways 36, per chamber 34, are less in number than passageways 38. The criterion for deciding the relative numbers and sizes of passageways 36 and 38 however, is the essential need to achieve cooling air flow pressures in the chambers 34, over all operating conditions of the associated engine 10, which will avoid a reversal in pressure differentials between the cooling air within the chambers 34, and the external gas flow, which, if it occurred, would result in hot gases entering the aerofoil 24.

Referring to Fig.3. Cooling air exits aerofoil 24 via passageways 38, at positions which closely straddle a portion of the leading edge thereof, which portion extends the full length of the leading edge and over which, a stagnant layer of gas 40 is present, having been formed when the gas stream 42 parts, and flows each side of the aerofoil 24. The cooling air is then entrained by the gas flow, and flows therewith along the respective suction and pressure surfaces of the aerofoil 24.

Referring briefly to Fig.4. As stated hereinbefore, each chamber 34 of the present example has fewer input passageways 36 i.e. two, connecting it to passageway 26, than output passageways 38 i.e. six, connecting it to the exterior of the aerofoil 24, though only three are shown, in compliance with line 4-4 in Fig.3.

In Fig.5, passageways 36 connect with their respective chambers 34 at their upper and lower ends, but could be arranged so as to connect at one end only of each respective chamber 36.

A number of advantages not enjoyed by known prior art accrue from the aerofoil cooling air flow arrangement described and illustrated in this specification, and are listed hereafter.

- 15 a) Each chamber 34 exhausts to only a small range of external pressures, which enables its pressure differential relative thereto to be set closer to those pressures.
- b) The impingement of cooling air from passageway 26 onto the opposing walls of each chamber 34 attenuates pressure differential fluctuation, which occurs when cooling air pressures vary in passageway 26, as a result of variations in operating conditions of engine 10.
- 20 c) The impingement of cooling air from passageway 26 onto the opposing walls of each chamber 34 also attenuates the affects of flow fluctuations brought about by variations in the size passageways 36, which variations result from manufacturing tolerances. Where, as in Fig.5, impingement may not occur, the expansion of the cooling air into the chambers 34 will still achieve the desired flow and pressure attenuation, with their attendant advantages.
- 25 d) If cooling air exit passageways 38 in any chamber 34 are blocked by solids in the flow, pressure in that chamber will rise and attempt to maintain the cooling airflow.
- 30



e) The heat transfer coefficient is greater than has been achieved by systems not using impingement prior to ejection of the cooling air to the aerofoil exterior.

f) The present invention lends itself to the use of  
5 passageways 38 arranged in the form of a matrix, wherein  
each pair of passageways 38 overlap each other and  
intersect at their crossing points. By this means, their  
exit ends may be brought closer together than is indicated  
in Figures 2 and 3. Moreover, their flow requirements would  
10 not be excessive.

## CLAIMS

1. A gas turbine engine aerofoil including a cooling air passageway which extends from the root thereof to a position adjacent its tip, and a plurality of chambers spaced from said passageway, in a portion of said aerofoil between its leading edge and said passageway, each said chamber being connected to said passageway and to the exterior surface of the leading edge of said aerofoil by respective pluralities of further passageways.

2. A gas turbine engine aerofoil as claimed in claim 1 wherein each of said chambers is generally parallel with said cooling air passageway.

3. A gas turbine engine aerofoil as claimed in claim 1 or claim 2 wherein said respective pluralities of further passageways are offset with respect to each other.

4. A gas turbine engine aerofoil as claimed in any one preceding claim wherein each chamber has a greater number of cooling air exit passageways than cooling air input passageways.

5. A gas turbine engine aerofoil as claimed in any one preceding claim wherein the cooling air input passageways are generally parallel with the cooling air outlet passageways.

6. A gas turbine engine aerofoil as claimed in any of claims 1 to 4 wherein the cooling air input passageways are positioned at some angle other than parallel with respect to the cooling air passageways.

7. A gas turbine engine aerofoil substantially as described in this specification and with reference to each or any of the accompanying drawings.

8. A gas turbine engine including a turbine stage comprising an aerofoil as claimed in any previous claim in this specification.



INVESTOR IN PEOPLE

Application No: GB 0019343.3  
Claims searched: 1-6

Examiner: Terence Newhouse  
Date of search: 29 November 2000

### Patents Act 1977 Search Report under Section 17

#### Databases searched:

UK Patent Office collections, including GB, EP, WO & US patent specifications, in:  
UK CI (Ed.R): F1V(VCAA)  
Int CI (Ed.7): F01D 5/00 5/12 5/14 5/18 9/00 9/02  
Other: ONLINE: EPODOC, JAPIO, WPI

#### Documents considered to be relevant:

Category	Identity of document and relevant passage	Relevant to claims
A	GB 2184492 A (UNITED), see fig 1 noting plurality of chambers in leading edge	1 at least
X	GB 1537447 A (UNITED), see particularly page 3 lines 74-94 and figs 1 & 3 noting plurality of chambers in leading edge and exit passageways 34	
A	GB 1530256 A (ROLLS), see figs 2 & 3	1 at least
X	US 5914060 (UNITED), see figs 1, 2 & 4 noting inlet passageways 56,56a and exit passageways 42,42a	
A	US 4257737 (UNITED), see figs 1 & 2	

X	Document indicating lack of novelty or inventive step	A	Document indicating technological background and/or state of the art.
Y	Document indicating lack of inventive step if combined with one or more other documents of same category.	P	Document published on or after the declared priority date but before the filing date of this invention.
&	Member of the same patent family	E	Patent document published on or after, but with priority date earlier than, the filing date of this application.