

W. E. SNEDIKER.
Liquid Meter.

2 Sheets—Sheet 1.

No. 108,842.

Patented Nov. 1. 1870.

Fig. 1.

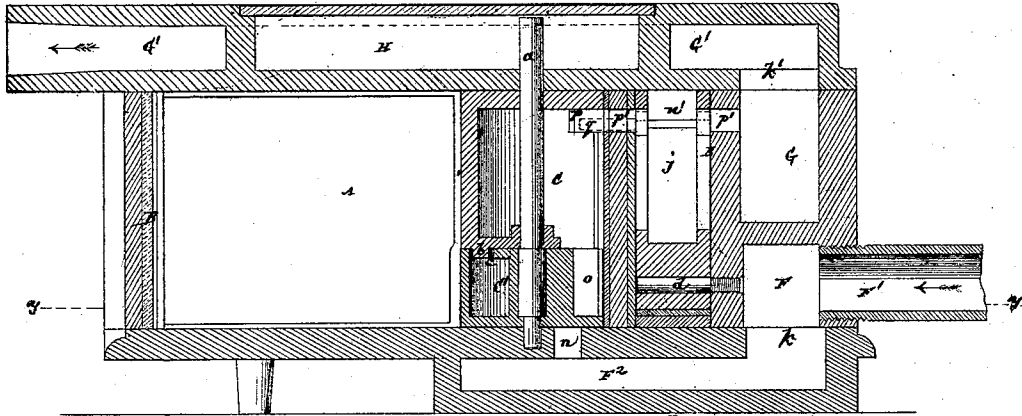
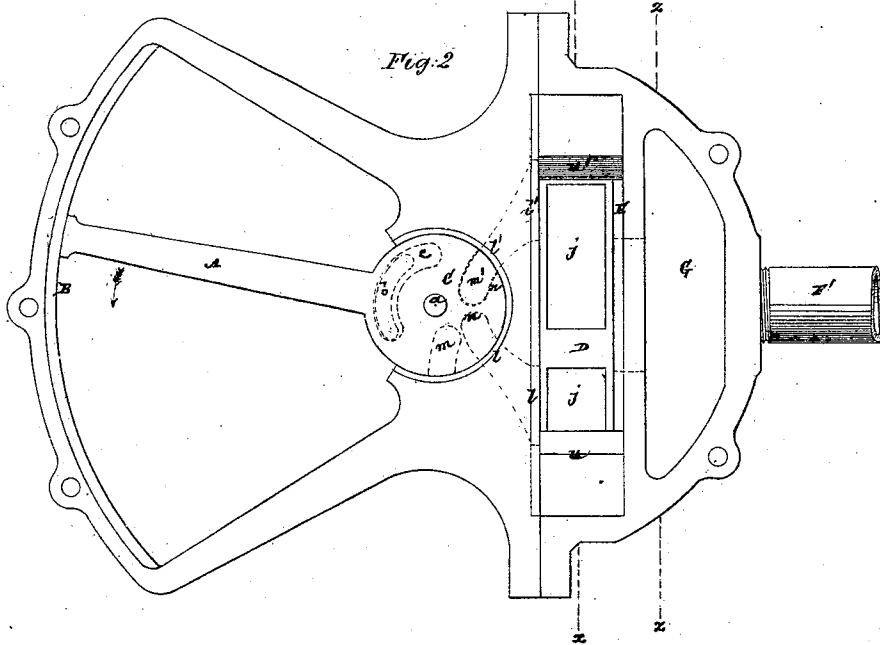

Fig. 2.



Witnesses:

Fred. Hays
R. H. Hays

W. E. Snediker

W. E. SNEDIKER.
Liquid Meter.

No. 108,842.

Patented Nov. 1. 1870.

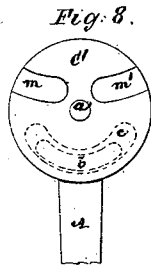
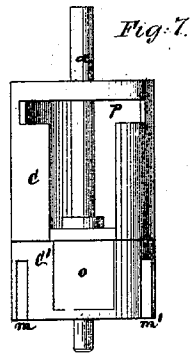
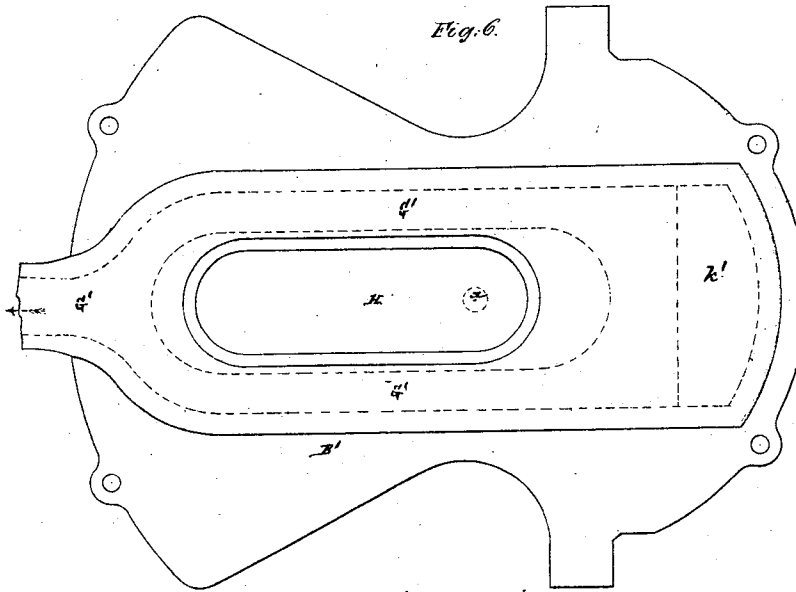

Witnesses:
Fred. Haynes
R. R. Kabaau

W. E. Snediker

United States Patent Office.

WILLIAM E. SNEDIKER, OF NEW YORK, N. Y.

Letters Patent No. 108,842, dated November 1, 1870; antedated October 29, 1870.

IMPROVEMENT IN LIQUID-METERS.

The Schedule referred to in these Letters Patent and making part of the same.

To all whom it may concern:

Be it known that I, WILLIAM E. SNEDIKER, of the city, county, and State of New York, have invented a new and useful Improvement in Liquid-Meters, of which the following is a full, clear, and exact description, reference being had to the accompanying drawing forming a part of this specification, and in which—

Figure 1 represents a vertical longitudinal section of a meter constructed in accordance with my improvement;

Figure 2, a plan of the same, with the lid or cover removed;

Figure 3, a transverse section, taken as indicated by the line *x x* in fig. 2;

Figure 4, a horizontal section, taken as denoted by the line *y y* in figs. 1 and 3, with the piston and main valve removed;

Figure 5, a transverse section through the line *z z* in figs. 2 and 4;

Figure 6, a plan of the lid or cover of the meter, detached;

Figure 7, a vertical view of the hub of the lever, diaphragm or piston; and

Figure 8, an inverted plan or bottom-end view of the same.

Similar letters of reference indicate corresponding parts.

The meter, which is the subject of this invention, while applicable to measuring various liquids or fluids, it will suffice here to describe as used for the measuring of water. The same is of a pendulum form of construction, and includes a reciprocating lever-diaphragm or piston, arranged to work within a measuring-chamber, of arched or sector-like form, and provided with a hub that has connected with it a pivot-pin, which constitutes the turning-axis or center of the lever-piston.

The principle feature of the improvement consists in a combination, with this reciprocating diaphragm or lever-piston, of a controlling-valve to the main valve, said controlling-valve being operated by the piston, and serving to establish a rush of the water or operating liquid on the main valve, to throw the latter, which main valve controls ingress and egress of said liquid, to and from the measuring-chamber. These valves may be of any suitable form, straight or curved, and be variously arranged; but it is preferred to construct the valve, which controls the main valve in the hub of the lever-piston, by making said hub of a valvular character; and

The invention includes a divided construction of said hub, whereby the valvular portion of it is allowed to remain stationary for a portion of the stroke of the lever-piston, so that the passages which control the flow of the water in throwing the main valve are

kept open the requisite length of time to secure a perfect action alike of the main valve and lever-piston.

Also, the invention embraces an arrangement of passages for establishing escape of water remaining in the valve-box toward the completion of the main valve's stroke, after said valve has closed the port which provides for escape of the main body of water used in throwing such valve.

Likewise, the invention includes a specific and advantageous combination or arrangement of passages in a meter, constructed to operate as described.

In the accompanying drawing—

A represents the reciprocating lever-diaphragm or piston of the meter, the same being arranged to work within a measuring-chamber, B, of arched or sector-like form.

This diaphragm is provided with a hub, C C', through which is a pivot-pin, *a*, that constitutes the working axis or center of said diaphragm or lever-piston, and which is here shown as occupying a vertical position, but which may be horizontal, and the lever-piston have an action or stroke similar to that of a pendulum. This hub C C' is formed hollow, but generally closed at its ends, the lower one of which rests on and travels over the lower face of the chamber B. It is preferably made in two, or upper and lower sections, C C', the lower one C', being fast to the pivot *a*, and only being moved toward the completion of the stroke of the lever-piston, through an arched projection, *b*, on the base of the upper section C, (which is loose on the pivot, but fast to the lever-diaphragm,) coming in contact with either end, alternately, of a curved slot, *c*, in the top plate or face of the lower section C' of the hub, said curved slot *c* being longer than the arched projection *b*, so that the lever-piston, with its hub-section C, will perform a certain amount of reciprocating stroke in either direction before shifting the lower hub-section C'. The object of thus dividing the hub, and making the one section, C, act as an intermittent driver to the other section, C', that has a valvular action, as hereinafter explained, will be made clear in due course of the general description.

The motion of the lever-piston A, that receives and discharges water from opposite sides of it alternately, is controlled by a valve, D, which is preferably of curvilinear form, vibrating on a lower horizontal center, *d*, within a valve-box or case, E, against both inner sides or faces of which said valve moves in contact, to control ports or passages therein.

Two of these ports, *e e'*, in the front surface, against which the valve works, are main inlets to the measuring-chamber B, on opposite sides of the piston and other two ports *f f'*, in the same plane or surface, outlets therefrom, there being corresponding inlet and outlet-ports, *g g'* and *h h'*, in the back or opposite surface, against

which the valve works, which latter ports, $g' g'$ and $h' h'$, are in communication, respectively, with an inlet water-chamber, F , and outlet-water chamber G .

The valve D has main inlet-passages, $i' i'$, and a main outlet-passage or cavity, j , through it, which passages are brought, successively, by the tip or play of the valve, in line respectively with the fixed inlet and outlet-ports, $e' e'$, $f' f'$, $g' g'$, and $h' h'$, to pass water to and from opposite sides of the piston in the measuring-chamber B .

The inlet water-chamber F is supplied with water by a pipe, F^1 , and has an opening, k , in it, establishing communication with the lower chamber or passage, F^2 , arranged to extend beneath the measuring-chamber, immediately below the hub-piston, while the outlet-chamber G has an opening, k' , in it, establishing communication with an upper outlet-passage, G' , made in a raised portion of the lid B' of the measuring-chamber, and arranged to run along either side of a space or chamber, H , in which the indicating or registering mechanism, operated by the pivot-pin a , may be placed.

The front surface, against which the valve D works, has also arranged in it, below the inlets $e' e'$, ports or passages, $l' l'$, which run or project into the sides of the recess in which the hub of the piston works, and are of vertical elongated form at their openings into said recess.

The lower section C' of the hub plays over these passages, and, by means of vertical passages, $m' m'$, opening through the bottom of the hub, alternately establishes communication, through an arched port or ports, $n' n'$, in the base of the measuring-chamber, between either one of such passages $l' l'$, and the inlet water-chamber or passage F^2 , and exhaust-port o , that is in free connection with the hollow upper section C of the hub, being brought over or opposite either passage, l or l' , when either passage, m or m' , is in communication with the other of the passages $l' l'$.

In this way, accordingly as the hub-section C' is vibrated in opposite directions, is a rush of inlet-water induced through either of the passages $l' l'$, to complete the throw of the valve D , after the latter has been started by either end of an exhaust-port, p , in the upper section C of the hub acting, during the working of such hub-section, on a pin, q , arranged to project from the face of the valve.

The exhaust-port p also serves, in connection with ports $p' p'$, in the valve-chest, and the exhaust-passage j through the valve, to carry off the water used in the throw of the valve when the exhaust-port o of the hub is in suitable connection with either passage, l or l' , for such purpose.

As represented in the drawing, the valve D has been tipped, or, rather, the completion of its throw effected, by water entering through the passage l , the main body of water previously used in the throw of the valve in the reverse direction having been discharged through the passage l' , and up through the hub and ports and passages $p' p'$, and valve exhaust-cavity or passage j , into the outlet-chamber G .

By the valvular portion or section C' of the hub only having an intermittent movement toward the completion of the lever-piston's stroke, through gear

of the hub-sections $C' C'$, as hereinbefore described, the inlet-passages $m' m'$ and exhaust-port o in the hub-section C' are caused to remain a sufficient length of time in communication with either passage $l' l'$ and port or ports $n' n'$, to secure the full throw of the valve, and, by the controlling action of the latter over the main inlets $e' e'$ and main outlets $f' f'$ of the measuring-chamber, to secure the complete stroke of the lever-piston under all pressures of the incoming water.

To perfect the action, herein described, of the main valve D , which is only started in its throw by positive connection with, or action on it, of the lever-piston, and has its throw completed by a rush of inlet water, it is desirable or necessary to make some provision for getting rid of water that cannot escape through either of the passages, l or l' , open to the exhaust, by reason of said valve, toward the completion of its throw, covering such passage.

To this end the valve D has its exhaust-cavity or passage, j made to open through the top as well as through the sides of the valve, and said valve made to work on its periphery in contact with abutments $u' u'$, in such manner that, as the valve approaches the end of its throw in either direction, the exhaust-passage j is exposed beyond either abutment, u or u' , alternately, for escape to the exhaust, of remaining water used to effect the previous throw of the valve.

The starting of the main valve by a positive motion derived from the piston, may, in some cases, be dispensed with, and the whole throw of the same be effected by the operating liquid through the agency of a suitable secondary or additional valve operated by the lever-piston, the hub-section C' , in the construction and arrangement of parts represented in the drawing, constituting one form of such secondary or controlling-valve to the main valve.

What is here claimed, and desired to be secured by Letters Patent, is—

1. The combination, with a reciprocating lever-diaphragm or piston, and measuring-chamber in which it works, of a main valve to said chamber, and secondary or additional valve, operated by the lever-piston, and serving to effect the throw of the main valve by or through the operating liquid, essentially as herein set forth.

2. The hub of the lever-diaphragm, constructed of independent sections, $C' C'$, the one of which, C' , is made to operate as a valve, and has an intermittent motion communicated to it by the other section, C , essentially as and for the purpose herein set forth.

3. The valve D , provided with an exhaust-passage or opening in its periphery, in combination with the abutments $u' u'$, substantially as and for the purpose specified.

4. The arrangement, relatively to the valve D , of the ports or passages $l' l'$, the hub-ports or passages $m' m'$, and o , the inlet-port or ports $n' n'$, and exhaust-port or ports from the hub to the main outlet, essentially as described.

W. E. SNEDIKER.

Witnesses:

FRED. HAYNES,
HENRY PALMER.