



(72) MICSUNESCU, VICTOR, AU

(71) MICSUNESCU, VICTOR, AU

(51) Int.Cl.⁶ C05F 17/02, A01K 67/033, C05F 17/00

(30) 1997/04/04 (PO 6011) AU

(30) 1997/04/14 (PO 6173) AU

(54) **PROCEDE ET DISPOSITIF POUR RECYCLER DES DECHETS
ORGANIQUES**

(54) **A PROCESS AND APPARATUS FOR THE PRODUCTION OF
RECYCLED ORGANIC WASTE**

(57) Procédé permettant de produire un matériau recyclé à partir de déchets organiques, selon lequel on utilise lesdits déchets pour nourrir les vers de terre, de façon que ces derniers produisent le matériau recyclé sous forme d'éliminations. Les conditions d'alimentation des vers sont maintenues telles qu'au moins une partie de leurs éliminations se présente sous forme liquide. Les vers peuvent être maintenus à l'intérieur d'une cuve sensiblement close, dans un lit formé desdits déchets organiques et disposé dans ladite cuve. Le lit peut être constitué d'au moins une couche supérieure, ayant une profondeur comprise sensiblement entre 2 et 3 cm, et se trouver dans une atmosphère riche en oxygène. La cuve peut également comporter un système pour rassembler les éliminations liquides.

(57) A process for the production of recycled material from organic waste wherein the organic waste is used as feed for earthworms such that the recycled material is produced by the earthworms as castings, wherein the feeding conditions for the earthworms are maintained such that at least part of the castings is produced in liquid form. The earthworms can be maintained in a substantially closed vessel, in a bed of said organic waste in the vessel. The bed of organic waste may have at least an upper layer substantially in the range 2 to 3 centimetres in depth, and may be provided in an oxygen rich atmosphere. The vessel may also include means for collecting the liquid castings.

PCTWORLD INTELLECTUAL PROPERTY ORGANIZATION
International Bureau

INTERNATIONAL APPLICATION PUBLISHED UNDER THE PATENT COOPERATION TREATY (PCT)

(51) International Patent Classification ⁶ : C05F 17/02, 17/00, A01K 67/033	A1	(11) International Publication Number: WO 98/45229 (43) International Publication Date: 15 October 1998 (15.10.98)
(21) International Application Number: PCT/AU98/00221 (22) International Filing Date: 2 April 1998 (02.04.98) (30) Priority Data: PO 6011 4 April 1997 (04.04.97) AU PO 6173 14 April 1997 (14.04.97) AU (71)(72) Applicant and Inventor: MICSUNESCU, Victor [AU/AU]; 223 Canterbury Road, Forest Hills, VIC 3131 (AU). (74) Agents: LESLIE, Keith et al.; Davies Collison Cave, 1 Little Collins Street, Melbourne, VIC 3000 (AU).	(81) Designated States: AL, AM, AT, AU, AZ, BA, BB, BG, BR, BY, CA, CH, CN, CU, CZ, DE, DK, EE, ES, FI, GB, GE, GH, GM, GW, HU, ID, IL, IS, JP, KE, KG, KP, KR, KZ, LC, LK, LR, LS, LT, LU, LV, MD, MG, MK, MN, MW, MX, NO, NZ, PL, PT, RO, RU, SD, SE, SG, SI, SK, SL, TJ, TM, TR, TT, UA, UG, US, UZ, VN, YU, ZW, ARIPO patent (GH, GM, KE, LS, MW, SD, SZ, UG, ZW), Eurasian patent (AM, AZ, BY, KG, KZ, MD, RU, TJ, TM), European patent (AT, BE, CH, CY, DE, DK, ES, FI, FR, GB, GR, IE, IT, LU, MC, NL, PT, SE), OAPI patent (BF, BJ, CF, CG, CI, CM, GA, GN, ML, MR, NE, SN, TD, TG). Published <i>With international search report.</i>	
(54) Title: A PROCESS AND APPARATUS FOR THE PRODUCTION OF RECYCLED ORGANIC WASTE		
(57) Abstract		
<p>A process for the production of recycled material from organic waste wherein the organic waste is used as feed for earthworms such that the recycled material is produced by the earthworms as castings, wherein the feeding conditions for the earthworms are maintained such that at least part of the castings is produced in liquid form. The earthworms can be maintained in a substantially closed vessel, in a bed of said organic waste in the vessel. The bed of organic waste may have at least an upper layer substantially in the range 2 to 3 centimetres in depth, and may be provided in an oxygen rich atmosphere. The vessel may also include means for collecting the liquid castings.</p>		

**A PROCESS AND APPARATUS FOR THE PRODUCTION
OF RECYCLED ORGANIC WASTE**

This invention relates to a process and apparatus for the production of recycled organic waste.

5

The following patent specifications describe processes and apparatus for recycling organic waste, in which earthworms are utilised to break down the organic material by ingesting that material such that the material excreted by the earthworm forms the recycled material:

- 10 US Patent No. 4,108,625
 US Patent No. 4,552,726
 US Patent No. 5,082,486
 US Patent No. 4,285,719
 US Patent No. 5,285,534
- 15 European Patent No. 454595
 European Patent No. 326069
 International Patent Application No. PCT/AU94/00016 (WO94/19296)

In general, processes of the above kind are relatively inefficient. For example, the recycled
20 material may be produced predominately in solid form, in which case the bed within which
the material is formed by the action of the earthworms needs frequently to be separately
processed to remove the material, or in any event to remove the earthworms prior to disposal.

In one aspect, there is provided a process for the production of recycled material from organic
25 waste wherein the organic waste is used as feed for earthworms such that the recycled
material is produced by the earthworms as castings, wherein the feeding conditions for the
earthworms are maintained such that at least part of the castings is produced in liquid form.
In one embodiment, substantially all the castings may be so produced. In another
embodiment, a predominate proportion of the castings is formed in solid form.

30

- 2 -

In another aspect, the invention provides a process for the production of recycled material from organic waste wherein the organic waste is used as feed for earthworms such that the recycled material is produced by the earthworms as castings, wherein the worms are substantially maintained in a bed of said organic waste having at least an upper layer
5 substantially in the range 2 to 3 centimetres in depth.

In a further aspect, the invention provides a process for the production of recycled material from organic waste wherein the organic waste is used as feed for earthworms such that the recycled material is produced by the earthworms as castings, wherein the earthworms are
10 maintained in a substantially closed vessel, in a bed of said organic waste in the vessel. Preferably, the bed is provided in an oxygen-enriched atmosphere.

The invention also provides apparatus for production of recycled material from organic waste by use of the organic waste as feed for earthworms such that the recycled material is produced
15 by the earthworms as liquid castings, comprising a closeable container for containing a bed of the waste material within which the earthworms in use act upon the material to produce the liquid recycled material, the container having means for collecting the liquid castings.

Preferably, the container has receiving means for receiving said bed of material, at least a part
20 of the lower portion thereof being comprised of filter means for permitting the liquid castings to pass therethrough from the bed. In this case, the means for collecting liquid castings may be positioned underneath the filter means. A plurality of containers may be provided coupled together for collective collection of the liquid castings. The apparatus may include means for admitting air, such as oxygen-enriched air, thereinto, and means for providing moisture
25 thereinto, and regulating means for regulating the temperature of the bed and earthworms, and/or the humidity of the bed.

The invention also provides a plant for recycling organic waste, comprising means for processing the waste so as to reduce it to a particulate material, means for directing the
30 processed material to any apparatus as above-mentioned and means for extracting liquid

- 3 -

earthworm castings from the apparatus.

The invention is further described, by way of example only, with reference to the accompanying drawings, in which:

5

Figure 1 is a plan view of a processing plant constructed in accordance with the invention;

Figure 2 is a diagram of process steps performed in a processing plant constructed in accordance with the invention;

10

Figure 3 is an end view of the plant of Figure 1;

Figure 4 is a vertical cross-section of a processing device forming part of the plant of Figure 1;

15

Figure 5 is an enlarged fragmentary plan view of a part of the processing plant of Figure 1; and

Figure 6 is a view like Figure 4, but illustrating a modified processing device.

20 Referring firstly to Figures 1 and 3, the plant 10 shown comprises apparatus 15 having in this case a number of processing devices 12 arranged in vertically stacked rows supported by vertical supports 14 and horizontal supports 16, within a process room 18 having a surrounding sidewall 20, a floor 22 and a roof 24.

25 The processing devices 12 are of similar form, being as shown in Figure 4. Each comprises a somewhat rectangular container 26 with a rectangular lower portion 28 having a sidewall 30 and a lower somewhat funnel-shaped base 31. Container 26 also has a rectangular lid 32 with a roof 34, and a peripheral sidewall 36. The lid 32 is removable to enable downward access to the upwardly open lower portion 28. A bed 38 of organic material in which
30 earthworms 40 work is supported within lower portion 28 by a filter structure 42 of tray-like

- 4 -

form, being upwardly open and having a rectangular sidewall and a base. Filter structure 42 comprises two filters, a primary filter 44 and a secondary filter 46, each of tray-like form, the secondary filter 46 being nested within the primary filter 44. The primary filter 44 may be formed for example of plastics netting, with a mesh size of the order of 1 mm, the
5 secondary filter being formed of fine plastic mesh size of the order of 0.5 μm . As shown, both filters are rolled up at the ends of the bed to prevent processing of the material in bed 38 being conducted under anaerobic conditions.

A final filter 48 is formed as a rectangular structure having an outer peripheral frame 52 of
10 annular form and having a plastic mesh extending across the frame and supported thereby. The mesh may have a mesh size of the order of 0.5 mm. As shown, the filter frame 52 rests on the ledge 45, with a rectangular frame portion 56 of the bed structure 42 resting on that. The inner surface of the sidewall of the lower portion 28 of the container 26 has a peripheral groove 60, and an annular O-ring 66 is positioned in this and arranged to sealingly engage
15 the outer periphery of the structure 42, to prevent worms escaping from the structure 42 from passing therebelow and to enter the funnel-shaped base 31. The final filter 50 is likewise arranged so as to prevent worms that may escape from the base of the structure 42 from so-entering base 31.

20 When lid 32 is in position on lower portion 28, a substantially sealed enclosure is formed around the bed 38. The lower portion 28 may, alternatively or additionally be slidable on the frame portion 56 to enable it to be withdrawn from the remainder of processing device 12.

Water supply pipes 70 are arranged to supply water to the device 12. Thus, the illustrated
25 device 12 is shown as having an interior spray pipe 72 at the upper part thereof, which spray pipe communicates, via an opening in the lid portion 32 with a pipe 70 so that when water is supplied to the pipe 70, part of this enters the pipe 72 to be sprayed on the bed 38.

An air supply pipe 74 is likewise provided for supply of air to each of the devices 12. Each
30 pipe 74 communicates with an inlet pipe 76 of each device 12, which inlet pipe 76 passes

- 5 -

through an opening in the lid 32 to supply air to an upper part of the closed chamber 35 defined by the lower portion 28 and lid 32. A second branch pipe 78 associated with each device 12 passes through the respective sidewall 30, below the ledge 45, to supply air to the interior of the base 31.

5

An air outlet 80 is provided to exhaust air from the interior of lid 32 and chamber 35, at the upper part thereof. The lowermost point of the base 31 of each device 12 communicates with a respective outlet pipe 84. The outlet pipes 84 of each of the devices 12 are coupled to a common outlet (not shown) via respective one-way valves 86 which permit flow of liquid
10 from the bases 31 through the pipes 84 to that outlet, but preclude backflow.

Figure 5 shows the arrangement of pipes 70, 72, 74, 76, and 84, viewed in plan.

In use, the devices 12 are first placed in an open condition by upward lifting of the lid 32,
15 whereafter worms and particulate organic or vegetable material, prepared in a way described later, are positioned in a layer to form the bed 38 within the filter structure 42. Preferably, this bed is arranged to be of thickness, or depth, of the order of 2 to 3 cm only. The worms then consume the material and excrete liquid and solid castings. The conditions within the device 12 may be arranged, in a manner described later, so that the amount of solid castings
20 generated is relatively low and so that the liquid castings predominates. It is preferred however that the amount of solid castings generated is relatively higher, so that the solid castings predominate. For example, 60 to 65% by weight may comprise castings, with 35% being liquid. In any event, the liquid castings passes through the filters 44, 46, thence passing downwardly through the final filter 48 to be collected in the base 31 and thence to
25 flow outwardly through pipe 84 and valve 86 to the common liquid collection point.

During this processing, water is supplied as required to the bed 38, and air likewise supplied within the device 12 above the bed, both for purposes of maintaining living conditions for the worms. The air is temperature controlled so as to maintain a suitable temperature within the
30 device 12 and within the bed 38. Thus, a temperature sensor 90 is provided within the bed

- 6 -

to enable appropriate control of the temperature of the air entering the chamber. Also, the humidity is controlled by varying the rate of inflow of water and/or air in accordance with detected humidity by a detector 92 positioned in the upper part of the device 12. The provision of air from pipe 78 to the base 31 serves to pressurise the atmosphere in the chamber 35, and above the collected liquid castings, to assist in movement of the castings out through pipe 84.

It has been found, for example, that earthworms prefer a temperature in the range 20 to 20°C to 22°C, requiring in many instances that the air entering the chamber be refrigerated in summer and heated in winter. It has also been found to facilitate the process if the oxygen level of the entering air is increased above that normally prevailing.

During operation, the thickness of the upper part of the bed 38, comprising food material may be maintained at about 2 to 3 cm. That is to say, for example, food may be added periodically, such as at weekly intervals, to maintain the bed thickness in this range. In this regard, it has been found that if the bed is maintained at too great a depth, there is a tendency for the organic material to go rotten and the gases given off may kill the worms.

The feed material used may comprise generally available waste organic material, such as vegetable matter.

It is preferable that the material be reduced to particulate form before use.

The collected liquid from the plant is generally useful as organic fertiliser.

25

Figure 2 illustrates processing steps at the plant 10 from the beginning of delivery of waste organic material at a transfer station 100 to final delivery at a delivery station 150. Thus, from the transfer station 100, the material is moved on a conveyor 102 to a hammer mill 104. While moving on the conveyor, the material is subjected to process steps 130, 132, 134, 136, respectively, of metal removal, heat treatment, plastics removal and removal of non-organic

30

- 7 -

material. The heat treatment may be carried out such as to heat the material to a temperature in the range 75°C to 95°C. The removal of metal plastics and non-organic materials may be effected in known ways.

5 In the hammer mill 104, the material is reduced to particulate form, whereafter it passes through a cooling stage 106 and is then, at the step 108 shown, transported to the process room 18 and positioned within the beds 38. The step 110 shown, of extracting liquid organic fertiliser, is effected in the way described previously, via the outlet pipes 84 from the devices 12. The removed material is then subjected to sterilisation, at step 112 shown, and then
10 passed to store 114. It is then, at step 116 shown, packed or bottled and thence passed on a conveyor 118 to a conveyor transport 120 to arrive at the delivery station 150.

The process may use residue available from food manufacturers or vendors, such as vegetable markets and restaurants, the waste being processed to form the worm food prior to feeding
15 the worms. The waste may be minced together with cardboard, such as cardboard with organic glues. The cardboard may be treated before use in a solution of water and lime (such as 1:50/L for ½ day). Fresh, cooked food and shredded cardboard may be so mixed in a pre-set ratio. In this combination, the temperature may be kept in an acceptable range 19 to 24°C. Generally, the food may comprise vegetable material, bakeries (eg bread crumbs) dairy
20 products (eg cheese), cooked food and other organic materials.

The manner in which the bed is filled initially influences the process. It has been found that a layered structure is suitable for a quick and clean process. A bottom layer (thickness of 4 to 5 inches, or 101 to 127 mm) of small shredded cardboard may be covered by a fine screen
25 (plastic material - holes diameter - 0.2 to 0.5 mm). On top of that may come a first layer comprising solid worm casting (thickness - 2 cm), which supplies enough nutrients for offspring and new babies. In the same time, this layer will act as an absorbent medium for leached material from the incoming food. The worms may be set down on top of this layer in "strips" of 25 to 30 cm width, at an interval of about 25 cm apart. The food may occupy
30 the spaces between these strips. All of this may be covered with a thin layer of cardboard to

- 8 -

protect against strong evaporation. In a closed environment this layer will not be necessary, it being sufficient to cover the bed with a very fine mesh (plastic material with very low density will usually suffice).

- 5 The worms may be "Reds" (*Lumbricus Rubellus*), although most commercially available types are suitable.

Preferably, the process is carried out in subdued lighting or substantially in darkness.

- 10 It has been found that maintenance of the cardboard in a slightly alkaline state such as by use of the described water and lime treatment assists in maintaining the pH of the bed in a suitable range, bearing in mind that the vegetable material may be slightly acidic. It is preferred that the final pH so produced be about 6.8 to 7.5.
- 15 Figure 6 illustrates a modified processing device 12a. This is generally similar to the device 12 shown in Figure 4. Like reference numerals denote like components in Figures 4 and 6. The principal difference between device 12 and device 12a is that the base 31 is replaced by a modified base 31a which slopes across the width of the device 12 at an angle of, about 10 degrees. In this case the devices 12 are mounted for sliding movement on side walls 94 of the
- 20 apparatus 15. In particular, the side walls have channel-shaped rails 96 on which run rollers 98 attached to the sides of the devices 12. This permits more efficient use of stacking space for the devices and faster application of food. Thus, the food can be added when the devices are slid outwardly after which they can be slid back into position between the walls 98.
- 25 The described arrangement has been advanced merely by way of explanation any many modifications may be made thereto without departing from the spirit and scope of the invention as defined by the appended claims.

- 9 -

Throughout this specification and the claims which follow, unless the context requires otherwise, the word "comprise", and variations such as "comprises" and "comprising", will be understood to imply the inclusion of a stated integer or step or group of integers or steps but not the exclusion of any other integer or step or group of integers or steps.

- 10 -

CLAIMS:-

1. A process for the production of recycled material from organic waste wherein the organic waste is used as feed for earthworms such that the recycled material is produced by
5 the earthworms as castings, wherein the feeding conditions for the earthworms are maintained such that at least part of the castings is produced in liquid form.
2. A process as claimed in claim 1 wherein substantially all the castings produced by the earthworms are produced in liquid form.
10
3. A process as claimed in claim 1 wherein a predominate weight of the castings is produced in solid form.
4. A process as claimed in any one of claims 1 to 3 wherein the worms are substantially
15 maintained in a bed of said organic waste having at least an upper layer of food substantially in the range 2 to 3 centimetres in depth.
5. A process as claimed in any preceding claim wherein the earthworms are maintained in a substantially closed vessel, in a bed of said organic waste in the vessel.
20
6. A process as claimed in claim 5 wherein the bed is provided in an oxygen-enriched atmosphere.
7. A process for the production of recycled material from organic waste wherein the
25 organic waste is used as feed for earthworms such that the recycled material is produced by the earthworms as castings, wherein the worms are substantially maintained in a bed of said organic waste having at least an upper layer of food substantially in the range 2 to 3 centimetres in depth.
- 30 8. A process as claimed in claim 6 wherein the feeding conditions for the earthworms are

- 11 -

maintained such that at least part of the castings is produced in liquid form.

9. A process as claimed in claim 8 wherein substantially all the castings produced by the earthworms are produced in liquid form.

5

10. A process as claimed in claim 7 wherein a predominate weight of the castings is produced in solid form.

11. A process as claimed in any one of claims 7 to 10 wherein said bed is in a
10 substantially closed vessel.

12. A process as claimed in claim 11 wherein the bed is provided in an oxygen-enriched atmosphere.

15 13. A process for the production of recycled material from organic waste wherein the organic waste is used as feed for earthworms such that the recycled material is produced by the earthworms as castings, wherein the earthworms are maintained in a substantially closed vessel, in a bed of said organic waste in the vessel.

20 14. A process as claimed in claim 13 wherein the bed is provided in an oxygen-enriched atmosphere.

15. A process as claimed in claim 13 or claim 14 wherein the feeding conditions for the earthworms are maintained such that at least part of the castings is produced in liquid form.

25

16. A process as claimed in claim 15 wherein substantially all the castings produced by the earthworms are produced in liquid form.

17. A process as claimed in claim 13 or claim 14 wherein a predominate weight of the
30 castings is produced in solid form.

- 12 -

18. A process as claimed in any one of claims 13 to 17 wherein said bed of said organic waste is having at least an upper layer of food substantially in the range 2 to 3 centimetres in depth.
- 5 19. A process as claimed in any preceding claim wherein said organic waste includes vegetable material, selected from the group comprising bakeries, diary products, cooked foods and other organic material.
20. A process as claimed in any preceding claim wherein said organic waste includes
10 cardboard.
21. Apparatus for production of recycled material from organic waste by use of the organic waste as feed for earthworms such that the recycled material is produced by the earthworms as liquid castings, comprising a closeable container for containing a bed of the
15 waste material within which the earthworms in use act upon the material to produce the liquid recycled material, the container having means for collecting the liquid castings.
22. Apparatus as claimed in claim 21 wherein the container has receiving means for receiving said bed of material, at least a part of the lower portion thereof being comprised of
20 filter means for permitting the liquid castings to pass therethrough from the bed.
23. Apparatus as claimed in claim 22, wherein the means for collecting liquid castings is positioned underneath the filter means.
- 25 24. Apparatus as claimed any one of claims 21 to 23 wherein a plurality of containers is provided coupled together for collective collection of the liquid castings.
25. Apparatus as claimed in any one of claims 21 to 24 including means for admitting air, thereinto, and means for providing moisture thereinto, and regulating means for regulating
30 the temperature of the bed and earthworms, and/or the humidity of the bed.

- 13 -

26. Apparatus as claimed in claim 25 wherein the means for admitting air comprises means for introducing oxygen-enriched air.
27. A plant for recycling organic waste, comprising means for processing the waste so as
5 to reduce it to a particulate material, means for directing the processed material to any
apparatus as claimed in any one of claims 21 to 26, and means for extracting liquid
earthworm castings from the apparatus.
28. A process for the production of recycled material from organic waste substantially as
10 herein described with reference to the accompanying drawings.
29. Apparatus for the production of recycled material from organic waste substantially as
herein described with reference to the accompanying drawings.
- 15 30. A plant for recycling organic waste, substantially as herein described with reference
to the accompanying drawings.

1/6

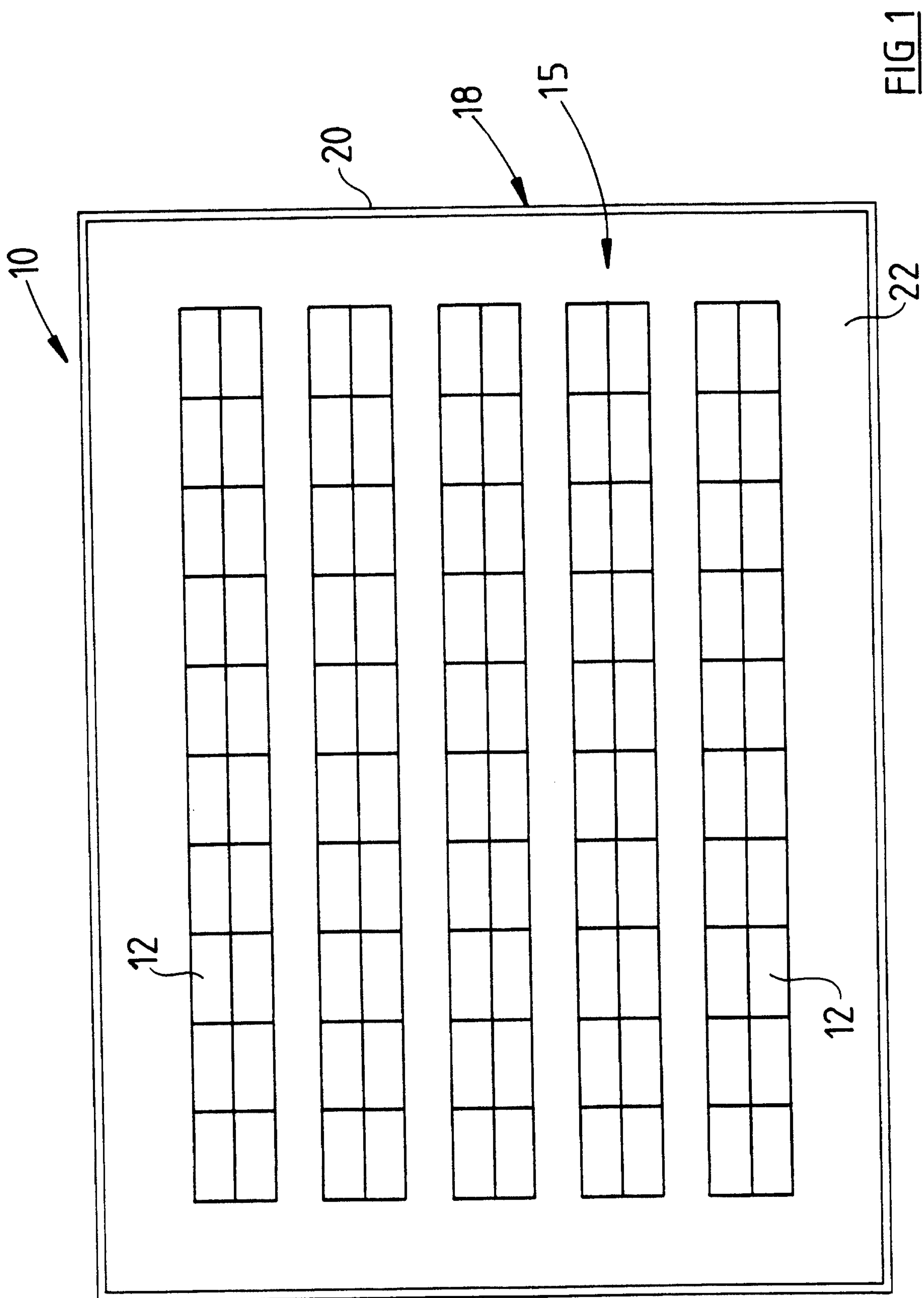

FIG 1

2/6

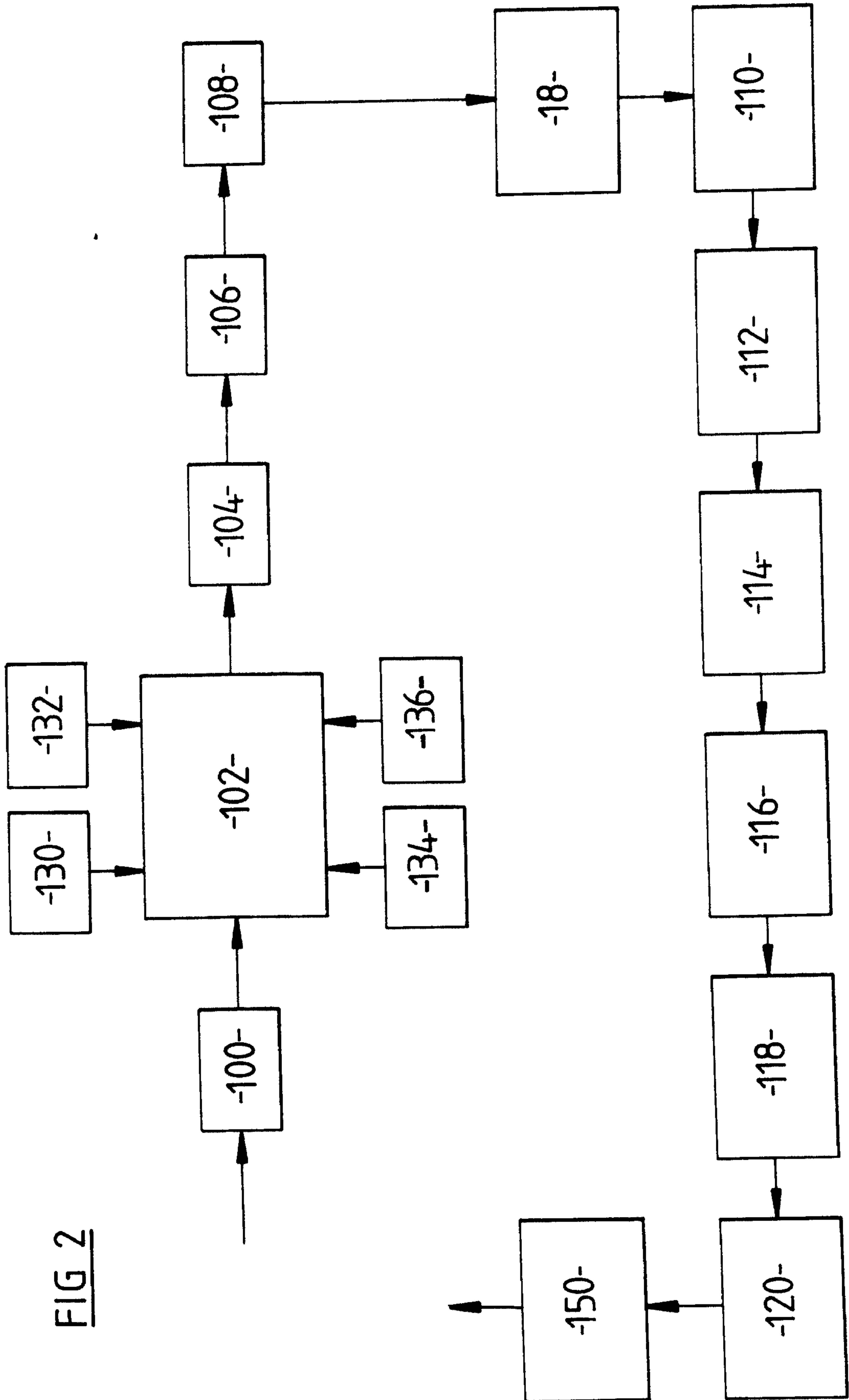
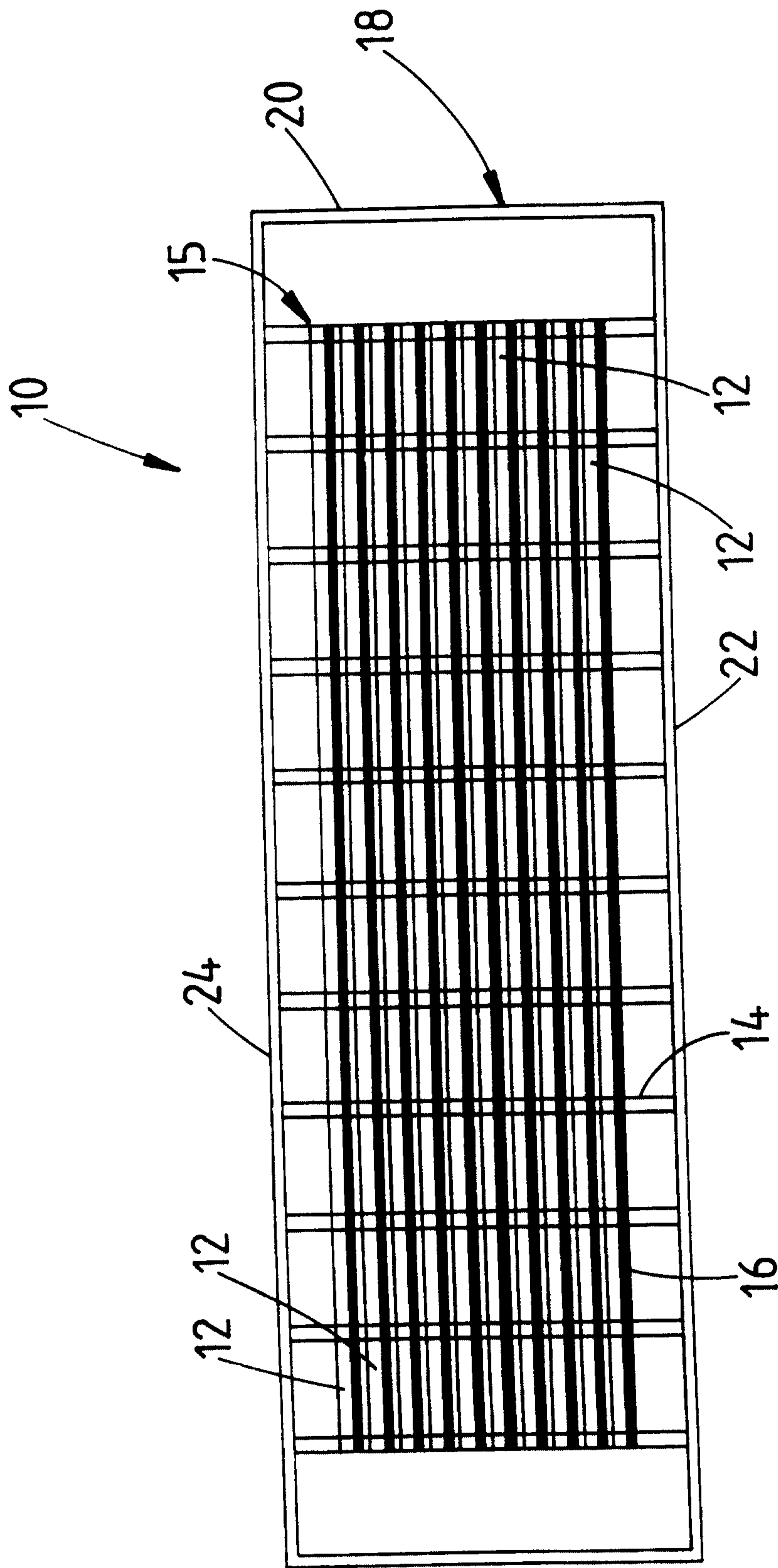

FIG 2

FIG 3



4/6

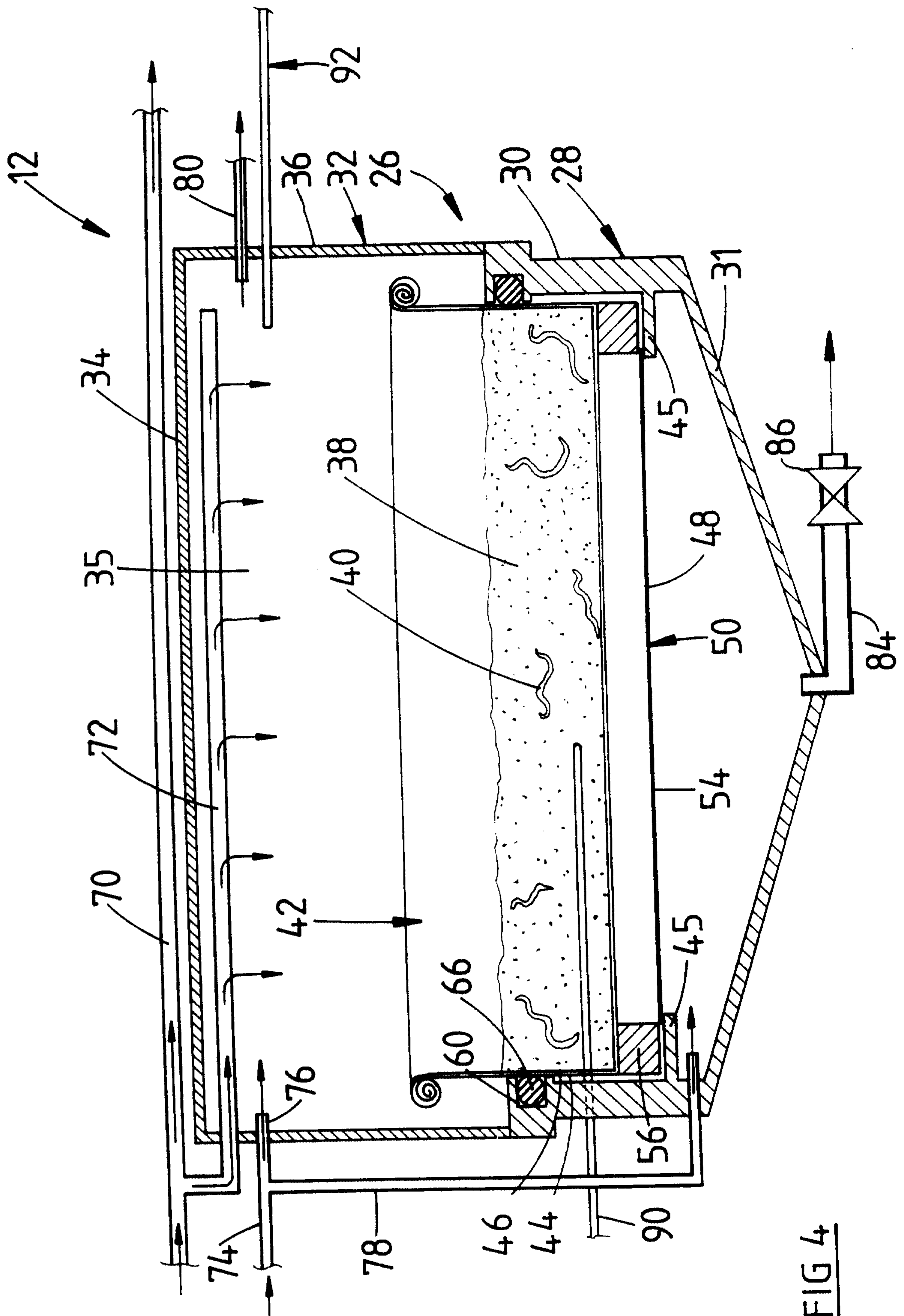

FIG 4

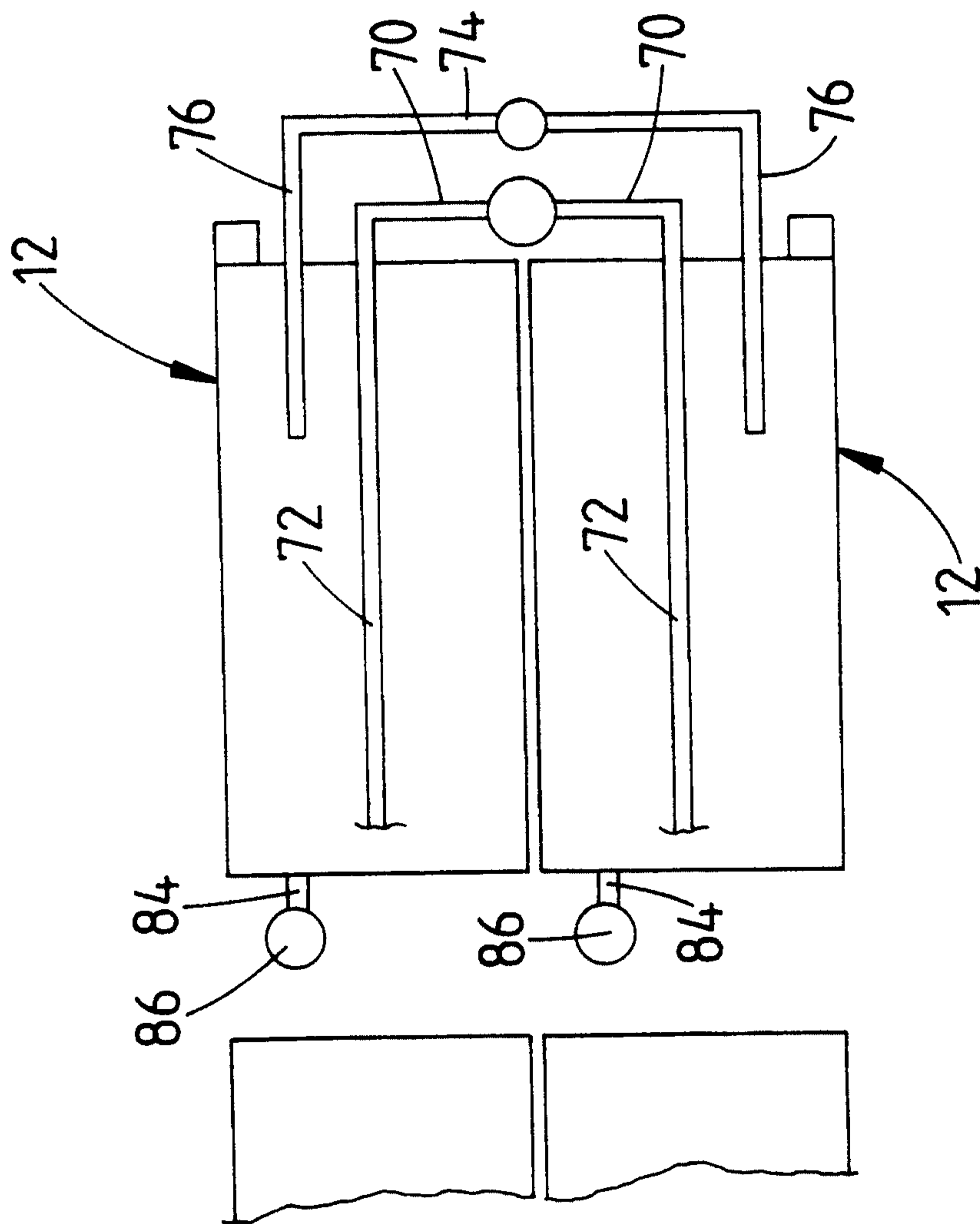

FIG 5

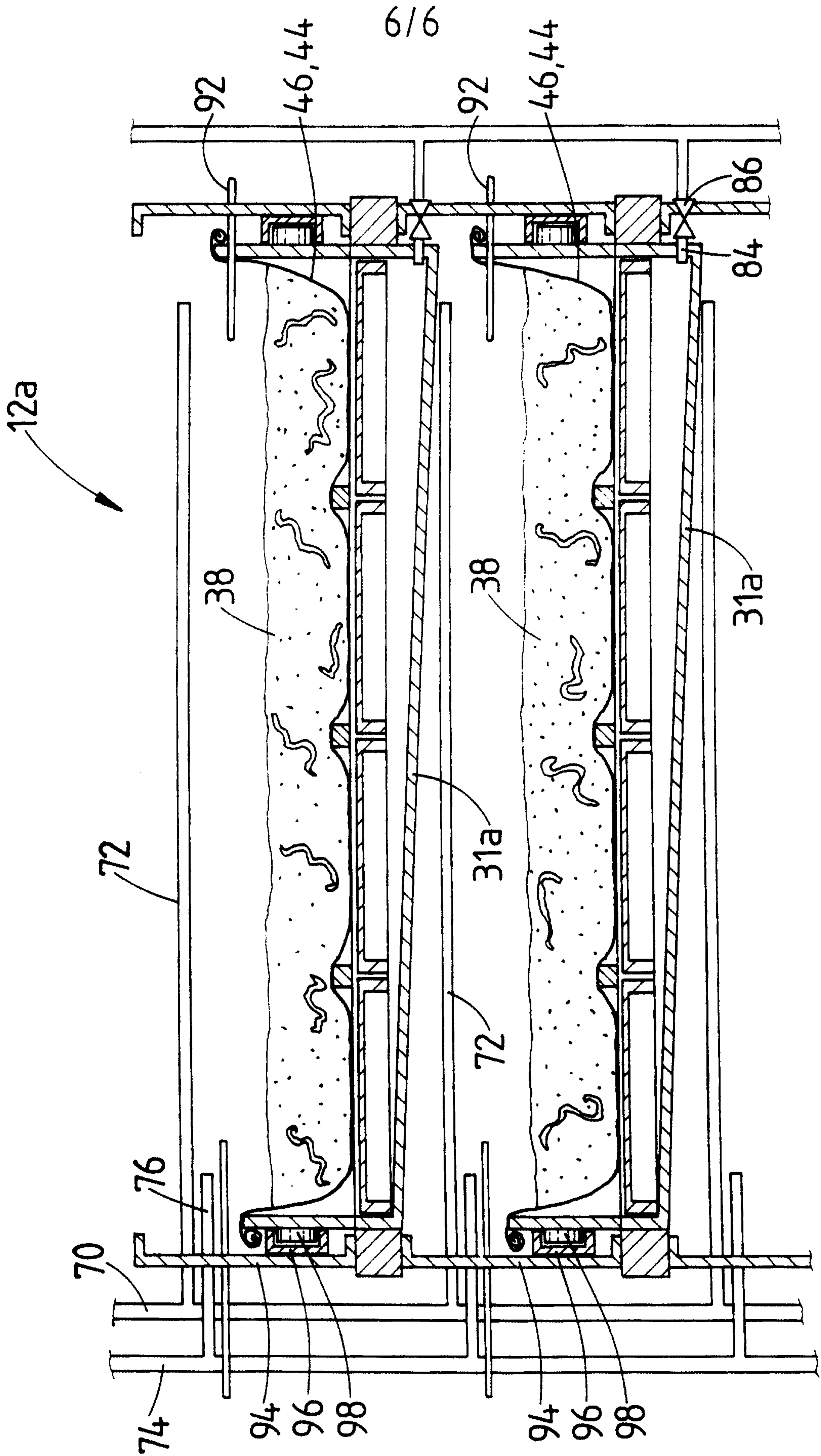

FIG 6