

(No Model.)

E. A. BYRNE & E. KOSIOL.

LUBRICATOR FOR LOOSE PULLEYS, &c.

No. 342,425.

Patented May 25, 1886.

FIG. 2.

FIG. 1.

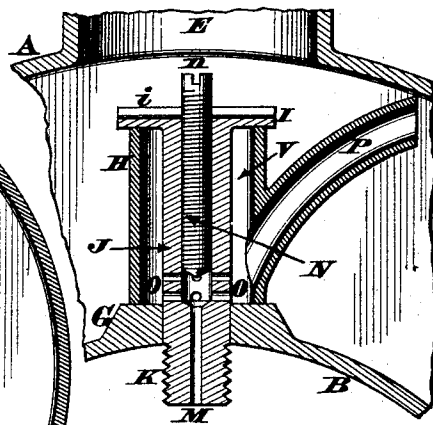
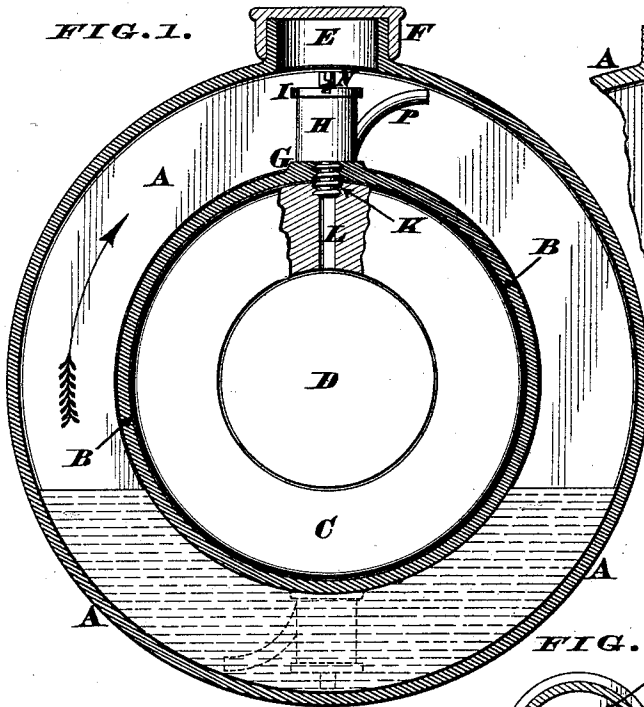

FIG. 4.

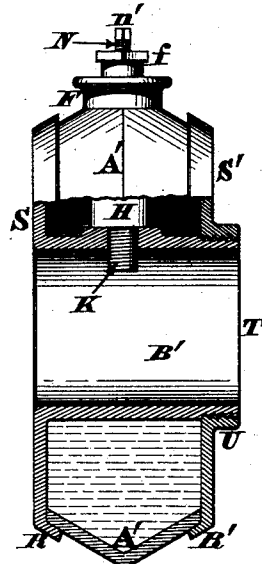

FIG. 3.

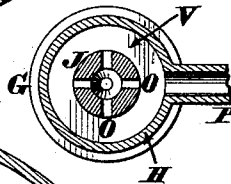

FIG. 5.

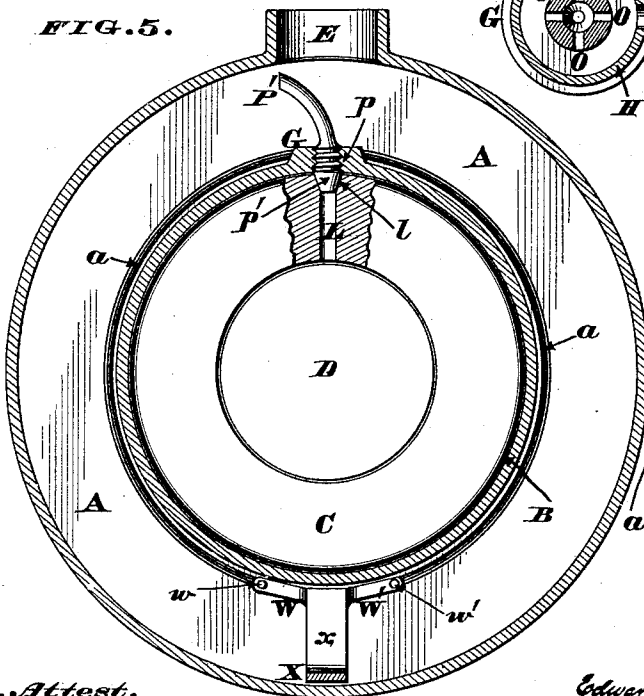
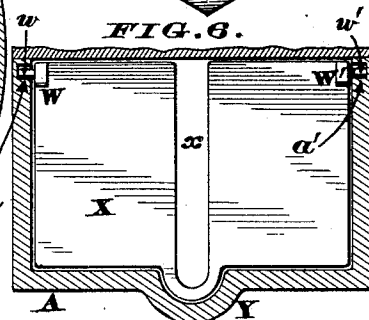

FIG. 6.



Attest.  
S. S. Carpenter,  
Ch. C. Layman

Inventors.  
Edward A. Byrne & Edward Kosiol  
By James N. Layman  
Atty.

# UNITED STATES PATENT OFFICE.

EDWARD A. BYRNE AND EDWARD KOSIOL, OF CINCINNATI, OHIO.

## LUBRICATOR FOR LOOSE PULLEYS, &c.

SPECIFICATION forming part of Letters Patent No. 342,425, dated May 25, 1886.

Application filed January 25, 1886. Serial No. 189,590. (No model.)

*To all whom it may concern:*

Be it known that we, EDWARD A. BYRNE and EDWARD KOSIOL, both citizens of the United States, residing at Cincinnati, in the county of Hamilton, State of Ohio, have invented certain new and useful Improvements in Lubricators for Loose Pulleys, &c., of which the following is a specification, reference being had therein to the accompanying drawings.

Our invention comprises a lubricator which insures a regular supply of oil to hubs of loose pulleys, drums, and other similar revolving appliances.

The device consists, essentially, of a suitable fount or reservoir having a cylindrical opening or bore of such diameter as to fit snugly around the hub of the pulley or drum, the reservoir being usually made in the shape of a hollow annulus and coupled to said hub by a short tube that communicates with an oil-channel in the former. Furthermore, this connecting-tube communicates, either directly or indirectly, with a scoop-pipe whose receiving end or mouth is so arranged as to cause the lubricant to be ejected into said tube at every revolution of the reservoir, as hereinafter more fully described.

Another feature of our invention comprises a novel combination of devices for regulating the discharge of oil through the scoop-pipe and connecting tube, as hereinafter more fully described.

Our invention further consists in providing the reservoir with a pendulous barrier that effectually retains the oil at the bottom of said reservoir, no matter how rapidly the pulley may revolve, suitable provision being made for the passage of the scoop-pipe, as hereinafter more fully described.

In the annexed drawings, Figure 1 is a vertical section of one form of our lubricator, taken in the plane of the scoop-pipe. Fig. 2 is an enlarged axial section of the feed devices of the same. Fig. 3 is a horizontal section thereof, taken in the plane of the ports O. Fig. 4 is a sectional elevation of a modification of our invention. Figs. 5 and 6 are sections of other modifications.

A represents the fount, reservoir, or other vessel that contains the lubricant, which res-

ervoir is usually made in the shape of a hollow or tubular annulus, and has a cylindrical bore or opening, B, adapted to fit snugly around the hub C of a loose pulley, drum, or other revolving appliance.

D is the shaft, spindle, or other bearing upon which the pulley is journaled.

E is the filling-neck of the fount, said neck being provided with a screw-threaded or other cap, F, the removal of which permits said fount to be charged with oil.

The interior of the fount has a raised seat, G, upon which rests the lower end of a cylinder, H, the upper end of the latter being closed by an annular flange or collar, I, of a tube, J, which tube is of less diameter than said cylinder, and is threaded externally at K to engage in the outer end of an oil-channel, L, of the loose hub C. The lower portion of tube J has a passage, M, (seen in Fig. 2,) while its upper portion is threaded internally to admit a screw plug or regulator, N, having a nick, *n*, in its outer end. *i* is a similar nick or groove in the flange or collar I.

O O are transverse ports of the feed-tube J.

P is a scoop-pipe whose inner end is attached to cylinder H and near the base of the same, while the receiving end or mouth of said pipe is in close proximity to the outer wall of the fount.

To apply this lubricator, the cylindrical bore B of the same is first slipped over the hub C, and the cap F is detached, as seen in Fig. 5, to permit the feed-regulating devices being fitted in their proper place, as follows: The cylinder H is passed down through the open neck E, and the scoop pipe P of said cylinder is turned so as to present its mouth in the direction the pulley is to revolve. The tube J is then inserted in the cylinder, and its end K is engaged with the threaded portion of the hub-channel L, after which act said tube is screwed home by inserting an implement in the nick *i* of the same. It is evident that the cylinder H is now clamped firmly upon the raised seat G, while the threaded portion K of tube J serves as a coupling that fastens the fount to the hub. After the fount is thus attached to the hub the former is filled with oil or other fluid lubricant, and the adjusting-plug N is then set so as to regulate the discharge. The

cap F being now fastened to the neck, the pulley is set in motion in the direction indicated by the arrow in Fig. 1, and as the fount is attached to the hub it is evident these two members A C must revolve together. As the oil is quite fluid or limpid, the bulk of the same naturally collects in the bottom of the fount, only a limited portion being carried around the sides or wall of the same by centrifugal action; consequently, when the fount has turned around until the cylinder H is submerged in the oil, as indicated by the dotted lines in Fig. 1, the latter is at once driven through the scoop-pipe P into the annular space V between said cylinder and the tube J. As soon as the cylinder begins to assume a vertical position, the oil flows through the ports O, and then descends the communicating channels M L, thus lubricating the shaft or bearing D at every revolution of the pulley-hub C.

In the elaboration of our invention seen in Fig. 4 the outer wall of the reservoir proper is ridge shaped, as at A', and its margins are clamped between the flanges R R' of a pair of heads, S S', the head S having a prolongation, T, that is bored out at B' to fit around the hub of the pulley or drum. Furthermore, one end of this tubular prolongation T is screw-threaded to engage either with a hollow boss, U, of the head S' or with a nut capable of being screwed onto said tube. This construction enables the reservoir to be made of glass, while the ends or heads of the same can be composed of metal.

A stuffing-box, f, is shown attached to the cap F of the filling-neck, the regulator N being passed through this box, and having a square end, n', to receive a key or wrench, in order that the feed may be controlled without detaching said cap, which is a great advantage when the shafting is near a ceiling and there is not sufficient clearance to admit a screw-driver being inserted in said filling-neck.

Either of the oilers seen in Figs. 1 or 4 will suffice when the pulley is driven at a moderate speed; but when a very high velocity is necessary we prefer using the construction seen in Figs. 5 and 6. In these illustrations annular grooves *a a'* are made in the heads or ends of the reservoir, which grooves receive knife-edged bearings *w w'* of arms W W', that project rigidly from a heavy pendulous barrier, X, interposed athwart the lower portion of the vessel A, said barrier being slotted vertically, as at *x*, to permit a free passage of the scoop-pipe P, which in this case has a screw, *p*, and nipple *p'*, but no feed-regulating appliance. The screw engages with the raised seat G, while the nipple enters a counter-bore, *l*, in the outer end of the oil-channel L. Owing to the weight of barrier X and the free manner in which it is suspended, it always hangs vertically below the axis of shaft D, and thus serves as an obstruction that arrests the oil and prevents it being carried around within the reservoir, no matter how rapidly

the pulley may revolve. At every revolution of the reservoir the scoop-pipe P' passes freely through the slot *x* without moving said barrier. Finally, in Fig. 6, a groove, Y, is made in the center of the reservoir, and the barrier is shaped to enter said groove, by which arrangement the pipe P' will be enabled to scoop up the oil as long as there is any left in the fount.

We claim as our invention—

1. An oiler consisting of a fount or reservoir completely surrounding the hub of a loose pulley or drum, and coupled to the same for the purpose of revolving therewith, said fount being provided with a scoop that is submerged at every revolution of the hub, and thereby ejects the lubricant into a channel of the latter, substantially as herein described.
2. An oiler consisting of a fount or reservoir completely surrounding the hub of a loose pulley or drum, and coupled to the same for the purpose of revolving therewith, said fount being provided with a scoop that is submerged at every revolution of the hub, and thereby ejects the lubricant into a feed-regulator communicating with a channel of said hub, substantially as described.
3. The combination, in an oiler, of an annular fount, A B, filling-neck E, cylinder H, tubular screw-coupling K M, and scoop-pipe P, said coupling K being adapted to engage with the channel of a loose pulley-hub, for the purpose specified.
4. The combination, in an oiler, of an annular fount, A B, filling-neck E, cylinder H, channeled and ported tube I J K M O, screw-threaded plug N n, and scoop-pipe P, the external thread, K, of said tube being adapted to engage with the channel of a loose pulley-hub, for the purpose specified.
5. The combination, in an oiler, of the annular fount A', clamped between the flanged heads R S R' S', the head R S having a tubular prolongation, B' T, engaging with the opposite head R' S', and the tubular screw-coupling K of the feed device H P being engaged with this cylindrical prolongation, for the purpose described.
6. The combination, in an oiler of the class specified, of a pendulous barrier suspended in the bottom of the reservoir and arranged to permit free passage of the scoop-pipe, substantially as herein described.
7. The combination, in an oiler of the class specified, of grooved reservoir A a B, bearings W w W' w', slotted barrier X x, and scoop-pipe P', which latter is adapted to pass through said slot *x* at every revolution of the reservoir, substantially as herein described.

In testimony whereof we affix our signatures in presence of two witnesses.

EDWARD A. BYRNE.  
EDWARD KOSIOL.

Witnesses:

JAMES H. LAYMAN,  
S. S. CARPENTER.