

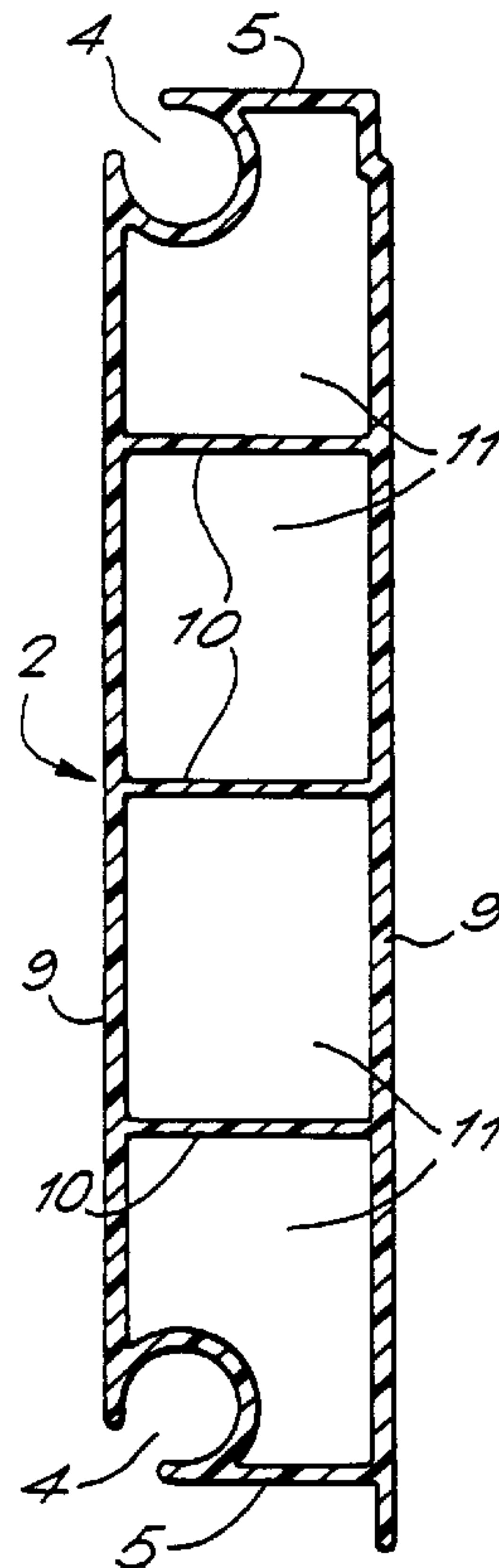

(86) Date de dépôt PCT/PCT Filing Date: 1993/07/13
 (87) Date publication PCT/PCT Publication Date: 1994/01/20
 (45) Date de délivrance/Issue Date: 2001/10/09
 (85) Entrée phase nationale/National Entry: 1994/12/29
 (86) N° demande PCT/PCT Application No.: GB 93/01462
 (87) N° publication PCT/PCT Publication No.: WO 94/01298
 (30) Priorité/Priority: 1992/07/14 (9214886.5) GB

(51) Cl.Int.⁵/Int.Cl.⁵ E06B 9/15
 (72) Inventeur/Inventor:
 Bradbury, Gordon, GB
 (73) Propriétaire/Owner:
 James & Bloom Limited, GB
 (74) Agent: GOWLING LAFLEUR HENDERSON LLP

(54) Titre : VOLETS COULISSANTS
 (54) Title: SLIDING SHUTTERS



(57) Abrégé/Abstract:

The invention relates to a sliding or roller shutter or door (1) which consists of a plurality of generally similar lathes or planks (2) hinged together by elastomeric members (6) attached to adjacent edges (5) of the lathes or planks. Preferably the edges (5) of the lathes or planks are formed with longitudinally extending key-hole shape slots (4), and the elastomeric hinge members are formed with opposite enlarged portions (7) received in the slots (4) in the lathes or planks.



INTERNATIONAL APPLICATION PUBLISHED UNDER THE PATENT COOPERATION TREATY (PCT)

(51) International Patent Classification⁵ : B60J 5/14, E06B 9/15	A1	(11) International Publication Number: WO 94/01298 (43) International Publication Date: 20 January 1994 (20.01.94)
(21) International Application Number: PCT/GB93/01462 (22) International Filing Date: 13 July 1993 (13.07.93) (30) Priority data: 9214886.5 14 July 1992 (14.07.92) GB (71) Applicant (for all designated States except US): JAMES & BLOOM LIMITED [GB/GB]; P.O. Box 14, Compstall Mill, Andrew Street, Compstall, Stockport, Cheshire SK6 5HR (GB). (72) Inventor; and (75) Inventor/Applicant (for US only) : BRADBURY, Gordon [GB/GB]; The Cottage Farm, Lily Lane, Byley, Middlewich, Cheshire CW10 9NH (GB).	(74) Agent: P.A. MAGUIRE & CO.; 12 The Broadway, St. Ives, Cambridgeshire PE17 4BN (GB). (81) Designated States: AT, AU, BB, BG, BR, BY, CA, CH, CZ, DE, DK, ES, FI, GB, HU, JP, KP, KR, KZ, LK, LU, MG, MN, MW, NL, NO, NZ, PL, PT, RO, RU, SD, SE, SK, UA, US, VN, European patent (AT, BE, CH, DE, DK, ES, FR, GB, GR, IE, IT, LU, MC, NL, PT, SE), OAPI patent (BF, BJ, CF, CG, CI, CM, GA, GN, ML, MR, NE, SN, TD, TG). Published <i>With international search report.</i> <i>With amended claims.</i> <div style="text-align: right; font-size: 2em; font-weight: bold;">2139341</div>	

(54) Title: SLIDING SHUTTERS**(57) Abstract**

The invention relates to a sliding or roller shutter or door (1) which consists of a plurality of generally similar lathes or planks (2) hinged together by elastomeric members (6) attached to adjacent edges (5) of the lathes or planks. Preferably the edges (5) of the lathes or planks are formed with longitudinally extending key-hole shape slots (4), and the elastomeric hinge members are formed with opposite enlarged portions (7) received in the slots (4) in the lathes or planks.

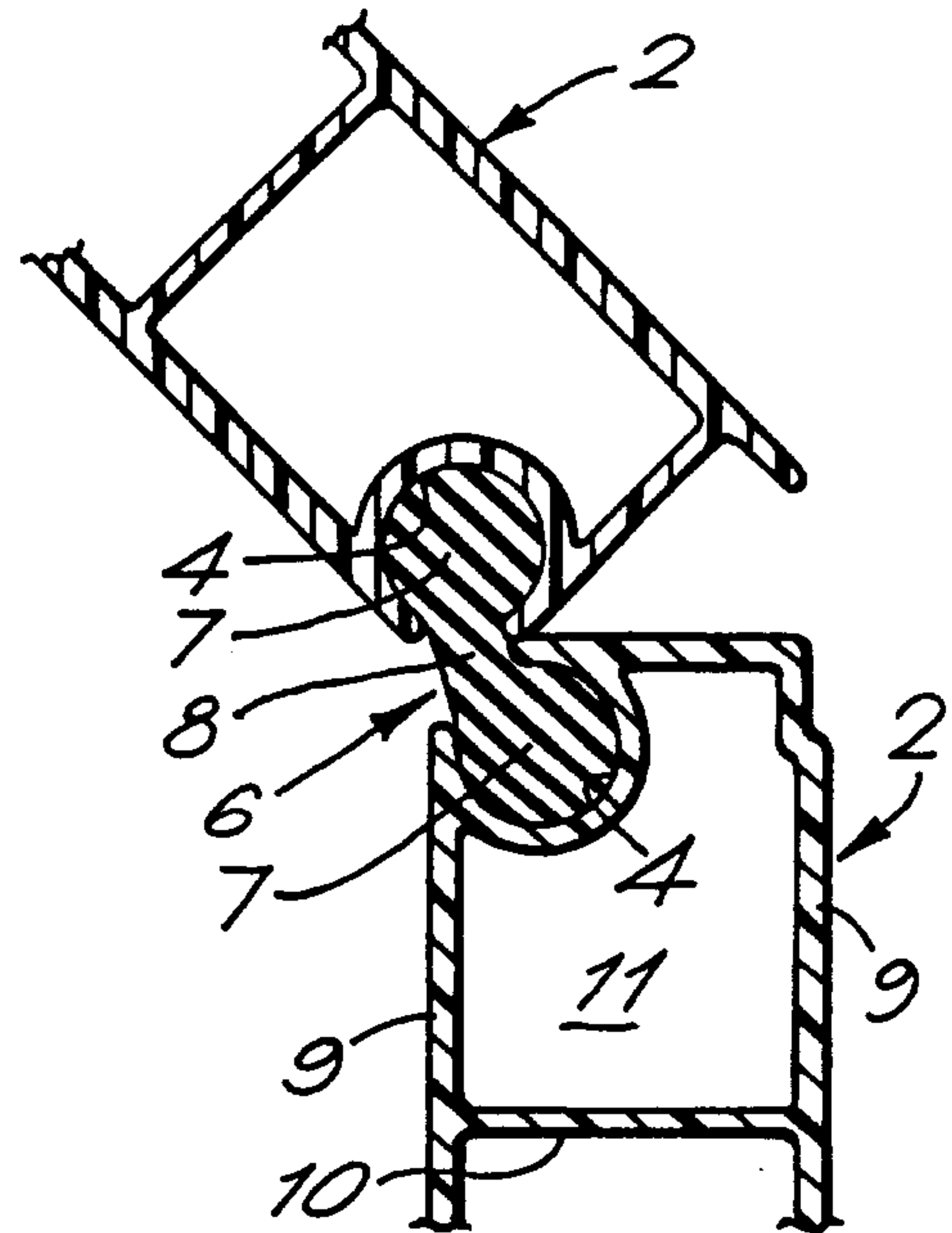

TITLE: SLIDING SHUTTERS

DESCRIPTION

Technical Field

The invention relates to sliding shutters, particularly, but not exclusively, for use as doors for the load carrying compartments of commercial motor vehicles.

Background Art

It is well known to provide a roller or 'up and over' shutter or door for closing a commercial vehicle body such as a van or truck body in the form of a vertically sliding member consisting of a series of planks or lathes made, for example, of aluminium or plywood which are hinged together and which are guided at their ends in suitable tracks in the vehicle body. Similar shutters are used for closing commercial premises and to improve the security of domestic premises.

It is an object of the invention to provide an improved sliding or roller shutter or door.

Disclosure of the Invention

According to the invention a sliding or roller shutter or door consists of a plurality of generally similar lathes or planks hinged together by elastomeric members attached to adjacent edges of the lathes or planks. Preferably the edges of the lathes or planks are formed with longitudinally extending key-hole shape slots, and the elastomeric hinge members are formed with opposite enlarged portions received in the slots in the lathes or planks. The elastomeric member will preferably be of constant

2139341

2

cross-section and may be such that the enlarged portions are joined by a web. The elastomeric members may be dumb-bell shaped in cross-section. Preferably the elastomeric hinges will be attached along the full lengths of the lathes or planks.

The lathes or planks are preferably made from a high impact plastics such as UPVC. Suitably the lathes or planks may be made by an extrusion process. If desired the lathes or planks may be twin-walled and the resulting cavity or cavities may be filled, if desired, with a thermally insulating material.

Where the elastomeric hinges extend along the full length of the lathes or planks, an air and watertight door or shutter can be produced.

Brief Description of the Drawings

The invention is diagrammatically illustrated, by way of example, in the accompanying drawings, in which:-

Figure 1 is a perspective view of an 'up and over' shutter door for a commercial motor vehicle body;

Figure 2 is a cross-section through a shutter lathe;

Figures 3a and 3b are scrap cross-sectional views of a pair of lathes of the kind shown in Figure 2, and showing their manner of interconnection and articulation;

Figure 4 is a scrap plan view of a shutter showing its associated guide members, and

Figure 5 is a scrap end view of a shutter showing how the guide members are received in a guide channel or track.

Best Mode for Carrying Out the Invention

In the drawings, an 'up and over' shutter door for a commercial motor vehicle body is shown which is conventional in its general arrangement and consisting of a sliding shutter 1 formed by a series of generally similar lathes or planks 2 hinged together along their mutually abutting edges 5 and mounted at their respective ends, which form opposite edges of the shutter, in a parallel pair of L-shaped tracks 3, whereby the shutter is movable along the tracks to open and close the door. The tracks 3, which are generally U-shaped in cross section, are mounted in a commercial motor vehicle body (not shown) so that the vertical limbs of the tracks 3 extend down both sides of the door opening and so that the horizontal limbs of the tracks 3 extend along the vehicle body near to its roof. Conventionally the planks or lathes 2 have been made of plywood joined together with metal hinges or have been made from aluminium extrusions formed integrally at their edges with mating hinge portions.

As shown in Figure 1, webbing tapes 12 are fixed to the shutter 1 and in conventional fashion are wound around a spring-urged roller 13 mounted in the vehicle body at the top of the door opening to assist the raising and lowering of the shutter. As can be seen in Figures 4 and 5, guide members are fixed to the ends of the lathes and are guided within the tracks 3 to support the shutter in position during use.

In the present embodiment, the planks or lathes 2 are

2139341₄

extruded from high impact UPVC plastics to form the hollow or twin-walled section best seen in Figure 2. In this embodiment, the lathes are generally rectangular in cross-section and have an opposed pair of face webs 9 united by opposite edge webs 5 and internal cross webs 10 which extend between the faces 9. If desired the cavities 11 defined by the hollow section can be filled with a thermally insulating material, not shown, e.g. foam plastics material.

The edges 5 of the lathe 2 are formed with oppositely disposed part-cylindrical key-hole slots 4 which extend along the edges 5 and are adapted to receive the correspondingly shaped part-cylindrical opposite edge portions 7 of an elastomeric member or strip 6 which forms a hinge uniting the planks or lathes. The elastomeric hinges comprise constant cross-section strips of rubber of the like elastomer having enlarged part-cylindrical opposite edge portions 7 joined by a web portion 8 to resemble a dumb-bell in cross-section.

The hinge members 6 are engaged with the lathes 2 by sliding one lengthwise with respect to the other so that the enlarged portions 7 of the member 6 are engaged in the key-hole slots 4. The hinge members 6 and the lathes are preferably co-extensive. As shown in Figure 3a the hinge members 6 may be slightly tensioned or stretched when the lathes 2 are in a planar relationship, such as when the shutter is closed, to improve the rigidity of the shutter.

Although as illustrated, the planks or lathes are of

double wall or skin construction they could, of course, be of single wall. Equally they could be extruded from aluminium or fabricated from other materials. Also the cross-sectional shape of the elastomeric member 6 could be different from that shown.

Industrial Applicability

The specific embodiment thus provides a sliding door or shutter which is of light weight, of high strength, of good thermally insulating properties, which is economical to produce, and which requires little or no maintenance.

1 1. A sliding shutter comprising:
2 a plurality of abutting laths having opposite substantially planar faces
3 and abutting longitudinal edges, each said lath having a slot of generally
4 keyhole shape cross-section extending along each said longitudinal edge, and
5 each keyhole slot opening from the lath at a junction between the longitudinal
6 edge and a face of the lath; and
7 an elongate flexible elastomeric hinge member of constant cross-section
8 having an opposite pair of enlarged portions and a central flexible web portion
9 connecting the opposite enlarged portions, one said enlarged portion being
10 housed in the said keyhole slot in the edge of one said lath and the other said
11 enlarged portion being housed in the said keyhole slot in the edge of an
12 abutting lath for hingedly connecting the laths in an abutting relationship,
13 the elastomeric hinge members being tensioned when the faces of the
14 laths are co-planar by folding of the central web portion about the respective
15 edges of the laths to pull said abutting edges of the laths together.

1 2. A shutter according to claim 1 wherein the elastomeric members
2 are of constant cross-section and the opposite enlarged portions are joined by
3 a web.

1 3. A shutter according to claim 2 wherein the elastomeric members
2 are dumb-bell shaped in cross-section.

1 4. A shutter according to claim 1 wherein the laths have a
2 predetermined length along their longitudinal edges and the elastomeric
3 members extend along the entire edge length of the laths.

1 5. A shutter according to claim 1 wherein the laths are formed from
2 a high impact plastic.

1 6. A shutter according to claim 1 wherein the laths have hollow
2 interiors.

1 7. A shutter according to claim 6 wherein the hollow interior of the
2 laths is filled with a thermally insulating material.

1/2

2139341

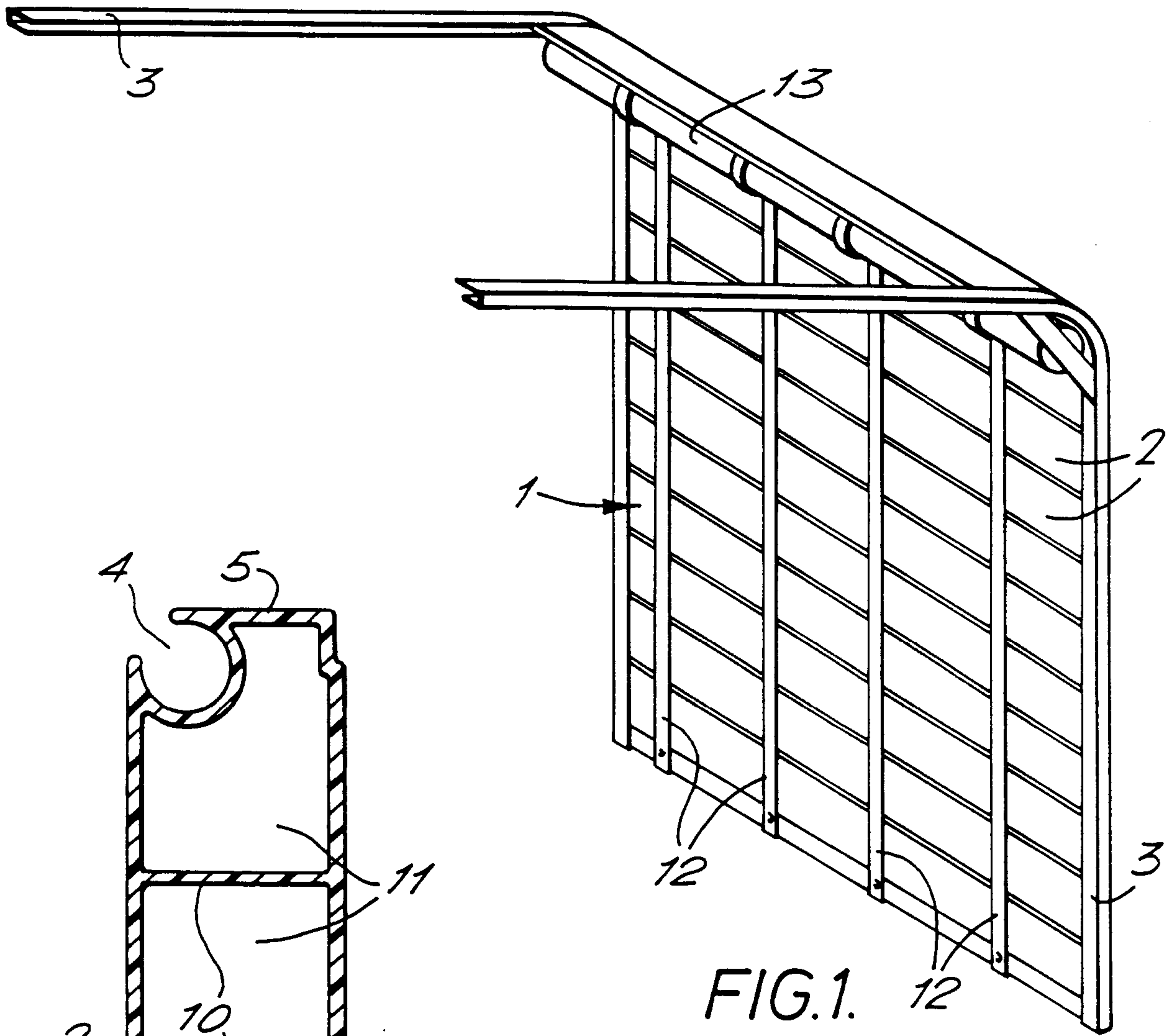

FIG. 1.

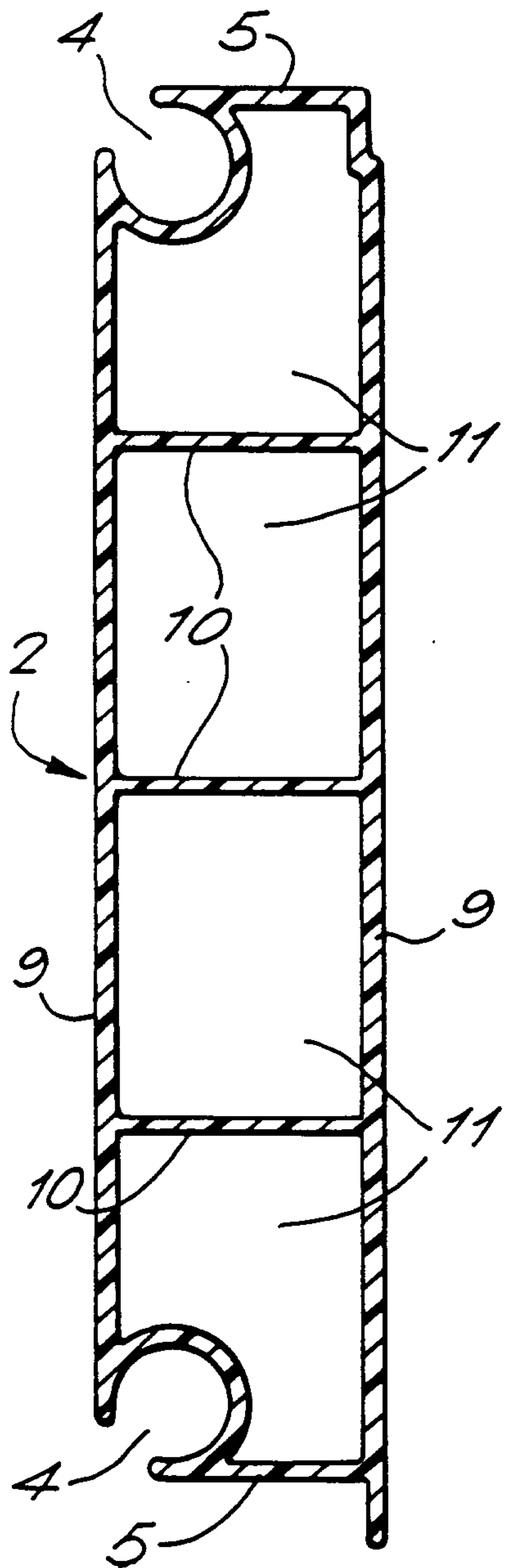

FIG. 2.

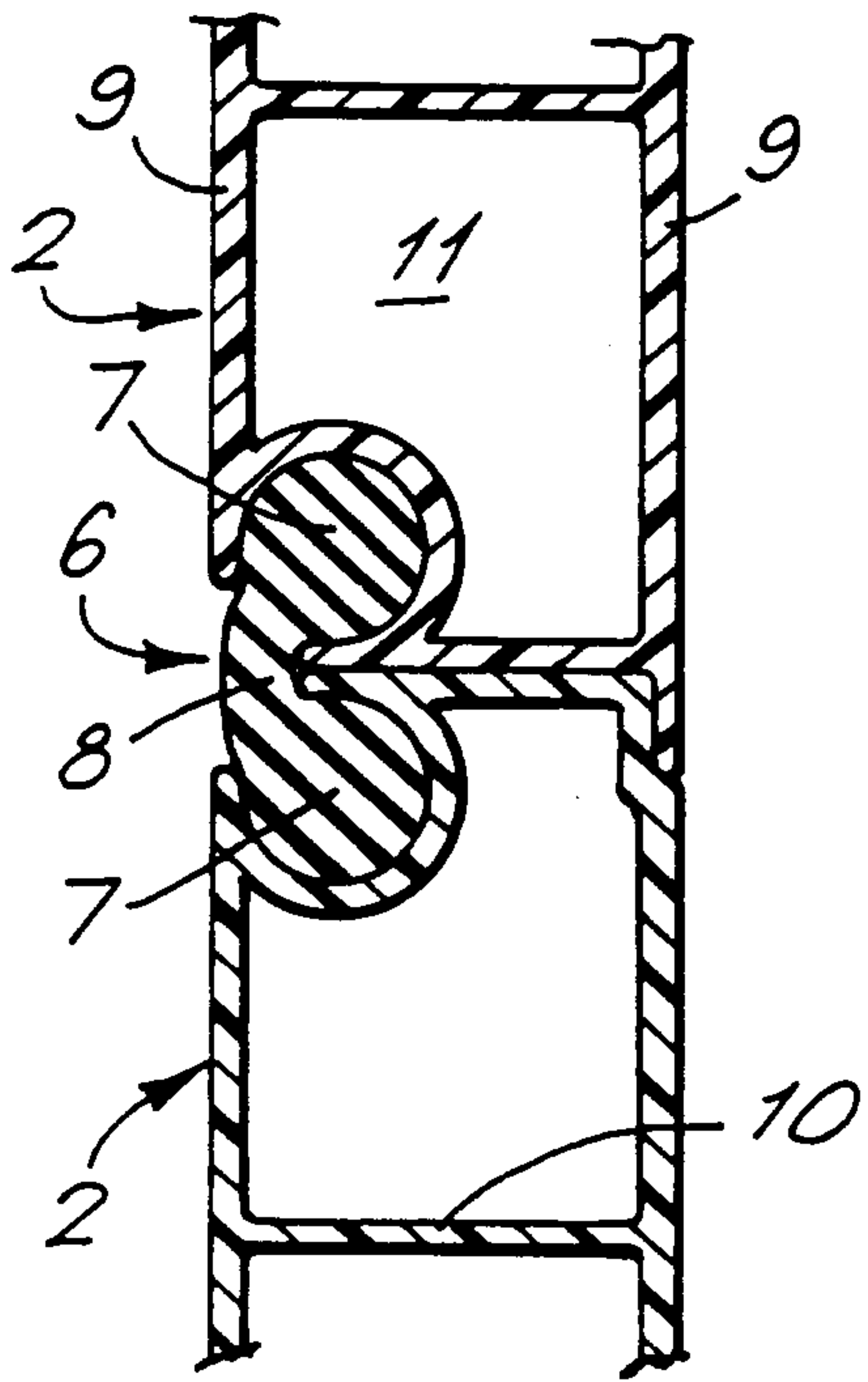

FIG. 3a.

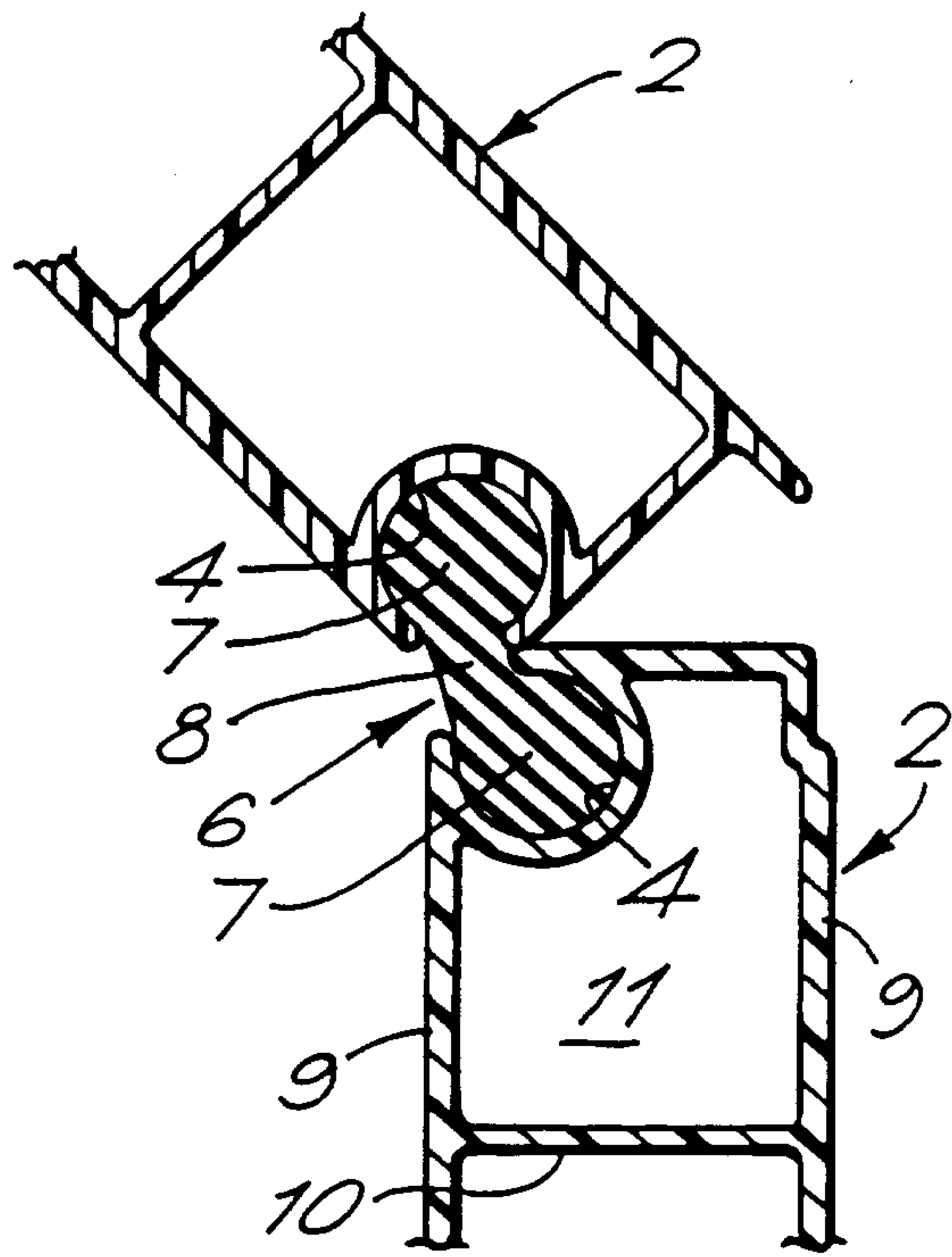

FIG. 3b.

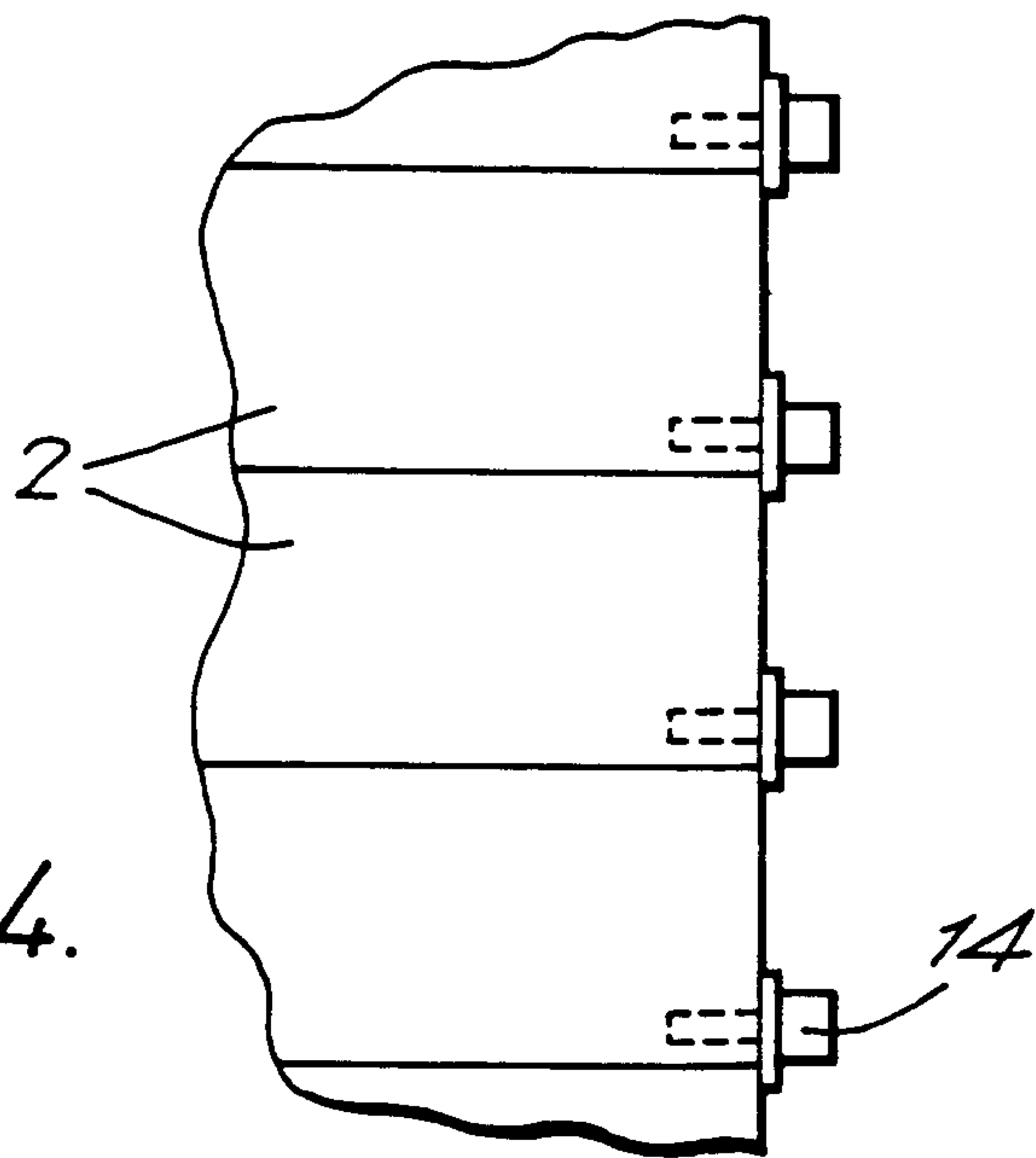

FIG. 4.

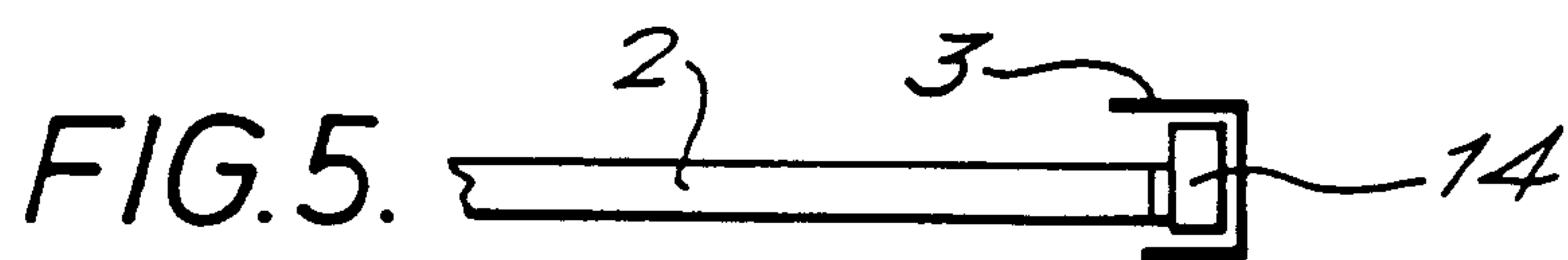

FIG. 5.

