

March 27, 1934.

A. C. JONES

1,952,257

COMBINATION LOCK

Filed Jan. 6, 1933

2 Sheets-Sheet 1

Fig. 1.

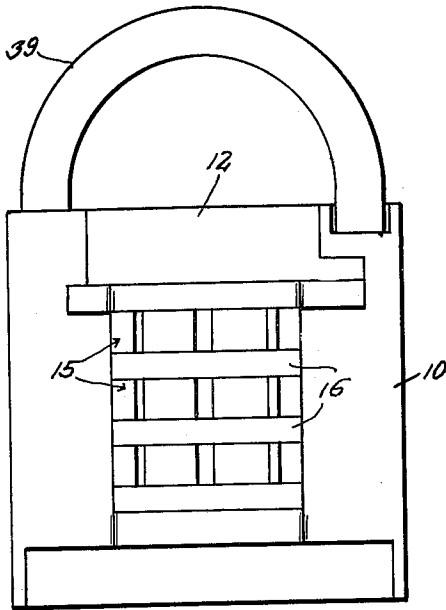

Fig. 2.

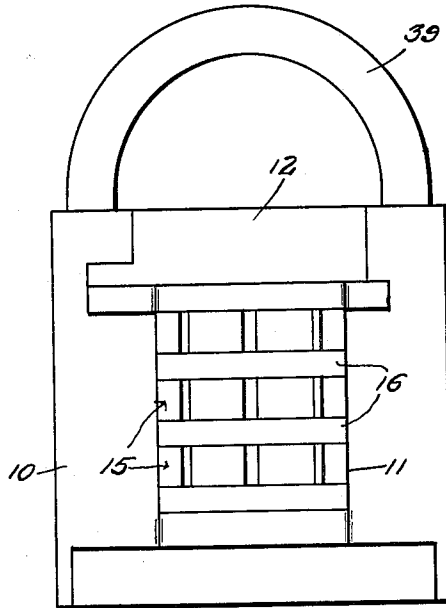
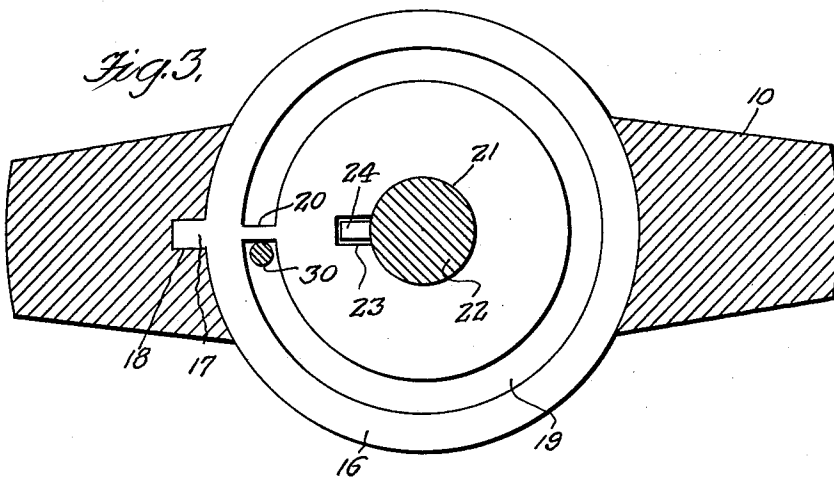

Fig. 3.



Inventor

H. C. Jones,

Fig. 8.

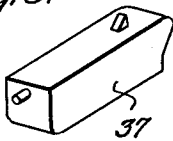

By *Clarence A. O'Brien,*
Attorney

March 27, 1934.

A. C. JONES

1,952,257

COMBINATION LOCK

Filed Jan. 6, 1933

2 Sheets-Sheet 2

Fig. 4.

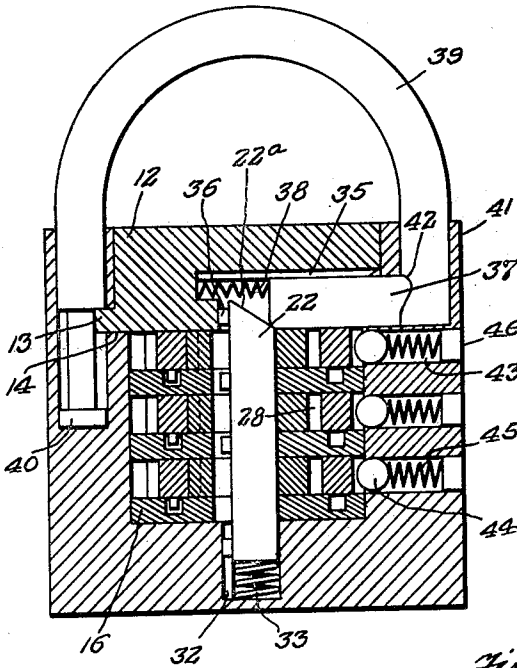

Fig. 5.

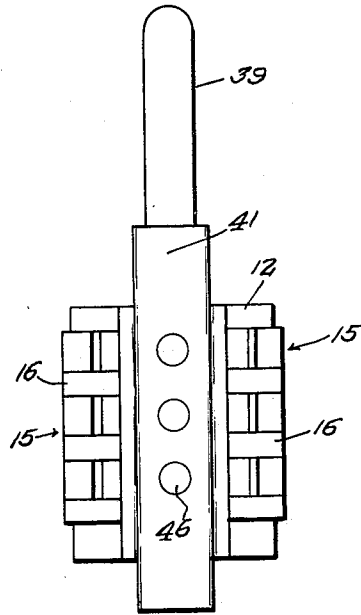

Fig. 6.

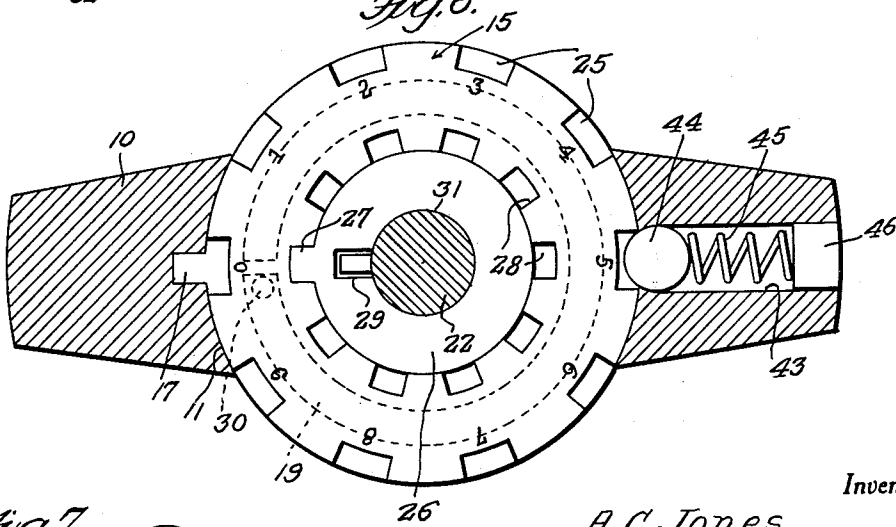
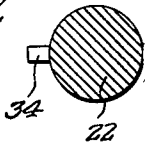

Fig. 7.



Inventor

A. C. Jones,

By Clarence A. O'Brien,
Attorney

UNITED STATES PATENT OFFICE

1,952,257

COMBINATION LOCK

Alva C. Jones, Hopkinsville, Ky.

Application January 6, 1933, Serial No. 650,565

1 Claim. (Cl. 70—113)

This invention relates broadly to locks and has more particular reference to padlocks of the combination type.

The objects of the present invention are to provide a combination padlock consisting of comparatively few parts and also one capable of a numerous variety of combinations.

The invention together with its numerous objects and advantages will be best understood from a study of the following description, taken in connection with the accompanying drawings wherein:

Figure 1 is an elevational view of one side of the lock.

Figure 2 is an elevational view of a relatively opposite side of the lock.

Figures 3 and 6 are horizontal sectional views through the lock in different planes, and illustrating certain features of the invention hereinafter more fully referred to.

Figure 4 is a vertical sectional view through the lock.

Figure 5 is an elevational view of the lock taken at right angles to Figure 1.

Figure 7 is a transverse sectional view through the spring pressed plunger and

Figure 8 is a perspective view of the locking bolt.

Referring to the drawings by reference numerals it will be seen that the lock comprises a casing or frame 10 provided with a recess 11 and a removable body part 12 for substantially closing the upper end of the recess 11. The part 12 is provided with tongues 13 slidably engaged with grooves 14 provided on opposite side walls of the recess as will be clear from a study of Figures 1, 2 and 4.

Arranged in the recess 11 are rotatable combination disks or tumblers designated generally by the reference character 15 and fixed spacer and stop disks 16. There is provided a disk 16 for each combination disk 15 and as shown clearly in Figure 3 each fixed disk 16 is provided with a lug 17 engageable in a groove 18 provided in one wall of the recess and on the top face thereof the disk 16 is also provided with a circular groove 19 and a partition wall or bridge 20 extending transversely of the groove in substantial alignment with the lug 17. At its center each disk 16 is provided with a circular opening 21 for accommodating a spring pressed bolt 22, and extending radially from the opening 21 in substantial alignment with the bridge 20 is a notch 23 for accommodating the lugs 24 projecting radially from one side of the bolt 22.

Each of the combination disks or tumblers 15 comprises an outer circular ring like member that is provided on its outer edge with a series of relatively spaced notches 25, there being preferably ten of such notches 25 and the notches as shown in Figure 6 are numbered consecutively from one to zero. The said combination disk 15 also includes an inner disk like member 26 that is provided with a lug 27 adapted to be engaged with one notch of a circular series of notches 28 provided on the inner edge of the said outer circular member of the tumbler or combination disk. The notches 28 as shown in Figure 6 correspond in number to the notches 25 and are in substantial alignment therewith. The inner disk part 26 is also provided with a notch 29 that is in alignment with lug 27.

The outer members of each of the tumbler disks 15 are provided with pins 30 arranged to operate within the grooves 19 of the disks 16 as suggested in Figures 3, 4 and 6.

The bolt 22 is slidable vertically through the openings 21 in the disk 16, and through centrally located apertures 31 provided in the inner disk parts 26 of the tumblers 15, which openings 31 as is clear, align with the openings 21.

The bolt 22 has its lower end slidably engaged in a socket 32 provided in the bottom of the casing 10 and bolt 22 is normally urged upwardly through the medium of a coil spring 33. At said lower end the bolt 22 is provided a pin 34 operating in vertical grooves in the pocket 32 as shown in Figure 4 to hold the bolt 22 against rotation.

The member 12 is also provided with a pocket 35, and the upper beveled end 22a of bolt 22 projects up into the pocket 35 as shown in Figure 4. At said upper beveled end 22a, bolt 22 is provided with a lug 36 engaging a groove in the end wall of the pocket 35. Normally projected from one end of the pocket 35 is a locking plunger 37 that is slidably engaged in the pocket 35 and is urged outwardly through the medium of a spring 38.

A hasp 39 has one end 40 slidably and pivotally engaged with the casing 10 in a manner clearly shown in Figure 4 while the other end of the hasp 39 is movable into and out of a socket 41 provided on the casing 10 diametrically opposite to the point where the end 40 is engaged with the casing. Socket 41 has the upper portion thereof opening laterally as shown in Figure 1. At said free end the hasp 39 is suitably provided as at 42 for inter-engagement with the projected end of the plunger 37 to securely lock the hasp in the position shown in the drawings.

With the parts in the position shown in Figure 4 the lock is in an unlocked condition. In this connection it will be noted that the notches 23 and 29 are in vertical alinement, and consequently by pulling upwardly on the hasp 39 the plunger 37 is caused to move rearwardly or to the left in Figure 4, and the inner end of the plunger engaging the beveled end 22a of the bolt 22 will cause the bolt 22 to move downwardly thus permitting the plunger 37 to move inwardly and release the hasp 39 so that the same may be swung upwardly to an unlocked position.

In setting the lock, each of the tumbler disks 15 has its center portion 26 thereof first set at the desired angular relation to the outer or annular portion of the disk 15, the angular relationship of the said parts of a tumbler disk being maintained by reason of the engagement of the lug 27 with the selected notch 28.

Preferably, the parts 26 of the disks 15 are offset in different angular position with respect to one another so that when the disks 15 are all rotated in an anticlockwise direction to the extent limited by reason of the pins 30 engaging the bridges 20, the notches 29 are out of alinement with one another, and with the notches 23. When the parts are thus set it will be apparent that the bolt 22 in its projected position will be prevented from moving downwardly since any tendency of the bolt 22 to move downwardly will be overcome by the fact that the lugs 29 will engage solid portions of the inner elements 26 of the combination disks 15.

To release, or unlock the lock, obviously the tumblers 15 are rotated in a reverse or clockwise direction until the notches 29 aline with one another and with the notches 23, the parts then

being in the position shown in Figure 4 and a disengagement of the hasp 39 from the plunger 37 may then be readily effected.

To facilitate setting of the lock by sound or touch, there is provided for each of the tumbler disks 15 a lateral bore or pocket 43 in one side of the casing 10 and arranged in the pockets 43 are spring pressed balls 44 that are engageable with the notches 25. The springs engaged with the balls 44 are indicated by the reference numerals 45 and are engaged at one end with plugs 46 provided for the outer ends of the bores or pockets 43.

Even though I have herein shown and described the preferred embodiment of the invention, it is to be understood that the same is susceptible of further changes, modifications and improvements coming within the scope of the appended claim.

Having thus described my invention, what I claim as new is:

A permutation-padlock having in combination a spring influenced locking bolt, a related coaxial series of disks, coacting elements on said disks and said locking bolt for locking the bolt in projected operative position, said disks including a plurality of spaced rotatable combination disks and fixed spacer disks arranged in alternate relation to the combination disks, each of said spacer disks having a circular groove in one side thereof, and a partition extending transversely of the groove, and each of the combination disks having a pin on one side thereof operating in the groove of the next adjacent fixed spacer disk and coacting with the partition for limiting rotation of its associated combination disk.

ALVA C. JONES.

40

115

45

120

50

125

55

130

60

135

65

140

70

145

75

150