



INTERNATIONAL APPLICATION PUBLISHED UNDER THE PATENT COOPERATION TREATY (PCT)

<p>(51) International Patent Classification ⁵ : B03C 3/01</p>	<p>A1</p>	<p>(11) International Publication Number: WO 92/19380 (43) International Publication Date: 12 November 1992 (12.11.92)</p>
<p>(21) International Application Number: PCT/US92/02999 (22) International Filing Date: 10 April 1992 (10.04.92) (30) Priority data: 690,672 24 April 1991 (24.04.91) US (71) Applicant: CALVERT ENVIRONMENTAL [US/US]; 5985 Santa Fe Street, San Diego, CA 92109 (US). (72) Inventors: YUNG, Shui-Chow ; 472 Via Savoy, Encinitas, CA 92024 (US). HERNDON, Mark, T. ; 31527 Corte Solinas, Temulca, CA 92390 (US). (74) Agent: KLEINKE, Bernard, L.; Laff, Whitesel, Conte & Saret, 101 West Broadway, Suite 1580, San Diego, CA 92101 (US).</p>		<p>(81) Designated States: AT, AT (European patent), AU, BB, BE (European patent), BF (OAPI patent), BG, BJ (OAPI patent), BR, CA, CF (OAPI patent), CG (OAPI patent), CH, CH (European patent), CI (OAPI patent), CM (OAPI patent), DE, DE (European patent), DK, DK (European patent), ES, ES (European patent), FI, FR (European patent), GA (OAPI patent), GB, GB (European patent), GN (OAPI patent), GR (European patent), HU, IT (European patent), JP, KP, KR, LK, LU, LU (European patent), MC (European patent), MG, ML (OAPI patent), MR (OAPI patent), MW, NL, NL (European patent), NO, PL, RO, RU, SD, SE, SE (European patent), SN (OAPI patent), TD (OAPI patent), TG (OAPI patent).</p> <p>Published <i>With international search report. Before the expiration of the time limit for amending the claims and to be republished in the event of the receipt of amendments.</i></p>
<p>(54) Title: WET ELECTROSTATIC PRECIPITATOR AND METHOD OF USING SAME</p>		
<p>(57) Abstract</p>		
<p>A wet electrostatic precipitator (20) having a cylindrical housing (24), an inlet in an upper portion (22), a nozzle (16) for delivering an atomized spray, inner and outer concentric electrodes (35A, 31) wherein the outer electrode (31) is in the form of a collector tube which is supported by top and bottom plates (57, 59). The inner electrodes (35A) are supported by a bus bar (42) which is connected to a power supply (P). An outlet (28) is connected to the interior of the housing (24).</p>		

FOR THE PURPOSES OF INFORMATION ONLY

Codes used to identify States party to the PCT on the front pages of pamphlets publishing international applications under the PCT.

AT	Austria	FI	Finland	MI	Mali
AU	Australia	FR	France	MN	Mongolia
BB	Barbados	GA	Gabon	MR	Mauritania
BE	Belgium	GB	United Kingdom	MW	Malawi
BF	Burkina Faso	GN	Guinea	NI	Netherlands
BG	Bulgaria	GR	Greece	NO	Norway
BJ	Benin	HU	Hungary	PL	Poland
BR	Brazil	IE	Ireland	RO	Romania
CA	Canada	IT	Italy	RU	Russian Federation
CF	Central African Republic	JP	Japan	SD	Sudan
CG	Congo	KP	Democratic People's Republic of Korea	SE	Sweden
CH	Switzerland	KR	Republic of Korea	SN	Senegal
CI	Côte d'Ivoire	LI	Liechtenstein	SU	Soviet Union
CM	Cameroon	LK	Sri Lanka	TD	Chad
CS	Czechoslovakia	LU	Luxembourg	TG	Togo
DE	Germany	MC	Monaco	US	United States of America
DK	Denmark	MG	Madagascar		
ES	Spain				

Description**WET ELECTROSTATIC PRECIPITATOR
AND METHOD OF USING SAME****Technical Field**

5 The present invention relates generally to an
electrostatic apparatus and method for removing
particulates from fluid streams. The invention more
particularly relates to a new and improved wet
electrostatic precipitator, and method of operating same,
10 for more efficient and effective particle removal.

Background Art

 Electrostatic precipitators have been employed for
removal of particulates in waste fluids. Typically, the
precipitators include concentric electrodes in the form
15 of an electrically conductive rod or mast disposed within
an electrically conductive collector tube. A high
voltage discharge between the electrodes ionizes
particles from the waste fluid.

 For a disclosure of various different precipitators
20 reference may be made to U.S. patents 2,748,888;
4,194,888; 4,389,225; and 4,675,029. While the
precipitators disclosed in the foregoing patents may have
been satisfactory for some applications, they have
suffered from certain drawbacks. In the first place,
25 conventional electrostatic precipitators require unduly
excessive amounts of electrical energy and are,
therefore, unnecessarily expensive to operate. This is
especially the case when very small particles, in the
submicron range, are to be removed from a waste gas
30 stream.

 In view of the foregoing, it would be highly
desirable to have an electrostatic system for removing
very small particles from waste gas streams in an
efficient manner, without requiring unduly large amounts
35 of power consumption.

When large volumes of waste gas are being treated, non-uniform and weak electrical fields present an even greater problem. Thus, in large capacity systems for handling large volumes of gas, there is even a greater demand for electrical energy for particle removal purposes. Therefore, it is even more critical to have a highly efficient and effective system.

In general, the conventional electrostatic precipitators described above may be useful with regard to handling large volumes of waste gas. The problem relates to the construction and configuration of the inner electrode. In this regard, the foregoing mentioned prior known electrodes employ various different projections extending along an inner electrode mast, in a spaced apart manner, relative to an outer collection tube. The spacing is critical, and enables the electrostatic discharge to occur between the electrodes. However, the projections, such as helical fins and discs, serve as a hinderance to the free flow of gas through the collection tubes. Additionally, such projections do not provide the highly desirable uniform electrostatic field to increase particle removal from the gas.

In view of the foregoing, it would be highly desirable to have an inner electrode disposed in such a manner relative to the outer electrode to decrease the impedance presented to the flow of gas therethrough, and at the same time provide an extremely uniform high strength electrostatic field.

As a clear example of such a system which fails in both instances, reference may be made to the foregoing U.S. patent 4,675,029, which discloses an electrostatic precipitator having an inner electrode provided with discs having static discharge projections extending radially therefrom. The discs extend radially from the inner mast outwardly toward the inner surface of a

collection tube wall to provide a small discharge gap. As a result, the discs present an interference with the free flow of gas through the collection tube, thereby increasing back pressure in an undesirable manner. Even
5 more importantly, the discs are not particularly uniform, and thus an inefficient operation occurs.

Thus, it would be highly desirable to have a new electrode arrangement for an electrostatic precipitator which would increase greatly the efficiency of its
10 operation. In this regard, the inner electrode should not present an undue impedance to the flow of gas through the collection tube, and at the same time, present a highly uniform electrostatic field.

Disclosure of Invention

15 It is therefore a principal object of the present invention to provide an electrostatic precipitator and method of using it having high intensity ionization electrodes for providing a uniform electrostatic field for more efficient and effective particle removal.

20 It is a further object of the present invention to provide such an electrostatic precipitator and method for greatly reducing impedance to the flow of fluid to be cleaned through the precipitator.

Briefly, the above and further objects of the
25 present invention are realized by providing a new and improved wet precipitator and method to enable it to be operated more efficiently and effectively.

A wet electrostatic precipitator and method include the use of concentric electrodes, the inner one of which
30 includes a discharge disc extending a short distance therefrom toward the outer electrode to reduce the impedance to waste gas fluid flow. A relatively large number of discharge points on the outer periphery of the disc provides a large number of radially extending
35 discharge paths to the outer electrode, in a very uniform

manner. In a preferred form, a large number of individual discharge points are utilized to produce a uniform field distribution. The number of discharge points is precisely determined because if the disc were
5 to have too many points, the disc would approach a smooth outer periphery and not be as effective in maintaining a uniform field. Too few points would lead to a condition of fewer individual discharges and less uniformity in the field.

10 **Brief Description of Drawings**

The above mentioned and other objects and features of this invention and the manner of attaining them will become apparent, and the invention itself will be best understood by reference to the following description of
15 the embodiment of the invention in conjunction with the accompanying drawings, wherein:

FIG. 1 is an elevational, partially cut away diagrammatic view of the electrostatic precipitator of the present invention, the precipitator being illustrated
20 in a waste gas treating system;

FIG. 2 is an enlarged sectional view of the system of FIG. 1, taken substantially on line 2-2 thereof;

FIG. 3 is a greatly enlarged plan view of a discharge disc of the circled portion of the precipitator
25 of FIG. 2;

FIG. 4 is a fragmentary sectional view of another precipitator, which is also constructed according to the invention, and which is shown with only one pair of its concentric electrodes;

30 FIG. 4A is a fragmentary sectional view of another electrostatic precipitator, which is also constructed according to the present invention, and which is shown with only one pair of its concentric electrodes;

FIG. 5 is a fragmentary sectional view of still
35 another form of a precipitator, which is also constructed

according to the invention and which is shown with only one pair of its concentric electrodes;

FIG. 6 is a fragmentary sectional view of yet still another form of a precipitator, which is also constructed according to the invention and is shown with only one pair of its concentric electrodes; and

FIG. 7 is a greatly enlarged view of the circled portion of the electrode of FIG. 3.

Best Mode for Carrying Out the Invention

Referring now the drawings, and more particularly to FIG. 1 thereof, there is shown a wet scrubbing system 10 having an inlet 11 in an upper portion 22 of a generally cylindrical housing 24 confining a wet electrostatic precipitator 20, which is constructed in accordance with the present invention. Waste gas enters the system 10 at an inlet 11, passes through a cylindrical conduit 13 into the upper portion 22 where the waste gas is saturated with a finely atomized spray of an additive, such as water, delivered by an atomizing nozzle 16 which is held in place by a nozzle plate 14, and which is shown diagrammatically to include a pair of opposed nozzles. The saturated gas then passes into the housing 24.

The electrostatic precipitator 20 produces an electrical field through which the saturated waste gas must pass. During passage, particles in the waste gas become electrically charged. The particles adhere to an oppositely charged electrodes of the precipitator and are thereby removed from the waste gas stream. The waste gas, now cleaned of the particles, passes through a demister DM, having an array of baffles, such as baffle 240, for removing moisture from the treated gas. The clean gas generally follows a flowpath P into a cylindrical clean air conduit 26 connecting an outlet 28 to the interior of the housing 24.

During operation, water under pressure is delivered through the atomizing nozzle 16, to saturate the gas. In addition, the water washes particle collecting surfaces, thereby sweeping away particles adhering thereto. The water separated from the gas in the demister DM flows into a funnel shaped portion 48 and, as a sludge containing particles removed from the waste gas stream flows out through a port 33. Water delivery may be continuous or intermittent, depending on particle loading.

Considering now the electrostatic precipitator 20 in greater detail, with reference to FIGS. 1-3, the electrostatic precipitator 20 has a plurality of inner and outer concentric oppositely poled elongated electrodes, such as inner and outer electrodes 35A and 31, respectively, disposed within the interior of the housing 24 and extending in the direction of movement of the sprayed gas flowing therethrough. A power supply P applies a high voltage to the inner electrodes, and the outer electrodes are grounded, to cause a corona discharge to occur between the concentric electrodes. The outer electrodes are all similar to one another, and only the outer electrode 31 will now be described in greater detail. The outer electrode 31 is in the form of an elongated collector tube. The tube 31 is oriented so that the gas flow path through the system 10 is along the longitudinal axis of the electrode. The tube 31 is mechanically and electrically supported between top and bottom plates 57 and 59. The collector tube 31 collects charged particles during system 10 operation. It may have an internal diameter ranging from about 8 inches to about 12 inches. In a preferred system actually constructed, the collector tube 31 has an internal diameter of about 10 inches, and is about ten feet in length.

As best seen in FIG. 1, a bus bar 42 is disposed within the housing 24 and is electrically isolated from connection therewith by insulators, such as the insulator 43. Suspended from the bus bar 42 and electrically
5 connected are the individual like inner electrodes, such as the inner electrode 35A. The inner electrodes are each fixed in concentric alignment with the corresponding collector tubes, and extend from the bus bar 42 terminating at their bottom distal ends (not shown)
10 spaced above the plate 59.

The high voltage power supply P is electrically connected to a power supply input 44 for delivery of negative electrical energy to the bus bar 42 to create an electrostatic field between the inner electrodes and the
15 grounded outer electrode tubes. It has been determined that the system works well with a field strength of about 6KV/cm, for effective particle removal. The ends of the bus bar 42 are positioned within a pair of similar insulator purge boxes 46 and 46A. The insulator box 46
20 has the power supply input 44, and an inlet 47 through which heated dry air may be delivered into the hollow interior of the box 46 and out its outlet 47A connected in fluid communication with the interior of the housing 24, for purging the box 46 of moisture and for
25 maintaining the bus bar 42 in a substantially dry state. The other box 46A also is purged in a similar manner.

During operation of the system 10, additive introduced through the nozzle 16, flows along the surfaces of the collector tubes, thereby washing away any
30 particles deposited on the surfaces of the electrodes. Thus, in large measure, the system 10 is substantially self cleaning during the particle removal operation. However, the system 10 may be adapted so that the surfaces of the electrodes can be cleaned of particles in
35 an easy and convenient manner, without disassembly of the

system. In this case, water under pressure is delivered through a plurality of nozzles, such as a nozzle 34. The nozzles, such as the nozzle 34, are connected in fluid communication with a manifold 37 disposed in the upper portion 22 of the housing 24 upstream of the precipitator 20. An external connector 36 is adapted for receiving a water delivery line (not shown) for admitting water or other suitable cleaning liquid under pressure to the manifold 37. The nozzles 34 direct the water, under pressure, downwardly through the interior of the housing 24 for cleaning the system by removing particles from the electrodes.

Considering now the inner electrodes in greater detail, only electrode 35A will now be described since the other inner electrodes are similar to it. As shown in FIGS. 1-3, the electrode 35A is in the form of an electrically conductive elongated rod or discharge mast 32 axially aligned with, and centered disposed within, its collector tube 31. Discharge discs 38, 39 and 41, are mounted on the mast electrode 32, in a spaced apart relationship along the top portion thereof. In the system actually constructed, the discs are spaced at approximately one foot intervals.

The discharge discs 38, 39 and 41 are electrically and mechanically connected to the mast 32 so that the plane of the disc is transverse to the longitudinal axis of the electrode 32. Each discharge disc is thin, and in the constructed system, is approximately 1/8 inch thick. The discs are preferably constructed of noncorrosive electrically conductive material such as stainless steel. It is recognized, of course, that materials such as zirconium and titanium are also suitable.

Considering now the discharge disc 38, for example, in greater detail, with reference to FIG. 3, the disc has a large number of radially extending sharply pointed

projections or points, such as the points 73 and 77 to enable an individual corona discharge to be established between the radial discharge points and the inner surface of the collector tube. In this manner, a uniformly distributed electrostatic field is established, due to the sharpness of the points and the relatively large number thereof for a given circumference of the disc. Also, the diameter of the disc is only somewhat greater than the diameter of the mast, to provide only a small impedance to the flowing wet gas therepast. Thus, in accordance with the present invention, each discharge disc is able to not only provide a uniformly distributed electrostatic field, but also a low impedance to gas flow. As a result, the precipitator is highly efficient and effective in its particle removing operation

Arcuate shaped interconnecting web portions, such as the portion 75, are concave in shape, and join the discharge points along the peripheral edge of the disc. As shown in FIGS. 3 and 7, each of the points, such as the point 73, has a pair of curved opposite side edges 73A and 73B. As shown in FIG. 7, the side edges 73A and 73B form an included angle T of between 55° and 65° , with a preferred range of 59° to 61° and a most preferred angle of 60° . In the system which was constructed, each of the side edges 73A and 73B has a radius of curvature ranging from about 0.009 inches to about 0.111 inches, with a preferred range of about 0.110 inches.

It has been found that increased system efficiency and economy are achieved when the disc 38 has a large number of points disposed along its periphery. In the constructed system, the disc has 50 points arrayed along the periphery of the disc 38. The corona discharge thus produced is very stable and the electrostatic field is more efficient in particle removal. In addition, field fluctuations are significantly diminished.

The relative dimensions between the discharge disc 38 and the mast electrode 32 are found to be critical. The discharge disc should be sufficiently small to present low impedance to the gas flow around it, yet
5 capable of maintaining a high intensity uniform field. It has been found that in the discharge disc 38, as best seen in FIG. 3, a tip to tip diameter dimension D, is between about 1.575 to about 1.825 times the rod diameter d with a preferred range of about 1.64 to about 1.76, and
10 a most preferred dimension D being about 1.7 times the diameter d. Thus, in the constructed system, the disc 38 has a dimension D of approximately 3.4 inches, while the rod diameter d is approximately 2.0 inches.

It has been found that the 1.7 ratio is critical.
15 If, for example, $\frac{D}{d}$ is too large, the disc presents too high an impedance to gas flow, and thus precipitator efficiency is reduced to an unacceptable level. Also, when the disc diameter is too large for a given diameter mast, sparks (and not the desired corona discharge) are
20 established between the inner and outer electrodes, at too low a voltage. Also, in small diameter masts, relative to the size of the diameter of the disc, unwanted coronal discharges from the mast itself are produced, when, of course, it is desirable that the
25 discharge emanate from the disc electrode. Such discharges or sparks are wasteful of electrical energy and, in addition, lead to an inefficient particle removal operation.

On the other hand, where the disc/mast relationship
30 $\frac{D}{d}$ is too small, inefficient system performance results because the electrostatic field between the disc tip and the tube wall is not readily established and maintained in a desired manner.

Another critical consideration with regard to the precipitator 20 of the present invention is related to the number of discharge disc points 73 per mast circumference inch. It has been found in the constructed system for example, that 50 discharge points per discharge disc are preferred, when $D = 3.4$ inches and $d = 2$ inches. In this case, the number n of points per mast circumference inch is about 7.95. While this is a most preferred value for n , it has been found that ranges of 6.2 to 8.8 and 7.6 to 8.4 are also suitable. In the case where system operations may require a mast diameter which is more or less than 2 inches, the desired number n of discharge points per mast circumference inch, can be readily calculated from the formula $n = \frac{50}{\pi d}$ where d is the new mast diameter.

Considering now the tube electrode 31 in greater detail, with reference to FIGS. 1 and 2, the electrode, in the constructed system, has an inside diameter of ten inches. In this case, a preferable mast diameter is about 2 inches for maintenance of a uniform electrostatic field.

With regard to the radial spacing distance S (FIG. 2) between the collector tube 31 inner wall and the periphery of the discharge disc 38, the formula for a preferred spacing would be:

$$S = D_t - D$$

where S is the distance between a tip of one of the points of the discharge electrode and the inner wall, D_t is the distance between the inner wall and the axis of the mast electrode 32 and D is the maximum point tip to point tip dimension of the discharge disc 38 (FIG. 3). Thus, in the constructed system, the collector tube 31 has an internal diameter of about 10 inches, application

of the formula reveals that a suitable distance S would be from about 3.0 inches to 3.6 inches with a preferred range being about 3.2 to about 3.4 inches and a most preferred distance about 3.3 inches.

5 As in the case of the discharge disc 38, the collector tube 31 and the mast 32 are made of suitable corrosion resistant, conductive materials such as stainless steel.

10 With reference now to FIG. 4A, there is depicted another precipitator 120, which is also made according to the present invention. The precipitator 120 is generally similar to the precipitator 20, with the exception of the configuration of the collector electrode 131.

15 In FIG. 4A, there is shown for illustration purposes, only one of a pair of concentric electrodes 135 and 131, respectively. The other like electrode pairs and the other portions of the precipitator 120 are not shown for sake of simplicity.

20 The inner electrode 135 is similar to the inner electrode 35A of FIG. 1, and includes a mast 132 having spaced apart discharge discs, such as the disc 138, disposed thereon.

25 The electrode 131 is generally rectangular in cross section throughout its length and is comprised of four walls 141-144. The transverse cross sectional shape is preferably square. While the electrode 131 operates in a generally similar manner to the electrode 31 of FIG. 1, and is generally similar in particle removal function, the configuration of the walls 141-144 render the
30 electrode 131 less expensive to manufacture than the cylindrically shaped electrode 31 of FIG. 1. In this form of the invention, a mast electrode 132 having a discharge electrode 138 mounted thereon is centrally and coaxially positioned within the squared tubular collector
35 electrode 131.

Referring to FIG. 4, there is shown another electrostatic precipitator 62C which is constructed according to the present invention. The precipitator 62C is generally similar to the precipitator 20 of FIG. 1 in structure and particle removal function, except for the shape of the discharge discs. Thus, only a portion of the disc and the mast are illustrated.

The precipitator 62C includes an inner electrode E having a mast 55C and a discharge disc 38C. A large number of discharge points 81 are arrayed along the peripheral edge of the discharge disc 38C. The discharge points 81 are each defined by a generally curved side edge and a straight side edge to provide an asymmetrical discharge point. For example, a point 82 is defined by a curved side edge 83A and a generally straight side edge 83B.

As previously described with regard to the electrode disc 32 of FIG. 1, it is critical to have a large number of discharge points arrayed around the periphery of the disc. The preferred number of points may be calculated according to the foregoing formula.

Referring to FIG. 5, there is shown yet another electrostatic precipitator 62D which is constructed according to the present invention. The precipitator 62D is generally similar to the precipitator 20 of FIG. 1 in structure and particle removal function, except for the shape of the inner electrode discharge discs.

The precipitator 62D of FIG. 5 includes an inner electrode F having a mast electrode 55D and a discharge disc 38D. The disc 38D includes a plurality of peripherally arrayed, radially extending points 86 disposed on the outer edge of the disc 38D. Each point is defined by a pair of generally straight, unequal length side edges forming a V shaped discharge point. For example, a point 86A includes a side edge 84, which

is approximately twice the length of its other side edge 85.

In the case of the precipitator 62D and as discussed with regard to the disc electrode 32 of FIG. 1, it is
5 desirable to have a large number of points arrayed around the periphery of the disc 38D. The preferred number of points may be calculated according to the foregoing formula.

As shown in FIG. 6, an electrostatic precipitator
10 62E is illustrated and is constructed according to the present invention. The precipitator 62E is generally similar to the precipitator 20 of FIG. 1 in structure and particle removal function, except for the shape of the discharge disc.

15 The precipitator includes an inner electrode I having a mast electrode 55E and a discharge disc 38E. In this form of the invention, the disc 38E includes a plurality of spike shaped discharge points, such as the discharge point 88, extending radially outwardly from the
20 discharge disc 38E in a plane transverse to the axis of the mast electrode 55E. In a preferred embodiment of the precipitator 62E, the length l of the spike 86 is approximately equal to the width w of an annular hub H of the disc electrode 38E.

25 The electrostatic precipitator of the present invention has many significant advantages. In the first place, it produces a high intensity ionizing electrode configuration to concentrate the charging field in the zone between the disc and the collecting tube electrode.
30 Thus, the performance of the system exceeds conventional designs and results in more efficient operation. Further, the disc configuration provides excellent collection of particulate matter over a broad spectrum of sizes.

While particular embodiments of the present invention have been disclosed, it is to be understood that various different modifications are possible and are contemplated within the true spirit and scope of the appended claims. There is no intention, therefore, of limitations to the exact abstract or disclosure herein presented.

What is claimed is:

1. An electrostatic precipitator for removing particles from a gas stream comprising:
 - an inner and an outer electrode;
 - 5 power supply means for supplying discharge potential between said inner electrode and said outer electrode to cause a corona discharge therebetween;
 - said inner electrode including an elongated sleeveless one piece unitary mast having a diameter d and
 - 10 a plurality of spaced apart like discharge discs, each of said discs having a number of individual discharge points to provide individual electrostatic discharges between individual points and the outer electrode to form a uniform electrostatic field wherein the number of
 - 15 discharge points per mast circumference inch equals at least substantially $\frac{50}{\pi d}$ where d equals the mast diameter measured in inches, and wherein a diameter ratio value of $\frac{D}{d}$ is between about 1.6 and about 2.0 where D is the distance measured in inches between diametrically opposed
 - 20 point tips, to provide a thick, sturdy mast for support purposes and to provide a relatively large number of discharge points per mast circumference inch.
2. A precipitator of claim 1, wherein $\frac{D}{d}$ is 1.85.
3. A precipitator of claim 1, wherein $\frac{D}{d}$ is 1.70.
- 25 4. A precipitator of claim 1, wherein said outer electrode has an elongated cylindrical configuration and said inner electrode is coaxially and concentrically aligned therewith in a spaced apart relationship therewith.
- 30 5. A precipitator of claim 1, wherein said outer electrode has an elongated configuration, rectangular in cross section, and said inner electrode is coaxially

aligned therewith in a spaced apart relationship therewith.

6. A precipitator of claim 1, wherein said outer electrode has an elongated configuration, generally square in cross section, and said inner electrode is
5 coaxially aligned therewith in a spaced apart relationship therewith.

7. A precipitator of claim 1, wherein said discharge disc has a plane transverse to the axis of said
10 inner electrode.

8. An electrostatic precipitator of claim 1, wherein said points are arrayed in a plane transverse to said mast.

9. An electrostatic precipitator of claim 4,
15 wherein said outer electrode has an internal diameter of between 8 and 12 inches.

10. An electrostatic precipitator of claim 4, wherein said outer electrode has an internal diameter of about 10 inches.

20 11. An electrostatic precipitator of claim 1, wherein the distance S between the inner wall of the outer electrode and the tip of a discharge point is calculated from the formula $S = D_t - D$ where D_t is the distance between said inner wall and the axis of the
25 mast.

12. An electrostatic precipitator of claim 1, wherein said outer electrode is generally rectangular in cross section.

13. (Amended) A method of precipitating particles
30 from a gas stream comprising:

using an electrostatic precipitator having inner and outer electrodes, the inner electrode including a mast having a diameter d , and a plurality of like discharge discs, each of said discs having a number of
35 individual discharge points wherein the number of

discharge points per mast circumference inch equals at least substantially $\frac{50}{\pi d}$ where d equals the mast diameter

measured in inches, and wherein a diameter ratio value of $\frac{D}{d}$

is between about 1.6 and about 2.0 where D is the
5 distance measured in inches between diametrically opposed point tips;

establishing an electric discharge potential between the inner and outer electrodes;

10 flowing the gas stream under pressure through the electrostatic discharges to cause unwanted particles to become electrically charged; and

removing the charged particles from the gas stream.

14. A method according to claim 13, further
15 including forming a particle containing sludge and removing the sludge from the precipitator.

15. A method according to claim 13, including providing an electrical field strength of about 6KV/cm between the inner electrode and the outer electrode.

20 16. A method according to claim 13, including saturating the gas stream with moisture.

17. A precipitator according to claim 1, including means for saturating the gas stream.

25 18. A precipitator according to claim 1, including means for providing electrical energy to said inner electrode to cause a coronal discharge between the inner electrode and the outer electrode.

30 19. A precipitator according to claim 1, including a housing, a bus bar disposed within said housing and means for electrically isolating the bus bar from the housing wherein the bus bar is electrically connected to said inner electrode.

20. A precipitator according to claim 19, including means for maintaining the bus bar in a substantially dry state.

21. A precipitator according to claim 20, including
5 means for flowing heated dry air under pressure over the bus bar for maintaining it in a substantially dry state.

22. A precipitator according to claim 1, wherein each of said discharge points has a pair of curved opposite side edges, said edges forming an inclined angle
10 of between 55° and 65°.

✓ Fig. 1

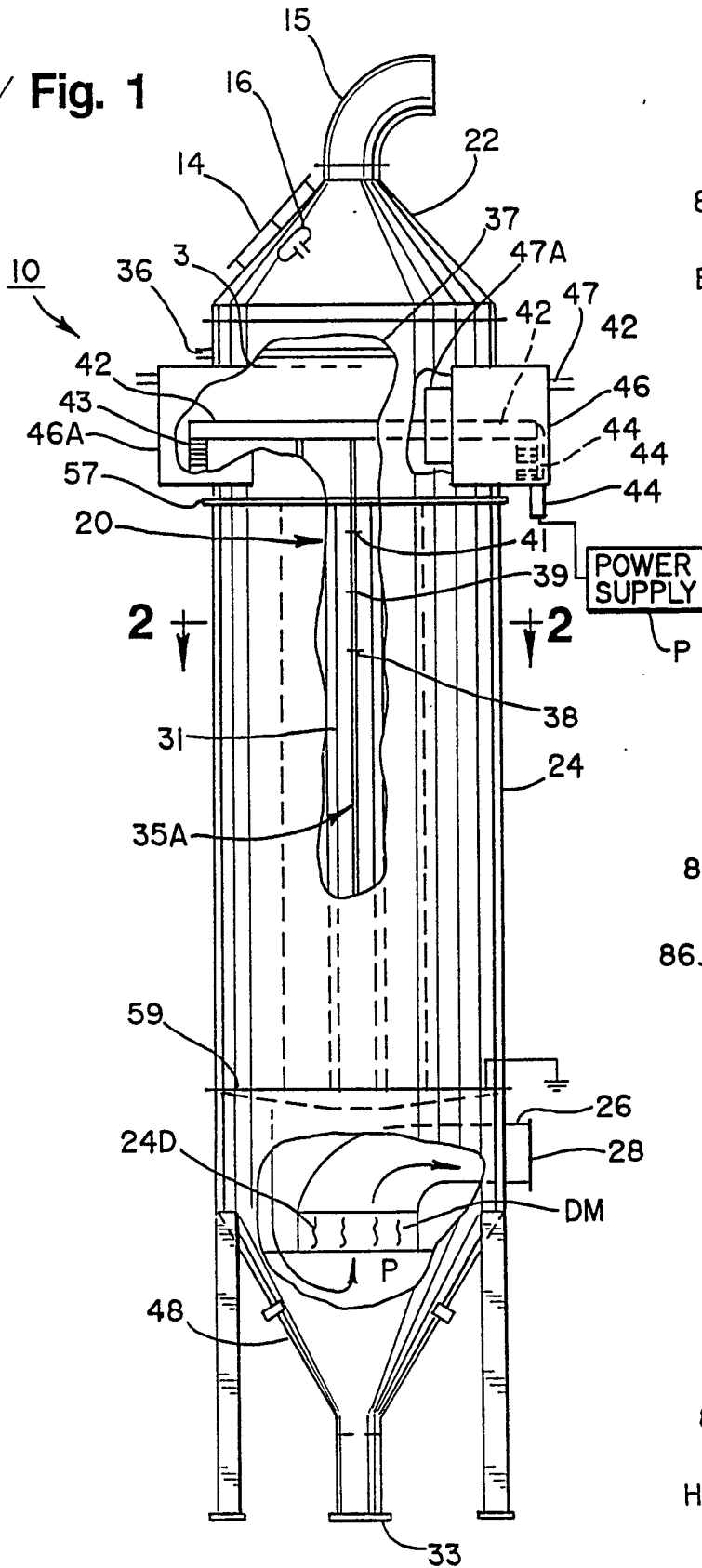

Fig. 4

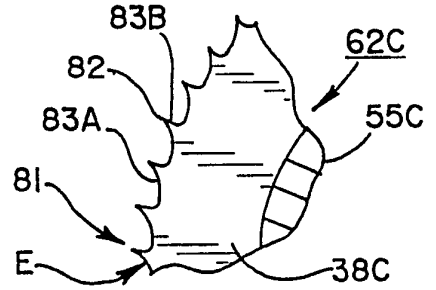

Fig. 5

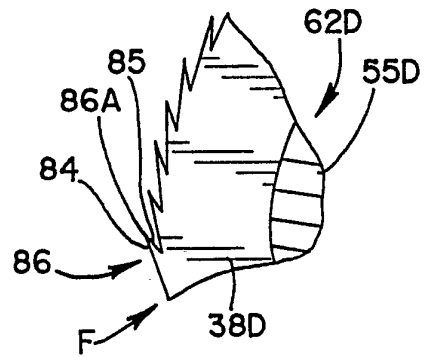
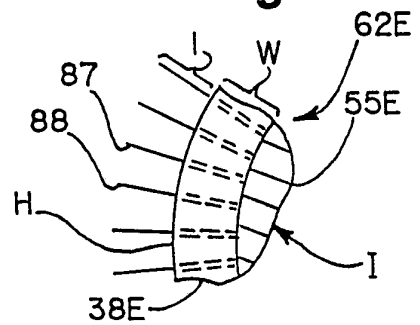

Fig. 6



2/3

Fig. 2

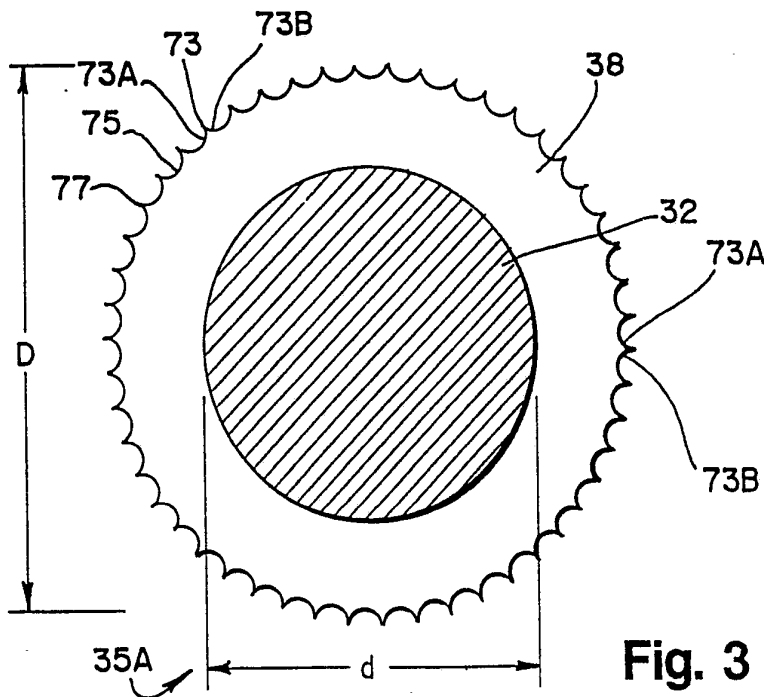
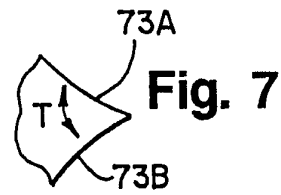
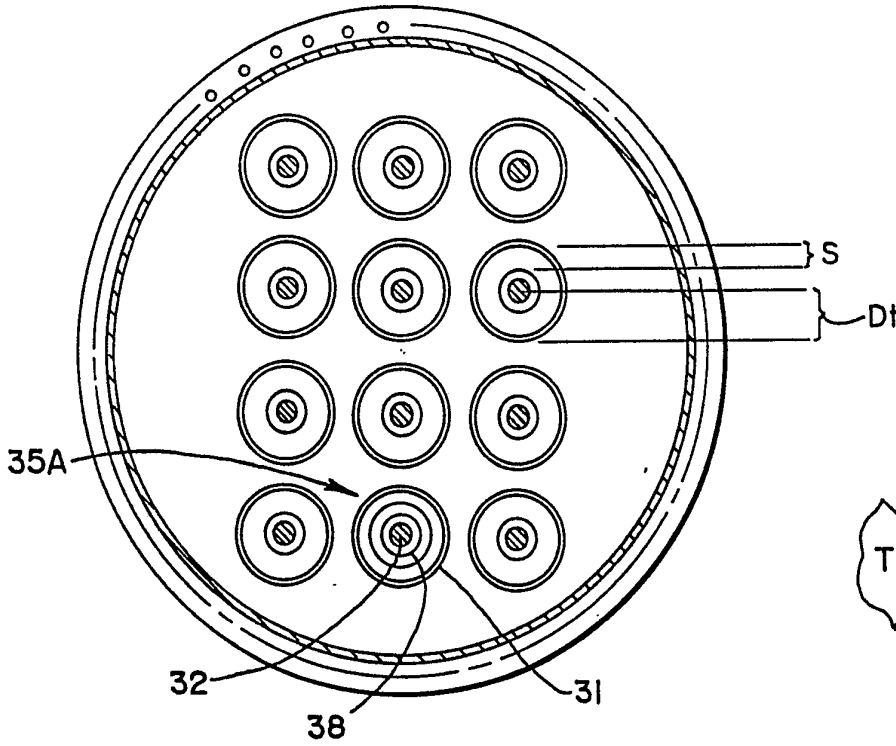

Fig. 3

3/3

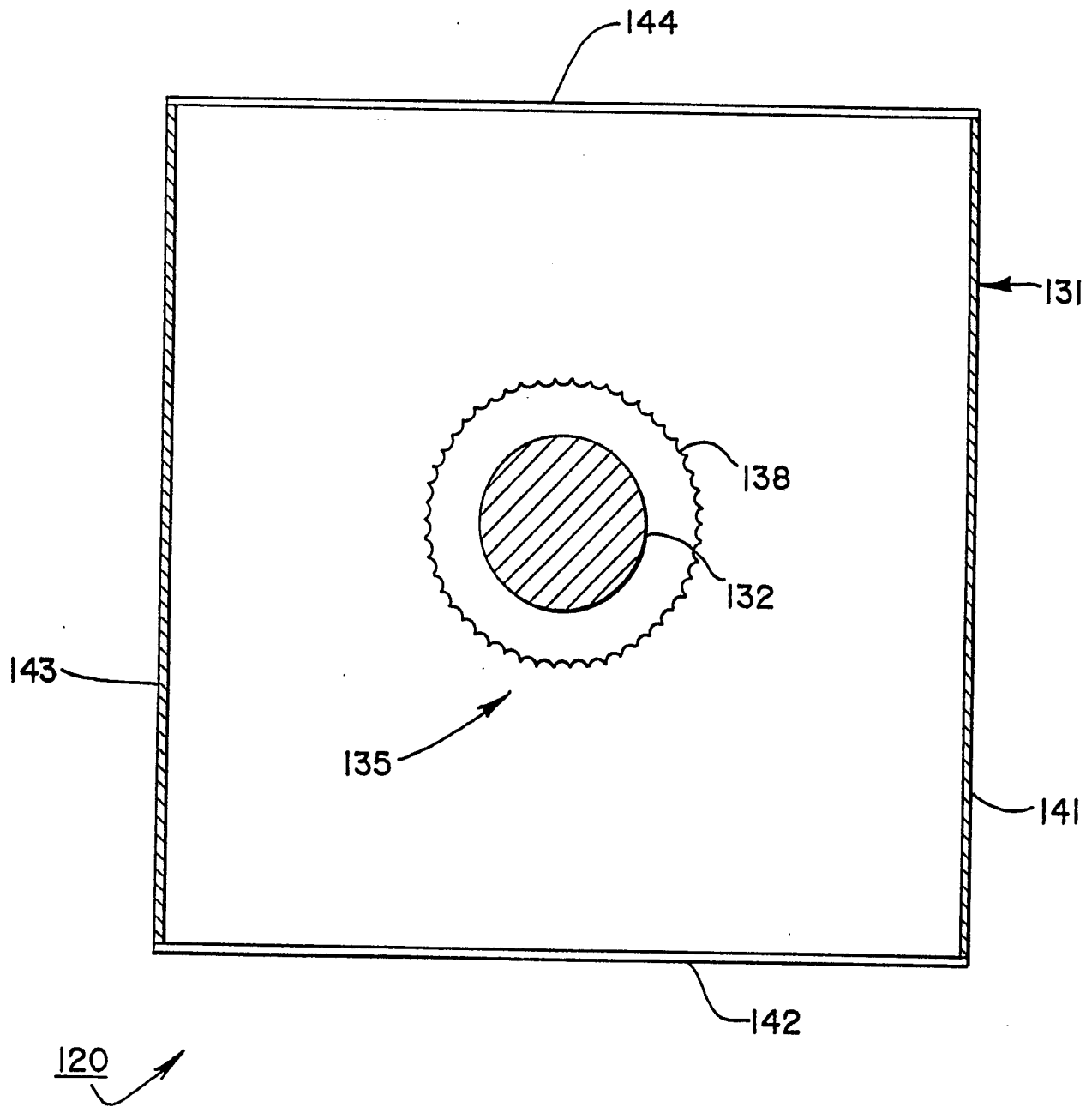

Fig.4A

INTERNATIONAL SEARCH REPORT

International application No.
PCT/US92/02999

A. CLASSIFICATION OF SUBJECT MATTER

IPC(5) :B03C 3/01
US CL :055/010

According to International Patent Classification (IPC) or to both national classification and IPC

B. FIELDS SEARCHED

Minimum documentation searched (classification system followed by classification symbols)

U.S. : 055/122, 146

Documentation searched other than minimum documentation to the extent that such documents are included in the fields searched

Electronic data base consulted during the international search (name of data base and, where practicable, search terms used)

C. DOCUMENTS CONSIDERED TO BE RELEVANT

Category*	Citation of document, with indication, where appropriate, of the relevant passages	Relevant to claim No.
X	US, A, 4,247,307 (CHANG) 27 January 1981, See figures 2 and 6a.	1-22
Y	US, A, 4,194,888 (SCHWAB ET AL) 25 March 1980, See column 4, lines 17-23.	1-22
Y	US, A, 4,389,225 (WILLETT ET AL) 21 June 1983, See column 2, lines 26-49.	1-22

Further documents are listed in the continuation of Box C. See patent family annex.

* Special categories of cited documents:	"T" later document published after the international filing date or priority date and not in conflict with the application but cited to understand the principle or theory underlying the invention
"A" document defining the general state of the art which is not considered to be part of particular relevance	"X" document of particular relevance; the claimed invention cannot be considered novel or cannot be considered to involve an inventive step when the document is taken alone
"E" earlier document published on or after the international filing date	"Y" document of particular relevance; the claimed invention cannot be considered to involve an inventive step when the document is combined with one or more other such documents, such combination being obvious to a person skilled in the art
"L" document which may throw doubts on priority claim(s) or which is cited to establish the publication date of another citation or other special reason (as specified)	"&" document member of the same patent family
"O" document referring to an oral disclosure, use, exhibition or other means	
"P" document published prior to the international filing date but later than the priority date claimed	

Date of the actual completion of the international search
30 JULY 1992

Date of mailing of the international search report
11 SEP 1992

Name and mailing address of the ISA/
Commissioner of Patents and Trademarks
Box PCT
Washington, D.C. 20231

Authorized officer

Bernard Nozick
BERNARD NOZICK

Facsimile No. NOT APPLICABLE

Telephone No. (703) 308-3792