

(No Model.)

A. B. HERRICK.
BUS BAR INSULATING SUPPORT.

No. 525,708.

Patented Sept. 11, 1894.

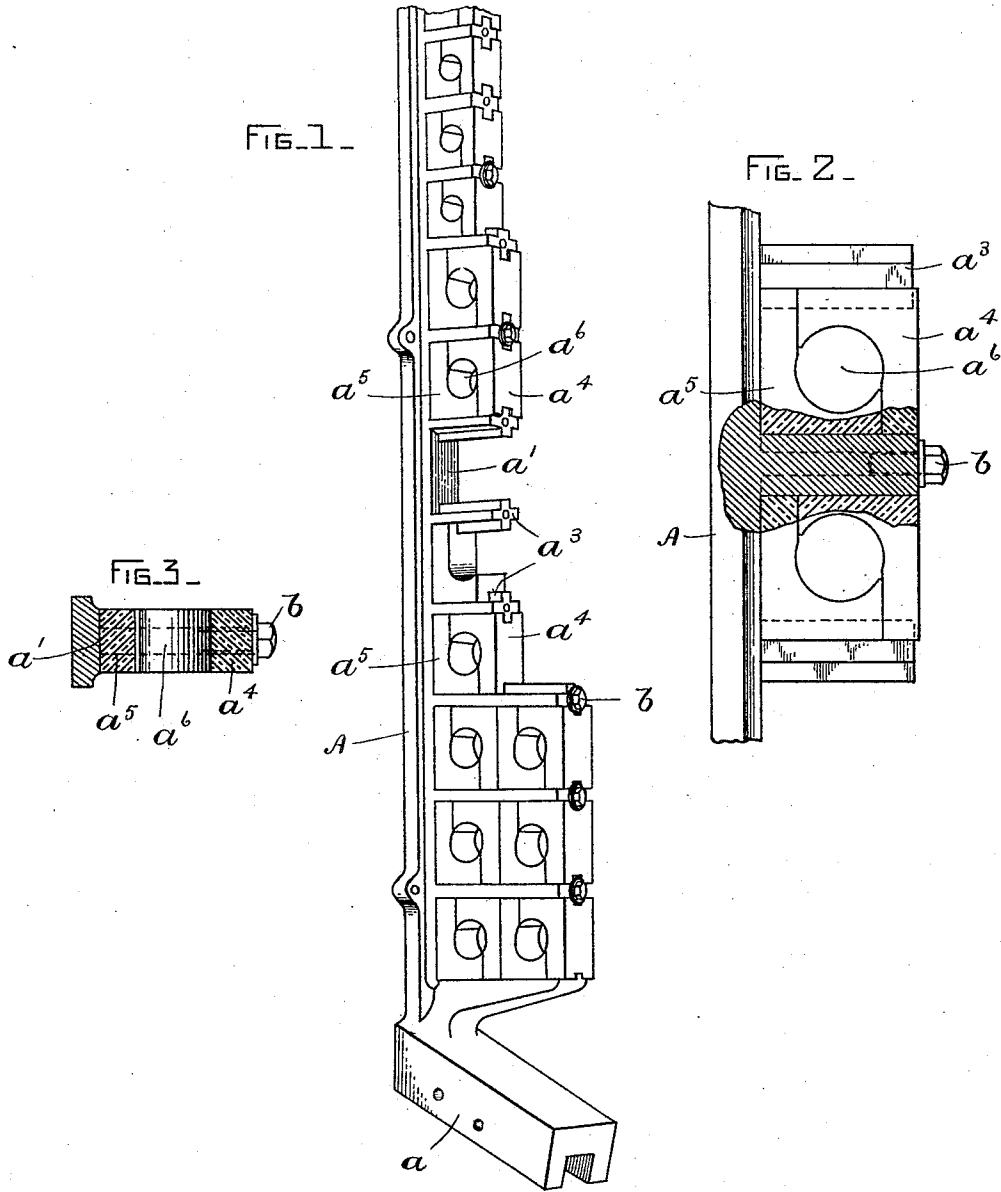

WITNESSES.

A. F. Macdonald.

J. Johnston

INVENTOR-

Albert B. Herrick

By Geo. R. Woodgett
Att'y.

UNITED STATES PATENT OFFICE.

ALBERT B. HERRICK, OF SCHENECTADY, NEW YORK, ASSIGNOR TO THE
GENERAL ELECTRIC COMPANY, OF NEW YORK.

BUS-BAR INSULATING-SUPPORT.

SPECIFICATION forming part of Letters Patent No. 525,708, dated September 11, 1894.

Application filed April 11, 1894. Serial No. 507 111. (No model.)

To all whom it may concern:

Be it known that I, ALBERT B. HERRICK, a citizen of the United States, residing at Schenectady, county of Schenectady, State of New York, have invented certain new and useful Improvements in Bus-Bar Insulating-Supports, of which the following is a specification.

My invention relates to an insulating frame or panel for supporting and insulating electric conductors, and is especially adapted for use with what are ordinarily known as bus-bars, which consist of heavy copper rods commonly used at the back of switch-boards, through which various connections are made between the dynamo or dynamos and the circuits fed thereby. Since these bus-bars are heavy it is necessary that they be furnished with a strong support, and a high degree of insulation is also desirable. The invention however, is not limited to the presence of bus-bars, but may be used with any kind of electric conductors.

My invention consists in a rack or frame of cast iron or other material of sufficient strength, in which are arranged insulating blocks made preferably of porcelain or other non-combustible insulating material, which are seated in guideways in the frame in such manner that they may be replaced with ease and permit the removal of any one conductor or set of conductors without disturbing the remaining conductors in any way. The insulating blocks are made in two parts, so shaped that they furnish openings to receive the conductor, and fastened to the frame in such manner that they may be removed independently.

In the accompanying drawings, Figure 1 is a perspective view of a rack embodying the invention. Fig. 2 shows a portion of the rack with certain parts shown in section, and Fig. 3 is a cross section through the center of one of the insulating blocks.

Referring to Fig. 1, the frame of the rack or panel consists of the casting A, so shaped as to fit against the side of a wall or other suitable support. At one end there is provided a supporting piece *a*, standing at an angle to the main portion of the frame, and which forms a leg to help support the rack. The main portion of the frame consists of a

panel or base-piece *a'*, from which project at suitable intervals stems *a³* of any desired length between which the insulating blocks are supported. These stems are shown in the shape of a cross so as to provide projecting tongues which fit into corresponding grooves on the sides of the insulating blocks, and form guide ways holding the blocks in place laterally. In lieu of the foregoing construction the stems may be formed with grooves and the blocks with tongues for the same purpose.

The insulating blocks are made in two parts. An inner part *a⁵*, which when in place fits down flat against the panel, is L-shaped so that the conductor will be received into the groove in this piece, and supported therein even though the top piece *a⁴* be removed. When the two parts *a⁴* and *a⁵* are in place they entirely surround the conductor which is not shown, but which it will be understood passes through a central opening *a⁶* formed by a transverse semi-circular groove in the inner face of the long and short arm of the L-shaped section. Preferably the two parts *a⁴*, *a⁵* will be made alike, so as to be interchangeable and requiring only a single mold for their manufacture. The rack bar may be made of any desired length and as many blocks be used as suit the requirements of a given plant. These blocks will be in some cases arranged in a single tier as shown at the top of Fig. 1, and in other cases they may be built up in two, three or any desired number of tiers, as shown at the bottom in Fig. 1. The blocks are held in place in the frame by bolts *b* having enlarged heads and screwing into the stems *a³*. It is not necessary that the blocks be made of the shape shown in the drawings and specially described herein, since various modifications are permissible, though still maintaining the principal object of the invention, which is to support and thoroughly insulate a desired number of conductors in such a way that each one may be removed independently for repairs or other purposes.

What I claim as new, and desire to secure by Letters Patent of the United States, is—

1. A new article of manufacture consisting of an L-shaped section for an insulating block formed with a transverse passage way for a

conductor on the inner face of the long and short arm of the L-shaped piece, and with means on the outer face for securing the section in a frame.

5 2. As a new article of manufacture, a section of an insulating block formed of an L-shape having a semi-circular groove in its inner face both in the long and short arm of the L-shaped piece and extending transversely
10 thereto, and having a groove on its outer face to secure it in a frame.

3. As a new article of manufacture, a block of insulating material, formed of counterpart L-shaped sections, having a transverse
15 passage way on the inner face of each section both in the long and short arm thereof and fitting the opposite section to form a passage way for a conductor, and means on the exterior of each section for securing the sections
20 independently to a frame.

4. An insulating support for electric conductors, comprising L-shaped porcelain pieces adapted when placed together to surround a conductor, such as a bus-bar, grooves
25 in the sides of said L-shaped piece adapted

to register when the pieces are placed together, a rack having a series of stems adapted to support said pieces, projections from said stems adapted to fit the grooves, and means for securing the said pieces in place, as set forth. 30

5. A bus-bar support and insulator, comprising pieces of porcelain adapted when placed together in pairs to form rectangular blocks with central openings for the bus-bars, longitudinal grooves in the sides of said pieces adapted to register when the blocks are placed together, a rack or frame having a flat base portion forming a seat for said blocks, stems projecting therefrom between which said
35 blocks are supported, guides or projections on said stems to fit said grooves, and fasteners at the tops of the stems projecting over the blocks to hold them in place, as set forth. 40

In witness whereof I have hereunto set my hand this 10th day of April, 1894. 45

ALBERT B. HERRICK.

Witnesses:

B. B. HULL,
C. L. HAYNES.