

(No Model.)

2 Sheets—Sheet 1.

G. W. CROSS.
REVOLVING COAL SCREEN.

No. 524,577.

Patented Aug. 14, 1894.

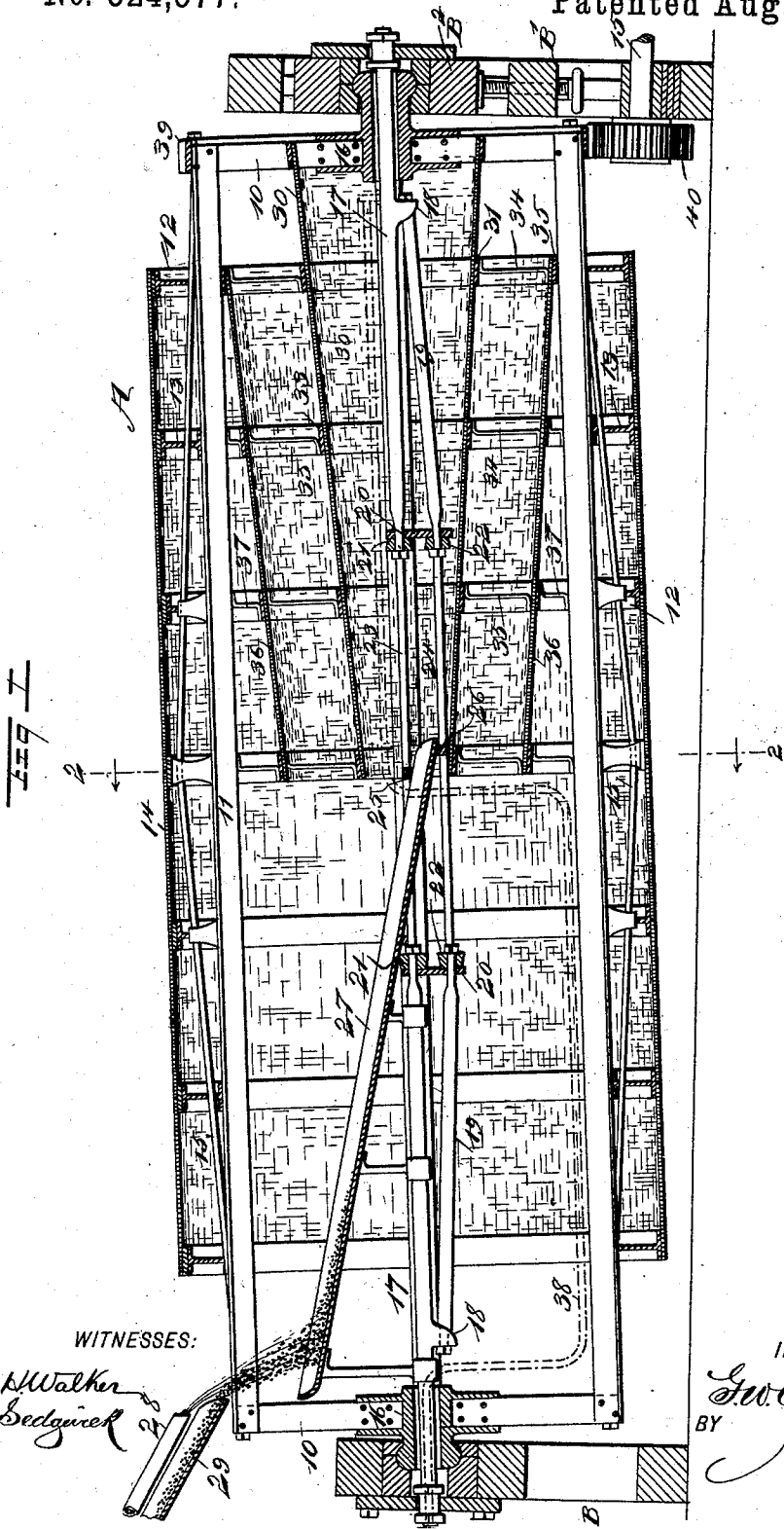

WITNESSES:

R. Walker
C. Sedgwick

INVENTOR

G. W. Cross
BY
Munn & Co
ATTORNEYS.

(No Model.)

2 Sheets—Sheet 2.

G. W. CROSS.
REVOLVING COAL SCREEN.

No. 524,577.

Patented Aug. 14, 1894.

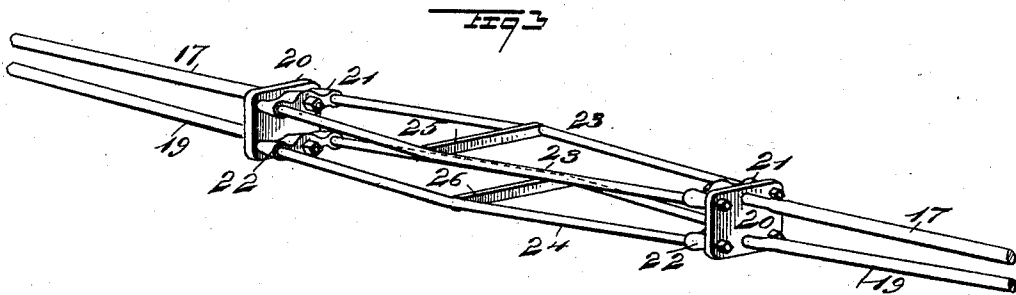
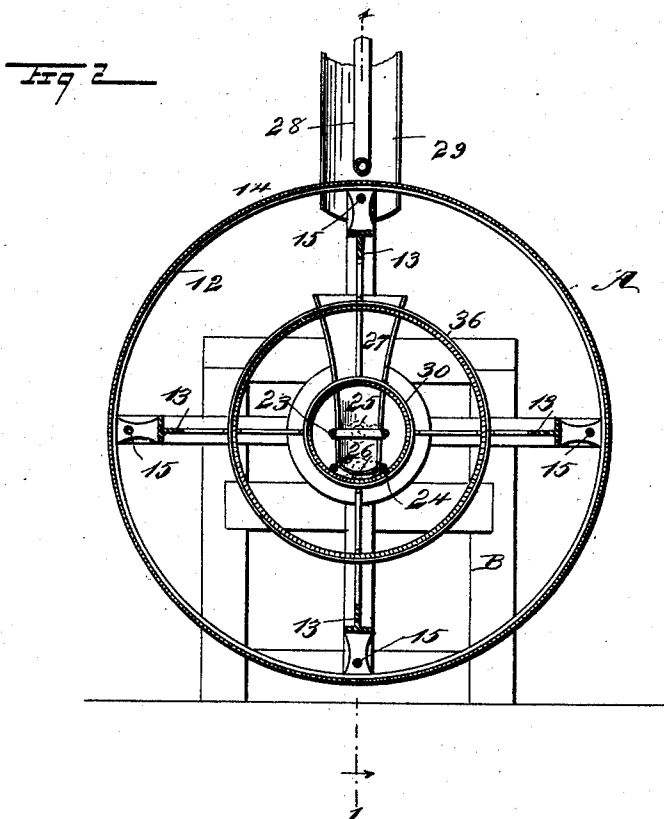

WITNESSES:

H. Walker
C. Sedgwick

INVENTOR

G. W. Cross
BY *Munn & Co*

ATTORNEYS.

UNITED STATES PATENT OFFICE.

GEORGE W. CROSS, OF PITTSBURGH, PENNSYLVANIA.

REVOLVING COAL-SCREEN.

SPECIFICATION forming part of Letters Patent No. 524,577, dated August 14, 1894.

Application filed January 10, 1894. Serial No. 496,373. (No model.)

To all whom it may concern:

Be it known that I, GEORGE W. CROSS, of Pittston, in the county of Luzerne and State of Pennsylvania, have invented a new and Improved Revolving Coal-Screen, of which the following is a full, clear, and exact description.

My invention relates to a revolving screen especially adapted for screening coal, and it has for its object to provide a screen in which the coal will be received for screening at its elevated end, and whereby the coal will be divided into sizes, the stove or nut coal being delivered, for example, at the elevated end of the screen, while the pea-coal or screenings will be delivered at the lower end of the screen.

A further object of the invention is to provide a convenient means for feeding the coal and water into the screen.

The invention consists in the novel construction and combination of the several parts, as will be hereinafter fully set forth and pointed out in the claims.

Reference is to be had to the accompanying drawings, forming a part of this specification, in which similar figures and letters of reference indicate corresponding parts in all the views.

Figure 1 is a longitudinal vertical section through the improved screen, the said section being taken practically on the line 1—1 of Fig. 2. Fig. 2 is a transverse section taken essentially on the line 2—2 of Fig. 1; and Fig. 3 is a detail perspective view of the truss support located in the screen and adapted to sustain the chute or feed trough.

In carrying out the invention the screen A, is mounted to turn in two bulk-heads B and B', one of the bulk-heads being provided with an adjustable bearing block B², whereby one end of the screen may be given any desired inclination, while the bearing at the opposite end has a rocking connection with its support, which will enable the adjustable end to be readily raised or lowered without straining the pivotal end.

The screen A, is provided with a frame, and the said frame comprises end rings or heads 10, which are open, and series of angle irons 11, or other form of beams, which connect the two heads. The heads 10 and their con-

necting beams 11 constitute the main portion of the frame of the screen; the other portion of the frame consists of a series of rings or bands 12, of greater diameter than the diameter of the frame, the said auxiliary rings or bands being all of equal diameter, and they are supported preferably upon the longitudinal beams 11 of the frame by means of blocks 13, preferably in the nature of I-irons. The auxiliary bands or rings 12 commence a predetermined distance from each head of the main frame, and the auxiliary bands or rings are adapted to support a screening material 14, through which the fine dust of the coal is adapted to be sifted, the screening material being of sufficiently fine mesh to retain the pea-coal, or particles practically of that size.

The auxiliary bands or rings 12, are supported through the medium of truss rods 15, which are secured to the longitudinal beams 11 of the main frame, and are passed through the blocks 13 sustaining said bands, as is shown in Figs. 1 and 2. The head of each frame is provided with a central tubular bearing 16, and the outer ends of these bearings are of somewhat of a cylindrical formation, and fit in like cavities formed in the supports intended for them. Thus it will be observed that between the bearings 16 and their supports a substantially ball and socket connection is obtained.

A main rod 17, is passed from the outside into the frame of the screen through the tubular bearings 16, and near the inner end of each bearing 16 each rod 17 is preferably provided with an extension 18 at right angles to the body of the rod. The rods 17 are brace rods, and a second rod 19 is secured to each extension 18 of the main rods, the second or branch rods 19, being made to extend inwardly below the main rods and to diverge therefrom at their inner ends. The inner ends of each of the main rods and branch rods are secured by means of bolts or otherwise to plates 20, and each rod passes through a cross head located upon the inner face of each plate. These two cross heads are held in engagement with each plate 20, and are designated as 21 and 22, as is best shown in Fig. 3.

Each horizontally opposing set of cross heads is connected by truss rods projecting

from each end, the upper set of truss rods being designated as 23 and the lower set as 24; and each set of truss rods is made to diverge at the center, and is connected at the central portions by cross bars, the upper cross bar being designated as 25 and the lower cross bar as 26.

The upper brace rods 17 at the inclined end of the screen, since one end of the screen is raised higher than the other end, is adapted to support primarily a delivery chute or trough 27, in which the coal is entered at the open space between the lower end of the main frame of the screen and the corresponding end of the screen or sieve portion 14 thereof, and water or other fluid is likewise delivered with the coal to the trough 27 through the medium of a supply pipe 28, which is located immediately above the chute 29, adapted to conduct the coal from the bin, or the receptacle in which it may be stored or emptied.

The trough 27, supported by the brace rods 17, is elevated at its receiving end and depressed at its delivery end, and extends practically from one end of the screen to the center thereof, being made to rest at its delivery end upon the lower cross bar 26 of the truss structure shown in Fig. 3, the upper cross bar 25, extending over the top of the trough, as shown in Fig. 1. The trough delivers its contents into a sub-trough 30, which is shaped substantially as the frustum of a cone, the chute entering its contracted end, while the sub-screen 30 at its wider end is secured to the head 10 of the main frame at the elevated end thereof; the body portion of the screen being attached to bands 31, which are connected in any approved manner, usually by means of braces 34 with concentric and larger bands 35, the said concentric and larger bands being adapted as supports for a second and concentric sub-screen 36, of greater diameter yet of the same shape as the inner or central sub-screen; and the outer bands 35, are connected with the longitudinal bars or beams 11 of the frame by means of braces 37, or the equivalents thereof. In this manner two conical screens are held at the elevated end of the main screen to revolve therewith, but the outer of the two conical screens extends only as far as the outer edge of the band 12 of the main screen, located at the elevated end thereof. Thus, although the main screen is given a decided pitch in one direction, the conical formation of the sub-screens impart to them a pitch in a contrary direction, and the two sub-screens are of different mesh. All of the coal, water, &c., from the chute 27, is received by the inner conical screen, which, for example, is of such mesh as to retain within it coal of a stove size, which coal will be delivered from the said inner conical screen through the head 10 at the elevated end of the screen, while the nut size will drop through the meshes of the inner screen and will fall upon the outer of the two conical screens, and will find an exit at the elevated end of the

main screening surface 14 of the screen, while the pea-coal, or tailings of the coal will fall down upon the main or outer screening surface 14 and will follow the inclination thereof, being delivered at its lower end, while the fine trash and water will pass through the meshes of the main or outer screening surface 14 to the surface beneath said screen.

In order that water may be supplied to the pea-coal as it finds an exit from the screen, a perforated water-delivery pipe 38, is made to enter through one of the tubular trunnions, as shown in dotted lines in Fig. 1, and the said pipe is carried downward so as to be a predetermined distance from the main screening surface, and is ordinarily carried upward and made to terminate over the fixed braces at the elevated end of the screen. In this manner a rapid and perfect separation and cleaning of the coal is secured, the refuse being delivered at one end while the graded or separated coal is delivered independently at the opposite end, the said end being the elevated end of the screen.

The screen may be revolved in various ways. In the drawings it is shown as provided at its elevated head with exterior teeth 39, which are engaged by a gear 40, located upon the drive shaft 15 journaled in the bulk-head B'.

Having thus described my invention, I claim as new and desire to secure by Letters Patent—

1. A screen, the same consisting of a frame, open at its ends, an outer screening surface carried by the frame and terminating short of the extremities of the frame, conical screens located within the outer screen, and extending from a point near the center longitudinally within the frame of the screen, the contracted ends of the inner screens being their inner ends, the enlarged end of one inner screen terminating at the end of the outer screen, while the corresponding end of another of the inner screens extends out to the head of the frame, and a chute projecting into the contracted end of the innermost screen substantially as shown and described.

2. In a screen, the combination, with a frame, supports for the frame and an adjusting mechanism engaging with one end of the frame, whereby said end is held in an elevated position, and an outer screen open at its ends, carried by the frame and stopped short of the extremities of the latter, of conical screens located within the frame and connected therewith, one inner screen being within the other, the inner ends of the conical screens being the contracted portions, one of the screens extending at its larger end to the elevated end of the outer screen, while the corresponding end of the inner of the conical screens is carried to the elevated end of the frame, and a stationary chute permanently located within the screen, its delivery end entering the contracted end of the innermost screen, its receiving end being without the

outer screen at the lower end thereof, substantially as and for the purpose set forth.

3. In a screen, the combination, with a frame, supports for the frame and an adjusting mechanism engaging with one end of the frame, whereby said end is held in an elevated position, and an outer screen open at its ends, carried by the frame and stopped short of the extremities of the latter, of conical screens located within the frame and connected therewith, one inner screen being within the other, the inner ends of the conical screens being the contracted portions, one of the screens extending at its larger end to the elevated end of the outer screen, while the corresponding end of the inner of the conical screens is carried to the elevated end of the frame, a stationary chute permanently located within the screen, its delivery end entering the inner conical screen, its receiving end being without the outer screen at the lower end thereof, and a truss frame projected through the end bearings of the heads of the screen frame, the truss frame serving to support the chute within the screen, substantially as shown and described.

4. In a screen, the combination, with a frame, supports for the frame and an adjusting mechanism engaging with one end of the frame, whereby said end is held in an elevated position, and an outer screen open at its ends, carried by the frame and stopped short of the extremities of the latter, of conical screens located within the frame and connected therewith, one inner screen being within the other, the inner ends of the conical screens being the contracted portions, one of the screens extending at its larger end to the elevated end of the outer screen, while the corresponding end of the inner of the conical

screens is carried to the elevated end of the frame, a stationary chute permanently located within the screen, its delivery end entering the inner conical screen, its receiving end being without the outer screen at the lower end thereof, a truss frame projected through the end bearings of the heads of the screen frame, the truss frame serving to support the chute within the screen, and a spray pipe stationarily located within the outer screen and extending from the inner screens to the lower end of the outer screen, substantially as shown and described.

5. The combination with a revolving screen embracing an outer, inclined cylindrical screen having an outlet at its lower end, and inner conical screens having independent outlets at the higher end of the outer screen, of a stationary chute entering the outer screen at its lower end and extending within the inner conical screens, and adapted to supply water and minerals thereto, and a stationary spray pipe extending from the inner screens to the delivery end of the outer screen, as and for the purpose specified.

6. In a screen, the combination with supports and a screen frame mounted in the supports and provided with hollow bearings, of a truss frame, comprising main rods projecting through the hollow bearings, branch rods secured to the main rods, cross heads to which the main and branch rods are secured, truss rods connecting the cross heads, and cross bars connecting the truss rods at their centers, substantially as herein shown and described.

GEORGE W. CROSS.

Witnesses:

W. M. BERRY,
W. A. ALLEN.