



PATENT SPECIFICATION

(11) S85672

(21) Application No. S2009/0827

(22) Date of Filing of Application: 28/10/2009

(30) Priority Data:

(31) S2008/0873 (32) 28/10/2008 (33) Ireland (IE)

(45) Specification Published: 05 January 2011

(51) Int. Cl. (2009)
 E04H 17/26

(54) Title: A post driver

(72) Inventor: JOSEPH ANTHONY BRENNAN
 MICHAEL RICHARD BRENNAN

(73) Patent Granted to: JOSEPH ANTHONY BRENNAN, An Irish Citizen, Crosspatrick
 Johnstown Co. Kilkenny, Ireland
 MICHAEL RICHARD BRENNAN, An Irish Citizen, Bawnmore Road
 Johnstown Co. Kilkenny, Ireland

A Post Driver**Introduction**

5

This invention relates to post drivers, in particular for mounting on digger vehicles, tractors and the like.

10

The invention is particularly concerned with post drivers of the type having a mast with a hammer mounted on the mast which is operable for driving a post into the ground and a post cap mounted on the mast below the hammer for engaging a top of the post as the hammer drives the post into the ground.

15

It is an object of the present invention to provide an improved post driver of this type.

Summary of the Invention

According to the invention there is provided a post driver including:

20

a mast,

a hammer mounted on the mast and being operable for driving a post into the ground,

25

a post cap mounted on the mast below the hammer,

characterised in that stop means is provided for limiting upward movement of the post cap on the mast.

30

Preferably the post driver has means for mounting the mast on a tractor vehicle and means for raising the hammer on the mast for release to drive a post into the ground.

In a particularly preferred embodiment of the invention the post driver includes:

means for mounting the mast on a tractor vehicle,

5 the hammer is slideably mounted on the mast for movement between a raised position and a lowered position on the mast,

means for raising the hammer from the lowered position to the raised position for release to drive a post into the ground,

10 the post cap is slideably mounted on the mast beneath the hammer and moveable between a raised position and a lowered position on the mast,

the stop means is provided on the mast for limiting upward movement of the post cap on the mast.

15

In another embodiment the stop means is adjustable for adjustment of the allowable upward movement of the post cap on the mast.

20 In another embodiment the stop means is a stop element mounted spaced-apart from a bottom of the mast.

Conveniently the stop means may be provided with a resilient face for engagement with the post cap.

25 In a further embodiment bias means is provided for urging the post cap towards the bottom of the mast.

In another embodiment the bias means is a spring engaged between the post cap and the mast.

30

In a preferred embodiment the mast is of I-section having an outer flange and an inner flange which are substantially parallel and spaced-apart, being interconnected by an intermediate web, the hammer is slideably mounted on the outer flange, the post cap is slidably mounted on the mast and extends rearwardly of the outer flange

for engagement with the stop which is mounted on or adjacent the inner flange.

In a further embodiment the post cap has a collar which slideably engages around the mast for slideably mounting the post cap on the mast.

5

In another embodiment a mounting frame for mounting the post driver on the tractor vehicle is attached to the mast and the stop is on the mounting frame.

10 In another embodiment the mounting frame includes a support plate mounted on the inner flange and protecting outwardly therefrom, an arm on the support plate carrying a connector element for attachment to a tractor vehicle.

In another embodiment the mounting frame has means for attachment to a three-point linkage on a tractor vehicle.

15

In another embodiment the stop means is a chain mounted between the mast and the post cap.

20 Conveniently the chain is attached to the mast at a lower end of the inner flange. A pair of chains may be provided connected between the post cap and the inner flange at either side of the web.

In another embodiment the post cap is slidably mounted on the outer flange of the mast.

25

Brief Description of the Drawings

30 The invention will be more clearly understood by the following description of some embodiments thereof, given by way of example only, with reference to the accompanying drawings in which;

Fig. 1 is a perspective view of a post driver according to the invention;

Fig. 2 is another perspective view of the post driver;

Fig. 3 is a further perspective view of the post driver;

Fig. 4 is a perspective view of the post driver;

5

Fig. 5 is an elevational view of the post driver;

Fig. 6 is an enlarged detail perspective view showing portion of the post driver;
and

10

Fig. 7 is an elevational view of another post driver according to a second embodiment of the invention.

Detailed Description of Preferred Embodiments

15

Referring to the drawings, and initially to Figs. 1 to 6 thereof, there is illustrated a post driver according to the invention indicated generally by the reference numeral 1. The post driver 1 has an upright mast 2. A hammer 3 is slideably mounted on the mast 2 and is operable for driving a post into the ground. A post cap 4 is slideably mounted on the mast 2 below the hammer 3. A stop element 5 is provided for limiting upward movement of the post cap 4 on the mast 2.

20

The mast 2 is of I-Section having an outer flange 8 and an inner flange 9 which are substantially parallel and spaced-apart and joined by an intermediate web 10 which is perpendicular to the flanges 8, 9. The hammer 3 is slideably mounted on the outer flange 8 for movement between a raised position and a lowered position on the mast 2.

25

A rope 7 or cable is operable for raising the hammer 3 from the lowered position to the raised position for release to drive a post into the ground. The rope 7 is attached at one end to an anchor point 11 on the hammer 3 and extends upwardly around a fixed pulley 12 rotatably mounted at a top of the mast 2, down around a moveable pulley 14 rotatably mounted on a carriage 15 slideably mounted on the inner flange 9 and then upwardly to a fixed anchor point 16 at a top of the mast 2. A ram 18 is

30

operable to pull the carriage 15 downwardly in order to raise the hammer 3. This type of hammer actuating mechanism has already been described in our European Patent Application No. 08150985.3 and thus requires no further elaboration here.

5 The post cap 4 has a collar 20 at its inner end which slideably engages around the mast 2, sliding along the outer flange 8 and inner flange 9. A land 21 at an inner end of the post cap 4 is engageable with the stop element 5.

10 A mounting frame 25 for mounting the post driver 1 on a tractor vehicle is attached to the mast 2. The mounting frame 25 comprises a pair of support plates 26, 27 mounted on the inner flange 9 of the mast 2 and projecting rearwardly therefrom. A laterally projecting arm 28 on one of the support plates 26 carries a connector element 29 for attachment to a tractor vehicle. In this case the connector element 29 is an excavator hitch for attachment to a digger vehicle.

15 A flanged inner end 30 of the arm 29 is bolted to the support plate 26. Mounting holes 32 are provided in both support plates 26, 27 so that the arm 28 can be mounted on either support plate 26, 27. Ram mounting holes 34 are also provided in the support plates 26, 27 to which a lower end of the ram 18 is attached for mounting
20 the ram 18 between the support plates 26, 27 and the carriage 15.

Cut-out slots 37 at an inner end of each support plate 26, 27 allow upward movement of the collar 20 of the post cap 4 for engagement with the stop element 5 which is located at an inner (upper) end of the slots 37.

25 In use, the post driver 1 is mounted on a digger vehicle by means of the connector element 29. The mast 2 is raised and then an underside of the post cap 4 is engaged with a top of a post to be driven into the ground. The mast 2 is lowered and the post cap 4 slides up the mast 2 until it engages against the stop 5. The weight of
30 the post driver 1 is now acting on the post to hold the post securely. Additional force can be applied by the arm of the excavator vehicle to which the post driver 1 is attached if desired. The hammer 3 can then be raised and dropped onto the post cap 4 in the usual way for driving the post into the ground. If desired during the driving operation the mast 2 may be lowered to keep the post cap 4 positively

engaged against the top of the post during hammering of the post into the ground.

In the embodiment shown in the drawings the stop element 5 is conveniently mounted on the support plates 26, 27. It will be appreciated however that the stop
5 element 5 could be mounted on the mast 2, on the inner flange 9 or possibly the web 10 so long as it does not foul sliding movement of the hammer 3 on the mast 2.

Various other arrangements are possible for limiting upward movement of the post cap in order to use the post cap to apply a downward force to a post being driven into
10 the ground.

It is also envisaged that provision may be made for adjustment of the spacing between a lower end of the mast 2 and the stop element 5.

15 Referring now to Fig. 7 there is illustrated another post driver indicated generally by the reference numeral 40. Parts similar to those described previously are assigned the same reference numerals. In this case instead of the bump stop element 5 shown in the previous embodiment, upward movement of the post cap 4 is limited by
20 a chain 41 mounted between the inner flange 9, at a lower end thereof, and the post cap 4. Thus as the post cap 4 rises on the mast 2 the chain 41 becomes taut to limit upward movement of the post cap 4. A pair of chains 41 may be mounted between each side of the post cap 4 and the inner flange 9 of the mast 2 at either side of the
25 web 10. Instead of a chain 41 a cable or similar restrainer could be used. It will be noted also in this case the post cap 4 is slidably mounted on the outer flange 8 of the mast 2.

The invention is not limited to the embodiments hereinbefore described which may be varied in both construction and detail within the scope of the appended claims.

CLAIMS

1. A post driver (1) including:

5 a mast (2),

a hammer (3) mounted on the mast (2) and being operable for driving a post into the ground,

10 a post cap (4) mounted on the mast (2) below the hammer,

characterised in that stop means (5) is provided for limiting upward movement of the post cap (4) on the mast (2).

15 2. The post driver (1) as claimed in claim 1 wherein the post driver (1) includes:

means (25) for mounting the mast (2) on a tractor vehicle,

20 the hammer (3) is slidably mounted on the mast (2) for movement between a raised position and a lowered position on the mast (2),

means (18) for raising the hammer (3) from the lowered position to the raised position for release to drive a post into the ground,

25 the post cap (4) is slidably mounted on the mast (2) beneath the hammer (3) and moveable between a raised position and a lowered position on the mast (2),

30 the stop means (5) is provided on the mast (2) for limiting upward movement of the post cap (4) on the mast (2).

3. The post driver (1) as claimed as claimed in any preceding claim the stop means is a stop element (5) mounted spaced-apart from a bottom of the mast (2), the stop means (5) being provided with a resilient face for engagement with

the post cap (4).

- 5
4. The post driver (1) as claimed in any preceding claim wherein the mast (2) is of I-section having an outer flange (8) and an inner flange (9) which are substantially parallel and spaced-apart, being interconnected by an intermediate web (10), the hammer (3) is slidably mounted on the outer flange (8), the post cap (4) is slidably mounted on the mast (2) and extends rearwardly of the outer flange (8) for engagement with the stop (5) which is mounted on or adjacent the inner flange (9), the post cap (4) having a collar (20) which slidably engages around the mast (2) for slidably mounting the post cap (4) on the mast (2).
- 10
5. A post driver substantially as hereinbefore described with reference to the accompanying drawings.
- 15

1/7

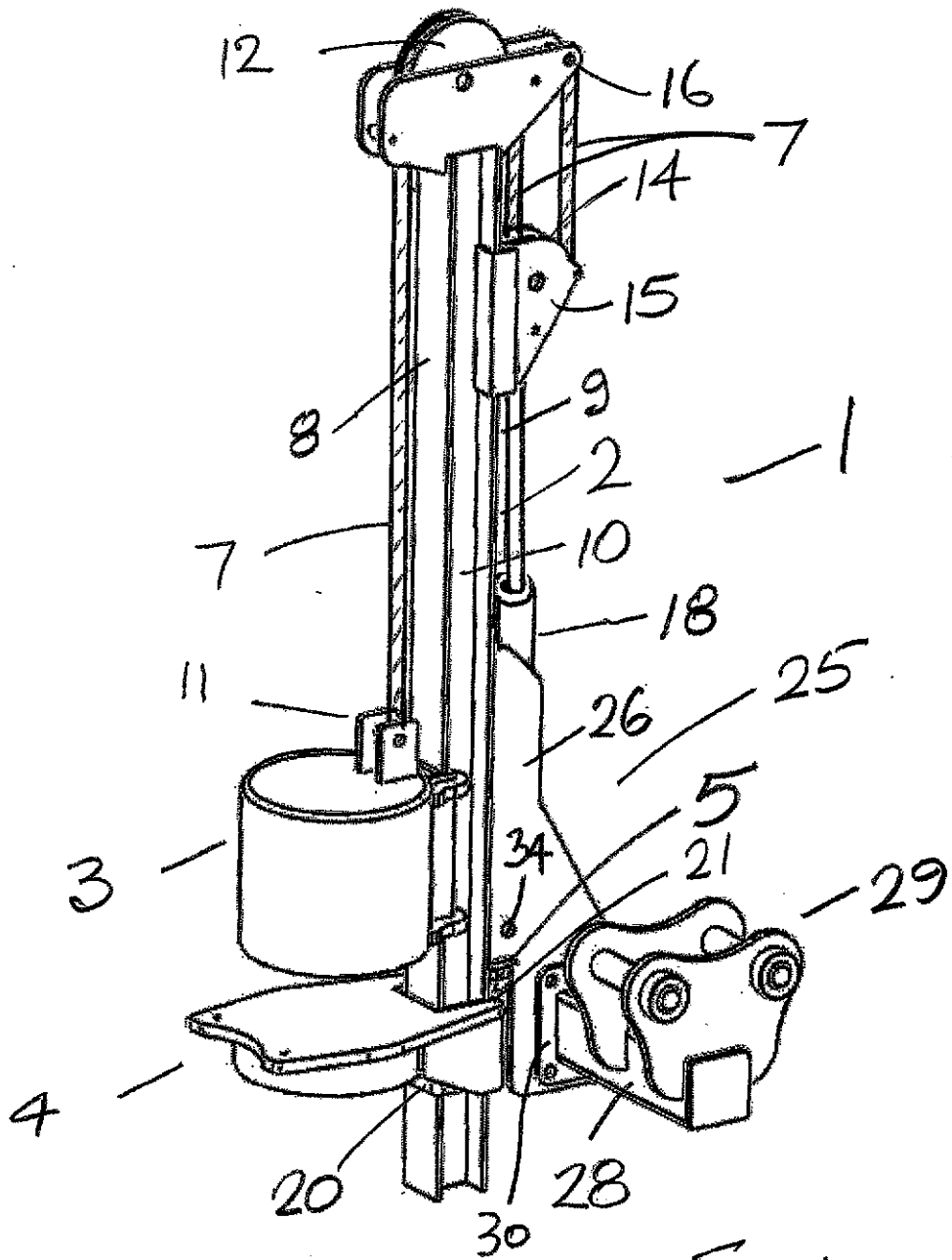

FIG 1

2/7

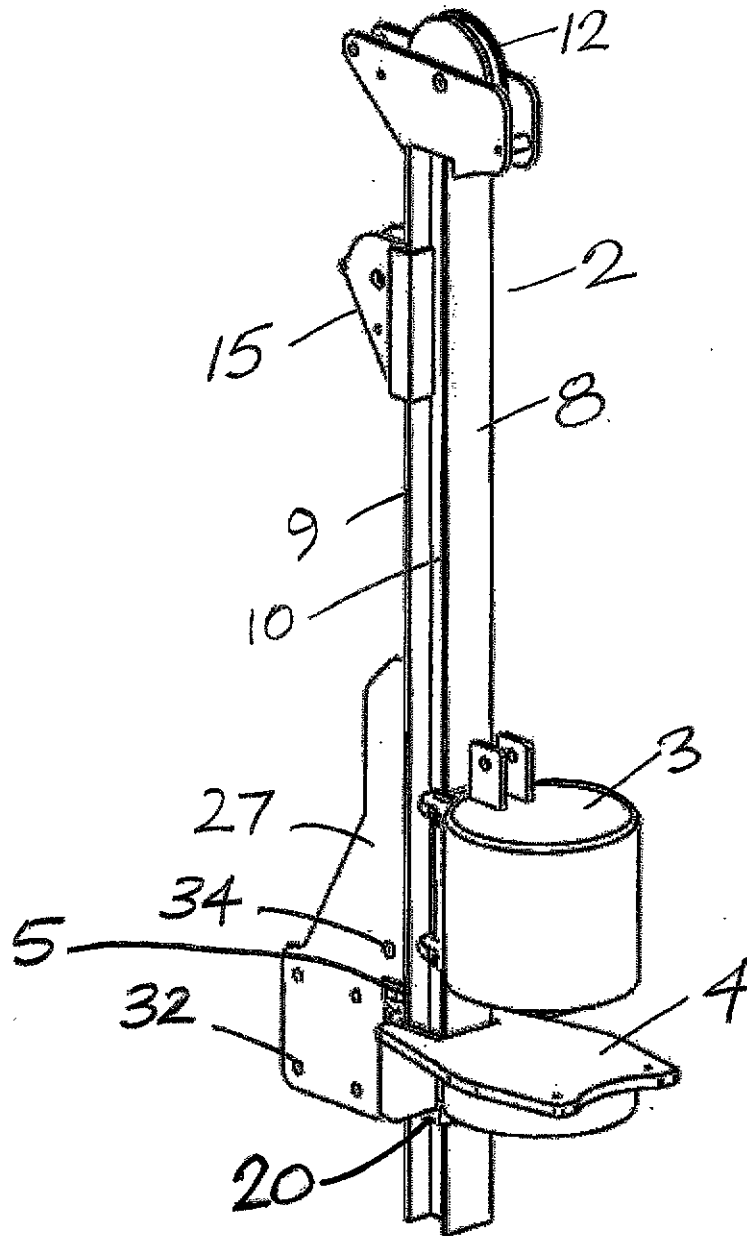

FIG 2

3/7

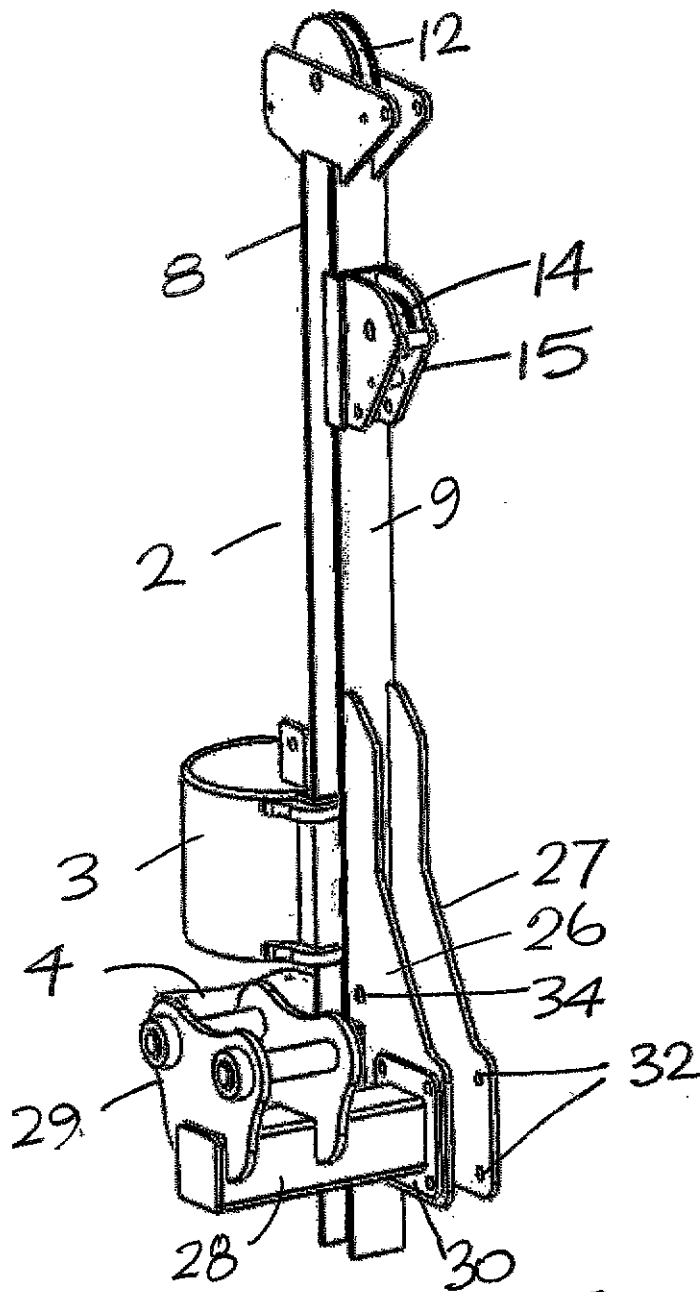

FIG 3

4/7

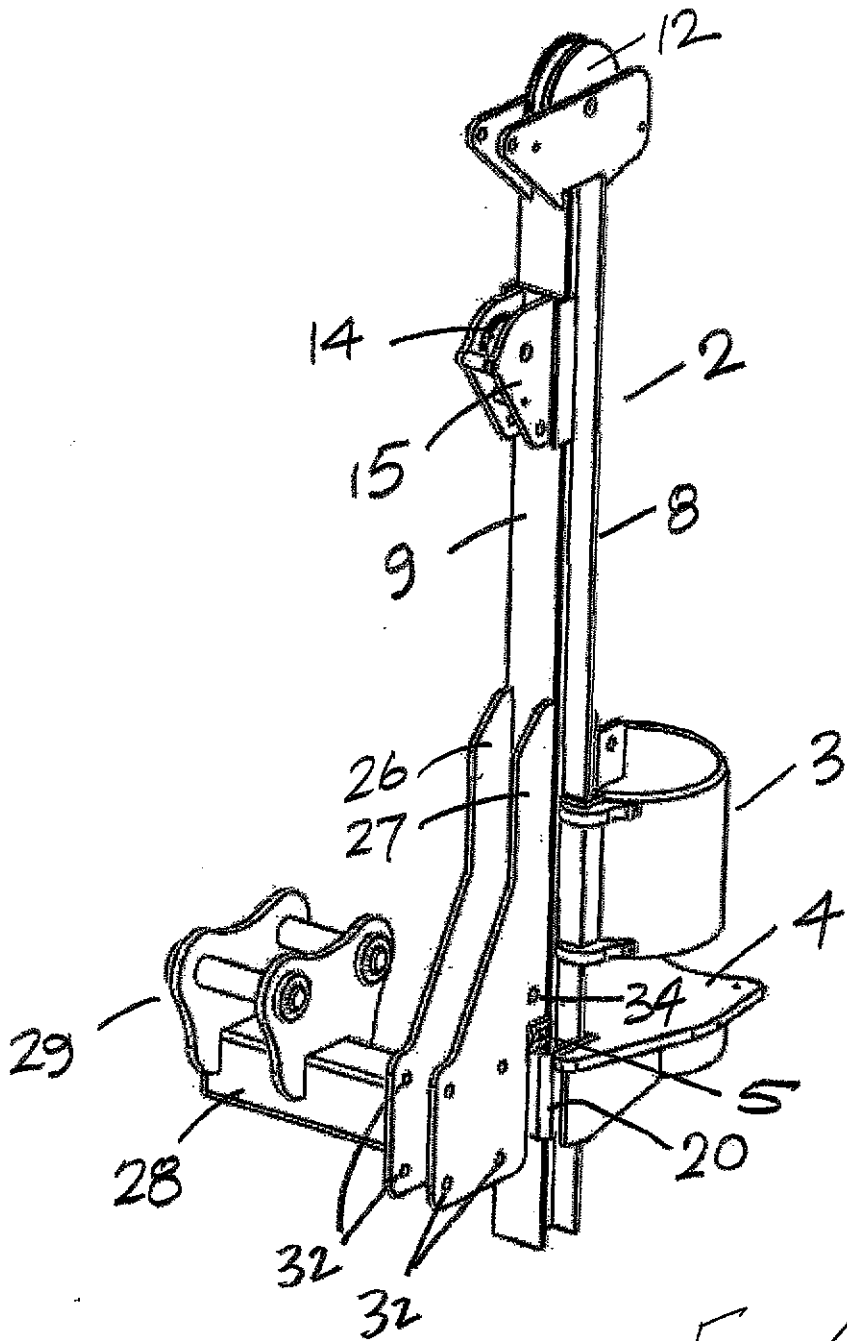

FIG 4

S85672

5/7

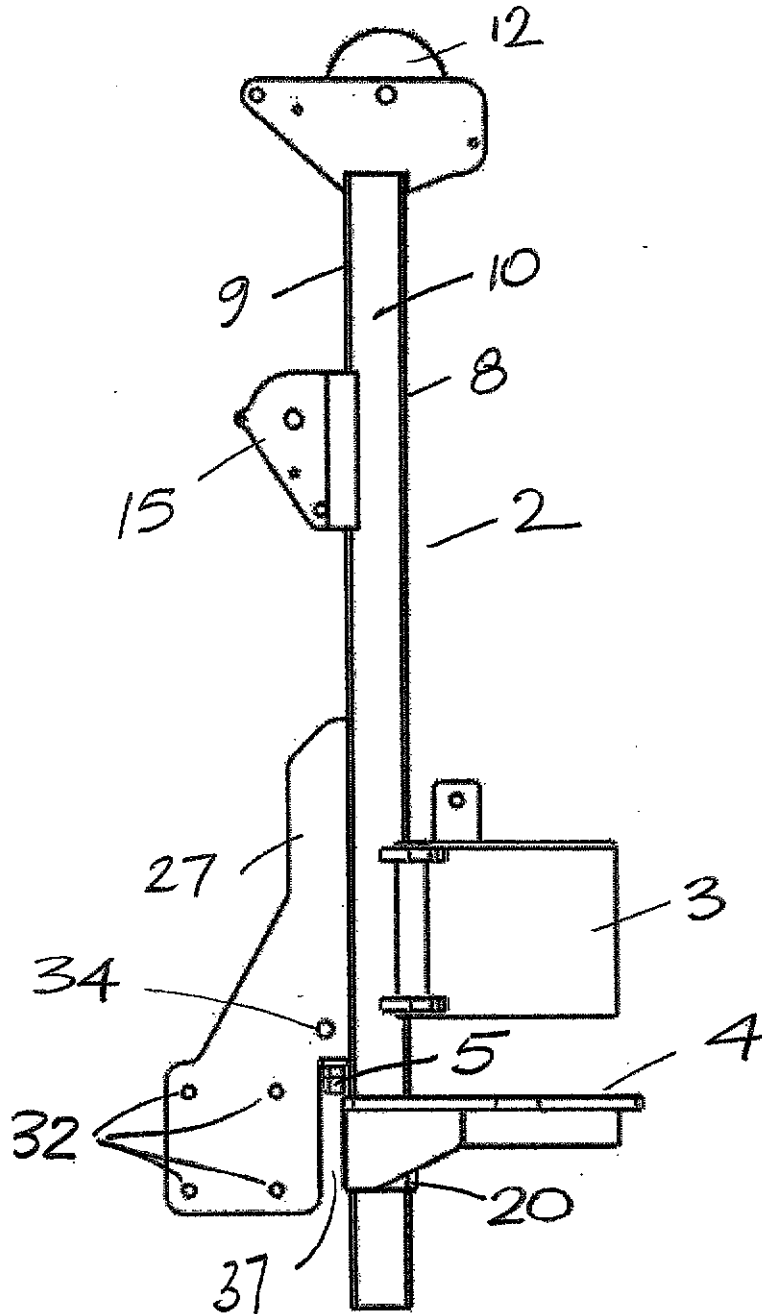

FIG 5

6/7

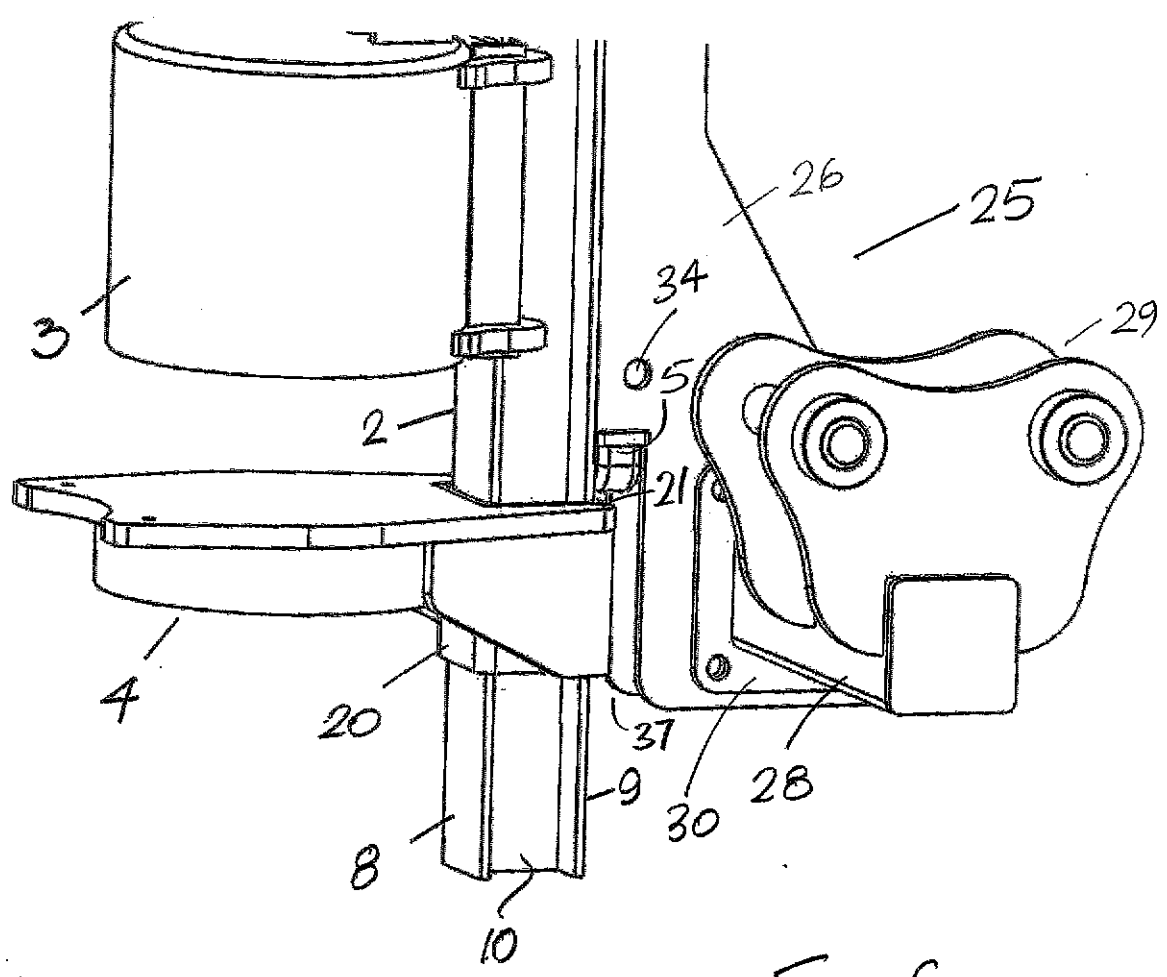

FIG 6

