

## FASCICULE DE BREVET D'INVENTION

21 Numéro de dépôt : 1201900383  
PCT/US2018/012633

22 Date de dépôt : 05/01/2018

30 Priorité(s) :

US n° 62/478,506 du 29/03/2017  
US n° 62/539,410 du 31/07/2017  
US n° 62/548,306 du 21/08/2017  
US n° 62/554,538 du 05/09/2017  
US n° 62/559,374 du 15/09/2017  
US n° 62/567,121 du 02/10/2017  
US n° 62/577,655 du 26/10/2017  
US n° 62/582,874 du 07/11/2017  
US n° 62/596,374 du 08/12/2017

24 Délivré le : 30/07/2020

45 Publié le : 23.10.2020

73 Titulaire(s) :

IOVANCE BIOTHERAPEUTICS, INC.,  
999 Skyway Road, Suite 150,  
SAN CARLOS, CA 94070 (US)

72 Inventeur(s) :

WARDELL, Seth (US)  
BENDER, James (US)  
LOTZE, Michael, T. (US)

74 Mandataire : S.C.P AKKUM, AKKUM & Associates,  
Quartier Mballa II, Dragages,  
B.P. 4966, YAOUNDE (CM).

54 Titre : Processes for production of tumor infiltrating lymphocytes and uses of same in immunotherapy.

57 Abrégé :

The present invention provides improved and/or shortened methods for expanding TILs and producing therapeutic populations of TILs, including novel methods for expanding TIL populations in a closed system that lead to improved efficacy, improved phenotype, and increased metabolic health of the TILs in a shorter time period, while allowing for reduced microbial contamination as well as decreased costs. Such TILs find use in therapeutic regimens.

Fig. 85

Figure 85

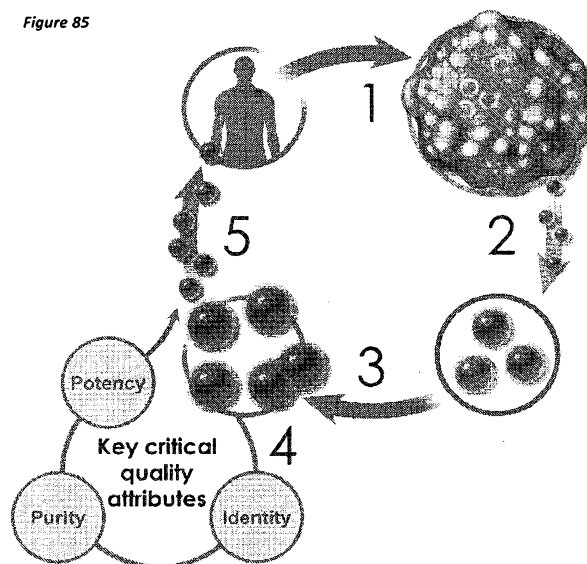

## PROCESSES FOR PRODUCTION OF TUMOR INFILTRATING LYMPHOCYTES AND USES OF SAME IN IMMUNOTHERAPY

### CROSS-REFERENCE TO RELATED APPLICATIONS

- 5 [0001] This application claims priority to U.S. Provisional Patent Application No. 62/478,506, filed on March 29, 2017, U.S. Provisional Patent Application No. 62/539,410, filed on July 31, 2017, U.S. Provisional Patent Application No. 62/548,306, filed on August 21, 2017, U.S. Provisional Patent Application No. 62/554,538, filed on September 5, 2017, U.S. Provisional Patent Application No. 62/559,374, filed on September 15, 2017, U.S. Provisional Patent Application No. 62/567,121, filed on October 2, 2017, U.S. Provisional Patent Application No. 62/577,655, filed on October 26, 2017, U.S. Provisional Patent Application No. 62/582,874, filed on November 7, 2017, and U.S. Provisional Patent Application No. 62/596,374, filed on December 8, 2017, which are hereby incorporated by reference in their entirety.

15

### SEQUENCE LISTING

[0002] The instant application contains a Sequence Listing which has been submitted electronically in ASCII format and is hereby incorporated by reference in its entirety. Said ASCII copy, created on January 4, 2018, is named 116983-5017\_ST25.txt and is 14 kilobytes in size.

20

### BACKGROUND OF THE INVENTION

- [0003] Treatment of bulky, refractory cancers using adoptive transfer of tumor infiltrating lymphocytes (TILs) represents a powerful approach to therapy for patients with poor prognoses. Gattinoni, *et al.*, *Nat. Rev. Immunol.* **2006**, *6*, 383-393. A large number of TILs are required for successful immunotherapy, and a robust and reliable process is needed for commercialization. This has been a challenge to achieve because of technical, logistical, and regulatory issues with cell expansion. IL-2-based TIL expansion followed by a “rapid expansion process” (REP) has become a preferred method for TIL expansion because of its speed and efficiency. Dudley, *et al.*, *Science* **2002**, *298*, 850-54; Dudley, *et al.*, *J. Clin. Oncol.* **2005**, *23*, 2346-57; Dudley, *et al.*, *J. Clin. Oncol.* **2008**, *26*, 5233-39; Riddell, *et al.*, *Science* **1992**, *257*, 238-41; Dudley, *et al.*, *J. Immunother.* **2003**, *26*, 332-42. REP can result in a 1,000-fold expansion of TILs over a 14-day period, although it requires a large excess

(*e.g.*, 200-fold) of irradiated allogeneic peripheral blood mononuclear cells (PBMCs, also known as mononuclear cells (MNCs)), often from multiple donors, as feeder cells, as well as anti-CD3 antibody (OKT3) and high doses of IL-2. Dudley, *et al.*, *J. Immunother.* **2003**, *26*, 332-42. TILs that have undergone an REP procedure have produced successful adoptive cell therapy following host immunosuppression in patients with melanoma. Current infusion acceptance parameters rely on readouts of the composition of TILs (*e.g.*, CD28, CD8, or CD4 positivity) and on fold expansion and viability of the REP product.

**[0004]** Current TIL manufacturing processes are limited by length, cost, sterility concerns, and other factors described herein such that the potential to commercialize such processes is severely limited, and for these and other reasons, at the present time no commercial process has become available. There is an urgent need to provide TIL manufacturing processes and therapies based on such processes that are appropriate for commercial scale manufacturing and regulatory approval for use in human patients at multiple clinical centers.

#### BRIEF SUMMARY OF THE INVENTION

**[0005]** The present invention provides improved and/or shortened methods for expanding TILs and producing therapeutic populations of TILs.

**[0006]** The present invention provides a method for expanding tumor infiltrating lymphocytes (TILs) into a therapeutic population of TILs comprising:

- (a) obtaining a first population of TILs from a tumor resected from a patient by processing a tumor sample obtained from the patient into multiple tumor fragments;
- (b) adding the tumor fragments into a closed system;
- (c) performing a first expansion by culturing the first population of TILs in a cell culture medium comprising IL-2 to produce a second population of TILs, wherein the first expansion is performed in a closed container providing a first gas-permeable surface area, wherein the first expansion is performed for about 3-14 days to obtain the second population of TILs, wherein the second population of TILs is at least 50-fold greater in number than the first population of TILs, and wherein the transition from step (b) to step (c) occurs without opening the system;
- (d) performing a second expansion by supplementing the cell culture medium of the second population of TILs with additional IL-2, OKT-3, and antigen presenting

cells (APCs), to produce a third population of TILs, wherein the second expansion is performed for about 7-14 days to obtain the third population of TILs, wherein the third population of TILs is a therapeutic population of TILs, wherein the second expansion is performed in a closed container providing a second gas-permeable surface area, and wherein the transition from step (c) to step (d) occurs without opening the system;

5

(e) harvesting the therapeutic population of TILs obtained from step (d), wherein the transition from step (d) to step (e) occurs without opening the system; and

(f) transferring the harvested TIL population from step (e) to an infusion bag,

10

wherein the transfer from step (e) to (f) occurs without opening the system.

**[0007]** In some embodiments, the method further comprises the step of cryopreserving the infusion bag comprising the harvested TIL population in step (f) using a cryopreservation process.

15

**[0008]** In some embodiments, the cryopreservation process is performed using a 1:1 ratio of harvested TIL population to cryopreservation media.

20

**[0009]** In some embodiments, the antigen-presenting cells are peripheral blood mononuclear cells (PBMCs). In some embodiments, the PBMCs are irradiated and allogeneic. In some embodiments, the PBMCs are added to the cell culture on any of days 9 through 14 in step (d). In some embodiments, the antigen-presenting cells are artificial antigen-presenting cells.

**[0010]** In some embodiments, the harvesting in step (e) is performed using a membrane-based cell processing system.

**[0011]** In some embodiments, the harvesting in step (e) is performed using a LOVO cell processing system.

25

**[0012]** In some embodiments, the multiple fragments comprise about 4 to about 50 fragments, wherein each fragment has a volume of about  $27 \text{ mm}^3$ .

**[0013]** In some embodiments, the multiple fragments comprise about 30 to about 60 fragments with a total volume of about  $1300 \text{ mm}^3$  to about  $1500 \text{ mm}^3$ .

30

**[0014]** In some embodiments, the multiple fragments comprise about 50 fragments with a total volume of about  $1350 \text{ mm}^3$ .

- [0015] In some embodiments, the multiple fragments comprise about 50 fragments with a total mass of about 1 gram to about 1.5 grams.
- [0016] In some embodiments, the cell culture medium is provided in a container selected from the group consisting of a G-container and a Xuri cellbag.
- 5 [0017] In some embodiments, the cell culture medium in step (d) further comprises IL-15 and/or IL-21.
- [0018] In some embodiments, the the IL-2 concentration is about 10,000 IU/mL to about 5,000 IU/mL.
- [0019] In some embodiments, the IL-15 concentration is about 500 IU/mL to about 100  
10 IU/mL.
- [0020] In some embodiments, the IL-21 concentration is about 20 IU/mL to about 0.5 IU/mL.
- [0021] In some embodiments, the infusion bag in step (f) is a HypoThermosol-containing infusion bag.
- 15 [0022] In some embodiments, the cryopreservation media comprises dimethylsulfoxide (DMSO). In some embodiments, the cryopreservation media comprises 7% to 10% dimethylsulfoxide (DMSO).
- [0023] In some embodiments, the first period in step (c) and the second period in step (e) are each individually performed within a period of 10 days, 11 days, or 12 days.
- 20 [0024] In some embodiments, the first period in step (c) and the second period in step (e) are each individually performed within a period of 11 days.
- [0025] In some embodiments, steps (a) through (f) are performed within a period of about 10 days to about 22 days.
- [0026] In some embodiments, steps (a) through (f) are performed within a period of about  
25 20 days to about 22 days.
- [0027] In some embodiments, steps (a) through (f) are performed within a period of about 15 days to about 20 days.
- [0028] In some embodiments, steps (a) through (f) are performed within a period of about 10 days to about 20 days.

- [0029] In some embodiments, steps (a) through (f) are performed within a period of about 10 days to about 15 days.
- [0030] In some embodiments, steps (a) through (f) are performed in 22 days or less.
- [0031] In some embodiments, steps (a) through (f) are performed in 20 days or less.
- 5 [0032] In some embodiments, steps (a) through (f) are performed in 15 days or less.
- [0033] In some embodiments, steps (a) through (f) are performed in 10 days or less.
- [0034] In some embodiments, steps (a) through (f) and cryopreservation are performed in 22 days or less.
- [0035] In some embodiments, the therapeutic population of TILs harvested in step (e)  
10 comprises sufficient TILs for a therapeutically effective dosage of the TILs.
- [0036] In some embodiments, the number of TILs sufficient for a therapeutically effective dosage is from about  $2.3 \times 10^{10}$  to about  $13.7 \times 10^{10}$ .
- [0037] In some embodiments, steps (b) through (e) are performed in a single container, wherein performing steps (b) through (e) in a single container results in an increase in TIL  
15 yield per resected tumor as compared to performing steps (b) through (e) in more than one container.
- [0038] In some embodiments, the antigen-presenting cells are added to the TILs during the second period in step (d) without opening the system.
- [0039] In some embodiments, the third population of TILs in step (d) provides for  
20 increased efficacy, increased interferon-gamma production, increased polyclonality, increased average IP-10, and/or increased average MCP-1 when administered to a subject.
- [0040] In some embodiments, the third population of TILs in step (d) provides for at least a five-fold or more interferon-gamma production when administered to a subject.
- [0041] In some embodiments, the third population of TILs in step (d) is a therapeutic  
25 population of TILs which comprises an increased subpopulation of effector T cells and/or central memory T cells relative to the second population of TILs, wherein the effector T cells and/or central memory T cells in the therapeutic population of TILs exhibit one or more characteristics selected from the group consisting of expressing CD27+, expressing CD28+,

longer telomeres, increased CD57 expression, and decreased CD56 expression relative to effector T cells, and/or central memory T cells obtained from the second population of cells.

[0042] In some embodiments, the effector T cells and/or central memory T cells obtained from the third population of TILs exhibit increased CD57 expression and decreased CD56

5 expression relative to effector T cells and/or central memory T cells obtained from the second population of cells.

[0043] In some embodiments, the risk of microbial contamination is reduced as compared to an open system.

[0044] In some embodiments, the TILs from step (g) are infused into a patient.

10 [0045] In some embodiments, the multiple fragments comprise about 4 fragments.

[0046] The present invention also provides a method for treating a subject with cancer, the method comprising administering expanded tumor infiltrating lymphocytes (TILs)

comprising:

- 15 (a) obtaining a first population of TILs from a tumor resected from a subject by processing a tumor sample obtained from the patient into multiple tumor fragments;
- (b) adding the tumor fragments into a closed system;
- (c) performing a first expansion by culturing the first population of TILs in a cell culture medium comprising IL-2 to produce a second population of TILs, wherein  
20 the first expansion is performed in a closed container providing a first gas-permeable surface area, wherein the first expansion is performed for about 3-14 days to obtain the second population of TILs, wherein the second population of TILs is at least 50-fold greater in number than the first population of TILs, and wherein the transition from step (b) to step (c) occurs without opening the system;
- 25 (d) performing a second expansion by supplementing the cell culture medium of the second population of TILs with additional IL-2, OKT-3, and antigen presenting cells (APCs), to produce a third population of TILs, wherein the second expansion is performed for about 7-14 days to obtain the third population of TILs, wherein  
30 the third population of TILs is a therapeutic population of TILs, wherein the second expansion is performed in a closed container providing a second gas-permeable surface area, and wherein the transition from step (c) to step (d) occurs

without opening the system;

(e) harvesting the therapeutic population of TILs obtained from step (d), wherein the transition from step (d) to step (e) occurs without opening the system; and

(f) transferring the harvested TIL population from step (e) to an infusion bag, wherein the transfer from step (e) to (f) occurs without opening the system;

(g) optionally cryopreserving the infusion bag comprising the harvested TIL population from step (f) using a cryopreservation process; and

(h) administering a therapeutically effective dosage of the third population of TILs from the infusion bag in step (g) to the patient.

10 [0047] In some embodiments, the therapeutic population of TILs harvested in step (e) comprises sufficient TILs for administering a therapeutically effective dosage of the TILs in step (h).

[0048] In some embodiments, the number of TILs sufficient for administering a therapeutically effective dosage in step (h) is from about  $2.3 \times 10^{10}$  to about  $13.7 \times 10^{10}$ .

15 [0049] In some embodiments, the antigen presenting cells (APCs) are PBMCs.

[0050] In some embodiments, the PBMCs are added to the cell culture on any of days 9 through 14 in step (d).

[0051] In some embodiments, prior to administering a therapeutically effective dosage of TIL cells in step (h), a non-myeloablative lymphodepletion regimen has been administered to the patient.

[0052] In some embodiments, the non-myeloablative lymphodepletion regimen comprises the steps of administration of cyclophosphamide at a dose of 60 mg/m<sup>2</sup>/day for two days followed by administration of fludarabine at a dose of 25 mg/m<sup>2</sup>/day for five days.

[0053] In some embodiments, the method further comprises the step of treating the patient with a high-dose IL-2 regimen starting on the day after administration of the TIL cells to the patient in step (h).

[0054] In some embodiments, the high-dose IL-2 regimen comprises 600,000 or 720,000 IU/kg administered as a 15-minute bolus intravenous infusion every eight hours until tolerance.

- [0055] In some embodiments, the third population of TILs in step (d) is a therapeutic population of TILs which comprises an increased subpopulation of effector T cells and/or central memory T cells relative to the second population of TILs, wherein the effector T cells and/or central memory T cells in the therapeutic population of TILs exhibit one or more characteristics selected from the group consisting of expressing CD27+, expressing CD28+, longer telomeres, increased CD57 expression, and decreased CD56 expression relative to effector T cells, and/or central memory T cells obtained from the second population of cells.
- [0056] In some embodiments, the effector T cells and/or central memory T cells in the therapeutic population of TILs exhibit increased CD57 expression and decreased CD56 expression relative to effector T cells and/or central memory T cells obtained from the second population of cells.
- [0057] In some embodiments, the cancer is selected from the group consisting of melanoma, ovarian cancer, cervical cancer, non-small-cell lung cancer (NSCLC), lung cancer, bladder cancer, breast cancer, cancer caused by human papilloma virus, head and neck cancer (including head and neck squamous cell carcinoma (HNSCC)), renal cancer, and renal cell carcinoma.
- [0058] In some embodiments, the cancer is selected from the group consisting of melanoma, HNSCC, cervical cancers, and NSCLC.
- [0059] In some embodiments, the cancer is melanoma.
- [0060] In some embodiments, the cancer is HNSCC.
- [0061] In some embodiments, the cancer is a cervical cancer.
- [0062] In some embodiments, the cancer is NSCLC.
- [0063] The present invention also provides methods for expanding tumor infiltrating lymphocytes (TILs) into a therapeutic population of TILs comprising:
- (a) adding processed tumor fragments from a tumor resected from a patient into a closed system to obtain a first population of TILs;
  - (b) performing a first expansion by culturing the first population of TILs in a cell culture medium comprising IL-2 to produce a second population of TILs, wherein the first expansion is performed in a closed container providing a first gas-permeable surface area, wherein the first expansion is performed for about 3-14

days to obtain the second population of TILs, wherein the second population of TILs is at least 50-fold greater in number than the first population of TILs, and wherein the transition from step (a) to step (b) occurs without opening the system;

5 (c) performing a second expansion by supplementing the cell culture medium of the second population of TILs with additional IL-2, OKT-3, and antigen presenting cells (APCs), to produce a third population of TILs, wherein the second expansion is performed for about 7-14 days to obtain the third population of TILs, wherein the third population of TILs is a therapeutic population of TILs, wherein the second expansion is performed in a closed container providing a second gas-  
10 permeable surface area, and wherein the transition from step (b) to step (c) occurs without opening the system;

(d) harvesting the therapeutic population of TILs obtained from step (c), wherein the transition from step (c) to step (d) occurs without opening the system; and

15 (e) transferring the harvested TIL population from step (d) to an infusion bag, wherein the transfer from step (d) to (e) occurs without opening the system.

**[0064]** In some embodiments, the therapeutic population of TILs harvested in step (d) comprises sufficient TILs for a therapeutically effective dosage of the TILs.

**[0065]** In some embodiments, the number of TILs sufficient for a therapeutically effective dosage is from about  $2.3 \times 10^{10}$  to about  $13.7 \times 10^{10}$ .

20 **[0066]** In some embodiments, the method further comprises the step of cryopreserving the infusion bag comprising the harvested TIL population using a cryopreservation process.

**[0067]** In some embodiments, the cryopreservation process is performed using a 1:1 ratio of harvested TIL population to cryopreservation media.

25 **[0068]** In some embodiments, the antigen-presenting cells are peripheral blood mononuclear cells (PBMCs).

**[0069]** In some embodiments, the PBMCs are irradiated and allogeneic.

**[0070]** The method according to claim 68, wherein the PBMCs are added to the cell culture on any of days 9 through 14 in step (c).

30 **[0071]** In some embodiments, the antigen-presenting cells are artificial antigen-presenting cells.

- [0072] In some embodiments, the harvesting in step (d) is performed using a LOVO cell processing system.
- [0073] In some embodiments, the multiple fragments comprise about 4 to about 50 fragments, wherein each fragment has a volume of about 27 mm<sup>3</sup>.
- 5 [0074] In some embodiments, the multiple fragments comprise about 30 to about 60 fragments with a total volume of about 1300 mm<sup>3</sup> to about 1500 mm<sup>3</sup>.
- [0075] In some embodiments, the multiple fragments comprise about 50 fragments with a total volume of about 1350 mm<sup>3</sup>.
- [0076] In some embodiments, the multiple fragments comprise about 50 fragments with a  
10 total mass of about 1 gram to about 1.5 grams.
- [0077] In some embodiments, the multiple fragments comprise about 4 fragments.
- [0078] In some embodiments, the second cell culture medium is provided in a container selected from the group consisting of a G-container and a Xuri cellbag.
- [0079] In some embodiments, the infusion bag in step (e) is a HypoThermosol-containing  
15 infusion bag.
- [0080] In some embodiments, the first period in step (b) and the second period in step (c) are each individually performed within a period of 10 days, 11 days, or 12 days.
- [0081] In some embodiments, the first period in step (b) and the second period in step (c) are each individually performed within a period of 11 days.
- 20 [0082] In some embodiments, steps (a) through (e) are performed within a period of about 10 days to about 22 days.
- [0083] In some embodiments, steps (a) through (e) are performed within a period of about 10 days to about 20 days.
- [0084] In some embodiments, steps (a) through (e) are performed within a period of about  
25 10 days to about 15 days.
- [0085] In some embodiments, steps (a) through (e) are performed in 22 days or less.
- [0086] In some embodiments, steps (a) through (e) and cryopreservation are performed in 22 days or less.

- [0087] In some embodiments, steps (b) through (e) are performed in a single container, wherein performing steps (b) through (e) in a single container results in an increase in TIL yield per resected tumor as compared to performing steps (b) through (e) in more than one container.
- 5 [0088] In some embodiments, the antigen-presenting cells are added to the TILs during the second period in step (c) without opening the system.
- [0089] In some embodiments, the third population of TILs in step (d) is a therapeutic population of TILs which comprises an increased subpopulation of effector T cells and/or central memory T cells relative to the second population of TILs, wherein the effector T cells  
10 and/or central memory T cells obtained in the therapeutic population of TILs exhibit one or more characteristics selected from the group consisting of expressing CD27+, expressing CD28+, longer telomeres, increased CD57 expression, and decreased CD56 expression relative to effector T cells, and/or central memory T cells obtained from the second population of cells.
- 15 [0090] In some embodiments, the effector T cells and/or central memory T cells obtained in the therapeutic population of TILs exhibit increased CD57 expression and decreased CD56 expression relative to effector T cells, and/or central memory T cells obtained from the second population of cells.
- [0091] In some embodiments, the risk of microbial contamination is reduced as compared  
20 to an open system.
- [0092] In some embodiments, the TILs from step (e) are infused into a patient.
- [0093] In some embodiments, the closed container comprises a single bioreactor.
- [0094] In some embodiments, the closed container comprises a G-REX-10.
- [0095] In some embodiments, the closed container comprises a G-REX -100.
- 25 [0096] In some embodiments, at step (d) the antigen presenting cells (APCs) are added to the cell culture of the second population of TILs at a APC:TIL ratio of 25:1 to 100:1.
- [0097] In some embodiments, the cell culture has a ratio of  $2.5 \times 10^9$  APCs to  $100 \times 10^6$  TILs.
- [0098] In some embodiments, at step (c) the antigen presenting cells (APCs) are added to the cell culture of the second population of TILs at a APC:TIL ratio of 25:1 to 100:1.

[0099] In some embodiments, the cell culture has ratio of  $2.5 \times 10^9$  APCs to  $100 \times 10^6$  TILs.

[00100] The present invention also provides a population of expanded TILs for use in the treatment of a subject with cancer, wherein the population of expanded TILs is a third population of TILs obtainable by a method comprising:

- 5 (a) obtaining a first population of TILs from a tumor resected from a subject by processing a tumor sample obtained from the patient into multiple tumor fragments;
- (b) adding the tumor fragments into a closed system;
- (c) performing a first expansion by culturing the first population of TILs in a cell  
10 culture medium comprising IL-2 to produce a second population of TILs, wherein the first expansion is performed in a closed container providing a first gas-permeable surface area, wherein the first expansion is performed for about 3-14 days to obtain the second population of TILs, wherein the second population of TILs is at least 50-fold greater in number than the first population of TILs, and  
15 wherein the transition from step (b) to step (c) occurs without opening the system;
- (d) performing a second expansion by supplementing the cell culture medium of the second population of TILs with additional IL-2, OKT-3, and antigen presenting cells (APCs), to produce a third population of TILs, wherein the second expansion  
20 is performed for about 7-14 days to obtain the third population of TILs, wherein the third population of TILs is a therapeutic population of TILs, wherein the second expansion is performed in a closed container providing a second gas-permeable surface area, and wherein the transition from step (c) to step (d) occurs without opening the system;
- (e) harvesting the therapeutic population of TILs obtained from step (d), wherein the  
25 transition from step (d) to step (e) occurs without opening the system; and
- (f) transferring the harvested TIL population from step (e) to an infusion bag, wherein the transfer from step (e) to (f) occurs without opening the system; and
- (g) optionally cryopreserving the infusion bag comprising the harvested TIL population from step (f) using a cryopreservation process.

30 [00101] In some embodiments, the population of TILs is for use to treat a subject with cancer according to the methods described above and herein, wherein the method further comprises one or more of the features recited above and herein.

**BRIEF DESCRIPTION OF THE DRAWINGS**

- [00102] **Figure 1:** Shows a diagram of an embodiment of process 2A, a 22-day process for TIL manufacturing.
- 5 [00103] **Figure 2:** Shows a comparison between the 1C process and an embodiment of the 2A process for TIL manufacturing.
- [00104] **Figure 3:** Shows the 1C process timeline.
- [00105] **Figure 4:** Shows the process of an embodiment of TIL therapy using process 2A for TIL manufacturing, including administration and co-therapy steps, for higher cell counts.
- 10 [00106] **Figure 5:** Shows the process of an embodiment of TIL therapy using process 2A for TIL manufacturing, including administration and co-therapy steps, for lower cell counts.
- [00107] **Figure 6:** Shows a detailed schematic for an embodiment of the 2A process.
- [00108] **Figure 7:** Shows characterization of TILs prepared using an embodiment of the 2A process by comparing interferon-gamma (IFN- $\gamma$ ) expression between fresh TILs and thawed  
15 TILs.
- [00109] **Figure 8:** Shows characterization of TILs prepared using an embodiment of the 2A process by examining CD3 expression in fresh TILs versus thawed TILs.
- [00110] **Figure 9:** Shows characterization of TILs prepared using an embodiment of the 2A process by examining recovery in fresh TILs versus thawed TILs.
- 20 [00111] **Figure 10:** Shows characterization of TILs prepared using an embodiment of the 2A process by examining viability of fresh TILs versus thawed TILs.
- [00112] **Figure 11:** Depicts the major steps of an embodiment of process 2A including the cryopreservation steps.
- [00113] **Figure 12:** Depicts cell counts obtained from the 1C process and an embodiment of  
25 the 2A process.
- [00114] **Figure 13:** Depicts percent cell viability obtained from the 1C process and an embodiment of the 2A process.

- [00115] **Figure 14:** Depicts percentages of CD45 and CD3 cells (i.e., T cells) measured by flow cytometry for TILs obtained for the 1C process and an embodiment of the 2A process.
- [00116] **Figure 15:** Depicts IFN- $\gamma$  release obtained for the 1C process and embodiments of the 2A process, as measured by an assay different than that used to generate the data in  
5 Figures 80 and 98.
- [00117] **Figure 16:** Depicts IFN- $\gamma$  release obtained for the 1C process and embodiments of the 2A process, as measured by an assay different than that used to generate the data in  
Figures 80 and 98.
- [00118] **Figure 17:** Depicts percentages of TCR a/b and NK cells obtained from the 1C  
10 process and an embodiment of the 2A process.
- [00119] **Figure 18:** Depicts percentages of CD8<sup>+</sup> and CD4<sup>+</sup> cells measured by flow cytometry for TILs obtained by the 1C process and an embodiment of the 2A process, as well as the ratio between each subset.
- [00120] **Figure 19:** Depicts percentages of memory subsets measured by flow cytometry for  
15 TILs obtained from the 1C process and an embodiment of the 2A process.
- [00121] **Figure 20:** Depicts percentages of PD-1, LAG-3, and TIM-3 expression by flow cytometry for TILs obtained from the 1C process and an embodiment of the 2A process.
- [00122] **Figure 21:** Depicts percentages of 4-1BB, CD69, and KLRG1 expression by flow cytometry for TILs obtained from the 1C process and an embodiment of the 2A process.
- [00123] **Figure 22:** Depicts percentages of TIGIT expression by flow cytometry for TILs  
20 obtained from the 1C process and an embodiment of the 2A process.
- [00124] **Figure 23:** Depicts percentages of CD27 and CD28 expression by flow cytometry for TILs obtained from the 1C process and an embodiment of the 2A process.
- [00125] **Figure 24:** Depicts the results of flow-FISH telomere length analysis.
- [00126] **Figure 25:** Depicts the results of flow-FISH telomere length analysis (after removal  
25 of an outlier data point).
- [00127] **Figure 26:** Depicts the clinical trial design including cohorts treated with process 1C and an embodiment of process 2A.

- [00128] **Figure 27:** Exemplary Process 2A chart providing an overview of Steps A through F.
- [00129] **Figure 28:** Process Flow Chart of Process 2A.
- [00130] **Figure 29:** Process Flow Chart on Process 2A Data Collection Plan
- 5 [00131] **Figure 30:** Viability of fresh vs. thawed TIL
- [00132] **Figure 31:** Expansion of fresh and thawed TIL in re-REP culture
- [00133] **Figure 32:** Normal laboratory values of blood metabolites.
- [00134] **Figure 33:** Metabolite analysis of process 2A pre-REP TIL.
- [00135] **Figure 34:** Quantification of IL-2 in process 2A pre-REP TIL cell culture.
- 10 [00136] **Figure 35:** Release of cytotoxic cytokines IFN- $\gamma$  upon anti-CD3, anti-CD28 and anti-4-1BB stimulation of TIL.
- [00137] **Figure 36:** Release of Granzyme B following anti-CD3, anti-CD28, and anti-4-1BB stimulation of TIL.
- [00138] **Figure 37:** TCR  $\alpha\beta$ + TIL. Most human CD3+ T-cells express the receptors formed  
15 by  $\alpha$  and  $\beta$  chains that recognize antigens in an MHC restricted manner. A) Except in M1061, fresh and thawed TIL product had 80% or more TCR  $\alpha\beta$ + expressing TIL. Both fresh and thaw TIL had comparable expression of TCR  $\alpha\beta$  (p-value = 0.9582). Even though a decrease in the TCR  $\alpha\beta$ + expressing TIL after the Re-REP was observed, this decrease was not significant within the Re-REP TIL (p = 0.24). B) There was a 9.2% and 15.7% decrease in  
20 the fresh and thaw RE-REP TIL expressing TCR  $\alpha\beta$  in comparison to fresh and thaw TIL respectively.
- [00139] **Figure 38:** TCR $\alpha\beta$ -CD56+. Tumor infiltrating Natural Killer (NK) and NKT-cells also have the ability to lyse cells lacking MHC expression as well as CD1-presented lipid antigen and to provide immunoregulatory cytokines. However, an intense NK cell infiltration  
25 is associated with advanced disease and could facilitate cancer development. Figure A shows that in all instances, except in M1063, there was a modest, though not significant, decrease in NK population in thawed TIL compared to fresh TIL, (p = 0.27). No significant difference was observed between the re-REP TIL population (p = 0.88). Fresh TIL, fresh re-REP TIL, and thawed re-REP TIL demonstrate similar expression of CD56 as shown in Figure B.

Thawed TIL product had less ( $1.9 \pm 1.3$ ) NK-expressing cells than fresh TIL ( $3.0 \pm 2.2$ ) possibly as a result of the cryo-freezing procedure.

**[00140] Figure 39:** CD4+ cells. No substantial difference in the CD4 population was observed in individual conditions. Figure A represents the average CD4 population in each condition. The table in Figure B shows the SD and SEM values. There is a slight decrease in the CD4 population in the fresh re-REP population which is mostly due to a decrease in CD4 in the fresh re-REP population in EP11001T.

**[00141] Figure 40:** CD8+ cells. A) In all, except EP11001T, both fresh and thawed TIL showed comparable CD8+ populations ( $p=0.10$ , no significant difference). In most experiments, there was a slight decrease in the CD8+ expressing TIL in the fresh re-REP TIL product (exceptions were M1061T and M1065T). There was approximately a 10-30% decrease in the CD8+ population in the thawed re-REP TIL. Comparison of the re-REP TIL from both fresh and thawed TIL showed a significant difference ( $p = 0.03$ , Student's t-test). Figure B shows the mean values of the CD8+ expressing TIL in all conditions. Both fresh and thawed TIL show similar results. However, there was a 10.8% decrease in the CD8+ population in the thawed re-REP TIL product in comparison to the fresh re-REP TIL.

**[00142] Figure 41:** CD4+CD154+ cells. CD154, also known as CD40L is a marker for activated T-cells. Figure A: No substantial difference in the CD4+CD154+ population was observed in the different conditions, however, a decrease of 34.1% was observed in the EP11001T fresh re-REP CD4+ TILs. CD154 expression were not measured in M1061T and M1062T as these experiments were carried out before the extended phenotype panel was in place. Figure B: A slight decrease in thawed TIL condition could be attributed to CD154 not measured in M1061T and M1062T. All conditions show very comparable CD154 expression in the CD4 population suggesting activated CD4+ T cells.

**[00143] Figure 42A-42B:** CD8+CD154+ cells. Activation marker CD154 expressed on CD8+ TIL was also analyzed. A) Overall, the CD154 expression was lower in the CD8+ population in the fresh and thawed TIL product. This is not surprising as CD154 is expressed mainly in the activated CD4+ T cells. In cases where the CD154 expression was measured in both fresh and thawed TIL product, either a no difference or an increase in the CD154 expression was observed in the thawed TIL products. Student's t-test showed there was no significant difference between the two conditions. An increase in the CD154 expression in the thawed re-REP in comparison to the fresh re-REP was shown in all experiments ( $p =$

0.02). B) An increase in CD154 expression was observed in both the thawed TIL and thawed re-REP TIL products in comparison to their counterparts. Thawed re-REP TIL showed a 29.1% increase in CD154 expression compared to the fresh re-REP TIL.

5 [00144] **Figure 43A-43B:** CD4+CD69+ cells. CD69 is the early activation marker in T cell following stimulation or activation. A) In all TIL except in EP11001T, both fresh and thawed re-REP showed a modest increase in CD69 expression, possibly due to the re-REP length (7 days rather than 11 days). No difference was observed between fresh and thawed TIL ( $p = 0.89$ ). A difference between fresh and thawed re-REP was also not observed ( $p = 0.82$ ). B) A minor increase in CD69 expression is observed in the re-REP TIL products. (Note: No CD69  
10 staining was performed for either M1061T and M1062T thawed TIL product. CD69 expression of M1061T fresh TIL product was 33.9%).

[00145] **Figure 44A-44B:** CD8+CD69+ cells. As observed for the CD4+ population, Figure A shows an increase in the CD69 expression in the CD8+ re-REP TIL. CD69 expression showed no significant difference between the fresh and thawed TIL ( $p = 0.68$ ) or the fresh  
15 and thawed re-REP TIL ( $p = 0.76$ ). Figure B supports the observation that there is a modest increase in the CD69 expression in the re-REP TIL product.

[00146] **Figure 45A-45B:** CD4+CD137+ cells. CD137 (4-11313) is a T-cell costimulatory receptor induced upon TCR activation. It is activated on CD4+ and CD8+ T cells. A) CD137 expression showed a profound increase in the re-REP TIL population following 7 days of  
20 stimulation. However, no difference between the fresh and thawed TIL or fresh and thawed re-REP TIL were observed ( $p < 0.05$  in both cases Figure B supports this observation). Also, the thawed TIL showed a modest decrease in CD137 expression. The increase in CD137 expression in re-REP TIL could be attributed to the second round of stimulation of the 7-day re-REP.

25 [00147] **Figure 46A-46B:** CD8+CD137+ cells. A) CD8+ population showed an overall increase in the re-REP product. B) Fresh re-REP product had a 33.4% increase in CD8+CD137+ expression in comparison to fresh TIL product. Thawed re-REP product also showed a 33.15% increase in CD137 expression in the CD8+ population compared to thawed TIL. No significant differences were observed between fresh and thawed re-REP TIL. A  
30 similar observation can be seen comparing the fresh TIL to the thawed TIL product. This increase in CD137 expression could be due to the second round of activation of the re-REP.

(Note that only 6 TIL were used for the analysis as CD137 expression were not measured for 3 of the experiments.)

**[00148] Figure 47A-47B: CD4+CM cells.** Central Memory (CM) population is defined by CD45RA- (negative) and CCR7+ (positive) expression. A) An increase in the CM population  
5 in the re-REP conditions were observed. M1063T and M1064T showed a decrease in the CM expression in the CD4+ population obtained from thawed TIL in comparison to fresh TIL product. Neither fresh and thawed TIL product ( $p = 0.1658$ ) nor fresh re-REP and thaw re-REP TIL ( $p = 0.5535$ ) showed a significant difference in CM population. B) A 14.4% and 15.4% increase in the CM population was observed in the fresh and thawed re-REP TIL in  
10 comparison to fresh and thawed TIL respectively.

**[00149] Figure 48A-48B: CD8+CM cells.** A) In the CD8+ population, a dramatic increase in CM expression in the fresh TIL product was seen, an observation not present in the TIL product. This increase did not affect the significance ( $p = 0.3086$ ), suggesting no difference between the fresh and thawed TIL. A similar trend was seen in the re-REP TIL products as  
15 well. Figure 48B) An overall increase in CM population in the fresh TIL was observed in comparison to the thawed TIL. The numbers show that fresh TIL and re-REP TIL had only a difference of ~2%; the fresh TIL showed a very high standard deviation which could be attributed to M1064T; excluding the CM expression in M1064T resulted in very similar CM expression between the fresh and thawed TIL product (not shown).

**[00150] Figure 49A-49B: CD4+EM cells.** Effector memory (EM) population is defined by the lack of CCR7 and CD45RA expression. A) As expected the CD4+ population from fresh and thawed TIL had a high level of effector memory phenotype. A drastic decrease in the effector memory expression was found in the M1056T re-REP TIL population. Also, 5 other  
25 experiments showed a decrease in the effector memory phenotype in both fresh and thawed re-REP TIL. B) Both fresh and thawed TIL showed similar expression of effector memory phenotype. Comparison of fresh and fresh Re-REP TIL showed a decrease by 16% in the latter. A similar decrease was observed in the thawed Re-REP TIL (9%) when compared to the thawed TIL.

**[00151] Figure 50A-50B: CD8+EM cells.** A) A similar pattern of increased effector  
30 memory in the fresh TIL was also seen in the CD8+ population. An exception was noted in the M1064T in which fresh TIL only had a 20% effector memory profile; this is due to the 73% of these TIL having a CM phenotype as described in A and B. All the samples showing

a decrease in the effector memory population in their CD4+ TIL from the re-REP product followed the same trend in their CD8+TIL. B) Unlike the CD4+ TIL population, CD8+ TIL showed a similar effector memory phenotype in fresh, thawed and re-REP products. (Note the high standard deviation in the fresh and thawed TIL, which are due to the low effector memory population in M1064T fresh and to no expression in M1061T thawed TIL samples.)

5 [00152] **Figure 51A-51B: CD4+CD28+ cells.** CD28 expression correlates with young TIL decreasing with age. A) Even though an increase in the CM population was observed in the re-REP TIL, a decrease in the CD28 expression was seen as a trend suggesting that CM-status alone could not determine the fate of TIL. A decrease in CD28 expression was  
10 observed in the -re-REP product, except for M1061T CD4+ TIL. B) A decrease of 8.89% in the fresh and 5.71% in the thawed TIL was seen compared to fresh and thawed TIL product, respectively.

[00153] **Figure 52A-52B: CD8+CD28+ cells.** A) CD28 expression in the CD8+ TIL population was higher in the fresh and thawed TIL than re-REP product. In most cases,  
15 thawed re-REP TIL showed a drastic decrease when compared to thawed TIL and fresh re-REP TIL. However, Student's t-test showed no significant difference between fresh and thawed TIL ( $p = 0.3668$ ) and also between the fresh and thawed re-REP products ( $p = 0.7940$ ). B) As seen in the CD4+ TIL population, there was a decrease in CD8+CD28+ populations in the fresh re-REP (21.5%) and thawed re-REP (18.2%) when compared to their  
20 non-restimulated counterparts.

[00154] **Figure 53A-53B: CD4+PD-1+ cells.** PD-1 expression in TIL is correlated with antigen reactive and exhausted T cells. I Thus it is not surprising that an exhausted phenotype is observed in TIL which have undergone a REP for 11 days. A) This exhausted phenotype was either maintained or increased (specifically, EP11001T and M1056T) in the thawed TIL  
25 product. No significant difference between fresh and thawed TIL product was seen ( $p = 0.9809$ ). A similar trend was shown in the fresh compared to thawed re-REP TIL ( $p = 0.0912$ ). B) Fresh re-REP showed a modest decrease in PD-1 expression in the CD4+ TIL population. All the other conditions maintained a comparable PD-1 expression pattern. A decrease or no change in PD-1 expression was observed in fresh re-REP product compared to  
30 all other conditions. An increase in the PD-1 expression was seen in M1062T, M1063T (CD4+) and EP11001T (CD8+) in the thawed re-REP product. All other thawed re-REP product showed comparable results to the thawed product.

[00155] **Figure 54A-54B:** CD8+PD-1+ cells. A) CD8+ population from the fresh TIL product showed a more exhausted phenotype associated with increased PD-1 expression. An exception was observed in EP11001T where CD8+ thawed TIL product had a modest increase in the PD-1 expression compared to fresh TIL product. There was a small, though  
5 non-significant difference in the PD-1 expression in the fresh TIL compared to thawed TIL ( $p = 0.3144$ ). B) Fresh TIL product showed a slight increase, but non-significant PD-1 expression compared to thawed TIL (6.74%, or 1.2-fold higher than thawed TIL) suggesting that the thawed TIL product was comparable based on the phenotype pattern.

[00156] **Figure 55A-55B:** CD4+LAG3+ cells. Exhausted T cells express high levels of  
10 inhibitory receptor LAG3 along with PD-1. A) The CD4+ thawed TIL showed slightly higher, but non-significant, levels of LAG3 expression in comparison to the fresh TIL ( $p = 0.52$ ). An exception was observed in M1063T. In experiments where LAG3 expression in the CD4+ fresh and fresh re-REP TIL were measured, a decrease in LAG3+ expression was observed in the fresh re-REP samples compared to fresh TIL. B) Overall, there is a modest  
15 decrease in the LAG3 expression in fresh re-REP TIL product. Please note that for Figure B to maintain consistent, M1061T, M1062T and M1064T were excluded as LAG3 expression were not measured in the fresh product.

[00157] **Figure 56A-56B:** CD8+LAG3+ cells. A) CD8+ LAG3+ expressing TIL showed a  
20 modest decrease in the experiments, with the exception of M1063T in which a marked decrease in LAG3 expression was seen in the fresh re-REP TIL. Overall, thawed re-REP TIL showed a 1.5-fold, significant increase compared to fresh re-REP TIL for LAG3 expression ( $p = 0.0154$ ). However, no significant difference was observed between fresh TIL and thawed TIL products ( $p = 0.0884$ ). B) An approximate 30% decrease in LAG3 expression in the CD8+ TIL from fresh re-REP was observed in comparison to thawed TIL product. Both  
25 fresh and thawed TIL were comparable to thawed TIL showing a modest increase. (In this figure, M1061T, M1062T and M1064T were omitted as LAG3 expression was not measured in the either the fresh or fresh re-REP TIL samples.)

[00158] **Figure 57A-57B:** CD4+TIM-3+ cells. A) As observed previously in the case of PD-  
30 l and LAG3, a decrease in TIM-3 expression was seen in the fresh reREP TIL compared to thawed re-REP TIL. Regardless, no significant difference existed between fresh and thawed reREP TIL ( $p = 0.2007$ ). B) No major changes in TIM-3 expression was observed among

fresh, thaw and thawed reREP TIL products. A modest decrease of 9.2% in TIM-3 expression was observed in the fresh reREP TIL in comparison to thawed reREP product.

5 **[00159] Figure 58A-58B:** CD8+TIM-3+ cells. A) A similar trend in TIM-3 expression that was seen in the CD4+ population was also seen in the CD8+ TIL. Fresh re-REP TIL had the least exhausted phenotype with low TIM-3 expression, showing a significant difference in comparison to thawed re-REP TIL ( $p = 0.0147$ ). Comparison of PD-1, LAG3 and TIM-3 suggests that fresh re-REP TIL had a less exhaustive phenotype with increased CM phenotype. B) In comparison to thawed re-REP TIL product, fresh re-REP TIL showed a significant 22% decrease in TIM-3 expression. Both fresh and thawed TIL show similar TIM-3 expression patterns.

**[00160] Figure 59:** Cytotoxic potential of TIL against P815 target cell line.

**[00161] Figure 60A-60F:** Metabolic respiration profile of fresh TIL, fresh re-REP TIL, and thawed re-REP TIL. Basal OCR (A), Overt SRC (B), SRC2DG (C), Covert SRC (D), Basal ECAR (E), and Glycolytic Reserve (F).

15 **[00162] Figure 61A-61B:** Flow-FISH technology was used to measure average length of Telomere repeat in 9 post-REP Process 2A thawed TIL products. A) Data represents the telomere length measured by qPCR comparing TIL to 1301 cells B) Data shows the telomere length measured by Flow Fish Assay of TIL compared to 1301 cells. Data used for graphs are provided in a table format (Tables 25) in the appendix section 10. Overall, there was a rough  
20 similarity in the patterns of the results of the two telomere length assays, but experiments will continue to determine which method more accurately reflects the actual telomere length of the TIL. This technique could be applied to future clinical samples to determine a relationship between telomere length and patient response to TIL therapy.

**[00163] Figure 62A-62B:** Selection of Serum Free Media purveyor (Serum replacement).  
25 Each fragment were cultured in single well of G-Rex 24 well plate in quatraplicates. On Day 11, REP were initiated using  $4^5$  TIL with  $10^6$  Feeders to mimic 2A process. A) Bar graph showing average viable cell count recorded on Day 11 (preREP) for each conditions. B) Bar graph displaying average viable cell count recorded on Day 22 (postREP). P value were calculated using student 't'test. \*  $P < 0.05$ , \*\*  $P < 0.01$ , \*\*\*  $P < 0.001$  respectively.

30 **[00164] Figure 63A-63B:** Selection of Serum Free Media purveyor (Platelet Lysate serum). Each fragment were cultured in single well of G-Rex 24 well plate in triplicates. On Day 11,

REP were initiated using  $4 \times 10^5$  TIL with  $10 \times 10^6$  Feeders to mimic 2A process. A) Bar graph showing average viable cell count recorded on Day 11 (preREP) for each conditions. B) Bar graph displaying average viable cell count recorded on Day 22 (postREP). P value were calculated using student 't'test. \* P < 0.05, \*\* P < 0.01, \*\*\* P < 0.001 respectively. '#'Not enough tumor fragments.

[00165] **Figure 64A-64B:** Compare the efficacy of CTS Optimizer with standard condition using mini scale 2A process (G-Rex 5M). Two fragments / G-Rex 5M were cultured in triplicates, REP were initiated using  $2 \times 10^6$  TIL with  $50 \times 10^6$  Feeders to mimic 2A process. Bar presented above were average viable cell count obtained on Day 11 (A) or Day 22 (B).

10 [00166] **Figure 65A-65C:** Summary of pre and post TIL expansion extrapolated comparing standard condition and CTS Optimizer. A) PreREP. B) PostREP. C) Summary of TIL expansion extrapolated to full scale run (Standard vs CTS Optimizer +SR).

[00167] **Figure 66:** CD8+ was gated on live cells. 7 of the 9 tumors show an increase in absolute CD8+ populations with the CTS+SR condition.

15 [00168] **Figure 67:** Interferon-gamma Comparability. Interferon-gamma ELISA (Quantikine). Production of IFN- $\gamma$  was measured using Quantikine ELISA kit by R&D systems. CTS+SR produced comparable amounts of IFN- $\gamma$  when compared to our standard condition.

[00169] **Figure 68:** Scheme of an exemplary embodiment of the Rapid Expansion Protocol (REP). Upon arrival the tumor is fragmented, placed into G-Rex flasks with IL-2 for TIL expansion (pre-REP expansion), for 11 days. For the triple cocktail studies, IL-2/IL-15/IL-21 is added at the initiation of the pre-REP. For the Rapid Expansion Protocol (REP), TIL are cultured with feeders and OKT3 for REP expansion for an additional 11 days.

25 [00170] **Figure 69:** TIL derived from melanoma (n=4), and lung (n=7) were assessed phenotypically for CD4+ and CD8+ cells using flow cytometry post pre-REP. \*P-values represent the difference between the IL-2 and IL-12/IL-15/IL-21 in the CD8+ cells using student's unpaired t test.

[00171] **Figure 70:** TIL derived from melanoma (n=4), and lung (n=7) were assessed phenotypically for CD27+ and CD28+ in the CD4+ and CD8+ cells using flow cytometry post pre-REP.

30

- [00172] Figure 71A-71B:** TIL were assessed phenotypically for effector/memory subsets (CD45RA and CCR7) in the CD8+ cells and CD4+ (data not shown) in melanoma (n=4) (A) and lung (n=8) (B). CXCR3 expression was assessed in melanoma and lung. All phenotypic expression was assessed using flow cytometry post pre-REP. TCM=central memory, TSCM= stem cell memory, TEMRA (effector T cells), TEM=effector memory.
- [00173] Figure 72A-72C:** TIL derived from (A) melanoma (n=4) and (B) lung (n=5) were assessed for CD107a+ expression in response to PMA stimulation for 4 hours in the CD4+ and CD8+ cells, by flow cytometry. (C) pre-REP TIL (n=5) were stimulated for 24 hours with soluble OKT3 (30ng/ml) and the supernatants assessed for IFN $\gamma$  by ELISA.
- [00174] Figure 73A-73B:** The TCRv $\beta$  repertoire (24 specificities) were assessed in the TIL derived from melanoma (A) and lung (B) using the Beckman Coulter kit for flow cytometry.
- [00175] Figure 74:** Cryopreserved TIL exemplary manufacturing process (~22 days).
- [00176] Figure 75A-75B:** On Day 22 the volume reduced cell product is pooled and sampled to determine culture performance prior to wash and formulation. Samples are analyzed on the NC-200 automated cell counter as previously described. Total viable cell density is determined by the grand mean of duplicate counts from 4 independent samples. The Generation 2 (Gen 2) process yields a TIL product of similar dose to Generation 1 (Gen 1; the Gen 1 mean =  $4.10 \times 10^{10} \pm 2.92 \times 10^{10}$ , Gen 2 mean =  $3.12 \times 10^{10} \pm 2.19 \times 10^{10}$ ). B) Fold expansion is calculated for the REP phase as the dividend of the final viable cell density over the initial viable TIL seeding density. Gen 2 TIL products have a lower fold expansion relative to Gen 1 (Gen 1 mean =  $1.40 \times 10^3 \pm 9.86 \times 10^2$ , Gen 2 mean =  $5.11 \times 10^2 \pm 2.95 \times 10^2$ ).
- [00177] Figure 76:** Fresh formulated drug products were assayed for identity by flow cytometry for release. Gen 1 and Gen 2 processes produce highly purity T-cell cultures as defined by CD45, CD3 double positive phenotype (Gen1 #  $\pm$  SD, Gen 2 #  $\pm$  SD). P-value was calculated using Mann-Whitney 't' test.
- [00178] Figure 77:** Cryo preserved satellite vials of formulated drug product were thawed and assayed for extended phenotype by flow cytometry as previously described. Gen 1 and Gen 2 products express similar ratios of CD8 to CD4 T-cell subtypes. P-value was calculated using Mann-Whitney 't' test.
- [00179] Figure 78:** Cryo preserved satellite vials of formulated drug product were thawed and assayed for extended phenotype by flow cytometry as previously described. Gen 1 and

Gen 2 products express similar levels of costimulatory molecules CD27 and CD28 on T-cell subsets. P value was calculated using Mann-Whitney 't' test. Costimulatory molecules such as CD27 and CD28 are required to supply secondary and tertiary signaling necessary for effector cell proliferation upon T-cell receptor engagement.

5 [00180] **Figure 79:** Flow-FISH technology was used to measure the average length of the Telomere repeat as previously described. The above RTL value indicates that the average telomere fluorescence per chromosome/genome in Gen 1 (an embodiment of process 1C) is # %  $\pm$  SD%, and Gen 2 is #%  $\pm$  SD% of the telomere fluorescence per chromosome/genome in the control cells line (1301 Leukemia cell line). Data indicate that Gen 2 products on average  
10 have at least comparable telomere lengths to Gen 1 products. Telomere length is a surrogate measure of the length of *ex vivo* cell culture.

[00181] **Figure 80:** Gen 2 (an embodiment of the process 2A) drug products exhibit and increased capability of producing IFN- $\gamma$  relative to Gen 1 drug products. The ability of the drug product to be reactivated and secrete cytokine is a surrogate measure of in-vivo function  
15 upon TCR binding to cognate antigen in the context of HLA.

[00182] **Figure 81:** T-cell receptor diversity: RNA from  $10 \times 10^6$  TIL from Gen 1 (an embodiment of the process 1C) and Gen 2 (an embodiment of the process 2A) drug products were assayed to determine the total number and frequency of unique CDR3 sequences present in each product. A) The total number of unique CDR3 sequences present in each  
20 product ( Gen 1 n=#, mean  $\pm$  SD, Gen 2 n =#, mean  $\pm$  SD). B) Unique CDR3 sequences were indexed relative to frequency in each product to yield a score representative of the relative diversity of T-cell receptors in the product. TIL products from both processes are composed of polyclonal populations of T-cells with different antigen specificities and avidities. The breadth of the total T-cell repertoire may be indicative of the number of  
25 actionable epitopes on tumor cells.

[00183] **Figure 82:** Shows a diagram of an embodiment of process 2A, a 22-day process for TIL manufacturing.

[00184] **Figure 83:** Comparison table of Steps A through F from exemplary embodiments of process 1C and process 2A.

30 [00185] **Figure 84:** Detailed comparison of an embodiment of process 1C and an embodiment of process 2A.

[00186] **Figure 85:** Detailed scheme of an embodiment of a TIL therapy process.

[00187] **Figures 86A-86C:** Phenotypic characterization of TIL products using 10-color flow cytometry assay. (A) Percentage of T-cell and non-T-cell subsets is defined by CD45<sup>+</sup>CD3<sup>+</sup> and CD45<sup>-</sup>(non-lymphocyte)/CD45<sup>+</sup>CD3<sup>-</sup> (non-T-cell lymphocyte),

5 respectively. Overall, >99% of the TIL products tested consisted of T-cell (CD45<sup>+</sup>CD3<sup>+</sup>). Shown is an average of TIL products (n=10). (B) Percentage of two T-cell subsets including CD45<sup>+</sup>CD3<sup>+</sup>CD8<sup>+</sup> (blue open circle) and CD45<sup>+</sup>CD3<sup>+</sup>CD4<sup>+</sup> (pink open circle). No statistical difference in percentage of both subsets is observed using student's unpaired T test (P=0.68). (C) Non-T-cell population was characterized for four different subsets including: 1) Non-

10 lymphocyte (CD45<sup>-</sup>), 2) NK cell (CD45<sup>+</sup>CD3<sup>-</sup>CD16<sup>+</sup>/56<sup>+</sup>), 3) B-cell (CD45<sup>+</sup>CD19<sup>+</sup>), and 4) Non-NK/B-cell (CD45<sup>+</sup>CD3<sup>-</sup>CD16<sup>-</sup>CD56<sup>-</sup>CD19<sup>-</sup>).

[00188] **Figures 87A- 87B:** Characterization of T-cell subsets in CD45<sup>+</sup>CD3<sup>+</sup>CD4<sup>+</sup> and CD45<sup>+</sup>CD3<sup>+</sup>CD8<sup>+</sup> cell populations. Naïve, central memory (TCM), effector memory (TEF), and effector memory RA+(EMRA) T-cell subsets were defined using CD45RA and CCR7.

15 Figures show representative T-cell subsets from 10 final TIL products in both CD4<sup>+</sup> (A), and CD8<sup>+</sup> (B) cell populations. Effector memory T-cell subset (blue open circle) is a major population (>93%) in both CD4<sup>+</sup> and CD8<sup>+</sup> subsets of TIL final product. Less than 7% of the TIL products cells is central memory subset (pink open circle). EMRA (gray open circle) and naïve (black open circle) subsets are barely detected in TIL product (<0.02%). p values

20 represent the difference between EM and CM using student's unpaired T test

[00189] **Figures 88A-88B:** Detection of MCSP and EpCAM expression in melanoma tumor cells. Melanoma tumor cell lines (WM35, 526, and 888), patient-derived melanoma cell lines (1028, 1032, and 1041), and a colorectal adenoma carcinoma cell line (HT29 as a negative control) were characterized by staining for MCSP (melanoma-associated chondroitin sulfate

25 proteoglycan) and EpCAM (epithelial cell adhesion molecule) markers. (A) Average of 90% of melanoma tumor cells express MCSP. (B) EpCAM expression was not detected in melanoma tumor cell lines as compared positive control HT29, an EpCAM<sup>+</sup> tumor cell line.

[00190] **Figures 89A-89B:** Detection of spiked controls for the determination of tumor detection accuracy. The assay was performed by spiking known amounts of tumor cells into

30 PBMC suspensions (n=10). MCSP+526 melanoma tumor cells were diluted at ratios of 1:10, 1:100, and 1:1,000, then mixed with PBMC and stained with anti-MCSP and anti-CD45 antibodies and live/dead dye and analyzed by flow cytometry. (A) Approximately 3000, 300,

and 30 cells were detected in the dilution of 1:10, 1:100, and 1:1000, respectively. (B) An average (AV) and standard deviation (SD) of cells acquired in each condition was used to define the upper and lower reference limits.

**[00191] Figures 90A-90B:** Repeatability study of upper and lower limits in spiked controls.

5 Three independent experiments were performed in triplicate to determine the repeatability of spiking assay. (A) The number of MCSP<sup>+</sup> detected tumor cells were consistently within the range of upper and lower reference limits. (B) Linear regression plot demonstrates the correlation between MCSP<sup>+</sup> cells and spiking dilutions ( $R^2=0.99$ ) with the black solid line showing the best fit. The green and gray broken lines represent the 95% prediction limits in  
10 standard curve and samples (Exp#1 to 3), respectively.

**[00192] Figures 91A-91B:** Detection of residual melanoma tumor in TIL products. TIL products were assessed for residual tumor contamination using the developed assay (n=15). (A and B) The median number and percentage of detectable MCSP<sup>+</sup> events was 2 and 0.0002%, respectively.

15 **[00193] Figure 92:** Potency assessment of TIL products following T-cell activation. IFN $\gamma$  secretion after re-stimulation with anti-CD3/CD28/CD137 in TIL products assessed by ELISA in duplicate (n=5). IFN $\gamma$  secretion by the TIL products was significantly greater than unstimulated controls using Wilcoxon signed rank test ( $P=0.02$ ), and consistently >1000 pg/ml. IFN $\gamma$  secretion >200 pg/ml is considered to be potent. p value <0.05 is considered  
20 statistically significant.

**[00194] Figure 93:** Depiction of an embodiment of a cryopreserved TIL manufacturing process (22 days).

**[00195] Figure 94:** Table of process improvements from Gen 1 to Gen 2.

**[00196] Figures 95A-95C:** Total viable cells, growth rate, and viability. On Day 22 the  
25 volume reduced cell product is pooled and sampled to determine culture performance prior to wash and formulation. (A) Samples are analyzed on the NC-200 automated cell counter as previously described. Total viable cell density is determined by the grand mean of duplicate counts from 4 independent samples. The Gen 2 process yields a TIL product of similar dose to Gen 1 (Gen 1 mean =  $4.10 \times 10^{10} \pm 2.8 \times 10^{10}$ , Gen 2 mean =  $4.12 \times 10^{10} \pm 2.5 \times 10^{10}$ ). (B) The  
30 growth rate is calculated for the REP phase as  $gr = \ln(N(t)/N(0))/t$ . (C) Cell viability was assessed from 9 process development lots using the Cellometer K2 as previously described.

No significant decrease in cell viability was observed following a single freeze-thaw cycle of the formulated product. Average reduction in viability upon thaw and sampling is 2.19%.

- 5 **[00197] Figures 96A-96C:** Gen 2 products are highly pure T-cell cultures which express costimulatory molecules at levels comparable to Gen 1. (A) Fresh formulated drug products were assayed for identity by flow cytometry for release. Gen 1 and Gen 2 processes produce high purity T-cell cultures as defined by CD45+,CD3+ (double positive) phenotype. (B & C) Cryopreserved satellite vials of formulated drug product were thawed and assayed for extended phenotype by flow cytometry as previously described. Gen 1 and Gen 2 products express similar levels of costimulatory molecules CD27 and CD28 on T-cell subsets.
- 10 Costimulatory molecules such as CD27 and CD28 are required to supply secondary and tertiary signaling necessary for effector cell proliferation upon T-cell receptor engagement. P-value was calculated using Mann-Whitney 't' test.

**[00198] Figure 97:** Gen 2 products exhibit similar telomere lengths. However, some TIL populations may trend toward longer relative telomere.

- 15 **[00199] Figure 98:** Gen 2 drug products secrete IFN $\gamma$  in response to CD3, CD28, and CD137 engagement.

- [00200] Figures 99A-99B:** T-cell receptor diversity. (A) Unique CDR3 sequences were indexed relative to frequency in each product to yield a score representative of the overall diversity of T-cell receptors in the product. (B) The average total number of unique CDR3
- 20 sequences present in each infusion product.

**[00201] Figure 100:** An embodiment of a TIL manufacturing process of the present invention.

**[00202] Figure 101:** Enhancement in expansion during the pre-REP with IL-2/IL-15/IL-21 in multiple tumor histologies.

- 25 **[00203] Figures 102A-102B:** IL-2/IL-15/IL-21 enhanced the percentage of CD8+ cells in lung carcinoma, but not in melanoma. TIL derived from (A) melanoma (n=4), and (B) lung (n=7) were assessed phenotypically for CD4+ and CD8+ cells using flow cytometry post pre-REP.

- 30 **[00204] Figures 103A-103B:** Expression of CD27 was slightly enhanced in CD8+ cells in cultures treated with IL-2/IL-15/IL-21. TIL derived from (A) melanoma (n=4), and (B) lung

(n=7) were assessed phenotypically for CD27+ and CD28+ in the CD4+ and CD8+ cells using flow cytometry post pre-REP.

5 [00205] **Figures 104A-104B:** T cell subsets were unaltered with the addition of IL-15/IL-21. TIL were assessed phenotypically for effector/memory subsets (CD45RA and CCR7) in the CD8+ and CD4+ (data not shown) cells from (A) melanoma (n=4), and (B) lung (n=8) via flow cytometry post pre-REP.

10 [00206] **Figures 105A-105C:** Functional capacity of TIL was differentially enhanced with IL-2/IL-15/IL-21. TIL derived from (A) melanoma (n=4) and (B) lung (n=5) were assessed for CD107a+ expression in response to PMA stimulation for 4 hours in the CD4+ and CD8+ cells, by flow cytometry. (C) pre-REP TIL derived from melanoma and lung were stimulated for 24 hours with soluble anti-CD3 antibody and the supernatants assessed for IFN $\gamma$  by ELISA.

15 [00207] **Figures 106A-106B:** The TCR $\nu\beta$  repertoire (24 specificities) were assessed in the TIL derived from a (A) melanoma and (B) lung tumor using the Beckman Coulter kit for flow cytometry.

[00208] **Figure 107:** Scheme of Gen 2 cryopreserved LN-144 manufacturing process.

[00209] **Figure 108:** Scheme of study design of multicenter phase 2 clinical trial of novel cryopreserved TILs administered to patients with metastatic melanoma.

20 [00210] **Figure 109:** Table illustrating the Comparison Patient Characteristics from Cohort 1 (ASCO 2017) vs Cohort 2.

[00211] **Figure 110:** Table illustrating treatment emergent adverse events ( $\geq 30\%$ ).

[00212] **Figure 111:** Efficacy of the infusion product and TIL therapy.

[00213] **Figure 112:** Clinical status of response evaluable patients with SD or a better response.

25 [00214] **Figure 113:** Percent change in sum of diameters.

[00215] **Figure 114:** An increase of HMGB1 level was observed upon TIL treatment.

[00216] **Figure 115:** An increase in the biomarker IL-10 was observed post-LN-144 infusion.

- [00217] **Figure 116:** Updated patient characteristics for Cohort 2 of the phase 2 clinical trial in metastatic melanoma from the second data cut (N = 17 patients).
- [00218] **Figure 117:** Treatment emergent adverse events for Cohort 2 ( $\geq 30\%$ ) from the second data cut (N = 17 patients).
- 5 [00219] **Figure 118:** Time to response for evaluable patients (stable disease or better) in Cohort 2 from the second data cut (N = 17 patients). Of the 10 patients in the efficacy set, one patient (Patient 10) was not evaluable due to a melanoma-related death prior to the first tumor assessment not represented on the figure.
- [00220] **Figure 119:** Updated efficacy data for Cohort 2 from the second data cut (N = 17  
10 patients). The mean number of TILs infused is  $34 \times 10^9$ . The median number of prior therapies was 4.5. Patients with a BRAF mutation responded as well as patients with wild-type BRAF (a \* refers to patients with a BRAF mutation). One patient (Patient 10) was not evaluable due to a melanoma-related death prior to the first tumor assessment but was still considered in the efficacy set. Abbreviations: PR, partial response; SD, stable disease; PD,  
15 progressive disease.
- [00221] **Figure 120:** Updated efficacy data for evaluable patients from Cohort 2 from the second data cut (N = 17 patients). The \* indicates a non-evaluable patient that did not reach the first assessment. All efficacy-evaluable patients had received prior anti-PD-1 and anti-CTLA-4 checkpoint inhibitor therapies.
- 20 [00222] **Figure 121:** Representative computed tomography scan of a patient (003-015) with a PR from Cohort 2, second data cut.
- [00223] **Figure 122:** Correlation of IFN- $\gamma$  induction by TIL product prior to infusion with clinical reduction in tumor size on Day 42 post TIL infusion.
- [00224] **Figure 123:** IP-10 (CXCL10) levels (pg/mL,  $\log_{10}$ ) pre- and post-infusion of an  
25 embodiment of Gen 2 TIL product. IP-10 is a marker of cell adhesion and homing.
- [00225] **Figure 124:** IP-10 (CXCL10) levels (pg/mL,  $\log_{10}$ ) pre- and post-infusion of an embodiment of Gen 1 TIL product.
- [00226] **Figure 125:** MCP-1 levels (pg/mL,  $\log_{10}$ ) pre- and post-infusion of an embodiment of Gen 2 TIL product. MCP-1 is a marker of cell adhesion and homing.

[00227] **Figure 126:** MCP-1 levels (pg/mL, log<sub>10</sub>) pre- and post-infusion of an embodiment of Gen 1 TIL product.

[00228] **Figure 127:** Data from Phase 2 studies in cervical carcinoma and head and neck squamous cell carcinoma (HNSCC). SD = stable disease. PR = progressive disease. PR =  
5 partial response.

### BRIEF DESCRIPTION OF THE SEQUENCE LISTING

[00229] SEQ ID NO:1 is the amino acid sequence of the heavy chain of muromonab.

[00230] SEQ ID NO:2 is the amino acid sequence of the light chain of muromonab.

10 [00231] SEQ ID NO:3 is the amino acid sequence of a recombinant human IL-2 protein.

[00232] SEQ ID NO:4 is the amino acid sequence of aldesleukin.

[00233] SEQ ID NO:5 is the amino acid sequence of a recombinant human IL-4 protein.

[00234] SEQ ID NO:6 is the amino acid sequence of a recombinant human IL-7 protein.

[00235] SEQ ID NO:7 is the amino acid sequence of a recombinant human IL-15 protein.

15 [00236] SEQ ID NO:8 is the amino acid sequence of a recombinant human IL-21 protein.

### DETAILED DESCRIPTION OF THE INVENTION

#### I. Introduction

[00237] Adoptive cell therapy utilizing TILs cultured *ex vivo* by the Rapid Expansion Protocol (REP) has produced successful adoptive cell therapy following host  
20 immunosuppression in patients with melanoma. Current infusion acceptance parameters rely on readouts of the composition of TILs (*e.g.*, CD28, CD8, or CD4 positivity) and on the numerical folds of expansion and viability of the REP product.

[00238] Current REP protocols give little insight into the health of the TIL that will be infused into the patient. T cells undergo a profound metabolic shift during the course of their  
25 maturation from naïve to effector T cells (see Chang, *et al.*, *Nat. Immunol.* **2016**, *17*, 364, hereby expressly incorporated in its entirety, and in particular for the discussion and markers of anaerobic and aerobic metabolism). For example, naïve T cells rely on mitochondrial respiration to produce ATP, while mature, healthy effector T cells such as TIL are highly

glycolytic, relying on aerobic glycolysis to provide the bioenergetics substrates they require for proliferation, migration, activation, and anti-tumor efficacy.

[00239] Previous papers report that limiting glycolysis and promoting mitochondrial metabolism in TILs prior to transfer is desirable as cells that are relying heavily on glycolysis will suffer nutrient deprivation upon adoptive transfer which results in a majority of the transferred cells dying. Thus, the art teaches that promoting mitochondrial metabolism might promote in vivo longevity and in fact suggests using inhibitors of glycolysis before induction of the immune response. See Chang et al. (Chang, et al., *Nat. Immunol.* **2016**, 17(364);,

[00240] The present invention is further directed in some embodiments to methods for evaluating and quantifying this increase in metabolic health. Thus, the present invention provides methods of assaying the relative health of a TIL population using one or more general evaluations of metabolism, including, but not limited to, rates and amounts of glycolysis, oxidative phosphorylation, spare respiratory capacity (SRC), and glycolytic reserve.

[00241] Furthermore, the present invention is further directed in some embodiments to methods for evaluating and quantifying this increase in metabolic health. Thus, the present invention provides methods of assaying the relative health of a TIL population using one or more general evaluations of metabolism, including, but not limited to, rates and amounts of glycolysis, oxidative phosphorylation, spare respiratory capacity (SRC), and glycolytic reserve.

[00242] In addition, optional additional evaluations include, but are not limited to, ATP production, mitochondrial mass and glucose uptake.

## II. Definitions

[00243] Unless defined otherwise, all technical and scientific terms used herein have the same meaning as is commonly understood by one of skill in the art to which this invention belongs. All patents and publications referred to herein are incorporated by reference in their entireties.

[00244] The term “*in vivo*” refers to an event that takes place in a subject's body.

[00245] The term “*in vitro*” refers to an event that takes place outside of a subject’s body. In vitro assays encompass cell-based assays in which cells alive or dead are employed and may also encompass a cell-free assay in which no intact cells are employed.

5 [00246] The term “*ex vivo*” refers to an event which involves treating or performing a procedure on a cell, tissue and/or organ which has been removed from a subject’s body. Aptly, the cell, tissue and/or organ may be returned to the subject’s body in a method of surgery or treatment.

10 [00247] The term “rapid expansion” means an increase in the number of antigen-specific TILs of at least about 3-fold (or 4-, 5-, 6-, 7-, 8-, or 9-fold) over a period of a week, more preferably at least about 10-fold (or 20-, 30-, 40-, 50-, 60-, 70-, 80-, or 90-fold) over a period of a week, or most preferably at least about 100-fold over a period of a week. A number of rapid expansion protocols are outlined below.

15 [00248] By “tumor infiltrating lymphocytes” or “TILs” herein is meant a population of cells originally obtained as white blood cells that have left the bloodstream of a subject and migrated into a tumor. TILs include, but are not limited to, CD8<sup>+</sup> cytotoxic T cells (lymphocytes), Th1 and Th17 CD4<sup>+</sup> T cells, natural killer cells, dendritic cells and M1 macrophages. TILs include both primary and secondary TILs. “Primary TILs” are those that are obtained from patient tissue samples as outlined herein (sometimes referred to as “freshly harvested”), and “secondary TILs” are any TIL cell populations that have been expanded or  
20 proliferated as discussed herein, including, but not limited to bulk TILs and expanded TILs (“REP TILs” or “post-REP TILs”). TIL cell populations can include genetically modified TILs.

25 [00249] By “population of cells” (including TILs) herein is meant a number of cells that share common traits. In general, populations generally range from  $1 \times 10^6$  to  $1 \times 10^{10}$  in number, with different TIL populations comprising different numbers. For example, initial growth of primary TILs in the presence of IL-2 results in a population of bulk TILs of roughly  $1 \times 10^8$  cells. REP expansion is generally done to provide populations of  $1.5 \times 10^9$  to  $1.5 \times 10^{10}$  cells for infusion.

30 [00250] By “cryopreserved TILs” herein is meant that TILs, either primary, bulk, or expanded (REP TILs), are treated and stored in the range of about -150°C to -60°C. General methods for cryopreservation are also described elsewhere herein, including in the Examples.

For clarity, “cryopreserved TILs” are distinguishable from frozen tissue samples which may be used as a source of primary TILs.

**[00251]** By “thawed cryopreserved TILs” herein is meant a population of TILs that was previously cryopreserved and then treated to return to room temperature or higher, including  
5 but not limited to cell culture temperatures or temperatures wherein TILs may be administered to a patient.

**[00252]** TILs can generally be defined either biochemically, using cell surface markers, or functionally, by their ability to infiltrate tumors and effect treatment. TILs can be generally categorized by expressing one or more of the following biomarkers: CD4, CD8, TCR  $\alpha\beta$ ,  
10 CD27, CD28, CD56, CCR7, CD45Ra, CD95, PD-1, and CD25. Additionally and alternatively, TILs can be functionally defined by their ability to infiltrate solid tumors upon reintroduction into a patient.

**[00253]** The term “cryopreservation media” or “cryopreservation medium” refers to any medium that can be used for cryopreservation of cells. Such media can include media  
15 comprising 7% to 10% DMSO. Exemplary media include CryoStor CS10, Hyperthermasol, as well as combinations thereof. The term “CS10” refers to a cryopreservation medium which is obtained from Stemcell Technologies or from Biolife Solutions. The CS10 medium may be referred to by the trade name “CryoStor® CS10”. The CS10 medium is a serum-free, animal component-free medium which comprises DMSO.

**[00254]** The term “central memory T cell” refers to a subset of T cells that in the human are CD45R0+ and constitutively express CCR7 (CCR7<sup>hi</sup>) and CD62L (CD62<sup>hi</sup>). The surface  
20 phenotype of central memory T cells also includes TCR, CD3, CD127 (IL-7R), and IL-15R. Transcription factors for central memory T cells include BCL-6, BCL-6B, MBD2, and BMI1. Central memory T cells primarily secrete IL-2 and CD40L as effector molecules after  
25 TCR triggering. Central memory T cells are predominant in the CD4 compartment in blood, and in the human are proportionally enriched in lymph nodes and tonsils.

**[00255]** The term “effector memory T cell” refers to a subset of human or mammalian T cells that, like central memory T cells, are CD45R0+, but have lost the constitutive  
30 expression of CCR7 (CCR7<sup>lo</sup>) and are heterogeneous or low for CD62L expression (CD62L<sup>lo</sup>). The surface phenotype of central memory T cells also includes TCR, CD3, CD127 (IL-7R), and IL-15R. Transcription factors for central memory T cells include

BLIMP1. Effector memory T cells rapidly secrete high levels of inflammatory cytokines following antigenic stimulation, including interferon- $\gamma$ , IL-4, and IL-5. Effector memory T cells are predominant in the CD8 compartment in blood, and in the human are proportionally enriched in the lung, liver, and gut. CD8<sup>+</sup> effector memory T cells carry large amounts of perforin.

5 [00256] The term “closed system” refers to a system that is closed to the outside environment. Any closed system appropriate for cell culture methods can be employed with the methods of the present invention. Closed systems include, for example, but are not limited to closed G-containers. Once a tumor segment is added to the closed system, the  
10 system is no opened to the outside environment until the TILs are ready to be administered to the patient.

[00257] The terms “fragmenting,” “fragment,” and “fragmented,” as used herein to describe processes for disrupting a tumor, includes mechanical fragmentation methods such as crushing, slicing, dividing, and morcellating tumor tissue as well as any other method for  
15 disrupting the physical structure of tumor tissue.

[00258] The terms “peripheral blood mononuclear cells” and “PBMCs” refers to a peripheral blood cell having a round nucleus, including lymphocytes (T cells, B cells, NK cells) and monocytes. Preferably, the peripheral blood mononuclear cells are irradiated allogeneic peripheral blood mononuclear cells. PBMCs are a type of antigen-presenting cell.

20 [00259] The term “anti-CD3 antibody” refers to an antibody or variant thereof, *e.g.*, a monoclonal antibody and including human, humanized, chimeric or murine antibodies which are directed against the CD3 receptor in the T cell antigen receptor of mature T cells. Anti-CD3 antibodies include OKT-3, also known as muromonab. Anti-CD3 antibodies also include the UHCT1 clone, also known as T3 and CD3 $\epsilon$ . Other anti-CD3 antibodies include,  
25 for example, oteelixizumab, teplizumab, and visilizumab.

[00260] The term “OKT-3” (also referred to herein as “OKT3”) refers to a monoclonal antibody or biosimilar or variant thereof, including human, humanized, chimeric, or murine antibodies, directed against the CD3 receptor in the T cell antigen receptor of mature T cells, and includes commercially-available forms such as OKT-3 (30 ng/mL, MACS GMP CD3  
30 pure, Miltenyi Biotech, Inc., San Diego, CA, USA) and muromonab or variants, conservative amino acid substitutions, glycoforms, or biosimilars thereof. The amino acid sequences of

the heavy and light chains of muromonab are given in Table 1 (SEQ ID NO:1 and SEQ ID NO:2). A hybridoma capable of producing OKT-3 is deposited with the American Type Culture Collection and assigned the ATCC accession number CRL 8001. A hybridoma capable of producing OKT-3 is also deposited with European Collection of Authenticated Cell Cultures (ECACC) and assigned Catalogue No. 86022706.

TABLE 1. Amino acid sequences of muromonab.

Identifier	Sequence (One-Letter Amino Acid Symbols)		
SEQ ID NO:1 Muromonab heavy chain	QVQLQQSGAE LARPGASVKM SCKASGYTFT RYTMHWVKQR PGQGLEWIGY INPSRGYTNV	60	
	NQKFKDKATL TTDKSSSTAY MQLSSLTSED SAVVYCARYY DDHYCLDYWG QGTTTLTVSSA	120	
	KTTAPSVYPL APVCGGTTGS SVTLGCLVKG YFPEPVTLTW NSGSLSSGVH TFPAVLQSDL	180	
	YTLSSSVTVT SSTWPSQSIT CNVAHPASST KVDKKIEPRP KSCDKTHTCP PCPAPELLGG	240	
	PSVFLFPPKP KDTLMISRTP EVTCVVVDVS HEDPEVKFNW YVDGVEVHNA KTKPREEQYN	300	
	STYRVVSVLT VLHQDWLNGK EYCKVSNKA LPAPIEKTIS KARGQPREPQ VYTLPPSRDE	360	
	LTKNQVSLTC LVKGFYPSDI AVEWESNGQP ENNYKTTTPV LDSDGSFFLY SKLTVDKSRW	420	
	QQGNVFSCSV MHEALHNHYT QKSLSLSPGK	450	
	SEQ ID NO:2 Muromonab light chain	QIVLTQSPAI MSASPGKVT MTCASASSVS YMNWYQQKSG TSPKRWIYDT SKLASGVPAH	60
	FRGSGSGTSY SLTISGMEAE DAATYYCQQW SSNPFTFGSG TKLEINRADT APTVSIFFPS	120	
SEQLTSGGAS VVCFLNMFYP KDINVKWKID GSERQNGVLN SWTDQDSKDS TYSMSSTLTL	180		
TKDEYERHNS YTCEATHKTS TSPIVKSFNR NEC	213		

[00261] The term "IL-2" (also referred to herein as "IL2") refers to the T cell growth factor known as interleukin-2, and includes all forms of IL-2 including human and mammalian forms, conservative amino acid substitutions, glycoforms, biosimilars, and variants thereof.

10 IL-2 is described, *e.g.*, in Nelson, *J. Immunol.* **2004**, *172*, 3983-88 and Malek, *Annu. Rev. Immunol.* **2008**, *26*, 453-79, the disclosures of which are incorporated by reference herein. The amino acid sequence of recombinant human IL-2 suitable for use in the invention is given in Table 2 (SEQ ID NO:3). For example, the term IL-2 encompasses human,

15 recombinant forms of IL-2 such as aldesleukin (PROLEUKIN, available commercially from multiple suppliers in 22 million IU per single use vials), as well as the form of recombinant IL-2 commercially supplied by CellGenix, Inc., Portsmouth, NH, USA (CELLGRO GMP) or ProSpec-Tany TechnoGene Ltd., East Brunswick, NJ, USA (Cat. No. CYT-209-b) and other commercial equivalents from other vendors. Aldesleukin (des-alanyl-1, serine-125 human

20 IL-2) is a nonglycosylated human recombinant form of IL-2 with a molecular weight of approximately 15 kDa. The amino acid sequence of aldesleukin suitable for use in the invention is given in Table 2 (SEQ ID NO:4). The term IL-2 also encompasses pegylated forms of IL-2, as described herein, including the pegylated IL2 prodrug NKTR-214, available from Nektar Therapeutics, South San Francisco, CA, USA. NKTR-214 and pegylated IL-2 suitable for use in the invention is described in U.S. Patent Application Publication No. US

25 2014/0328791 A1 and International Patent Application Publication No. WO 2012/065086 A1,

the disclosures of which are incorporated by reference herein. Alternative forms of conjugated IL-2 suitable for use in the invention are described in U.S. Patent Nos. 4,766,106, 5,206,344, 5,089,261 and 4902,502, the disclosures of which are incorporated by reference herein. Formulations of IL-2 suitable for use in the invention are described in U.S. Patent No. 6,706,289, the disclosure of which is incorporated by reference herein.

TABLE 2. Amino acid sequences of interleukins.

Identifier	Sequence (One-Letter Amino Acid Symbols)	
SEQ ID NO:3 recombinant human IL-2 (rhIL-2)	MAPTSSSTKK TQLQLEHLLL DLQMILNGIN NYKNPKLTRM LTFKFYMPKK ATELKHLQCL EEELKPLEEV LNLAQSKNFH LRPDLISNI NVIVLELKGK ETTFMCEYAD ETATIVEFLN RWITFCQSII STLT	60 120 134
SEQ ID NO:4 Aldesleukin	PTSSSTKKTQ LQLEHLLLDL QMILNGINNY KNPKLTRMLT FKFYMPKKAT ELKHLQCLEE ELKPLEEVLN LAQSKNFHLR PRDLISNINV IVLELKGSET TFMCEYADET ATIVEFLNRW ITFSQSIIST LT	60 120 132
SEQ ID NO:5 recombinant human IL-4 (rhIL-4)	MHKCDITLQE IIKTLNSLTE QKTLCLETIV TDIFAASKNT TEKETFCRAA TVLRQFYSHH EKDTRCLGAT AQQFHRHKQL IRFLKRLDRN LWGLAGLNSC PVKEANQSTL ENFLERLKTI MREKYSKCSS	60 120 130
SEQ ID NO:6 recombinant human IL-7 (rhIL-7)	MDCDIEGKDG KQYESVLMVS IDQLLDSMKE IGSNCLNNEF NFFKRHCDA NKEGMFLFRA ARKLRQFLKM NSTGDFDLHL LKVSEGTTIL LNCTGQVKGR KPAALGEAQP TKSLEENKSL KEQKLLNDLC FLKRLQEI K TCWNKILMGT KEH	60 120 153
SEQ ID NO:7 recombinant human IL-15 (rhIL-15)	MNWNVISDL KKIEDLIQSM HIDATLYTES DVHPSCKVTA MKCFLELQV ISLESGDASI HDTVENLIIL ANNSLSSNGN VTESGCKECE ELEEKNIKEF LQSFVHIVQM FINTS	60 115
SEQ ID NO:8 recombinant human IL-21 (rhIL-21)	MQDRHMIRMRL QLIDIVDQLK NYVNDLVPEF LPAPEDVETN CEWSAFSCFQ KAQLKSANTG NNERIINVSI KKLKRKPPST NAGRRQKHL TCPSCDSYEK KPPKEFLERF KSLQKMIHQ HLSRTHGSE DS	60 120 132

[00262] The term "IL-4" (also referred to herein as "IL4") refers to the cytokine known as interleukin 4, which is produced by Th2 T cells and by eosinophils, basophils, and mast cells. IL-4 regulates the differentiation of naïve helper T cells (Th0 cells) to Th2 T cells. Steinke and Borish, *Respir. Res.* **2001**, *2*, 66-70. Upon activation by IL-4, Th2 T cells subsequently produce additional IL-4 in a positive feedback loop. IL-4 also stimulates B cell proliferation and class II MHC expression, and induces class switching to IgE and IgG<sub>1</sub> expression from B cells. Recombinant human IL-4 suitable for use in the invention is commercially available from multiple suppliers, including ProSpec-Tany TechnoGene Ltd., East Brunswick, NJ, USA (Cat. No. CYT-211) and ThermoFisher Scientific, Inc., Waltham, MA, USA (human IL-15 recombinant protein, Cat. No. Gibco CTP0043). The amino acid sequence of recombinant human IL-4 suitable for use in the invention is given in Table 2 (SEQ ID NO:5).

[00263] The term "IL-7" (also referred to herein as "IL7") refers to a glycosylated tissue-derived cytokine known as interleukin 7, which may be obtained from stromal and epithelial cells, as well as from dendritic cells. Fry and Mackall, *Blood* **2002**, *99*, 3892-904. IL-7 can

stimulate the development of T cells. IL-7 binds to the IL-7 receptor, a heterodimer consisting of IL-7 receptor alpha and common gamma chain receptor, which in a series of signals important for T cell development within the thymus and survival within the periphery. Recombinant human IL-7 suitable for use in the invention is commercially available from multiple suppliers, including ProSpec-Tany TechnoGene Ltd., East Brunswick, NJ, USA (Cat. No. CYT-254) and ThermoFisher Scientific, Inc., Waltham, MA, USA (human IL-15 recombinant protein, Cat. No. Gibco PHC0071). The amino acid sequence of recombinant human IL-7 suitable for use in the invention is given in Table 2 (SEQ ID NO:6).

**[00264]** The term “IL-15” (also referred to herein as “IL15”) refers to the T cell growth factor known as interleukin-15, and includes all forms of IL-2 including human and mammalian forms, conservative amino acid substitutions, glycoforms, biosimilars, and variants thereof. IL-15 is described, *e.g.*, in Fehniger and Caligiuri, *Blood* **2001**, *97*, 14-32, the disclosure of which is incorporated by reference herein. IL-15 shares  $\beta$  and  $\gamma$  signaling receptor subunits with IL-2. Recombinant human IL-15 is a single, non-glycosylated polypeptide chain containing 114 amino acids (and an N-terminal methionine) with a molecular mass of 12.8 kDa. Recombinant human IL-15 is commercially available from multiple suppliers, including ProSpec-Tany TechnoGene Ltd., East Brunswick, NJ, USA (Cat. No. CYT-230-b) and ThermoFisher Scientific, Inc., Waltham, MA, USA (human IL-15 recombinant protein, Cat. No. 34-8159-82). The amino acid sequence of recombinant human IL-15 suitable for use in the invention is given in Table 2 (SEQ ID NO:7).

**[00265]** The term “IL-21” (also referred to herein as “IL21”) refers to the pleiotropic cytokine protein known as interleukin-21, and includes all forms of IL-21 including human and mammalian forms, conservative amino acid substitutions, glycoforms, biosimilars, and variants thereof. IL-21 is described, *e.g.*, in Spolski and Leonard, *Nat. Rev. Drug. Disc.* **2014**, *13*, 379-95, the disclosure of which is incorporated by reference herein. IL-21 is primarily produced by natural killer T cells and activated human CD4<sup>+</sup> T cells. Recombinant human IL-21 is a single, non-glycosylated polypeptide chain containing 132 amino acids with a molecular mass of 15.4 kDa. Recombinant human IL-21 is commercially available from multiple suppliers, including ProSpec-Tany TechnoGene Ltd., East Brunswick, NJ, USA (Cat. No. CYT-408-b) and ThermoFisher Scientific, Inc., Waltham, MA, USA (human IL-21 recombinant protein, Cat. No. 14-8219-80). The amino acid sequence of recombinant human IL-21 suitable for use in the invention is given in Table 2 (SEQ ID NO:8).

[00266] When “an anti-tumor effective amount”, “an tumor-inhibiting effective amount”, or “therapeutic amount” is indicated, the precise amount of the compositions of the present invention to be administered can be determined by a physician with consideration of individual differences in age, weight, tumor size, extent of infection or metastasis, and condition of the patient (subject). It can generally be stated that a pharmaceutical composition comprising the tumor infiltrating lymphocytes (e.g. secondary TILs or genetically modified cytotoxic lymphocytes) described herein may be administered at a dosage of  $10^4$  to  $10^{11}$  cells/kg body weight (e.g.,  $10^5$  to  $10^6$ ,  $10^5$  to  $10^{10}$ ,  $10^5$  to  $10^{11}$ ,  $10^6$  to  $10^{10}$ ,  $10^6$  to  $10^{11}$ ,  $10^7$  to  $10^{11}$ ,  $10^7$  to  $10^{10}$ ,  $10^8$  to  $10^{11}$ ,  $10^8$  to  $10^{10}$ ,  $10^9$  to  $10^{11}$ , or  $10^9$  to  $10^{10}$  cells/kg body weight), including all integer values within those ranges. Tumor infiltrating lymphocytes (including in some cases, genetically modified cytotoxic lymphocytes) compositions may also be administered multiple times at these dosages. The tumor infiltrating lymphocytes (including in some cases, genetically) can be administered by using infusion techniques that are commonly known in immunotherapy (see, e.g., Rosenberg et al., *New Eng. J. of Med.* 319: 1676, 1988). The optimal dosage and treatment regime for a particular patient can readily be determined by one skilled in the art of medicine by monitoring the patient for signs of disease and adjusting the treatment accordingly.

[00267] The term “hematological malignancy” refers to mammalian cancers and tumors of the hematopoietic and lymphoid tissues, including but not limited to tissues of the blood, bone marrow, lymph nodes, and lymphatic system. Hematological malignancies are also referred to as “liquid tumors.” Hematological malignancies include, but are not limited to, acute lymphoblastic leukemia (ALL), chronic lymphocytic lymphoma (CLL), small lymphocytic lymphoma (SLL), acute myelogenous leukemia (AML), chronic myelogenous leukemia (CML), acute monocytic leukemia (AMoL), Hodgkin's lymphoma, and non-Hodgkin's lymphomas. The term “B cell hematological malignancy” refers to hematological malignancies that affect B cells.

[00268] The term “solid tumor” refers to an abnormal mass of tissue that usually does not contain cysts or liquid areas. Solid tumors may be benign or malignant. The term “solid tumor cancer” refers to malignant, neoplastic, or cancerous solid tumors. Solid tumor cancers include, but are not limited to, sarcomas, carcinomas, and lymphomas, such as cancers of the lung, breast, prostate, colon, rectum, and bladder. The tissue structure of solid tumors includes interdependent tissue compartments including the parenchyma (cancer cells) and the

supporting stromal cells in which the cancer cells are dispersed and which may provide a supporting microenvironment.

**[00269]** The term “liquid tumor” refers to an abnormal mass of cells that is fluid in nature. Liquid tumor cancers include, but are not limited to, leukemias, myelomas, and lymphomas, as well as other hematological malignancies. TILs obtained from liquid tumors may also be referred to herein as marrow infiltrating lymphocytes (MILs).

**[00270]** The term “microenvironment,” as used herein, may refer to the solid or hematological tumor microenvironment as a whole or to an individual subset of cells within the microenvironment. The tumor microenvironment, as used herein, refers to a complex mixture of “cells, soluble factors, signaling molecules, extracellular matrices, and mechanical cues that promote neoplastic transformation, support tumor growth and invasion, protect the tumor from host immunity, foster therapeutic resistance, and provide niches for dominant metastases to thrive,” as described in Swartz, *et al.*, *Cancer Res.*, **2012**, *72*, 2473. Although tumors express antigens that should be recognized by T cells, tumor clearance by the immune system is rare because of immune suppression by the microenvironment.

**[00271]** In an embodiment, the invention includes a method of treating a cancer with a population of TILs, wherein a patient is pre-treated with non-myeloablative chemotherapy prior to an infusion of TILs according to the invention. In some embodiments, the population of TILs may be provided wherein a patient is pre-treated with nonmyeloablative chemotherapy prior to an infusion of TILs according to the present invention. In an embodiment, the non-myeloablative chemotherapy is cyclophosphamide 60 mg/kg/d for 2 days (days 27 and 26 prior to TIL infusion) and fludarabine 25 mg/m<sup>2</sup>/d for 5 days (days 27 to 23 prior to TIL infusion). In an embodiment, after non-myeloablative chemotherapy and TIL infusion (at day 0) according to the invention, the patient receives an intravenous infusion of IL-2 intravenously at 720,000 IU/kg every 8 hours to physiologic tolerance.

**[00272]** Experimental findings indicate that lymphodepletion prior to adoptive transfer of tumor-specific T lymphocytes plays a key role in enhancing treatment efficacy by eliminating regulatory T cells and competing elements of the immune system (“cytokine sinks”). Accordingly, some embodiments of the invention utilize a lymphodepletion step (sometimes also referred to as “immunosuppressive conditioning”) on the patient prior to the introduction of the rTILs of the invention.

**[00273]** The terms “co-administration,” “co-administering,” “administered in combination with,” “administering in combination with,” “simultaneous,” and “concurrent,” as used herein, encompass administration of two or more active pharmaceutical ingredients (in a preferred embodiment of the present invention, for example, at least one potassium channel agonist in combination with a plurality of TILs) to a subject so that both active pharmaceutical ingredients and/or their metabolites are present in the subject at the same time. Co-administration includes simultaneous administration in separate compositions, administration at different times in separate compositions, or administration in a composition in which two or more active pharmaceutical ingredients are present. Simultaneous administration in separate compositions and administration in a composition in which both agents are present are preferred.

**[00274]** The term “effective amount” or “therapeutically effective amount” refers to that amount of a compound or combination of compounds as described herein that is sufficient to effect the intended application including, but not limited to, disease treatment. A therapeutically effective amount may vary depending upon the intended application (in vitro or in vivo), or the subject and disease condition being treated (e.g., the weight, age and gender of the subject), the severity of the disease condition, or the manner of administration. The term also applies to a dose that will induce a particular response in target cells (e.g., the reduction of platelet adhesion and/or cell migration). The specific dose will vary depending on the particular compounds chosen, the dosing regimen to be followed, whether the compound is administered in combination with other compounds, timing of administration, the tissue to which it is administered, and the physical delivery system in which the compound is carried.

**[00275]** The terms “treatment”, “treating”, “treat”, and the like, refer to obtaining a desired pharmacologic and/or physiologic effect. The effect may be prophylactic in terms of completely or partially preventing a disease or symptom thereof and/or may be therapeutic in terms of a partial or complete cure for a disease and/or adverse effect attributable to the disease. “Treatment”, as used herein, covers any treatment of a disease in a mammal, particularly in a human, and includes: (a) preventing the disease from occurring in a subject which may be predisposed to the disease but has not yet been diagnosed as having it; (b) inhibiting the disease, i.e., arresting its development or progression; and (c) relieving the disease, i.e., causing regression of the disease and/or relieving one or more disease

symptoms. "Treatment" is also meant to encompass delivery of an agent in order to provide for a pharmacologic effect, even in the absence of a disease or condition. For example, "treatment" encompasses delivery of a composition that can elicit an immune response or confer immunity in the absence of a disease condition, e.g., in the case of a vaccine.

[00276] The term "heterologous" when used with reference to portions of a nucleic acid or protein indicates that the nucleic acid or protein comprises two or more subsequences that are not found in the same relationship to each other in nature. For instance, the nucleic acid is typically recombinantly produced, having two or more sequences from unrelated genes arranged to make a new functional nucleic acid, e.g., a promoter from one source and a coding region from another source, or coding regions from different sources. Similarly, a heterologous protein indicates that the protein comprises two or more subsequences that are not found in the same relationship to each other in nature (e.g., a fusion protein).

[00277] The terms "sequence identity," "percent identity," and "sequence percent identity" (or synonyms thereof, e.g., "99% identical") in the context of two or more nucleic acids or polypeptides, refer to two or more sequences or subsequences that are the same or have a specified percentage of nucleotides or amino acid residues that are the same, when compared and aligned (introducing gaps, if necessary) for maximum correspondence, not considering any conservative amino acid substitutions as part of the sequence identity. The percent identity can be measured using sequence comparison software or algorithms or by visual inspection. Various algorithms and software are known in the art that can be used to obtain alignments of amino acid or nucleotide sequences. Suitable programs to determine percent sequence identity include for example the BLAST suite of programs available from the U.S. Government's National Center for Biotechnology Information BLAST web site.

Comparisons between two sequences can be carried using either the BLASTN or BLASTP algorithm. BLASTN is used to compare nucleic acid sequences, while BLASTP is used to compare amino acid sequences. ALIGN, ALIGN-2 (Genentech, South San Francisco, California) or MegAlign, available from DNASTAR, are additional publicly available software programs that can be used to align sequences. One skilled in the art can determine appropriate parameters for maximal alignment by particular alignment software. In certain embodiments, the default parameters of the alignment software are used.

[00278] As used herein, the term "variant" encompasses but is not limited to antibodies or fusion proteins which comprise an amino acid sequence which differs from the amino acid

sequence of a reference antibody by way of one or more substitutions, deletions and/or additions at certain positions within or adjacent to the amino acid sequence of the reference antibody. The variant may comprise one or more conservative substitutions in its amino acid sequence as compared to the amino acid sequence of a reference antibody. Conservative substitutions may involve, e.g., the substitution of similarly charged or uncharged amino acids. The variant retains the ability to specifically bind to the antigen of the reference antibody. The term variant also includes pegylated antibodies or proteins.

**[00279]** By “tumor infiltrating lymphocytes” or “TILs” herein is meant a population of cells originally obtained as white blood cells that have left the bloodstream of a subject and migrated into a tumor. TILs include, but are not limited to, CD8<sup>+</sup> cytotoxic T cells (lymphocytes), Th1 and Th17 CD4<sup>+</sup> T cells, natural killer cells, dendritic cells and M1  
5 macrophages. TILs include both primary and secondary TILs. “Primary TILs” are those that are obtained from patient tissue samples as outlined herein (sometimes referred to as “freshly harvested”), and “secondary TILs” are any TIL cell populations that have been expanded or proliferated as discussed herein, including, but not limited to bulk TILs, expanded TILs (“REP TILs”) as well as “reREP TILs” as discussed herein. reREP TILs can include for  
10 example second expansion TILs or second additional expansion TILs (such as, for example, those described in Step D of Figure 27, including TILs referred to as reREP TILs).

**[00280]** TILs can generally be defined either biochemically, using cell surface markers, or functionally, by their ability to infiltrate tumors and effect treatment. TILs can be generally categorized by expressing one or more of the following biomarkers: CD4, CD8, TCR αβ,  
15 CD27, CD28, CD56, CCR7, CD45Ra, CD95, PD-1, and CD25. Additionally, and alternatively, TILs can be functionally defined by their ability to infiltrate solid tumors upon reintroduction into a patient. TILs may further be characterized by potency – for example, TILs may be considered potent if, for example, interferon (IFN) release is greater than about 50 pg/mL, greater than about 100 pg/mL, greater than about 150 pg/mL, or greater than about  
20 200 pg/mL.

**[00281]** The terms “pharmaceutically acceptable carrier” or “pharmaceutically acceptable excipient” are intended to include any and all solvents, dispersion media, coatings, antibacterial and antifungal agents, isotonic and absorption delaying agents, and inert ingredients. The use of such pharmaceutically acceptable carriers or pharmaceutically  
25 acceptable excipients for active pharmaceutical ingredients is well known in the art. Except

insofar as any conventional pharmaceutically acceptable carrier or pharmaceutically acceptable excipient is incompatible with the active pharmaceutical ingredient, its use in the therapeutic compositions of the invention is contemplated. Additional active pharmaceutical ingredients, such as other drugs, can also be incorporated into the described compositions and methods.

5 [00282] The terms “about” and “approximately” mean within a statistically meaningful range of a value. Such a range can be within an order of magnitude, preferably within 50%, more preferably within 20%, more preferably still within 10%, and even more preferably within 5% of a given value or range. The allowable variation encompassed by the terms  
10 “about” or “approximately” depends on the particular system under study, and can be readily appreciated by one of ordinary skill in the art. Moreover, as used herein, the terms “about” and “approximately” mean that dimensions, sizes, formulations, parameters, shapes and other quantities and characteristics are not and need not be exact, but may be approximate and/or larger or smaller, as desired, reflecting tolerances, conversion factors, rounding off,  
15 measurement error and the like, and other factors known to those of skill in the art. In general, a dimension, size, formulation, parameter, shape or other quantity or characteristic is “about” or “approximate” whether or not expressly stated to be such. It is noted that embodiments of very different sizes, shapes and dimensions may employ the described arrangements.

20 [00283] The transitional terms “comprising,” “consisting essentially of,” and “consisting of,” when used in the appended claims, in original and amended form, define the claim scope with respect to what unrecited additional claim elements or steps, if any, are excluded from the scope of the claim(s). The term “comprising” is intended to be inclusive or open-ended and does not exclude any additional, unrecited element, method, step or material. The term  
25 “consisting of” excludes any element, step or material other than those specified in the claim and, in the latter instance, impurities ordinary associated with the specified material(s). The term “consisting essentially of” limits the scope of a claim to the specified elements, steps or material(s) and those that do not materially affect the basic and novel characteristic(s) of the claimed invention. All compositions, methods, and kits described herein that embody the  
30 present invention can, in alternate embodiments, be more specifically defined by any of the transitional terms “comprising,” “consisting essentially of,” and “consisting of.”

### III. TIL Manufacturing Processes

[00284] An exemplary TIL process known as process 2A containing some of these features is depicted in Figure 1, and some of the advantages of this embodiment of the present invention over process 1C are described in Figure 2, as does Figure 84. Process 1C is shown for comparison in Figure 3. Two alternative timelines for TIL therapy based on process 2A are shown in Figure 4 (higher cell counts) and Figure 5 (lower cell counts). An embodiment of process 2A is shown in Figure 6 as well as Figure 27. Figures 83 and 84 further provides an exemplary 2A process compared to an exemplary 1C process.

[00285] As discussed herein, the present invention can include a step relating to the restimulation of cryopreserved TILs to increase their metabolic activity and thus relative health prior to transplant into a patient, and methods of testing said metabolic health. As generally outlined herein, TILs are generally taken from a patient sample and manipulated to expand their number prior to transplant into a patient. In some embodiments, the TILs may be optionally genetically manipulated as discussed below.

[00286] In some embodiments, the TILs may be cryopreserved. Once thawed, they may also be restimulated to increase their metabolism prior to infusion into a patient.

[00287] In some embodiments, the first expansion (including processes referred to as the preREP as well as processes shown in Figure 27 as Step A) is shortened to 3 to 14 days and the second expansion (including processes referred to as the REP as well as processes shown in Figure 27 as Step B) is shorted to 7 to 14 days, as discussed in detail below as well as in the examples and figures. In some embodiments, the first expansion (for example, an expansion described as Step B in Figure 27) is shortened to 11 days and the second expansion (for example, an expansion as described in Step D in Figure 27) is shortened to 11 days, as discussed in the Examples and shown in Figures 4, 5 and 27. In some embodiments, the combination of the first expansion and second expansion (for example, expansions described as Step B and Step D in Figure 27) is shortened to 22 days, as discussed in detail below and in the examples and figures.

[00288] The “Step” Designations A, B, C, *etc.*, below are in reference to Figure 27 and in reference to certain embodiments described herein. The ordering of the Steps below and in Figure 27 is exemplary and any combination or order of steps, as well as additional steps,

repetition of steps, and/or omission of steps is contemplated by the present application and the methods disclosed herein.

**A. STEP A: Obtain Patient tumor sample**

5 [00289] In general, TILs are initially obtained from a patient tumor sample (“primary TILs”) and then expanded into a larger population for further manipulation as described herein, optionally cryopreserved, restimulated as outlined herein and optionally evaluated for phenotype and metabolic parameters as an indication of TIL health.

10 [00290] A patient tumor sample may be obtained using methods known in the art, generally via surgical resection, needle biopsy or other means for obtaining a sample that contains a mixture of tumor and TIL cells. In general, the tumor sample may be from any solid tumor, including primary tumors, invasive tumors or metastatic tumors. The tumor sample may also be a liquid tumor, such as a tumor obtained from a hematological malignancy. The solid tumor may be of any cancer type, including, but not limited to, breast, pancreatic, prostate, 15 colorectal, lung, brain, renal, stomach, and skin (including but not limited to squamous cell carcinoma, basal cell carcinoma, and melanoma). In some embodiments, useful TILs are obtained from malignant melanoma tumors, as these have been reported to have particularly high levels of TILs.

20 [00291] The term “solid tumor” refers to an abnormal mass of tissue that usually does not contain cysts or liquid areas. Solid tumors may be benign or malignant. The term “solid tumor cancer” refers to malignant, neoplastic, or cancerous solid tumors. Solid tumor cancers include, but are not limited to, sarcomas, carcinomas, and lymphomas, such as cancers of the lung, breast, triple negative breast cancer, prostate, colon, rectum, and bladder. In some 25 embodiments, the cancer is selected from cervical cancer, head and neck cancer (including, for example, head and neck squamous cell carcinoma (HNSCC)) glioblastoma, ovarian cancer, sarcoma, pancreatic cancer, bladder cancer, breast cancer, triple negative breast cancer, and non-small cell lung carcinoma. The tissue structure of solid tumors includes interdependent tissue compartments including the parenchyma (cancer cells) and the supporting stromal cells in which the cancer cells are dispersed and which may provide a 30 supporting microenvironment.

- [00292] The term “hematological malignancy” refers to mammalian cancers and tumors of the hematopoietic and lymphoid tissues, including but not limited to tissues of the blood, bone marrow, lymph nodes, and lymphatic system. Hematological malignancies are also referred to as “liquid tumors.” Hematological malignancies include, but are not limited to, acute lymphoblastic leukemia (ALL), chronic lymphocytic lymphoma (CLL), small lymphocytic lymphoma (SLL), acute myelogenous leukemia (AML), chronic myelogenous leukemia (CML), acute monocytic leukemia (AMoL), Hodgkin's lymphoma, and non-Hodgkin's lymphomas. The term “B cell hematological malignancy” refers to hematological malignancies that affect B cells.
- 10 [00293] Once obtained, the tumor sample is generally fragmented using sharp dissection into small pieces of between 1 to about 8 mm<sup>3</sup>, with from about 2-3 mm<sup>3</sup> being particularly useful. The TILs are cultured from these fragments using enzymatic tumor digests. Such tumor digests may be produced by incubation in enzymatic media (*e.g.*, Roswell Park Memorial Institute (RPMI) 1640 buffer, 2 mM glutamate, 10 mcg/mL gentamicine, 30 units/mL of DNase and 1.0 mg/mL of collagenase) followed by mechanical dissociation (*e.g.*, using a tissue dissociator). Tumor digests may be produced by placing the tumor in enzymatic media and mechanically dissociating the tumor for approximately 1 minute, followed by incubation for 30 minutes at 37 °C in 5% CO<sub>2</sub>, followed by repeated cycles of mechanical dissociation and incubation under the foregoing conditions until only small tissue
- 15 pieces are present. At the end of this process, if the cell suspension contains a large number of red blood cells or dead cells, a density gradient separation using FICOLL branched hydrophilic polysaccharide may be performed to remove these cells. Alternative methods known in the art may be used, such as those described in U.S. Patent Application Publication No. 2012/0244133 A1, the disclosure of which is incorporated by reference herein. Any of
- 20 the foregoing methods may be used in any of the embodiments described herein for methods of expanding TILs or methods treating a cancer.

[00294] In general, the harvested cell suspension is called a “primary cell population” or a “freshly harvested” cell population.

- [00295] In some embodiments, fragmentation includes physical fragmentation, including for example, dissection as well as digestion. In some embodiments, the fragmentation is physical fragmentation. In some embodiments, the fragmentation is dissection. In some embodiments, the fragmentation is by digestion. In some embodiments, TILs can be initially cultured from
- 30

enzymatic tumor digests and tumor fragments obtained from patients. In an embodiment, TILs can be initially cultured from enzymatic tumor digests and tumor fragments obtained from patients.

[00296] In some embodiments, where the tumor is a solid tumor, the tumor undergoes physical fragmentation after the tumor sample is obtained in, for example, Step A (as provided in Figure 27). In some embodiments, the fragmentation occurs before cryopreservation. In some embodiments, the fragmentation occurs after cryopreservation. In some embodiments, the fragmentation occurs after obtaining the tumor and in the absence of any cryopreservation. In some embodiments, the tumor is fragmented and 10, 20, 30, 40 or more fragments or pieces are placed in each container for the first expansion. In some embodiments, the tumor is fragmented and 30 or 40 fragments or pieces are placed in each container for the first expansion. In some embodiments, the tumor is fragmented and 40 fragments or pieces are placed in each container for the first expansion. In some embodiments, the multiple fragments comprise about 4 to about 50 fragments, wherein each fragment has a volume of about 27 mm<sup>3</sup>. In some embodiments, the multiple fragments comprise about 30 to about 60 fragments with a total volume of about 1300 mm<sup>3</sup> to about 1500 mm<sup>3</sup>. In some embodiments, the multiple fragments comprise about 50 fragments with a total volume of about 1350 mm<sup>3</sup>. In some embodiments, the multiple fragments comprise about 50 fragments with a total mass of about 1 gram to about 1.5 grams. In some embodiments, the multiple fragments comprise about 4 fragments.

[00297] In some embodiments, the TILs are obtained from tumor fragments. In some embodiments, the tumor fragment is obtained by sharp dissection. In some embodiments, the tumor fragment is between about 1 mm<sup>3</sup> and 10 mm<sup>3</sup>. In some embodiments, the tumor fragment is between about 1 mm<sup>3</sup> and 8 mm<sup>3</sup>. In some embodiments, the tumor fragment is about 1 mm<sup>3</sup>. In some embodiments, the tumor fragment is about 2 mm<sup>3</sup>. In some embodiments, the tumor fragment is about 3 mm<sup>3</sup>. In some embodiments, the tumor fragment is about 4 mm<sup>3</sup>. In some embodiments, the tumor fragment is about 5 mm<sup>3</sup>. In some embodiments, the tumor fragment is about 6 mm<sup>3</sup>. In some embodiments, the tumor fragment is about 7 mm<sup>3</sup>. In some embodiments, the tumor fragment is about 8 mm<sup>3</sup>. In some embodiments, the tumor fragment is about 9 mm<sup>3</sup>. In some embodiments, the tumor fragment is about 10 mm<sup>3</sup>.

[00298] In some embodiments, the TILs are obtained from tumor digests. In some  
embodiments, tumor digests were generated by incubation in enzyme media, for example but  
not limited to RPMI 1640, 2 mM GlutaMAX, 10 mg/mL gentamicin, 30 U/mL DNase, and  
1.0 mg/mL collagenase, followed by mechanical dissociation (GentleMACS, Miltenyi  
5 Biotec, Auburn, CA). After placing the tumor in enzyme media, the tumor can be  
mechanically dissociated for approximately 1 minute. The solution can then be incubated  
for 30 minutes at 37 °C in 5% CO<sub>2</sub> and it then mechanically disrupted again for  
approximately 1 minute. After being incubated again for 30 minutes at 37 °C in 5% CO<sub>2</sub>,  
the tumor can be mechanically disrupted a third time for approximately 1 minute. In some  
10 embodiments, after the third mechanical disruption if large pieces of tissue were present, 1  
or 2 additional mechanical dissociations were applied to the sample, with or without 30  
additional minutes of incubation at 37 °C in 5% CO<sub>2</sub>. In some embodiments, at the end of  
the final incubation if the cell suspension contained a large number of red blood cells or  
dead cells, a density gradient separation using Ficoll can be performed to remove these  
15 cells.

[00299] In some embodiments, the harvested cell suspension prior to the first expansion step  
is called a “primary cell population” or a “freshly harvested” cell population.

[00300] In some embodiments, cells can be optionally frozen after sample harvest and stored  
frozen prior to entry into the expansion described in Step B, which is described in further  
20 detail below, as well as exemplified in Figure 27.

## **B. STEP B: First Expansion**

### **1. Young TILs**

[00301] In some embodiments, the present methods provide for obtaining young TILs,  
25 which are capable of increased replication cycles upon administration to a subject/patient and  
as such may provide additional therapeutic benefits over older TILs (*i.e.*, TILs which have  
further undergone more rounds of replication prior to administration to a subject/patient).  
Features of young TILs have been described in the literature, for example Donia, et al.,  
*Scandinavian Journal of Immunology*, 75:157–167 (2012); Dudley et al., *Clin Cancer Res*,  
30 16:6122-6131 (2010); Huang et al., *J Immunother*, 28(3):258–267 (2005); Besser et al., *Clin  
Cancer Res*, 19(17):OF1-OF9 (2013); Besser et al., *J Immunother* 32:415–423 (2009);

Robbins, et al., *J Immunol* 2004; 173:7125-7130; Shen et al., *J Immunother*, 30:123-129 (2007); Zhou, et al., *J Immunother*, 28:53-62 (2005); and Tran, et al., *J Immunother*, 31:742-751 (2008), all of which are incorporated herein by reference in their entireties.

**[00302]** The diverse antigen receptors of T and B lymphocytes are produced by somatic recombination of a limited, but large number of gene segments. These gene segments: V (variable), D (diversity), J (joining), and C (constant), determine the binding specificity and downstream applications of immunoglobulins and T-cell receptors (TCRs). The present invention provides a method for generating TILs which exhibit and increase the T-cell repertoire diversity. In some embodiments, the TILs obtained by the present method exhibit an increase in the T-cell repertoire diversity. In some embodiments, the TILs obtained by the present method exhibit an increase in the T-cell repertoire diversity as compared to freshly harvested TILs and/or TILs prepared using other methods than those provide herein including for example, methods other than those embodied in Figure 27. In some embodiments, the TILs obtained by the present method exhibit an increase in the T-cell repertoire diversity as compared to freshly harvested TILs and/or TILs prepared using methods referred to as process 1C, as exemplified in Figure 83. In some embodiments, the TILs obtained in the first expansion exhibit an increase in the T-cell repertoire diversity. In some embodiments, the increase in diversity is an increase in the immunoglobulin diversity and/or the T-cell receptor diversity. In some embodiments, the diversity is in the immunoglobulin is in the immunoglobulin heavy chain. In some embodiments, the diversity is in the immunoglobulin is in the immunoglobulin light chain. In some embodiments, the diversity is in the T-cell receptor. In some embodiments, the diversity is in one of the T-cell receptors selected from the group consisting of alpha, beta, gamma, and delta receptors. In some embodiments, there is an increase in the expression of T-cell receptor (TCR) alpha and/or beta. In some embodiments, there is an increase in the expression of T-cell receptor (TCR) alpha. In some embodiments, there is an increase in the expression of T-cell receptor (TCR) beta. In some embodiments, there is an increase in the expression of TCRab (*i.e.*, TCR $\alpha/\beta$ ).

**[00303]** After dissection or digestion of tumor fragments, for example such as described in Step A of Figure 27, the resulting cells are cultured in serum containing IL-2 under conditions that favor the growth of TILs over tumor and other cells. In some embodiments, the tumor digests are incubated in 2 mL wells in media comprising inactivated human AB

serum with 6000 IU/mL of IL-2. This primary cell population is cultured for a period of days, generally from 3 to 14 days, resulting in a bulk TIL population, generally about  $1 \times 10^8$  bulk TIL cells. In some embodiments, this primary cell population is cultured for a period of 7 to 14 days, resulting in a bulk TIL population, generally about  $1 \times 10^8$  bulk TIL cells. In some embodiments, this primary cell population is cultured for a period of 10 to 14 days, resulting in a bulk TIL population, generally about  $1 \times 10^8$  bulk TIL cells. In some embodiments, this primary cell population is cultured for a period of about 11 days, resulting in a bulk TIL population, generally about  $1 \times 10^8$  bulk TIL cells.

**[00304]** In a preferred embodiment, expansion of TILs may be performed using an initial bulk TIL expansion step (for example such as those described in Step B of Figure 27, which can include processes referred to as pre-REP) as described below and herein, followed by a second expansion (Step D, including processes referred to as rapid expansion protocol (REP) steps) as described below under Step D and herein, followed by optional cryopreservation, and followed by a second Step D (including processes referred to as restimulation REP steps) as described below and herein. The TILs obtained from this process may be optionally characterized for phenotypic characteristics and metabolic parameters as described herein.

**[00305]** In embodiments where TIL cultures are initiated in 24-well plates, for example, using Costar 24-well cell culture cluster, flat bottom (Corning Incorporated, Corning, NY, each well can be seeded with  $1 \times 10^6$  tumor digest cells or one tumor fragment in 2 mL of complete medium (CM) with IL-2 (6000 IU/mL; Chiron Corp., Emeryville, CA). In some embodiments, the tumor fragment is between about  $1 \text{ mm}^3$  and  $10 \text{ mm}^3$ .

**[00306]** In some embodiments, the first expansion culture medium is referred to as "CM", an abbreviation for culture media. In some embodiments, CM for Step B consists of RPMI 1640 with GlutaMAX, supplemented with 10% human AB serum, 25 mM HEPES, and 10 mg/mL gentamicin. In embodiments where cultures are initiated in gas-permeable flasks with a 40 mL capacity and a  $10 \text{ cm}^2$  gas-permeable silicon bottom (for example, G-Rex10; Wilson Wolf Manufacturing, New Brighton, MN) (Fig. 1), each flask was loaded with  $10\text{--}40 \times 10^6$  viable tumor digest cells or 5–30 tumor fragments in 10–40 mL of CM with IL-2. Both the G-Rex10 and 24-well plates were incubated in a humidified incubator at  $37^\circ\text{C}$  in 5%  $\text{CO}_2$  and 5 days after culture initiation, half the media was removed and replaced with fresh CM and IL-2 and after day 5, half the media was changed every 2–3 days.

[00307] After preparation of the tumor fragments, the resulting cells (*i.e.*, fragments) are cultured in serum containing IL-2 under conditions that favor the growth of TILs over tumor and other cells. In some embodiments, the tumor digests are incubated in 2 mL wells in media comprising inactivated human AB serum (or, in some cases, as outlined herein, in the presence of aAPC cell population) with 6000 IU/mL of IL-2. This primary cell population is cultured for a period of days, generally from 10 to 14 days, resulting in a bulk TIL population, generally about  $1 \times 10^8$  bulk TIL cells. In some embodiments, the growth media during the first expansion comprises IL-2 or a variant thereof. In some embodiments, the IL is recombinant human IL-2 (rhIL-2). In some embodiments the IL-2 stock solution has a specific activity of  $20\text{-}30 \times 10^6$  IU/mg for a 1 mg vial. In some embodiments the IL-2 stock solution has a specific activity of  $20 \times 10^6$  IU/mg for a 1 mg vial. In some embodiments the IL-2 stock solution has a specific activity of  $25 \times 10^6$  IU/mg for a 1 mg vial. In some embodiments the IL-2 stock solution has a specific activity of  $30 \times 10^6$  IU/mg for a 1 mg vial. In some embodiments, the IL-2 stock solution has a final concentration of  $4\text{-}8 \times 10^6$  IU/mg of IL-2. In some embodiments, the IL-2 stock solution has a final concentration of  $5\text{-}7 \times 10^6$  IU/mg of IL-2. In some embodiments, the IL-2 stock solution has a final concentration of  $6 \times 10^6$  IU/mg of IL-2. In some embodiments, the IL-2 stock solution is prepared as described in Example 4. In some embodiments, the first expansion culture media comprises about 10,000 IU/mL of IL-2, about 9,000 IU/mL of IL-2, about 8,000 IU/mL of IL-2, about 7,000 IU/mL of IL-2, about 6,000 IU/mL of IL-2 or about 5,000 IU/mL of IL-2. In some embodiments, the first expansion culture media comprises about 9,000 IU/mL of IL-2 to about 5,000 IU/mL of IL-2. In some embodiments, the first expansion culture media comprises about 8,000 IU/mL of IL-2 to about 6,000 IU/mL of IL-2. In some embodiments, the first expansion culture media comprises about 7,000 IU/mL of IL-2 to about 6,000 IU/mL of IL-2. In some embodiments, the first expansion culture media comprises about 6,000 IU/mL of IL-2. In an embodiment, the cell culture medium further comprises IL-2. In some embodiments, the cell culture medium comprises about 3000 IU/mL of IL-2. In an embodiment, the cell culture medium further comprises IL-2. In a preferred embodiment, the cell culture medium comprises about 3000 IU/mL of IL-2. In an embodiment, the cell culture medium comprises about 1000 IU/mL, about 1500 IU/mL, about 2000 IU/mL, about 2500 IU/mL, about 3000 IU/mL, about 3500 IU/mL, about 4000 IU/mL, about 4500 IU/mL, about 5000 IU/mL, about 5500 IU/mL, about 6000 IU/mL, about 6500 IU/mL, about 7000 IU/mL, about 7500 IU/mL, or about 8000 IU/mL of IL-2. In an embodiment, the cell culture medium

comprises between 1000 and 2000 IU/mL, between 2000 and 3000 IU/mL, between 3000 and 4000 IU/mL, between 4000 and 5000 IU/mL, between 5000 and 6000 IU/mL, between 6000 and 7000 IU/mL, between 7000 and 8000 IU/mL, or about 8000 IU/mL of IL-2.

[00308] In some embodiments, first expansion culture media comprises about 500 IU/mL of IL-15, about 400 IU/mL of IL-15, about 300 IU/mL of IL-15, about 200 IU/mL of IL-15, about 180 IU/mL of IL-15, about 160 IU/mL of IL-15, about 140 IU/mL of IL-15, about 120 IU/mL of IL-15, or about 100 IU/mL of IL-15. In some embodiments, the first expansion culture media comprises about 500 IU/mL of IL-15 to about 100 IU/mL of IL-15. In some embodiments, the first expansion culture media comprises about 400 IU/mL of IL-15 to about 100 IU/mL of IL-15. In some embodiments, the first expansion culture media comprises about 300 IU/mL of IL-15 to about 100 IU/mL of IL-15. In some embodiments, the first expansion culture media comprises about 200 IU/mL of IL-15. In some embodiments, the cell culture medium comprises about 180 IU/mL of IL-15. In an embodiment, the cell culture medium further comprises IL-15. In a preferred embodiment, the cell culture medium comprises about 180 IU/mL of IL-15.

[00309] In some embodiments, first expansion culture media comprises about 20 IU/mL of IL-21, about 15 IU/mL of IL-21, about 12 IU/mL of IL-21, about 10 IU/mL of IL-21, about 5 IU/mL of IL-21, about 4 IU/mL of IL-21, about 3 IU/mL of IL-21, about 2 IU/mL of IL-21, about 1 IU/mL of IL-21, or about 0.5 IU/mL of IL-21. In some embodiments, the first expansion culture media comprises about 20 IU/mL of IL-21 to about 0.5 IU/mL of IL-21. In some embodiments, the first expansion culture media comprises about 15 IU/mL of IL-21 to about 0.5 IU/mL of IL-21. In some embodiments, the first expansion culture media comprises about 12 IU/mL of IL-21 to about 0.5 IU/mL of IL-21. In some embodiments, the first expansion culture media comprises about 10 IU/mL of IL-21 to about 0.5 IU/mL of IL-21. In some embodiments, the first expansion culture media comprises about 5 IU/mL of IL-21 to about 1 IU/mL of IL-21. In some embodiments, the first expansion culture media comprises about 2 IU/mL of IL-21. In some embodiments, the cell culture medium comprises about 1 IU/mL of IL-21. In some embodiments, the cell culture medium comprises about 0.5 IU/mL of IL-21. In an embodiment, the cell culture medium further comprises IL-21. In a preferred embodiment, the cell culture medium comprises about 1 IU/mL of IL-21.

[00310] In some embodiments, the first expansion culture medium is referred to as "CM", an abbreviation for culture media. In some embodiments, it is referred to as CM1 (culture

medium 1). In some embodiments, CM consists of RPMI 1640 with GlutaMAX, supplemented with 10% human AB serum, 25 mM HEPES, and 10 mg/mL gentamicin. In embodiments where cultures are initiated in gas-permeable flasks with a 40 mL capacity and a 10cm<sup>2</sup> gas-permeable silicon bottom (for example, G-Rex10; Wilson Wolf Manufacturing, New Brighton, MN) (Fig. 1), each flask was loaded with 10–40x 10<sup>6</sup> viable tumor digest cells or 5–30 tumor fragments in 10–40mL of CM with IL-2. Both the G-Rex10 and 24-well plates were incubated in a humidified incubator at 37°C in 5% CO<sub>2</sub> and 5 days after culture initiation, half the media was removed and replaced with fresh CM and IL-2 and after day 5, half the media was changed every 2–3 days. In some embodiments, the CM is the CM1 described in the Examples, *see*, Example 5. In some embodiments, the first expansion occurs in an initial cell culture medium or a first cell culture medium. In some embodiments, the initial cell culture medium or the first cell culture medium comprises IL-2.

[00311] In some embodiments, the first expansion (including processes such as for example those described in Step B of Figure 27, which can include those sometimes referred to as the pre-REP) process is shortened to 3-14 days, as discussed in the examples and figures. In some embodiments, the first expansion (including processes such as for example those described in Step B of Figure 27, which can include those sometimes referred to as the pre-REP) is shortened to 7 to 14 days, as discussed in the Examples and shown in Figures 4 and 5, as well as including for example, an expansion as described in Step B of Figure 27. In some embodiments, the first expansion of Step B is shortened to 10-14 days, as discussed in the Examples and shown in Figures 4 and 5. In some embodiments, the first expansion is shortened to 11 days, as discussed in the Examples and shown in Figures 4 and 5, as well as including for example, an expansion as described in Step B of Figure 27.

[00312] In some embodiments, the first TIL expansion can proceed for 1 day, 2 days, 3 days, 4 days, 5 days, 6 days, 7 days, 8 days, 9 days, 10 days, 11 days, 12 days, 13 days, or 14 days. In some embodiments, the first TIL expansion can proceed for 1 day to 14 days. In some embodiments, the first TIL expansion can proceed for 2 days to 14 days. In some embodiments, the first TIL expansion can proceed for 3 days to 14 days. In some embodiments, the first TIL expansion can proceed for 4 days to 14 days. In some embodiments, the first TIL expansion can proceed for 5 days to 14 days. In some embodiments, the first TIL expansion can proceed for 6 days to 14 days. In some embodiments, the first TIL expansion can proceed for 7 days to 14 days. In some

embodiments, the first TIL expansion can proceed for 8 days to 14 days. In some  
embodiments, the first TIL expansion can proceed for 9 days to 14 days. In some  
embodiments, the first TIL expansion can proceed for 10 days to 14 days. In some  
embodiments, the first TIL expansion can proceed for 11 days to 14 days. In some  
5 embodiments, the first TIL expansion can proceed for 12 days to 14 days. In some  
embodiments, the first TIL expansion can proceed for 13 days to 14 days. In some  
embodiments, the first TIL expansion can proceed for 14 days. In some embodiments, the  
first TIL expansion can proceed for 1 day to 11 days. In some embodiments, the first TIL  
expansion can proceed for 2 days to 11 days. In some embodiments, the first TIL expansion  
10 can proceed for 3 days to 11 days. In some embodiments, the first TIL expansion can  
proceed for 4 days to 11 days. In some embodiments, the first TIL expansion can proceed for  
5 days to 11 days. In some embodiments, the first TIL expansion can proceed for 6 days to 11  
days. In some embodiments, the first TIL expansion can proceed for 7 days to 11 days. In  
some embodiments, the first TIL expansion can proceed for 8 days to 11 days. In some  
15 embodiments, the first TIL expansion can proceed for 9 days to 11 days. In some  
embodiments, the first TIL expansion can proceed for 10 days to 11 days. In some  
embodiments, the first TIL expansion can proceed for 11 days.

**[00313]** In some embodiments, a combination of IL-2, IL-7, IL-15, and/or IL-21 are  
employed as a combination during the first expansion. In some embodiments, IL-2, IL-7, IL-  
20 15, and/or IL-21 as well as any combinations thereof can be included during the first  
expansion, including for example during a Step B processes according to Figure 27, as well  
as described herein. In some embodiments, a combination of IL-2, IL-15, and IL-21 are  
employed as a combination during the first expansion. In some embodiments, IL-2, IL-15,  
and IL-21 as well as any combinations thereof can be included during Step B processes  
25 according to Figure 27 and as described herein.

**[00314]** In some embodiments, the first expansion (including processes referred to as the  
pre-REP; for example, Step B according to Figure 27) process is shortened to 3 to 14 days, as  
discussed in the examples and figures. In some embodiments, the first expansion of Step B is  
shortened to 7 to 14 days, as discussed in the Examples and shown in Figures 4 and 5. In  
30 some embodiments, the first expansion of Step B is shortened to 10 to 14 days, as discussed in  
the Examples and shown in Figures 4, 5, and 27. In some embodiments, the first expansion is  
shortened to 11 days, as discussed in the Examples and shown in Figures 4, 5, and 27.

[00315] In some embodiments, the first expansion, for example, Step B according to Figure 27, is performed in a closed system bioreactor. In some embodiments, a closed system is employed for the TIL expansion, as described herein. In some embodiments, a single bioreactor is employed. In some embodiments, the single bioreactor employed is for example a G-REX -10 or a G-REX -100. In some embodiments, the closed system bioreactor is a single bioreactor.

### C. STEP C: First Expansion to Second Expansion Transition

[00316] In some cases, the bulk TIL population obtained from the first expansion, including for example the TIL population obtained from for example, Step B as indicated in Figure 27, can be cryopreserved immediately, using the protocols discussed herein below.

Alternatively, the TIL population obtained from the first expansion, referred to as the second TIL population, can be subjected to a second expansion (which can include expansions sometimes referred to as REP) and then cryopreserved as discussed below. Similarly, in the case where genetically modified TILs will be used in therapy, the first TIL population (sometimes referred to as the bulk TIL population) or the second TIL population (which can in some embodiments include populations referred to as the REP TIL populations) can be subjected to genetic modifications for suitable treatments prior to expansion or after the first expansion and prior to the second expansion.

[00317] In some embodiments, the TILs obtained from the first expansion (for example, from Step B as indicated in Figure 27) are stored until phenotyped for selection. In some embodiments, the TILs obtained from the first expansion (for example, from Step B as indicated in Figure 27) are not stored and proceed directly to the second expansion. In some embodiments, the TILs obtained from the first expansion are not cryopreserved after the first expansion and prior to the second expansion. In some embodiments, the transition from the first expansion to the second expansion occurs at about 3 days, 4, days, 5 days, 6 days, 7 days, 8 days, 9 days, 10 days, 11 days, 12 days, 13 days, or 14 days from when fragmentation occurs. In some embodiments, the transition from the first expansion to the second expansion occurs at about 3 days to 14 days from when fragmentation occurs. In some embodiments, the transition from the first expansion to the second expansion occurs at about 4 days to 14 days from when fragmentation occurs. In some embodiments, the transition from the first expansion to the second expansion occurs at about 4 days to 10 days from when

fragmentation occurs. In some embodiments, the transition from the first expansion to the second expansion occurs at about 7 days to 14 days from when fragmentation occurs. In some embodiments, the transition from the first expansion to the second expansion occurs at about 14 days from when fragmentation occurs.

- 5 **[00318]** In some embodiments, the transition from the first expansion to the second expansion occurs at 1 day, 2 days, 3 days, 4 days, 5 days, 6 days, 7 days, 8 days, 9 days, 10 days, 11 days, 12 days, 13 days, or 14 days from when fragmentation occurs. In some embodiments, the transition from the first expansion to the second expansion occurs 1 day to 14 days from when fragmentation occurs. In some embodiments, the first TIL expansion can
- 10 proceed for 2 days to 14 days. In some embodiments, the transition from the first expansion to the second expansion occurs 3 days to 14 days from when fragmentation occurs. In some embodiments, the transition from the first expansion to the second expansion occurs 4 days to 14 days from when fragmentation occurs. In some embodiments, the transition from the first expansion to the second expansion occurs 5 days to 14 days from when fragmentation occurs.
- 15 In some embodiments, the transition from the first expansion to the second expansion occurs 6 days to 14 days from when fragmentation occurs. In some embodiments, the transition from the first expansion to the second expansion occurs 7 days to 14 days from when fragmentation occurs. In some embodiments, the transition from the first expansion to the second expansion occurs 8 days to 14 days from when fragmentation occurs. In some
- 20 embodiments, the transition from the first expansion to the second expansion occurs 9 days to 14 days from when fragmentation occurs. In some embodiments, the transition from the first expansion to the second expansion occurs 10 days to 14 days from when fragmentation occurs. In some embodiments, the transition from the first expansion to the second expansion occurs 11 days to 14 days from when fragmentation occurs. In some embodiments, the
- 25 transition from the first expansion to the second expansion occurs 12 days to 14 days from when fragmentation occurs. In some embodiments, the transition from the first expansion to the second expansion occurs 13 days to 14 days from when fragmentation occurs. In some embodiments, the transition from the first expansion to the second expansion occurs 14 days from when fragmentation occurs. In some embodiments, the transition from the first
- 30 expansion to the second expansion occurs 1 day to 11 days from when fragmentation occurs. In some embodiments, the transition from the first expansion to the second expansion occurs 2 days to 11 days from when fragmentation occurs. In some embodiments, the transition

from the first expansion to the second expansion occurs 3 days to 11 days from when fragmentation occurs. In some embodiments, the transition from the first expansion to the second expansion occurs 4 days to 11 days from when fragmentation occurs. In some embodiments, the transition from the first expansion to the second expansion occurs 5 days to 11 days from when fragmentation occurs. In some embodiments, the transition from the first expansion to the second expansion occurs 6 days to 11 days from when fragmentation occurs. In some embodiments, the transition from the first expansion to the second expansion occurs 7 days to 11 days from when fragmentation occurs. In some embodiments, the transition from the first expansion to the second expansion occurs 8 days to 11 days from when fragmentation occurs. In some embodiments, the transition from the first expansion to the second expansion occurs 9 days to 11 days from when fragmentation occurs. In some embodiments, the transition from the first expansion to the second expansion occurs 10 days to 11 days from when fragmentation occurs. In some embodiments, the transition from the first expansion to the second expansion occurs 11 days from when fragmentation occurs.

[00319] In some embodiments, the TILs are not stored after the first expansion and prior to the second expansion, and the TILs proceed directly to the second expansion (for example, in some embodiments, there is no storage during the transition from Step B to Step D as shown in Figure 27). In some embodiments, the transition occurs in closed system, as described herein. In some embodiments, the TILs from the first expansion, the second population of TILs, proceeds directly into the second expansion with no transition period.

[00320] In some embodiments, the transition from the first expansion to the second expansion, for example, Step C according to Figure 27, is performed in a closed system bioreactor. In some embodiments, a closed system is employed for the TIL expansion, as described herein. In some embodiments, a single bioreactor is employed. In some embodiments, the single bioreactor employed is for example a G-REX -10 or a G-REX -100. In some embodiments, the closed system bioreactor is a single bioreactor.

#### **D. STEP D: Second Expansion**

[00321] In some embodiments, the TIL cell population is expanded in number after harvest and initial bulk processing for example, after Step A and Step B, and the transition referred to as Step C, as indicated in Figure 27). This further expansion is referred to herein as the second expansion, which can include expansion processes generally referred to in the art as a

rapid expansion process (REP; as well as processes as indicated in Step D of Figure 27). The second expansion is generally accomplished using a culture media comprising a number of components, including feeder cells, a cytokine source, and an anti-CD3 antibody, in a gas-permeable container.

5 [00322] In some embodiments, the second expansion or second TIL expansion (which can include expansions sometimes referred to as REP; as well as processes as indicated in Step D of Figure 27) of TIL can be performed using any TIL flasks or containers known by those of skill in the art. In some embodiments, the second TIL expansion can proceed for 7 days, 8 days, 9 days, 10 days, 11 days, 12 days, 13 days, or 14 days. In some embodiments, the  
10 second TIL expansion can proceed for about 7 days to about 14 days. In some embodiments, the second TIL expansion can proceed for about 8 days to about 14 days. In some embodiments, the second TIL expansion can proceed for about 9 days to about 14 days. In some embodiments, the second TIL expansion can proceed for about 10 days to about 14 days. In some embodiments, the second TIL expansion can proceed for about 11 days to  
15 about 14 days. In some embodiments, the second TIL expansion can proceed for about 12 days to about 14 days. In some embodiments, the second TIL expansion can proceed for about 13 days to about 14 days. In some embodiments, the second TIL expansion can proceed for about 14 days.

[00323] In an embodiment, the second expansion can be performed in a gas permeable  
20 container using the methods of the present disclosure (including for example, expansions referred to as REP; as well as processes as indicated in Step D of Figure 27). For example, TILs can be rapidly expanded using non-specific T-cell receptor stimulation in the presence of interleukin-2 (IL-2) or interleukin-15 (IL-15). The non-specific T-cell receptor stimulus can include, for example, an anti-CD3 antibody, such as about 30 ng/ml of OKT3, a mouse  
25 monoclonal anti-CD3 antibody (commercially available from Ortho-McNeil, Raritan, NJ or Miltenyi Biotech, Auburn, CA) or UHCT-1 (commercially available from BioLegend, San Diego, CA, USA). TILs can be expanded to induce further stimulation of the TILs *in vitro* by including one or more antigens during the second expansion, including antigenic portions thereof, such as epitope(s), of the cancer, which can be optionally expressed from a vector,  
30 such as a human leukocyte antigen A2 (HLA-A2) binding peptide, *e.g.*, 0.3  $\mu$ M MART-1 :26-35 (27 L) or gpl 00:209-217 (210M), optionally in the presence of a T-cell growth factor, such as 300 IU/mL IL-2 or IL-15. Other suitable antigens may include, *e.g.*, NY-ESO-1,

TRP-1, TRP-2, tyrosinase cancer antigen, MAGE-A3, SSX-2, and VEGFR2, or antigenic portions thereof. TIL may also be rapidly expanded by re-stimulation with the same antigen(s) of the cancer pulsed onto HLA-A2-expressing antigen-presenting cells.

Alternatively, the TILs can be further re-stimulated with, *e.g.*, example, irradiated, autologous lymphocytes or with irradiated HLA-A2+ allogeneic lymphocytes and IL-2. In some embodiments, the re-stimulation occurs as part of the second expansion. In some embodiments, the second expansion occurs in the presence of irradiated, autologous lymphocytes or with irradiated HLA-A2+ allogeneic lymphocytes and IL-2.

[00324] In an embodiment, the cell culture medium further comprises IL-2. In some embodiments, the cell culture medium comprises about 3000 IU/mL of IL-2. In an embodiment, the cell culture medium comprises about 1000 IU/mL, about 1500 IU/mL, about 2000 IU/mL, about 2500 IU/mL, about 3000 IU/mL, about 3500 IU/mL, about 4000 IU/mL, about 4500 IU/mL, about 5000 IU/mL, about 5500 IU/mL, about 6000 IU/mL, about 6500 IU/mL, about 7000 IU/mL, about 7500 IU/mL, or about 8000 IU/mL of IL-2. In an embodiment, the cell culture medium comprises between 1000 and 2000 IU/mL, between 2000 and 3000 IU/mL, between 3000 and 4000 IU/mL, between 4000 and 5000 IU/mL, between 5000 and 6000 IU/mL, between 6000 and 7000 IU/mL, between 7000 and 8000 IU/mL, or between 8000 IU/mL of IL-2.

[00325] In an embodiment, the cell culture medium comprises OKT3 antibody. In some embodiments, the cell culture medium comprises about 30 ng/mL of OKT3 antibody. In an embodiment, the cell culture medium comprises about 0.1 ng/mL, about 0.5 ng/mL, about 1 ng/mL, about 2.5 ng/mL, about 5 ng/mL, about 7.5 ng/mL, about 10 ng/mL, about 15 ng/mL, about 20 ng/mL, about 25 ng/mL, about 30 ng/mL, about 35 ng/mL, about 40 ng/mL, about 50 ng/mL, about 60 ng/mL, about 70 ng/mL, about 80 ng/mL, about 90 ng/mL, about 100 ng/mL, about 200 ng/mL, about 500 ng/mL, and about 1  $\mu$ g/mL of OKT3 antibody. In an embodiment, the cell culture medium comprises between 0.1 ng/mL and 1 ng/mL, between 1 ng/mL and 5 ng/mL, between 5 ng/mL and 10 ng/mL, between 10 ng/mL and 20 ng/mL, between 20 ng/mL and 30 ng/mL, between 30 ng/mL and 40 ng/mL, between 40 ng/mL and 50 ng/mL, and between 50 ng/mL and 100 ng/mL of OKT3 antibody.

[00326] In some embodiments, a combination of IL-2, IL-7, IL-15, and/or IL-21 are employed as a combination during the second expansion. In some embodiments, IL-2, IL-7, IL-15, and/or IL-21 as well as any combinations thereof can be included during the second

expansion, including for example during a Step D processes according to Figure 27, as well as described herein. In some embodiments, a combination of IL-2, IL-15, and IL-21 are employed as a combination during the second expansion. In some embodiments, IL-2, IL-15, and IL-21 as well as any combinations thereof can be included during Step D processes  
5 according to Figure 27 and as described herein.

**[00327]** In some embodiments, the second expansion can be conducted in a supplemented cell culture medium comprising IL-2, OKT-3, and antigen-presenting feeder cells. In some embodiments, the second expansion occurs in a supplemented cell culture medium. In some  
10 embodiments, the supplemented cell culture medium comprises IL-2, OKT-3, and antigen-presenting feeder cells. In some embodiments, the second cell culture medium comprises IL-2, OKT-3, and antigen-presenting cells (APCs; also referred to as antigen-presenting feeder cells). In some embodiments, the second expansion occurs in a cell culture medium comprising IL-2, OKT-3, and antigen-presenting feeder cells (*i.e.*, antigen presenting cells).

**[00328]** In some embodiments, the second expansion culture media comprises about 500  
15 IU/mL of IL-15, about 400 IU/mL of IL-15, about 300 IU/mL of IL-15, about 200 IU/mL of IL-15, about 180 IU/mL of IL-15, about 160 IU/mL of IL-15, about 140 IU/mL of IL-15, about 120 IU/mL of IL-15, or about 100 IU/mL of IL-15. In some embodiments, the second expansion culture media comprises about 500 IU/mL of IL-15 to about 100 IU/mL of IL-15. In some embodiments, the second expansion culture media comprises about 400 IU/mL of  
20 IL-15 to about 100 IU/mL of IL-15. In some embodiments, the second expansion culture media comprises about 300 IU/mL of IL-15 to about 100 IU/mL of IL-15. In some embodiments, the second expansion culture media comprises about 200 IU/mL of IL-15. In some embodiments, the cell culture medium comprises about 180 IU/mL of IL-15. In an embodiment, the cell culture medium further comprises IL-15. In a preferred embodiment,  
25 the cell culture medium comprises about 180 IU/mL of IL-15.

**[00329]** In some embodiments, the second expansion culture media comprises about 20  
IU/mL of IL-21, about 15 IU/mL of IL-21, about 12 IU/mL of IL-21, about 10 IU/mL of IL-21, about 5 IU/mL of IL-21, about 4 IU/mL of IL-21, about 3 IU/mL of IL-21, about 2 IU/mL of IL-21, about 1 IU/mL of IL-21, or about 0.5 IU/mL of IL-21. In some embodiments, the  
30 second expansion culture media comprises about 20 IU/mL of IL-21 to about 0.5 IU/mL of IL-21. In some embodiments, the second expansion culture media comprises about 15 IU/mL of IL-21 to about 0.5 IU/mL of IL-21. In some embodiments, the second expansion culture

- media comprises about 12 IU/mL of IL-21 to about 0.5 IU/mL of IL-21. In some embodiments, the second expansion culture media comprises about 10 IU/mL of IL-21 to about 0.5 IU/mL of IL-21. In some embodiments, the second expansion culture media comprises about 5 IU/mL of IL-21 to about 1 IU/mL of IL-21. In some embodiments, the second expansion culture media comprises about 2 IU/mL of IL-21. In some embodiments, the cell culture medium comprises about 1 IU/mL of IL-21. In some embodiments, the cell culture medium comprises about 0.5 IU/mL of IL-21. In an embodiment, the cell culture medium further comprises IL-21. In a preferred embodiment, the cell culture medium comprises about 1 IU/mL of IL-21.
- 10 **[00330]** In some embodiments the antigen-presenting feeder cells (APCs) are PBMCs. In an embodiment, the ratio of TILs to PBMCs and/or antigen-presenting cells in the rapid expansion and/or the second expansion is about 1 to 25, about 1 to 50, about 1 to 100, about 1 to 125, about 1 to 150, about 1 to 175, about 1 to 200, about 1 to 225, about 1 to 250, about 1 to 275, about 1 to 300, about 1 to 325, about 1 to 350, about 1 to 375, about 1 to 400, or about 15 1 to 500. In an embodiment, the ratio of TILs to PBMCs in the rapid expansion and/or the second expansion is between 1 to 50 and 1 to 300. In an embodiment, the ratio of TILs to PBMCs in the rapid expansion and/or the second expansion is between 1 to 100 and 1 to 200.
- [00331]** In an embodiment, REP and/or the second expansion is performed in flasks with the bulk TILs being mixed with a 100- or 200-fold excess of inactivated feeder cells, 30 mg/mL OKT3 anti-CD3 antibody and 3000 IU/mL IL-2 in 150 ml media. Media replacement is done (generally 2/3 media replacement via respiration with fresh media) until the cells are transferred to an alternative growth chamber. Alternative growth chambers include G-REX flasks and gas permeable containers as more fully discussed below.
- 20 **[00332]** In some embodiments, the second expansion (which can include processes referred to as the REP process) is shortened to 7-14 days, as discussed in the examples and figures. In some embodiments, the second expansion is shortened to 11 days.
- [00333]** In an embodiment, REP and/or the second expansion may be performed using T-175 flasks and gas permeable bags as previously described (Tran, *et al.*, *J. Immunother.* **2008**, 31, 742-51; Dudley, *et al.*, *J. Immunother.* **2003**, 26, 332-42) or gas permeable cultureware (G-Rex flasks). In some embodiments, the second expansion (including expansions referred to as rapid expansions) is performed in T-175 flasks, and about  $1 \times 10^6$  TILs suspended in 30 150 mL of media may be added to each T-175 flask. The TILs may be cultured in a 1 to 1

mixture of CM and AIM-V medium, supplemented with 3000 IU per mL of IL-2 and 30 ng per ml of anti-CD3. The T-175 flasks may be incubated at 37° C in 5% CO<sub>2</sub>. Half the media may be exchanged on day 5 using 50/50 medium with 3000 IU per mL of IL-2. In some embodiments, on day 7 cells from two T-175 flasks may be combined in a 3 L bag and 300 mL of AIM V with 5% human AB serum and 3000 IU per mL of IL-2 was added to the 300 ml of TIL suspension. The number of cells in each bag was counted every day or two and fresh media was added to keep the cell count between 0.5 and 2.0 x 10<sup>6</sup> cells/mL.

**[00334]** In an embodiment, the second expansion (which can include expansions referred to as REP, as well as those referred to in Step D of Figure 27) may be performed in 500 mL capacity gas permeable flasks with 100 cm gas-permeable silicon bottoms (G-Rex 100, commercially available from Wilson Wolf Manufacturing Corporation, New Brighton, MN, USA), 5 × 10<sup>6</sup> or 10 × 10<sup>6</sup> TIL may be cultured with PBMCs in 400 mL of 50/50 medium, supplemented with 5% human AB serum, 3000 IU per mL of IL-2 and 30 ng per ml of anti-CD3 (OKT3). The G-Rex 100 flasks may be incubated at 37°C in 5% CO<sub>2</sub>. On day 5, 250 mL of supernatant may be removed and placed into centrifuge bottles and centrifuged at 1500 rpm (491 × g) for 10 minutes. The TIL pellets may be re-suspended with 150 mL of fresh medium with 5% human AB serum, 3000 IU per mL of IL-2, and added back to the original G-Rex 100 flasks. When TIL are expanded serially in G-Rex 100 flasks, on day 7 the TIL in each G-Rex 100 may be suspended in the 300 mL of media present in each flask and the cell suspension may be divided into 3 100 mL aliquots that may be used to seed 3 G-Rex 100 flasks. Then 150 mL of AIM-V with 5% human AB serum and 3000 IU per mL of IL-2 may be added to each flask. The G-Rex 100 flasks may be incubated at 37° C in 5% CO<sub>2</sub> and after 4 days 150 mL of AIM-V with 3000 IU per mL of IL-2 may be added to each G-REX 100 flask. The cells may be harvested on day 14 of culture.

**[00335]** In an embodiment, the second expansion (including expansions referred to as REP) is performed in flasks with the bulk TILs being mixed with a 100- or 200-fold excess of inactivated feeder cells, 30 mg/mL OKT3 anti-CD3 antibody and 3000 IU/mL IL-2 in 150 ml media. In some embodiments, media replacement is done until the cells are transferred to an alternative growth chamber. In some embodiments, 2/3 of the media is replaced by respiration with fresh media. In some embodiments, alternative growth chambers include G-REX flasks and gas permeable containers as more fully discussed below.

[00336] In an embodiment, the second expansion (including expansions referred to as REP) is performed and further comprises a step wherein TILs are selected for superior tumor reactivity. Any selection method known in the art may be used. For example, the methods described in U.S. Patent Application Publication No. 2016/0010058 A1, the disclosures of which are incorporated herein by reference, may be used for selection of TILs for superior tumor reactivity.

[00337] Optionally, a cell viability assay can be performed after the second expansion (including expansions referred to as the REP expansion), using standard assays known in the art. For example, a trypan blue exclusion assay can be done on a sample of the bulk TILs, which selectively labels dead cells and allows a viability assessment. In some embodiments, TIL samples can be counted and viability determined using a Cellometer K2 automated cell counter (Nexcelom Bioscience, Lawrence, MA). In some embodiments, viability is determined according to the Cellometer K2 Image Cytometer Automatic Cell Counter protocol described, for example, in Example 15.

[00338] In some embodiments, the second expansion (including expansions referred to as REP) of TIL can be performed using T-175 flasks and gas-permeable bags as previously described (Tran KQ, Zhou J, Durflinger KH, et al., 2008, *J Immunother.*, 31:742–751, and Dudley ME, Wunderlich JR, Shelton TE, et al. 2003, *J Immunother.*, 26:332–342) or gas-permeable G-Rex flasks. In some embodiments, the second expansion is performed using flasks. In some embodiments, the second expansion is performed using gas-permeable G-Rex flasks. In some embodiments, the second expansion is performed in T-175 flasks, and about  $1 \times 10^6$  TIL are suspended in about 150 mL of media and this is added to each T-175 flask. The TIL are cultured with irradiated (50 Gy) allogeneic PBMC as “feeder” cells at a ratio of 1 to 100 and the cells were cultured in a 1 to 1 mixture of CM and AIM-V medium (50/50 medium), supplemented with 3000 IU/mL of IL-2 and 30 ng/mL of anti-CD3. The T-175 flasks are incubated at 37°C in 5% CO<sub>2</sub>. In some embodiments, half the media is changed on day 5 using 50/50 medium with 3000 IU/mL of IL-2. In some embodiments, on day 7, cells from 2 T-175 flasks are combined in a 3 L bag and 300 mL of AIM-V with 5% human AB serum and 3000 IU/mL of IL-2 is added to the 300 mL of TIL suspension. The number of cells in each bag can be counted every day or two and fresh media can be added to keep the cell count between about 0.5 and about  $2.0 \times 10^6$  cells/mL.

[00339] In some embodiments, the second expansion (including expansions referred to as REP) are performed in 500 mL capacity flasks with 100 cm<sup>2</sup> gas-permeable silicon bottoms (G-Rex 100, Wilson Wolf) (Fig. 1), about 5x10<sup>6</sup> or 10x10<sup>6</sup> TIL are cultured with irradiated allogeneic PBMC at a ratio of 1 to 100 in 400 mL of 50/50 medium, supplemented with 3000 IU/mL of IL-2 and 30 ng/ mL of anti-CD3. The G-Rex 100 flasks are incubated at 37°C in 5% CO<sub>2</sub>. In some embodiments, on day 5, 250mL of supernatant is removed and placed into centrifuge bottles and centrifuged at 1500 rpm (491g) for 10 minutes. The TIL pellets can then be resuspended with 150 mL of fresh 50/50 medium with 3000 IU/ mL of IL-2 and added back to the original G-Rex 100 flasks. In embodiments where TILs are expanded serially in G-Rex 100 flasks, on day 7 the TIL in each G-Rex 100 are suspended in the 300 mL of media present in each flask and the cell suspension was divided into three 100 mL aliquots that are used to seed 3 G-Rex 100 flasks. Then 150 mL of AIM-V with 5% human AB serum and 3000 IU/mL of IL-2 is added to each flask. The G-Rex 100 flasks are incubated at 37°C in 5% CO<sub>2</sub> and after 4 days 150 mL of AIM-V with 3000 IU/mL of IL-2 is added to each G-Rex 100 flask. The cells are harvested on day 14 of culture.

[00340] The diverse antigen receptors of T and B lymphocytes are produced by somatic recombination of a limited, but large number of gene segments. These gene segments: V (variable), D (diversity), J (joining), and C (constant), determine the binding specificity and downstream applications of immunoglobulins and T-cell receptors (TCRs). The present invention provides a method for generating TILs which exhibit and increase the T-cell repertoire diversity. In some embodiments, the TILs obtained by the present method exhibit an increase in the T-cell repertoire diversity. In some embodiments, the TILs obtained in the second expansion exhibit an increase in the T-cell repertoire diversity. In some embodiments, the increase in diversity is an increase in the immunoglobulin diversity and/or the T-cell receptor diversity. In some embodiments, the diversity is in the immunoglobulin is in the immunoglobulin heavy chain. In some embodiments, the diversity is in the immunoglobulin is in the immunoglobulin light chain. In some embodiments, the diversity is in the T-cell receptor. In some embodiments, the diversity is in one of the T-cell receptors selected from the group consisting of alpha, beta, gamma, and delta receptors. In some embodiments, there is an increase in the expression of T-cell receptor (TCR) alpha and/or beta. In some embodiments, there is an increase in the expression of T-cell receptor (TCR) alpha. In some embodiments, there is an increase in the expression of T-cell receptor

(TCR) beta. In some embodiments, there is an increase in the expression of TCRab (*i.e.*, TCR $\alpha/\beta$ ).

5 [00341] In some embodiments, the second expansion culture medium (*e.g.*, sometimes referred to as CM2 or the second cell culture medium), comprises IL-2, OKT-3, as well as the antigen-presenting feeder cells (APCs), as discussed in more detail below.

[00342] In some embodiments, the second expansion, for example, Step D according to Figure 27, is performed in a closed system bioreactor. In some embodiments, a closed system is employed for the TIL expansion, as described herein. In some embodiments, a  
10 single bioreactor is employed. In some embodiments, the single bioreactor employed is for example a G-REX -10 or a G-REX -100. In some embodiments, the closed system bioreactor is a single bioreactor.

#### 1. Feeder Cells and Antigen Presenting Cells

[00343] In an embodiment, the second expansion procedures described herein (for example including expansion such as those described in Step D from Figure 27, as well as those  
15 referred to as REP) require an excess of feeder cells during REP TIL expansion and/or during the second expansion. In many embodiments, the feeder cells are peripheral blood mononuclear cells (PBMCs) obtained from standard whole blood units from healthy blood donors. The PBMCs are obtained using standard methods such as Ficoll-Paque gradient  
20 separation.

[00344] In general, the allogenic PBMCs are inactivated, either via irradiation or heat treatment, and used in the REP procedures, as described in the examples, in particular example 14, which provides an exemplary protocol for evaluating the replication  
incompetence of irradiate allogeneic PBMCs.

25 [00345] In some embodiments, PBMCs are considered replication incompetent and accepted for use in the TIL expansion procedures described herein if the total number of viable cells on day 14 is less than the initial viable cell number put into culture on day 0 of the REP and/or day 0 of the second expansion (*i.e.*, the start day of the second expansion). See, for example, Example 14.

30 [00346] In some embodiments, PBMCs are considered replication incompetent and accepted for use in the TIL expansion procedures described herein if the total number of

viable cells, cultured in the presence of OKT3 and IL-2, on day 7 and day 14 has not increased from the initial viable cell number put into culture on day 0 of the REP and/or day 0 of the second expansion (*i.e.*, the start day of the second expansion). In some embodiments, the PBMCs are cultured in the presence of 30 ng/ml OKT3 antibody and 3000 IU/ml IL-2. See, for example, Example 13.

**[00347]** In some embodiments, PBMCs are considered replication incompetent and accepted for use in the TIL expansion procedures described herein if the total number of viable cells, cultured in the presence of OKT3 and IL-2, on day 7 and day 14 has not increased from the initial viable cell number put into culture on day 0 of the REP and/or day 0 of the second expansion (*i.e.*, the start day of the second expansion). In some embodiments, the PBMCs are cultured in the presence of 5-60 ng/ml OKT3 antibody and 1000-6000 IU/ml IL-2. In some embodiments, the PBMCs are cultured in the presence of 10-50 ng/ml OKT3 antibody and 2000-5000 IU/ml IL-2. In some embodiments, the PBMCs are cultured in the presence of 20-40 ng/ml OKT3 antibody and 2000-4000 IU/ml IL-2. In some embodiments, the PBMCs are cultured in the presence of 25-35 ng/ml OKT3 antibody and 2500-3500 IU/ml IL-2.

**[00348]** In some embodiments, the antigen-presenting feeder cells are PBMCs. In some embodiments, the antigen-presenting feeder cells are artificial antigen-presenting feeder cells. In an embodiment, the ratio of TILs to antigen-presenting feeder cells in the second expansion is about 1 to 25, about 1 to 50, about 1 to 100, about 1 to 125, about 1 to 150, about 1 to 175, about 1 to 200, about 1 to 225, about 1 to 250, about 1 to 275, about 1 to 300, about 1 to 325, about 1 to 350, about 1 to 375, about 1 to 400, or about 1 to 500. In an embodiment, the ratio of TILs to antigen-presenting feeder cells in the second expansion is between 1 to 50 and 1 to 300. In an embodiment, the ratio of TILs to antigen-presenting feeder cells in the second expansion is between 1 to 100 and 1 to 200.

**[00349]** In an embodiment, the second expansion procedures described herein require a ratio of about  $2.5 \times 10^9$  feeder cells to about  $100 \times 10^6$  TILs. In another embodiment, the second expansion procedures described herein require a ratio of about  $2.5 \times 10^9$  feeder cells to about  $50 \times 10^6$  TILs. In yet another embodiment, the second expansion procedures described herein require about  $2.5 \times 10^9$  feeder cells to about  $25 \times 10^6$  TILs.

**[00350]** In an embodiment, the second expansion procedures described herein require an excess of feeder cells during the second expansion. In many embodiments, the feeder cells

are peripheral blood mononuclear cells (PBMCs) obtained from standard whole blood units from healthy blood donors. The PBMCs are obtained using standard methods such as Ficoll-Paque gradient separation. In an embodiment, artificial antigen-presenting (aAPC) cells are used in place of PBMCs.

5 [00351] In general, the allogenic PBMCs are inactivated, either via irradiation or heat treatment, and used in the TIL expansion procedures described herein, including the exemplary procedures described in Figures 4, 5, and 27.

[00352] In an embodiment, artificial antigen presenting cells are used in the second expansion as a replacement for, or in combination with, PBMCs.

10 2. Cytokines

[00353] The expansion methods described herein generally use culture media with high doses of a cytokine, in particular IL-2, as is known in the art.

[00354] Alternatively, using combinations of cytokines for the rapid expansion and or second expansion of TILS is additionally possible, with combinations of two or more of IL-2, IL-15 and IL-21 as is generally outlined in International Publication No. WO 2015/189356 and W International Publication No. WO 2015/189357, hereby expressly incorporated by reference in their entirety. Thus, possible combinations include IL-2 and IL-15, IL-2 and IL-21, IL-15 and IL-21 and IL-2, IL-15 and IL-21, with the latter finding particular use in many embodiments. The use of combinations of cytokines specifically favors the generation of lymphocytes, and in particular T-cells as described therein.

20

3. Anti-CD3 Antibodies

[00355] In some embodiments, the culture media used in expansion methods described herein (including those referred to as REP, see for example, Figure 27) also includes an anti-CD3 antibody. An anti-CD3 antibody in combination with IL-2 induces T cell activation and cell division in the TIL population. This effect can be seen with full length antibodies as well as Fab and F(ab')<sub>2</sub> fragments, with the former being generally preferred; see, *e.g.*, Tsoukas *et al.*, *J. Immunol.* **1985**, *135*, 1719, hereby incorporated by reference in its entirety.

25

[00356] As will be appreciated by those in the art, there are a number of suitable anti-human CD3 antibodies that find use in the invention, including anti-human CD3 polyclonal and monoclonal antibodies from various mammals, including, but not limited to, murine, human, primate, rat, and canine antibodies. In particular embodiments, the OKT3 anti-CD3 antibody

30

is used (commercially available from Ortho-McNeil, Raritan, NJ or Miltenyi Biotech, Auburn, CA).

**E. STEP E: Harvest TILS**

5 [00357] After the second expansion step, cells can be harvested. In some embodiments the TILs are harvested after one, two, three, four or more expansion steps, for example as provided in Figure 27. In some embodiments the TILs are harvested after two expansion steps, for example as provided in Figure 27.

[00358] TILs can be harvested in any appropriate and sterile manner, including for example  
10 by centrifugation. Methods for TIL harvesting are well known in the art and any such know methods can be employed with the present process. In some embodiments, TILS are harvest using an automated system.

[00359] Cell harvesters and/or cell processing systems are commercially available from a variety of sources, including, for example, Fresenius Kabi, Tomtec Life Science,  
15 Perkin Elmer, and Inotech Biosystems International, Inc. Any cell based harvester can be employed with the present methods. In some embodiments, the cell harvester and/or cell processing systems is a membrane-based cell harvester. In some embodiments, cell harvesting is via a cell processing system, such as the LOVO system (manufactured by Fresenius Kabi). The term “LOVO cell processing system” also refers to any instrument or  
20 device manufactured by any vendor that can pump a solution comprising cells through a membrane or filter such as a spinning membrane or spinning filter in a sterile and/or closed system environment, allowing for continuous flow and cell processing to remove supernatant or cell culture media without pelletization. In some embodiments, the cell harvester and/or cell processing system can perform cell separation, washing, fluid-exchange, concentration,  
25 and/or other cell processing steps in a closed, sterile system.

[00360] In some embodiments, the harvest, for example, Step E according to Figure 27, is performed from a closed system bioreactor. In some embodiments, a closed system is employed for the TIL expansion, as described herein. In some embodiments, a single bioreactor is employed. In some embodiments, the single bioreactor employed is for example  
30 a G-REX -10 or a G-REX -100. In some embodiments, the closed system bioreactor is a single bioreactor.

#### F. STEP F: Final Formulation/ Transfer to Infusion Bag

[00361] After Steps A through E as provided in an exemplary order in Figure 27 and as outlined in detailed above and herein are complete, cells are transferred to a container for use in administration to a patient. In some embodiments, once a therapeutically sufficient number of TILs are obtained using the expansion methods described above, they are transferred to a container for use in administration to a patient.

[00362] In an embodiment, TILs expanded using APCs of the present disclosure are administered to a patient as a pharmaceutical composition. In an embodiment, the pharmaceutical composition is a suspension of TILs in a sterile buffer. TILs expanded using PBMCs of the present disclosure may be administered by any suitable route as known in the art. In some embodiments, the T-cells are administered as a single intra-arterial or intravenous infusion, which preferably lasts approximately 30 to 60 minutes. Other suitable routes of administration include intraperitoneal, intrathecal, and intralymphatic.

##### 1. Pharmaceutical Compositions, Dosages, and Dosing Regimens

[00363] In an embodiment, TILs expanded using the methods of the present disclosure are administered to a patient as a pharmaceutical composition. In an embodiment, the pharmaceutical composition is a suspension of TILs in a sterile buffer. TILs expanded using PBMCs of the present disclosure may be administered by any suitable route as known in the art. In some embodiments, the T-cells are administered as a single intra-arterial or intravenous infusion, which preferably lasts approximately 30 to 60 minutes. Other suitable routes of administration include intraperitoneal, intrathecal, and intralymphatic administration.

[00364] Any suitable dose of TILs can be administered. In some embodiments, from about  $2.3 \times 10^{10}$  to about  $13.7 \times 10^{10}$  TILs are administered, with an average of around  $7.8 \times 10^{10}$  TILs, particularly if the cancer is melanoma. In an embodiment, about  $1.2 \times 10^{10}$  to about  $4.3 \times 10^{10}$  of TILs are administered. In some embodiments, about  $3 \times 10^{10}$  to about  $12 \times 10^{10}$  TILs are administered. In some embodiments, about  $4 \times 10^{10}$  to about  $10 \times 10^{10}$  TILs are administered. In some embodiments, about  $5 \times 10^{10}$  to about  $8 \times 10^{10}$  TILs are administered. In some embodiments, about  $6 \times 10^{10}$  to about  $8 \times 10^{10}$  TILs are administered. In some embodiments, about  $7 \times 10^{10}$  to about  $8 \times 10^{10}$  TILs are administered. In some embodiments, the

therapeutically effective dosage is about  $2.3 \times 10^{10}$  to about  $13.7 \times 10^{10}$ . In some embodiments, the therapeutically effective dosage is about  $7.8 \times 10^{10}$  TILs, particularly of the cancer is melanoma. In some embodiments, the therapeutically effective dosage is about  $1.2 \times 10^{10}$  to about  $4.3 \times 10^{10}$  of TILs. In some embodiments, the therapeutically effective dosage is about  $3 \times 10^{10}$  to about  $12 \times 10^{10}$  TILs. In some embodiments, the therapeutically effective dosage is about  $4 \times 10^{10}$  to about  $10 \times 10^{10}$  TILs. In some embodiments, the therapeutically effective dosage is about  $5 \times 10^{10}$  to about  $8 \times 10^{10}$  TILs. In some embodiments, the therapeutically effective dosage is about  $6 \times 10^{10}$  to about  $8 \times 10^{10}$  TILs. In some embodiments, the therapeutically effective dosage is about  $7 \times 10^{10}$  to about  $8 \times 10^{10}$  TILs.

10 **[00365]** In some embodiments, the number of the TILs provided in the pharmaceutical compositions of the invention is about  $1 \times 10^6$ ,  $2 \times 10^6$ ,  $3 \times 10^6$ ,  $4 \times 10^6$ ,  $5 \times 10^6$ ,  $6 \times 10^6$ ,  $7 \times 10^6$ ,  $8 \times 10^6$ ,  $9 \times 10^6$ ,  $1 \times 10^7$ ,  $2 \times 10^7$ ,  $3 \times 10^7$ ,  $4 \times 10^7$ ,  $5 \times 10^7$ ,  $6 \times 10^7$ ,  $7 \times 10^7$ ,  $8 \times 10^7$ ,  $9 \times 10^7$ ,  $1 \times 10^8$ ,  $2 \times 10^8$ ,  $3 \times 10^8$ ,  $4 \times 10^8$ ,  $5 \times 10^8$ ,  $6 \times 10^8$ ,  $7 \times 10^8$ ,  $8 \times 10^8$ ,  $9 \times 10^8$ ,  $1 \times 10^9$ ,  $2 \times 10^9$ ,  $3 \times 10^9$ ,  $4 \times 10^9$ ,  $5 \times 10^9$ ,  $6 \times 10^9$ ,  $7 \times 10^9$ ,  $8 \times 10^9$ ,  $9 \times 10^9$ ,  $1 \times 10^{10}$ ,  $2 \times 10^{10}$ ,  $3 \times 10^{10}$ ,  $4 \times 10^{10}$ ,  $5 \times 10^{10}$ ,  $6 \times 10^{10}$ ,  $7 \times 10^{10}$ ,  $8 \times 10^{10}$ ,  $9 \times 10^{10}$ ,  
 15  $1 \times 10^{11}$ ,  $2 \times 10^{11}$ ,  $3 \times 10^{11}$ ,  $4 \times 10^{11}$ ,  $5 \times 10^{11}$ ,  $6 \times 10^{11}$ ,  $7 \times 10^{11}$ ,  $8 \times 10^{11}$ ,  $9 \times 10^{11}$ ,  $1 \times 10^{12}$ ,  $2 \times 10^{12}$ ,  $3 \times 10^{12}$ ,  $4 \times 10^{12}$ ,  $5 \times 10^{12}$ ,  $6 \times 10^{12}$ ,  $7 \times 10^{12}$ ,  $8 \times 10^{12}$ ,  $9 \times 10^{12}$ ,  $1 \times 10^{13}$ ,  $2 \times 10^{13}$ ,  $3 \times 10^{13}$ ,  $4 \times 10^{13}$ ,  $5 \times 10^{13}$ ,  $6 \times 10^{13}$ ,  $7 \times 10^{13}$ ,  $8 \times 10^{13}$ , and  $9 \times 10^{13}$ . In an embodiment, the number of the TILs provided in the pharmaceutical compositions of the invention is in the range of  $1 \times 10^6$  to  $5 \times 10^6$ ,  $5 \times 10^6$  to  $1 \times 10^7$ ,  $1 \times 10^7$  to  $5 \times 10^7$ ,  $5 \times 10^7$  to  $1 \times 10^8$ ,  $1 \times 10^8$  to  $5 \times 10^8$ ,  $5 \times 10^8$  to  $1 \times 10^9$ ,  
 20  $1 \times 10^9$  to  $5 \times 10^9$ ,  $5 \times 10^9$  to  $1 \times 10^{10}$ ,  $1 \times 10^{10}$  to  $5 \times 10^{10}$ ,  $5 \times 10^{10}$  to  $1 \times 10^{11}$ ,  $5 \times 10^{11}$  to  $1 \times 10^{12}$ ,  $1 \times 10^{12}$  to  $5 \times 10^{12}$ , and  $5 \times 10^{12}$  to  $1 \times 10^{13}$ .

**[00366]** In some embodiments, the concentration of the TILs provided in the pharmaceutical compositions of the invention is less than, for example, 100%, 90%, 80%, 70%, 60%, 50%, 40%, 30%, 20%, 19%, 18%, 17%, 16%, 15%, 14%, 13%, 12%, 11%, 10%, 9%, 8%, 7%, 6%,  
 25 5%, 4%, 3%, 2%, 1%, 0.5%, 0.4%, 0.3%, 0.2%, 0.1%, 0.09%, 0.08%, 0.07%, 0.06%, 0.05%, 0.04%, 0.03%, 0.02%, 0.01%, 0.009%, 0.008%, 0.007%, 0.006%, 0.005%, 0.004%, 0.003%, 0.002%, 0.001%, 0.0009%, 0.0008%, 0.0007%, 0.0006%, 0.0005%, 0.0004%, 0.0003%, 0.0002% or 0.0001% w/w, w/v or v/v of the pharmaceutical composition.

**[00367]** In some embodiments, the concentration of the TILs provided in the pharmaceutical compositions of the invention is greater than 90%, 80%, 70%, 60%, 50%, 40%, 30%, 20%,  
 30 19.75%, 19.50%, 19.25% 19%, 18.75%, 18.50%, 18.25% 18%, 17.75%, 17.50%, 17.25% 17%, 16.75%, 16.50%, 16.25% 16%, 15.75%, 15.50%, 15.25% 15%, 14.75%, 14.50%,

14.25% 14%, 13.75%, 13.50%, 13.25% 13%, 12.75%, 12.50%, 12.25% 12%, 11.75%,  
 11.50%, 11.25% 11%, 10.75%, 10.50%, 10.25% 10%, 9.75%, 9.50%, 9.25% 9%, 8.75%,  
 8.50%, 8.25% 8%, 7.75%, 7.50%, 7.25% 7%, 6.75%, 6.50%, 6.25% 6%, 5.75%, 5.50%,  
 5.25% 5%, 4.75%, 4.50%, 4.25%, 4%, 3.75%, 3.50%, 3.25%, 3%, 2.75%, 2.50%, 2.25%,  
 5 2%, 1.75%, 1.50%, 1.25%, 1%, 0.5%, 0.4%, 0.3%, 0.2%, 0.1%, 0.09%, 0.08%, 0.07%,  
 0.06%, 0.05%, 0.04%, 0.03%, 0.02%, 0.01%, 0.009%, 0.008%, 0.007%, 0.006%, 0.005%,  
 0.004%, 0.003%, 0.002%, 0.001%, 0.0009%, 0.0008%, 0.0007%, 0.0006%, 0.0005%,  
 0.0004%, 0.0003%, 0.0002% or 0.0001% w/w, w/v, or v/v of the pharmaceutical  
 composition.

10 **[00368]** In some embodiments, the concentration of the TILs provided in the pharmaceutical  
 compositions of the invention is in the range from about 0.0001% to about 50%, about  
 0.001% to about 40%, about 0.01% to about 30%, about 0.02% to about 29%, about 0.03% to  
 about 28%, about 0.04% to about 27%, about 0.05% to about 26%, about 0.06% to about  
 25%, about 0.07% to about 24%, about 0.08% to about 23%, about 0.09% to about 22%,  
 15 about 0.1% to about 21%, about 0.2% to about 20%, about 0.3% to about 19%, about 0.4% to  
 about 18%, about 0.5% to about 17%, about 0.6% to about 16%, about 0.7% to about 15%,  
 about 0.8% to about 14%, about 0.9% to about 12% or about 1% to about 10% w/w, w/v or  
 v/v of the pharmaceutical composition.

**[00369]** In some embodiments, the concentration of the TILs provided in the pharmaceutical  
 20 compositions of the invention is in the range from about 0.001% to about 10%, about 0.01%  
 to about 5%, about 0.02% to about 4.5%, about 0.03% to about 4%, about 0.04% to about  
 3.5%, about 0.05% to about 3%, about 0.06% to about 2.5%, about 0.07% to about 2%, about  
 0.08% to about 1.5%, about 0.09% to about 1%, about 0.1% to about 0.9% w/w, w/v or v/v of  
 the pharmaceutical composition.

25 **[00370]** In some embodiments, the amount of the TILs provided in the pharmaceutical  
 compositions of the invention is equal to or less than 10 g, 9.5 g, 9.0 g, 8.5 g, 8.0 g, 7.5 g, 7.0  
 g, 6.5 g, 6.0 g, 5.5 g, 5.0 g, 4.5 g, 4.0 g, 3.5 g, 3.0 g, 2.5 g, 2.0 g, 1.5 g, 1.0 g, 0.95 g, 0.9 g,  
 0.85 g, 0.8 g, 0.75 g, 0.7 g, 0.65 g, 0.6 g, 0.55 g, 0.5 g, 0.45 g, 0.4 g, 0.35 g, 0.3 g, 0.25 g, 0.2  
 g, 0.15 g, 0.1 g, 0.09 g, 0.08 g, 0.07 g, 0.06 g, 0.05 g, 0.04 g, 0.03 g, 0.02 g, 0.01 g, 0.009 g,  
 30 0.008 g, 0.007 g, 0.006 g, 0.005 g, 0.004 g, 0.003 g, 0.002 g, 0.001 g, 0.0009 g, 0.0008 g,  
 0.0007 g, 0.0006 g, 0.0005 g, 0.0004 g, 0.0003 g, 0.0002 g, or 0.0001 g.

- [00371] In some embodiments, the amount of the TILs provided in the pharmaceutical compositions of the invention is more than 0.0001 g, 0.0002 g, 0.0003 g, 0.0004 g, 0.0005 g, 0.0006 g, 0.0007 g, 0.0008 g, 0.0009 g, 0.001 g, 0.0015 g, 0.002 g, 0.0025 g, 0.003 g, 0.0035 g, 0.004 g, 0.0045 g, 0.005 g, 0.0055 g, 0.006 g, 0.0065 g, 0.007 g, 0.0075 g, 0.008 g, 0.0085 g, 0.009 g, 0.0095 g, 0.01 g, 0.015 g, 0.02 g, 0.025 g, 0.03 g, 0.035 g, 0.04 g, 0.045 g, 0.05 g, 0.055 g, 0.06 g, 0.065 g, 0.07 g, 0.075 g, 0.08 g, 0.085 g, 0.09 g, 0.095 g, 0.1 g, 0.15 g, 0.2 g, 0.25 g, 0.3 g, 0.35 g, 0.4 g, 0.45 g, 0.5 g, 0.55 g, 0.6 g, 0.65 g, 0.7 g, 0.75 g, 0.8 g, 0.85 g, 0.9 g, 0.95 g, 1 g, 1.5 g, 2 g, 2.5, 3 g, 3.5, 4 g, 4.5 g, 5 g, 5.5 g, 6 g, 6.5 g, 7 g, 7.5 g, 8 g, 8.5 g, 9 g, 9.5 g, or 10 g.
- 10 [00372] The TILs provided in the pharmaceutical compositions of the invention are effective over a wide dosage range. The exact dosage will depend upon the route of administration, the form in which the compound is administered, the gender and age of the subject to be treated, the body weight of the subject to be treated, and the preference and experience of the attending physician. The clinically-established dosages of the TILs may also be used if
- 15 appropriate. The amounts of the pharmaceutical compositions administered using the methods herein, such as the dosages of TILs, will be dependent on the human or mammal being treated, the severity of the disorder or condition, the rate of administration, the disposition of the active pharmaceutical ingredients and the discretion of the prescribing physician.
- 20 [00373] In some embodiments, TILs may be administered in a single dose. Such administration may be by injection, *e.g.*, intravenous injection. In some embodiments, TILs may be administered in multiple doses. Dosing may be once, twice, three times, four times, five times, six times, or more than six times per year. Dosing may be once a month, once every two weeks, once a week, or once every other day. Administration of TILs may
- 25 continue as long as necessary.
- [00374] In some embodiments, an effective dosage of TILs is about  $1 \times 10^6$ ,  $2 \times 10^6$ ,  $3 \times 10^6$ ,  $4 \times 10^6$ ,  $5 \times 10^6$ ,  $6 \times 10^6$ ,  $7 \times 10^6$ ,  $8 \times 10^6$ ,  $9 \times 10^6$ ,  $1 \times 10^7$ ,  $2 \times 10^7$ ,  $3 \times 10^7$ ,  $4 \times 10^7$ ,  $5 \times 10^7$ ,  $6 \times 10^7$ ,  $7 \times 10^7$ ,  $8 \times 10^7$ ,  $9 \times 10^7$ ,  $1 \times 10^8$ ,  $2 \times 10^8$ ,  $3 \times 10^8$ ,  $4 \times 10^8$ ,  $5 \times 10^8$ ,  $6 \times 10^8$ ,  $7 \times 10^8$ ,  $8 \times 10^8$ ,  $9 \times 10^8$ ,  $1 \times 10^9$ ,  $2 \times 10^9$ ,  $3 \times 10^9$ ,  $4 \times 10^9$ ,  $5 \times 10^9$ ,  $6 \times 10^9$ ,  $7 \times 10^9$ ,  $8 \times 10^9$ ,  $9 \times 10^9$ ,  $1 \times 10^{10}$ ,  $2 \times 10^{10}$ ,  $3 \times 10^{10}$ ,  $4 \times 10^{10}$ ,  $5 \times 10^{10}$ ,  $6 \times 10^{10}$ ,  $7 \times 10^{10}$ ,  $8 \times 10^{10}$ ,  $9 \times 10^{10}$ ,  $1 \times 10^{11}$ ,  $2 \times 10^{11}$ ,  $3 \times 10^{11}$ ,  $4 \times 10^{11}$ ,  $5 \times 10^{11}$ ,  $6 \times 10^{11}$ ,  $7 \times 10^{11}$ ,  $8 \times 10^{11}$ ,  $9 \times 10^{11}$ ,  $1 \times 10^{12}$ ,  $2 \times 10^{12}$ ,  $3 \times 10^{12}$ ,  $4 \times 10^{12}$ ,  $5 \times 10^{12}$ ,  $6 \times 10^{12}$ ,  $7 \times 10^{12}$ ,  $8 \times 10^{12}$ ,  $9 \times 10^{12}$ ,  $1 \times 10^{13}$ ,  $2 \times 10^{13}$ ,  $3 \times 10^{13}$ ,  $4 \times 10^{13}$ ,  $5 \times 10^{13}$ ,  $6 \times 10^{13}$ ,  $7 \times 10^{13}$ ,  $8 \times 10^{13}$ , and  $9 \times 10^{13}$ . In some
- 30

embodiments, an effective dosage of TILs is in the range of  $1 \times 10^6$  to  $5 \times 10^6$ ,  $5 \times 10^6$  to  $1 \times 10^7$ ,  $1 \times 10^7$  to  $5 \times 10^7$ ,  $5 \times 10^7$  to  $1 \times 10^8$ ,  $1 \times 10^8$  to  $5 \times 10^8$ ,  $5 \times 10^8$  to  $1 \times 10^9$ ,  $1 \times 10^9$  to  $5 \times 10^9$ ,  $5 \times 10^9$  to  $1 \times 10^{10}$ ,  $1 \times 10^{10}$  to  $5 \times 10^{10}$ ,  $5 \times 10^{10}$  to  $1 \times 10^{11}$ ,  $5 \times 10^{11}$  to  $1 \times 10^{12}$ ,  $1 \times 10^{12}$  to  $5 \times 10^{12}$ , and  $5 \times 10^{12}$  to  $1 \times 10^{13}$ .

5 [00375] In some embodiments, an effective dosage of TILs is in the range of about 0.01 mg/kg to about 4.3 mg/kg, about 0.15 mg/kg to about 3.6 mg/kg, about 0.3 mg/kg to about 3.2 mg/kg, about 0.35 mg/kg to about 2.85 mg/kg, about 0.15 mg/kg to about 2.85 mg/kg, about 0.3 mg to about 2.15 mg/kg, about 0.45 mg/kg to about 1.7 mg/kg, about 0.15 mg/kg to about 1.3 mg/kg, about 0.3 mg/kg to about 1.15 mg/kg, about 0.45 mg/kg to about 1 mg/kg,  
 10 about 0.55 mg/kg to about 0.85 mg/kg, about 0.65 mg/kg to about 0.8 mg/kg, about 0.7 mg/kg to about 0.75 mg/kg, about 0.7 mg/kg to about 2.15 mg/kg, about 0.85 mg/kg to about 2 mg/kg, about 1 mg/kg to about 1.85 mg/kg, about 1.15 mg/kg to about 1.7 mg/kg, about 1.3 mg/kg mg to about 1.6 mg/kg, about 1.35 mg/kg to about 1.5 mg/kg, about 2.15 mg/kg to about 3.6 mg/kg, about 2.3 mg/kg to about 3.4 mg/kg, about 2.4 mg/kg to about 3.3 mg/kg,  
 15 about 2.6 mg/kg to about 3.15 mg/kg, about 2.7 mg/kg to about 3 mg/kg, about 2.8 mg/kg to about 3 mg/kg, or about 2.85 mg/kg to about 2.95 mg/kg.

[00376] In some embodiments, an effective dosage of TILs is in the range of about 1 mg to about 500 mg, about 10 mg to about 300 mg, about 20 mg to about 250 mg, about 25 mg to about 200 mg, about 1 mg to about 50 mg, about 5 mg to about 45 mg, about 10 mg to about  
 20 40 mg, about 15 mg to about 35 mg, about 20 mg to about 30 mg, about 23 mg to about 28 mg, about 50 mg to about 150 mg, about 60 mg to about 140 mg, about 70 mg to about 130 mg, about 80 mg to about 120 mg, about 90 mg to about 110 mg, or about 95 mg to about 105 mg, about 98 mg to about 102 mg, about 150 mg to about 250 mg, about 160 mg to about 240 mg, about 170 mg to about 230 mg, about 180 mg to about 220 mg, about 190 mg to  
 25 about 210 mg, about 195 mg to about 205 mg, or about 198 to about 207 mg.

[00377] An effective amount of the TILs may be administered in either single or multiple doses by any of the accepted modes of administration of agents having similar utilities, including intranasal and transdermal routes, by intra-arterial injection, intravenously, intraperitoneally, parenterally, intramuscularly, subcutaneously, topically, by transplantation,  
 30 or by inhalation.

## G. Optional Cell Viability Analyses

[00378] Optionally, a cell viability assay can be performed after the Step B first expansion, using standard assays known in the art. For example, a trypan blue exclusion assay can be done on a sample of the bulk TILs, which selectively labels dead cells and allows a viability assessment. Other assays for use in testing viability can include but are not limited to the Alamar blue assay; and the MTT assay.

#### 1. Cell Counts, Viability, Flow Cytometry

[00379] In some embodiments, cell counts and/or viability are measured. The expression of markers such as but not limited CD3, CD4, CD8, and CD56, as well as any other disclosed or described herein, can be measured by flow cytometry with antibodies, for example but not limited to those commercially available from BD Bio-sciences (BD Biosciences, San Jose, CA) using a FACSCanto™ flow cytometer (BD Biosciences). The cells can be counted manually using a disposable c-chip hemocytometer (VWR, Batavia, IL) and viability can be assessed using any method known in the art, including but not limited to trypan blue staining.

[00380] In some cases, the bulk TIL population can be cryopreserved immediately, using the protocols discussed below. Alternatively, the bulk TIL population can be subjected to REP and then cryopreserved as discussed below. Similarly, in the case where genetically modified TILs will be used in therapy, the bulk or REP TIL populations can be subjected to genetic modifications for suitable treatments.

#### 2. Cell Cultures

[00381] In an embodiment, a method for expanding TILs may include using about 5,000 mL to about 25,000 mL of cell medium, about 5,000 mL to about 10,000 mL of cell medium, or about 5,800 mL to about 8,700 mL of cell medium. In an embodiment, expanding the number of TILs uses no more than one type of cell culture medium. Any suitable cell culture medium may be used, e.g., AIM-V cell medium (L-glutamine, 50  $\mu$ M streptomycin sulfate, and 10  $\mu$ M gentamicin sulfate) cell culture medium (Invitrogen, Carlsbad CA). In this regard, the inventive methods advantageously reduce the amount of medium and the number of types of medium required to expand the number of TIL. In an embodiment, expanding the number of TIL may comprise adding fresh cell culture media to the cells (also referred to as feeding the cells) no more frequently than every third or fourth day. Expanding the number of cells in a gas permeable container simplifies the procedures necessary to expand the number of cells by reducing the feeding frequency necessary to expand the cells.

- [00382] In an embodiment, the cell medium in the first and/or second gas permeable container is unfiltered. The use of unfiltered cell medium may simplify the procedures necessary to expand the number of cells. In an embodiment, the cell medium in the first and/or second gas permeable container lacks beta-mercaptoethanol (BME).
- 5 [00383] In an embodiment, the duration of the method comprising obtaining a tumor tissue sample from the mammal; culturing the tumor tissue sample in a first gas permeable container containing cell medium therein; obtaining TILs from the tumor tissue sample; expanding the number of TILs in a second gas permeable container containing cell medium therein using aAPCs for a duration of about 14 to about 42 days, *e.g.*, about 28 days.
- 10 [00384] In an embodiment, TILs are expanded in gas-permeable containers. Gas-permeable containers have been used to expand TILs using PBMCs using methods, compositions, and devices known in the art, including those described in U.S. Patent Application Publication No. 2005/0106717 A1, the disclosures of which are incorporated herein by reference. In an embodiment, TILs are expanded in gas-permeable bags. In an embodiment, TILs are
- 15 expanded using a cell expansion system that expands TILs in gas permeable bags, such as the Xuri Cell Expansion System W25 (GE Healthcare). In an embodiment, TILs are expanded using a cell expansion system that expands TILs in gas permeable bags, such as the WAVE Bioreactor System, also known as the Xuri Cell Expansion System W5 (GE Healthcare). In an embodiment, the cell expansion system includes a gas permeable cell bag with a volume
- 20 selected from the group consisting of about 100 mL, about 200 mL, about 300 mL, about 400 mL, about 500 mL, about 600 mL, about 700 mL, about 800 mL, about 900 mL, about 1 L, about 2 L, about 3 L, about 4 L, about 5 L, about 6 L, about 7 L, about 8 L, about 9 L, and about 10 L. In an embodiment, TILs can be expanded in G-Rex flasks (commercially available from Wilson Wolf Manufacturing). Such embodiments allow for cell populations to
- 25 expand from about  $5 \times 10^5$  cells/cm<sup>2</sup> to between  $10 \times 10^6$  and  $30 \times 10^6$  cells/cm<sup>2</sup>. In an embodiment this expansion is conducted without adding fresh cell culture media to the cells (also referred to as feeding the cells). In an embodiment, this is without feeding so long as medium resides at a height of about 10 cm in the G-Rex flask. In an embodiment this is without feeding but with the addition of one or more cytokines. In an embodiment, the
- 30 cytokine can be added as a bolus without any need to mix the cytokine with the medium. Such containers, devices, and methods are known in the art and have been used to expand TILs, and include those described in U.S. Patent Application Publication No. US

2014/0377739A1, International Publication No. WO 2014/210036 A1, U.S. Patent Application Publication No. us 2013/0115617 A1, International Publication No. WO 2013/188427 A1, U.S. Patent Application Publication No. US 2011/0136228 A1, U.S. Patent No. US 8,809,050 B2, International publication No. WO 2011/072088 A2, U.S. Patent Application Publication No. US 2016/0208216 A1, U.S. Patent Application Publication No. US 2012/0244133 A1, International Publication No. WO 2012/129201 A1, U.S. Patent Application Publication No. US 2013/0102075 A1, U.S. Patent No. US 8,956,860 B2, International Publication No. WO 2013/173835 A1, U.S. Patent Application Publication No. US 2015/0175966 A1, the disclosures of which are incorporated herein by reference. Such processes are also described in Jin *et al.*, *J. Immunotherapy*, **2012**, 35:283-292. Optional Genetic Engineering of TILs

**[00385]** In some embodiments, the TILs are optionally genetically engineered to include additional functionalities, including, but not limited to, a high-affinity T cell receptor (TCR), *e.g.*, a TCR targeted at a tumor-associated antigen such as MAGE-1, HER2, or NY-ESO-1, or a chimeric antigen receptor (CAR) which binds to a tumor-associated cell surface molecule (*e.g.*, mesothelin) or lineage-restricted cell surface molecule (*e.g.*, CD19).

#### H. Optional Cryopreservation of TILs

**[00386]** As discussed above, and exemplified in Steps A through E as provided in Figure 27, cryopreservation can occur at numerous points throughout the TIL expansion process. In some embodiments, the expanded population of TILs after the second expansion (as provided for example, according to Step D of Figure 27) can be cryopreserved. Cryopreservation can be generally accomplished by placing the TIL population into a freezing solution, *e.g.*, 85% complement inactivated AB serum and 15% dimethyl sulfoxide (DMSO). The cells in solution are placed into cryogenic vials and stored for 24 hours at -80 °C, with optional transfer to gaseous nitrogen freezers for cryopreservation. See Sadeghi, *et al.*, *Acta Oncologica* **2013**, 52, 978-986. In some embodiments, the TILs are cryopreserved in 5% DMSO. In some embodiments, the TILs are cryopreserved in cell culture media plus 5% DMSO. In some embodiments, the TILs are cryopreserved according to the methods provided in Examples 8 and 9.

**[00387]** When appropriate, the cells are removed from the freezer and thawed in a 37 °C water bath until approximately 4/5 of the solution is thawed. The cells are generally

resuspended in complete media and optionally washed one or more times. In some embodiments, the thawed TILs can be counted and assessed for viability as is known in the art.

## 5 I. Phenotypic Characteristics of Expanded TILs

[00388] In some embodiment, the TILs are analyzed for expression of numerous phenotype markers after expansion, including those described herein and in the Examples. In an embodiment, expression of one or more phenotypic markers is examined. In some embodiments, the phenotypic characteristics of the TILs are analyzed after the first expansion  
10 in Step B. In some embodiments, the phenotypic characteristics of the TILs are analyzed during the transition in Step C. In some embodiments, the phenotypic characteristics of the TILs are analyzed during the transition according to Step C and after cryopreservation. In some embodiments, the phenotypic characteristics of the TILs are analyzed after the second expansion according to Step D. In some embodiments, the phenotypic characteristics of the  
15 TILs are analyzed after two or more expansions according to Step D. In some embodiments, the marker is selected from the group consisting of TCRab (*i.e.*, TCR $\alpha/\beta$ ), CD57, CD28, CD4, CD27, CD56, CD8a, CD45RA, CD8a, CCR7, CD4, CD3, CD38, and HLA-DR. In some embodiments, the marker is selected from the group consisting of TCRab (*i.e.*, TCR $\alpha/\beta$ ), CD57, CD28, CD4, CD27, CD56, and CD8a. In an embodiment, the marker is  
20 selected from the group consisting of CD45RA, CD8a, CCR7, CD4, CD3, CD38, and HLA-DR. In some embodiments, expression of one, two, three, four, five, six, seven, eight, nine, ten, eleven, twelve, thirteen, or fourteen markers is examined. In some embodiments, the expression from one or more markers from each group is examined. In some embodiments, one or more of HLA-DR, CD38, and CD69 expression is maintained (*i.e.*, does not exhibit a  
25 statistically significant difference) in fresh TILs as compared to thawed TILs. In some embodiments, the activation status of TILs is maintained in the thawed TILs.

[00389] In an embodiment, expression of one or more regulatory markers is measured. In some embodiments, the regulatory marker is selected from the group consisting of CD137, CD8a, Lag3, CD4, CD3, PD-1, TIM-3, CD69, CD8a, TIGIT, CD4, CD3, KLRG1, and  
30 CD154. In some embodiments, the regulatory marker is selected from the group consisting of CD137, CD8a, Lag3, CD4, CD3, PD-1, and TIM-3. In some embodiments, the regulatory marker is selected from the group consisting of CD69, CD8a, TIGIT, CD4, CD3, KLRG1,

and CD154. In some embodiments, regulatory molecule expression is decreased in thawed TILs as compared to fresh TILs. In some embodiments, expression of regulatory molecules LAG-3 and TIM-3 is decreased in thawed TILs as compared to fresh TILs. In some  
5 some embodiments, there is no significant difference in CD4, CD8, NK, TCR $\alpha\beta$  expression, and/or memory markers in fresh TILs as compared to thawed TILs. In some embodiments, there is no significant difference in CD4, CD8, NK, TCR $\alpha\beta$  expression between the TILs produced by the methods provided herein, as exemplified for example in Figure 27, and/or TILs prepared using other methods than those provide herein including for example, methods  
10 other than those embodied in Figure 27.

**[00390]** In some emodiments, no selection of the first population of TILs, second population of TILs, third population of TILs, harvested TIL population, and/or the therapeutic TIL population based on CD4, CD8, and/or NK, TCR $\alpha\beta$  expression is performed during any of steps, including those discussed above or as provided for example in Figure 27. In some  
15 embodiments, no selection of the first population of TILs based on CD4, CD8, and/or NK, TCR $\alpha\beta$  is performed. In some embodiments, no selection of the second population of TILs based on CD4, CD8, and/or NK, TCR $\alpha\beta$  expression is performed. In some embodiments, no selection of the third population of TILs based on CD4, CD8, and/or NK, TCR $\alpha\beta$  expression is performed. In some embodiments, no selection of the harvested population of TILs based  
20 on CD4, CD8, and/or NK, TCR $\alpha\beta$  expression is performed. In some embodiments, no selection of the therapeutic population of TILs based on CD4, CD8, and/or NK, TCR $\alpha\beta$  expression is performed.

**[00391]** In an embodiment, no selection of the first population of TILs, second population of TILs, third population of TILs, or harvested TIL population based on CD4, CD8, and/or NK, TCR $\alpha\beta$  expression is performed during any of steps (a) to (f) of the method for expanding  
25 tumor infiltrating lymphocytes (TILs) into a therapeutic population of TILs comprising:

- (a) obtaining a first population of TILs from a tumor resected from a patient by processing a tumor sample obtained from the patient into multiple tumor fragments;
- 30 (b) adding the tumor fragments into a closed system;
- (c) performing a first expansion by culturing the first population of TILs in a cell culture medium comprising IL-2 to produce a second population of TILs, wherein

- the first expansion is performed in a closed container providing a first gas-permeable surface area, wherein the first expansion is performed for about 3-14 days to obtain the second population of TILs, wherein the second population of TILs is at least 50-fold greater in number than the first population of TILs, and wherein the transition from step (b) to step (c) occurs without opening the system;
- 5 (d) performing a second expansion by supplementing the cell culture medium of the second population of TILs with additional IL-2, OKT-3, and antigen presenting cells (APCs), to produce a third population of TILs, wherein the second expansion is performed for about 7-14 days to obtain the third population of TILs, wherein
- 10 the third population of TILs is a therapeutic population of TILs which comprises an increased subpopulation of effector T cells and/or central memory T cells relative to the second population of TILs, wherein the second expansion is performed in a closed container providing a second gas-permeable surface area, and wherein the transition from step (c) to step (d) occurs without opening the
- 15 system;
- (e) harvesting the therapeutic population of TILs obtained from step (d), wherein the transition from step (d) to step (e) occurs without opening the system; and
- (f) transferring the harvested TIL population from step (e) to an infusion bag, wherein the transfer from step (e) to (f) occurs without opening the system.
- 20 **[00392]** In an embodiment, no selection of the first population of TILs, second population of TILs, third population of TILs, or harvested TIL population based on CD4, CD8, and/or NK, TCR $\alpha\beta$  expression is performed during any of steps (a) to (h) of the method for treating a subject with cancer, the method comprising administering expanded tumor infiltrating lymphocytes (TILs) comprising:
- 25 (a) obtaining a first population of TILs from a tumor resected from a subject by processing a tumor sample obtained from the patient into multiple tumor fragments;
- (b) adding the tumor fragments into a closed system;
- (c) performing a first expansion by culturing the first population of TILs in a cell
- 30 culture medium comprising IL-2 to produce a second population of TILs, wherein the first expansion is performed in a closed container providing a first gas-permeable surface area, wherein the first expansion is performed for about 3-14

- days to obtain the second population of TILs, wherein the second population of TILs is at least 50-fold greater in number than the first population of TILs, and wherein the transition from step (b) to step (c) occurs without opening the system;
- 5 (d) performing a second expansion by supplementing the cell culture medium of the second population of TILs with additional IL-2, OKT-3, and antigen presenting cells (APCs), to produce a third population of TILs, wherein the second expansion is performed for about 7-14 days to obtain the third population of TILs, wherein the third population of TILs is a therapeutic population of TILs which comprises an increased subpopulation of effector T cells and/or central memory T cells
- 10 relative to the second population of TILs, wherein the second expansion is performed in a closed container providing a second gas-permeable surface area, and wherein the transition from step (c) to step (d) occurs without opening the system;
- (e) harvesting the therapeutic population of TILs obtained from step (d), wherein the
- 15 transition from step (d) to step (e) occurs without opening the system; and
- (f) transferring the harvested TIL population from step (e) to an infusion bag, wherein the transfer from step (e) to (f) occurs without opening the system;
- (g) optionally cryopreserving the infusion bag comprising the harvested TIL population from step (f) using a cryopreservation process; and
- 20 (h) administering a therapeutically effective dosage of the third population of TILs from the infusion bag in step (g) to the patient.

**[00393]** In some embodiments the memory marker is selected from the group consisting of CCR7 and CD62L

**[00394]** In some embodiments, the viability of the fresh TILs as compared to the thawed

25 TILs is at least 70%, at least 75%, at least 80%, at least 85%, at least 90%, at least 95%, or at least 98%. In some embodiments, the viability of both the fresh and thawed TILs is greater than 70%, greater than 75%, greater than 80%, greater than 85%, greater than 90%, greater than 95%, or greater than 98%. In some embodiments, the viability of both the fresh and thawed product is greater than 80%, greater than 81%, greater than 82%, greater than 83%,

30 greater than 84%, greater than 85%, greater than 86%, greater than 87%, greater than 88%, greater than 89%, or greater than 90%. In some embodiments, the viability of both the fresh and thawed product is greater than 86%.

[00395] In an embodiment, restimulated TILs can also be evaluated for cytokine release, using cytokine release assays. In some embodiments, TILs can be evaluated for interferon-7 (IFN-7) secretion in response to stimulation either with OKT3 or co-culture with autologous tumor digest. For example, in embodiments employing OKT3 stimulation, TILs are washed extensively, and duplicate wells are prepared with  $1 \times 10^5$  cells in 0.2 mL CM in 96-well flat-bottom plates precoated with 0.1 or 1.0  $\mu\text{g/mL}$  of OKT3 diluted in phosphate-buffered saline. After overnight incubation, the supernatants are harvested and IFN-7 in the supernatant is measured by ELISA (Pierce/Endogen, Woburn, MA). For the co-culture assay,  $1 \times 10^5$  TIL cells are placed into a 96-well plate with autologous tumor cells. (1:1 ratio). After a 24-hour incubation, supernatants are harvested and IFN-7 release can be quantified, for example by ELISA.

[00396] Flow cytometric analysis of cell surface biomarkers: TIL samples were aliquoted for flow cytometric analysis of cell surface markers see, for Example see Examples 7, 8, and 9.

[00397] In some embodiments, the TILs are being evaluated for various regulatory markers. In some embodiments, the regulatory marker is selected from the group consisting of TCR  $\alpha/\beta$ , CD56, CD27, CD28, CD57, CD45RA, CD45RO, CD25, CD127, CD95, IL-2R-, CCR7, CD62L, KLRG1, and CD122. In some embodiments, the regulatory marker is TCR  $\alpha/\beta$ . In some embodiments, the regulatory marker is CD56. In some embodiments, the regulatory marker is CD27. In some embodiments, the regulatory marker is CD28. In some embodiments, the regulatory marker is CD57. In some embodiments, the regulatory marker is CD45RA. In some embodiments, the regulatory marker is CD45RO. In some embodiments, the regulatory marker is CD25. In some embodiments, the regulatory marker is CD127. In some embodiments, the regulatory marker is CD95. In some embodiments, the regulatory marker is IL-2R-. In some embodiments, the regulatory marker is CCR7. In some embodiments, the regulatory marker is CD62L. In some embodiments, the regulatory marker is KLRG1. In some embodiments, the regulatory marker is CD122.

[00398] In an embodiment, the expanded TILs are analyzed for expression of numerous phenotype markers, including those described herein and in the Examples. In an embodiment, expression of one or more phenotypic markers is examined. In some embodiments, the marker is selected from the group consisting of TCRab (*i.e.*, TCR $\alpha/\beta$ ), CD57, CD28, CD4, CD27, CD56, CD8a, CD45RA, CD8a, CCR7, CD4, CD3, CD38, and HLA-DR. In some embodiments, the marker is selected from the group consisting of TCRab

(*i.e.*, TCR $\alpha/\beta$ ), CD57, CD28, CD4, CD27, CD56, and CD8a. In an embodiment, the marker is selected from the group consisting of CD45RA, CD8a, CCR7, CD4, CD3, CD38, and HLA-DR. In some embodiments, expression of one, two, three, four, five, six, seven, eight, nine, ten, eleven, twelve, thirteen, or fourteen markers is examined. In some embodiments, the expression from one or more markers from each group is examined. In some  
5       embodiments, one or more of HLA-DR, CD38, and CD69 expression is maintained (*i.e.*, does not exhibit a statistically significant difference) in fresh TILs as compared to thawed TILs. In some embodiments, the activation status of TILs is maintained in the thawed TILs.

**[00399]** In an embodiment, expression of one or more regulatory markers is measured. In  
10       some embodiments, the regulatory marker is selected from the group consisting of CD137, CD8a, Lag3, CD4, CD3, PD1, TIM-3, CD69, CD8a, TIGIT, CD4, CD3, KLRG1, and CD154. In some embodiments, the regulatory marker is selected from the group consisting of CD137, CD8a, Lag3, CD4, CD3, PD1, and TIM-3. In some embodiments, the regulatory marker is selected from the group consisting of CD69, CD8a, TIGIT, CD4, CD3, KLRG1,  
15       and CD154. In some embodiments, regulatory molecule expression is decreased in thawed TILs as compared to fresh TILs. In some embodiments, expression of regulatory molecules LAG-3 and TIM-3 is decreased in thawed TILs as compared to fresh TILs. In some embodiments, there is no significant difference in CD4, CD8, NK, TCR $\alpha/\beta$  expression. In some embodiments, there is no significant difference in CD4, CD8, NK, TCR $\alpha/\beta$  expression,  
20       and/or memory markers in fresh TILs as compared to thawed TILs.

**[00400]** In some embodiments the memory marker is selected from the group consisting of CCR7 and CD62L.

**[00401]** In some embodiments, the viability of the fresh TILs as compared to the thawed TILs is at least 70%, at least 75%, at least 80%, at least 85%, at least 90%, at least 95%, or at  
25       least 98%. In some embodiments, the viability of both the fresh and thawed TILs is greater than 70%, greater than 75%, greater than 80%, greater than 85%, greater than 90%, greater than 95%, or greater than 98%. In some embodiments, the viability of both the fresh and thawed product is greater than 80%, greater than 81%, greater than 82%, greater than 83%,  
30       greater than 84%, greater than 85%, greater than 86%, greater than 87%, greater than 88%, greater than 89%, or greater than 90%. In some embodiments, the viability of both the fresh and thawed product is greater than 86%.

[00402] In an embodiment, restimulated TILs can also be evaluated for cytokine release, using cytokine release assays. In some embodiments, TILs can be evaluated for interferon-7 (IFN-7) secretion in response to stimulation either with OKT3 or coculture with autologous tumor digest. For example, in embodiments employing OKT3 stimulation, TILs are washed  
5 extensively, and duplicate wells are prepared with  $1 \times 10^5$  cells in 0.2 mL CM in 96-well flat-bottom plates precoated with 0.1 or 1.0  $\mu\text{g/mL}$  of OKT3 diluted in phosphate-buffered saline. After overnight incubation, the supernatants are harvested and IFN-7 in the supernatant is measured by ELISA (Pierce/Endogen, Woburn, MA). For the coculture assay,  $1 \times 10^5$  TIL cells are placed into a 96-well plate with autologous tumor cells. (1:1 ratio). After a 24-hour  
10 incubation, supernatants are harvested and IFN-7 release can be quantified, for example by ELISA.

[00403] In some embodiments, the phenotypic characterization is examined after cryopreservation.

#### 15 J. Metabolic Health of Expanded TILs

[00404] The restimulated TILs are characterized by significant enhancement of basal glycolysis as compared to either freshly harvested TILs and/or post-thawed TILs. In an embodiment, no selection of the first population of TILs, second population of TILs, third  
20 population of TILs, harvested TIL population, and/or the therapeutic TIL population based on CD8 expression is performed during any of steps, including those discussed above or as provided for example in Figure 27. In some embodiments, no selection of the first population of TILs based on CD8 expression is performed. In some embodiments, no selection of the second population of TILs based on CD8 expression is performed. In some embodiments, no selection of the third population of TILs based on CD8 expression is performed. In some  
25 embodiments, no selection of the harvested population of TILs based on CD8 expression is performed. In some embodiments, no selection of the therapeutic population of TILs based on CD8 expression is performed.

[00405] In an embodiment, no selection of the first population of TILs, second population of TILs, third population of TILs, or harvested TIL population based on CD8 expression is  
30 performed during any of steps (a) to (f) of the method for expanding tumor infiltrating lymphocytes (TILs) into a therapeutic population of TILs comprising:

- (a) obtaining a first population of TILs from a tumor resected from a patient by

processing a tumor sample obtained from the patient into multiple tumor fragments;

(b) adding the tumor fragments into a closed system;

5 (c) performing a first expansion by culturing the first population of TILs in a cell culture medium comprising IL-2 to produce a second population of TILs, wherein the first expansion is performed in a closed container providing a first gas-permeable surface area, wherein the first expansion is performed for about 3-14 days to obtain the second population of TILs, wherein the second population of TILs is at least 50-fold greater in number than the first population of TILs, and  
10 wherein the transition from step (b) to step (c) occurs without opening the system;

(d) performing a second expansion by supplementing the cell culture medium of the second population of TILs with additional IL-2, OKT-3, and antigen presenting cells (APCs), to produce a third population of TILs, wherein the second expansion is performed for about 7-14 days to obtain the third population of TILs, wherein  
15 the third population of TILs is a therapeutic population of TILs which comprises an increased subpopulation of effector T cells and/or central memory T cells relative to the second population of TILs, wherein the second expansion is performed in a closed container providing a second gas-permeable surface area, and wherein the transition from step (c) to step (d) occurs without opening the  
20 system;

(e) harvesting the therapeutic population of TILs obtained from step (d), wherein the transition from step (d) to step (e) occurs without opening the system; and

(f) transferring the harvested TIL population from step (e) to an infusion bag, wherein the transfer from step (e) to (f) occurs without opening the system.

25 **[00406]** In an embodiment, no selection of the first population of TILs, second population of TILs, third population of TILs, or harvested TIL population based on CD8 expression is performed during any of steps (a) to (h) of the method for treating a subject with cancer, the method comprising administering expanded tumor infiltrating lymphocytes (TILs) comprising:

30 (a) obtaining a first population of TILs from a tumor resected from a subject by processing a tumor sample obtained from the patient into multiple tumor fragments;

- (b) adding the tumor fragments into a closed system;
- (c) performing a first expansion by culturing the first population of TILs in a cell culture medium comprising IL-2 to produce a second population of TILs, wherein the first expansion is performed in a closed container providing a first gas-permeable surface area, wherein the first expansion is performed for about 3-14 days to obtain the second population of TILs, wherein the second population of TILs is at least 50-fold greater in number than the first population of TILs, and wherein the transition from step (b) to step (c) occurs without opening the system;
- (d) performing a second expansion by supplementing the cell culture medium of the second population of TILs with additional IL-2, OKT-3, and antigen presenting cells (APCs), to produce a third population of TILs, wherein the second expansion is performed for about 7-14 days to obtain the third population of TILs, wherein the third population of TILs is a therapeutic population of TILs which comprises an increased subpopulation of effector T cells and/or central memory T cells relative to the second population of TILs, wherein the second expansion is performed in a closed container providing a second gas-permeable surface area, and wherein the transition from step (c) to step (d) occurs without opening the system;
- (e) harvesting the therapeutic population of TILs obtained from step (d), wherein the transition from step (d) to step (e) occurs without opening the system; and
- (f) transferring the harvested TIL population from step (e) to an infusion bag, wherein the transfer from step (e) to (f) occurs without opening the system;
- (g) optionally cryopreserving the infusion bag comprising the harvested TIL population from step (f) using a cryopreservation process; and
- (h) administering a therapeutically effective dosage of the third population of TILs from the infusion bag in step (g) to the patient.

[00407] The TILs prepared by the methods described herein are characterized by significant enhancement of basal glycolysis as compared to, for example, freshly harvested TILs and/or TILs prepared using other methods than those provide herein including for example, methods other than those embodied in Figure 27. In an embodiment, no selection of the first population of TILs, second population of TILs, third population of TILs, harvested TIL population, and/or the therapeutic TIL population based on CD8 expression is performed

during any of steps, including those discussed above or as provided for example in Figure 27. In some embodiments, no selection of the first population of TILs based on CD8 expression is performed. In some embodiments, no selection of the second population of TILs based on CD8 expression is performed. In some embodiments, no selection of the third population of TILs based on CD8 expression is performed. In some embodiments, no selection of the harvested population of TILs based on CD8 expression is performed. In some embodiments, no selection of the therapeutic population of TILs based on CD8 expression is performed. In an embodiment, no selection of the first population of TILs, second population of TILs, third population of TILs, or harvested TIL population based on CD8 expression is performed during any of steps (a) to (h).

[00408] Spare respiratory capacity (SRC) and glycolytic reserve can be evaluated for TILs expanded with different methods of the present disclosure. The Seahorse XF Cell Mito Stress Test measures mitochondrial function by directly measuring the oxygen consumption rate (OCR) of cells, using modulators of respiration that target components of the electron transport chain in the mitochondria. The test compounds (oligomycin, FCCP, and a mix of rotenone and antimycin A, described below) are serially injected to measure ATP production, maximal respiration, and non-mitochondrial respiration, respectively. Proton leak and spare respiratory capacity are then calculated using these parameters and basal respiration. Each modulator targets a specific component of the electron transport chain. Oligomycin inhibits ATP synthase (complex V) and the decrease in OCR following injection of oligomycin correlates to the mitochondrial respiration associated with cellular ATP production. Carbonyl cyanide-4 (trifluoromethoxy) phenylhydrazone (FCCP) is an uncoupling agent that collapses the proton gradient and disrupts the mitochondrial membrane potential. As a result, electron flow through the electron transport chain is uninhibited and oxygen is maximally consumed by complex IV. The FCCP-stimulated OCR can then be used to calculate spare respiratory capacity, defined as the difference between maximal respiration and basal respiration. Spare respiratory capacity (SRC) is a measure of the ability of the cell to respond to increased energy demand. The third injection is a mix of rotenone, a complex I inhibitor, and antimycin A, a complex III inhibitor. This combination shuts down mitochondrial respiration and enables the calculation of nonmitochondrial respiration driven by processes outside the mitochondria. In some embodiments, the comparison is to, for example, freshly harvested

TILs and/or TILs prepared using other methods than those provide herein including for example, methods other than those embodied in Figure 27.

[00409] In some embodiments, the metabolic assay is basal respiration. In general, second expansion TILs have a basal respiration rate that is at least 50%, at least 55%, at least 60%, at least 65%, at least 70%, at least 75%, at least 80%, at least 85%, at least 90%, at least 95%, at least 97%, at least 98%, or at least 99% of the basal respiration rate of freshly harvested TILs and/or TILs prepared using other methods than those provide herein including for example, methods other than those embodied in Figure 27. In some embodiments, the basal respiration rate is from about 50% to about 99% of the basal respiration rate of freshly harvested TILs and/or TILs prepared using other methods than those provide herein including for example, methods other than those embodied in Figure 27. In some embodiments, the basal respiration rate is from about 60% to about 99% of the basal respiration rate of freshly harvested TILs and/or TILs prepared using other methods than those provide herein including for example, methods other than those embodied in Figure 27. In some embodiments, the basal respiration rate is from about 70% to about 99% of the basal respiration rate of freshly harvested TILs and/or TILs prepared using other methods than those provide herein including for example, methods other than those embodied in Figure 27. In some embodiments, the basal respiration rate is from about 80% to about 99% of the basal respiration rate of freshly harvested TILs and/or TILs prepared using other methods than those provide herein including for example, methods other than those embodied in Figure 27. In some embodiments, the basal respiration rate is from about 90% to about 99% of the basal respiration rate of freshly harvested TILs and/or TILs prepared using other methods than those provide herein including for example, methods other than those embodied in Figure 27. In some embodiments, the basal respiration rate is from about 95% to about 99% of the basal respiration rate of freshly harvested TILs and/or TILs prepared using other methods than those provide herein including for example, methods other than those embodied in Figure 27. In some embodiments, the second expansion TILs or second additional expansion TILs (such as, for example, those described in Step D of Figure 27, including TILs referred to as reREP TILs) have a basal respiration rate that is not statistically significantly different than the basal respiration rate of freshly harvested TILs and/or TILs prepared using other methods than those provide herein including for example, methods other than those embodied in Figure 27. In some embodiments, the comparison is to, for example, freshly harvested TILs and/or TILs prepared

using other methods than those provide herein including for example, methods other than those embodied in Figure 27.

[00410] In some embodiments, the metabolic assay is spare respiratory capacity. In general, the second expansion TILs or second additional expansion TILs (such as, for example, those described in Step D of Figure 27, including TILs referred to as reREP TILs) have a spare respiratory capacity that is at least is at least 50%, at least 55%, at least 60%, at least 65%, at least 70%, at least 75%, at least 80%, at least 85%, at least 90%, at least 95%, at least 97%, at least 98%, or at least 99% of the basal respiration rate of freshly harvested TILs and/or TILs prepared using other methods than those provide herein including for example, methods other than those embodied in Figure 27. In some embodiments, the spare respiratory capacity is from about 50% to about 99% of the *basal respiration rate* of freshly harvested TILs. In some embodiments, the spare respiratory capacity is from about 50% to about 99% of the *basal respiration rate* of freshly harvested TILs and/or TILs prepared using other methods than those provide herein including for example, methods other than those embodied in Figure 27. In some embodiments, the spare respiratory capacity is from about 60% to about 99% of the *basal respiration rate* of freshly harvested TILs and/or TILs prepared using other methods than those provide herein including for example, methods other than those embodied in Figure 27. In some embodiments, the spare respiratory capacity is from about 70% to about 99% of the *basal respiration rate* of freshly harvested TILs and/or TILs prepared using other methods than those provide herein including for example, methods other than those embodied in Figure 27. In some embodiments, the spare respiratory capacity is from about 80% to about 99% of the *basal respiration rate* of freshly harvested TILs. In some embodiments, the spare respiratory capacity is from about 90% to about 99% of the *basal respiration rate* of freshly harvested TILs and/or TILs prepared using other methods than those provide herein including for example, methods other than those embodied in Figure 27. In some embodiments, the spare respiratory capacity is from about 95% to about 99% of the *basal respiration rate* of freshly harvested TILs and/or TILs prepared using other methods than those provide herein including for example, methods other than those embodied in Figure 27. In some embodiments, the second expansion TILs or second additional expansion TILs (such as, for example, those described in Step D of Figure 27, including TILs referred to as reREP TILs) have a spare respiratory capacity that is not statistically significantly different than the *basal respiration rate* of freshly harvested TILs and/or TILs prepared using other

methods than those provide herein including for example, methods other than those embodied in Figure 27.

[00411] In general, second expansion TILs or second additional expansion TILs (such as, for example, those described in Step D of Figure 27, including TILs referred to as reREP TILs) have a spare respiratory capacity that is at least is at least 50%, at least 55%, at least 60%, at least 65%, at least 70%, at least 75%, at least 80%, at least 85%, at least 90%, at least 95%, at least 97%, at least 98%, or at least 99% of the basal respiration rate of freshly harvested TILs and/or TILs prepared using other methods than those provide herein including for example, methods other than those embodied in Figure 27. In some embodiments, the metabolic assay measured is glycolytic reserve. In some embodiments, the metabolic assay is spare respiratory capacity. To measure cellular (respiratory) metabolism cells were treated with inhibitors of mitochondrial respiration and glycolysis to determine a metabolic profile for the TIL consisting of the following measures: baseline oxidative phosphorylation (as measured by OCR), spare respiratory capacity, baseline glycolytic activity (as measured by ECAR), and glycolytic reserve. Metabolic profiles were performed using the Seahorse Combination Mitochondrial/Glycolysis Stress Test Assay (including the kit commercially available from Agilent®), which allows for determining a cells' capacity to perform glycolysis upon blockage of mitochondrial ATP production. In some embodiments, cells are starved of glucose, then glucose is injected, followed by a stress agent. In some embodiments, the stress agent is selected from the group consisting of oligomycin, FCCP, rotenone, antimycin A and/or 2-deoxyglucose (2-DG), as well as combinations thereof. In some embodiments, oligomycin is added at 10 mM. In some embodiments, FCCP is added at 10 mM. In some embodiments, rotenone is added at 2.5 mM. In some embodiments, antimycin A is added at 2.5 mM. In some embodiments, 2-deoxyglucose (2-DG) is added at 500 mM. In some embodiments, glycolytic capacity, glycolytic reserve, and/or non-glycolytic acidification are measured. In general, TILs have a glycolytic reserve that is at least 50%, at least 55%, at least 60%, at least 65%, at least 70%, at least 75%, at least 80%, at least 85%, at least 90%, at least 95%, at least 97%, at least 98%, or at least 99% of the basal respiration rate of freshly harvested TILs and/or TILs prepared using other methods than those provide herein including for example, methods other than those embodied in Figure 27. In some embodiments, the glycolytic reserve is from about 50% to about 99% of the *basal respiration rate* of freshly harvested TILs and/or TILs prepared using other

methods than those provide herein including for example, methods other than those embodied in Figure 27. In some embodiments, the glycolytic reserve is from about 60% to about 99% of the *basal respiration rate* of freshly harvested TILs and/or TILs prepared using other methods than those provide herein including for example, methods other than those embodied in Figure 27. In some embodiments, the glycolytic reserve is from about 70% to about 99% of the *basal respiration rate* of freshly harvested TILs and/or TILs prepared using other methods than those provide herein including for example, methods other than those embodied in Figure 27. In some embodiments, the glycolytic reserve is from about 80% to about 99% of the *basal respiration rate* of freshly harvested TILs and/or TILs prepared using other methods than those provide herein including for example, methods other than those embodied in Figure 27. In some embodiments, the glycolytic reserve is from about 90% to about 99% of the *basal respiration rate* of freshly harvested TILs and/or TILs prepared using other methods than those provide herein including for example, methods other than those embodied in Figure 27. In some embodiments, the glycolytic reserve is from about 95% to about 99% of the *basal respiration rate* of freshly harvested TILs and/or TILs prepared using other methods than those provide herein including for example, methods other than those embodied in Figure 27.

[00412] In some embodiments, the metabolic assay is basal glycolysis. In some embodiments, second expansion TILs or second additional expansion TILs (such as, for example, those described in Step D of Figure 27, including TILs referred to as reREP TILs) have an increase in basal glycolysis of at least two-fold, at least three-fold, at least four-fold, at least five-fold, at least six-fold, at least 7-fold, at least eight-fold, at least nine-fold, or at least ten-fold as compared to freshly harvested TILs and/or TILs prepared using other methods than those provide herein including for example, methods other than those embodied in Figure 27. In some embodiments, the second expansion TILs or second additional expansion TILs (such as, for example, those described in Step D of Figure 27, including TILs referred to as reREP TILs) have an increase in basal glycolysis of about two-fold to about ten-fold as compared to freshly harvested TILs and/or TILs prepared using other methods than those provide herein including for example, methods other than those embodied in Figure 27. In some embodiments, the second expansion TILs or second additional expansion TILs (such as, for example, those described in Step D of Figure 27, including TILs referred to as reREP TILs) have an increase in basal glycolysis of about two-fold to about eight-fold as

compared to freshly harvested TILs and/or TILs prepared using other methods than those provide herein including for example, methods other than those embodied in Figure 27. In some embodiments, second expansion TILs or second additional expansion TILs (such as, for example, those described in Step D of Figure 27, including TILs referred to as reREP TILs) 5 have an increase in basal glycolysis of about three-fold to about seven-fold as compared to freshly harvested TILs and/or TILs prepared using other methods than those provide herein including for example, methods other than those embodied in Figure 27. In some 10 embodiments, the second expansion TILs or second additional expansion TILs (such as, for example, those described in Step D of Figure 27, including TILs referred to as reREP TILs) have an increase in basal glycolysis of about two-fold to about four-fold as compared to 15 freshly harvested TILs and/or TILs prepared using other methods than those provide herein including for example, methods other than those embodied in Figure 27.

[00413] In general, the second expansion TILs or second additional expansion TILs (such as, for example, those described in Step D of Figure 27, including TILs referred to as reREP 20 TILs) have a glycolytic reserve that is at least 50%, at least 55%, at least 60%, at least 65%, at least 70%, at least 75%, at least 80%, at least 85%, at least 90%, at least 95%, at least 97%, at least 98%, or at least 99% of the basal respiration rate of freshly harvested TILs and/or TILs prepared using other methods than those provide herein including for example, 25 methods other than those embodied in Figure 27. In some embodiments, the glycolytic reserve is from about 50% to about 99% of the *basal respiration rate* of freshly harvested TILs. In some embodiments, the glycolytic reserve is from about 60% to about 99% of the *basal respiration rate* of freshly harvested TILs and/or TILs prepared using other methods 30 than those provide herein including for example, methods other than those embodied in Figure 27. In some embodiments, the glycolytic reserve is from about 70% to about 99% of the *basal respiration rate* of freshly harvested TILs and/or TILs prepared using other methods than those provide herein including for example, methods other than those embodied in Figure 27. In some embodiments, the glycolytic reserve is from about 80% to about 99%

of the *basal respiration rate* of freshly harvested TILs and/or TILs prepared using other methods than those provide herein including for example, methods other than those embodied in Figure 27. In some embodiments, the glycolytic reserve is from about 90% to about 99% of the *basal respiration rate* of freshly harvested TILs and/or TILs prepared using other methods than those provide herein including for example, methods other than those embodied in Figure 27. In some embodiments, the glycolytic reserve is from about 95% to about 99% of the *basal respiration rate* of freshly harvested TILs.

**[00414]** Granzyme B Production: Granzyme B is another measure of the ability of TIL to kill target cells. Media supernatants restimulated as described above using antibodies to CD3, CD28, and CD137/4-1BB were also evaluated for their levels of Granzyme B using the Human Granzyme B DuoSet ELISA Kit (R & D Systems, Minneapolis, MN) according to the manufacturer's instructions. In some embodiments, the second expansion TILs or second additional expansion TILs (such as, for example, those described in Step D of Figure 27, including TILs referred to as reREP TILs) have increased Granzyme B production. In some embodiments, the second expansion TILs or second additional expansion TILs (such as, for example, those described in Step D of Figure 27, including TILs referred to as reREP TILs) have increased cytotoxic activity.

**[00415]** In some embodiments, telomere length can be used as a measure of cell viability and/or cellular function. In some embodiments, the telomeres are surprisingly the same length in the TILs produced by the present invention as compared to TILs prepared using other methods than those provide herein including for example, methods other than those embodied in Figure 27. Telomere length measurement: Diverse methods have been used to measure the length of telomeres in genomic DNA and cytological preparations. The telomere restriction fragment (TRF) analysis is the gold standard to measure telomere length (de Lange et al., 1990). However, the major limitation of TRF is the requirement of a large amount of DNA (1.5  $\mu$ g). Two widely used techniques for the measurement of telomere lengths namely, fluorescence in situ hybridization (FISH; Agilent Technologies, Santa Clara, CA) and quantitative PCR can be employed with the present invention. In some embodiments, there is no change in telomere length between the initially harvest TILs in Step A and the expanded TILs from for example Step D as provided in Figure 27.

**[00416]** In some embodiments, TIL health is measured by IFN-gamma (IFN- $\gamma$ ) secretion. In some embodiments, IFN- $\gamma$  secretion is indicative of active TILs. In some embodiments, a

potency assay for IFN- $\gamma$  production is employed. IFN- $\gamma$  production is another measure of cytotoxic potential. IFN- $\gamma$  production can be measured by determining the levels of the cytokine IFN- $\gamma$  in the media of TIL stimulated with antibodies to CD3, CD28, and CD137/4-1BB. IFN- $\gamma$  levels in media from these stimulated TIL can be determined using by measuring IFN- $\gamma$  release. In some embodiments, an increase in IFN- $\gamma$  production in for example Step D as provided in Figure 27 TILs as compared to initially harvested TILs in for example Step A as provided in Figure 27 is indicative of an increase in cytotoxic potential of the Step D TILs. In some embodiments, IFN- $\gamma$  secretion is increased one-fold, two-fold, three-fold, four-fold, or five-fold or more. In some embodiments, IFN- $\gamma$  secretion is increased one-fold. In some embodiments, IFN- $\gamma$  secretion is increased two-fold. In some embodiments, IFN- $\gamma$  secretion is increased three-fold. In some embodiments, IFN- $\gamma$  secretion is increased four-fold. In some embodiments, IFN- $\gamma$  secretion is increased five-fold. In some embodiments, IFN- $\gamma$  is measured using a Quantikine ELISA kit. In some embodiments, IFN- $\gamma$  is measured in TILs *ex vivo*. In some embodiments, IFN- $\gamma$  is measured in TILs *ex vivo*, including TILs produced by the methods of the present invention, including for example Figure 27 methods, as well as freshly harvested TILs or those TILs produced by other methods, such as those provided for example in Figure 83 (such as for example process 1C TILs).

[00417] In some embodiments, the cytotoxic potential of TIL to lyse target cells was assessed using a co-culture assay of TIL with the bioluminescent cell line, P815 (Clone G6), according to a bioluminescent redirected lysis assay (potency assay) for TIL assay which measures TIL cytotoxicity in a highly sensitive dose dependent manner.

[00418] In some embodiments, the present methods provide an assay for assessing TIL viability, using the methods as described above. In some embodiments, the TILs are expanded as discussed above, including for example as provided in Figure 27. In some embodiments, the TILs are cryopreserved prior to being assessed for viability. In some embodiments, the viability assessment includes thawing the TILs prior to performing a first expansion, a second expansion, and an additional second expansion. In some embodiments, the present methods provide an assay for assessing cell proliferation, cell toxicity, cell death, and/or other terms related to viability of the TIL population. Viability can be measured by any of the TIL metabolic assays described above as well as any methods known for assessing cell viability that are known in the art. In some embodiments, the present methods provide as

assay for assessment of cell proliferation, cell toxicity, cell death, and/or other terms related to viability of the TILs expanded using the methods described herein, including those exemplified in Figure 27.

[00419] The present invention also provides assay methods for determining TIL viability. In some embodiments, the TILs have equal viability as compared to freshly harvested TILs and/or TILs prepared using other methods than those provide herein including for example, methods other than those embodied in Figure 27. In some embodiments, the TILs have increased viability as compared to freshly harvested TILs and/or TILs prepared using other methods than those provide herein including for example, methods other than those embodied in Figure 27. The present disclosure provides methods for assaying TILs for viability by expanding tumor infiltrating lymphocytes (TILs) into a larger population of TILs comprising:

- (i) obtaining a first population of TILs which has been previously expanded;
- (ii) performing a first expansion by culturing the first population of TILs in a cell culture medium comprising IL-2 to produce a second population of TILs; and
- (iii) performing a second expansion by supplementing the cell culture medium of the second population of TILs with additional IL-2, OKT-3, and antigen presenting cells (APCs), to produce a third population of TILs, wherein the third population of TILs is at least 100-fold greater in number than the second population of TILs, and wherein the second expansion is performed for at least 14 days in order to obtain the third population of TILs, wherein the third population of TILs comprises an increased subpopulation of effector T cells and/or central memory T cells relative to the second population of TILs, and wherein the third population is further assayed for viability.

[00420] In some embodiments, the method further comprises:

- (iv) performing an additional second expansion by supplementing the cell culture medium of the third population of TILs with additional IL-2, additional OKT-3, and additional APCs, wherein the additional second expansion is performed for at least 14 days to obtain a larger population of TILs than obtained in step (iii), wherein the larger population of TILs comprises an increased subpopulation of effector T cells and/or central memory T cells relative to the third population of TILs, and wherein the third population is further assayed for viability.

[00421] In some embodiments, prior to step (i), the cells are cryopreserved.

- [00422] In some embodiments, the cells are thawed prior to performing step (i).
- [00423] In some embodiments, step (iv) is repeated one to four times in order to obtain sufficient TILs for analysis.
- [00424] In some embodiments, steps (i) through (iii) or (iv) are performed within a period of  
5 about 40 days to about 50 days.
- [00425] In some embodiments, steps (i) through (iii) or (iv) are performed within a period of about 42 days to about 48 days.
- [00426] In some embodiments, steps (i) through (iii) or (iv) are performed within a period of about 42 days to about 45 days.
- 10 [00427] In some embodiments, steps (i) through (iii) or (iv) are performed within about 44 days.
- [00428] In some embodiments, the cells from steps (iii) or (iv) express CD4, CD8, and TCR  $\alpha$   $\beta$  at levels similar to freshly harvested cells.
- [00429] In some embodiments, the antigen presenting cells are peripheral blood  
15 mononuclear cells (PBMCs).
- [00430] In some embodiments, the PBMCs are added to the cell culture on any of days 9 through 17 in step (iii).
- [00431] In some embodiments, the effector T cells and/or central memory T cells in the larger population of TILs in step (iv) exhibit one or more characteristics selected from the  
20 group consisting of expression of CD27, expression of CD28, longer telomeres, increased CD57 expression, and decreased CD56 expression, relative to effector T cells, and/or central memory T cells in the third population of cells.
- [00432] In some embodiments, the effector T cells and/or central memory T cells exhibit increased CD57 expression and decreased CD56 expression.
- 25 [00433] In some embodiments, the APCs are artificial APCs (aAPCs).
- [00434] In some embodiments, the method further comprises the step of transducing the first population of TILs with an expression vector comprising a nucleic acid encoding a high-affinity T cell receptor.
- [00435] In some embodiments, the step of transducing occurs before step (i).

- [00436] In some embodiments, the method further comprises the step of transducing the first population of TILs with an expression vector comprising a nucleic acid encoding a chimeric antigen receptor (CAR) comprising a single chain variable fragment antibody fused with at least one endodomain of a T-cell signaling molecule.
- 5 [00437] In some embodiments, the step of transducing occurs before step (i).
- [00438] In some embodiments, the TILs are assayed for viability.
- [00439] In some embodiments, the TILs are assayed for viability after cryopreservation.
- [00440] In some embodiments, the TILs are assayed for viability after cryopreservation and after step (iv).
- 10 [00441] The diverse antigen receptors of T and B lymphocytes are produced by somatic recombination of a limited, but large number of gene segments. These gene segments: V (variable), D (diversity), J (joining), and C (constant), determine the binding specificity and downstream applications of immunoglobulins and T-cell receptors (TCRs). The present invention provides a method for generating TILs which exhibit and increase the T-cell
- 15 repertoire diversity (sometimes referred to as polyclonality). In some embodiments, the increase in T-cell repertoire diversity is as compared to freshly harvested TILs and/or TILs prepared using other methods than those provide herein including for example, methods other than those embodied in Figure 27. In some embodiments, the TILs obtained by the present method exhibit an increase in the T-cell repertoire diversity. In some embodiments, the TILs
- 20 obtained in the first expansion exhibit an increase in the T-cell repertoire diversity. In some embodiments, the increase in diversity is an increase in the immunoglobulin diversity and/or the T-cell receptor diversity. In some embodiments, the diversity is in the immunoglobulin is in the immunoglobulin heavy chain. In some embodiments, the diversity is in the immunoglobulin is in the immunoglobulin light chain. In some embodiments, the diversity is
- 25 in the T-cell receptor. In some embodiments, the diversity is in one of the T-cell receptors selected from the group consisting of alpha, beta, gamma, and delta receptors. In some embodiments, there is an increase in the expression of T-cell receptor (TCR) alpha and/or beta. In some embodiments, there is an increase in the expression of T-cell receptor (TCR) alpha. In some embodiments, there is an increase in the expression of T-cell receptor (TCR) beta. In some embodiments, there is an increase in the expression of TCRab (*i.e.*, TCR $\alpha/\beta$ ).
- 30

[00442] According to the present disclosure, a method for assaying TILs for viability and/or further use in administration to a subject. In some embodiments, the method for assay tumor infiltrating lymphocytes (TILs) comprises:

- (i) obtaining a first population of TILs;
- 5 (ii) performing a first expansion by culturing the first population of TILs in a cell culture medium comprising IL-2 to produce a second population of TILs; and
- (iii) performing a second expansion by supplementing the cell culture medium of the second population of TILs with additional IL-2, OKT-3, and antigen presenting cells (APCs), to produce a third population of TILs, wherein the third population of TILs is  
10 at least 50-fold greater in number than the second population of TILs;
- (iv) harvesting, washing, and cryopreserving the third population of TILs;
- (v) storing the cryopreserved TILs at a cryogenic temperature;
- (vi) thawing the third population of TILs to provide a thawed third population of TILs; and
- 15 (vii) performing an additional second expansion of a portion of the thawed third population of TILs by supplementing the cell culture medium of the third population with IL-2, OKT-3, and APCs for an additional expansion period (sometimes referred to as a reREP period) of at least 3 days, wherein the third expansion is performed to obtain a fourth population of TILs, wherein the number of TILs in the fourth  
20 population of TILs is compared to the number of TILs in the third population of TILs to obtain a ratio;
- (viii) determining based on the ratio in step (vii) whether the thawed population of TILs is suitable for administration to a patient;
- (ix) administering a therapeutically effective dosage of the thawed third population of  
25 TILs to the patient when the ratio of the number of TILs in the fourth population of TILs to the number of TILs in the third population of TILs is determined to be greater than 5:1 in step (viii).

[00443] In some embodiments, the additional expansion period (sometimes referred to as a reREP period) is performed until the ratio of the number of TILs in the fourth population of  
30 TILs to the number of TILs in the third population of TILs is greater than 50:1.

[00444] In some embodiments, the number of TILs sufficient for a therapeutically effective dosage is from about  $2.3 \times 10^{10}$  to about  $13.7 \times 10^{10}$ .

[00445] In some embodiments, steps (i) through (vii) are performed within a period of about 40 days to about 50 days. In some embodiments, steps (i) through (vii) are performed within  
5 a period of about 42 days to about 48 days. In some embodiments, steps (i) through (vii) are performed within a period of about 42 days to about 45 days. In some embodiments, steps (i) through (vii) are performed within about 44 days.

[00446] In some embodiments, the cells from steps (iii) or (vii) express CD4, CD8, and TCR  $\alpha \beta$  at levels similar to freshly harvested cells. In some embodiments the cells are TILs.

10 [00447] In some embodiments, the antigen presenting cells are peripheral blood mononuclear cells (PBMCs). In some embodiments, the PBMCs are added to the cell culture on any of days 9 through 17 in step (iii).

[00448] In some embodiments, the effector T cells and/or central memory T cells in the larger population of TILs in steps (iii) or (vii) exhibit one or more characteristics selected  
15 from the group consisting of expression of CD27, expression of CD28, longer telomeres, increased CD57 expression, and decreased CD56 expression, relative to effector T cells, and/or central memory T cells in the third population of cells.

[00449] In some embodiments, the effector T cells and/or central memory T cells exhibit increased CD57 expression and decreased CD56 expression.

20 [00450] In some embodiments, the APCs are artificial APCs (aAPCs).

[00451] In some embodiments, the step of transducing the first population of TILs with an expression vector comprising a nucleic acid encoding a high-affinity T cell receptor.

[00452] In some embodiments, the step of transducing occurs before step (i).

[00453] In some embodiments, the step of transducing the first population of TILs with an  
25 expression vector comprising a nucleic acid encoding a chimeric antigen receptor (CAR) comprising a single chain variable fragment antibody fused with at least one endodomain of a T-cell signaling molecule.

[00454] In some embodiments, the step of transducing occurs before step (i).

[00455] In some embodiments, the TILs are assayed for viability after step (vii).

[00456] The present disclosure also provides further methods for assaying TILs. In some embodiments, the disclosure provides a method for assaying TILs comprising:

- (i) obtaining a portion of a first population of cryopreserved TILs;
- (ii) thawing the portion of the first population of cryopreserved TILs;
- 5 (iii) performing a first expansion by culturing the portion of the first population of TILs in a cell culture medium comprising IL-2, OKT-3, and antigen presenting cells (APCs) for an additional expansion period (sometimes referred to as a reREP period) of at least 3 days, to produce a second population of TILs, wherein the portion from the first population of TILs is compared to the second population of TILs to obtain a  
10 ratio of the number of TILs, wherein the ratio of the number of TILs in the second population of TILs to the number of TILs in the portion of the first population of TILs is greater than 5:1;
- (iv) determining based on the ratio in step (iii) whether the first population of TILs is suitable for use in therapeutic administration to a patient;
- 15 (v) determining the first population of TILs is suitable for use in therapeutic administration when the ratio of the number of TILs in the second population of TILs to the number of TILs in the first population of TILs is determined to be greater than 5:1 in step (iv).

[00457] In some embodiments, the ratio of the number of TILs in the second population of  
20 TILs to the number of TILs in the portion of the first population of TILs is greater than 50:1.

[00458] In some embodiments, the method further comprises performing expansion of the entire first population of cryopreserved TILs from step (i) according to the methods as described in any of the embodiments provided herein.

[00459] In some embodiments, the method further comprises administering the entire first  
25 population of cryopreserved TILs from step (i) to the patient.

#### **K. Closed Systems for TIL Manufacturing**

[00460] The present invention provides for the use of closed systems during the TIL culturing process. Such closed systems allow for preventing and/or reducing microbial

contamination, allow for the use of fewer flasks, and allow for cost reductions. In some embodiments, the closed system uses two containers.

[00461] Such closed systems are well-known in the art and can be found, for example, at <http://www.fda.gov/cber/guidelines.htm> and

5 <https://www.fda.gov/BiologicsBloodVaccines/GuidanceComplianceRegulatoryInformation/Guidances/Blood/ucm076779.htm..>

[00462] As provided on the FDA website, closed systems with sterile methods are known and well described. See,

10 <https://www.fda.gov/BiologicsBloodVaccines/GuidanceComplianceRegulatoryInformation/Guidances/Blood/ucm076779.htm>, as referenced above and provided in pertinent part below.

#### Introduction

[00463] Sterile connecting devices (STCDs) produce sterile welds between two pieces of compatible tubing. This procedure permits sterile connection of a variety of containers and tube diameters. This guidance describes recommended practices and procedures for use of these devices. This guidance does not address the data or information that a manufacturer of a sterile connecting device must submit to FDA in order to obtain approval or clearance for marketing. It is also important to note that the use of an approved or cleared sterile connecting device for purposes not authorized in the labeling may cause the device to be considered adulterated and misbranded under the Federal Food, Drug and Cosmetic Act.

#### 20 1. FDA Recommendations

[00464] Manufacturers of blood products who propose to routinely use an FDA-cleared STCD should incorporate information regarding such use in standard operating procedure (SOP) manuals for each blood product. These entries should include record keeping, product tracking, tube weld quality control, lot numbers of software and disposables (including source(s) of elements to be added). Quality control procedures should include a test of the integrity of each weld.

#### 2. Applications of the STCD

[00465] The user should be aware that use of the device may create a new product or significantly modify the configuration of a regulated product for which safety and efficacy have not been demonstrated. For those "new products" subject to licensure, applications, or application supplements must be submitted to FDA in addition to submission of a SOP. In

5 general, pooling or mixing that involves cellular components represents a change in the product that requires submission and approval of a license application or application supplement. Such applications and application supplements should contain data and descriptions of manufacturing procedures that demonstrate that the "new product" is safe and effective for its intended use throughout the proposed dating period.

[00466] The following comments are provided as guidance on the more common uses of an FDA cleared or approved STCD:

**L. Adding a new or smaller needle to a blood collection set**

10 [00467] Using the STCD to add a needle prior to the initiation of a procedure (whole blood collection, plateletpheresis or source plasma collection) is not considered to open a functionally closed system. If a needle is added during a procedure, only an STCD approved to weld liquid-filled tubing should be used. If the test of weld integrity is satisfactory, the use of an STCD is not considered to open a functionally closed system.

15 [00468] Platelets, Pheresis prepared in an open system should be labeled with a 24 hour outdate and Platelets, Pheresis products prepared in a functionally closed system should be labeled with a five day outdate (See Revised Guideline for Collection of Platelets, Pheresis, October 7, 1988).

20 [00469] The source and specifications of added tubing and needles should be addressed in the blood center's SOP and records. Using the STCD to add needles does not represent a major change in manufacturing for which licensed establishments need preapproval.

**M. Using the STCD to prepare components**

25 [00470] When the STCD is used to attach additional component preparation bags, records should be properly maintained identifying the source of the transfer packs and the appropriate verification of blood unit number and ABO/Rh. All blood and blood components must be appropriately labeled (21 CFR 606.121).

Examples:

- Adding a fourth bag to a whole blood collection triple-pack for the production of Cryoprecipitated AHF from Fresh Frozen Plasma.
- Connection of an additive solution to a red blood cell unit.
- 30 • Addition of an in-line filter that has been FDA cleared for use in manufacturing components.

- Addition of a third storage container to a plateletpheresis harness.
- For the above stated uses, procedures should be developed and records maintained, but licensees need not have FDA approval in order to institute the procedures.

5                   1.       **Using the STCD to pool blood products**

[00471] Appropriate use of an STCD to pool Platelets prepared from Whole Blood collection may obviate potential contamination from the spike and port entries commonly used. Pooling performed immediately before transfusion is an example of such appropriate use. Pooled Platelets should be administered not more than 4 hours after pooling (See 21 CFR  
10 606.122(l)(2)).

[00472] However, pooling and subsequent storage may increase the risk compared to administration of random donor units; if one contaminated unit is pooled with others and stored before administration, the total bacterial inoculum administered may be increased as a result of replication in the additional volume. Accordingly, the proposed use of an STCD to  
15 pool and store platelets for more than 4 hours should be supported by data which satisfactorily addresses whether such pooling is associated with increased risk.

[00473] Such platelet pooling constitutes manufacture of a new product.

[00474] Pooling or mixing that involves platelets is considered the manufacture of a new product that requires submission and approval of a license application or application  
20 supplement if the storage period is to exceed four hours.

                          2.       **Using the STCD to prepare an aliquot for pediatric use and divided units**

[00475] Pediatric units and divided units for Whole Blood, Red Blood Cells, and Fresh Frozen Plasma prepared using an STCD will not be considered a new product for which a  
25 biologics license application (BLA) supplement is required providing the following conditions are met:

The manufacturer should have an approved biologics license or license supplement, for the original (i.e., undivided) product, including approval for each anticoagulant used.

30                   Labels should be submitted for review and approval before distribution. A notation should be made under the comments section of FDA Form 2567, Transmittal of Labels and Circulars.

Final product containers approved for storage of the component being prepared should be used.

5 [00476] Platelets manufactured under licensure must contain at least  $5.5 \times (10)^{10}$  platelets (21 CFR 640.24 (c)). Platelets, Pheresis manufactured under licensure should contain at least  $3.0 \times (10)^{11}$  platelets (See Revised Guideline for the Collection of Platelets, Pheresis, October 7, 1988).

[00477] Procedures to be followed regarding the use of an STCD to prepare divided products from Whole Blood collections and from plasma and platelets prepared by automated hemapheresis procedures should include descriptions of:

- 10
- How the apheresis harness or collection container will be modified with an FDA-cleared STCD;
  - the minimum volume of the split plasma or whole blood products;
  - the volume and platelet concentration of the split plateletpheresis products;
  - 15 • storage time of the product. The product should be in an approved container and should be consistent with the storage time on the label of such container;
  - method(s) to be used to label and track divided products in the blood center's records.

20 [00478] NOTE: Procedures for labeling the aliquots should be clearly stated in the procedure record keeping should be adequate to permit tracking and recall of all components, if necessary.

3. **Using an STCD to connect additional saline or anticoagulant lines during an automated plasmapheresis procedure**

25 [00479] Procedures should be developed and records maintained consistent with the instrument manufacturer's directions for use, but licensees need not have FDA approval in order to institute the procedures.

4. **Using the STCD to attach processing solutions**

30 [00480] When using an STCD to attach containers with processing solutions to washed or frozen red blood cell products, the dating period for the resulting products is 24 hours, unless data are provided in the form of license applications or application supplements to CBER to support a longer dating period (21 CFR 610.53(c)). Exemptions or modifications must be approved in writing from the Director, CBER (21 CFR 610.53(d)).

## 5. Using an STCD to add an FDA-cleared leukocyte reduction filter

[00481] Some leuko-reduction filters are not integrally attached to the Whole Blood collection systems. Procedures for use of an STCD for pre-storage filtration should be consistent with filter manufacturers' directions for use.

- 5 [00482] Leukocyte reduction prior to issue constitutes a major manufacturing change. Therefore, for new leukocyte-reduced products prepared using an STCD, manufacturers must submit biologics license applications (21 CFR 601.2) or prior approval application supplements to FDA (21 CFR 601.12).

10 [00483] Using an STCD to remove samples from blood product containers for testing (e.g., using an STCD to obtain a sample of platelets from a container of Platelets or Platelets, Pheresis for cross matching).

[00484] If the volume and/or cell count of the product after sample withdrawal differ from what is stated on the original label or in the circular of information, the label on the product should be modified to reflect the new volume and/or cell count. For example, samples may  
15 not be removed that reduce the platelet count of a unit of Platelets to less than  $5.5 \times (10)^{10}$  platelets (21 CFR 640.24 (c)).

## 6. Additional Information from FDA Guidance

[00485] The FDA guidance presents general guidance as well as specific information and examples concerning specifications for submission of applications and application  
20 supplements to FDA addressing use of an STCD. If further questions arise concerning appropriate use of an STCD, concerns should be directed to the Office of Blood Research and Review, Center for Biologics Evaluation and Research.

[00486] In some embodiments, the closed system uses one container from the time the tumor fragments are obtained until the TILs are ready for administration to the patient or  
25 cryopreserving. In some embodiments when two containers are used, the first container is a closed G-container and the population of TILs is centrifuged and transferred to an infusion bag without opening the first closed G-container. In some embodiments, when two containers are used, the infusion bag is a HypoThermosol-containing infusion bag. A closed system or closed TIL cell culture system is characterized in that once the tumor sample  
30 and/or tumor fragments have been added, the system is tightly sealed from the outside to

form a closed environment free from the invasion of bacteria, fungi, and/or any other microbial contamination.

[00487] In some embodiments, the reduction in microbial contamination is between about 5% and about 100%. In some embodiments, the reduction in microbial contamination is  
5 between about 5% and about 95%. In some embodiments, the reduction in microbial contamination is between about 5% and about 90%. In some embodiments, the reduction in microbial contamination is between about 10% and about 90%. In some embodiments, the reduction in microbial contamination is between about 15% and about 85%. In some  
10 embodiments, the reduction in microbial contamination is about 5%, about 10%, about 15%, about 20%, about 25%, about 30%, about 35%, about 40%, about 45%, about 50%, about 55%, about 60%, about 65%, about 70%, about 75%, about 80%, about 85%, about 90%, about 95%, about 97%, about 98%, about 99%, or about 100%.

[00488] The closed system allows for TIL growth in the absence and/or with a significant reduction in microbial contamination.

15 [00489] Moreover, pH, carbon dioxide partial pressure and oxygen partial pressure of the TIL cell culture environment each vary as the cells are cultured. Consequently, even though a medium appropriate for cell culture is circulated, the closed environment still needs to be constantly maintained as an optimal environment for TIL proliferation. To this end, it is desirable that the physical factors of pH, carbon dioxide partial pressure and oxygen partial  
20 pressure within the culture liquid of the closed environment be monitored by means of a sensor, the signal whereof is used to control a gas exchanger installed at the inlet of the culture environment, and the that gas partial pressure of the closed environment be adjusted in real time according to changes in the culture liquid so as to optimize the cell culture environment. In some embodiments, the present invention provides a closed cell culture  
25 system which incorporates at the inlet to the closed environment a gas exchanger equipped with a monitoring device which measures the pH, carbon dioxide partial pressure and oxygen partial pressure of the closed environment, and optimizes the cell culture environment by automatically adjusting gas concentrations based on signals from the monitoring device.

[00490] In some embodiments, the pressure within the closed environment is continuously  
30 or intermittently controlled. That is, the pressure in the closed environment can be varied by means of a pressure maintenance device for example, thus ensuring that the space is suitable for growth of TILs in a positive pressure state, or promoting exudation of fluid in a negative

pressure state and thus promoting cell proliferation. By applying negative pressure intermittently, moreover, it is possible to uniformly and efficiently replace the circulating liquid in the closed environment by means of a temporary shrinkage in the volume of the closed environment.

- 5 [00491] In some embodiments, optimal culture components for proliferation of the TILs can be substituted or added, and including factors such as IL-2 and/or OKT3, as well as combination, can be added.

### C. Cell Cultures

10 [00492] In an embodiment, a method for expanding TILs, including those discuss above as well as exemplified in Figure 27, may include using about 5,000 mL to about 25,000 mL of cell medium, about 5,000 mL to about 10,000 mL of cell medium, or about 5,800 mL to about 8,700 mL of cell medium. In some embodiments, the media is a serum free medium, as described for example in Example 21. In some embodiments, the media in the first expansion is serum free. In some embodiments, the media in the second expansion is serum  
15 free. . In some embodiments, the media in the first expansion and the second are both serum free. In an embodiment, expanding the number of TILs uses no more than one type of cell culture medium. Any suitable cell culture medium may be used, *e.g.*, AIM-V cell medium (L-glutamine, 50  $\mu$ M streptomycin sulfate, and 10  $\mu$ M gentamicin sulfate) cell culture medium (Invitrogen, Carlsbad CA). In this regard, the inventive methods advantageously reduce the  
20 amount of medium and the number of types of medium required to expand the number of TIL. In an embodiment, expanding the number of TIL may comprise feeding the cells no more frequently than every third or fourth day. Expanding the number of cells in a gas permeable container simplifies the procedures necessary to expand the number of cells by reducing the feeding frequency necessary to expand the cells.

- 25 [00493] In an embodiment, the cell medium in the first and/or second gas permeable container is unfiltered. The use of unfiltered cell medium may simplify the procedures necessary to expand the number of cells. In an embodiment, the cell medium in the first and/or second gas permeable container lacks beta-mercaptoethanol (BME).

30 [00494] In an embodiment, the duration of the method comprising obtaining a tumor tissue sample from the mammal; culturing the tumor tissue sample in a first gas permeable container containing cell medium therein; obtaining TILs from the tumor tissue sample;

expanding the number of TILs in a second gas permeable container containing cell medium for a duration of about 7 to 14 days, *e.g.*, about 11 days. In some embodiments pre-REP is about 7 to 14 days, *e.g.*, about 11 days. In some embodiments, REP is about 7 to 14 days, *e.g.*, about 11 days.

5 [00495] In an embodiment, TILs are expanded in gas-permeable containers. Gas-permeable containers have been used to expand TILs using PBMCs using methods, compositions, and devices known in the art, including those described in U.S. Patent Application Publication No. 2005/0106717 A1, the disclosures of which are incorporated herein by reference. In an embodiment, TILs are expanded in gas-permeable bags. In an embodiment, TILs are  
10 expanded using a cell expansion system that expands TILs in gas permeable bags, such as the Xuri Cell Expansion System W25 (GE Healthcare). In an embodiment, TILs are expanded using a cell expansion system that expands TILs in gas permeable bags, such as the WAVE Bioreactor System, also known as the Xuri Cell Expansion System W5 (GE Healthcare). In an embodiment, the cell expansion system includes a gas permeable cell bag with a volume  
15 selected from the group consisting of about 100 mL, about 200 mL, about 300 mL, about 400 mL, about 500 mL, about 600 mL, about 700 mL, about 800 mL, about 900 mL, about 1 L, about 2 L, about 3 L, about 4 L, about 5 L, about 6 L, about 7 L, about 8 L, about 9 L, and about 10 L.

[00496] In an embodiment, TILs can be expanded in G-Rex flasks (commercially available  
20 from Wilson Wolf Manufacturing). Such embodiments allow for cell populations to expand from about  $5 \times 10^5$  cells/cm<sup>2</sup> to between  $10 \times 10^6$  and  $30 \times 10^6$  cells/cm<sup>2</sup>. In an embodiment this is without feeding. In an embodiment, this is without feeding so long as medium resides at a height of about 10 cm in the G-Rex flask. In an embodiment this is without feeding but with the addition of one or more cytokines. In an embodiment, the cytokine can be added as a  
25 bolus without any need to mix the cytokine with the medium. Such containers, devices, and methods are known in the art and have been used to expand TILs, and include those described in U.S. Patent Application Publication No. US 2014/0377739A1, International Publication No. WO 2014/210036 A1, U.S. Patent Application Publication No. us  
2013/0115617 A1, International Publication No. WO 2013/188427 A1, U.S. Patent  
30 Application Publication No. US 2011/0136228 A1, U.S. Patent No. US 8,809,050 B2, International publication No. WO 2011/072088 A2, U.S. Patent Application Publication No. US 2016/0208216 A1, U.S. Patent Application Publication No. US 2012/0244133 A1,

International Publication No. WO 2012/129201 A1, U.S. Patent Application Publication No. US 2013/0102075 A1, U.S. Patent No. US 8,956,860 B2, International Publication No. WO 2013/173835 A1, U.S. Patent Application Publication No. US 2015/0175966 A1, the disclosures of which are incorporated herein by reference. Such processes are also described  
5 in Jin *et al.*, *J. Immunotherapy*, **2012**, 35:283-292.

#### D. Optional Genetic Engineering of TILs

[00497] In some embodiments, the TILs are optionally genetically engineered to include additional functionalities, including, but not limited to, a high-affinity T cell receptor (TCR),  
10 *e.g.*, a TCR targeted at a tumor-associated antigen such as MAGE-1, HER2, or NY-ESO-1, or a chimeric antigen receptor (CAR) which binds to a tumor-associated cell surface molecule (*e.g.*, mesothelin) or lineage-restricted cell surface molecule (*e.g.*, CD19).

#### E. Optional Cryopreservation of TILs

15 [00498] Either the bulk TIL population or the expanded population of TILs can be optionally cryopreserved. In some embodiments, cryopreservation occurs on the therapeutic TIL population. In some embodiments, cryopreservation occurs on the TILs harvested after the second expansion. In some embodiments, cryopreservation occurs on the TILs in exemplary Step F of Figure 27. In some embodiments, the TILs are cryopreserved in the infusion bag. In  
20 some embodiments, the TILs are cryopreserved prior to placement in an infusion bag. In some embodiments, the TILs are cryopreserved and not placed in an infusion bag. In some embodiments, cryopreservation is performed using a cryopreservation medium. In some embodiments, the cryopreservation media contains dimethylsulfoxide (DMSO). This is generally accomplished by putting the TIL population into a freezing solution, *e.g.* 85%  
25 complement inactivated AB serum and 15% dimethyl sulfoxide (DMSO). The cells in solution are placed into cryogenic vials and stored for 24 hours at -80 °C, with optional transfer to gaseous nitrogen freezers for cryopreservation. See, Sadeghi, *et al.*, *Acta Oncologica* **2013**, 52, 978-986.

[00499] When appropriate, the cells are removed from the freezer and thawed in a 37 °C  
30 water bath until approximately 4/5 of the solution is thawed. The cells are generally resuspended in complete media and optionally washed one or more times. In some

embodiments, the thawed TILs can be counted and assessed for viability as is known in the art.

[00500] In a preferred embodiment, a population of TILs is cryopreserved using CS10 cryopreservation media (CryoStor 10, BioLife Solutions). In a preferred embodiment, a population of TILs is cryopreserved using a cryopreservation media containing dimethylsulfoxide (DMSO). In a preferred embodiment, a population of TILs is cryopreserved using a 1:1 (vol:vol) ratio of CS10 and cell culture media. In a preferred embodiment, a population of TILs is cryopreserved using about a 1:1 (vol:vol) ratio of CS10 and cell culture media, further comprising additional IL-2.

10 [00501] As discussed above in Steps A through E, cryopreservation can occur at numerous points throughout the TIL expansion process. In some embodiments, the bulk TIL population after the first expansion according to Step B or the expanded population of TILs after the one or more second expansions according to Step D can be cryopreserved. Cryopreservation can be generally accomplished by placing the TIL population into a freezing solution, *e.g.*, 85% complement inactivated AB serum and 15% dimethyl sulfoxide (DMSO). The cells in solution are placed into cryogenic vials and stored for 24 hours at -80 °C, with optional transfer to gaseous nitrogen freezers for cryopreservation. See Sadeghi, *et al.*, *Acta Oncologica* 2013, 52, 978-986.

15 [00502] When appropriate, the cells are removed from the freezer and thawed in a 37 °C water bath until approximately 4/5 of the solution is thawed. The cells are generally resuspended in complete media and optionally washed one or more times. In some embodiments, the thawed TILs can be counted and assessed for viability as is known in the art.

20 [00503] In some cases, the Step B TIL population can be cryopreserved immediately, using the protocols discussed below. Alternatively, the bulk TIL population can be subjected to Step C and Step D and then cryopreserved after Step D. Similarly, in the case where genetically modified TILs will be used in therapy, the Step B or Step D TIL populations can be subjected to genetic modifications for suitable treatments.

30 F. Optional Cell Viability Analyses

[00504] Optionally, a cell viability assay can be performed after the first expansion (sometimes referred to as the initial bulk expansion), using standard assays known in the art. For example, a trypan blue exclusion assay can be done on a sample of the bulk TILs, which selectively labels dead cells and allows a viability assessment. Other assays for use in testing viability can include but are not limited to the Alamar blue assay; and the MTT assay.

#### 1. Cell Counts, Viability, Flow Cytometry

[00505] In some embodiments, cell counts and/or viability are measured. The expression of markers such as but not limited CD3, CD4, CD8, and CD56, as well as any other disclosed or described herein, can be measured by flow cytometry with antibodies, for example but not limited to those commercially available from BD Bio-sciences (BD Biosciences, San Jose, CA) using a FACSCanto™ flow cytometer (BD Biosciences). The cells can be counted manually using a disposable c-chip hemocytometer (VWR, Batavia, IL) and viability can be assessed using any method known in the art, including but not limited to trypan blue staining.

[00506] In some cases, the bulk TIL population can be cryopreserved immediately, using the protocols discussed below. Alternatively, the bulk TIL population can be subjected to REP and then cryopreserved as discussed below. Similarly, in the case where genetically modified TILs will be used in therapy, the bulk or REP TIL populations can be subjected to genetic modifications for suitable treatments.

#### 2. Cell Cultures

[00507] In an embodiment, a method for expanding TILs may include using about 5,000 mL to about 25,000 mL of cell medium, about 5,000 mL to about 10,000 mL of cell medium, or about 5,800 mL to about 8,700 mL of cell medium. In an embodiment, expanding the number of TILs uses no more than one type of cell culture medium. Any suitable cell culture medium may be used, *e.g.*, AIM-V cell medium (L-glutamine, 50  $\mu$ M streptomycin sulfate, and 10  $\mu$ M gentamicin sulfate) cell culture medium (Invitrogen, Carlsbad CA). In this regard, the inventive methods advantageously reduce the amount of medium and the number of types of medium required to expand the number of TIL. In an embodiment, expanding the number of TIL may comprise feeding the cells no more frequently than every third or fourth day. Expanding the number of cells in a gas permeable container simplifies the procedures necessary to expand the number of cells by reducing the feeding frequency necessary to expand the cells.

[00508] In an embodiment, the cell medium in the first and/or second gas permeable container is unfiltered. The use of unfiltered cell medium may simplify the procedures necessary to expand the number of cells. In an embodiment, the cell medium in the first and/or second gas permeable container lacks beta-mercaptoethanol (BME).

5 [00509] In an embodiment, the duration of the method comprising obtaining a tumor tissue sample from the mammal; culturing the tumor tissue sample in a first gas permeable container containing cell medium therein; obtaining TILs from the tumor tissue sample; expanding the number of TILs in a second gas permeable container containing cell medium therein using aAPCs for a duration of about 14 to about 42 days, *e.g.*, about 28 days.

10 [00510] In an embodiment, TILs are expanded in gas-permeable containers. Gas-permeable containers have been used to expand TILs using PBMCs using methods, compositions, and devices known in the art, including those described in U.S. Patent Application Publication No. 2005/0106717 A1, the disclosures of which are incorporated herein by reference. In an embodiment, TILs are expanded in gas-permeable bags. In an embodiment, TILs are  
15 expanded using a cell expansion system that expands TILs in gas permeable bags, such as the Xuri Cell Expansion System W25 (GE Healthcare). In an embodiment, TILs are expanded using a cell expansion system that expands TILs in gas permeable bags, such as the WAVE Bioreactor System, also known as the Xuri Cell Expansion System W5 (GE Healthcare). In an embodiment, the cell expansion system includes a gas permeable cell bag with a volume  
20 selected from the group consisting of about 100 mL, about 200 mL, about 300 mL, about 400 mL, about 500 mL, about 600 mL, about 700 mL, about 800 mL, about 900 mL, about 1 L, about 2 L, about 3 L, about 4 L, about 5 L, about 6 L, about 7 L, about 8 L, about 9 L, and about 10 L.

[00511] In an embodiment, TILs can be expanded in G-Rex flasks (commercially available  
25 from Wilson Wolf Manufacturing). Such embodiments allow for cell populations to expand from about  $5 \times 10^5$  cells/cm<sup>2</sup> to between  $10 \times 10^6$  and  $30 \times 10^6$  cells/cm<sup>2</sup>. In an embodiment this is without feeding. In an embodiment, this is without feeding so long as medium resides at a height of about 10 cm in the G-Rex flask. In an embodiment this is without feeding but with the addition of one or more cytokines. In an embodiment, the cytokine can be added as a  
30 bolus without any need to mix the cytokine with the medium. Such containers, devices, and methods are known in the art and have been used to expand TILs, and include those described in U.S. Patent Application Publication No. US 2014/0377739A1, International

Publication No. WO 2014/210036 A1, U.S. Patent Application Publication No. us  
2013/0115617 A1, International Publication No. WO 2013/188427 A1, U.S. Patent  
Application Publication No. US 2011/0136228 A1, U.S. Patent No. US 8,809,050 B2,  
International publication No. WO 2011/072088 A2, U.S. Patent Application Publication No.  
5 US 2016/0208216 A1, U.S. Patent Application Publication No. US 2012/0244133 A1,  
International Publication No. WO 2012/129201 A1, U.S. Patent Application Publication No.  
US 2013/0102075 A1, U.S. Patent No. US 8,956,860 B2, International Publication No. WO  
2013/173835 A1, U.S. Patent Application Publication No. US 2015/0175966 A1, the  
disclosures of which are incorporated herein by reference. Such processes are also described  
10 in Jin *et al.*, *J. Immunotherapy*, **2012**, 35:283-292. Optional Genetic Engineering of TILs

**[00512]** In some embodiments, the TILs are optionally genetically engineered to include  
additional functionalities, including, but not limited to, a high-affinity T cell receptor (TCR),  
*e.g.*, a TCR targeted at a tumor-associated antigen such as MAGE-1, HER2, or NY-ESO-1, or  
a chimeric antigen receptor (CAR) which binds to a tumor-associated cell surface molecule  
15 (*e.g.*, mesothelin) or lineage-restricted cell surface molecule (*e.g.*, CD19).

#### IV. Methods of Treating Patients

20 **[00513]** Methods of treatment begin with the initial TIL collection and culture of TILs.  
Such methods have been both described in the art by, for example, Jin *et al.*, *J.*  
*Immunotherapy*, **2012**, 35(3):283-292, incorporated by reference herein in its entirety.  
Embodiments of methods of treatment are described throughout the sections below, including  
the Examples.

25 **[00514]** The expanded TILs produced according the methods described herein, including for  
example as described in Steps A through F above or according to Steps A through F above  
(also as shown, for example, in Figure 27) find particular use in the treatment of patients with  
cancer (for example, as described in Goff, *et al.*, *J. Clinical Oncology*, **2016**, 34(20):2389-  
239, as well as the supplemental content; incorporated by reference herein in its entirety. In  
30 some embodiments, TIL were grown from resected deposits of metastatic melanoma as  
previously described (see, Dudley, *et al.*, *J Immunother.*, **2003**, 26:332-342; incorporated by

reference herein in its entirety). Fresh tumor can be dissected under sterile conditions. A representative sample can be collected for formal pathologic analysis. Single fragments of 2 mm<sup>3</sup> to 3 mm<sup>3</sup> may be used. In some embodiments, 5, 10, 15, 20, 25 or 30 samples per patient are obtained. In some embodiments, 20, 25, or 30 samples per patient are obtained. In some embodiments, 20, 22, 24, 26, or 28 samples per patient are obtained. In some embodiments, 24 samples per patient are obtained. Samples can be placed in individual wells of a 24-well plate, maintained in growth media with high-dose IL-2 (6,000 IU/mL), and monitored for destruction of tumor and/or proliferation of TIL. Any tumor with viable cells remaining after processing can be enzymatically digested into a single cell suspension and cryopreserved, as described herein.

**[00515]** In some embodiments, successfully grown TIL can be sampled for phenotype analysis (CD3, CD4, CD8, and CD56) and tested against autologous tumor when available. TIL can be considered reactive if overnight coculture yielded interferon-gamma (IFN- $\gamma$ ) levels > 200 pg/mL and twice background. (Goff, et al., *J Immunother.*, 2010, 33:840-847; incorporated by reference herein in its entirety). In some embodiments, cultures with evidence of autologous reactivity or sufficient growth patterns can be selected for a second expansion (for example, a second expansion as provided in according to Step D of Figure 27), including second expansions that are sometimes referred to as rapid expansion (REP). In some embodiments, expanded TILs with high autologous reactivity (for example, high proliferation during a second expansion), are selected for an additional second expansion. In some embodiments, TILs with high autologous reactivity (for example, high proliferation during second expansion as provided in Step D of Figure 27), are selected for an additional second expansion according to Step D of Figure 27.

**[00516]** In some embodiments, the patient is not moved directly to ACT (adoptive cell transfer), for example, in some embodiments, after tumor harvesting and/or a first expansion, the cells are not utilized immediately. In such embodiments, TILs can be cryopreserved and thawed 2 days before administration to a patient. In such embodiments, TILs can be cryopreserved and thawed 1 day before administration to a patient. In some embodiments, the TILs can be cryopreserved and thawed immediately before the administration to a patient.

**[00517]** Cell phenotypes of cryopreserved samples of infusion bag TIL can be analyzed by flow cytometry (*e.g.*, FlowJo) for surface markers CD3, CD4, CD8, CCR7, and CD45RA (BD BioSciences), as well as by any of the methods described herein. Serum cytokines were

measured by using standard enzyme-linked immunosorbent assay techniques. A rise in serum IFN-g was defined as >100 pg/mL and greater than 4 3 baseline levels.

5 [00518] In some embodiments, the TILs produced by the methods provided herein, for example those exemplified in Figure 27, provide for a surprising improvement in clinical efficacy of the TILs. In some embodiments, the TILs produced by the methods provided herein, for example those exemplified in Figure 27, exhibit increased clinical efficacy as compared to TILs produced by methods other than those described herein, including for example, methods other than those exemplified in Figure 27. In some embodiments, the methods other than those described herein include methods referred to as process 1C and/or 10 Generation 1 (Gen 1). In some embodiments, the increased efficacy is measured by DCR, ORR, and/or other clinical responses. In some embodiments, the TILs produced by the methods provided herein, for example those exemplified in Figure 27, exhibit a similar time to response and safety profile compared to TILs produced by methods other than those described herein, including for example, methods other than those exemplified in Figure 27, 15 for example the Gen 1 process.

[00519] In some embodiments, IFN-gamma (IFN- $\gamma$ ) is indicative of treatment efficacy and/or increased clinical efficacy. In some embodiments, IFN- $\gamma$  in the blood of subjects treated with TILs is indicative of active TILs. In some embodiments, a potency assay for IFN- $\gamma$  production is employed. IFN- $\gamma$  production is another measure of cytotoxic potential. 20 IFN- $\gamma$  production can be measured by determining the levels of the cytokine IFN- $\gamma$  in the blood, serum, or TILs *ex vivo* of a subject treated with TILs prepared by the methods of the present invention, including those as described for example in Figure 27. In some embodiments, an increase in IFN- $\gamma$  is indicative of treatment efficacy in a patient treated with the TILs produced by the methods of the present invention. In some embodiments, IFN- $\gamma$  is 25 increased one-fold, two-fold, three-fold, four-fold, or five-fold or more as compared to an untreated patient and/or as compared to a patient treated with TILs prepared using other methods than those provide herein including for example, methods other than those embodied in Figure 27. In some embodiments, IFN- $\gamma$  secretion is increased one-fold as compared to an untreated patient and/or as compared to a patient treated with TILs prepared using other 30 methods than those provide herein including for example, methods other than those embodied in Figure 27. In some embodiments, IFN- $\gamma$  secretion is increased two-fold as compared to an untreated patient and/or as compared to a patient treated with TILs prepared using other

methods than those provide herein including for example, methods other than those embodied in Figure 27. In some embodiments, IFN- $\gamma$  secretion is increased three-fold as compared to an untreated patient and/or as compared to a patient treated with TILs prepared using other methods than those provide herein including for example, methods other than those embodied in Figure 27. In some embodiments, IFN- $\gamma$  secretion is increased four-fold as compared to an untreated patient and/or as compared to a patient treated with TILs prepared using other methods than those provide herein including for example, methods other than those embodied in Figure 27. In some embodiments, IFN- $\gamma$  secretion is increased five-fold as compared to an untreated patient and/or as compared to a patient treated with TILs prepared using other methods than those provide herein including for example, methods other than those embodied in Figure 27. In some embodiments, IFN- $\gamma$  is measured using a Quantikine ELISA kit. In some embodiments, IFN- $\gamma$  is measured in TILs *ex vivo* of a subject treated with TILs prepared by the methods of the present invention, including those as described for example in Figure 27. In some embodiments, IFN- $\gamma$  is measured in blood of a subject treated with TILs prepared by the methods of the present invention, including those as described for example in Figure 27. In some embodiments, IFN- $\gamma$  is measured in TILs serum of a subject treated with TILs prepared by the methods of the present invention, including those as described for example in Figure 27.

**[00520]** In some embodiments, higher average IP-10 is indicative of treatment efficacy and/or increased clinical efficacy. In some embodiments, higher average IP-10 in the blood of subjects treated with TILs is indicative of active TILs. IP-10 production can be measured by determining the levels of the IP-10 in the blood of a subject treated with TILs prepared by the methods of the present invention, including those as described for example in Figure 27. In some embodiments, higher average IP-10 is indicative of treatment efficacy in a patient treated with the TILs produced by the methods of the present invention. In some embodiments, higher average IP-10 correlates to an increase of one-fold, two-fold, three-fold, four-fold, or five-fold or more as compared to an untreated patient and/or as compared to a patient treated with TILs prepared using other methods than those provide herein including for example, methods other than those embodied in Figure 27. In some embodiments, higher average IP-10 correlates to an increase of one-fold as compared to an untreated patient and/or as compared to a patient treated with TILs prepared using other methods than those provide herein including for example, methods other than those embodied in Figure 27. In some

embodiments, higher average IP-10 correlates to an increase of two-fold as compared to an untreated patient and/or as compared to a patient treated with TILs prepared using other methods than those provide herein including for example, methods other than those embodied in Figure 27. In some embodiments, higher average IP-10 correlates to an increase of three-fold as compared to an untreated patient and/or as compared to a patient treated with TILs prepared using other methods than those provide herein including for example, methods other than those embodied in Figure 27. In some embodiments, higher average IP-10 correlates to an increase of four-fold as compared to an untreated patient and/or as compared to a patient treated with TILs prepared using other methods than those provide herein including for example, methods other than those embodied in Figure 27. In some embodiments, higher average IP-10 correlates to an increase of five-fold as compared to an untreated patient and/or as compared to a patient treated with TILs prepared using other methods than those provide herein including for example, methods other than those embodied in Figure 27. In some embodiments, IP-10 is measured in blood of a subject treated with TILs prepared by the methods of the present invention, including those as described for example in Figure 27. In some embodiments, IP-10 is measured in TILs serum of a subject treated with TILs prepared by the methods of the present invention, including those as described for example in Figure 27.

**[00521]** In some embodiments, higher average MCP-1 is indicative of treatment efficacy and/or increased clinical efficacy. In some embodiments, higher average MCP-1 in the blood of subjects treated with TILs is indicative of active TILs. MCP-1 production can be measured by determining the levels of the MCP-1 in the blood of a subject treated with TILs prepared by the methods of the present invention, including those as described for example in Figure 27. In some embodiments, higher average MCP-1 is indicative of treatment efficacy in a patient treated with the TILs produced by the methods of the present invention. In some embodiments, higher average MCP-1 correlates to an increase of one-fold, two-fold, three-fold, four-fold, or five-fold or more as compared to an untreated patient and/or as compared to a patient treated with TILs prepared using other methods than those provide herein including for example, methods other than those embodied in Figure 27. In some embodiments, higher average MCP-1 correlates to an increase of one-fold as compared to an untreated patient and/or as compared to a patient treated with TILs prepared using other methods than those provide herein including for example, methods other than those embodied

in Figure 27. In some embodiments, higher average MCP-1 correlates to an increase of two-fold as compared to an untreated patient and/or as compared to a patient treated with TILs prepared using other methods than those provide herein including for example, methods other than those embodied in Figure 27. In some embodiments, higher average MCP-1 correlates to an increase of three-fold as compared to an untreated patient and/or as compared to a patient treated with TILs prepared using other methods than those provide herein including for example, methods other than those embodied in Figure 27. In some embodiments, higher average MCP-1 correlates to an increase of four-fold as compared to an untreated patient and/or as compared to a patient treated with TILs prepared using other methods than those provide herein including for example, methods other than those embodied in Figure 27. In some embodiments, higher average MCP-1 correlates to an increase of five-fold as compared to an untreated patient and/or as compared to a patient treated with TILs prepared using other methods than those provide herein including for example, methods other than those embodied in Figure 27. In some embodiments, MCP-1 is measured in blood of a subject treated with TILs prepared by the methods of the present invention, including those as described for example in Figure 27. In some embodiments, MCP-1 is measured in TILs serum of a subject treated with TILs prepared by the methods of the present invention, including those as described for example in Figure 27.

[00522] In some embodiments, the TILs prepared by the methods of the present invention, including those as described for example in Figure 27, exhibit increased polyclonality as compared to TILs produced by other methods, including those not exemplified in Figure 27, such as for example, methods referred to as process 1C methods. In some embodiments, significantly improved polyclonality and/or increased polyclonality is indicative of treatment efficacy and/or increased clinical efficacy. In some embodiments, polyclonality refers to the T-cell repertoire diversity. In some embodiments, an increase in polyclonality can be indicative of treatment efficacy with regard to administration of the TILs produced by the methods of the present invention. In some embodiments, polyclonality is increased one-fold, two-fold, ten-fold, 100-fold, 500-fold, or 1000-fold as compared to TILs prepared using methods than those provide herein including for example, methods other than those embodied in Figure 27. In some embodiments, polyclonality is increased one-fold as compared to an untreated patient and/or as compared to a patient treated with TILs prepared using other methods than those provide herein including for example, methods other than those embodied

in Figure 27. In some embodiments, polyclonality is increased two-fold as compared to an untreated patient and/or as compared to a patient treated with TILs prepared using other methods than those provide herein including for example, methods other than those embodied in Figure 27. In some embodiments, polyclonality is increased ten-fold as compared to an untreated patient and/or as compared to a patient treated with TILs prepared using other methods than those provide herein including for example, methods other than those embodied in Figure 27. In some embodiments, polyclonality is increased 100-fold as compared to an untreated patient and/or as compared to a patient treated with TILs prepared using other methods than those provide herein including for example, methods other than those embodied in Figure 27. In some embodiments, polyclonality is increased 500-fold as compared to an untreated patient and/or as compared to a patient treated with TILs prepared using other methods than those provide herein including for example, methods other than those embodied in Figure 27. In some embodiments, polyclonality is increased 1000-fold as compared to an untreated patient and/or as compared to a patient treated with TILs prepared using other methods than those provide herein including for example, methods other than those embodied in Figure 27.

[00523] Measures of efficacy can include The disease control rate (DCR) measurements as well as overall response rate (ORR), as known in the art as well as described in the Examples provided herein, including Example 28.

#### 20           1.       **Methods of Treating Cancers and Other Diseases**

[00524] The compositions and methods described herein can be used in a method for treating diseases. In an embodiment, they are for use in treating hyperproliferative disorders. They may also be used in treating other disorders as described herein and in the following paragraphs.

25       [00525] In some embodiments, the hyperproliferative disorder is cancer. In some embodiments, the hyperproliferative disorder is a solid tumor cancer. In some embodiments, the solid tumor cancer is selected from the group consisting of melanoma, ovarian cancer, cervical cancer, non-small-cell lung cancer (NSCLC), lung cancer, bladder cancer, breast cancer, cancer caused by human papilloma virus, head and neck cancer (including head and neck squamous cell carcinoma (HNSCC)), renal cancer, and renal cell carcinoma. In some  
30       embodiments, the hyperproliferative disorder is a hematological malignancy. In some

embodiments, the solid tumor cancer is selected from the group consisting of chronic lymphocytic leukemia, acute lymphoblastic leukemia, diffuse large B cell lymphoma, non-Hodgkin's lymphoma, Hodgkin's lymphoma, follicular lymphoma, and mantle cell lymphoma.

5 [00526] In an embodiment, the invention includes a method of treating a cancer with a population of TILs, wherein a patient is pre-treated with non-myeloablative chemotherapy prior to an infusion of TILs according to the present disclosure. In an embodiment, the non-myeloablative chemotherapy is cyclophosphamide 60 mg/kg/d for 2 days (days 27 and 26 prior to TIL infusion) and fludarabine 25 mg/m<sup>2</sup>/d for 5 days (days 27 to 23 prior to TIL  
10 infusion). In an embodiment, after non-myeloablative chemotherapy and TIL infusion (at day 0) according to the present disclosure, the patient receives an intravenous infusion of IL-2 intravenously at 720,000 IU/kg every 8 hours to physiologic tolerance.

[00527] Efficacy of the compounds and combinations of compounds described herein in treating, preventing and/or managing the indicated diseases or disorders can be tested using  
15 various models known in the art, which provide guidance for treatment of human disease. For example, models for determining efficacy of treatments for ovarian cancer are described, *e.g.*, in Mullany, *et al.*, *Endocrinology* 2012, 153, 1585-92; and Fong, *et al.*, *J. Ovarian Res.* 2009, 2, 12. Models for determining efficacy of treatments for pancreatic cancer are described in Herreros-Villanueva, *et al.*, *World J. Gastroenterol.* 2012, 18, 1286-1294.  
20 Models for determining efficacy of treatments for breast cancer are described, *e.g.*, in Fantozzi, *Breast Cancer Res.* 2006, 8, 212. Models for determining efficacy of treatments for melanoma are described, *e.g.*, in Damsky, *et al.*, *Pigment Cell & Melanoma Res.* 2010, 23, 853-859. Models for determining efficacy of treatments for lung cancer are described, *e.g.*, in Meuwissen, *et al.*, *Genes & Development*, 2005, 19, 643-664. Models for determining  
25 efficacy of treatments for lung cancer are described, *e.g.*, in Kim, *Clin. Exp. Otorhinolaryngol.* 2009, 2, 55-60; and Sano, *Head Neck Oncol.* 2009, 1, 32.

[00528] In some embodiments, IFN-gamma (IFN- $\gamma$ ) is indicative of treatment efficacy for hyperproliferative disorder treatment. In some embodiments, IFN- $\gamma$  in the blood of subjects treated with TILs is indicative of active TILs. In some embodiments, a potency assay for  
30 IFN- $\gamma$  production is employed. IFN- $\gamma$  production is another measure of cytotoxic potential. IFN- $\gamma$  production can be measured by determining the levels of the cytokine IFN- $\gamma$  in the blood of a subject treated with TILs prepared by the methods of the present invention,

including those as described for example in Figure 27. In some embodiments, the TILs obtained by the present method provide for increased IFN- $\gamma$  in the blood of subjects treated with the TILs of the present method as compared subjects treated with TILs prepared using methods referred to as process 1C, as exemplified in Figure 83. In some embodiments, an increase in IFN- $\gamma$  is indicative of treatment efficacy in a patient treated with the TILs produced by the methods of the present invention. In some embodiments, IFN- $\gamma$  is increased one-fold, two-fold, three-fold, four-fold, or five-fold or more as compared to an untreated patient and/or as compared to a patient treated with TILs prepared using other methods than those provide herein including for example, methods other than those embodied in Figure 27.

5

10 In some embodiments, IFN- $\gamma$  secretion is increased one-fold as compared to an untreated patient and/or as compared to a patient treated with TILs prepared using other methods than those provide herein including for example, methods other than those embodied in Figure 27. In some embodiments, IFN- $\gamma$  secretion is increased two-fold as compared to an untreated patient and/or as compared to a patient treated with TILs prepared using other methods than those provide herein including for example, methods other than those embodied in Figure 27.

15

20 In some embodiments, IFN- $\gamma$  secretion is increased three-fold as compared to an untreated patient and/or as compared to a patient treated with TILs prepared using other methods than those provide herein including for example, methods other than those embodied in Figure 27. In some embodiments, IFN- $\gamma$  secretion is increased four-fold as compared to an untreated patient and/or as compared to a patient treated with TILs prepared using other methods than those provide herein including for example, methods other than those embodied in Figure 27.

25

30 In some embodiments, IFN- $\gamma$  is measured using a Quantikine ELISA kit. In some embodiments, IFN- $\gamma$  is measured using a Quantikine ELISA kit. In some embodiments, IFN- $\gamma$  is measured in TILs *ex vivo* from a patient treated with the TILs produced by the methods of the present invention. In some embodiments, IFN- $\gamma$  is measured in blood in a patient treated with the TILs produced by the methods of the present invention. In some embodiments, IFN- $\gamma$  is measured in serum in a patient treated with the TILs produced by the methods of the present invention.

[00529] In some embodiments, higher average IP-10 is indicative of treatment efficacy and/or increased clinical efficacy for hyperproliferative disorder treatment. In some embodiments, higher average IP-10 in the blood of subjects treated with TILs is indicative of active TILs. In some embodiments, the TILs obtained by the present method provide for higher average IP-10 in the blood of subjects treated with the TILs of the present method as compared subjects treated with TILs prepared using methods referred to as process 1C, as exemplified in Figure 83. IP-10 production can be measured by determining the levels of the IP-10 in the blood of a subject treated with TILs prepared by the methods of the present invention, including those as described for example in Figure 27. In some embodiments, higher average IP-10 is indicative of treatment efficacy in a patient treated with the TILs produced by the methods of the present invention. In some embodiments, higher average IP-10 correlates to an increase of one-fold, two-fold, three-fold, four-fold, or five-fold or more as compared to an untreated patient and/or as compared to a patient treated with TILs prepared using other methods than those provide herein including for example, methods other than those embodied in Figure 27. In some embodiments, higher average IP-10 correlates to an increase of one-fold as compared to an untreated patient and/or as compared to a patient treated with TILs prepared using other methods than those provide herein including for example, methods other than those embodied in Figure 27. In some embodiments, higher average IP-10 correlates to an increase of two-fold as compared to an untreated patient and/or as compared to a patient treated with TILs prepared using other methods than those provide herein including for example, methods other than those embodied in Figure 27. In some embodiments, higher average IP-10 correlates to an increase of three-fold as compared to an untreated patient and/or as compared to a patient treated with TILs prepared using other methods than those provide herein including for example, methods other than those embodied in Figure 27. In some embodiments, higher average IP-10 correlates to an increase of four-fold as compared to an untreated patient and/or as compared to a patient treated with TILs prepared using other methods than those provide herein including for example, methods other than those embodied in Figure 27. In some embodiments, higher average IP-10 correlates to an increase of five-fold as compared to an untreated patient and/or as compared to a patient treated with TILs prepared using other methods than those provide herein including for example, methods other than those embodied in Figure 27.

[00530] In some embodiments, higher average MCP-1 is indicative of treatment efficacy and/or increased clinical efficacy for hyperproliferative disorder treatment. In some embodiments, higher average MCP-1 in the blood of subjects treated with TILs is indicative of active TILs. In some embodiments, the TILs obtained by the present method provide for higher average MCP-1 in the blood of subjects treated with the TILs of the present method as compared subjects treated with TILs prepared using methods referred to as process 1C, as exemplified in Figure 83. MCP-1 production can be measured by determining the levels of the MCP-1 in the blood of a subject treated with TILs prepared by the methods of the present invention, including those as described for example in Figure 27. In some embodiments, higher average MCP-1 is indicative of treatment efficacy in a patient treated with the TILs produced by the methods of the present invention. In some embodiments, higher average MCP-1 correlates to an increase of one-fold, two-fold, three-fold, four-fold, or five-fold or more as compared to an untreated patient and/or as compared to a patient treated with TILs prepared using other methods than those provide herein including for example, methods other than those embodied in Figure 27. In some embodiments, higher average MCP-1 correlates to an increase of one-fold as compared to an untreated patient and/or as compared to a patient treated with TILs prepared using other methods than those provide herein including for example, methods other than those embodied in Figure 27. In some embodiments, higher average MCP-1 correlates to an increase of two-fold as compared to an untreated patient and/or as compared to a patient treated with TILs prepared using other methods than those provide herein including for example, methods other than those embodied in Figure 27. In some embodiments, higher average MCP-1 correlates to an increase of three-fold as compared to an untreated patient and/or as compared to a patient treated with TILs prepared using other methods than those provide herein including for example, methods other than those embodied in Figure 27. In some embodiments, higher average MCP-1 correlates to an increase of four-fold as compared to an untreated patient and/or as compared to a patient treated with TILs prepared using other methods than those provide herein including for example, methods other than those embodied in Figure 27. In some embodiments, higher average MCP-1 correlates to an increase of five-fold as compared to an untreated patient and/or as compared to a patient treated with TILs prepared using other methods than those provide herein including for example, methods other than those embodied in Figure 27.

[00531] In some embodiments, the TILs prepared by the methods of the present invention, including those as described for example in Figure 27, exhibit increased polyclonality as compared to TILs produced by other methods, including those not exemplified in Figure 27, such as for example, methods referred to as process 1C methods. In some embodiments, significantly improved polyclonality and/or increased polyclonality is indicative of treatment efficacy and/or increased clinical efficacy for cancer treatment. In some embodiments, polyclonality refers to the T-cell repertoire diversity. In some embodiments, an increase in polyclonality can be indicative of treatment efficacy with regard to administration of the TILs produced by the methods of the present invention. In some embodiments, polyclonality is increased one-fold, two-fold, ten-fold, 100-fold, 500-fold, or 1000-fold as compared to TILs prepared using methods than those provide herein including for example, methods other than those embodied in Figure 27. In some embodiments, polyclonality is increased one-fold as compared to an untreated patient and/or as compared to a patient treated with TILs prepared using other methods than those provide herein including for example, methods other than those embodied in Figure 27. In some embodiments, polyclonality is increased two-fold as compared to an untreated patient and/or as compared to a patient treated with TILs prepared using other methods than those provide herein including for example, methods other than those embodied in Figure 27. In some embodiments, polyclonality is increased ten-fold as compared to an untreated patient and/or as compared to a patient treated with TILs prepared using other methods than those provide herein including for example, methods other than those embodied in Figure 27. In some embodiments, polyclonality is increased 100-fold as compared to an untreated patient and/or as compared to a patient treated with TILs prepared using other methods than those provide herein including for example, methods other than those embodied in Figure 27. In some embodiments, polyclonality is increased 500-fold as compared to an untreated patient and/or as compared to a patient treated with TILs prepared using other methods than those provide herein including for example, methods other than those embodied in Figure 27. In some embodiments, polyclonality is increased 1000-fold as compared to an untreated patient and/or as compared to a patient treated with TILs prepared using other methods than those provide herein including for example, methods other than those embodied in Figure 27.

## 2. Methods of co-administration

[00532] In some embodiments, the TILs produced as described herein, including for example TILs derived from a method described in Steps A through F of Figure 27, can be administered in combination with one or more immune checkpoint regulators, such as the antibodies described below. For example, antibodies that target PD-1 and which can be co-administered with the TILs of the present invention include, *e.g.*, but are not limited to

5 nivolumab (BMS-936558, Bristol-Myers Squibb; Opdivo®), pembrolizumab (lambrolizumab, MK03475 or MK-3475, Merck; Keytruda®), humanized anti-PD-1 antibody JS001 (ShangHai JunShi), monoclonal anti-PD-1 antibody TSR-042 (Tesarro, Inc.),

10 Pidilizumab (anti-PD-1 mAb CT-011, Medivation), anti-PD-1 monoclonal Antibody BGB-A317 (BeiGene), and/or anti-PD-1 antibody SHR-1210 (ShangHai HengRui), human monoclonal antibody REGN2810 (Regeneron), human monoclonal antibody MDX-1106 (Bristol-Myers Squibb), and/or humanized anti-PD-1 IgG4 antibody PDR001 (Novartis). In some embodiments, the PD-1 antibody is from clone: RMP1-14 (rat IgG) - BioXcell cat# BP0146. Other suitable antibodies suitable for use in co-administration methods with TILs

15 produced according to Steps A through F as described herein are anti-PD-1 antibodies disclosed in U.S. Patent No. 8,008,449, herein incorporated by reference. In some embodiments, the antibody or antigen-binding portion thereof binds specifically to PD-L1 and inhibits its interaction with PD-1, thereby increasing immune activity. Any antibodies known in the art which bind to PD-L1 and disrupt the interaction between the PD-1 and PD-

20 L1, and stimulates an anti-tumor immune response, are suitable for use in co-administration methods with TILs produced according to Steps A through F as described herein. For example, antibodies that target PD-L1 and are in clinical trials, include BMS-936559 (Bristol-Myers Squibb) and MPDL3280A (Genentech). Other suitable antibodies that target PD-L1 are disclosed in U.S. Patent No. 7,943,743, herein incorporated by reference. It will be

25 understood by one of ordinary skill that any antibody which binds to PD-1 or PD-L1, disrupts the PD-1/PD-L1 interaction, and stimulates an anti-tumor immune response, are suitable for use in co-administration methods with TILs produced according to Steps A through F as described herein. In some embodiments, the subject administered the combination of TILs produced according to Steps A through F is co administered with a and anti-PD-1 antibody

30 when the patient has a cancer type that is refractory to administration of the anti-PD-1 antibody alone. In some embodiments, the patient is administered TILs in combination with and anti-PD-1 when the patient has refractory melanoma. In some embodiments, the patient

is administered TILs in combination with and anti-PD-1 when the patient has non-small-cell lung carcinoma (NSCLC).

### 3. Optional Lymphodepletion Preconditioning of Patients

[00533] In an embodiment, the invention includes a method of treating a cancer with a population of TILs, wherein a patient is pre-treated with non-myeloablative chemotherapy prior to an infusion of TILs according to the present disclosure. In an embodiment, the invention includes a population of TILs for use in the treatment of cancer in a patient which has been pre-treated with non-myeloablative chemotherapy. In an embodiment, the population of TILs is for administration by infusion. In an embodiment, the non-myeloablative chemotherapy is cyclophosphamide 60 mg/kg/d for 2 days (days 27 and 26 prior to TIL infusion) and fludarabine 25 mg/m<sup>2</sup>/d for 5 days (days 27 to 23 prior to TIL infusion). In an embodiment, after non-myeloablative chemotherapy and TIL infusion (at day 0) according to the present disclosure, the patient receives an intravenous infusion of IL-2 (aldesleukin, commercially available as PROLEUKIN) intravenously at 720,000 IU/kg every 8 hours to physiologic tolerance. In certain embodiments, the population of TILs is for use in treating cancer in combination with IL-2, wherein the IL-2 is administered after the population of TILs.

[00534] Experimental findings indicate that lymphodepletion prior to adoptive transfer of tumor-specific T lymphocytes plays a key role in enhancing treatment efficacy by eliminating regulatory T cells and competing elements of the immune system ('cytokine sinks'). Accordingly, some embodiments of the invention utilize a lymphodepletion step (sometimes also referred to as "immunosuppressive conditioning") on the patient prior to the introduction of the TILs of the invention.

[00535] In general, lymphodepletion is achieved using administration of fludarabine or cyclophosphamide (the active form being referred to as mafosfamide) and combinations thereof. Such methods are described in Gassner, *et al.*, *Cancer Immunol. Immunother.* **2011**, 60, 75–85, Muranski, *et al.*, *Nat. Clin. Pract. Oncol.*, **2006**, 3, 668–681, Dudley, *et al.*, *J. Clin. Oncol.* **2008**, 26, 5233-5239, and Dudley, *et al.*, *J. Clin. Oncol.* **2005**, 23, 2346–2357, all of which are incorporated by reference herein in their entireties.

[00536] In some embodiments, the fludarabine is administered at a concentration of 0.5 µg/mL -10 µg/mL fludarabine. In some embodiments, the fludarabine is administered at a

concentration of 1  $\mu\text{g/mL}$  fludarabine. In some embodiments, the fludarabine treatment is administered for 1 day, 2 days, 3 days, 4 days, 5 days, 6 days, or 7 days or more. In some embodiments, the fludarabine is administered at a dosage of 10 mg/kg/day, 15 mg/kg/day, 20 mg/kg/day, 25 mg/kg/day, 30 mg/kg/day, 35 mg/kg/day, 40 mg/kg/day, or 45 mg/kg/day.

5 In some embodiments, the fludarabine treatment is administered for 2-7 days at 35 mg/kg/day. In some embodiments, the fludarabine treatment is administered for 4-5 days at 35 mg/kg/day. In some embodiments, the fludarabine treatment is administered for 4-5 days at 25 mg/kg/day.

[00537] In some embodiments, the mafosfamide, the active form of cyclophosphamide, is  
10 obtained at a concentration of 0.5  $\mu\text{g/mL}$  -10  $\mu\text{g/mL}$  by administration of cyclophosphamide. In some embodiments, mafosfamide, the active form of cyclophosphamide, is obtained at a concentration of 1  $\mu\text{g/mL}$  by administration of cyclophosphamide. In some embodiments, the cyclophosphamide treatment is administered for 1 day, 2 days, 3 days, 4 days, 5 days, 6 days, or 7 days or more. In some embodiments, the cyclophosphamide is administered at a dosage  
15 of 100  $\text{mg/m}^2/\text{day}$ , 150  $\text{mg/m}^2/\text{day}$ , 175  $\text{mg/m}^2/\text{day}$ , 200  $\text{mg/m}^2/\text{day}$ , 225  $\text{mg/m}^2/\text{day}$ , 250  $\text{mg/m}^2/\text{day}$ , 275  $\text{mg/m}^2/\text{day}$ , or 300  $\text{mg/m}^2/\text{day}$ . In some embodiments, the cyclophosphamide is administered intravenously (*i.e.*, i.v.) In some embodiments, the cyclophosphamide treatment is administered for 2-7 days at 35 mg/kg/day. In some  
20 250  $\text{mg/m}^2/\text{day}$  i.v. In some embodiments, the cyclophosphamide treatment is administered for 4 days at 250  $\text{mg/m}^2/\text{day}$  i.v.

[00538] In some embodiments, lymphodepletion is performed by administering the fludarabine and the cyclophosphamide together to a patient. In some embodiments, fludarabine is administered at 25  $\text{mg/m}^2/\text{day}$  i.v. and cyclophosphamide is administered at  
25 250  $\text{mg/m}^2/\text{day}$  i.v. over 4 days.

[00539] In an embodiment, the lymphodepletion is performed by administration of cyclophosphamide at a dose of 60  $\text{mg/m}^2/\text{day}$  for two days followed by administration of fludarabine at a dose of 25  $\text{mg/m}^2/\text{day}$  for five days.

#### 4. IL-2 Regimens

30 [00540] In an embodiment, the IL-2 regimen comprises a high-dose IL-2 regimen, wherein the high-dose IL-2 regimen comprises aldesleukin, or a biosimilar or variant thereof,

administered intravenously starting on the day after administering a therapeutically effective portion of the therapeutic population of TILs, wherein the aldesleukin or a biosimilar or variant thereof is administered at a dose of 0.037 mg/kg or 0.044 mg/kg IU/kg (patient body mass) using 15-minute bolus intravenous infusions every eight hours until tolerance, for a maximum of 14 doses. Following 9 days of rest, this schedule may be repeated for another 14 doses, for a maximum of 28 doses in total.

[00541] In an embodiment, the IL-2 regimen comprises a decrescendo IL-2 regimen. Decrescendo IL-2 regimens have been described in O'Day, *et al.*, *J. Clin. Oncol.* **1999**, *17*, 2752-61 and Eton, *et al.*, *Cancer* **2000**, *88*, 1703-9, the disclosures of which are incorporated herein by reference. In an embodiment, a decrescendo IL-2 regimen comprises  $18 \times 10^6$  IU/m<sup>2</sup> administered intravenously over 6 hours, followed by  $18 \times 10^6$  IU/m<sup>2</sup> administered intravenously over 12 hours, followed by  $18 \times 10^6$  IU/m<sup>2</sup> administered intravenously over 24 hrs, followed by  $4.5 \times 10^6$  IU/m<sup>2</sup> administered intravenously over 72 hours. This treatment cycle may be repeated every 28 days for a maximum of four cycles. In an embodiment, a decrescendo IL-2 regimen comprises 18,000,000 IU/m<sup>2</sup> on day 1, 9,000,000 IU/m<sup>2</sup> on day 2, and 4,500,000 IU/m<sup>2</sup> on days 3 and 4.

[00542] In an embodiment, the IL-2 regimen comprises administration of pegylated IL-2 every 1, 2, 4, 6, 7, 14 or 21 days at a dose of 0.10 mg/day to 50 mg/day.

## 5. Adoptive Cell Transfer

[00543] Adoptive cell transfer (ACT) is a very effective form of immunotherapy and involves the transfer of immune cells with antitumor activity into cancer patients. ACT is a treatment approach that involves the identification, *in vitro*, of lymphocytes with antitumor activity, the *in vitro* expansion of these cells to large numbers and their infusion into the cancer-bearing host. Lymphocytes used for adoptive transfer can be derived from the stroma of resected tumors (tumor infiltrating lymphocytes or TILs). TILs for ACT can be prepared as described herein. In some embodiments, the TILs are prepared, for example, according to a method as described in Figure 27. They can also be derived or from blood if they are genetically engineered to express antitumor T-cell receptors (TCRs) or chimeric antigen receptors (CARs), enriched with mixed lymphocyte tumor cell cultures (MLTCs), or cloned using autologous antigen presenting cells and tumor derived peptides. ACT in which the lymphocytes originate from the cancer-bearing host to be infused is termed autologous ACT.

U.S. Publication No. 2011/0052530 relates to a method for performing adoptive cell therapy to promote cancer regression, primarily for treatment of patients suffering from metastatic melanoma, which is incorporated by reference in its entirety for these methods. In some embodiments, TILs can be administered as described herein. In some embodiments, TILs can be administered in a single dose. Such administration may be by injection, *e.g.*, intravenous injection. In some embodiments, TILs and/or cytotoxic lymphocytes may be administered in multiple doses. Dosing may be once, twice, three times, four times, five times, six times, or more than six times per year. Dosing may be once a month, once every two weeks, once a week, or once every other day. Administration of TILs and/or cytotoxic lymphocytes may continue as long as necessary.

#### 6. Exemplary Treatment Embodiments

**[00544]** In some embodiments, the present disclosure provides a method of treating a cancer with a population of tumor infiltrating lymphocytes (TILs) comprising the steps of (a) obtaining a first population of TILs from a tumor resected from a patient; (b) performing an initial expansion of the first population of TILs in a first cell culture medium to obtain a second population of TILs, wherein the second population of TILs is at least 5-fold greater in number than the first population of TILs, and wherein the first cell culture medium comprises IL-2; (c) performing a rapid expansion of the second population of TILs using a population of myeloid artificial antigen presenting cells (myeloid aAPCs) in a second cell culture medium to obtain a third population of TILs, wherein the third population of TILs is at least 50-fold greater in number than the second population of TILs after 7 days from the start of the rapid expansion; and wherein the second cell culture medium comprises IL-2 and OKT-3; (d) administering a therapeutically effective portion of the third population of TILs to a patient with the cancer. In some embodiments, the present disclosure a population of tumor infiltrating lymphocytes (TILs) for use in treating cancer, wherein the population of TILs are obtainable by a method comprising the steps of (b) performing an initial expansion of a first population of TILs obtained from a tumor resected from a patient in a first cell culture medium to obtain a second population of TILs, wherein the second population of TILs is at least 5-fold greater in number than the first population of TILs, and wherein the first cell culture medium comprises IL-2; (c) performing a rapid expansion of the second population of TILs using a population of myeloid artificial antigen presenting cells (myeloid aAPCs) in a second cell culture medium to obtain a third population of TILs, wherein the third population

of TILs is at least 50-fold greater in number than the second population of TILs after 7 days from the start of the rapid expansion; and wherein the second cell culture medium comprises IL-2 and OKT-3; (d) administering a therapeutically effective portion of the third population of TILs to a patient with the cancer. In some embodiments, the method comprises a first step

5 (a) of obtaining the first population of TILs from a tumor resected from a patient. In some embodiments, the IL-2 is present at an initial concentration of about 3000 IU/mL and OKT-3 antibody is present at an initial concentration of about 30 ng/mL in the second cell culture medium. In some embodiments, first expansion is performed over a period not greater than

10 container. In some embodiments, the second expansion is performed using a gas permeable container. In some embodiments, the ratio of the second population of TILs to the population of aAPCs in the rapid expansion is between 1 to 80 and 1 to 400. In some embodiments, the ratio of the second population of TILs to the population of aAPCs in the rapid expansion is about 1 to 300. In some embodiments, the cancer for treatment is selected from the group

15 consisting of melanoma, ovarian cancer, cervical cancer, non-small-cell lung cancer (NSCLC), lung cancer, bladder cancer, breast cancer, cancer caused by human papilloma virus, head and neck cancer (including head and neck squamous cell carcinoma (HNSCC)), renal cancer, and renal cell carcinoma. In some embodiments, the cancer for treatment is selected from the group consisting of melanoma, ovarian cancer, and cervical cancer. In

20 some embodiments, the cancer for treatment is melanoma. In some embodiments, the cancer for treatment is ovarian cancer. In some embodiments, the cancer for treatment is cervical cancer. In some embodiments, the method of treating cancer further comprises the step of treating the patient with a non-myeloablative lymphodepletion regimen prior to administering the third population of TILs to the patient. In some embodiments, the non-myeloablative

25 lymphodepletion regimen comprises the steps of administration of cyclophosphamide at a dose of 60 mg/m<sup>2</sup>/day for two days followed by administration of fludarabine at a dose of 25 mg/m<sup>2</sup>/day for five days. In some embodiments, the high dose IL-2 regimen comprises 600,000 or 720,000 IU/kg of aldesleukin, or a biosimilar or variant thereof, administered as a 15-minute bolus intravenous infusion every eight hours until tolerance.

30

## V. Exemplary Embodiments

[00545] In some embodiments, the present invention provides a method for treating a subject with cancer, the method comprising administering expanded tumor infiltrating lymphocytes (TILs) comprising:

- 5 (a) obtaining a first population of TILs from a tumor resected from a subject by processing a tumor sample obtained from the patient into multiple tumor fragments;
- (b) adding the tumor fragments into a closed system;
- 10 (c) performing a first expansion by culturing the first population of TILs in a cell culture medium comprising IL-2 to produce a second population of TILs, wherein the first expansion is performed in a closed container providing a first gas-permeable surface area, wherein the first expansion is performed for about 11 days to obtain the second population of TILs, wherein the second population of TILs is at least 50-fold greater in number than the first population of TILs, and wherein the transition from step (b) to step (c) occurs without opening the system;
- 15 (d) performing a second expansion by supplementing the cell culture medium of the second population of TILs with additional IL-2, OKT-3, and antigen presenting cells (APCs), to produce a third population of TILs, wherein the second expansion is performed for about 11 days to obtain the third population of TILs, wherein the third population of TILs is a therapeutic population of TILs, wherein the second expansion is performed in a closed container providing a second gas-permeable surface area, and wherein the transition from step (c) to step (d) occurs without opening the system;
- 20 (e) harvesting the therapeutic population of TILs obtained from step (d), wherein the transition from step (d) to step (e) occurs without opening the system; and
- 25 (f) transferring the harvested TIL population from step (e) to an infusion bag, wherein the transfer from step (e) to (f) occurs without opening the system;
- (g) cryopreserving the infusion bag comprising the harvested TIL population from step (f) using a cryopreservation process; and
- 30 (h) administering a therapeutically effective dosage of the third population of TILs from the infusion bag in step (g) to the patient.

[00546] In some embodiment, the cryopreservation process comprises cryopreservation in a media comprising DMSO. In some embodiments, the cryopreservation

media comprises 7% to 10% DMSO. In some embodiments, the cryopreservation medium in CS10.

5 [00547] In some embodiments, the therapeutic population of TILs harvested in step (e) comprises sufficient TILs for administering a therapeutically effective dosage of the TILs in step (h).

[00548] In some embodiments, the number of TILs sufficient for administering a therapeutically effective dosage in step (h) is from about  $2.3 \times 10^{10}$  to about  $13.7 \times 10^{10}$ .

[00549] In some embodiments, the antigen presenting cells (APCs) are PBMCs.

10 [00550] In some embodiments, the PBMCs are added to the cell culture on any of days 9 through 11 in step (d).

[00551] In some embodiments, prior to administering a therapeutically effective dosage of TIL cells in step (h), a non-myeloablative lymphodepletion regimen has been administered to the patient.

15 [00552] In some embodiments, the non-myeloablative lymphodepletion regimen comprises the steps of administration of cyclophosphamide at a dose of  $60 \text{ mg/m}^2/\text{day}$  for two days followed by administration of fludarabine at a dose of  $25 \text{ mg/m}^2/\text{day}$  for five days.

[00553] In some embodiments, the method further comprises the step of treating the patient with a high-dose IL-2 regimen starting on the day after administration of the TIL cells to the patient in step (h).

20 [00554] In some embodiments, the high-dose IL-2 regimen comprises 600,000 or 720,000 IU/kg administered as a 15-minute bolus intravenous infusion every eight hours until tolerance.

25 [00555] In some embodiments, the third population of TILs in step (d) provides for increased efficacy, increased interferon-gamma (IFN- $\gamma$ ) production, increased polyclonality, increased average IP-10, and/or increased average MCP-1 when administered to a subject. In some embodiments, the increase in IFN- $\gamma$ , increased average IP-10, and/or increased average MCP-1 is measured in the blood of the subject treated with the TILs.

30 [00556] In some embodiments, the cancer is selected from the group consisting of melanoma, ovarian cancer, cervical cancer, non-small-cell lung cancer (NSCLC), lung cancer, bladder cancer, breast cancer, cancer caused by human papilloma virus, head and

neck cancer (including head and neck squamous cell carcinoma (HNSCC)), renal cancer, and renal cell carcinoma. In some embodiments, the cancer is selected from the group consisting of melanoma, HNSCC, cervical cancers, and NSCLC. In some embodiments, the cancer is melanoma. In some embodiments, the cancer is HNSCC. In some embodiments, the cancer is a cervical cancer. In some embodiments, the cancer is NSCLC.

**[00557]** In an embodiment, the invention provides a method for expanding tumor infiltrating lymphocytes (TILs).

**[00558]** The present invention provides a method for expanding tumor infiltrating lymphocytes (TILs) comprising: (a) obtaining a tumor sample from a patient, wherein said tumor sample comprises a first population of TILs; (b) processing said tumor sample into multiple tumor fragments; (c) adding said tumor fragments into a closed container; (d) performing an initial expansion of said first population of TILs in a first cell culture medium to obtain a second population of TILs, wherein said first cell culture medium comprises IL-2, wherein said initial expansion is performed in said closed container providing at least 100 cm<sup>2</sup> of gas-permeable surface area, wherein said initial expansion is performed within a first period of about 7-14 days to obtain a second population of TILs, wherein said second population of TILs is at least 50-fold greater in number than said first population of TILs, and wherein the transition from step (c) to step (d) occurs without opening the system; (e) expanding said second population of TILs in a second cell culture medium, wherein said second cell culture medium comprises IL-2, OKT-3, and peripheral blood mononuclear cells (PBMCs, also known as mononuclear cells (MNCs)), wherein said expansion is performed within a second period of about 7-14 days to obtain a third population of TILs, wherein said third population of TILs exhibits an increased subpopulation of effector T cells and/or central memory T cells relative to the second population of TILs, wherein said expansion is performed in a closed container providing at least 500 cm<sup>2</sup> of gas-permeable surface area, and wherein the transition from step (d) to step (e) occurs without opening the system; (f) harvesting said third population of TILs obtained from step (e), wherein the transition from step (e) to step (f) occurs without opening the system; and (g) transferring said harvested TIL population from step (f) to an infusion bag, wherein said transfer from step (f) to (g) occurs without opening the system. In some embodiments, the method is an *in vitro* or an *ex vivo* method.

- 5 [00559] In some embodiments, the method further comprises harvesting in step (f) via a cell processing system, such as the LOVO system manufactured by Fresenius Kabi. The term “LOVO cell processing system” also refers to any instrument or device manufactured by any vendor that can pump a solution comprising cells through a membrane or filter such as a spinning membrane or spinning filter in a sterile and/or closed system environment, allowing for continuous flow and cell processing to remove supernatant or cell culture media without pelletization. In some cases, the cell processing system can perform cell separation, washing, fluid-exchange, concentration, and/or other cell processing steps in a closed, sterile system.
- 10 [00560] In some embodiments, the closed container is selected from the group consisting of a G-container and a Xuri cellbag.
- [00561] In some embodiments, the infusion bag in step (g) is a HypoThermosol-containing infusion bag.
- [00562] In some embodiments, the first period in step (d) and said second period in step (e) are each individually performed within a period of 10 days, 11 days, or 12 days.
- 15 [00563] In some embodiments, the first period in step (d) and said second period in step (e) are each individually performed within a period of 11 days.
- [00564] In some embodiments, steps (a) through (g) are performed within a period of about 25 days to about 30 days.
- [00565] In some embodiments, steps (a) through (g) are performed within a period of about 20 20 days to about 25 days.
- [00566] In some embodiments, steps (a) through (g) are performed within a period of about 20 days to about 22 days.
- [00567] In some embodiments, steps (a) through (g) are performed in 22 days or less.
- 25 [00568] In some embodiments, steps (c) through (f) are performed in a single container, wherein performing steps (c) through (f) in a single container results in an increase in TIL yield per resected tumor as compared to performing steps (c) through (f) in more than one container.
- [00569] In some embodiments, the PBMCs are added to the TILs during the second period in step (e) without opening the system.

[00570] In some embodiments, the effector T cells and/or central memory T cells obtained from said third population of TILs exhibit one or more characteristics selected from the group consisting of expressing CD27+, expressing CD28+, longer telomeres, increased CD57 expression, and decreased CD56 expression relative to effector T cells and/or central memory T cells obtained from said second population of cells.

[00571] In some embodiments, the effector T cells and/or central memory T cells obtained from said third population of TILs exhibit increased CD57 expression and decreased CD56 expression relative to effector T cells and/or central memory T cells obtained from said second population of cells.

[00572] In some embodiments, the risk of microbial contamination is reduced as compared to an open system.

[00573] In some embodiments, the TILs from step (g) are infused into a patient.

[00574] The present invention also provides a method of treating cancer in a patient with a population of tumor infiltrating lymphocytes (TILs) comprising the steps of: (a) obtaining a tumor sample from a patient, wherein said tumor sample comprises a first population of TILs; (b) processing said tumor sample into multiple tumor fragments; (c) adding said tumor fragments into a closed container; (d) performing an initial expansion of said first population of TILs in a first cell culture medium to obtain a second population of TILs, wherein said first cell culture medium comprises IL-2, wherein said initial expansion is performed in said closed container providing at least 100 cm<sup>2</sup> of gas-permeable surface area, wherein said initial expansion is performed within a first period of about 7-14 days to obtain a second population of TILs, wherein said second population of TILs is at least 50-fold greater in number than said first population of TILs, and wherein the transition from step (c) to step (d) occurs without opening the system; (e) expanding said second population of TILs in a second cell culture medium, wherein said second cell culture medium comprises IL-2, OKT-3, and peripheral blood mononuclear cells (PBMCs), wherein said expansion is performed within a second period of about 7-14 days to obtain a third population of TILs, wherein said third population of TILs exhibits an increased subpopulation of effector T cells and/or central memory T cells relative to the second population of TILs, wherein said expansion is performed in a closed container providing at least 500 cm<sup>2</sup> of gas-permeable surface area, and wherein the transition from step (d) to step (e) occurs without opening the system; (f) harvesting said third population of TILs obtained from step (e), wherein the transition from

step (e) to step (f) occurs without opening the system; (g) transferring said harvested TIL population from step (f) to an infusion bag, wherein said transfer from step (f) to (g) occurs without opening the system; and (h) administering a therapeutically effective amount of TIL cells from said infusion bag in step (g) to said patient.

- 5 [00575] In some embodiments, the present invention also comprises a population of tumor infiltrating lymphocytes (TILs) for use in treating cancer, wherein the population of TILs is obtainable from a method comprising the steps of: (b) processing a tumor sample obtained from a patient wherein said tumour sample comprises a first population of TILs into multiple tumor fragments; (c) adding said tumor fragments into a closed container; (d) performing an
- 10 initial expansion of said first population of TILs in a first cell culture medium to obtain a second population of TILs, wherein said first cell culture medium comprises IL-2, wherein said initial expansion is performed in said closed container providing at least 100 cm<sup>2</sup> of gas-permeable surface area, wherein said initial expansion is performed within a first period of about 7-14 days to obtain a second population of TILs, wherein said second population of
- 15 TILs is at least 50-fold greater in number than said first population of TILs, and wherein the transition from step (c) to step (d) occurs without opening the system; (e) expanding said second population of TILs in a second cell culture medium, wherein said second cell culture medium comprises IL-2, OKT-3, and peripheral blood mononuclear cells (PBMCs), wherein said expansion is performed within a second period of about 7-14 days to obtain a third
- 20 population of TILs, wherein said third population of TILs exhibits an increased subpopulation of effector T cells and/or central memory T cells relative to the second population of TILs, wherein said expansion is performed in a closed container providing at least 500 cm<sup>2</sup> of gas-permeable surface area, and wherein the transition from step (d) to step (e) occurs without opening the system; (f) harvesting said third population of TILs obtained
- 25 from step (e), wherein the transition from step (e) to step (f) occurs without opening the system; (g) transferring said harvested TIL population from step (f) to an infusion bag, wherein said transfer from step (f) to (g) occurs without opening the system. In some embodiments, the method comprises a first step (a) obtaining the tumor sample from a patient, wherein said tumor sample comprises the first population of TILs. In some
- 30 embodiments, the population of TILs is for administration from said infusion bag in step (g) in a therapeutically effective amount.

[00576] In some embodiments, prior to administering a therapeutically effective amount of TIL cells in step (h), a non-myeloablative lymphodepletion regimen has been administered to said patient. In some embodiments, the populations of TILs is for administration to a patient who has undergone a non-myeloablative lymphodepletion regimen.

- 5 [00577] In some embodiments, the non-myeloablative lymphodepletion regimen comprises the steps of administration of cyclophosphamide at a dose of 60 mg/m<sup>2</sup>/day for two days followed by administration of fludarabine at a dose of 25 mg/m<sup>2</sup>/day for five days.

[00578] In some embodiments, the method further comprises the step of treating said patient with a high-dose IL-2 regimen starting on the day after administration of said TIL cells to  
10 said patient in step (h). In some embodiments, the populations of TILs is for administration prior to a high-dose IL-2 regimen. In some embodiments, the population of TILs is for administration one day before the start of the high-dose IL-2 regimen.

[00579] In some embodiments, the high-dose IL-2 regimen comprises 600,000 or 720,000 IU/kg administered as a 15-minute bolus intravenous infusion every eight hours until  
15 tolerance.

[00580] In some embodiments, the effector T cells and/or central memory T cells obtained from said third population of TILs exhibit one or more characteristics selected from the group consisting of expressing CD27+, expressing CD28+, longer telomeres, increased CD57 expression, and decreased CD56 expression relative to effector T cells and/or central memory  
20 T cells obtained from said second population of cells.

[00581] In some embodiments, the effector T cells and/or central memory T cells obtained from said third population of TILs exhibit increased CD57 expression and decreased CD56 expression relative to effector T cells and/or central memory T cells obtained from said second population of cells.

25 [00582] The present invention also provides a method for expanding tumor infiltrating lymphocytes (TILs) comprising the steps of (a) adding processed tumor fragments into a closed system; (b) performing in a first expansion of said first population of TILs in a first cell culture medium to obtain a second population of TILs, wherein said first cell culture medium comprises IL-2, wherein said first expansion is performed in a closed container  
30 providing a first gas-permeable surface area, wherein said first expansion is performed within a first period of about 3-14 days to obtain a second population of TILs, wherein said second

population of TILs is at least 50-fold greater in number than said first population of TILs, and wherein the transition from step (a) to step (b) occurs without opening the system; (c) expanding said second population of TILs in a second cell culture medium, wherein said second cell culture medium comprises IL-2, OKT-3, and antigen-presenting cells, wherein  
5 said expansion is performed within a second period of about 7-14 days to obtain a third population of TILs, wherein said third population of TILs exhibits an increased subpopulation of effector T cells and/or central memory T cells relative to the second population of TILs, wherein said expansion is performed in a closed container providing a second gas-permeable surface area, and wherein the transition from step (b) to step (c) occurs  
10 without opening the system; (d) harvesting said third population of TILs obtained from step (c), wherein the transition from step (c) to step (d) occurs without opening the system; and (e) transferring said harvested TIL population from step (d) to an infusion bag, wherein said transfer from step (d) to (e) occurs without opening the system.

**[00583]** In some embodiments, the method further comprises the step of cryopreserving the  
15 infusion bag comprising the harvested TIL population using a cryopreservation process. In some embodiments, the cryopreservation process is performed using a 1:1 ratio of harvested TIL population to CS10 media.

**[00584]** In some embodiments, the antigen-presenting cells are peripheral blood  
mononuclear cells (PBMCs). In some embodiments, the antigen-presenting cells are artificial  
20 antigen-presenting cells.

**[00585]** In some embodiments, the harvesting in step (d) is performed using a LOVO cell processing system.

**[00586]** In some embodiments, the multiple fragments comprise about 50 fragments, wherein each fragment has a volume of about  $27 \text{ mm}^3$ . In some embodiments, the multiple  
25 fragments comprise about 30 to about 60 fragments with a total volume of about  $1300 \text{ mm}^3$  to about  $1500 \text{ mm}^3$ . In some embodiments, the multiple fragments comprise about 50 fragments with a total volume of about  $1350 \text{ mm}^3$ . In some embodiments, the multiple fragments comprise about 50 fragments with a total mass of about 1 gram to about 1.5 grams.

**[00587]** In some embodiments, the second cell culture medium is provided in a container  
30 selected from the group consisting of a G-container and a Xuri cellbag.

[00588] In some embodiments, the infusion bag in step (e) is a HypoThermosol-containing infusion bag.

[00589] In some embodiments, the first period in step (b) and said second period in step (c) are each individually performed within a period of 10 days, 11 days, or 12 days. In some  
5       embodiments, the first period in step (b) and said second period in step (c) are each individually performed within a period of 11 days.

[00590] In some embodiments, the steps (a) through (e) are performed within a period of about 25 days to about 30 days. In some embodiments, the steps (a) through (e) are performed within a period of about 20 days to about 25 days. In some embodiments, the  
10       steps (a) through (e) are performed within a period of about 20 days to about 22 days. In some embodiments, the steps (a) through (e) are performed in 22 days or less. In some embodiments, the steps (a) through (e) and cryopreservation are performed in 22 days or less.

[00591] In some embodiments, the steps (b) through (e) are performed in a single closed system, wherein performing steps (b) through (e) in a single container results in an increase in  
15       TIL yield per resected tumor as compared to performing steps (b) through (e) in more than one container.

[00592] In some embodiments, the antigen-presenting cells are added to the TILs during the second period in step (c) without opening the system.

[00593] In some embodiments, the effector T cells and/or central memory T cells obtained  
20       from said third population of TILs exhibit one or more characteristics selected from the group consisting of expressing CD27+, expressing CD28+, longer telomeres, increased CD57 expression, and decreased CD56 expression relative to effector T cells and/or central memory T cells obtained from said second population of cells.

[00594] In some embodiments, the effector T cells and/or central memory T cells obtained  
25       from said third population of TILs exhibit increased CD57 expression and decreased CD56 expression relative to effector T cells and/or central memory T cells obtained from said second population of cells.

[00595] In some embodiments, the risk of microbial contamination is reduced as compared to an open system.

30       [00596] In some embodiments, the TILs from step (e) are infused into a patient.

[00597] In some embodiments, the closed container comprises a single bioreactor. In some embodiments, the closed container comprises a G-REX-10. In some embodiments, the closed container comprises a G-REX-100. In some embodiments, the closed container comprises a G-Rex 500. In some embodiments, the closed container comprises a Xuri or Wave bioreactor gas permeable bag.

[00598] In some embodiments, the present disclosure provides a method for expanding tumor infiltrating lymphocytes (TILs) into a therapeutic population of TILs comprising:

- (b) adding tumor fragments into a closed system wherein the tumour fragments comprise a first population of TILs;
- 10 (c) performing a first expansion by culturing the first population of TILs in a cell culture medium comprising IL-2 to produce a second population of TILs, wherein the first expansion is performed in a closed container providing a first gas-permeable surface area, wherein the first expansion is performed for about 3-14 days to obtain the second population of TILs, wherein the second population of TILs is at least 50-fold greater in number than the first population of TILs, and  
15 wherein the transition from step (b) to step (c) occurs without opening the system;
- (d) performing a second expansion by supplementing the cell culture medium of the second population of TILs with additional IL-2, OKT-3, and antigen presenting cells (APCs), to produce a third population of TILs, wherein the second expansion  
20 is performed for about 7-14 days to obtain the third population of TILs, wherein the third population of TILs is a therapeutic population of TILs which comprises an increased subpopulation of effector T cells and/or central memory T cells relative to the second population of TILs, wherein the second expansion is performed in a closed container providing a second gas-permeable surface area, and wherein the transition from step (c) to step (d) occurs without opening the  
25 system;
- (e) harvesting the therapeutic population of TILs obtained from step (d), wherein the transition from step (d) to step (e) occurs without opening the system; and
- (f) transferring the harvested TIL population from step (e) to an infusion bag,  
30 wherein the transfer from step (e) to (f) occurs without opening the system.

[00599] In some embodiments, the method also comprises as a first step:

(a) obtaining a first population of TILs from a tumor resected from a patient by processing a tumor sample obtained from the patient into multiple tumor fragments.

[00600] In an embodiment, the method is an *in vitro* or an *ex vivo* method.

[00601] In some embodiments, the present disclosure provides a method for expanding  
5 tumor infiltrating lymphocytes (TILs) into a therapeutic population of TILs comprising:

- (a) obtaining a first population of TILs from a tumor resected from a patient by processing a tumor sample obtained from the patient into multiple tumor fragments;
- (b) adding the tumor fragments into a closed system;
- 10 (c) performing a first expansion by culturing the first population of TILs in a cell culture medium comprising IL-2 to produce a second population of TILs, wherein the first expansion is performed in a closed container providing a first gas-permeable surface area, wherein the first expansion is performed for about 3-14 days to obtain the second population of TILs, wherein the second population of  
15 TILs is at least 50-fold greater in number than the first population of TILs, and wherein the transition from step (b) to step (c) occurs without opening the system;
- (d) performing a second expansion by supplementing the cell culture medium of the second population of TILs with additional IL-2, OKT-3, and antigen presenting cells (APCs), to produce a third population of TILs, wherein the second expansion  
20 is performed for about 7-14 days to obtain the third population of TILs, wherein the third population of TILs is a therapeutic population of TILs which comprises an increased subpopulation of effector T cells and/or central memory T cells relative to the second population of TILs, wherein the second expansion is performed in a closed container providing a second gas-permeable surface area,  
25 and wherein the transition from step (c) to step (d) occurs without opening the system;
- (e) harvesting the therapeutic population of TILs obtained from step (d), wherein the transition from step (d) to step (e) occurs without opening the system; and
- (f) transferring the harvested TIL population from step (e) to an infusion bag,  
30 wherein the transfer from step (e) to (f) occurs without opening the system.

[00602] In an embodiment, the method is an *in vitro* or an *ex vivo* method.

- [00603] In some embodiments, the method further comprises the step of cryopreserving the infusion bag comprising the harvested TIL population in step (f) using a cryopreservation process.
- [00604] In some embodiments, the cryopreservation process is performed using a 1:1 ratio of harvested TIL population to cryopreservation media. In some embodiments, the cryopreservation media comprises dimethylsulfoxide. In some embodiments, the cryopreservation media is selected from the group consisting of Cryostor CS10, HypoThermasol, or a combination thereof.
- [00605] In some embodiments, the antigen-presenting cells are peripheral blood mononuclear cells (PBMCs).
- [00606] In some embodiments, the PBMCs are irradiated and allogeneic.
- [00607] In some embodiments, the PBMCs are added to the cell culture on any of days 9 through 14 in step (d).
- [00608] In some embodiments, the antigen-presenting cells are artificial antigen-presenting cells.
- [00609] In some embodiments, the harvesting in step (e) is performing using a LOVO cell processing system.
- [00610] In some embodiments, the tumor fragments are multiple fragments and comprise about 4 to about 50 fragments, wherein each fragment has a volume of about  $27 \text{ mm}^3$ . In some embodiments, the multiple fragments comprise about 30 to about 60 fragments with a total volume of about  $1300 \text{ mm}^3$  to about  $1500 \text{ mm}^3$ . In some embodiments, the multiple fragments comprise about 50 fragments with a total volume of about  $1350 \text{ mm}^3$ . In some embodiments, the multiple fragments comprise about 50 fragments with a total mass of about 1 gram to about 1.5 grams.
- [00611] In some embodiments, the cell culture medium is provided in a container selected from the group consisting of a G-container and a Xuri cellbag.
- [00612] In some embodiments, the infusion bag in step (f) is a HypoThermosol-containing infusion bag.
- [00613] In some embodiments, the first period in step (c) and the second period in step (e) are each individually performed within a period of 10 days, 11 days, or 12 days. In some

embodiments, the first period in step (c) and the second period in step (e) are each individually performed within a period of 11 days. In some embodiments, steps (a) through (f) are performed within a period of about 25 days to about 30 days. In some embodiments, steps (a) through (f) are performed within a period of about 20 days to about 25 days. In some  
5 embodiments, steps (a) through (f) are performed within a period of about 20 days to about 22 days. In some embodiments, steps (a) through (f) are performed in 22 days or less. In some embodiments, steps (a) through (f) and cryopreservation are performed in 22 days or less.

**[00614]** In some embodiments, the therapeutic population of TILs harvested in step (e)  
10 comprises sufficient TILs for a therapeutically effective dosage of the TILs. In some embodiments, the number of TILs sufficient for a therapeutically effective dosage is from about  $2.3 \times 10^{10}$  to about  $13.7 \times 10^{10}$ .

**[00615]** In some embodiments, steps (b) through (e) are performed in a single container, wherein performing steps (b) through (e) in a single container results in an increase in TIL  
15 yield per resected tumor as compared to performing steps (b) through (e) in more than one container.

**[00616]** In some embodiments, the antigen-presenting cells are added to the TILs during the second period in step (d) without opening the system.

**[00617]** In some embodiments, the effector T cells and/or central memory T cells in the  
20 therapeutic population of TILs exhibit one or more characteristics selected from the group consisting of expressing CD27+, expressing CD28+, longer telomeres, increased CD57 expression, and decreased CD56 expression relative to effector T cells, and/or central memory T cells obtained from the second population of cells.

**[00618]** In some embodiments, the effector T cells and/or central memory T cells obtained  
25 from the third population of TILs exhibit increased CD57 expression and decreased CD56 expression relative to effector T cells and/or central memory T cells obtained from the second population of cells.

**[00619]** In some embodiments, the risk of microbial contamination is reduced as compared to an open system.

30 **[00620]** In some embodiments, the TILs from step (f) are infused into a patient.

**[00621]** In some embodiments, the multiple fragments comprise about 4 fragments. In some embodiments, the 4 fragments are placed into a G-REX -100. In some embodiments, the 4 fragments are about 0.5 cm in diameter. In some embodiments, the 4 fragments are placed into a G-REX -100. In some embodiments, the 4 fragments are about 0.1 cm, 0.2 cm, 0.3 cm, 0.4 cm, 0.5 cm, 0.6 cm, 0.7 cm, 0.8 cm, 0.9 cm, or 1 cm in diameter. In some embodiments, the 4 fragments are about 0.1 cm, 0.2 cm, 0.3 cm, 0.4 cm, 0.5 cm, 0.6 cm, 0.7 cm, 0.8 cm, 0.9 cm, or 1 cm in diameter and are placed into a G-REX -100. In some embodiments, the 4 fragments are about 0.1 cm, 0.2 cm, 0.3 cm, 0.4 cm, 0.5 cm, 0.6 cm, 0.7 cm, 0.8 cm, 0.9 cm, or 1 cm in diameter are placed into a container with an equivalent volume to a G-REX -100. In some embodiments, the 4 fragments are about 0.5 cm in diameter and are placed into a G-REX -100. In some embodiments, the 4 fragments are about 0.5 cm in diameter and are placed into a container with an equivalent volume to a G-REX -100.

**[00622]** Further details of steps (a), (b), (c), (d), (e) and (f) are provided herein below, including for example but not limited to the embodiments described under the headings “STEP A: Obtain Patient Tumor Sample”, “STEP B: First Expansion”, “STEP C: First Expansion to Second Expansion Transition”, “STEP D: Second Expansion”, “STEP E: Harvest TILS and “STEP F: Final Formulation/ Transfer to Infusion Bag”.

**[00623]** In some embodiments, the present disclosure provides methods for treating a subject with cancer, the method comprising administering expanded tumor infiltrating lymphocytes (TILs) comprising:

- (a) obtaining a first population of TILs from a tumor resected from a subject by processing a tumor sample obtained from the patient into multiple tumor fragments;
- (b) adding the tumor fragments into a closed system;
- (c) performing a first expansion by culturing the first population of TILs in a cell culture medium comprising IL-2 to produce a second population of TILs, wherein the first expansion is performed in a closed container providing a first gas-permeable surface area, wherein the first expansion is performed for about 3-14 days to obtain the second population of TILs, wherein the second population of TILs is at least 50-fold greater in number than the first population of TILs, and wherein the transition from step (b) to step (c) occurs without opening the system;
- (d) performing a second expansion by supplementing the cell culture medium of the

- second population of TILs with additional IL-2, OKT-3, and antigen presenting cells (APCs), to produce a third population of TILs, wherein the second expansion is performed for about 7-14 days to obtain the third population of TILs, wherein the third population of TILs is a therapeutic population of TILs which comprises an increased subpopulation of effector T cells and/or central memory T cells relative to the second population of TILs, wherein the second expansion is performed in a closed container providing a second gas-permeable surface area, and wherein the transition from step (c) to step (d) occurs without opening the system;
- 5
- 10 (e) harvesting the therapeutic population of TILs obtained from step (d), wherein the transition from step (d) to step (e) occurs without opening the system; and
- (f) transferring the harvested TIL population from step (e) to an infusion bag, wherein the transfer from step (e) to (f) occurs without opening the system;
- (g) optionally cryopreserving the infusion bag comprising the harvested TIL population from step (f) using a cryopreservation process; and
- 15 (h) administering a therapeutically effective dosage of the third population of TILs from the infusion bag in step (g) to the patient.

- [00624]** In some embodiments, the invention provides a therapeutic population of tumor infiltrating lymphocytes (TILs) for use in treating cancer, wherein the population is obtainable from a method comprising the steps of:
- 20 (b) adding tumor fragments into a closed system wherein the tumour fragments comprise a first population of TILs;
- (c) performing a first expansion by culturing the first population of TILs in a cell culture medium comprising IL-2 to produce a second population of TILs, wherein the first expansion is performed in a closed container providing a first gas-permeable surface area, wherein the first expansion is performed for about 3-14 days to obtain the second population of TILs, wherein the second population of TILs is at least 50-fold greater in number than the first population of TILs, and wherein the transition from step (b) to step (c) occurs without opening the system;
- 25
- 30 (d) performing a second expansion by supplementing the cell culture medium of the second population of TILs with additional IL-2, OKT-3, and antigen presenting cells (APCs), to produce a third population of TILs, wherein the second expansion

is performed for about 7-14 days to obtain the third population of TILs, wherein the third population of TILs is a therapeutic population of TILs which comprises an increased subpopulation of effector T cells and/or central memory T cells relative to the second population of TILs, wherein the second expansion is performed in a closed container providing a second gas-permeable surface area, and wherein the transition from step (c) to step (d) occurs without opening the system;

- 5
- (e) harvesting the therapeutic population of TILs obtained from step (d), wherein the transition from step (d) to step (e) occurs without opening the system; and
- 10 (f) transferring the harvested TIL population from step (e) to an infusion bag, wherein the transfer from step (e) to (f) occurs without opening the system; and
- (g) optionally cryopreserving the infusion bag comprising the harvested TIL population from step (f) using a cryopreservation process.

15 **[00625]** In some embodiments, the population is obtainable by a method also comprising as a first step:

(a) obtaining a first population of TILs from a tumor resected from a patient by processing a tumor sample obtained from the patient into multiple tumor fragments.

**[00626]** In an embodiment, the method is an *in vitro* or an *ex vivo* method.

20 **[00627]** In some embodiments, any of steps (a) to (f) comprise one or more features disclosed herein, e.g. one or more features disclosed under the headings “STEP A: Obtain Patient Tumor Sample”, “STEP B: First Expansion”, “STEP C: First Expansion to Second Expansion Transition”, “STEP D: Second Expansion”, “STEP E: Harvest TILs and “STEP F: Final Formulation/ Transfer to Infusion Bag”.

25 **[00628]** In some embodiments, step (g) comprises one or more features disclosed herein, e.g. one or more features disclosed under the heading “STEP H: Optional Cryopreservation of TILs”. In some embodiments, step (h) comprise one or more features disclosed herein, e.g. one or more features disclosed under the heading “STEP F:1 Pharmaceutical Compositions, Dosages and Dosing Regimens”.

30 **[00629]** In some embodiments, the therapeutic population of TILs harvested in step (e) comprises sufficient TILs for administering a therapeutically effective dosage of the TILs in step (h).

- [00630] In some embodiments, the number of TILs sufficient for administering a therapeutically effective dosage in step (h) is from about  $2.3 \times 10^{10}$  to about  $13.7 \times 10^{10}$ .
- [00631] In some embodiments, the antigen presenting cells (APCs) are PBMCs.
- [00632] In some embodiments, the PBMCs are added to the cell culture on any of days 9  
5 through 14 in step (d).
- [00633] In some embodiments, prior to administering a therapeutically effective dosage of TIL cells in step (h), a non-myeloablative lymphodepletion regimen has been administered to the patient.
- [00634] In some embodiments, there is provided a therapeutic population of tumor  
10 infiltrating lymphocytes (TILs) for use in treating cancer and in combination with a non-myeloablative lymphodepletion regimen. In some embodiments, the non-myeloablative lymphodepletion regimen is administered prior to administering the therapeutic population of tumor infiltrating lymphocytes (TILs).
- [00635] In some embodiments, the non-myeloablative lymphodepletion regimen comprises  
15 the steps of administration of cyclophosphamide at a dose of  $60 \text{ mg/m}^2/\text{day}$  for two days followed by administration of fludarabine at a dose of  $25 \text{ mg/m}^2/\text{day}$  for five days.
- [00636] In some embodiments, the step of treating the patient with a high-dose IL-2 regimen starting on the day after administration of the TIL cells to the patient in step (h).
- [00637] In some embodiments, there is provided a therapeutic population of tumor  
20 infiltrating lymphocytes (TILs) for use in treating cancer and in combination with high-dose IL-2 regimen. In some embodiments, the high-dose IL-2 regimen starts on the day after administration of the therapeutic population of TIL cells.
- [00638] In some embodiments, the high-dose IL-2 regimen comprises 600,000 or 720,000  
25 IU/kg administered as a 15-minute bolus intravenous infusion every eight hours until tolerance.
- [00639] In some embodiments, the effector T cells and/or central memory T cells in the therapeutic population of TILs exhibit one or more characteristics selected from the group consisting of expressing CD27+, expressing CD28+, longer telomeres, increased CD57 expression, and decreased CD56 expression relative to effector T cells, and/or central  
30 memory T cells obtained from the second population of cells.

- [00640] In some embodiments, the effector T cells and/or central memory T cells in the therapeutic population of TILs exhibit increased CD57 expression and decreased CD56 expression relative to effector T cells and/or central memory T cells obtained from the second population of cells.
- 5 [00641] The present disclosure also provides methods for expanding tumor infiltrating lymphocytes (TILs) into a therapeutic population of TILs comprising:
- (a) adding processed tumor fragments from a tumor resected from a patient into a closed system to obtain a first population of TILs;
  - (b) performing a first expansion by culturing the first population of TILs in a cell  
10 culture medium comprising IL-2 to produce a second population of TILs, wherein the first expansion is performed in a closed container providing a first gas-permeable surface area, wherein the first expansion is performed for about 3-14 days to obtain the second population of TILs, wherein the second population of TILs is at least 50-fold greater in number than the first population of TILs, and  
15 wherein the transition from step (a) to step (b) occurs without opening the system;
  - (c) performing a second expansion by supplementing the cell culture medium of the second population of TILs with additional IL-2, OKT-3, and antigen presenting cells (APCs), to produce a third population of TILs, wherein the second expansion  
20 is performed for about 7-14 days to obtain the third population of TILs, wherein the third population of TILs is a therapeutic population of TILs which comprises an increased subpopulation of effector T cells and/or central memory T cells relative to the second population of TILs, wherein the second expansion is performed in a closed container providing a second gas-permeable surface area, and wherein the transition from step (b) to step (c) occurs without opening the  
25 system;
  - (d) harvesting the therapeutic population of TILs obtained from step (c), wherein the transition from step (c) to step (d) occurs without opening the system; and
  - (e) transferring the harvested TIL population from step (d) to an infusion bag, wherein the transfer from step (d) to (e) occurs without opening the system.
- 30 [00642] In some embodiments, the therapeutic population of TILs harvested in step (d) comprises sufficient TILs for a therapeutically effective dosage of the TILs.

[00643] In some embodiments, the number of TILs sufficient for a therapeutically effective dosage is from about  $2.3 \times 10^{10}$  to about  $13.7 \times 10^{10}$ .

[00644] In some embodiments, the method further comprises the step of cryopreserving the infusion bag comprising the harvested TIL population using a cryopreservation process.

5 [00645] In some embodiments, the cryopreservation process is performed using a 1:1 ratio of harvested TIL population to CS10 media.

[00646] In some embodiments, the present disclosure provides methods for treating a subject with cancer, the method comprising administering expanded tumor infiltrating lymphocytes (TILs) comprising:

- 10 (a) obtaining a first population of TILs from a tumor resected from a subject by processing a tumor sample obtained from the patient into multiple tumor fragments;
- (b) adding the tumor fragments into a closed system;
- (c) performing a first expansion by culturing the first population of TILs in a cell  
15 culture medium comprising IL-2 to produce a second population of TILs, wherein the first expansion is performed in a closed container providing a first gas-permeable surface area, wherein the first expansion is performed for about 3-14 days to obtain the second population of TILs, wherein the second population of TILs is at least 50-fold greater in number than the first population of TILs, and  
20 wherein the transition from step (b) to step (c) occurs without opening the system;
- (d) performing a second expansion by supplementing the cell culture medium of the second population of TILs with additional IL-2, OKT-3, and antigen presenting cells (APCs), to produce a third population of TILs, wherein the second expansion  
25 is performed for about 7-14 days to obtain the third population of TILs, wherein the third population of TILs is a therapeutic population of TILs which comprises an increased subpopulation of effector T cells and/or central memory T cells relative to the second population of TILs, wherein the second expansion is performed in a closed container providing a second gas-permeable surface area, and wherein the transition from step (c) to step (d) occurs without opening the  
30 system;
- (e) harvesting the therapeutic population of TILs obtained from step (d), wherein the transition from step (d) to step (e) occurs without opening the system; and

- (f) transferring the harvested TIL population from step (e) to an infusion bag, wherein the transfer from step (e) to (f) occurs without opening the system;
- (g) optionally cryopreserving the infusion bag comprising the harvested TIL population from step (f) using a cryopreservation process; and
- 5 (h) administering a therapeutically effective dosage of the third population of TILs from the infusion bag in step (g) to the patient.

wherein no selection of TIL population is performed during any of steps (a) to (h). In an embodiment, no selection of the second population of TILs (the pre-REP population) based on phenotype is performed prior to performing the second expansion of step (d). In an  
10 embodiment, no selection of the first population of TILs, second population of TILs, third population of TILs, or harvested TIL population based on CD8 expression is performed during any of steps (a) to (h).

**[00647]** In some embodiments, the present disclosure provides methods for treating a subject with cancer, the method comprising administering expanded tumor infiltrating lymphocytes  
15 (TILs) comprising:

- (a) obtaining a first population of TILs from a tumor resected from a subject by processing a tumor sample obtained from the patient into multiple tumor fragments;
- (b) adding the tumor fragments into a closed system;
- 20 (c) performing a first expansion by culturing the first population of TILs in a cell culture medium comprising IL-2 to produce a second population of TILs, wherein the first expansion is performed in a closed container providing a first gas-permeable surface area, wherein the first expansion is performed for about 3-14 days to obtain the second population of TILs, wherein the second population of  
25 TILs is at least 50-fold greater in number than the first population of TILs, and wherein the transition from step (b) to step (c) occurs without opening the system;
- (d) performing a second expansion by supplementing the cell culture medium of the second population of TILs with additional IL-2, OKT-3, and antigen presenting cells (APCs), to produce a third population of TILs, wherein the second expansion  
30 is performed for about 7-14 days to obtain the third population of TILs, wherein the third population of TILs is a therapeutic population of TILs which comprises an increased subpopulation of effector T cells and/or central memory T cells

relative to the second population of TILs, wherein the second expansion is performed in a closed container providing a second gas-permeable surface area, and wherein the transition from step (c) to step (d) occurs without opening the system;

- 5 (e) harvesting the therapeutic population of TILs obtained from step (d), wherein the transition from step (d) to step (e) occurs without opening the system; and
- (f) transferring the harvested TIL population from step (e) to an infusion bag, wherein the transfer from step (e) to (f) occurs without opening the system;
- (g) cryopreserving the infusion bag comprising the harvested TIL population from
- 10 step (f) using a cryopreservation process, wherein the cryopreservation process comprises mixing of a cryopreservation media with the harvested TIL population;
- (h) administering a therapeutically effective dosage of the third population of TILs from the infusion bag in step (g) to the patient.

wherein no selection of TIL population is performed during any of steps (a) to (h). In an

15 embodiment, no selection of the second population of TILs (for example, the pre-REP population) based on phenotype is performed prior to performing the second expansion of step (d). In an embodiment, no selection of the first population of TILs, second population of TILs, third population of TILs, or harvested TIL population based on CD8 expression is performed during any of steps (a) to (h). In some embodiments, the non-myeloablative

20 lymphodepletion regimen is administered prior to administering the harvested TIL population. In some embodiments, the non-myeloablative lymphodepletion regimen comprises the steps of administration of cyclophosphamide at a dose of 60 mg/m<sup>2</sup>/day for two days followed by administration of fludarabine at a dose of 25 mg/m<sup>2</sup>/day for five days.

[00648] In some embodiments, the antigen-presenting cells are peripheral blood

25 mononuclear cells (PBMCs). In some embodiments, the PBMCs are irradiated and allogeneic. In some embodiments, the PBMCs are added to the cell culture on any of days 9 through 14 in step (c).

[00649] In some embodiments, the antigen-presenting cells are artificial antigen-presenting cells.

30 [00650] In some embodiments, the harvesting in step (d) is performed using a LOVO cell processing system.

[00651] In some embodiments, the method comprises harvesting in step (d) is via a LOVO cell processing system, such as the LOVO system manufactured by Fresenius Kabi. The term “LOVO cell processing system” also refers to any instrument or device that can pump a solution comprising cells through a membrane or filter such as a spinning membrane or spinning filter in a sterile and/or closed system environment, allowing for continuous flow and cell processing to remove supernatant or cell culture media without pelletization. In some cases, the cell processing system can perform cell separation, washing, fluid-exchange, concentration, and/or other cell processing steps in a closed, sterile system.

[00652] In some embodiments, the tumor fragments are multiple fragments and comprise about 4 to about 50 fragments, wherein each fragment has a volume of about  $27 \text{ mm}^3$ . In some embodiments, the multiple fragments comprise about 30 to about 60 fragments with a total volume of about  $1300 \text{ mm}^3$  to about  $1500 \text{ mm}^3$ . In some embodiments, the multiple fragments comprise about 50 fragments with a total volume of about  $1350 \text{ mm}^3$ . In some embodiments, the multiple fragments comprise about 50 fragments with a total mass of about 1 gram to about 1.5 grams.

[00653] In some embodiments, the multiple fragments comprise about 4 fragments. In some embodiments, the 4 fragments are placed into a G-REX-100. In some embodiments, the 4 fragments are about 0.1 cm, 0.2 cm, 0.3 cm, 0.4 cm, 0.5 cm, 0.6 cm, 0.7 cm, 0.8 cm, 0.9 cm, or 1 cm in diameter. In some embodiments, the 4 fragments are about 0.1 cm, 0.2 cm, 0.3 cm, 0.4 cm, 0.5 cm, 0.6 cm, 0.7 cm, 0.8 cm, 0.9 cm, or 1 cm in diameter and are placed into a G-REX-100. In some embodiments, the 4 fragments are about 0.1 cm, 0.2 cm, 0.3 cm, 0.4 cm, 0.5 cm, 0.6 cm, 0.7 cm, 0.8 cm, 0.9 cm, or 1 cm in diameter are placed into a container with an equivalent volume to a G-REX-100. In some embodiments, the 4 fragments are about 0.5 cm in diameter and are placed into a G-REX-100. In some embodiments, the 4 fragments are about 0.5 cm in diameter and are placed into a container with an equivalent volume to a G-REX-100.

[00654] In some embodiments, the cell culture medium is provided in a container selected from the group consisting of a G-container and a Xuri cellbag.

[00655] In some embodiments, the infusion bag in step (e) is a HypoThermosol-containing infusion bag.

**[00656]** In some embodiments, the first period in step (b) and the second period in step (c) are each individually performed within a period of 10 days, 11 days, or 12 days. In some embodiments, the first period in step (b) and the second period in step (c) are each individually performed within a period of 11 days. In some embodiments, steps (a) through (e) are performed within a period of about 25 days to about 30 days. In some embodiments, steps (a) through (e) are performed within a period of about 20 days to about 25 days. In some embodiments, steps (a) through (e) are performed within a period of about 20 days to about 22 days. In some embodiments, steps (a) through (e) are performed in 22 days or less. In some embodiments, steps (a) through (e) and cryopreservation are performed in 22 days or less.

**[00657]** In some embodiments, steps (b) through (e) are performed in a single container, wherein performing steps (b) through (e) in a single container results in an increase in TIL yield per resected tumor as compared to performing steps (b) through (e) in more than one container.

**[00658]** In some embodiments, the antigen-presenting cells are added to the TILs during the second period in step (c) without opening the system.

**[00659]** In some embodiments, the effector T cells and/or central memory T cells obtained in the therapeutic population of TILs exhibit one or more characteristics selected from the group consisting of expressing CD27+, expressing CD28+, longer telomeres, increased CD57 expression, and decreased CD56 expression relative to effector T cells, and/or central memory T cells obtained from the second population of cells.

**[00660]** In some embodiments, the effector T cells and/or central memory T cells obtained in the therapeutic population of TILs exhibit increased CD57 expression and decreased CD56 expression relative to effector T cells, and/or central memory T cells obtained from the second population of cells.

**[00661]** In some embodiments, the risk of microbial contamination is reduced as compared to an open system.

**[00662]** In some embodiments, the TILs from step (e) are infused into a patient.

**[00663]** In some embodiments, the closed container comprises a single bioreactor. In some embodiments, the closed container comprises a G-REX-10. In some embodiments, the closed container comprises a G-REX-100.

## EXAMPLES

[00664] The embodiments encompassed herein are now described with reference to the following examples. These examples are provided for the purpose of illustration only and the disclosure encompassed herein should in no way be construed as being limited to these examples, but rather should be construed to encompass any and all variations which become evident as a result of the teachings provided herein.

### EXAMPLE 1: CLOSED SYSTEM ASSAYS

[00665] As discussed herein, protocols and assays were developed for generating TIL from patient tumors in a closed system.

[00666] This Example describes a novel abbreviated procedure for generating clinically relevant numbers of TILs from patients' resected tumor tissue in G-REX devices and cryopreservation of the final cell product. Additional aspects of this procedure are described in Examples 2 to 8.

#### 15 Definitions/Abbreviations

- BSC - Biological Safety Cabinet
- °C – degrees Celsius
- CO<sub>2</sub> - Carbon dioxide
- CD3 – Cluster of Differentiation 3
- 20 CM1 – Complete Medium 1
- CM2 – Complete Medium 2
- TIWB – Tumor Isolation Wash Buffer
- CM4 – Complete Medium 4
- CRF – Control Rate Freezer
- 25 EtOH - ethanol
- GMP – Good Manufacturing Practice
- IL-2, rIL-2 –Interleukin-2, Recombinant human Interleukin-2,
- IU – International Unit
- L - Liter
- 30 LN2 – liquid nitrogen
- mL - milliliter
- μl - microliter
- mM - millimolar
- μm - micrometer
- 35 NA – Not Applicable
- PBMC – Peripheral Blood Mononuclear Cell
- PPE – Personal Protective Equipment

Pre-REP – Initial TIL cultures originating from tumor fragments

REP – Rapid Expansion Protocol

TIL – Tumor Infiltrating Lymphocytes

TIWB – TIL Isolation Wash Buffer

5 SOP – Standard Operating Procedure

#### Procedure

##### 1. Advanced preparation: Day 0 (Performed up to 36 hours in advance)

10 1.1 Prepared TIL Isolation Wash Buffer (TIWB) by supplementing 500 mL Hanks Balanced Salt Solution with 50 µg/mL Gentamicin. For 10 mg/mL Gentamicin stock solution transferred 2.5 mL to HBSS. For 50 mg/mL stock solution transferred 0.5 mL to HBSS.

15 1.2. Prepared CM1 media with GlutaMax™ per LAB-005 “Preparation of media for PreREP and REP” for CM2 instructions”. Store at 4 °C up to 24 hours. Allowed to warm at 37°C for at least 1 hour prior to use.

1.3. Removed IL-2 aliquot(s) from -20°C freezer and placed aliquot(s) in 2-8°C refrigerator.

##### 2. Receipt of tumor tissue

20 2.1. Kept all paperwork received with tumor tissue and obtained photos of transport container and tumor tissue.

2.2. If TempTale was provided printed and saved the associated document; saved the PDF.

2.3. Removed tumor specimen and secondary container (zip top bag) from shipper and stored at 4 °C until ready for processing.

25 2.4 Shipped unused tumor either in HypoThermasol or as frozen fragments in CryoStor CS10 (both commercially available from BioLife Solutions, Inc.).

##### 3. Tumor processing for TIL

3.1. Aseptically transferred the following materials to the BSC, as needed, and labeled according to Table 3 below.

30 TABLE 3. Materials for tumor isolation.

Item	Minimum Quantity	In-Process Label
Tumor	1	N/A
Petri dish, 150 mm	1	Dissection
Petri dish, 100 mm	4	Wash 1, 2, 3, 4
Petri dish, 100 mm	1	Unfavorable Tissue
6 well plate	2	Lid Label – “Tumor Fragments” Plate Bottom – “Favorable Tissue”
Ruler	2	N/A
Wash Buffer	1	N/A

Forceps	1	N/A
Long forceps	1	N/A
Scalpel	As needed	N/A

- 3.2. Labeled the circles of the Tumor Fragments Dishes with the letters A-J.
- 3.3. Labeled the undersides of the wells of the Favorable Tissue Dishes with the letters A – J.
- 3.4. Transferred 5 mL Gentamicin to the HBSS bottle. Labeled as TIWB.
- 5 3.5. Swirled to mix.
- 3.6. Pipetted 50 mL TIWB to each of the following:
1. Wash 1 dish
  2. Wash 2 dish
  - 10 3. Wash 3 dish
  4. Wash 4 dish
- 3.7. Pipetted 2 mL TIWB into wells A-J of the Favorable Tissue Dish.
- 3.8. Covered the Favorable Tissue Dishes (6-well plate bottom) with the corresponding Tumor Fragments Dish (6-well plate lid).
- 15 3.9. Using long forceps, removed the tumor(s) from the Specimen bottle and transferred to the Wash 1 dish.
- 3.10. Incubated the tumor at ambient temperature in the Wash 1 dish for 3 minutes.
- 3.11. During the incubation, relabeled the Specimen bottle “Bioburden” and stored at 2-8 °C until submitted to Quality Control for testing.
- 3.12. Discarded long forceps and used short forceps for further manipulations.
- 20 3.13. Using forceps transferred the tumor to the Wash 2 dish.
- 3.14. Incubated the tumor at ambient temperature in the Wash 2 dish for 3 minutes.
- 3.15. Using forceps transferred the tumor to the Wash 3 dish.
- 3.16. Incubated the tumor at ambient in the Wash 3 dish for 3 minutes.
- 25 3.17. Removed the Tumor Fragment Dishes (6-well plate lids) from the Favorable Tissue Dishes (6-well plate bottoms) and placed the Tumor Fragments Dishes upside down on the BSC surface.
- 3.18. Using a transfer pipette, added approximately 4 evenly-spaced, individual drops of TIWB to each circle of the Tumor Fragments dishes.
- 3.19. Placed a ruler underneath the Dissection dish.
- 30 3.20. Using forceps transferred the tumor to the Dissection dish.
- 3.21. Using the ruler under the Dissection dish, measured and recorded the length of the tumor.
- 3.22. For tumors greater than 1 cm additional Favorable Tissue Dishes were made.

- 3.23. Performed an initial dissection of the tumor pieces in the Dissection dish into 10 intermediate pieces and care was taken to conserve the tumor structure of each intermediate piece.
- 5 3.24. Transferred any intermediate tumor pieces not being actively dissected into fragments to the Wash 4 dish to ensure the tissue remained hydrated during the entire dissection procedure.
- 10 3.25. Working with one intermediate tumor piece at a time, carefully sliced the tumor into up to 3x3x3 mm fragments in the Dissection Dish, using the ruler underneath the dish for reference. When scalpel became dull, replaced with a new scalpel.
- 3.26. Continued dissecting fragments from the intermediate tumor piece until all tissue in the intermediate piece had been evaluated.
- 15 3.27. Selected favorable fragments and using a transfer pipette transferred up to 4 favorable fragments into the TIWB drops in one circle in the Tumor Fragments dish.
- 3.28. Using a transfer pipette transferred any remaining favorable fragments from the tumor piece, when available, to the corresponding well in the Favorable Tissue Dish.
- 20 3.29. Using a transfer pipette transferred as much as possible of the unfavorable tissue and waste product to the Unfavorable Tissue dish to clear the dissection dish. Unfavorable tissue was indicated by yellow adipose tissue or necrotic tissue.
- 25 3.30. Continued processing by repeating step 7.3.25-7.3.30 for the remaining intermediate tumor pieces, working one intermediate piece at a time until all of the tumor had been processed.
- 30 3.31. If fewer than 4 tumor fragments were available in the corresponding circle of the Tumor Fragments Dish, it was acceptable to use fragments from a non-corresponding well of the Favorable Tissue Dish as available to achieve the 40 fragment goal. When less than 40 fragments, 10-40 were placed in a singled G-Rex 100M flask.

#### 4. Seeding G-Rex 100M flask

- 4.1. Aseptically transferred the following materials to the BSC, as needed, and labeled according to the Table 4 below.

TABLE 4. Additional Materials for Seeding Flasks.

Item	Minimum Quantity	In-Process Label
G-Rex 100M flask	As Needed	Lot#
Warm CM1	As Needed	Lot#
IL-2 Aliquots	As Needed	Lot#

- 35 4.2. Supplemented each liter of CM1 with 1 mL of IL-2 stock solution ( $6 \times 10^6$  IU/mL).

- 4.3. Placed 1000 mL of pre-warmed CM1 containing 6,000 IU/mL of IL-2 in each G-REX 100M bioreactor needed as determined by Table 5 below.
- 4.4. Using a transfer pipette, transferred the appropriate number of tumor fragments to each G-Rex 100M flask, distributing fragments per Table 5.
- 5 4.5. When one or more tumor fragments transferred to the G-Rex 100M flask float, obtained one additional tumor fragment if available from the Favorable Tissue Dish and transferred it to the G-Rex 100M flask.
- 4.6. Recorded the total number of fragments added to each flask.
- 4.7. Discarded the Unfavorable Tissue dish.
- 10 4.8. Placed each G-REX 100M bioreactor in 37 °C, 5% CO<sub>2</sub> incubator.
- 4.9. When more than 40 fragments were available:
- 4.9.1. When >41 fragments were obtained, placed 1000 mL of pre-warmed complete CM1 in a second G-REX 100M bioreactor.

15 TABLE 5. Number of G-REX bioreactors needed.

Number of Fragments	G-REX	Number of G-REX	CM1 needed
1-40	G-REX 100M	1	1000 mL
41-80 distribute between flasks	G-REX 100M	2	2000 mL
>80	Freeze fragments in CS10 after 15 minute pre-incubation		

5. Advanced Preparation: Day 11 (Prepared up to 24 hours in advance)
- 5.1. Prepared 6 L of CM2 with GlutaMax. Used reference laboratory procedures for "Preparation of media for PreREP and REP" for CM2 instructions". Warmed at 37 °C 1 hour prior to use.
- 20 5.2. Thawed IL-2 aliquots: Removed IL-2 aliquots from freezer and placed at 4 °C.
6. Harvest TIL (Day 11)
- 6.1. Carefully removed G-REX -100M flasks from incubator and placed in BSC2. Were careful to not disturb the cells on the bottom of the flask.
- 25 6.2. Using GatherRex or peristaltic pump aspirated ~900 mL of cell culture supernatant from flask(s).
- 6.3. Resuspended TIL by gently swirling flask. Observed that all cells have been liberated from the membrane.

- 5 6.4. Using peristaltic pump or GatherRex transferred the residual cell suspension to an appropriately sized blood transfer pack (300-1000mL). Was careful to not allow the fragments to be transferred to the blood transfer pack.
- 6.5. Spiked the transfer pack with a 4" plasma transfer set (ensure clamp is closed).
- 6.6. Massaged the pack to ensure the cell suspension was well mixed and using a 3 mL syringe, removed 1 mL TIL suspension for cell counts. Clamped the tubing and recapped female luer connector with a new sterile luer cap.
- 10 6.7. Placed the transfer pack into a plastic zip top bag and replaced into the incubator until ready to use.
7. Media preparation
- 7.1. Allowed media to warm at 37 °C for >1hr.
- 7.2. Added 3 mL of  $6 \times 10^6$  IU/mL stock rhIL-2 to 6 L CM2 to reach a final concentration of 3,000 IU/mL rhIL-2. Label as "complete CM2".
- 15 7.3. Sterile welded a 4" plasma transfer set with female luer to a 1L Transfer pack.
- 7.4. Transferred 500mL complete CM2 to a 1L transfer pack. Detached fluid transfer set or syringe and attached a sterile luer plug to the female luer port.
- 7.5. Spiked the pack with a sample site coupler.
- 20 7.6. Using a 1.0mL syringe with needle drew up 150  $\mu$ L of 1 mg/mL anti-CD3 (clone OKT3) and transferred to 500 mL "complete CM2" through sample site coupler. Drew back on the syringe to ensure all reagent was flushed from the line. Stored at 37 °C until use.
8. Flask preparation
- 25 8.1. Transferred 4.5L "complete CM2" to a G-REX -500M flask using the graduations on the flask for reference.
- 8.2. Placed flask into 37 °C incubator until ready.
9. Thaw irradiated feeders
- 30 9.1. Utilized  $5.0 \times 10^9$  allogenic irradiated feeders from two or more donors for use.
- 9.2. Removed feeders from LN2 freezer and placed in a biohazard transport bag.
- 9.3. With feeder bags in the biohazard transport bag, thawed feeders in 37 °C incubator or bead bath. Kept bags static and submerged. Removed feeders from bath when almost completely thawed but still cold.
- 35 9.4. Sprayed or wiped feeder bags with 70% EtOH and place in BSC2. Added each feeder bag directly to the open G-Rex 500M to assure sufficient number of irradiated cells ( $5 \times 10^9$  cells, +/- 20%).
- 9.5. Closed both clamps on a fenwal Y type connector with male luer lock.
- 9.6. Spiked each feeder bag with a leg of the Y connector.

- 9.7. Removed 1L transfer pack with 500 mL “complete CM2” + OKT3 and transferred to BSC.
- 9.8. Aseptically attached a 60mL syringe to a 3 way stopcock, and aseptically attached the transfer pack to the male end of the stopcock.
- 5 9.9. Aseptically attached the Y connector to the 3 way stopcock.
- 9.10. Drew the entire contents of the feeder bags into the syringe, recorded the volume, and dispensed  $5.0 \times 10^9$  allogenic irradiated feeders into the transfer pack.
- 10 9.11. Clamped and detached transfer pack from apparatus, and plug female luer lock with a new sterile luer plug.
- 9.12. Using a needle and 3 mL syringe pulled 1 mL for cell counts from the sample site coupler.
- 9.13. When +/- 10% of the target cell number ( $5.0 \times 10^9$ ) was reached with >70% viability, proceeded.
- 15 9.14. When less than 90% of the target cell number ( $5.0 \times 10^9$ ) was reached with >70% viability thawed another bag and repeated 7.9.4-7.9.12. When greater than 110% of the target cell number was achieved, calculated the proper volume required for desired cell dose and proceeded.
10. Co-culture TIL and feeders in G-REX 500M flask
- 20 10.1. Removed the G-REX 500M flask containing prepared media from the incubator and placed in the BSC2.
- 10.2. Attached feeder transfer pack to G-REX -500M and allowed contents of the bag to drain into the 500M.
- 10.3. Removed TIL suspension from the incubator and placed in the BSC.
- 25 10.4. Calculated volume of TIL suspension to add to achieve  $200 \times 10^6$  total viable cells.
- $$(TVC/mL) / 200 \times 10^6 = mL$$
- 10.5. When TIL were between  $5-200 \times 10^6$  total viable cells, added all TIL (total volume) to the G-REX -500M. When TIL count was greater than  $200 \times 10^6$  total viable cells, added calculated volume necessary for  $200 \times 10^6$  TIL to be distributed to an individual G-REX -500M. Remaining TIL were spun down and frozen in at least two cryovials at up to  $10^8$ /mL in CS10, labeled with TIL identification and date frozen.
- 30 10.6. Placed the G-REX -500M in a 37°C, 5% CO<sub>2</sub> incubator for 5 days.
- 35 11. Advanced preparation: Day 16-18
- 11.1. Warmed 1 10L bag of AIM V for cultures initiated with less than  $50 \times 10^6$  TIL warmed 2 for those initiated with greater than  $50 \times 10^6$  TIL at 37 °C at least 1 hr or until ready to use.
12. Perform TIL cell count: Day 16-18
- 40 12.1. Removed G-REX -500M flask from incubator and placed in BSC2. Were careful not to disturb the cell culture on the bottom of the flask.

- 12.2. Aseptically removed 4 L of cell culture media from the G-REX -500M flask and placed into a sterile container.
- 12.3. Swirled the G-REX -500M until all TIL had been resuspended from the membrane.
- 5 12.4. Using GatherRex or peristaltic pump transferred cell suspension to a 2L transfer pack. Retained the 500M flask for later use. Sealed the port with the sample site coupler to avoid loss of TILs.
- 12.5. Spiked the transfer pack with a sample site coupler and using a 3mL syringe and needle removed 2×1 mL independent samples for a cell count.
- 10 12.6. Calculated the total number of flasks required for subculture according to the following formula. Rounded fractions up.

$$\text{Total viable cells} / 1.0 \times 10^9 = \text{flask \#}$$

### 13. Prepare CM4

- 15 13.1. Prepared a 10L bag of AIM-V for every two 500M flasks needed. Warmed additional media as necessary.
- 13.2. For every 10 L of AIM-V needed, added 100 mL of GlutaMAX to make CM4.
- 13.3. Supplemented CM4 media with rhIL-2 for a final concentration of 3,000 IU/mL rhIL-2.

### 20 14. Split the cell culture

- 14.1. Using the graduations on the flask, gravity filled each G-REX -500M to 5 L.
- 14.2. Evenly distributed the TIL volume amongst the calculated number of G-REX -500Ms.
- 14.3. Placed flasks in a 37 °C, 5% CO<sub>2</sub> incubator until harvest on Day 22 of REP.

### 25 15. Advanced Preparation: Day 22-24

- 15.1. Prepared 2L of 1% HSA wash buffer by adding 40mL of 25% HSA to each of two 1L bags of PlasmaLyte A 7.4. Pool into a LOVO ancillary bag.
- 15.2. Supplemented 200 mL CS10 with IL-2 @ 600 IU/mL.
- 15.3. Pre-cooled four 750 mL aluminum freezer canisters at 4 °C.

### 30 16. Harvest TIL: Day 22-24

- 16.1. Removed the G-REX -500M flasks from the 37 °C incubator and placed in the BSC2. Were careful to not disturb the cell culture on the bottom of the flask.
- 16.2. Aspirated and discarded 4.5 L of cell culture supernatant from each flask.
- 35 16.3. Swirled the G-REX -500M flask to completely resuspend the TIL.
- 16.4. Weighed the 3-5L bioprocess bag prior to use.
- 16.5. Using GatherRex or peristaltic pump, harvested TIL into the bioprocess bag.

16.6. Mixed bag well and using a 3mL syringe take  $2 \times 2$  mL samples from the syringe sample port for cell counting.

16.7. Weighed the bag and found the difference between the initial and final weight. Used the following calculation to determine the volume of cell suspension.

$$\text{Net weight of cell suspension (mL)} / 1.03 = \text{volume (mL)}$$

17. Filter TIL and prepare LOVO Source bag

17.1. Placed the bag containing cell culture into the BSC2.

17.2. Placed a 170  $\mu$ m blood filter into the BSC2 and closed all clamps.

17.3. Sterile welded a source leg of the filter to the cell suspension.

17.4. Weighed a new appropriately sized bioprocess bag (this was referred to as the LOVO source bag).

17.5. Sterile welded the terminal end of the filter to the LOVO source bag.

17.6. Elevated the cell suspension by hanging cells on an IV pole to set up a gravity-flow transfer of cells.

Note: (Did not allow the source bag to hang from the filtration apparatus.)

17.7. Opened all necessary clamps and allowed TIL to drain from the cell suspension bag through the filter and into the LOVO source bag.

17.8. Once all cells were transferred to the LOVO source bag, closed all clamps and sealed the LOVO source bag tubing to remove filter.

17.9. Weighed the LOVO source bag and calculate volume.

17.10. The LOVO source bag was ready for the LOVO.

17.11. Removed the LOVO final product bag from the disposable kit by sealing the tubing near the bag.

18. Formulate TIL 1:1 in cold CS10 supplemented with 600 IU/mL rhIL-2

18.1. Calculated required number of cryobags needed.

$$(\text{volume of cell product} \times 2) / 100 = \text{number of required bags (round down)}$$

18.2. Calculated the volume to dispense into each bag.

$$(\text{volume of cell product} \times 2) / \text{number of required bags} = \text{volume to add to each bag}$$

18.3. Aseptically transferred the following materials in Table 6 to the BSC.

TABLE 6. Materials for TIL cryopreservation.

Item	Minimum Quantity	In-Process Label
Cell product	1	Lot#
Aluminum freezer cassette (750 ml)	1	n/a
Cold CS10 + IL-2 @600IU/mL	As Needed	Lot#

Cell Connect CC1 device	1	n/a
750 mL cryobags	calculated	Label aliquots 1- largest#
100 mL syringe	#cryobags +1	n/a
3 way stopcock	1	n/a
Cryovials	5	TIL Cryo-product satellite vials

## 19. TIL formulation

- 19.1. Closed all clamps on Cell Connect CC1.
- 19.2. To the cell connect device aseptically attached the LOVO final product, CS10 bag luer lock and the appropriate number of cryobags. Replaced the 60 mL syringe with a 100 mL syringe.
- 19.3. The amount of CS10 volume needed was equivalent to the volume of the LOVO final product bag.
- 19.4. Opened the stopcock pathway and unclamp the line between the LOVO final product bag and syringe to pull CS10 into the syringe, reclamp CS10 path. Unclamped pathway to the cell bag to push CS10 into the LOVO final product bag. Used the syringe to measure the volume added to the LOVO final product bag. Repeated as necessary using a new syringe until desired amount of CS10 is transferred.
- 19.5. Mixed LOVO final product bag by inversion.
- 19.6. Replaced 100 mL syringe
- 19.7. Opened clamps on 750 mL cryobags one at a time
- 19.8. Only opened clamps that are directly associated with the formulated product and the cryobag in use.
- 19.9. Used the 100 mL syringe to measure the volume of formulated product leading to the cryobag.
- 19.10. Transferred 100 mL of formulated product into each cryobag.
- 19.11. After addition to each bag pulled back on the syringe to remove all air bubbles from cryobags and reclamped the associated line.
- 19.12. On the final bag pull back a 10 mL retain for QC testing.
- 19.13. Sealed each cryobag, leaving as little tubing as possible.
- 19.14. Removed the syringe containing the retained sample and transferred to a 50mL conical tube; transferred 1.5ml into individual cryovials and froze into a controlled rate freezer.
- 19.15. Transferred sealed bags to 4 °C while labels were prepared.
- 19.16. Labeled each cryobag with product description, name and date, volume, cell count, and viability.
- 19.17. Placed each cryobag into pre-cooled aluminum freezer canisters.

20. Cryopreservation of TIL using Control Rate Freezer (CRF)
- 20.1. Followed standard procedure for the controlled rate freezer.
- 20.2. After using the CRF, stored cryobags in liquid nitrogen (LN<sub>2</sub>).
21. Determined expected results and measure acceptance criteria.

5

### EXAMPLE 2: PROCESS RUN ON 8 PATIENT TUMORS

[00667] The process of Example 1 was run using 8 patient tumors to produce 8 batches of TILs. Good recovery from culture, viability, cell counts, CD3<sup>+</sup> (indicating the % T cell content) and IFN-gamma (IFN-g or IFN- $\gamma$ ) release were obtained, as shown in Table 7 below and in Figure 7 through Figure 10.

10

TABLE 7. Results of Testing of Identity, Potency, and Viability/Recovery of the Process of Example 1.

	IFNg (pg/1e6 cells/24hr)	CD3 (%)		Cells/mL (Viable+Nonviable)		% Recovery		%Viability	
						Fresh/Lovo			
M1061T	4570		95.3		1.27E+08		103		88.1
M1062T	3921		99.7		1.65E+08		89		84.5
M1063T	5587		98.7		1.51E+08		112		82.1
M1064T	619		84.5		1.75E+08		83		86.8
M1065T	1363		96.8		3.42E+07		128		76.4
EP11001T	4263		90.4		1.82E+08		92		77.9
M1056T	6065		94.2		2.11E+08		85		84.8
M1058T	1007		99		2.72E+08		89		87.5

15

### EXAMPLE 3: SCALABILITY OF MODIFIED TIL PROCESS

[00668] The studies presented here were performed in a process development (PD) lab, and subsequently, a process qualification (PQ) study utilizing engineering runs was performed in the GMP clean room suite at a manufacturing facility. Three PQ/engineering runs were completed in the GMP facility clean room according to a qualification protocol, and a batch record based on the PD studies presented here. Acceptance criteria for the engineering runs were set prospectively. The PQ study is further summarized below, and test results obtained for the engineering batches are provided in the following sections.

20

**[00669]** The number of cells generated from pre-rapid expansion protocol (pre-REP) cultures often exceeded  $100 \times 10^6$  viable cells. In addition, including a freeze-thaw cycle between the Pre-REP and REP culture steps reduced the viable cell yield. By eliminating the in-process cryopreservation step, the REP could be reliably and regularly initiated with an increased number of TIL. This change allowed the duration of the REP to be decreased by a proportional amount of cell doubling times to roughly 11 days without impacting cell dose. In addition, the reduced culture time from activation to harvest results in a product that is less differentiated and potentially better able to persist in-vivo (Tran 2008).

**[00670]** The PD study validated the initiation of the REP culture with up to  $200 \times 10^6$  cells with a fixed number of feeder cells. The optimal time to harvest the REP culture was then evaluated over 9 to 14 days. Cultures were seeded at feeder to TIL ratios ranging from 100:1 to 25:1. Optimization of harvest time was determined by measuring total cell count, viability, immunophenotype, media consumption, metabolite analysis, interleukin-2 (IL-2) analysis, and the functional analyses described below.

**[00671]** Immunophenotyping of cells at the end of the REP culture was evaluated on the basis of the markers listed in Table 8 below. The phenotypic activation and differentiation state of the cells was evaluated. Statistical differences in phenotype were not observed among any of the experimental conditions.

TABLE 8. Markers of Activation and Differentiation Assayed on Process Optimization Cultures.

Target	Label for Detection	Clone
<b>Panel 1</b>		
TCRab ( <i>i.e.</i> , TCR $\alpha/\beta$ )	PE/Cy7	IP26
CD57	PerCP-Cy5.5	HNK-1
CD28	PE	CD28.2
CD4	FITC	OKT4
CD27	APC-H7	M-T271
CD56	APC	N901
CD8a	PB	RPA-T8
<b>Panel 2</b>		
CD45RA	PE/Cy7	HI100
CD3	PerCP/Cy5.5	SP34-2
CCR7	PE	150503
CD8	FITC	HIT8
CD4	APC/Cy7	OKT4
CD38	APC	HB-7
HLA-DR	PB	L243
<b>Panel 3</b>		
CD137	PE/Cy7	4B4-1
CD3	PerCP/Cy5.5	SP34-2
Lag3	PE	3DS223H
CD8	FITC	HIT8
CD4	APCCy7	OKT4
PD1	APC	EH12.2H7
Tim-3	BV421	F38-2E2

- [00672] Abbreviations: PE/Cy7=Phycoerythrin: Cy-7 Tandem Conjugate; PerCP-Cy5.5=Peridinin-chlorophyll-protein Complex:CY5.5 Conjugate; PE=Phycoerythrin; FITC=Fluorescein Isothiocyanate Conjugate; APC-H7=Allophycocyanin:H7 Tandem Conjugate; APC=Allophycocyanin; PB=Pacific Blue™

[00673] Media consumption and metabolite production remained within tolerable limits for all conditions tested; and IL-2 levels remained greater than 150 IU/mL of culture supernatant (data not shown).

- 10 [00674] Tumor cell killing by T-cells is understood to be mediated by activation of the T-cell receptor on the effector T-cell in response to peptides presented on the surface of tumor cells. *Ex vivo* expanded T-cells must retain the ability to be activated and proliferate in response to TCR activation if they are to persist *in vivo* upon infusion and mediate tumor regression.

[00675] To assess the activation potential of the cultured cells, TIL harvested at different time points were reactivated with irradiated allogeneic PBMC loaded with OKT3. TIL cultures were harvested after 7 days and assayed for fold-expansion. The results of this study are summarized in TABLE 9.

5 TABLE 9. Summary of Results: Proliferation of Post-REP TIL Upon Re-culture with OKT3 Loaded Allogeneic PBMC.

Harvest Day	Fold-Expansion	SD	P-value (Student 't'test)
<b>Experiment 1</b>			
Day 9	43	6.088	NA
Day 10	48	3.105	NA
Day 11	71	11.137	0.135
Day 14	60	6.995	
<b>Experiment 2</b>			
Day 9	44	6.276	NA
Day 10	27	4.762	NA
Day 11	72	18.795	0.045
Day 14	41	7.050	
<b>Experiment 3</b>			
Day 9	54	5.810	NA
Day 10	54	9.468	NA
Day 11	65	1.674	0.071
Day 14	50	8.541	

[00676] This study demonstrated that the potential for TIL to be activated in this assay increased with each day of culture through Day 11 (harvest Days 9–11). Cells harvested on Day 11 of the modified process performed similarly to control TIL maintained in culture for 10 14 days similar to the current process.

[00677] These studies demonstrated the scalability of the modified TIL process and established an acceptable range of seeding ratios of TIL to feeder cells. In addition, the growth characteristics were found to persist through Day 14 of culture, while culture conditions remained optimal through Day 11. The conditions tested showed no measurable 15 effect on TIL phenotype. Cells harvested on REP culture Day 11 demonstrated the best ability to respond to reactivation while the cell culture conditions remained within tolerances. These changes were adopted and validated at full scale with the culture split occurring on Day 5 and harvest on Day 11.

[00678] Engineering runs were implemented at the process development facility in order to gain experience in manufacturing and testing the TIL product prior to the GMP manufacturing of autologous TIL product for administration to patients. The manufacturing procedure used for the engineering runs was at the same scale as that to be used in the manufacturing of GMP TIL product. Experience in growing TIL from various types of tumors including metastases of melanoma, breast, head and neck squamous cell carcinoma (HNSCC), cervical carcinoma, and lung cancer has determined that the dissection and outgrowth of TIL from metastatic tumor samples is similar for these cancers (Sethuraman 2016, JITC P42). Because the initial isolation of tumor fragments and outgrowth of lymphocytes appears to be similar between tumor histologies, these engineering runs are sufficient to qualify the process for the production of TIL from HNSCC, cervical and melanoma tumors.

[00679] Table 10 shows the source and characteristics of tumor samples used for the engineering runs.

15 TABLE 10. Tumor Samples Tested for Engineering Runs.

Tumor Sample	Engineering Run 1	Engineering Run 2	Engineering Run 3
Patient ID	1001185	600-D455	40231
Source	Biotheme Research	BioOptions	Moffitt
Tissue	Lung, Left	Breast, ERPR+Her2-	Melanoma
Date Processed	Jan 5, 2017	Jan 12, 2017	Jan 26, 2017

[00680] Release testing of the three engineering runs of TIL at the process development facility was completed (Table 11) as described below. Product was tested on Day 16 and Day 22. IFN- $\gamma$  secretion was also determined for the three engineering runs (Table 12) as detailed elsewhere.

TABLE 11. Product Release Test Results for Engineering Runs at Process Development Facility.

	Parameter	Test Method	Acceptance Criteria	Engineering Runs		
				Run 1	Run 2	Run 3
Day 16	Sterility*	BacTAlert	No Growth	No growth	No growth	No growth
	Mycoplasma	PCR	Negative from Day 7 split	Negative	Negative	Negative
Day 22	Viability (%)	AOPI	≥ 70%	82.3%	85.13%	84.6%
	Total Viable Cells	AOPI	Report results	2.6 x 10 <sup>10</sup>	1 x 10 <sup>10</sup>	1.4 x 10 <sup>11</sup>
	Sterility	Gram Stain	Negative	Negative	Negative	Negative
	Sterility Final Product*	BacT/Alert	No Growth	Negative	Negative	Pending
	% CD45 <sup>+</sup> CD3 <sup>+</sup>	Flow cytometry	≥ 90%	99.3%	96.3%	99.8%
	Endotoxin	EndoSafe	≤ 0.7 EU/mL	<0.5 EU/mL	<0.5 EU/mL	<0.5 EU/mL
	Mycoplasma Final Product	PCR	Negative	Negative	Negative	Negative
Appearance	Visual Inspection	Intact bag with no visible clumps	Intact bag, no visible clumps	Intact bag, no visible clumps	Intact bag, no visible clumps	

\* Final sterility results for Day 16 and Day 22 are not available until after final product release for shipment. The gram stain results from Day 22 are used for sterility shipment release.

TABLE 12. Additional Functional Characterization: Measurement of IFN- $\gamma$  Secretion.

Functional Characterization	Method	Expected Results	Engineering Run		
			Run 1	Run 2	Run 3
IFN- $\gamma$ Stimulation with anti-CD3, CD28, CD137 (pg/million cells)	ELISA	>2 standard deviations over non-stimulated	3085 +/- 182	2363 +/- 437	pending
IFN- $\gamma$ Non-stimulated (pg/million cells)	ELISA	Not applicable	34 +/- 5	27 +/- 10	pending

**[00681]** In conclusion, the data from the engineering runs demonstrate that TIL drug product can be manufactured for the purpose of autologous administration to patients.

#### EXAMPLE 4: LYMPHODEPLETION

- 10 **[00682]** Cell counts can be taken at day 7 and prior to lymphodepletion. The final cell product included up to approximately  $150 \times 10^9$  viable cells formulated in a minimum of 50% HypoThermosol™ in Plasma-Lyte A™ (volume/volume) and up to 0.5% HSA

(compatible for human infusion) containing 300 IU/mL IL2. The final product was available for administration in one of two volumes for infusion:

- 1) 250 mL (in a 300-mL capacity infusion bag) when the total TIL harvested are  $\leq 75 \times 10^9$

5        OR

- 2) 500 mL (in a 600-mL capacity infusion bag) when the total TIL harvested are  $< 150 \times 10^9$

[00683] The total number of cells that could be generated for the final TIL infusion product for each patient due to patient-to-patient variation in T-cell expansion rates during the REP step cannot be predicted. A lower limit of cells on day 3, 4, 5, 6, 7 of the 3 to 14-day REP is set based on the minimum number of cells needed in order to make a decision to lymphodeplete the patient using the cyclophosphamide plus fludarabine chemotherapy regimen. Once we have begun lymphodepletion based on this minimal attained cell number, we are committed to treating the patient with the available number of TIL we generate in the REP by any of days 3 to 14, and in many cases day 7. The upper limit of the range for infusion ( $150 \times 10^9$  viable cells) is based on the known published upper limit safely infused where a clinical response has been attained. Radvanyi, et al., *Clin Cancer Res* **2012**, *18*, 6758-6770.

#### 20    **EXAMPLE 5: PROCESS 2A – DAY 0**

[00684] This example describes the detailed day 0 protocol for the 2A process described in Examples 1 to 4.

[00685] Preparation.

1. Confirmed Tumor Wash Medium, CM1, and IL-2 are within expiration date.
- 25    2. Placed CM1 (cell media 1) in incubator.

[00686] Method.

1. Cleaned the biological safety cabinet (BSC).
2. Set up in-process surveillance plates and left in biosafety cabinet for 1-2 hours during procedure.
- 30    3. Placed the TIL media CM1 in the biological safety cabinet.
4. Prepared TIL media CM1 containing 6000 IU/mL IL-2:
  - 4.1. 1L CM1

- 4.2. 1ml IL-2 (6,000,000 IU/mL)
- 4.3. Placed 25ml of CM1+IL2 into 50ml conical to be used for fragments when adding to G-REX .
- 4.4. Placed in 37 °C incubator to pre-warm
- 5 5. Wiped G-REX 100MCS package with 70% alcohol and place in biosafety cabinet. Closed all clamps except filter line.
6. Performed Acacia pump calibration.
7. Attached the red line of G-REX 100MCS flask to the outlet line of the acacia pump boot.
- 10 8. Attached pumpmatic to inlet line of pump boot and placed in bottle with media. Released clamps to pump boot.
9. Pumped remaining 975 ml of pre-warmed CM1 containing 6,000 IU/ml of IL-2 in each G-REX 100MCS bioreactor.
10. Heated seal red line, disconnect from pump boot.
- 15 11. Placed label on G-REX .
12. Placed G-REX 100MCS in incubator until needed.

**[00687] Tissue Dissection**

1. Recorded the start time of tumor processing.
2. Transferred Tumor Wash Medium to BSC.
- 20 3. Placed 5 100 mm petri dishes in biosafety cabinet, 3 for washes, 1 for holding and 1 for unfavorable tissue. Labeled dishes accordingly. Unfavorable tissue was indicated by yellow adipose tissue or necrotic tissue.
4. Placed three 6 well plates into biosafety cabinet.
5. Pipetted 3-5 mL of Tumor Wash Medium into each well of one six well plates for excess tumor pieces.
- 25 6. Pipetted 50 mL of Tumor Wash Medium to wash dishes 1-3 and holding dish.
7. Placed two 150 mm dissection dishes into biosafety cabinet.
8. Placed 3 sterile 50 mL conical tubes into the BSC.
9. Labeled one as forceps tumor wash medium, the second as scalpel tumor wash medium, and third for Tumor wash medium used in for lid drops.
- 30 10. Added 5-20 mL of tumor wash medium to each conical. The forceps and scalpels were dipped into the tumor wash media as needed during the tumor washing and dissection process.
11. Placed scapel and forceps in appropriate tubes.
- 35 12. Using long forceps removed the tumor(s) from the Specimen bottle and transferred to the Wash 1 dish.
13. Incubated the tumor at ambient in the Wash 1 dish for  $\geq 3$  minutes.
14. During the incubation, re-labeled the Specimen bottle "Bioburden" and stored at 2-8 °C until the final harvest or further sterility testing is required.
- 40 15. Using forceps transferred the tumor to the Wash 2 dish.
16. Incubated the tumor at ambient in the Wash 2 dish for  $\geq 3$  minutes.

17. During the incubation, using a transfer pipette, added approximately 4 evenly-spaced, individual drops of Tumor Wash Medium to each circle of the 6 well plate lids designated as Tumor Fragments dishes.
18. Using forceps transferred the tumor to the Wash 3 dish.
- 5 19. Incubated the tumor at ambient in the Wash 3 dish for  $\geq 3$  minutes.
20. The 150 mm dish lid was used for dissection. Placed a ruler underneath.
21. Using forceps transferred the tumor to the Dissection dish, measured and recorded the length of the tumor.
22. Took photograph of tumor.
- 10 23. Performed an initial dissection of the tumor pieces in the Dissection dish into intermediate pieces taking care to conserve the tumor structure of each intermediate piece.
24. Transferred any intermediate tumor pieces not being actively dissected into fragments to the tissue holding dish to ensure the tissue remained hydrated during the entire dissection procedure.
- 15 25. Worked with one intermediate tumor piece at a time, carefully sliced the tumor into approximately  $3 \times 3 \times 3$  mm fragments in the Dissection Dish, using the ruler underneath the dish for reference.
- 20 26. Continued dissecting fragments from the intermediate tumor piece until all tissue in the intermediate piece had been evaluated.
27. Selected favorable fragments and using a transfer pipette transferred up to 4 favorable fragments into the wash medium drops in one circle in the Tumor Fragments dish. Using a transfer pipette scalpel or forceps, transferred, as much as possible of the unfavorable tissue and waste product to the Unfavorable Tissue dish to clear the dissection dish. All remaining tissue was placed into one of the wells of the six-well plate. (Unfavorable tissue was indicated by yellow adipose tissue or necrotic tissue.)
- 25 28. Continued processing by repeating step 23- 26 for the remaining intermediate tumor pieces, working one intermediate piece at a time until the entire tumor had been processed. (Obtained a fresh scalpel or forceps as needed, to be decided by processing technician.)
- 30 29. Moved fragment plates toward rear of hood.
30. Using transfer pipette, the scalpel, or the forceps, transferred up to 50 of the best tumor fragments to the 50 mL conical tube labeled tumor fragments containing the CM1.
- 35 31. Removed floaters from 50 mL conical with transfer pipette. Recorded number of fragments and floaters.
32. Removed all unnecessary items from hood, retaining the favorable tissue plates if they contain extra fragments. Wiped hood with alcohol wipe.
33. Removed G-REX 100MCS from incubator, wipe with 70% alcohol and place in biosafety cabinet.
- 40 34. Swirled conical with tumor fragments and poured the contents on the 50ml conical into the G-Rex 100MCS flask

35. If one or more tumor fragments transferred to the G-Rex 100M flask float, obtained one additional tumor fragment when available from the Favorable Tissue Dish and transfer it to the G-Rex 100M flask.
36. Recorded incubator # (s) and total number of fragments added to each flask.
- 5 37. Placed the G-REX 100M bioreactor in 37 °C, 5% CO<sub>2</sub> incubator
38. Any unused tumor were placed in 100 mL of HypoThermosol and delivered to the laboratory.
39. Recorded the stop time of tumor processing.
- 10 40. Discarded any un-used TIL complete media containing IL-2 and any un-used aliquots of IL-2.
41. Cleaned biological safety cabinet.
42. Placed the Bioburden sample in the proper storage conditions.
43. Recorded data.
- 15 44. Saved the picture as file specimen ID#Tumor process Date to the prepared patient's file.
45. Ordered and ensured delivery of settle plates to the microbiology lab.

#### **EXAMPLE 6: PROCESS 2A – DAY 11**

20 **[00688]** This example describes the detailed day 11 protocol for the 2A process described in Examples 1 to 4.

**[00689]** Prior Preparation.

1. Day before processing:
  - 1.1. CM2 could be prepared the day before processing occurred. Place at 4°C.
- 25 2. Day of processing.
  - 2.1. Prepared the feeder cell harness.
    - 2.1.1. Closed all clamps on a CC2 and 4S-4M60 connector sets.
    - 2.1.2. Sterile welded 4 spikes of 4S-4M60 harness to the spike line on the CC2 removing the spike.
    - 2.1.3. Set aside for feeder cell pooling.
  - 30 2.2. Prepared 5 mL of cryopreservation media per CTF-FORM-318 and place at 4°C until needed.

**[00690]** Clean Room Environmental Monitoring - Pre-Processing

1. Recorded clean room information.
- 35 2. Biosafety Cabinets (BSC) were cleaned with large saturated alcohol wipes or alcohol spray.
3. Verified Particle Counts for 10 minutes before beginning processing.
4. Set up in-process surveillance plates and left in biosafety cabinet for 1-2 hours during procedure.

**[00691]** Prepare G-Rex 500MCS Flask:

1. Using 10 mL syringe aseptically transferred 0.5mL of IL-2 (stock is  $6 \times 10^6$  IU/mL) for each liter of CM2 (cell media 2) into the bioprocess bag through an unused sterile female luer connector.
- 5 2. Used excess air in the syringe to clear the line, drew up some media from the bag and expel back into bag. This ensured all the IL-2 has been mixed with the media. Mixed well.
3. Opened exterior packaging and place G-Rex 500MCS in the BSC. Closed all clamps on the device except large filter line.
- 10 4. Sterile welded the red harvest line from the G-Rex 500MCS to the pump tubing outlet line.
5. Connected bioprocess bag female luer to male luer of the Pump boot.
6. Hung the bioprocess bag on the IV pole, opened the clamps and pump 4.5 Liters of the CM2 media into the G-Rex 500MCS. Cleared the line, clamp, and heat seal.
- 15 7. Retained the line from pump to media. It was used when preparing feeder cells.
8. Placed G-Rex 500MCS in the incubator.

**[00692]** Prepare Irradiated Feeder Cells

1. Sealed and removed spike(s) from IL TP. Clamped both lines.
- 20 2. Recorded the dry weight of a 1L transfer pack (TP).
3. Sterile welded the 1L transfer pack to the acacia pump boot ~12" from bag.
4. The other end of the pump tubing was still connected to the 10L labtainer.
5. Pumped 500mL CM2 by weight into the TP.
6. Closed clamp and sealed close to weld joint.
- 25 7. Placed in incubator.
8. Verified and Logged out feeder cell bags.
9. Recorded feeder lot used.
10. Wiped bags with alcohol.
11. Placed in zip lock bags.
- 30 12. Thawed feeder cells in the 37° C (+/- 1° C) water bath. Recorded temperature of water bath.
13. Removed and dried with gauze.
14. Passed feeder cells through pass thru into Prep Room.
15. Transferred to BSC in Clean Room.
- 35 16. Using the previously prepared feeder harness, welded the 1L TP with media to one of the unused lines on the sample port side of the 3 way stopcock as close as possible to the seal junction losing as little tubing as possible.
17. Put feeder harness into BSC.
18. Spiked each of the 3 feeder bags with the spike from the feeder harness into the single
- 40 port of the feeder bag.
19. Rotated the stopcock valve so the 1L TP is in the "OFF" position.

20. Working with one bag at a time, opened the clamps on the line to the feeder bag, expel air in syringe and draw the contents of the feeder bag into the syringe. Expelled air from syringe helped in recovering cells. Closed clamp to feeder bag.
21. Recorded the volume recovered of thawed feeder cells in each bag.
- 5 22. Rotated the stopcock valve so that the feeder bag is in the "OFF" position
23. Opened the clamp on the TP and dispense the contents of the syringe into the TP.
24. Ensured the line has been cleared and re-clamp the TP. You may have had to draw some air into syringe from TP for use in clearing the line.
25. Mixed the cells well.
- 10 26. Closed clamp to feeder bag.
27. Rotated stopcock so syringe port is in the "OFF" position. Disconnected the 60mL syringe from the stopcock.
28. Replaced with new syringe for each feeder bag.
29. Left syringe on after final bag.
- 15 30. Mixed final feeder formulation well.
31. Rotated stopcock so feeder cell suspension is in the "OFF" position.
32. Mixed cells cell and using a 5 mL syringe and needless port, rinsed port with some cell solution to ensure accurate sampling and remove 1ml of cells, placed into tube labeled for counting.
- 20 33. Repeated with second syringe. These two independent samples each had a single cell count performed.
34. Turned stopcock so feeder suspension is in the "OPEN" position and using the 60ml syringe attached to harness expelled air into the TP to clear the line.
35. Removed syringe and covered luer port with a new sterile cap.
- 25 36. Heated seal the TP close to weld joint, removed the harness.
37. Recorded mass of transfer pack with cell suspension and calculated the volume of cell suspension.
38. Placed in incubator.
39. Performed a single cell counts on the feeder cell sample and record data and attach counting raw data to batch record.
- 30 40. Documented the Cellometer counting program.
41. Verified the correct dilution was entered into the Cellometer.
42. Calculated the total viable cell density in the feeder transfer pack.
43. If cell count was  $< 5 \times 10^9$ , thawed more cells, count, and added to feeder cells.
- 35 44. Re-weighed feeder bag and calculated volume.
45. Calculated volume of cells to remove.

#### [00693] Addition of Feeder to G-REX

1. Sterile welded a 4" transfer set to feeder TP.
- 40 2. In the BSC attached an appropriately sized syringe to the female luer welded to the feeder transfer pack.

3. Mixed cells well and removed the volume calculated in step 40 or 41 to achieve  $5.0 \times 10^9$  cells. Discarded unneeded cells.
  4. Using a 1mL syringe and 18G needle draw up 0.150mL of OKT3, removed needle and transferred to the feeder TP through the female luer.
  - 5 5. Rinsed tubing and syringe with feeder cell and mixed bag well. Cleared the line with air from syringe.
  6. Removed the G-Rex 500MCS from the incubator, wiped with alcohol wipes and placed beside the SCD.
  7. Sterile welded the feeder bag to the red line on the G-Rex 500MCS. Unclamped the line and allowed the feeder cells to flow into the flask by gravity.
  - 10 8. Ensured the line has been completely cleared then heat sealed the line close to the original weld and removed the feeder bag.
  9. Returned the G-Rex 500MCS to the incubator and recorded time.
- 
- 15 **[00694]** Prepare TIL: record time initiation of TIL harvest
    1. Carefully removed G-Rex 100MCS from incubator and closed all clamps except large filter line.
    2. Welded a 1L transfer pack to the redline on the G-REX 100MCS.
    3. Closed clamp on a 300ml TP. Heat seal ~12 inches from the bag removing the spike.
    - 20 Recorded dry weight/mass.
    4. Sterile welded the 300mL transfer pack to the cell collection line on the 100MCS close to the heat seal. Clamped the line.
    5. Released all clamps leading to the 1L TP.
    6. Using the GatheRex transferred ~900mL of the culture supernatant to the 1L transfer pack. Gatherex stopped when air entered the line. Clamped the line and heat seal.
    - 25 7. Swirled the flask until all the cells had been detached from the membrane. Checked the membrane to make sure all cells are detached.
    8. Tilted flask away from collection tubing and allowed tumor fragments to settle along edge.
    - 30 9. Slowly tipped flask toward collection tubing so fragments remain on opposite side of flask.
    10. Using the GatheRex transferred the residual cell suspension into the 300mL transferred pack avoiding tumor fragments.
    11. Rechecked that all cells had been removed from the membrane.
    - 35 12. If necessary, back washed by releasing clamps on GatheRex and allowed some media to flow into the G-Rex 100MCS flask by gravity.
    13. Vigorously tapped flask to release cells and pumped into 300ml TP.
    14. After collection was complete, closed the red line and heat seal.
    - 40 15. Heated seal the collection line leaving roughly the same length of tubing as when dry weight was recorded.

16. Recorded mass (including dry mass) of the 300ml TP containing the cell suspension and calculated the volume of cell suspension.
17. In the BSC spike the 300mL TP with a 4" plasma transferred set. Mixed cells well. Aseptically attached a 5mL syringe draw 1mL, placed in cryo vial. Repeated with second syringe. These were used for cell counting, viability.
18. Re-clamped and replaced luer cap with new sterile luer cap.
19. Placed in incubator and recorded time place in incubator.
20. Performed a single cell count on each sample and recorded data and attach counting raw data to batch record.
21. Documented the Cellometer counting program.
22. Verified the correct dilution was entered into the Cellometer.
23. If necessary adjusted total viable TIL density to  $\leq 2 \times 10^8$  viable cells.
24. Calculated volume to remove or note adjustment not necessary.
25. In the BSC aseptically attached an appropriately sized syringe to the 300mL TP.
26. If required, removed the calculated volume of cells calculated in the "Calculate volume to remove" table.
27. Clamped and heat sealed the 300ml TP.
28. Transferred excess cells to an appropriately sized conical tube and placed in the incubator with cap loosened for later cryopreservation.
29. Removed the G-Rex 500MCS from the incubator and place beside the SCD.
30. Sterile welded the 300ml TP to the inlet line of the Acacia pump.
31. Sterile welded the red line of the G-Rex 500MCS to the outlet line of the Acacia pump.
32. Pumped cells into flask.
33. Ensured the line has been completely cleared then heat sealed the red line close to the original weld.
34. Checked that all clamps on the G-Rex 500MCS were closed except the large filter line.
35. Returned the G-Rex 500MCS to the incubator and record the time placed in the G-Rex incubator.
36. Ordered and ensured delivery of settle plates to the microbiology lab.

#### Cryopreservation of Excess

[00695] Calculated amount of freezing media to add to cells:

TABLE 13: Target cell concentration was  $1 \times 10^8$ /ml

A. Total cells removed (from step 15)	mL
B. Target cell concentration	$1 \times 10^8$ cells/mL
Volume of freezing media to add (A/B)	mL

37. Spun down TIL at 400 x g for 5 min at 20°C with full brake and full acceleration.
38. Aseptically aspirated supernatant.
39. Gently tapped bottom of tube to resuspend cells in remaining fluid.

40. While gently tapping the tube slowly added prepared freezing media.
41. Aliquoted into appropriate size cryo tubes and record time cells placed into -80°C.

#### EXAMPLE 7: PROCESS 2A – DAY 16

5 [00696] This example describes the detailed day 16 protocol for the 2A process described in Examples 1 to 4.

[00697] Clean Room Environmental Monitoring - Pre-Processing.

1. Biosafety Cabinets were cleaned with large saturated alcohol wipes or alcohol spray.
2. Verified Particle Counts for 10 minutes before beginning processing.
- 10 3. Set up in-process surveillance plates and left in biosafety cabinet for 1-2 hour during procedure.

[00698] Harvest and Count TIL.

- 15 1. Warmed one 10L bag of CM4 for cultures initiated with less than  $50 \times 10^6$  TIL in a 37°C incubator at least 30 minutes or until ready to use.
2. In the BSC aseptically attached a Baxter extension set to a 10 L Labtainer bag.
3. Removed the G-Rex 500MCS flask from the incubator and placed on the benchtop adjacent the GatheRex. Checked all clamps were closed except large filter line. Moved the clamp on the quick connect line close to the “T” junction.
- 20 4. Sterile welded a 10L Labtainer to the red harvest line on the G-Rex 500MCS via the weldable tubing on the Baxter extension.
5. Heat sealed a 2L transfer pack 2” below the “Y removing the spike and recorded dry weight. Sterile welded the 2L TP to the clear collection line on the G-Rex 500MCS.
- 25 6. Set the G-Rex 500MCS on a level surface.
7. Unclamped all clamps leading to the 10L Labtainer and using the GatheRex transferred ~4L of culture supernatant to the 10L Labtainer.
8. Harvested according to appropriate GatheRex harvesting instructions.
9. Clamped the red line and recorded time TIL harvest initiated.
10. GatheRex stopped when air entered the line. Clamped the red line.
- 30 11. After removal of the supernatant, swirled the flask until all the cells had been detached from the membrane. Tilted the flask to ensure hose was at the edge of the flask.
12. Released all clamps leading to the 2L TP and using the GatheRex transfer the residual cell suspension into the 2L TP maintaining the tilted edge until all cells were
- 35 13. Inspected membrane for adherent cells.
14. If necessary, back washed by releasing clamps on red line and allowed some media to flow into the flask by gravity.
15. Closed the red line and triple heat seal.

16. Vigorously tapped flask to release cells.  
 17. Added cells to 2L TP.  
 18. Heated seal the 2 L transfer pack leaving roughly the same length of tubing as when dry weight was recorded.  
 5 19. Retained G-Rex 500MCS, it was reused in the split.  
 20. Recorded mass of transfer pack with cell suspension and calculated the volume of cell suspension.  
 21. Determined cell suspension volume, including dry mass.  
 22. Sterile welded a 4" transfer set to the cell suspension bag.  
 10 23. In the BSC mixed the cells gently and with 20cc syringe draw up 11ml and aliquoted as shown in Table 14:

TABLE 14. Testing parameters.

Test	Sample volume	Vessel
Cell Count and viability	2- 2mL samples	Cryovials
Mycoplasma	1 mL	Cryovial stored at 4 °C until testing completed.
Sterility	1 mL	Inoculated 0.5mL into one each anaerobic and aerobic culture bottles
Flow	2 – 2mL	Unused cell count (Cryopreserved for future batch testing)
Remainder of cells		Discarded

24. Heat sealed. Closed the luer connection retaining the clamp  
 25. Labeled and placed the cell suspension in the incubator and recorded time placed in  
 15 the incubator.  
 26. Calculated new volume.  
 27. Recorded Volume in 2 L transfer pack based on volume of cell suspension and volume removed for QC (11 mL).  
 28. Inoculated and ordered sterility testing.  
 20 29. Stored the mycoplasma sample at 4°C in the pending rack for mycoplasma testing.  
 30. Set aside until TIL was seeded.

[00699] Cell Count:

- [00700] Performed single cell counts and recorded data and attach counting raw data to batch record. Documented Dilution. Documented the Cellometer counting program. Verified  
 25 the correct dilution was entered into the Cellometer.

**[00701]** Method continued:

31. Calculated the total number of flasks required for subculture

\*\*Re-used the original vessel and rounded fractions of additional vessels up.

**[00702]** IL-2 addition to CM

- 5 1. Placed 10L bag of Aim V with Glutamax in the BSC.
2. Spiked the media bag with a 4" plasma transfer set.
3. Attached an 18G needle to a 10mL syringe and draw 5mL of IL-2 into the syringe (final concentration is 3000 IU/ml).
- 10 4. Removed the needle and aseptically attach the syringe to the plasma transfer set and dispensed IL-2 into the bag.
5. Flushed the line with air, draw up some media and dispense into the bag. This insured all IL-2 is in the media.
6. Repeated for remaining bags of Aim V.

**[00703]** Prepare G-REX500MCS Flasks

- 15 1. Determined amount of CM4 to add to flasks. Recorded volume of cells added per flask and volume of CM4 5000mL-A.
2. Closed all clamps except the large filter line.
3. Sterile welded the inlet line of the Acacia pump to the 4" plasma transfer set on the media bag containing CM4.
- 20 4. Sterile welded the outlet line of the pump to the G-Rex 500MCS via the red collection line.
5. Pump determined amount of CM4 into the G-Rex 500MCS using lines on flask as guide.
6. Heated seal the G-Rex 500MCS red line.
- 25 7. Repeated steps 4-6 for each flask. Multiple flasks could be filled at the same time using gravity fill or multiple pumps. A "Y" connector could be welded to the outlet line of the pump and the two arms welded to two G-Rex 500MCS flasks filling both at the same time.
8. Placed flasks in a 37°C, 5% CO<sub>2</sub>.

**[00704]** Seed Flasks With TIL

1. Closed all clamps on G-Rex 500MCS except large filter line
2. Sterile welded cell product bag to inlet line of the Acacia pump.
3. Sterile welded the other end of the pump to the red line on the G-Rex 500MCS.
4. Placed pump boot in pump.
- 35 5. Placed the cell product bag on analytical balance and recorded time TIL added to G-REX flask.
6. Zeroed the balance.

7. Unclamped lines and pump required volume of cells into G-Rex 500MCS by weight assuming 1g=1mL.
8. Turned cell bag upside down and pump air to clear the line. Heated seal red line of G-Rex 500MCS. Placed flask in incubator.
- 5 9. Sterile welded the outlet line of the pump to the next G-Rex 500MCS via the red collection line
10. Mixed cells well.
11. Repeated cell transfer for all flasks.
12. Placed flasks in a 37°C, 5% CO<sub>2</sub> and recorded time TIL added to G\_REX flask.
- 10 13. Ordered testing for settle plates to the microbiology lab.
14. Recorded accession numbers.
15. Ordered testing for aerobic and anaerobic sterility.
16. Ensured delivery of plates and bottles to the microbiology lab.

**[00705] Cryopreservation of Flow or Excess Cells:**

- 15 1. Calculated amount of freezing media required:
  - a. Target cell concentration was  $1 \times 10^8$ /ml; record total cells removed. Target cell concentration was  $1 \times 10^8$  cells/mL. Calculated total volume of freezing media to add.
2. Prepared cryo preservation media and placed at 40°C until needed.
- 20 3. Spun down TIL at 400 x g for 5 min at 20°C with full brake and full acceleration.
4. Aseptically aspirated supernatant.
5. Gently tapped bottom of tube to resuspend cells in remaining fluid.
6. While gently tapping the tube slowly added prepared freezing media.
7. Aliquoted into appropriate sized labelled cryo tubes.
- 25 8. Placed vial in a Mr. Frosty or equivalent and placed in a -80°C freezer.
9. Within 72 hours transferred to permanent storage location and documented and recorded date and time placed in -80°C freezer.

**EXAMPLE 8: PROCESS 2A – DAY 22**

- 30 **[00706]** This example describes the detailed day 22 protocol for the 2A process described in Examples 1 to 4.

**[00707] Document Negative In-Process Sterility Results**

- [00708]** Before beginning harvest, obtained the Day 16 preliminary sterility results from Microbiology lab. Contacted the Laboratory Director or designee for further instructions if
- 35 the results were positive.

**[00709] Clean Room Environmental Monitoring - Pre-Processing**

1. Verified Particle Counts for 10 minutes before beginning processing.
2. Biosafety Cabinets were cleaned with large saturated alcohol wipes or alcohol spray.
3. Set up in-process surveillance plates and left in biosafety cabinet for 1-2 hour during procedure.

#### 5 [00710] Advanced Preparation

1. In BSC aseptically attached a Baxter extension set to a 10L labtainer bag or equivalent. Label LOVO filtrate bag.
2. Placed three 1L bags of PlasmaLyte A in the BSC
3. Prepared pool and labeled the PlasmaLyte A bags with 1% HSA:
  - 10 3.1. Closed all clamps on a 4S-4M60 Connector set and spiked each of the PlasmaLyte bags.
  - 3.2. Welded one of the male ends of the 4S-4M60 to the inlet line of the Acacia pump boot.
  - 15 3.3. Welded the outlet line of the pump boot to a 3 liter collection bag. Closed all clamps on 3L bag except the line to pump.
  - 3.4. Pumped the 3 liters of Plasmalyte into the 3 liter bag. If necessary removed air from 3L bag by reversing the pump.
  - 3.5. Closed all clamps except line with female luer.
  - 20 3.6. Using two 100 mL syringes and 16-18G needles, load 120 mL of 25% HSA. Red capped syringes.
  - 3.7. Attached one syringe to the female luer on the 3 liter bag and transferred HSA to 3L PlasmaLyte bag. Mix well.
  - 3.8. Repeated with second syringe.
  - 3.9. Mixed well.
  - 25 3.10. Closed all clamps.
  - 3.11. Using a 10mL syringe, removed 5 mL of PlasmaLyte with 1%HSA from the needleless port on the 3 liter bag.
  - 3.12. Capped syringe and kept in BSC for IL-2 dilution.
  - 3.13. Closed all clamps.
  - 30 3.14. Heated seal removing the female luer line from the pump boot.
  - 3.15. Labeled LOVO Wash buffer and date. Expired within 24 hrs at ambient temperature.

#### [00711] IL-2 Preparation

- 35 1. Dispensed Plasmalyte/1%HSA from 5 mL syringe into a labeled 50 ml sterile conical tube.
2. Added 0.05mL IL-2 stock to the tube containing PlasmaLyte.
3. Labeled IL-2  $6 \times 10^4$
4. Capped label and store at 2-8°C. Record volumes.

#### 40 [00712] Preparation of Cells

1. Closed all clamps on a 10 L Labtainerbag. At Attach Baxter extension set to the 10L bag via luer connection.
2. Removed the G-REX 500M flasks from the 37°C

3. Sterile welded the red media removal line from the G-Rex 500MCS to the extension set on the 10L bioprocess bag.
4. Sterile welded the clear cell removal line from the G-Rex 500MCS to a 3L collection bag and labeled "pooled cell suspension".
5. Unclamped red line and 10L bag.
6. Used the GatherRex pump, volume reduced the first flask.  
Note: If an air bubble was detected then the pump could stop prematurely. If full volume reduction was not complete reactivated GatherRex pump.
7. Closed the clamp on the supernatant bag and red line.
8. Swirled the G-REX 500M flask until the TIL were completely resuspended while avoiding splashing or foaming. Made sure all cells have been dislodged from the membrane.
9. Opened clamps on clear line and 3L cell bag.
10. Tilted the G-Rex flask such that the cell suspension was pooled in the side of the flask where the collection straw was located.
11. Started GatherRex to collect the cell suspension. Note: If the cell collection straw was not at the junction of the wall and bottom membrane, rapping the flask while tilted at a 45° angle was usually sufficient to properly position the straw.
12. Ensured all cells had been removed from the flask.
13. If cells remained in the flask, added 100mL of supernatant back to the flask, swirled, and collected into the cell suspension bag.
14. Closed clamp on the line to the cell collection bag. Released clamps on GatherRex.
15. Heated seal clear line of G-Rex 500MCS.
16. Heated seal red line of G-Rex 500MCS.
17. Repeated steps 3-16 for additional flasks.
18. It was necessary to replace 10L supernatant bag as needed after every 2nd flask.
19. Multiple GatherRex could be used.
20. Documented number of G-Rex 500MCS processed.
21. Heated seal cell collection bag. Recorded number of G-REX harvested.
22. With a marker made a mark ~2" from one of the female luer connectors on a new 3 liter collection bag.
23. Heated seal and removed the female luer just below the mark.
24. Labeled as LOVO Source Bag
25. Recorded the dry weight.
26. Closed all clamps of a 170 µm blood filter.
27. Sterile welded the terminal end of the filter to the LOVO source bag just below the mark.
28. Sterile welded a source line of the filter to the bag containing the cell suspension.
29. Elevated the cell suspension by hanging cells on an IV pole to initiate gravity-flow transfer of cells. (Note: Did not allow the source bag to hang from the filtration apparatus.)
30. Opened all necessary clamps and allow TIL to drain from the cell suspension bag through the filter and into the LOVO source bag.

31. Once all cells were transferred to the LOVO source bag, closed all clamps, heated seal just above the mark and detached to remove filter.
32. Mixed bag well and using a two 3mL syringe take 2 independent 2 mL samples from the syringe sample port for cell counting and viability.
- 5 33. Weighed the bag and determined the difference between the initial and final weight.
34. Recorded data and place in incubator, including dry mass.

**[00713]** Cell Count.

**[00714]** Performed a single cell count on each sample and recorded data and attach counting raw data to batch record. Documented the Cellometer counting program. Verified the  
10 correct dilution was entered into the Cellometer. Determined total number of nucleated cells. Determined number of TNC to remove to retain =  $1.5 \times 10^{11}$  cells for LOVO processing. Place removed cell into appropriate size container for disposal.

**[00715]** LOVO Harvest

**[00716]** The 10L Labtainer with Baxter extension set in Prior Preparation was the  
15 replacement filtrate bag welded to the LOVO kit later on. Turned LOVO on and follow the screen displays.

**[00717]** Check weigh scales and pressure sensor

**[00718]** To access the *Instrument Operation Profile*:

1. Touched the information button.
- 20 2. Touched the instrument settings tab.
3. Touched the Instrument Operation Profile button.
4. The Instrument Operation Profile displayed.

**[00719]** Check the weigh scales

1. Made sure there was nothing hanging on any of the weigh scales and reviewed the  
25 reading for each scale.
2. If any of the scales read outside of a range of 0 +/- 2 g, performed weigh scale calibration as described in the Weigh Scale Calibration Manual from the manufacturer.
3. If all scales were in tolerance with no weight hanging, proceed to hang a 1-kg  
30 weight on each scale (#1-4) and reviewed the reading.
4. If any of the scales read outside of a range of 1000 +/- 10 g when a 1-kg weight was hanging, performed weigh scale calibration as described in the LOVO Operator's Manual from the manufacturer.

**[00720]** Check the pressure sensor

1. Reviewed the pressure sensor reading on the Instrument Operation Profile Screen.
2. N/A: If the pressure sensor reading was outside 0 +/- 10 mmHg, stored a new atmospheric pressure setting in Service Mode as described in the LOVO Operator's Manual from the manufacturer.
- 5       a. Touched the check button on the *Instrument Operation Profile screen*.
- b. Touched the check button on the *Instrument Settings tab*.
3. If weigh scale calibration had been performed or a new atmospheric pressure setting had been stored, repeated the relevant sections.

10 [00721] To start the procedure, selected the "TIL G-Rex Harvest" protocol from the drop-down menu on the Protocol Selection Screen and press Start.

1. The Procedure Setup Screen displayed.
2. Touched the Solutions Information button.
3. The Solution 1 Screen displayed. Review the type of wash buffer required for Solution 1. (Should read PlasmaLyte.)
- 15 4. Touched the Next button to advance to the Solution 2 Screen. Reviewed the type of wash buffer required for Solution 2. (Should read "NONE", indicating that the protocol had been configured to only use one type of wash buffer, which was PlasmaLyte)
- 20 5. Touched the check button on the Solution 2 Information Screen to return to the Procedure Setup screen.
6. Touched the Procedure Information Button.
7. The Procedure Information Screen displayed.
8. Touched the User ID entry field. A keypad will display. Entered the initials of the performer and verifier. Touched the button to accept the entry.
- 25 9. Touched the Source ID entry field. A keypad will display. Entered the product lot #. Touched the button to accept the entry.
10. Touched the Procedure ID entry field. A keypad will display. Entered "TIL Harvest". Touched the button to accept the entry.
- 30 11. If there are extra notes to record, touched the Procedure Note entry field. A keypad displayed. Entered any notes. Touched the button to accept the entry.

**NOTE: The Procedure Note entry field is optional and can be left blank.**

12. Touched the check button on the Procedure Information Screen to return to the Procedure Setup Screen.
- 35 13. Verified that a "check" displays in the Procedure Information button. If no "check" displays, touched the Procedure Information button again and ensured that the User ID, Source ID, and Procedure ID fields all had entries.
14. Touched the Parameter Configuration Button.
15. The General Procedure Information Screen displayed.
- 40 16. Touched the Source Volume (mL) entry field. A numeric keypad displayed. Entered the Calculated volume of cell suspension (mL) from Table 1

- 17. Touched the button to accept the entry.
- 18. Touched the Source PCV (%) entry field. The TIL (viable+dead) screen displays.
- 19. Touched the Cell Concentration entry field. A numeric keypad displayed. Entered the Total Cellular concentration/mL from Table 14 in the Source product in units of “x 10<sup>6</sup>/mL”. The entry could range from 00.0 to 99.9. Touched the button to accept the entry and return to the General Procedure Information Screen. NOTE: After the Cell Concentration was accepted, the Source PCV (%) entry field on the General Procedure Information Screen displayed the PCV % calculated by the LOVO, based on the Cell Concentration entry made by the operator.
- 20. On the General Procedure screen, touched the Next button to advance to screen 4 of 8, the Final Product Volume (Retentate Volume) screen. Note: Screens 2 and 3 did not have any entry fields for the operator to fill in.
- 21. The Final Product Volume (Retentate Volume) screen displayed.
- 22. Using the Total nucleated cells (TNC) value from Table 15, determined the final product target volume in the table below (Table 16). Entered the Final Product Volume (mL) associated with that Cell Range during LOVO Procedure setup.

TABLE 15. Determination of Final Product Target Volume.

Cell Range	Final Product (Retentate) Volume to Target (mL)
$0 < \text{Total (Viable + Dead) Cells} \leq 7.1\text{E}10$	150
$7.1\text{E}10 < \text{Total (Viable + Dead) Cells} \leq 1.1\text{E}11$	200
$1.1\text{E}11 < \text{Total (Viable + Dead) Cells} \leq 1.5\text{E}11$	250

TABLE 16. Product target volume.

Total nucleated cells (TNC) x10 <sup>6</sup>	Final Product (Retentate) Target Volume (mL)

- 23. To target the specified volume from Table 16 touched the Final Product Volume (mL) entry field. A numeric keypad displayed. Entered the desired Final Product Volume in unit of mL. Touched the button to accept the entry.
- 24. Touched on the Final Product Volume (Retentate Volume) screen to return to the Procedure Setup Screen. Note: Screens 5-8 did not have any entry fields for the operator to fill in.
- 25. Verified that a “Check” displays in the Parameter Configuration button. If no “check” displays, touched the Procedure Information button again and ensured

that Source Volume and Source PCV on page 1 have entries. Also ensured that either the Target Minimum Final Product Volume checkbox was checked OR the Final Product Volume (mL) field had an entry on page 4.

26. Touched the Estimate Button at the top right corner of the screen.
- 5 27. The Estimation Summary Screen displayed. Confirmed sufficient and accurate values for Source and PlasmaLyte Wash Buffer.
28. Loaded the disposable kit: Followed screen directions for kit loading by selecting help button “(?)”.
- 10 29. Made a note of the volumes displayed for Filtrate and Solution 1 (read PlasmaLyte)
30. Made a note of the volumes displayed for Filtrate and Solution 1 (read PlasmaLyte).
31. For instructions on loading the disposable kit touched the help button or followed instructions in operators manual for detailed instructions.
- 15 32. When the standard LOVO disposable kit had been loaded, touched the Next button. The Container Information and Location Screen displays. Removed filtrate bag from scale #3.
33. For this protocol, the Filtrate container was New and Off Scale
- 20 34. If the Filtrate container was already shown as New and Off-Scale, no changes were made.
35. If the Filtrate container type was shown as Original, touched the Original button to toggle to New.
36. If the Filtrate location was shown as On-Scale, touched the On-Scale button to toggle to Off-Scale.
- 25 37. If the volume of Filtrate to be generated was  $\leq 2500$  mL, the Filtrate Container Location was shown as On-Scale For consistency among runs, the Filtrate Container Location was changed to Off-Scale and container type was “new”.
38. Touched the On-Scale button to toggle to Off-Scale. Attached transfer set Use sterile welding technique to replace the LOVO disposable kit Filtrate container
- 30 with a 10-L bag. Opened the weld.
39. Placed the Filtrate container on the benchtop. Did NOT hang the Filtrate bag on weigh scale #3. Weigh scale #3 was empty during the procedure.
40. Opened any plastic clamps on the tubing leading to the Filtrate container. NOTE: If the tubing was removed from the F clamp during welding, replaced in clamp.
- 35 41. Touched the Filtrate Container Capacity entry field. A numeric keypad displayed. Entered the total new Filtrate capacity (10,000 mL). Touched the “check” button to accept the entry.
42. Used sterile welding technique to replace the LOVO disposable kit Filtrate container with a 10-L bag. Opened the weld. Note: If tubing was removed from
- 40 the F clamp during welding, replaced in clamp.
43. Placed the new Filtrate container on the benchtop. Did NOT hang the Filtrate bag on weigh scale #3. Weigh scale #3 was empty during the procedure
44. Opened any plastic clamps on the tubing leading to the Filtrate container.

45. For the Retentate container, the screen displayed Original and On-Scale.
46. No changes were made to the Retentate container.
47. When all changes were made to the Filtrate container and appropriate information entered, touched the Next button.
- 5 48. The Disposable Kit Dry Checks overlay displays. Checked that the kit had been loaded properly, then pressed the Yes button.
49. All LOVO mechanical clamps closed automatically and the Checking Disposable Kit Installation screen displayed. The LOVO went through a series of pressurizing steps to check the kit.
- 10 50. After the disposable kit check passed successfully, the Connect Solutions screen displayed.
51. 3L was the wash volume. Entered this value on screen.
52. Used sterile welding technique to attach the 3-L bag of PlasmaLyte to the tubing passing through Clamp 1. Opened the weld.
- 15 53. Hung the PlasmaLyte bag on an IV pole,
54. Opened any plastic clamps on the tubing leading to the PlasmaLyte bag.
55. Verified that the Solution Volume entry is 3000mL. This was previously entered.
56. Touched the Next button. The Disposable Kit Prime overlay displayed. Verified that the PlasmaLyte was attached and any welds and plastic clamps on the tubing leading to the PlasmaLyte were open, then touched the Yes button. NOTE: Because only one type of wash buffer (PlasmaLyte) was used during the LOVO procedure, no solution was attached to the tubing passing through Clamp 2. The Roberts clamp on this tubing remained closed during the procedure.
- 20 57. Disposable kit prime started and the Priming Disposable Kit Screen displayed. Visually observed that PlasmaLyte moving through the tubing connected to the bag of PlasmaL Lyte. If no fluid was moving, pressed the Pause Button on the screen and determined if a clamp or weld was still closed. Once the problem had been solved, pressed the Resume button on the screen to resume the Disposable Kit Prime.
- 25 58. When disposable kit prime finished successfully, the Connect Source Screen displayed.
59. For this protocol, the Source container was New and Off-Scale
60. If the Source container was already shown as New and Off-Scale , no changes were made.
- 30 61. If the Source location was shown as On-Scale, touched the On-Scale button to toggle to Off-Scale.
62. Touched the Source Capacity (mL) entry field. A numeric keypad displayed. Enter the capacity of the container that held the Source product. Touched the check button to accept the entry. Note: The Source Capacity entry was used to make sure that the Source bag was able to hold the additional solution that was added to the bag during the Source Prime phase.
- 35 63. Used sterile welding technique to attach the Source container to the tubing passing through Clamp S. Opened the weld. Remove the tubing from the clamp as needed.
- 40

64. Made sure to replace source tubing into the S clamp.
65. Touched the Next button. The Source Prime overlay displayed. Verified that the Source was attached to the disposable kit and any welds and plastic clamps on the tubing leading to the Source were open, then touched the Yes button.
- 5 66. Source prime started and the Priming Source Screen displayed. Visually observed that PlasmaLyte was moving through the tubing attached to the Source bag. If no fluid was moving, pressed the Pause Button on the screen and determined if a clamp or weld was still closed. Once the problem had been solved, pressed the Resume button on the screen to resume the Source Prime.
- 10 67. When Source prime finished successfully, the Start Procedure Screen displayed.
68. Pressed the Start button. The “Pre-Wash Cycle 1” pause screen appeared, with the instructions to “Coat IP, Mix Source”.
69. Pre-coated the IP bag.
- 15 70. Before pressing the Start button, removed the IP bag from weigh scale #2 (could also remove tubing from the IP top port tubing guide) and manually inverted it to allow the wash buffer added during the disposable kit prime step to coat all interior surfaces of the bag.
71. Re-hung the IP bag on weigh scale #2 (label on the bag faced to the left). Replaced the top port tubing in the tubing guide, if it was removed.
- 20 72. Mixed the Source bag.
73. Before pressing the Start button, removed the Source bag from weigh scale #1 and inverted it several times to create a homogeneous cell suspension.
74. Rehung the Source bag on weigh scale #1 or the IV pole. Made sure the bag was not swinging.
- 25 75. Pressed the Start button.
76. The LOVO started processing fluid from the Source bag and the Wash Cycle 1 Screen displayed.

30 **[00722]** During the LOVO procedure, the system automatically paused to allow the operator to interact with different bags. Different screens displayed during different pauses. Followed the corresponding instructions for each screen.

**[00723]** Source Rinse Pause

**[00724]** After draining the Source bag, the LOVO added wash buffer to the Source bag to rinse the bag. After the configured volume of wash buffer had been added to the Source bag, the LOVO paused automatically and displayed the Source Rinse Paused Screen.

35 **[00725]** When the Source Rinse Paused Screen displayed, the operator:

1. Removed the Source bag from weigh scale #1.
1. Inverted the Source bag several times to allow the wash buffer to touch the entire bag interior.

2. Re-hung the Source bag on weigh scale #1. Made sure the Source bag is not swinging on weigh scale #1.
3. Pressed the Resume button.

5 [00726] The LOVO processed the rinse fluid from the Source bag, then continued with the automated procedure.

[00727] Mix IP bag pause

[00728] To prepare cells for another pass through the spinner, the IP bag was diluted with wash buffer. After adding the wash buffer to the IP bag, the LOVO paused automatically and displayed the “Mix IP bag” Pause Screen.

10 [00729] When the “Mix IP bag” Pause Screen displayed, the operator:

1. Removed the IP bag from weigh scale #2. Could also remove the tubing from the IP top port tubing guide.
2. Inverted the IP bag several times to thoroughly mix the cell suspension.
- 15 3. Re-hung the IP bag on weigh scale #2. Also replaced the IP top port tubing in the tubing guide, if it was removed. Made sure the IP bag was not swinging on weigh scale #2.
4. Pressed the Resume button. The LOVO began processing fluid from the IP bag.

[00730] Massage IP corners pause

20 [00731] During the final wash cycle of the LOVO procedure, cells were pumped from the IP bag, through the spinner, and to the Retentate (Final Product) bag. When the IP bag was empty, 10 mL of wash buffers was added to the bottom port of the IP bag to rinse the bag. After adding the rinse fluid, the LOVO paused automatically and displayed the “Massage IP corners” Pause Screen.

[00732] When the “Massage IP corners” Pause Screen displayed, the operator:

- 25 1. Did NOT remove the IP bag from weigh scale #2.
2. With the IP bag still hanging on weigh scale #2, massaged the corners of the bag to bring any residual cells into suspension.
3. Made sure the IP bag was not swinging on weigh scale #2.
4. Pressed the Resume button.
- 30 5. The LOVO began pumping out the rinse fluid from the IP bag.

[00733] At the end of the LOVO procedure, the Remove Products Screen displayed. When this screen displayed, all bags on the LOVO kit could be manipulated.

**Note: Did not touch any bags until the Remove Products Screen displays.**

[00734] Placed a hemostat on the tubing very close to the port on the Retentate bag to keep the cell suspension from settling into the tubing and triple heat sealed below the hemostat.

[00735] Removed the retentate bag by breaking the middle seal and transferred to the BSC.

5 [00736] Followed the instructions on the Remove Products Screen

[00737] Touched the Next button. All LOVO mechanical clamps opened and the Remove Kit Screen displayed.

[00738] Followed the instructions on the Remove Kit screen. When completed proceeded.

[00739] Touched the Next button. All LOVO mechanical clamps closed and the Results Summary Screen displayed. Recorded the data from the results summary screen in Table 17. Closed all pumps and filtered support.

TABLE 17. LOVO results summary table.

Elapsed Processing Time (parentheses #)	Elapsed Source Processing Time (parentheses #)	Pause Time	Source Volume (mL)	Retentate Volume (mL)	Filtrate Volume (mL)	Solution 1 Volume (mL)
A.	B.	C.	D.	E.	F.	G.

[00740] Touched the Next button. The Protocol Selection Screen displayed.

15 [00741] LOVO Shutdown procedure

1. Ensured all clamps were closed and filter support is in the upright position.
2. Touched the STOP button on the front of the LOVO.
3. The STOP Button Decision Overlay displayed.
4. The Shutdown Confirmation Overlay displayed.
- 20 5. Touched the Yes button. The Shutting Down Screen displayed.
6. After a few seconds, the Power Off Screen displayed. When this screen displayed, turned off the LOVO using the switch on the back left of the instrument.

[00742] Recorded final formulated product volume in a table.

[00743] Calculate amount of IL-2 required from final product table

A. Calculated amount of IL-2 needed for final product. (300 IU/ml of IL-2 final product):

Final product volume (ml) [Volume of Formulated Cell Product from Final Formulated Product Volume Table] x 300IU/ml = IU of IL-2 required

\_\_\_\_\_ ml X \_\_\_\_\_ 300 IU \_\_\_\_\_ = \_\_\_\_\_ IU of IL-2 required

B. IU IL-2 required ÷ working stock dilution (Concentration of  $6 \times 10^4$  IU/mL) prepared in IL-2 preparation step = volume (ml) of IL-2 to add to final product.

\_\_\_\_\_ IU of IL-2 required from above] ÷ 60,000 IU/ml = \_\_\_\_\_ ml IL-2  
working stock

[00744] Determined the number of Cryobags and Retain Volume

5 [00745] Marked on the Target volume and retain table below the number of cryopreservation bags and volume of retention sample for product.

[00746] Targeted volume/bag calculation: (Final formulated volume – volume adjustment due to not getting 100% recovery=10 mL)/# bags.

[00747] Prepared cells with 1:1 (vol:vol) CS10 (CryoStor 10, BioLife Solutions) and IL-2.

- 10 1. Assemble Connect apparatus
  - 1.1. Sterile welded the CS750 cryobags to the CC2 Cell Connect apparatus replacing one of the distal male luer ends for each bag.
  - 1.2. Retained the clamps in the closed position.
  - 1.3. Labeled the bags 1-4.
- 15 2. Prepared cells with IL-2 and connected apparatus.
  - 2.1. In BSC spike the cell product bag with a 4" plasma transfer set with female luer connector. Be sure the clamp was closed on the transfer set.
  - 2.2. With an appropriate size syringe drew up the volume of IL-2 working dilution determined from the Final Product Table.
  - 20 2.3. Dispensed into LOVO product.
  - 2.4. Sterile welded LOVO product bag to CC2 single spike line removing the spike.
  - 2.5. Placed cells and apparatus in transport bag and place at 2-8 °C for ≤ 15 min.
3. Addition of CS10
  - 3.1. In BSC attached 3 way stopcock to male luer on bag of cold CS10.
  - 25 3.2. Attached appropriate size syringe to female luer of stopcock.

- 3.3. Unclamped bag and drew up the amount of CS10 determined in the “Final Formulated Product Volume” table.
- 3.4. Removed syringe and red capped.
- 3.5. Repeated if multiple syringes were required.
- 5 3.6. Removed cell/CC2 apparatus from 2-8 °C refrigerator and placed in BSC.
- 3.7. Attached first syringe containing CS10 to middle luer of stopcock. Turned stopcock so line to CS750 bags is in “OFF” position.
- 3.8. Slowly and with gentle mixing, added CS10 (1:1, vol:vol) to cells.
- 3.9. Repeated for additional syringes of CS10.

10 **[00748]** Addition of Formulated Cell Product into Cryobags

1. Replaced syringe with appropriate size syringe for volume of cells to be placed in each cryo bag.
2. Mixed cell product.
3. Opened the clamp leading to the cell product bag and drew up appropriate volume
- 15 4. Turned stopcock so cell product bag is in “OFF” position and dispensed the contents of the syringe into cryobag #1. Cleared the line with air from syringe.

**[00749]** Record final product volume

1. Using needless port and appropriate size syringe, drew up amount of retain determined previously.
- 20 2. Place retained in 50 mL conical tube labelled “Retain”
3. Using the syringe attached to the harness removed all air from bag drawing up cells to about 1” past bag into tubing. Clamped and heat sealed. Placed at 2-8 °C.
4. Turned stopcock so cryo bags were in the “OFF” position
5. Mixed cells in cell product bag and repeat steps 3-8 for remaining CS750 bags using a
- 25 6. Retained should be set aside for processing once product was in CRF.

**[00750]** Controlled-rate freezer (CRF) procedure (see also Example 9)

1. Turned on the CRF (CryoMed Controlled Rate Freezer, Model 7454) and associated laptop computer.
- 30 2. Logged onto the computer using account and password
3. Opened Controlled Rate Freezer icon located on the desktop.
4. Clicked the Run button on the Main screen.
5. Clicked Open Profile, Click Open.
6. Entered the Run File Name followed by the date in this format: runMMDDYYYY.
- 35 7. Entered the Data Tag as the date with no dashes as MMDDYYYY.
8. Closed door to the CRF.
9. Clicked Start Run.
10. Selected COM 6 on the pull down menu.
11. Clicked Ok. Waited about 30 seconds.

12. When "Profile Download," pops up, Clicked OK. Clicked Save. (See Example 9 for controlled-rate freezing profile details.)
13. Waited to press green button until the samples were in the CRF. The freezer was held at 4 °C until ready to add them.
- 5 14. Added samples to CRF.
15. Waited until CRF returns to 4 °C. Once temperature was reached, clicked the green continue button. This initiated program to go to next step in program.
16. Performed a visual inspection of the cryobags for the following (Note: did not inspect for over or underfill): container integrity, port integrity, seal integrity, presence of cell clumps, and presence of particles.
- 10 17. Placed approved hang tag labels on each bag.
18. Verified final product label including: Lot number, product name, manufacturer date, product volume, other additives, storage temperature, and expiration.
19. Placed each cryobag (with hangtag) into an over-bag.
- 15 20. Heat sealed.
21. Placed in a cold cassette.
22. Repeated for each bag.
23. Placed the labeled cryobags into preconditioned cassettes and transferred to the CRF.
24. Evenly distributed the cassettes in the rack in the CRF.
- 20 25. Applied ribbon thermocouple to the center cassette, or place dummy bag in center position.
26. Closed the door to the CRF.
27. Once the chamber temperature reached 4 °C +/- 1.5 °C, Press Run on the PC Interface software.
- 25 28. Recorded the time and the chamber temperature that the product is transferred to the CRF.
- [00751] Processing of quality control sample
1. Aseptically transferred the following materials to the BSC, as needed, and labeled according to the table below:
- 30 2. Used a new pipette for pipette the following:  
QC and Retention Table
3. Delivered to QC: 1 -Cell Count tube, 1- Endotoxin tube, 1-Mycoplasma tube, 1-Gram stain tube, 1 tube restimulation tube, and 1- flow tube to QC for immediate testing. The remaining duplicate tubes were placed in the controlled rate freezer.
- 35 4. Contacted the QC supervisor notifying of required testing.
5. See Table 18 for testing and storage instructions.

TABLE 18. Testing and storage instructions.

Test	Vessel
Cell Count and viability	Cryovials.

Mycoplasma	Cryovial stored at 4 °C until testing completed.
Sterility	Inoculate 0.5 mL into an anaerobic and 0.5mL into an aerobic culture bottle.
Gram Stain	Cryovial stored at 4 °C until testing completed.
Endotoxin	Cryovial stored at 4 °C until testing completed.
Flow	Cryovial stored at 4 °C until testing completed.
Post Formulation Retention	Cryopreserve for future testing: Consist of 5 satellite vial, 1 -Cell Count tube, 1- Endotoxin tube, 1-Mycoplasma tube, 1-Gram stain tube, and 1- flow tube to QC for immediate testing.
Restimulation	Sample is delivered at room temperature and assay must be started within 30 minutes of cell count results.

**[00752] Cell Count**

**[00753]** Performed a single cell count on each sample and recorded data and attached counting raw data to batch record. Document the Cellometer counting program. Verified the correct dilution was entered into the Cellometer.

**[00754] Cryopreservation of Post Formulation Retention Cells:**

1. Placed vial in CRF.
2. Moved to storage location after completion of freeze and recorded date and time placed in CFR. Recorded date and time moved to LN<sub>2</sub>.

10 **[00755] Microbiology testing**

1. Ordered testing for settle plates to the microbiology lab.
2. Recorded accession numbers.
3. Ordered testing for aerobic and anaerobic sterility.
4. Ensured delivery of plates and bottles to the microbiology lab.

15 **[00756] Post-Cryopreservation of Cell Product Bags**

1. Stopped the freezer after the completion of the run. Run could be stopped by clicking on the Stop button or pressing the Back key on the freezer keypad.
2. Removed cryobags from cassette
3. Transferred cassettes to vapor phase LN<sub>2</sub>.
- 20 4. Recorded storage location.

5. Entered any additional comments when the text entry window opens again. This window appeared regardless of the Run stop method.
6. Printed the profile report and attached to the batch record labeled with the lot number for the run.
- 5 7. Terminated Warm Mode and closed the Run screen with Exit button.

#### **EXAMPLE 9: CRYOPRESERVATION PROCESS**

[00757] This example describes the cryopreservation process method for TILs prepared with the abbreviated, closed procedure described above in Example 8 using the CryoMed Controlled Rate Freezer, Model 7454 (Thermo Scientific).

- 10 [00758] The equipment used, in addition to that described in Example 9, is as follows: aluminum cassette holder rack (compatible with CS750 freezer bags), cryostorage cassettes for 750 mL bags, low pressure (22 psi) liquid nitrogen tank, refrigerator, thermocouple sensor (ribbon type for bags), and CryoStore CS750 Freezing bags (OriGen Scientific).

- 15 [00759] The freezing process provides for a 0.5 °C rate from nucleation to -20 °C and 1 °C per minute cooling rate to -80 °C end temperature. The program parameters are as follows: Step 1 - wait at 4 °C; Step 2: 1.0 °C/min (sample temperature) to -4 °C; Step 3: 20.0 °C/min (chamber temperature) to -45 °C; Step 4: 10.0 °C/min (chamber temperature) to -10.0 °C; Step 5: 0.5 °C/min (chamber temperature) to -20 °C; and Step 6: 1.0 °C/min (sample temperature) to -80 °C.

- 20 [00760] A depiction of the procedure of this example in conjunction with the process of Examples 1 to 8 is shown in Figure 11.

#### **EXAMPLE 10: CHARACTERIZATION OF PROCESS 2A TILS**

- This example describes the characterization of TILs prepared with the abbreviated, closed procedure described above. In summary, the abbreviated, closed procedure (process 2A, described in Examples 1 to 9) had the advantages over prior TIL manufacturing processes given in Table 19. Advantages for the Pre-REP can include: increased tumor fragments per flask, shortened culture time, reduced number of steps, and/or being amenable to closed system. Advantages for the Pre-REP to REP transition can include: shortened pre-REP-to-REP process, reduced number of steps, eliminated phenotyping selection, and/or amenable to closed system. Advantages for the REP can include: reduced number of steps, shorter REP duration, closed system transfer of TIL between flasks, and/or closed system media exchanges. Advantages for the Harvest can include: reduced number of steps, automated cell
- 25
- 30

washing, closed system, and reduced loss of product during wash. Advantages for the final formulation and/or product can include shipping flexibility.

TABLE 19. Comparison of exemplary process 1C and an embodiment of process 2A.

Process Step	Process 1C - Embodiment	Process 2A - Embodiment
<b>Pre-REP</b>	<ul style="list-style-type: none"> <li>• 4 fragments per 10 G-REX -10 flasks</li> <li>• 11-21 day duration</li> </ul>	<ul style="list-style-type: none"> <li>• 40 fragments per 1 G-REX -100M flask</li> <li>• 11 day duration</li> </ul>
<b>Pre-REP to REP Transition</b>	<ul style="list-style-type: none"> <li>• Pre-REP TIL are frozen until phenotyped for selection then thawed to proceed to the REP (~day 30)</li> <li>• REP requires <math>&gt;40 \times 10^6</math> TIL</li> </ul>	<ul style="list-style-type: none"> <li>• Pre-REP TIL directly move to REP on day 11</li> <li>• REP requires <math>25-200 \times 10^6</math> TIL</li> </ul>
<b>REP</b>	<ul style="list-style-type: none"> <li>• 6 G-REX -100M flasks on REP day 0</li> <li>• <math>5 \times 10^6</math> TIL and <math>5 \times 10^8</math> PBMC feeders per flask on REP day 0</li> <li>• Split to 18-36 flasks on REP day 7</li> <li>• 14 day duration</li> </ul>	<ul style="list-style-type: none"> <li>• 1 G-REX -500M flask on day 11</li> <li>• <math>25-200 \times 10^6</math> TIL and <math>5 \times 10^9</math> PBMC feeders on day 11</li> <li>• Split to <math>\leq 6</math> G-REX -500M flasks on day 16</li> <li>• 11 day duration</li> </ul>
<b>Harvest</b>	<ul style="list-style-type: none"> <li>• TIL harvested via centrifugation</li> </ul>	<ul style="list-style-type: none"> <li>• TIL harvested via LOVO automated cell washing system'</li> </ul>
<b>Final Formulation</b>	<ul style="list-style-type: none"> <li>• Fresh product in Hypothermosol</li> <li>• Single infusion bag</li> <li>• Limited shipping stability</li> </ul>	<ul style="list-style-type: none"> <li>• Cryopreserved product in PlasmaLyte-A + 1% HSA and CS10 stored in LN<sub>2</sub></li> <li>• Multiple aliquots</li> <li>• Longer shipping stability</li> </ul>
<b>Overall Estimated Process Time</b>	<ul style="list-style-type: none"> <li>• 43-55 days</li> </ul>	<ul style="list-style-type: none"> <li>• 22 days</li> </ul>

[00761] A total of 9 experiments were performed using TILs derived from 9 tumors described in Table 20. All the data shown here was measured from thawed frozen TIL product from process 1C and an embodiment of process 2A.

TABLE 20. Description of Tumor Donors, Processing Dates and Processing Locations.

Tumor ID	Tissue type	Source	Tissue
M1061	Melanoma	MT group	Primary – left lateral foot
M1062	Melanoma	Moffitt	N/A
M1063	Melanoma	MT group	Metastatic C - right groin
M1064	Melanoma	MT group	Metastatic C - left ankle
M1065	Melanoma	Bio Options	Metastatic-Axillary lymph node
EP11001	ER+PR+	MT group	Primary - left breast invasive ductal carcinoma
M1056*	Melanoma	Moffitt	N/A
M1058*	Melanoma	MT group	Metastatic - Stage IIB Right scalp
M1023*	Melanoma	Atlantic Health	Primary - Right axilla

[00762] The procedures described herein for process 2A were used to produce the TILs for characterization in this example. Briefly, for the REP, on Day 11, one G-REX -500M flask containing 5 L of CM2 supplemented with 3000 IU/ml rhil-2, 30ng/mL anti-CD3 (Clone

5 OKT3) and  $5 \times 10^9$  irradiated allogeneic feeder PBMC cells was prepared. TILs harvested from the pre-REP G-REX -100M flask after volume reduction were counted and seeded into the G-REX -500M flask at a density that ranged between  $5 \times 10^6$  and  $200 \times 10^6$  cells. The flask was then placed in a humidified 37 °C, 5% CO<sub>2</sub> tissue culture incubator for five days. On Day 16, volume of the G-REX -500M flask was reduced, TILs were counted and their

10 viability determined. At this point, the TIL were expanded into multiple G-REX -500M flasks (up to a maximum of six flasks), each with a seeding density of  $1 \times 10^9$  TILs/flask. All flasks were then placed in humidified 37 °C, 5% CO<sub>2</sub> tissue culture incubators for an

additional six days. On Day 22, the day of harvest, each flask was volume reduced by 90%, the cells were pooled together and filtered through a 170  $\mu\text{m}$  blood filter, and then collected into a 3 L Origin EV3000 bag or equivalent in preparation for automated washing using the LOVO. TILs were washed using the LOVO automated cell processing system which  
5 replaced 99.99% of cell culture media with a wash buffer consisting of PlasmaLyte-A supplemented with 1% HSA. The LOVO operates using spinning filtration membrane technology that recovers over 92% of the TIL while virtually eliminating residual tissue culture components, including serum, growth factors, and cytokines, as well as other debris and particulates. After completion of the wash, a cell count was performed to determine the  
10 expansion of the TILs and their viability upon harvest. CS10 was added to the washed TIL at a 1:1 volume:volume ratio to achieve the Process 2A final formulation. The final formulated product was aliquoted into cryostorage bags, sealed, and placed in pre-cooled aluminum cassettes. Cryostorage bags containing TIL were then frozen using a CryoMed Controlled Rate Freezer (ThermoFisher Scientific, Waltham, MA) according to the procedures described  
15 herein, including in Example 9.

**[00763]** Cell counts and percentage viability for the nine runs were compared in Figures 12 and 13.

**[00764]** The cell surface markers shown in the following results were analyzed using flow cytometry (Canto II flow cytometer, Becton, Dickinson, and Co., Franklin Lakes, NJ, USA)  
20 using suitable commercially-available reagents. Results for markers of interest are shown in Figure 14 through Figure 23.

**[00765]** Diverse methods have been used to measure the length of telomeres in genomic DNA and cytological preparations. The telomere restriction fragment (TRF) analysis is the gold standard to measure telomere length (de Lange et al., 1990). However, the major  
25 limitation of TRF is the requirement of a large amount of DNA (1.5  $\mu\text{g}$ ). Here, two widely used techniques for the measurement of telomere lengths were applied, namely fluorescence in situ hybridization (FISH) and quantitative PCR.

**[00766]** Flow-FISH was performed using the Dako kit (K532711-8 RUO Code K5327 Telomere PNA Kit/FITC for Flow Cytometry, PNA FISH Kit/FITC. Flow, 20 tests) and the  
30 manufacturer's instructions were followed to measure average length of telomere repeat. Briefly, the cells were surface was stained with CD3 APC for 20 minutes at 4°C, followed by GAM Alexa 546 for 20 minutes. The antigen-antibody complex was then cross-linked with 2

mM BS3 (Fisher Scientific) chemical cross-linker. PNA-telomere probe binding in a standard population of T-cells with long telomeres, Jurkat 1301 T leukemia cell line (1301 cells) was used as an internal reference standard in each assay. Individual TILs were counted following antibody incubation and mixed with 1301 cells (ATCC) at a 1:1 cell ratio.  $5 \times 10^5$  TILs were mixed with  $5 \times 10^5$  1301 cells. *In situ* hybridization was performed in hybridization solution (70% formamide, 1% BSA, 20mM Tris pH 7.0) in duplicate and in the presence and absence of a FITC-conjugated Telomere PNA probe (Panagene), FITC-00-CCC-TAA-CCC-TAA-CCC-TAA, complementary to the telomere repeat sequence at a final concentration of 60nM. After addition of the Telomere PNA probe, cells were incubated for 10 minutes at 81°C in a shaking water bath. The cells were then placed in the dark at room temperature overnight. The next morning, excess telomere probe was removed by washing 2 times with PBS pre-warmed to 40°C. Following the washes, DAPI (Invitrogen, Carlsbad, CA) was added at a final concentration of 75 ng/mL. DNA staining with DAPI was used to gate cells in the G0/G1 population. Sample analysis was performed using our flow cytometer (BD Canto II, Mountain View, CA). Telomere fluorescence of the test sample was expressed as a percentage of the fluorescence (fl) of the 1301 cells per the following formula: Relative telomere length = [(mean FITC fl test cells w/ probe - mean FITC fl test cells w/o probe) × DNA index 1301 cells × 100] / [(mean FITC fl 1301 cells w/probe - mean FITC fl 1301 cells w/o probe) × DNA index test cell].

[00767] Real time qPCR was also used to measure relative telomere length (Nucleic Acids Res. 2002 May 15; 30(10): e47., 20, Leukemia, 2013, 27, 897–906). Briefly, the telomere repeat copy number to single gene copy number (T/S) ratio was determined using an BioRad PCR thermal cycler (Hercules, CA) in a 96-well format. Ten ng of genomic DNA was used for either the telomere or hemoglobin (hgb) PCR reaction and the primers used were as follows: Tel-1b primer (CGG TTT GTT TGG GTT TGG GTT TGG GTT TGG GTT TGG GTT), Tel-2b primer (GGC TTG CCT TAC CCT TAC CCT TAC CCT TAC CCT TAC CCT), hgb1 primer (GCTTCTGACACAACACTGTGTTCACTAGC), and hgb2 primer (CACCAACTTCATCCACGTTTACC). All samples were analyzed by both the telomere and hemoglobin reactions, and the analysis was performed in triplicate on the same plate. In addition to the test samples, each 96-well plate contained a five-point standard curve from 0.08 ng to 250 ng using genomic DNA isolated from 1301 cell line. The T/S ratio (-dCt) for each sample was calculated by subtracting the median hemoglobin threshold cycle (Ct) value

from the median telomere Ct value. The relative T/S ratio (-ddCt) was determined by subtracting the T/S ratio of the 10.0 ng standard curve point from the T/S ratio of each unknown sample.

5 [00768] Flow-FISH results are shown in Figures 24 and 25, and no significant differences were observed between process 1C and process 2A, suggesting that the surprising properties of the TILs produced by process 2A were not predictable from the age of the TILs alone.

[00769] In conclusion, process 2A produced a potent TIL product with a “young” phenotype as defined by high levels of co-stimulatory molecules, low levels of exhaustion markers, and an increased capability to secrete cytokine upon reactivation. The abbreviated 22 day  
10 expansion platform allows for the rapid generation of clinical scale doses of TILs for patients in urgent need of therapy. The cryopreserved drug product introduces critical logistical efficiencies allowing rapid manufacture and flexibility in distribution. This expansion method overcomes traditional barriers to the wider application of TIL therapy.

#### 15 **EXAMPLE 11: USE OF IL-2, IL-15, AND IL-21 CYTOKINE COCKTAIL**

[00770] This example describes the use of IL-2, IL-15, and IL-21 cytokines, which serve as additional T cell growth factors, in combination with the TIL process of Examples 1 to 10.

[00771] Using the process of Examples 1 to 10, TILs were grown from colorectal, melanoma, cervical, triple negative breast, lung and renal tumors in presence of IL-2 in one  
20 arm of the experiment and, in place of IL-2, a combination of IL-2, IL-15, and IL-21 in another arm at the initiation of culture. At the completion of the pre-REP, cultures were assessed for expansion, phenotype, function (CD107a+ and IFN- $\gamma$ ) and TCR V $\beta$  repertoire. IL-15 and IL-21 are described elsewhere herein and in Gruijl, et al., IL-21 promotes the expansion of CD27+CD28+ tumor infiltrating lymphocytes with high cytotoxic potential and  
25 low collateral expansion of regulatory T cells, *Santegoets, S. J., J Transl Med., 2013, 11:37* (<https://www.ncbi.nlm.nih.gov/pmc/articles/PMC3626797/>).

[00772] The results showed that enhanced TIL expansion (>20%), in both CD4<sup>+</sup> and CD8<sup>+</sup> cells in the IL-2, IL-15, and IL-21 treated conditions were observed in multiple histologies relative to the IL-2 only conditions. There was a skewing towards a predominantly CD8<sup>+</sup>  
30 population with a skewed TCR V $\beta$  repertoire in the TILs obtained from the IL-2, IL-15, and

IL-21 treated cultures relative to the IL-2 only cultures. IFN- $\gamma$  and CD107a were elevated in the IL-2, IL-15, and IL-21 treated TILs, in comparison to TILs treated only IL-2.

#### **EXAMPLE 12: PHASE 2, MULTICENTER, THREE-COHORT STUDY IN 5 MELANOMA**

[00773] This Phase 2, multicenter, three-cohort study is designed to assess the safety and efficacy of a TIL therapy manufactured according to process 1C (as described herein) in patient with metastatic melanoma. Cohorts one and two will enroll up to 30 patients each and cohort three is a re-treatment cohort for a second TIL infusion in up to ten patients. The first  
10 two cohorts are evaluating two different manufacturing processes: processes 1C and an embodiment of process 2A (described in Examples 1 to 10, respectively. Patients in cohort one receive fresh, non-cryopreserved TIL and cohort two patients receive product manufactured through the process described in Examples 1 to 10, yielding a cryopreserved product. The study design is shown in FIG. 26. The study is a Phase 2, multicenter, three  
15 cohort study to assess the safety and efficacy of autologous TILs for treatment of subpopulations of patients with metastatic melanoma. Key inclusion criteria include: measurable metastatic melanoma and  $\geq 1$  lesion resectable for TIL generation; at least one prior line of systemic therapy; age  $\geq 18$ ; and ECOG performance status of 0-1. Treatment cohorts include non-cryopreserved TIL product (prepared using process 1C), cryopreserved  
20 TIL product (prepared using an embodiment of process 2A), and retreatment with TIL product for patients without response or who progress after initial response. The primary endpoint is safety and the secondary endpoint is efficacy, defined as objective response rate (ORR), complete remission rate (CRR), progression free survival (PFS), duration of response (DOR), and overall survival (OS).

25

#### **EXAMPLE 13: QUALIFYING INDIVIDUAL LOTS OF GAMMA-IRRADIATED PERIPHERAL MONONUCLEAR CELLS**

[00774] This Example describes a novel abbreviated procedure for qualifying individual lots of gamma-irradiated peripheral mononuclear cells (PBMCs, also known as MNC) for use as  
30 allogeneic feeder cells in the exemplary methods described herein.

[00775] Each irradiated MNC feeder lot was prepared from an individual donor. Each lot or donor was screened individually for its ability to expand TIL in the REP in the presence of purified anti-CD3 (clone OKT3) antibody and interleukin-2 (IL-2). In addition, each lot of feeder cells was tested without the addition of TIL to verify that the received dose of gamma radiation was sufficient to render them replication incompetent.

### Definitions/Abbreviations

- BSC – Biological Safety Cabinet  
 CD3 – Cluster of Differentiation 3; surface marker protein T-lymphocytes  
 CF – Centrifugal  
 10 CM2 – Complete Medium for TIL #  
 CMO – Contract Manufacturing Organization  
 CO<sub>2</sub> – Carbon Dioxide  
 EtOH – Ethyl Alcohol  
 GMP – Good Manufacturing Practice  
 15 IL-2 – Interleukin 2  
 IU – International Units  
 LN2 – Liquid Nitrogen  
 mini-REP – Mini-Rapid Expansion Protocol  
 ml – Milliliter  
 20 MNC – Mononuclear Cells  
 NA – Not Applicable  
 OKT3 – MACS GMP CD3 pure (clone OKT3) antibody  
 PPE – Personal Protective Equipment  
 Pre-REP – Before Rapid Expansion Protocol  
 25 QS – Quantum Satis; fill to this quantity  
 REP – Rapid Expansion Protocol  
 TIL – Tumor Infiltrating Lymphocytes  
 T25 – 25cm<sup>2</sup> tissue culture flask  
 µg – Micrograms  
 30 µL – Microliter

### PROCEDURE

#### Background

- 7.1.1 Gamma-irradiated, growth-arrested MNC feeder cells were required for REP of TIL. Membrane receptors on the feeder MNCs bind to anti-CD3 (clone OKT3) antibody and crosslink to TIL in the REP flask, stimulating the TIL to expand. Feeder lots were prepared from the leukapheresis of whole blood taken from individual donors. The leukapheresis product was subjected to centrifugation over Ficoll-Hypaque, washed, irradiated, and cryopreserved under GMP conditions.
- 7.1.2 It is important that patients who received TIL therapy not be infused with viable feeder cells as this can result in Graft-Versus-Host Disease (GVHD). Feeder cells are therefore growth-arrested by dosing the cells with gamma-

irradiation, resulting in double strand DNA breaks and the loss of cell viability of the MNC cells upon reculture.

#### Evaluation Criteria and Experimental Set-Up

**[00776]** Feeder lots were evaluated on two criteria: 1) their ability to expand TIL in co-culture >100-fold and 2) their replication incompetency.

7.2.2 Feeder lots were tested in mini-REP format utilizing two primary pre-REP TIL lines grown in upright T25 tissue culture flasks.

7.2.3 Feeder lots were tested against two distinct TIL lines, as each TIL line is unique in its ability to proliferate in response to activation in a REP.

10 7.2.4 As a control, a lot of irradiated MNC feeder cells which has historically been shown to meet the criteria of 7.2.1 was run alongside the test lots.

7.2.5 To ensure that all lots tested in a single experiment receive equivalent testing, sufficient stocks of the same pre-REP TIL lines were available to test all conditions and all feeder lots.

15 7.2.6 For each lot of feeder cells tested, there was a total of six T25 flasks:

7.2.6.1 Pre-REP TIL line #1 (2 flasks)

7.2.6.2 Pre-REP TIL line #2 (2 flasks)

7.2.6.3 Feeder control (2 flasks)

20 NOTE: Flasks containing TIL lines #1 and #2 evaluated the ability of the feeder lot to expand TIL. The feeder control flasks evaluated the replication incompetence of the feeder lot.

#### **[00777]** Experimental Protocol

7.3.1 Day -2/3, Thaw of TIL lines

7.3.1.1 Prepared CM2 medium.

25 7.3.1.2 Warmed CM2 in 37°C water bath.

7.3.1.3 Prepared 40 ml of CM2 supplemented with 3000IU/ml IL-2. Keep warm until use.

7.3.1.4 Placed 20 ml of pre-warmed CM2 without IL-2 into each of two 50ml conical tubes labeled with names of the TIL lines used.

30 7.3.1.5 Removed the two designated pre-REP TIL lines from LN2 storage and transferred the vials to the tissue culture room.

7.3.1.6 Recorded TIL line identification.

7.3.1.7 Thawed vials by placing them inside a sealed zipper storage bag in a 37°C water bath until a small amount of ice remains.

35 7.3.1.8 Sprayed or wiped thawed vials with 70% ethanol and transfer vials to BSC.

- 7.3.1.9 Using a sterile transfer pipet, immediately transferred the contents of vial into the 20ml of CM2 in the prepared, labeled 50ml conical tube.
- 7.3.1.10 QS to 40ml using CM2 without IL-2 to wash cells.
- 5 7.3.1.11 Centrifuged at 400 x CF for 5 minutes.
- 7.3.1.12 Aspirated the supernatant and resuspend in 5ml warm CM2 supplemented with 3000 IU/ml IL-2.
- 7.3.1.13 Removed small aliquot (20 $\mu$ l) in duplicate for cell counting using an automated cell counter. Record the counts.
- 10 7.3.1.14 While counting, placed the 50ml conical tube with TIL cells into a humidified 37°C, 5% CO<sub>2</sub> incubator, with the cap loosened to allow for gas exchange.
- 7.3.1.15 Determined cell concentration and dilute TIL to 1 x 10<sup>6</sup> cells/ml in CM2 supplemented with IL-2 at 3000 IU/ml.
- 15 7.3.1.16 Cultured in 2ml/well of a 24-well tissue culture plate in as many wells as needed in a humidified 37°C incubator until Day 0 of the mini-REP.
- 7.3.1.17 Cultured the different TIL lines in separate 24-well tissue culture plates to avoid confusion and potential cross-contamination.
- 20
- 7.3.2 Day 0, initiate Mini-REP
- 7.3.2.1 Prepared enough CM2 medium for the number of feeder lots to be tested. (e.g., for testing 4 feeder lots at one time, prepared 800ml of CM2 medium).
- 25 7.3.2.2 Aliquoted a portion of the CM2 prepared in 7.3.2.1 and supplement it with 3000 IU/ml IL-2 for the culturing of the cells. (e.g., for testing 4 feeder lots at one time, prepare 500ml of CM2 medium with 3000 IU/ml IL-2).
- 7.3.2.3 The remainder of the CM2 with no IL-2 will be used for washing of cells as described below.
- 30 7.3.2.4 Working with each TIL line separately to prevent cross-contamination, removed the 24-well plate with TIL culture from the incubator and transferred to the BSC.
- 7.3.2.5 Using a sterile transfer pipet or 100-1000 $\mu$ l Pipettor and tip, removed about 1ml of medium from each well of TIL to be used and place in an unused well of the 24-well tissue culture plate. This was used for washing wells.
- 35 7.3.2.6 Using a fresh sterile transfer pipet or 100-1000 $\mu$ l Pipettor and tip, mixed remaining medium with TIL in wells to resuspend the cells and then transferred the cell suspension to a 50ml conical tube labeled with the TIL name and recorded the volume.
- 40

- 7.3.2.7 Washed the wells with the reserved media and transferred that volume to the same 50ml conical tube.
- 7.3.2.8 Spun the cells at 400 x CF to collect the cell pellet.
- 5 7.3.2.9 Aspirated off the media supernatant and resuspend the cell pellet in 2-5ml of CM2 medium containing 3000 IU/ml IL-2, volume to be used based on the number of wells harvested and the size of the pellet – volume should be sufficient to ensure a concentration of  $>1.3 \times 10^6$  cells/ml.
- 10 7.3.2.10 Using a serological pipet, mixed the cell suspension thoroughly and recorded the volume.
- 7.3.2.11 Removed 200 $\mu$ l for a cell count using an automated cell counter.
- 7.3.2.12 While counting, placed the 50ml conical tube with TIL cells into a humidified, 5% CO<sub>2</sub>, 37°C incubator, with the cap loosened to allow gas exchange.
- 15 7.3.2.13 Recorded the counts.
- 7.3.2.14 Removed the 50ml conical tube containing the TIL cells from the incubator and resuspend them cells at a concentration of  $1.3 \times 10^6$  cells/ml in warm CM2 supplemented with 3000IU/ml IL-2. Returned the 50ml conical tube to the incubator with a loosened cap.
- 20 7.3.2.15 If desired, kept the original 24-well plate to reculture any residual TIL.
- 7.3.2.16 Repeated steps 7.3.2.4 - 7.3.2.15 for the second TIL line.
- 25 7.3.2.17 Just prior to plating the TIL into the T25 flasks for the experiment, TIL were diluted 1:10 for a final concentration of  $1.3 \times 10^5$  cells/ml as per step 7.3.2.35 below.
- [00778] Prepare MACS GMP CD3 pure (OKT3) working solution
- 7.3.2.18 Took out stock solution of OKT3 (1mg/ml) from 4°C refrigerator and placed in BSC.
- 30 7.3.2.19 A final concentration of 30ng/ml OKT3 was used in the media of the mini-REP.
- 7.3.2.20 600ng of OKT3 were needed for 20ml in each T25 flask of the experiment; this was the equivalent of 60 $\mu$ l of a 10 $\mu$ g/ml solution for each 20ml, or 360 $\mu$ l for all 6 flasks tested for each feeder lot.
- 35 7.3.2.21 For each feeder lot tested, made 400 $\mu$ l of a 1:100 dilution of 1mg/ml OKT3 for a working concentration of 10 $\mu$ g/ml (e.g., for testing 4 feeder lots at one time, make 1600 $\mu$ l of a 1:100 dilution of 1mg/ml OKT3: 16 $\mu$ l of 1mg/ml OKT3 + 1.584ml of CM2 medium with 3000IU/ml IL-2.)
- 40 [00779] Prepare T25 flasks

7.3.2.22 Labeled each flask with the name of the TIL line tested, flask replicate number, feeder lot number, date, and initials of analyst.

7.3.2.23 Filled flask with the CM2 medium prior to preparing the feeder cells.

5 7.3.2.24 Placed flasks into 37°C humidified 5% CO<sub>2</sub> incubator to keep media warm while waiting to add the remaining components.

7.3.2.25 Once feeder cells were prepared, the components will be added to the CM2 in each flask.

[00780] Prepare MACS GMP CD3 pure (OKT3) working solution.

10 TABLE 21: Solutions

Component	Volume in co-culture flasks	Volume in control (feeder only) flasks
CM2 + 3000 IU/ml IL-2	18ml	19ml
MNC: $1.3 \times 10^7$ /ml in CM2 + 3000IU IL-2 (final concentration $1.3 \times 10^7$ /flask)	1ml	1ml
OKT3: 10µg/ml in CM2 + 3000IU IL-2	60µl	60µl
TIL: $1.3 \times 10^5$ /ml in CM2 with 3000IU of IL-2 (final concentration $1.3 \times 10^5$ /flask)	1ml	0

[00781] Prepare Feeder Cells

15 7.3.2.26 A minimum of  $78 \times 10^6$  feeder cells were needed per lot tested for this protocol. Each 1ml vial frozen by SDBB had  $100 \times 10^6$  viable cells upon freezing. Assuming a 50% recovery upon thaw from LN2 storage, it was recommended to thaw at least two 1ml vials of feeder cells per lot giving an estimated  $100 \times 10^6$  viable cells for each REP. Alternately, if supplied in 1.8ml vials, only one vial provided enough feeder cells.

20 7.3.2.27 Before thawing feeder cells, pre-warmed approximately 50ml of CM2 without IL-2 for each feeder lot to be tested.

7.3.2.28 Removed the designated feeder lot vials from LN2 storage, placed in zipper storage bag, and place on ice. Transferred vials to tissue culture room.

25 7.3.2.29 Thawed vials inside closed zipper storage bag by immersing in a 37°C water bath.

7.3.2.30 Removed vials from zipper bag, spray or wipe with 70% EtOH and transferred vials to BSC.

30 7.3.2.31 Using a transfer pipet immediately transferred the contents of feeder vials into 30ml of warm CM2 in a 50ml conical tube. Washed vial with a small volume of CM2 to remove any residual cells in the vial.

7.3.2.32 Centrifuged at 400 x CF for 5 minutes.

- 7.3.2.33 Aspirated the supernatant and resuspended in 4ml warm CM2 plus 3000 IU/ml IL-2.
- 7.3.2.34 Removed 200  $\mu$ l for cell counting using the Automated Cell Counter. Recorded the counts.
- 5 7.3.2.34 Resuspended cells at  $1.3 \times 10^7$  cells/ml in warm CM2 plus 3000 IU/ml IL-2.
- 7.3.2.34 Diluted TIL cells from  $1.3 \times 10^6$  cells/ml to  $1.3 \times 10^5$  cells/ml. Worked with each TIL line independently to prevent cross-contamination.
- 10 [00782] Setup Co-Culture
- 7.3.2.36 Diluted TIL cells from  $1.3 \times 10^6$  cells/ml to  $1.3 \times 10^5$  cells/ml. Worked with each TIL line independently to prevent cross-contamination.
- 15 7.3.2.36.1 Added 4.5ml of CM2 medium to a 15ml conical tube.
- 7.3.2.36.2 Removed TIL cells from incubator and resuspended well using a 10ml serological pipet.
- 7.3.2.36.3 Removed 0.5ml of cells from the  $1.3 \times 10^6$  cells/ml TIL suspension and added to the 4.5ml of medium in the 15ml conical tube. Returned TIL stock vial to incubator.
- 20 7.3.2.36.4 Mixed well.
- 7.3.2.36.5 Repeated steps 7.3.2.36.1 – 7.3.2.36.4 for the second TIL line.
- 25 7.3.2.36.6 If testing more than one feeder lot at one time, diluted the TIL to the lower concentration for each feeder lot just prior to plating the TIL.
- 7.3.2.37 Transferred flasks with pre-warmed media for a single feeder lot from the incubator to the BSC.
- 7.3.2.38 Mixed feeder cells by pipetting up and down several times with a 1ml pipet tip and transferred 1 ml ( $1.3 \times 10^7$  cells) to each flask for that feeder lot.
- 30 7.3.2.39 Added 60 $\mu$ l of OKT3 working stock (10 $\mu$ g/ml) to each flask.
- 7.3.2.40 Returned the two control flasks to the incubator.
- 7.3.2.41 Transferred 1 ml ( $1.3 \times 10^5$ ) of each TIL lot to the correspondingly labeled T25 flask.
- 35 7.3.2.42 Returned flasks to the incubator and incubate upright. Did not disturb until Day 5.
- 7.3.2.43 Repeated 7.3.2.36 – 7.3.2.42 for all feeder lots tested.
- [00783] Day 5, Media change

- 7.3.3.1 Prepared CM2 with 3000 IU/ml IL-2. 10ml is needed for each flask
- 7.3.3.2 To prevent cross-contamination, handled the flasks for a single feeder lot at a time. Removed flasks from the incubator and transfer to the BSC, care was taken not to disturb the cell layer on the bottom of the flask.
- 5 7.3.3.3 Repeated for all flasks including control flask.
- 7.3.3.4 With a 10ml pipette, transferred 10ml warm CM2 with 3000 IU/ml IL-2 to each flask.
- 7.3.3.5 Returned flasks to the incubator and incubate upright until Day 7. Repeated 7.3.3.1 - 7.3.3.6 for all feeder lots tested.
- 10 **[00784]** Day 7, Harvest
- 7.3.4.1 To prevent cross-contamination, handled the flasks for a single feeder lot at a time.
- 7.3.4.2 Removed flasks from the incubator and transfer to the BSC, care as taken not to disturb the cell layer on the bottom of the flask.
- 15 7.3.4.3 Without disturbing the cells growing on the bottom of the flasks, removed 10ml of medium from each test flask and 15ml of medium from each of the control flasks.
- 7.3.4.4 Using a 10ml serological pipet, resuspended the cells in the remaining medium and mix well to break up any clumps of cells.
- 20 7.3.4.5 Recorded the volumes for each flask.
- 7.3.4.6 After thoroughly mixing cell suspension by pipetting, removed 200µl for cell counting.
- 7.3.4.7 Counted the TIL using the appropriate standard operating procedure in conjunction with the automatic cell counter equipment.
- 25 7.3.4.8 Recorded counts in Day 7.
- 7.3.4.9 Repeated 7.3.4.1 – 7.3.4.8 for all feeder lots tested.
- 7.3.4.10 Feeder control flasks were evaluated for replication incompetence and flasks containing TIL were evaluated for fold expansion from Day 0 according to the criteria listed in Table 21 (below).
- 30 **[00785]** Day 7, Continuation of Feeder Control Flasks to Day 14
- 7.3.5.1 After completing the Day 7 counts of the feeder control flasks, added 15ml of fresh CM2 medium containing 3000 IU/ml IL-2 to each of the control flasks.
- 7.3.5.2 Returned the control flasks to the incubator and incubated in an upright position until Day 14.
- 35 **[00786]** Day 14, Extended Non-proliferation of Feeder Control Flasks
- 7.3.6.1 To prevent cross-contamination, handled the flasks for a single feeder lot at a time.

- 7.3.6.2 Removed flasks from the incubator and transfer to the BSC, care was taken not to disturb the cell layer on the bottom of the flask.
- 7.3.6.3 Without disturbing the cells growing on the bottom of the flasks, removed approximately 17ml of medium from each control flasks.
- 5 7.3.6.4 Using a 5ml serological pipet, resuspended the cells in the remaining medium and mixed well to break up any clumps of cells.
- 7.3.6.5 Recorded the volumes for each flask.
- 7.3.6.6 After thoroughly mixing cell suspension by pipetting, removed 200µl for cell counting.
- 10 7.3.6.7 Counted the TIL using the appropriate standard operating procedure in conjunction with the automatic cell counter equipment.
- 7.3.6.8 Recorded counts.
- 7.3.6.9 Repeated 7.3.4.1 – 7.3.4.8 for all feeder lots tested.

## RESULTS AND ACCEPTANCE CRITERIA

- 15 [00787] Results
- 10.1.1 The dose of gamma irradiation was sufficient to render the feeder cells replication incompetent. All lots were expected to meet the evaluation criteria and also demonstrated a reduction in the total viable number of feeder cells remaining on Day 7 of the REP culture compared to Day 0.
- 20 10.1.2 All feeder lots were expected to meet the evaluation criteria of 100-fold expansion of TIL growth by Day 7 of the REP culture.
- 10.1.3 Day 14 counts of Feeder Control flasks were expected to continue the non-proliferative trend seen on Day 7.
- [00788] Acceptance Criteria
- 25 10.2.1 The following acceptance criteria were met for each replicate TIL line tested for each lot of feeder cells
- 10.2.2 Acceptance was two-fold, as follows (outlined in the Table below).

TABLE 22: Acceptance Criteria

Test	Acceptance criteria
Irradiation of MNC / Replication Incompetence	No growth observed at 7 and 14 days
TIL expansion	At least a 100-fold expansion of each TIL (minimum of $1.3 \times 10^7$ viable cells)

- 30 10.2.2.1 Evaluated whether the dose of radiation was sufficient to render the MNC feeder cells replication incompetent when cultured in the presence of 30ng/ml OKT3 antibody and 3000 IU/ml IL-2.

- 10.2.2.1.1 Replication incompetence was evaluated by total viable cell count (TVC) as determined by automated cell counting on Day 7 and Day 14 of the REP.
- 5 10.2.2.1.2 Acceptance criteria was “No Growth,” meaning the total viable cell number has not increased on Day 7 and Day 14 from the initial viable cell number put into culture on Day 0 of the REP.
- 10.2.2.2 Evaluated the ability of the feeder cells to support TIL expansion.
- 10 10.2.2.2.1 TIL growth was measured in terms of fold expansion of viable cells from the onset of culture on Day 0 of the REP to Day 7 of the REP.
- 15 10.2.2.2.1 On Day 7, TIL cultures achieved a minimum of 100-fold expansion, (i.e., greater than 100 times the number of total viable TIL cells put into culture on REP Day 0), as evaluated by automated cell counting.
- 10.2.2.3 Should a lot fail to meet the two criteria above, the lot was retested according to the contingency plan outlined in Section 10.3 below.
- 20 10.2.2.4 Following retesting of a failed lot, any MNC feeder lot that did not meet the two acceptance criteria in both the original evaluation and the contingency testing was excluded.
- 10.2.2.5 Any MNC feeder lots that meet acceptance criteria but were judged to have poor performance in regard to the ability to expand TIL relative to other previous feeder lots tested in parallel with the same pre-REP TIL lines were excluded.
- 25 **[00789]** Contingency Testing of MNC Feeder Lots that do not meet acceptance criteria
- 10.3.1 In the event that an MNC feeder lot did not meet the either of the acceptance criteria outlined in Section 10.2 above, the following steps will be taken to retest the lot to rule out simple experimenter error as its cause.
- 30 10.3.2 If there are two or more remaining satellite testing vials of the lot, then the lot was retested. If there were one or no remaining satellite testing vials of the lot, then the lot was failed according to the acceptance criteria listed in Section 10.2 above.
- 10.3.3 Two trained personnel, include the original person who evaluated the lot in question, both tested the lot at the same time.
- 35 10.3.4 Repeating Section 7.2 – 7.3 was done to re-evaluate the lot in question.
- 10.3.5 Each person tested the lot in question as well as a control lot (as defined in Section 7.2.4 above).
- 10.3.6 In order to be qualified, the lot in question and the control lot had to achieve the acceptance criteria of Section 10.2 for both of the personnel doing the contingency testing.
- 40 10.3.7 Upon meeting these criteria, the lot was then released for CMO use as outlined in Section 10.2 above.

**EXAMPLE 14: QUALIFYING INDIVIDUAL LOTS OF GAMMA-IRRADIATED PERIPHERAL BLOOD MONONUCLEAR CELLS**

[00790] This Example describes a novel abbreviated procedure for qualifying individual lots of gamma-irradiated peripheral blood mononuclear cells (PBMC) for use as allogeneic feeder cells in the exemplary methods described herein. This example provides a protocol for the evaluation of irradiated PBMC cell lots for use in the production of clinical lots of TIL. Each irradiated PBMC lot was prepared from an individual donor. Over the course of more than 100 qualification protocols, it was been shown that, in all cases, irradiated PBMC lots from SDBB (San Diego Blood Bank) expand TIL >100-fold on Day 7 of a REP. This modified qualification protocol was intended to apply to irradiated donor PBMC lots from SDBB which were then further tested to verify that the received dose of gamma radiation was sufficient to render them replication incompetent. Once demonstrated that they maintained replication incompetence over the course of 14 days, donor PBMC lots were considered “qualified” for usage to produce clinical lots of TIL.

**[00791] Key Terms and Definitions**

µg – Microgram

µl – Microliter

AIM-V – commercially available cell culture medium Biological Safety Cabinet

20 BSC – Cluster of Differentiation

CD – Complete Medium for TIL #2

CM2 – CM2 supplemented with 3000 IU/ml IL-2

CM2IL2 – Contract Manufacturing Organization

CO<sub>2</sub> – Carbon Dioxide

25 EtOH – Ethanol

GMP – Good Manufacturing Practices

Gy – Gray

IL – Interleukin

IU – International Units

30 LN2 – Liquid Nitrogen

MI – Milliliter

NA – Not Applicable

OKT3 – anti-CD3 monoclonal antibody designation

P20 – 2-20 $\mu$ l pipettor

P200 – 20-200 $\mu$ l pipettor

PBMC – peripheral blood mononuclear cells

5 P1000 – 100-1000 $\mu$ l pipettor

PPE – Personal Protective Equipment

REP – Rapid Expansion Protocol

SDBB – San Diego Blood Bank

TIL – Tumor Infiltrating Lymphocytes

10 T25 – 25cm<sup>2</sup> tissue culture flask

x g – “times gravity” – measure of relative centrifugal force

**[00792]** Specimens include Irradiated donor PBMC (SDBB).

Procedure

Background

15 7.1.1 Gamma-irradiated, growth-arrested PBMC were required for current standard  
 20 REP of TIL. Membrane receptors on the PBMCs bind to anti-CD3 (clone  
 OKT3) antibody and crosslink to TIL in culture, stimulating the TIL to  
 expand. PBMC lots were prepared from the leukapheresis of whole blood  
 taken from individual donors. The leukapheresis product was subjected to  
 centrifugation over Ficoll-Hypaque, washed, irradiated, and cryopreserved  
 under GMP conditions.

25 It is important that patients who received TIL therapy not be infused with  
 viable PBMCs as this could result in Graft-Versus-Host Disease (GVHD).  
 Donor PBMCs are therefore growth-arrested by dosing the cells with gamma-  
 irradiation, resulting in double strand DNA breaks and the loss of cell viability  
 of the PBMCs upon reculture.

Evaluation Criteria

7.2.1 Evaluation criterion for irradiated PBMC lots was their replication  
 incompetency.

30 Experimental Set-up

7.3.1 Feeder lots were tested in mini-REP format as if they were to be co-cultured  
 with TIL, using upright T25 tissue culture flasks.

35 7.3.1.1 Control lot: One lot of irradiated PBMCs, which had historically  
 been shown to meet the criterion of 7.2.1, was run alongside the  
 experimental lots as a control.

7.3.2 For each lot of irradiated donor PBMC tested, duplicate flasks was run.

Experimental Protocol

[00793] All tissue culture work in this protocol was done using sterile technique in a BSC.

Day 0

- 5 7.4.1 Prepared ~90ml of CM2 medium for each lot of donor PBMC to be tested. Kept CM2 warm in 37°C water bath.
- 7.4.2 Thawed an aliquot of  $6 \times 10^6$  IU/ml IL-2.
- 10 7.4.3 Returned the CM2 medium to the BSC, wiping with 70% EtOH prior to placing in hood. For each lot of PBMC tested, removed about 60ml of CM2 to a separate sterile bottle. Added IL-2 from the thawed  $6 \times 10^6$  IU/ml stock solution to this medium for a final concentration of 3000 IU/ml. Labeled this bottle as "CM2/IL2" (or similar) to distinguish it from the unsupplemented CM2.
- 7.4.4 Labeled two T25 flasks for each lot of PBMC to be tested. Minimal label included:
- 15 7.4.4.1 Lot number
- 7.4.4.2 Flask number (1 or 2)
- 7.4.4.3 Date of initiation of culture (Day 0)

Prepare OKT3

- 20 7.4.5 Took out the stock solution of anti-CD3 (OKT3) from the 4°C refrigerator and placed in the BSC.
- 7.4.6 A final concentration of 30ng/ml OKT3 was used in the media of the mini-REP.
- 7.4.7 Prepared a 10µg/ml working solution of anti-CD3 (OKT3) from the 1mg/ml stock solution. Placed in refrigerator until needed.
- 25 7.4.7.1 For each PBMC lot tested, prepare 150µl of a 1:100 dilution of the anti-CD3 (OKT3) stock
- E.g., for testing 4 PBMC lots at one time, prepare 600µl of 10µg/ml anti-CD3 (OKT3) by adding 6µl of the 1mg/ml stock solution to 594µl of CM2 supplemented with 3000 IU/ml IL-2.

30 Prepare Flasks

- 7.4.8 Added 19ml per flask of CM2/IL-2 to the labeled T25 flasks and placed flasks into 37°C, humidified, 5% CO<sub>2</sub> incubator while preparing cells.

Prepare Irradiate PBMC

- 35 7.4.9 Worked with each donor PBMC lot individually to avoid the potential cross-contamination of the lots.
- 7.4.10 Retrieved vials of PBMC lots to be tested from LN2 storage. These were placed at -80°C or kept on dry ice prior to thawing.

- 5 7.4.11 Placed 30ml of CM2 (without IL-2 supplement) into 50ml conical tubes for each lot to be thawed. Labeled each tube with the different lot numbers of the PBMC to be thawed. Capped tubes tightly and place in 37°C water bath prior to use. As needed, returned 50ml conical tubes to the BSC, wiping with 70% EtOH prior to placing in the hood.
- 7.4.12 Removed a vial PBMC from cold storage and place in a floating tube rack in a 37°C water bath to thaw. Allowed thaw to proceed until a small amount of ice remains in the vial.
- 7.4.13 Sprayed or wiped thawed vial with 70% EtOH and transfer to BSC.
- 10 7.4.14 Using a sterile transfer pipet, immediately transferred the contents of the vial into the 30ml of CM2 in the 50ml conical tube. Removed about 1ml of medium from the tube to rinse the vial; returned rinse to the 50ml conical tube. Capped tightly and swirl gently to wash cells.
- 7.4.15 Centrifuged at 400 x g for 5min at room temperature.
- 15 7.4.16 Aspirated the supernatant and resuspend the cell pellet in 1ml of warm CM2/IL-2 using a 1000µl pipet tip. Alternately, prior to adding medium, resuspended cell pellet by dragging capped tube along an empty tube rack. After resuspending the cell pellet, brought volume to 4ml using CM2/IL-2 medium. Recorded volume.
- 20 7.4.17 Removed a small aliquot (e.g., 100µl) for cell counting using an automated cell counter.
- 25 7.4.17.1 Performed counts in duplicate according to the particular automated cell counter SOP. It most likely was necessary to perform a dilution of the PBMC prior to performing the cell counts. A recommended starting dilution was 1:10, but this varied depending on the type of cell counter used.
- 7.4.17.2 Recorded the counts.
- 30 7.4.18 Adjusted concentration of PBMC to  $1.3 \times 10^7$  cells/ml as per the worksheet in step 7.4.15.2 using CM2/IL-2 medium. Mixed well by gentle swirling or by gently aspirating up-and-down using a serological pipet.

#### Set Up Culture Flasks

- 7.4.19 Returned two labeled T25 flasks to the BSC from the tissue culture incubator.
- 7.4.20 Returned the 10µg/ml vial of anti-CD3/OKT3 to the BSC.
- 7.4.21 Added 1ml of the  $1.3 \times 10^7$  PBMC cell suspension to each flask.
- 35 7.4.22 Added 60µl of the 10µg/ml anti-CD3/OKT3 to each flask.
- 7.4.23 Returned capped flasks to the tissue culture incubators for 14 days of growth without disturbance.
- 7.4.24 Placed anti-CD3/OKT3 vial back into the refrigerator until needed for the next lot.
- 40 7.4.25 Repeated steps 7.4.9 – 7.4.24 for each lot of PBMC to be evaluated.

#### Day 14, Measurement of Non-proliferation of PBMC

- 7.4.26 Working with each lot independently, carefully returned the duplicate T25 flasks to the BSC.
- 5 7.4.27 For each flask, using a fresh 10ml serological pipet, removed ~17ml from each of the flasks, then carefully pulled up the remaining media to measure the volume remaining in the flasks. Recorded volume.
- 7.4.28 Mixed sample well by pipetting up and down using the same serological pipet.
- 7.4.29 Removed a 200µl sample from each flask for counting.
- 7.4.30 Counted cells using an automated cell counter.
- 7.4.31 Repeated steps 7.4.26 – 7.4.31 for each lot of PBMC being evaluated.

## 10 RESULTS AND ACCEPTANCE CRITERION

### Results

- 15 10.1.1 The dose of gamma irradiation was expected to be sufficient to render the feeder cells replication incompetent. All lots were expected to meet the evaluation criterion, demonstrating a reduction in the total viable number of feeder cells remaining on Day 14 of the REP culture compared to Day 0.

### Acceptance Criterion

- 20 10.2.1 The following acceptance criterion were met for each irradiated donor PBMC lot tested:
- 10.2.2 “No growth” – meant that the total number of viable cells on Day 14 was less than the initial viable cell number put into culture on Day 0 of the REP.
- 10.2.3 Should a lot fail to meet the criterion above, the lot was retested per the Contingency Testing Procedure outlined in the section 10.4.
- 25 10.2.4 Following retesting of a failed lot, any MNC feeder lot that did not meet the acceptance criterion in both the original evaluation and the contingency testing was excluded.

### Contingency Testing of PBMC lots which do not meet acceptance criterion.

- 30 10.4.1 In the event than an irradiated donor PBMC lot did not meet the acceptance criterion above, the following steps were taken to retest the lot to rule out simple experimenter error as the cause of its failure.
- 10.4.2 If there were two or more remaining satellite vials of the lot, then the lot was retested. If there are one or no remaining satellite vials of the lot, then the lot was failed according to the acceptance criterion of section 10.2 above.
- 35 10.4.3 Whenever possible, two trained personnel (preferably including the original person who evaluated the lot in question) did the testing of the two separate vials independently. This was the preferred method of contingency testing. Aside from the separate vials of PBMC, the same reagents could be used by both personnel.

- 10.4.3.1. If two personnel were not available, one person did the testing of the two PBMC vials for the failed lot, working with each vial independently.
- 5 10.4.4 Repeating of section 7.4 “Experimental Protocol” was done to re-evaluated the lot in question.
- 10.4.5 In addition to the lot in question, a control lot was tested by each person carrying out the contingency testing.
- 10.4.5.1 If two personnel perform contingency testing, both personnel tested the control lot independently.
- 10 10.4.5.2 If only one person is available to perform contingency testing, it was not necessary for the control lot to be run in duplicate.
- 10.4.5.3 To be qualified, a PBMC lot going through contingency testing had both the control lot and both replicates of the lot in question achieve the acceptance criterion of Section 10.2 to pass.
- 15 10.4.5.4 Upon meeting this criterion, the lot was then released for CMO usage as outlined in section 10.2.

#### **EXAMPLE 15: CELLOMETER IC2 IMAGE CYTOMETER AUTOMATIC CELL COUNTER**

20 **[00794]** This Example describes the procedure for operation of the Cellometer K2 Image Cytometer automatic cell counter.

##### **1. Definitions**

- μl Microliter
- AOPI Acridine Orange Propidium Iodine
- 25 BSC Biological Safety Cabinet
- DPBS Dulbecco's Phosphate Buffered Saline
- ml Milliliter
- MNC Mononuclear Blood Cells
- NA Not Applicable
- 30 PBMC Peripheral Blood Mononuclear Cells
- PPE Personal Protective Equipment
- Pre-REP Initial TIL culture before Rapid Expansion Protocol of culture
- REP Rapid Expansion Protocol
- TIL Tumor Infiltrating Lymphocytes

35

##### **7. Procedure**

## 7.1 Cell suspension preparation

### 7.1.1 Trypan Blue Preparation

The final Trypan blue concentration was 0.1%. The manufacturer recommended preparing a stock solution of 0.2%.

- 5                   7.1.1.1   When using Trypan blue on the Cellometer K2, diluted the stock (0.4 %) with PBS to 0.2 %.
- 7.1.1.2   Filtered the Trypan blue with a 0.2-0.4 micron filter and aliquot in small volumes into labeled, capped tubes.
- 7.1.1.3   Mixed the cell suspension at 1:1 with 0.2 % trypan blue.

### 10                 7.1.2 AOPI Preparation

- 7.1.2.1   When using AOPI on the Cellometer K2, obtained the AOPI solution.
- 7.1.2.2   Stained cell sample at 1:1 with AOPI solution.

15                 NOTE: When counting high concentration cultures, diluted the cell samples in cell culture medium prior to the final 1:1 dilution with Trypan Blue or AOPI.

Used manufacturer's suggested range of counting to determine the best dilution to use.

## 7.2 Cellometer K2 Set-Up

- 20                 7.2.1   Turned on the Cellometer K2 equipment.
- 7.2.2   Selected the Cellometer Image Cytometer icon on the associated computer monitor.
- 7.2.3   On the main screen of the software, selected one of the Assays listed in the dropdown box.
- 25                   7.2.3.1   When selecting the appropriate Assay, the Cell Type and Image Mode self-populated.
- 7.2.3.2   Under "Sample" section, clicked on Set User/Sample ID to open another screen to input operator's information for specimen.
- 30                   7.2.3.2.1   Entered "User ID". This will consist of the user's three letter initials.
- 7.2.3.2.2   Entered "Sample ID". The sample ID is derived from incoming specimen information.
- 7.2.3.3   Set up dilution parameters.
- 35                   7.2.3.3.1   If no other dilution was made besides the 1:1 mixture, the dilution factor was 2.
- 7.2.3.3.2   If a dilution was made prior to the final 1:1 mixture, the dilution factor was 2 times of the prior dilution.

- 5
- 7.2.3.3.3 Updated dilution factor according to the mixture used in the dilution section of the screen. Clicked on the pencil icon to bring up the dialog screens.
- 7.2.3.3.4 Verified that F1 Image and F2 Image sections are identical to each other.
- 7.2.3.3.5 Clicked on the "Save" button after set up has been completed.
- 10        7.3    Cell Counting
- 7.3.1 Removed the plastic backing from both sides of a Cellometer counting chamber slide (SD100) and placed it on top of a clean, lint-free wipe.
- 7.3.2 After preparing the cell suspension, removed a small aliquot of the sample and transferred it into a well of a multiwell cell culture plate or
- 15        tube.
- 7.3.3 If diluting the sample, performed the dilution using cell culture medium.
- 7.3.4 Added 20  $\mu$ l of cell suspension into a well of the multiwell cell culture plate or tube.
- 20        7.3.5 Added 20  $\mu$ l of 0.2% trypan blue or the AOPI solution to the 20  $\mu$ l of cell suspension and mix sample thoroughly.
- 7.3.6 Measured 20  $\mu$ l of the 1:1 solution and transferred it into one side of the counting chamber.
- NOTE: Avoided touching the clear area of the slide.
- 25        7.3.7 If necessary, repeated the sample on the other side of the slide. 7.3.8. Inserted the chamber into the slot on the front of the Cellometer.
- 7.3.8 For the AOPI cell counting, clicked on "Preview F1" on the main screen to preview the green fluorescent image (live cell) image. For Trypan blue counting, clicked on "Preview Brightfield".
- 30        7.3.9 Using the focusing wheel, brought image into optimal focus. Cells had a bright center and a clearly-defined edge.
- 7.3.10 Clicked "Count" to begin the counting process.
- 7.3.11 Results were displayed in a counting results pop-up box on the computer screen showing the results of the counting process.
- 35

#### **EXAMPLE 16: PREPARATION OF IL-2 STOCK SOLUTION (CELLGENIX)**

**[00795]** This Example describes the process of dissolving purified, lyophilized recombinant human interleukin-2 into stock samples suitable for use in further tissue culture protocols,

including all of those described in the present application and Examples, including those that involve using rhIL-2.

### 3. Definitions/Abbreviations

μL: microliter

5 BSC: Biological Safety Cabinet

BSL2: Biosafety Level 2

D-PBS: Dulbecco's Phosphate Buffered Saline

G: Gauge

GMP: Good Manufacturing Processing

10 HAc: Acetic Acid

HSA: Human Serum Albumin

mL: Milliliter

NA: Not applicable

PPE: Personal Protective Equipment

15 rhIL-2; IL-2: Recombinant human Interleukin-2

COA: Certificate of Analysis

### 6. Procedure

#### 6.1 Prepare 0.2% Acetic Acid solution (HAc).

6.1.1 Transferred 29mL sterile water to a 50mL conical tube.

20 6.1.2 Added 1mL 1N acetic acid to the 50mL conical tube.

6.1.3 Mixed well by inverting tube 2-3 times.

6.1.4 Sterilized the HAc solution by filtration using a Steriflip filter.

6.1.5 Capped, dated, and labeled the solution "Sterile 0.2% Acetic Acid Solution."

25 6.1.6 Solution expired after 2 months. Stored at room temperature.

#### 6.2 Prepare 1% HSA in PBS.

6.2.1 Added 4mL of 25% HSA stock solution to 96mL PBS in a 150mL sterile filter unit.

6.2.2 Filtered solution.

30 6.2.3 Capped, dated, and labeled the solution "1% HSA in PBS."

6.2.4 Solution expired after 2 months. Store 4°C.

#### 6.3 For each vial of rhIL-2 prepared, fill out forms.

#### 6.4 Prepared rhIL-2 stock solution (6 x 10<sup>6</sup> IU/mL final concentration)

35 6.4.1 Each lot of rhIL-2 was different and required information found in the manufacturer's Certificate of Analysis (COA), such as:

6.4.1.1 Mass of rhIL-2 per vial (mg)

6.4.1.2 Specific activity of rhIL-2 (IU/mg)

6.4.1.3 Recommended 0.2% HAc reconstitution volume (mL)

5

6.4.2 Calculated the volume of 1% HSA required for rhIL-2 lot by using the equation below:

$$\left( \frac{\text{Vial Mass (mg)} \times \text{Biological Activity} \left( \frac{\text{IU}}{\text{mg}} \right)}{6 \times 10^6 \frac{\text{IU}}{\text{mL}}} \right) - \text{HAc vol (mL)} = 1\% \text{ HSA vol (mL)}$$

10

6.4.2.1 For example, according to CellGenix's rhIL-2 lot 10200121 COA, the specific activity for the 1mg vial is  $25 \times 10^6$  IU/mg. It recommends reconstituting the rhIL-2 in 2mL 0.2% HAc.

$$\left( \frac{1 \text{ mg} \times 25 \times 10^6 \frac{\text{IU}}{\text{mg}}}{6 \times 10^6 \frac{\text{IU}}{\text{mL}}} \right) - 2 \text{ mL} = 2.167 \text{ mL HSA}$$

15

6.4.3 Wiped rubber stopper of IL-2 vial with alcohol wipe.

6.4.4 Using a 16G needle attached to a 3mL syringe, injected recommended volume of 0.2% HAc into vial. Took care to not dislodge the stopper as the needle is withdrawn.

6.4.5 Inverted vial 3 times and swirled until all powder is dissolved.

6.4.6 Carefully removed the stopper and set aside on an alcohol wipe.

20

6.4.7 Added the calculated volume of 1% HSA to the vial.

6.4.8 Capped the vial with the rubber stopper.

6.5 Storage of rhIL-2 solution

6.5.1 For short-term storage (<72hrs), stored vial at 4°C.

25

6.5.2 For long-term storage (>72hrs), aliquoted vial into smaller volumes and stored in cryovials at -20°C until ready to use. Avoided freeze/thaw cycles. Expired 6 months after date of preparation.

6.5.3 Rh-IL-2 labels included vendor and catalog number, lot number, expiration date, operator initials, concentration and volume of aliquot.

**EXAMPLE 17: PREPARATION OF MEDIA FOR PRE-REP AND REP PROCESSES**

[00796] This Example describes the procedure for the preparation of tissue culture media for use in protocols involving the culture of tumor infiltrating lymphocytes (TIL) derived from various tumor types including, but not limited to, metastatic melanoma, head and neck squamous cell carcinoma (HNSCC), ovarian carcinoma, triple-negative breast carcinoma, and lung adenocarcinoma. This media can be used for preparation of any of the TILs described in the present application and Examples.

**3. Definition**

- μg microgram
- 10 μm micrometer
- μM micromolar
- AIM-V® serum-free tissue culture medium (Thermo Fisher Scientific)
- BSC Biological Safety Cabinet
- CM1 Complete Medium #1
- 15 CM2 Complete Medium #2
- CM3 Complete Medium #3
- CM4 Complete Medium #4
- IU or U International units
- ml milliliter
- 20 mM millimolar
- NA not applicable
- PPE personal protective equipment
- Pre-REP pre-Rapid Expansion Process
- REP Rapid Expansion Process
- 25 rhIL-2, IL-2 recombinant human Interleukin-2
- RPMI1640 Roswell Park Memorial Institute medium, formulation 1640
- SOP Standard Operating Procedure
- TIL tumor infiltrating lymphocytes
- 7. **Procedure**
- 30 7.1 All procedures are done using sterile technique in a BSC (Class II, Type A2).
  - 7.1.1 Sprayed surface of hood with 70% ethanol prior to its use.
  - 7.1.2 Sprayed all items and reagents with 70% ethanol prior to placing them into tissue culture hood.
- 7.2 Aliquotting of 200mM L-glutamine

- 5
- 7.2.1 L-glutamine was supplied in larger volumes than needed for the preparation of serum (e.g., 100ml or 500ml volumes).
- 7.2.2 Thawed bottle of L-glutamine in 37°C water bath.
- 7.2.3 Mixed L-glutamine well after thawing, as it precipitates after thaw. Ensured that all precipitates have returned to solution prior to aliquotting.
- 7.2.4 Placed 5-10ml aliquots of L-glutamine into sterile 15ml conical tubes.
- 7.2.5 Labeled tubes with concentration, vendor, lot number, date aliquotted, and expiration date.
- 10 7.2.6 Tubes were then stored at -20°C and pulled as needed for media preparation.
- 7.3 Preparation of CM1
- 7.3.1 Removed the following reagents from cold storage and warmed them in a 37°C water bath:
- 15 7.3.1.1 RPMI1640
- 7.3.1.2 Human AB serum
- 7.3.1.3 200mM L-glutamine
- 7.3.2 Removed the BME from 4°C storage and place in tissue culture hood.
- 7.3.3 Placed the gentamycin stock solution from room temperature storage into tissue culture hood.
- 20 7.3.4 Prepared CM1 medium according to Table 23 below by adding each of the ingredients into the top section of a 0.2um filter unit appropriate to the volume to be filtered.

**TABLE 23. Preparation of CM1**

Ingredient	Final concentration	Final Volume 500 ml	Final Volume IL
RPMI1640	NA	450 ml	900 ml
Human AB serum, heat-inactivated 10%	50 ml	100 ml	
200mM L-glutamine	2 mM	5 ml	10 ml
55mM BME	55 µM	0.5 ml	1 ml
50mg/ml gentamicin sulfate	50 µg/ml	0.5 ml	1 ml

25

- 7.3.5 Labeled the CM1 media bottle with its name, the initials of the preparer, the date it was filtered/prepared, the two week expiration date and store at 4°C until needed for tissue culture. Media can be aliquotted into smaller volume bottles as required.

- 7.3.6 Any remaining RPMI1640, Human AB serum, or L-glutamine was stored at 4°C until next preparation of media.
- 7.3.7 Stock bottle of BME was returned to 4°C storage.
- 5 7.3.8 Stock bottle of gentamicin was returned to its proper RT storage location.
- 7.3.9 Because of the limited buffering capacity of the medium, CM1 was discarded no more than two weeks after preparation, or as the phenol red pH indicator showed an extreme shift in pH (bright red to pink coloration).
- 10 7.3.10 On the day of use, prewarmed required amount of CM1 in 37°C water bath and add 6000 IU/ml IL-2.
- 7.3.11 Additional supplementation - as needed
- 7.3.11.1 CM1 supplemented with GlutaMAX®
- 15 7.3.11.1.1 CM1 could be prepared by substituting 2mM GlutaMAX™ for 2mM glutamine (final concentration, see Table 2.) If this was done, labeled the media bottle as in Step 7.3.5 above adding "2mM GlutaMAX" to prevent confusion with the standard formulation of CM1.
- 20 7.3.11.2 CM1 supplemented with extra antibiotic/antimycotic
- 7.3.11.2.1 Some CM1 formulations required additional antibiotic or antimycotic to prevent contamination of pre-REP TIL grown from certain tumor types.
- 25 7.3.11.2.2 Added antibiotic/antimycotic to the final concentrations shown in Table 24 below.
- 7.3.11.2.3 If this was done, label the media bottle as in Step 7.3.1 above adding the name/s of the additional antibiotic/antimycotic to prevent confusion with the standard formulation of CM1.
- 30

**TABLE 24. Additional supplementation of CM1, as needed.**

Supplement	Stock concentration	Dilution	Final concentration
GlutaMAX™	200mM	1:100	2mM
Penicillin/streptomycin	10,000 U/ml penicillin 10,000µg/ml streptomycin	1:100	100 U/ml penicillin 100 µg/ml streptomycin
Amphotericin B	250µg/ml	1:100	2.5µg/ml

- 7.4 Preparation of CM2
- 7.4.1 Removed prepared CM1 from refrigerator or prepare fresh CM1 as per Section 7.3 above.
- 7.4.2 Removed AIM-V® from refrigerator.
- 5 7.4.3 Prepared the amount of CM2 needed by mixing prepared CM1 with an equal volume of AIM-V® in a sterile media bottle.
- 7.4.4 Added 3000 IU/ml IL-2 to CM2 medium on the day of usage.
- 7.4.5 Made sufficient amount of CM2 with 3000 IU/ml IL-2 on the day of usage.
- 10 7.4.6 Labeled the CM2 media bottle with its name, the initials of the preparer, the date it was filtered/prepared, the two week expiration date and store at 4°C until needed for tissue culture. Media was aliquotted into smaller volume bottles as required.
- 7.4.7 Returned any CM2 without IL-2 to the refrigerator where it can be stored for up to two weeks, or until phenol red pH indicator shows an extreme shift in pH (bright red to pink coloration).
- 15
- 7.5 Preparation of CM3
- 7.5.1 Prepared CM3 on the day it was required for use.
- 7.5.2 CM3 was the same as AIM-V® medium, supplemented with 3000 IU/ml IL-2 on the day of use.
- 20
- 7.5.3 Prepared an amount of CM3 sufficient to experimental needs by adding IL-2 stock solution directly to the bottle or bag of AIM-V. Mixed well by gentle shaking. Label bottle with "3000 IU/ml IL-2" immediately after adding to the AIM-V. If there was excess CM3, stored it in bottles at 4°C labeled with the media name, the initials of the preparer, the date the media was prepared, and its expiration date (7 days after preparation).
- 25
- 7.5.4 Discarded media supplemented with IL-2 after 7 days storage at 4°C.
- 7.6 Preparation of CM4
- 30 7.6.1 CM4 was the same as CM3, with the additional supplement of 2mM G1utaMAX™ (final concentration).
- 7.6.1.1 For every 1L of CM3, added 10ml of 200mM G1utaMAX™.
- 7.6.2 Prepared an amount of CM4 sufficient to experimental needs by adding IL-2 stock solution and G1utaMAX™ stock solution directly to the bottle or bag of AIM-V. Mixed well by gentle shaking.
- 35
- 7.6.3 Labeled bottle with "3000 IL/ml IL-2 and G1utaMAX" immediately after adding to the AIM-V.
- 7.6.4 If there was excess CM4, stored it in bottles at 4°C labeled with the media name, "G1utaMAX", the initials of the preparer, the date the media was prepared, and its expiration date (7 days after preparation).
- 40

7.6.5 Discarded media supplemented with IL-2 after 7 days storage at 4°C.

### EXAMPLE 18: SURFACE ANTIGEN STAINING OF POST REP TIL

#### 1. PURPOSE

5 [00797] The Example describes the procedure for cell surface staining of post-REP TILs by flow cytometry. This procedure can be applied to any TILs described in the application and Examples.

#### [00798] KEY TERMS AND DEFINITIONS

10         $\alpha$ :     Alpha  
          $\beta$ :     Beta  
          $\mu$ l:    Microliter  
         APC: Allophycocyanin  
         Ax647: Alex Fluor 647  
         BD:     Becton Dickinson Company  
15        BSA: Bovine Serum Albumin  
         BSC: Biological Safety Cabinet  
         BV421: Brilliant Violet 421  
         CD:    Cluster of Differentiation  
         CST: Cytometer Setup and Tracking  
20        Cy:     Cyanine  
         DPBS: Dulbecco's Phosphate Buffered Saline  
         FACS: Fluorescence Activated Cell Sorter  
         FBS: Fetal Bovine Serum  
         FITC: Fluorescein Isothiocyanate  
25        FMO: Fluorescence Minus One  
         G:     Gram  
         H7:    Analog of Cy7  
         Ml:    Milliliter  
         PE:    Phycoerythrin  
30        PerCP-Cy5.5: Peridinin-Chlorophyll proteins  
         PPE: Personal Protective Equipment  
         REP: Rapid Expansion Protocol  
         SIT: Sample Injection Tube

TCR: T Cell Receptor

w/v: Weight to Volume

### Flow Cytometry Antibodies and Stains

**TABLE 25:** Live/Dead Aqua Stain ThermoFisher Catalog # L34966.

Target	Format	Clone	Supplier	Catalog Number
TCRab ( <i>i.e.</i> , TCR $\alpha/\beta$ )	PE/Cy7	IP26	BioLegend	306720
CD57	PerCP-Cy5.5	HNK-1	BioLegend	359622
CD28	PE	CD28.2	BioLegend	302908
CD4	FITC	OKT4	eBioscience	11-0048-42
CD27	APC-H7	M-T271	BD Biosciences	560222
CD56	APC	N901	Beckman Coulter	IM2474U
CD8a	PB	RPA-T8	BioLegend	301033
CD45R A	PE-Cy7	HI100	BD Biosciences	560675
CD8a	PerCP/Cy5.5	RPA-T8	BioLegend	301032
CCR7	PE	150503	BD Biosciences	560765
CD3	APC/Cy7	HIT3a	BioLegend	300318
CD38	APC	HB-7	BioLegend	356606
HLA-DR	PB	L243	BioLegend	307633
CD69	PE-Cy7	FN50	BD Biosciences	557745
TIGIT	PE	MBSA43	eBioscience	12-9500-42
KLRG1	Ax647	SA231A2	BioLegend	367704
CD154	BV421	TRAP1	BD Biosciences	563886
CD137	PE/Cy7	4B4-1	BioLegend	309818
Lag3	PE	3DS223H	eBioscience	12-2239-42
PD1	APC	EH12.2H 7	BioLegend	329908
Tim-3	BV421	F38-2E2	BioLegend	345008

5

## 7. PROCEDURE

### 7.1 Reagent Preparation

#### 7.1.1 FACS Wash Buffer

7.1.1.1 Added 2% (w/v) heat-inactivated FBS to DPBS (Add 10ml FBS to 490mLs of 1X dPBS).

10

7.1.1.2 Added 0.1% (w/v) NaN<sub>3</sub> (76.9ul to 500mL bottle.)

7.1.1.3 Solution was stored at 40°C. Discard after 30 days.

7.1.2 Aqua dye

7.1.2.1 Added 50µl of DMSO to the vial of reactive dye.

5

7.1.2.2 Mixed well and visually confirm that all of the dye has dissolved.

7.1.2.3 Dye that was not used for the procedure was aliquoted and frozen at 20°C until the next use. Did not freeze/thaw a second time.

10

7.1.3 Antibody Cocktail Preparation.

7.1.3.1 Cocktails were made up in polypropylene tubes such as an Eppendorf tube

7.1.3.2 Cocktails were stored for up to 6 months.

Table 26: Differentiation Panel 1 (DF1):

Target	Format	Clone	Supplier	Catalog Number	Titre
TCRab (i.e., TCRα/β)	PE/Cy7	IP26	BioLegend	306720	3
CD57*	PerCP-Cy5.5	HNK-1	BioLegend	359622	2
CD28*	PE	CD28.2	BioLegend	302908	2
CD4	FITC	OKT4	eBioscience	11-0048-42	2
CD27*	APC-H7	M-T271	BD Biosciences	560222	3
CD56	APC	N901	Beckman Coulter	IM2474U	3
CD8a	PB	RPA-T8	BioLegend	301033	2
FACS Buffer					33

15

Table 27: Differentiation Panel 2 (DF2):

Target	Format	Clone	Supplier	Catalog Number	Titre
CD45RA*	PE-Cy7	HI100	BD Biosciences	560675	1
CCD3	PerCP/Cy5.5	SP34-2	BD Biosciences	552852	2

CCCR7*	PE	150503	BD Biosciences	560765	5
CCD8	FITC	HIT8	BioLegend	300906	2
CCD4	APC/Cy7	OKT4	BioLegend	317418	2
CCD38*	APC	HB-7	BioLegend	356606	1
HHLA-DR	PB	L243	BioLegend	307633	2
FACS Buffer					35

Table 28: T-cell Activation Panel 1(Tact1)

Target	Format	Clone	Supplier	Catalog Number	Titre
CD137*	PE/Cy7	4B4-1	BioLegend	309818	2
CD3	PerCP/Cy5.5	SP34-2	BD Biosciences	552852	2
Lag3*	PE	3DS223H	eBioscience	12-2239-42	5
CD8	FITC	HIT8	BioLegend	300906	2
CD4	APCCy7	OKT4	BioLegend	317418	2
PD1*	APC	EH12.2H7	BioLegend	329908	2
Tim-3*	BV421	F38-2E2	BioLegend	345008	2
FACS Buffer					33

5

Table 29: T-cell Activation Panel 2(Tact2)

Target	Format	Clone	Supplier	Catalog Number	Titre
CD69*	PE-Cy7	FN50	BD Biosciences	557745	3
CD3	PerCP/Cy5.5	SP34-2	BD Biosciences	552852	2
TIGIT*	PE	MBSA43	eBioscience	12-9500-42	3
CD8	FITC	HIT8	BioLegend	300906	2
CD4	APCCy7	OKT4	BioLegend	317418	2

KLRG1*	Ax647	SA231A2	BioLegend	367704	1
CD154*	BV421	TRAP1	BD Biosciences	563886	3
<b>FACS Buffer</b>					<b>34</b>

## 7.2 Flow Cytometry Assay Requirements

### 7.2.1 Flow Cytometer Calibration

5 7.2.1.1 The flow cytometer was calibrated on the day of the assay using CST beads following manufacturer's instructions.

7.2.1.2 The operator ensured that the flow cytometer had passed calibration, where performance and baseline checks are valid.

### 7.2.2 Compensation/FMO Controls

10 7.2.2.1 Single color compensation samples were prepared using the BD compensation beads and the ArCTM Amine Reactive Compensation Bead Kit.

15 7.2.2.2 FMO control, cell containing samples were stained with a cocktail of antibodies minus the following single antibody conjugate, CD27, CD28, and CD57.

### 7.2.3 MFI Standardization

7.2.3.1 Cytometer voltages was determined daily with a bead control and target voltage values.

## 7.3 Sample Staining

20 7.3.1 Labeled FACS tube with the Sample ID-DF1, Sample ID-DF2, Sample ID-T1, Sample ID-T2.

25 7.3.2 Labeled one set of FMO controls with CD27-APC-H7, CD28-PE, CD57-PerCPCy5.5, CD45RA-PECy7, CCR7-PE, CD38-APC, CD137-PE7, Lag3-PE, PD1 APC, Tim3-BV421, CD69-PE7, TIGIT-PE, KLRG1-Ax647, and CD154-BV421.

7.3.3 Added 0.5 to 2 million cells to each tube.

7.3.4 QS to 3mLs of 1xPBS to each tube.

7.3.5 Spun the tubes at 400 x g, high acceleration and brake, for 5 minutes.

30 7.3.6 While the samples were centrifuging, prepared the dead cell labeling Aqua dye.

7.3.7 Removed an Aqua aliquot from the freezer and dilute 1/200 in PBS. Keep dark. Add 2uL dye to 198uL DPBS.

7.3.8 Decanted or aspirated the supernatant from step 7.3.5.

- 7.3.9 Added 25uL of Aqua solution from above to samples and FMO controls.
- 7.3.10 Incubated for 15 minutes at Room Temperature (RT) in the dark.
- 5 7.3.11 Note: If cells were initially stored in a protein free media, then a blocking step should be added, such as 5uL TruStain for 10 minutes at room temperature.
- 7.3.12 Added 50uL of antibody cocktails to appropriate tubes.
- 7.3.13 Shook tube rack to mix.
- 7.3.14 Incubated for 15 minutes at RT in the dark.
- 10 7.3.15 Recording starting and ending times. Added 3mL of FACS Wash buffer.
- 7.3.16 Spun tubes at 400 x g, high acceleration and brake, for 5 minutes.
- 7.3.17 When centrifuge spin was complete, decanted or aspirated the supernatant.
- 15 7.3.18 Resuspended cells by sliding the tubes along an empty rack.
- 7.3.19 Added 100uL of 1% ParaFormaldehyde to each tube.
- 7.3.20 Stored at 40C in dark until ready to collect on Flow Cytometer.  
Note: Samples could be stored for up to 72 hours.
- 7.4 L/D Aqua compensation control.
- 20 7.4.1 Labeled FACS tubes as L/D Aqua compensation control.
- 7.4.2 Added one drop of Arc beads to the tube.
- 7.4.3 Added 3µl of L/D Aqua directly to the beads.
- 7.4.4 Incubated the tubes at room temperature in the dark for 10 to 30min.
- 7.4.5 Recorded starting and ending incubation time on the worksheet
- 25 7.4.6 After incubation, added 3ml of FACS Wash to each tube.
- 7.4.7 Spun tubes at 400 x g, high acceleration and brake, for 5 minutes.
- 7.4.8 Decanted or aspirated the supernatant.
- 7.4.9 Resuspended the tubes with 500µl of 1% PFA solution. Added 1 drop of negative bead. Placed at 40°C in dark until collection.
- 30 7.5 Compensation control staining.
- 7.5.1 Labeled FACS tubes as shown in the Post-REP TIL Phenotype worksheet.
- 7.5.2 Added the antibodies as shown in the Post-REP TIL Phenotype worksheet.
- 35 7.5.3 After incubation, added 3mLs of FACS buffer to each tube.
- 7.5.4 Spun tubes at 500g, high acceleration and brake, for 2 minutes.
- 7.5.5 Decanted or aspirated the supernatant.

- 7.5.6 Resuspended the tubes with 500 $\mu$ l of 1% PFA in PBS and stored at 2-80°C in the dark.
- 7.6 Data Acquisition
- 7.6.1 Opened FACSDiva software and login.
- 5 7.6.2 In the cytometer mismatch dialog, clicked “Use CST Settings”.
- 7.6.3 Created a new experiment by clicking on “Experiment” tab and selecting the “Extended Phenotype” template.
- 7.6.4 Double clicked on Target Values experiment and adjusted voltages to reach the target values determined by flow core operator.
- 10 7.6.5 Copied instrument settings and pasted them onto the new experiment.
- 7.6.6 Created a Specimen for each individual and named it appropriately.
- 7.6.7 Created names for the samples according to the labels on their tubes.
- 7.6.8 Gently vortexed or flick with finger before placing the tube in the SIT.
- 7.6.9 Acquired the data under RECORD in the Acquisition board.
- 15 7.6.10 Ran the samples at a speed of less than 7,500 events per second.
- 7.6.11 Collected between 50,000 to 100,000 live events excluding debris.

#### **EXAMPLE 19: PROCESS 2A VERIFICATION PROCESS DEVELOPMENT**

[00799] The experiments in this Example were completed to analyze Process 2A for the  
 20 manufacture of TIL from patient-derived tumors of melanoma and a single breast cancer  
 including the outgrowth of TIL from tumors in a pre-REP procedure, followed by a modified  
 REP. Special emphasis was placed on the establishment of a frozen TIL product and a  
 comparison of the performance of the frozen TIL product against the current fresh TIL  
 product process (Process 1C). This report will demonstrate that similar profiles are observed  
 25 in assessment of fresh and thawed critical quality attributes (cell number, % viability, %  
 CD3+ T-cells, and bead-stimulated gamma interferon (IFN- $\gamma$ ) production) as well as a re-  
 stimulation extended phenotype procedure (reREP) whether the same TIL product is fresh or  
 frozen. Data presented to support this conclusion include proliferation, viability, phenotype,  
 IFN- $\gamma$  release, potency, telomere length, and metabolic activity. The results characterize the  
 30 Process 2A, a shortened pre-REP/REP process followed by the cryopreservation of TIL as  
 well as compare the 2A process to the longer 1C process, as described herein.

[00800] Tumor donor descriptions, processing dates and processing locations can be found  
 in Table 1 below (\*indicates that REP was started using a frozen pre-REP TIL line):

**Table 30: Description of Tumor Donors, Processing Dates And Processing Locations.**

<b>Tumor ID</b>	<b>Tissue Type</b>	<b>Source</b>	<b>Tissue</b>
<b>M1061</b>	<b>Melanoma</b>	<b>MT group</b>	<b>Primary — left lateral foot</b>
<b>M1062</b>	<b>Melanoma</b>	<b>Moffitt</b>	<b>N/A</b>
<b>M1063</b>	<b>Melanoma</b>	<b>MT group</b>	<b>Metastatic C- right groin</b>
<b>M1064</b>	<b>Melanoma</b>	<b>MT group</b>	<b>Metastatic C- left ankle</b>
<b>M1065</b>	<b>Melanoma</b>	<b>Bio Options</b>	<b>Metastatic-Axillary lymph node</b>
<b>EP11001</b>	<b>ER+PR+</b>	<b>MT group</b>	<b>Primary- left breast invasive ductal carcinoma</b>
<b>M1056*</b>	<b>Melanoma</b>	<b>Moffitt</b>	<b>N/A</b>
<b>M1058*</b>	<b>Melanoma</b>	<b>MT group</b>	<b>Metastatic- Stage IIB Right scalp</b>
<b>M1023*</b>	<b>Melanoma</b>	<b>Atlantic Health</b>	<b>Primary-Right axilla</b>

### 3. BACKGROUND INFORMATION

3.1 LN-144 is an immunotherapeutic product for treating patients with metastatic melanoma. The product was composed of autologous tumor-infiltrating T lymphocytes (TIL) obtained from an individual patient following surgical resection of a tumor and expanded ex vivo through cell culture of morcellated tumor fragments (pre-REP) followed by Rapid Expansion of TIL in the presence of high dose IL-2, anti-CD3, and co-stimulatory APC. Following non-myeloablative lympho-depletion preconditioning, the patient received a single infusion of his/her TIL and subsequent intravenous infusions of aldesleukin (IL-2) every 8 hours for a maximum of 6 doses. Studies involving alternative methods of TIL expansion in the setting of Damage Associated Molecular Pattern Molecules (DAMPs) within the tumor microenvironment (TNE) have also demonstrated effective expansion of T-cells useful for therapy (Donia 2014; Sommerville, 2012).

The Process 1C which has been used for commercial production of TIL involves a production schedule that can take ~45-55 days to produce an infusible TIL product which is delivered to an immunodepleted patient within 24 hours. The immunodepletion of the recipient patient must be timed precisely with the harvest of the current TIL product. Delays in harvest or delivery of the fresh product can negatively impact an immunodepleted patient awaiting infusion. Process 2A improved upon Process 1C by decreasing manufacturing lead time and materials, due to the decreased lengths of both pre-REP and REP procedures. In addition, Process 2A increased flexibility for product shipment time. The differences between Process 1C and Process 2A in the pre-REP, REP and harvest of process (see Table 2) includes:

3.1.1 Larger flasks with increased tumor fragment capacity used in the pre-REP procedure.

- 3.1.2 Steps that made use of closed system or which are amenable to future adaptation to a closed system.
- 3.1.3 Decreased number of days in both pre-REP and REP procedures.
- 5 3.1.4 A direct-to-REP approach, which eliminated the need to phenotype pre-REP populations prior to selecting specific populations of pre-REP TIL to proceed to REP.
- 3.1.5 A co-culture with a pre-set number of irradiated, allogeneic PBMC APC in conjunction with anti-CD3 (clone OKT3) calculated for sufficient expansion of TIL.
- 10 3.1.6 An automated cell-washing system for harvest.
- 3.1.7 A CS10-based final formulation that was cryogenically-preserved prior to shipping.

**Table 31: Impact of Process 2A on Process 1C.**

Process Step	Process 1C	Process 2A	Impact
<b>STEP A: Obtain Patient tumor sample</b>	<ul style="list-style-type: none"> <li>After surgery, can be frozen after harvest and before Step B.</li> </ul>	<ul style="list-style-type: none"> <li>After surgery, can be frozen after harvest and before Step B.</li> </ul>	<ul style="list-style-type: none"> <li>Same.</li> </ul>
<b>STEP B: First Expansion</b>	<ul style="list-style-type: none"> <li>Physical fragmentation</li> <li>4 fragments per 10 G-REX -10 flasks</li> <li>11-21 day duration</li> <li>Growth media medium comprises IL-2</li> </ul>	<ul style="list-style-type: none"> <li>Physical fragmentation</li> <li>40 fragments per 1 G-REX -100M flask</li> <li>11 day duration (3 days to 14 days range)</li> <li>Growth media medium comprises IL-2</li> </ul>	<ul style="list-style-type: none"> <li>Increased tumor fragments per flask</li> <li>Shortened culture time</li> <li>Reduced number of steps</li> <li>Amenable to closed system</li> </ul>
<b>STEP C: First Expansion to Second Expansion Transition</b>	<ul style="list-style-type: none"> <li>Step B TILs are frozen until phenotyped for selection then thawed to proceed to Step D (~day 30)</li> <li>Step D requires <math>&gt;40 \times 10^6</math> TIL</li> <li>6 G-REX -100M flasks on Step D day 0</li> <li><math>5 \times 10^6</math> TIL and <math>5 \times 10^8</math> antigen presenting cell feeders per flask on Step D day 0</li> </ul>	<ul style="list-style-type: none"> <li>Step B TILs directly move to Step D on Step B day 11</li> <li>Step D requires 25-<math>200 \times 10^6</math> TIL</li> <li>1 G-REX -500M flask on Step B day 11</li> <li><math>25-200 \times 10^6</math> TIL and <math>5 \times 10^9</math> antigen presenting cell feeders on Step B day 11</li> <li>Split to <math>\leq 6</math> G-REX - 500M flasks on day 16</li> </ul>	<ul style="list-style-type: none"> <li>Shortened pre-REP-to-REP process</li> <li>Reduced number of steps</li> <li>Eliminated phenotyping selection</li> <li>Amenable to closed system</li> </ul>
<b>STEP D: Second Expansion</b>	<ul style="list-style-type: none"> <li>Split to 18-36 flasks on Step D day 7</li> <li>14 day duration for Step D</li> <li>Growth media medium comprises IL-2, OKT-3, and antigen-presenting cells</li> </ul>	<ul style="list-style-type: none"> <li>11 day duration for Step D</li> <li>Growth media medium comprises IL-2, OKT-3, and antigen-presenting cells</li> </ul>	<ul style="list-style-type: none"> <li>Reduced number of steps</li> <li>Shorter REP duration</li> <li>Closed system transfer of TIL between flasks</li> <li>Closed system media exchanges</li> </ul>

Process Step	Process 1C	Process 2A	Impact
<b>STEP E: Harvest TILS</b>	<ul style="list-style-type: none"> <li>TIL harvested via centrifugation</li> </ul>	<ul style="list-style-type: none"> <li>TIL harvested via LOVO automated cell washing system</li> </ul>	<ul style="list-style-type: none"> <li>Reduced number of steps</li> <li>Automated cell washing</li> <li>Closed system</li> <li>Reduced loss of product during wash</li> </ul>
<b>STEP F: Final Formulation/ Transfer to Infusion Bag</b>	<ul style="list-style-type: none"> <li>Fresh product in Hypothermosol</li> <li>Single infusion bag</li> <li>Limited shipping stability</li> </ul>	<ul style="list-style-type: none"> <li>Cryopreserved product in PlasmaLyte-A + 1% HSA and CS10 stored in LN2</li> <li>Multiple aliquots</li> <li>Longer shipping stability</li> </ul>	<ul style="list-style-type: none"> <li>Shipping flexibility</li> <li>Flexible patient scheduling</li> <li>More timely release testing</li> </ul>
<b>Overall Estimated Process Time</b>	<ul style="list-style-type: none"> <li>43-55 days from Step A through Step E</li> </ul>	<ul style="list-style-type: none"> <li>22 days from Step A through Step E</li> </ul>	<ul style="list-style-type: none"> <li>Faster turnaround to patient</li> <li>Decreased clean room throughput</li> <li>Decreased Cost of Goods</li> </ul>

#### 4. ABBREVIATIONS

µg	microgram
µl	microliter
µm	micrometer
APC	Antigen presenting cells
CD	Cluster of Differentiation
CM	Central memory
CM1, CM2,	Culture Media 1, 2
CO2	Carbon dioxide
CS10	CryoStor® CS10 cryopreservation medium (BioLife Solutions)
Ct	PCR threshold cycle
DAMPs	Damage Associated Molecular Pattern molecules
dCt	Difference between reference Ct value and test Ct value
ddCt	Difference between dCt and 10ng standard Ct value
ECAR	Extracellular acidification rate (measure of glycolysis)
EM	Effector memory
ER+/PR+	Estrogen Receptor+/Progesterone Receptor+
GMP	Good Manufacturing Practices
HBSS	Hanks Balanced Salt Solution
HSA	Human serum albumin
IFN-γ	Interferon gamma
IL	Interleukin

IU	International units
LN2	Liquid nitrogen
ml	milliliter
Mm	millimeter
ND	Not determined
Ng	Nanogram
°C	degrees Celsius
OCR	Oxygen consumption rate (measure of oxidative phosphorylation)
OKT3	Clone designation of anti-CD3 monoclonal antibody
PBMC	Peripheral Blood Mononuclear Cells
PD	Process Development
REP	Rapid Expansion Protocol
Rh	Recombinant human
SOP	Standard operating procedure
T/S	Telomere repeat copy number to single gene copy number ratio
TIL	Tumor Infiltrating Lymphocyte
VDJ	Variable, diversity, and joining segments of the T cell receptor
V $\alpha$ , V $\beta$	The mature T cell receptor variable region segments in the predominant Tumor Infiltrating Lymphocyte
$\mu$ g	microgram
$\mu$ l	microliter
$\mu$ m	micrometer
APC	Antigen presenting cells
CD	Cluster of Differentiation
CM	Central memory
CM1, CM2,	Culture Media 1, 2
CO <sub>2</sub>	Carbon dioxide
CS10	CryoStor® CS10 cryopreservation medium (BioLife Solutions)
Ct	PCR threshold cycle
DAMPs	Damage Associated Molecular Pattern molecules
dCt	Difference between reference Ct value and test Ct value
ddCt	Difference between dCt and 10ng standard Ct value

ECAR	Extracellular acidification rate (measure of glycolysis)
EM	Effector memory
ER+/PR+	Estrogen Receptor+/Progesterone Receptor+
GMP	Good Manufacturing Practices
HBSS	Hanks Balanced Salt Solution
HSA	Human serum albumin
IFN- $\gamma$	Interferon gamma
IL	Interleukin
IU	International units
LN2	Liquid nitrogen
ml	milliliter
mm	millimeter
ND	Not determined
ng	Nanogram
$^{\circ}\text{C}$	degrees Celsius
OCR	Oxygen consumption rate (measure of oxidative phosphorylation)
OKT3	Clone designation of anti-CD3 monoclonal antibody
PBMC	Peripheral Blood Mononuclear Cells
PD	Process Development
REP	Rapid Expansion Protocol
Rh	Recombinant human
SOP	Standard operating procedure
T/S	Telomere repeat copy number to single gene copy number ratio
TIL	Tumor Infiltrating Lymphocyte
VDJ	Variable, diversity, and joining segments of the T cell receptor
V $\alpha$ , V $\beta$	The mature T cell receptor variable region segments in the predominant Tumor Infiltrating Lymphocyte

## 5. EXPERIMENTAL DESIGN

### 5.1 Process 2A

5.1.1 **Pre-REP:** Upon receipt, the tumor was transferred to a Biological Safety Cabinet (Class II, Type A2). Using sterile technique, the tumor is removed from the shipping container and washed in HBSS

5 containing 50µg/mL gentamicin. The technician morcellates the tumor into 40 x 3X3X3mm fragments which are transferred to a G-REX -100M flask containing pre-warmed CM1 media supplemented with 6000 IU/mL rhIL-2. The flask is placed in a 37°C, 5% CO2 humidified tissue culture incubator for 11 days. If the tumor generates more than 40 fragments, then more than one G-REX -100M may be set up. Cells are then harvested and prepared for the REP.

10 5.1.2 **REP:** On Day 11, one G-REX -500M flask containing 5L of CM2 supplemented with 3000 IU/mL rhIL-2, 30ng/mL anti-CD3 (Clone OKT3) and 5 x 10<sup>9</sup> irradiated allogeneic feeder PBMC cells is prepared. TIL harvested from the pre-REP G-REX -100M flask after volume reduction are counted and seeded into the G-REX -500M flask at a density that can range between 5 x 10<sup>6</sup> and 200 x 10<sup>6</sup> cells. The flask is then placed in a humidified 37°C, 5% CO2 tissue culture incubator for five days. On Day 16, volume of the G-REX -500M flask is reduced, TIL are counted and their viability determined. At this point, the TIL are expanded into multiple G-REX -500M flasks (up to a maximum of six flasks), each with a seeding density of 1 x 10<sup>9</sup> TIL/flask. All flasks are then placed in humidified 37°C, 5% CO2 tissue culture incubators for an additional six days. On Day 22, the day of harvest, each flask is volume reduced by 90%, the cells are pooled together and filtered through a 170µm blood filter, and then collected into a 3L Origin EV3000 bag or equivalent in preparation for automated washing using the LOVO.

25 5.1.3 **Harvest and Final Formulation:** TIL are washed using the LOVO automated cell processing system which replaces 99.99% of cell culture media with a wash buffer consisting of PlasmaLyte-A supplemented with 1% HSA. The LOVO operates using spinning filtration membrane technology that recovers over 92% of the TIL while virtually eliminating residual tissue culture components, including serum, growth factors, and cytokines, as well as other debris and particulates. After completion of the wash, a cell count is performed to determine the expansion of the TIL and their viability upon harvest. CS10 is added to the washed TIL at a 1:1 volume:volume ratio to achieve the Process 2A final formulation. The final formulated product is aliquoted into cryostorage bags, sealed, and placed in pre-cooled aluminum cassettes. Cryostorage bags containing TIL are then frozen using a CryoMed Controlled Rate Freezer (ThermoFisher Scientific, Waltham, MA) according to SOP LAB-018 Rev 000 Operation of Controlled Rate Freezer.

40 5.2 **TIL Samples:** Four conditions of TIL were collected for characterization comparison.

5.2.1 Fresh harvested TIL (direct from PlasmaLyte-A with 1% HSA wash buffer) Thawed TIL (direct from thawed final product bag)

- 5.2.2 Fresh Extended Phenotype reREP TIL (fresh harvested TIL cultured for 7-14 days with IL-2, PBMC feeders, and anti-CD3 clone OKT3)
- 5.2.3 Thawed Extended Phenotype TIL (thawed TIL cultured for 7-14 days with IL-2, PBMC feeders, and anti-CD3 clone OKT3)
- 5 5.3 **Testing Overview** (See Figure 2)
- 5.3.1 **Pre-REP testing** includes evaluating the quantity of IL-2 and analyzing cell culture metabolites such as glucose, lactic acid, L-glutamine and ammonia throughout the pre-REP.
- 10 5.3.1.1 **IL-2 quantification:** media was periodically removed from pre-REP culture and tested by ELISA for IL-2 quantification. Reference R&D Systems Human IL-2 Quantikine ELISA Kit manufacturer's instructions.
- 15 5.3.1.2 **Cell culture metabolite analysis:** media was periodically removed from pre-REP culture and tested for the following metabolites: glucose, lactic acid, L-glutamine and ammonia. Reference the Roche Cedex Bioanalyzer user manual for instructions.
- 20 5.3.2 **REP testing** included extended assays such as cell counts, % viability, flow cytometric analysis of cell surface molecules, potency (IFN- $\gamma$  production), bioluminescent redirected lysis assay, granzyme B production, cellular metabolism and telomere length measurement.
- 25 5.3.2.1 **Cell counts and viability:** TIL samples were counted and viability determined using a Cellometer K2 automated cell counter (Nexcelom Bioscience, Lawrence, MA) according to SOP LAB-003 Rev 000 Cellometer K2 Image Cytometer Automatic Cell Counter.
- 30 5.3.2.2 **Flow cytometric analysis of cell surface biomarkers:** TIL samples were aliquoted for flow cytometric analysis of cell surface markers using the procedure outlined in WRK LAB-041 Rev 000 Surface Antigen Staining of Post REP TIL
- 35 5.3.2.3 **Potency Assay (IFN- $\gamma$  production):** Another measure of cytotoxic potential was measured by determining the levels of the cytokine IFN- $\gamma$  in the media of TIL stimulated with antibodies to CD3, CD28, and CD137/4-1BB. IFN- $\gamma$  levels in media from these stimulated TIL were determined using the WRK LAB-016 Rev 000 Stimulation of TIL to Measure IFN- $\gamma$  Release
- 40 5.3.2.4 **Bioluminescent Redirected Lysis Assay:** The cytotoxic potential of TIL to lyse target cells was assessed using a co-culture assay of TIL with the bioluminescent cell line, P815

(Clone G6), according to the SOP outlined in WRK LAB-040 Bioluminescent Redirected Lysis Assay (Potency Assay) for TIL

5 5.3.2.5 **Granzyme B Production:** Granzyme B is another measure of the ability of TIL to kill target cells. Media supernatants restimulated as described in 5.2.5.3 were also evaluated for their levels of Granzyme B using the Human Granzyme B DuoSet ELISA Kit (R & D Systems, Minneapolis, MN) according to the manufacturer's instructions.

10 5.3.2.6 **Cellular (Respiratory) metabolism:** Cells were treated with inhibitors of mitochondrial respiration and glycolysis to determine a metabolic profile for the TIL consisting of the following measures: baseline oxidative phosphorylation (as measured by OCR), spare respiratory capacity, baseline glycolytic activity (as measured by ECAR), and glycolytic reserve. Metabolic profiles were performed using the procedure outlined in WRK LAB-029 Seahorse Combination Mitochondrial/Glycolysis Stress Test Assay.

20 5.3.2.7 **Telomere length measurement:** Diverse methods have been used to measure the length of telomeres in genomic DNA and cytological preparations. The telomere restriction fragment (TRF) analysis is the gold standard to measure telomere length (de Lange et al., 1990). However, the major limitation of TRF is the requirement of a large amount of DNA (1.5  $\mu$ g). Two widely used techniques for the measurement of telomere lengths namely, fluorescence in situ hybridization (FISH; Agilent Technologies, Santa Clara, CA) and quantitative PCR.

30 5.3.3 Additional samples were taken for the following tests, and could be analyzed in the future as needed:

5.3.3.1 In-depth cytokine analysis

5.3.3.2 TCR sequencing

## 6. RESULTS ACHIEVED

35 A total of 9 experiments were performed using the TIL derived from the tumors described in section 2.3 the experimental design and harvest conditions in section 5.1. TIL harvested using Process 2A were subjected to the testing outlined in section 5.3.2 for the purpose of understanding their ability to expand, their viability, phenotype, cytotoxic

potential, and metabolic profile. All measures were taken for the fresh harvested TIL product and the thawed frozen TIL product (Process 2A).

## 6.1 Cell Counts and Viability

5 6.1.1 Cell counts were taken at the end of the pre-REP, on Day 5 or 6 of the REP (expansion day), and at the end of the REP, both prior to LOVO wash and after LOVO wash. The cell counts were then used to determine the expansion of TIL during the REP and the recovery of TIL after washing on the LOVO. After thaw, the cells were counted again to determine the post-thaw recovery (based on the concentration at which the TIL were frozen) and the post-thaw viability prior to proceeding with other analytical assay. Table 3 summarizes all of these results for the nine Process 2A runs.

**Table 32: Cell counts, % viability, and expansion of TIL from Process 2A runs.**

	M1061T	M1062T	M1063T	M1064T	M1065T	EP11001T	M1056T	M1058T	M1023T
pre-REP Inoculum	$3.3 \times 10^7$	$1 \times 10^8$	$7.5 \times 10^7$	$1.8 \times 10^8$	$4.1 \times 10^6$	$5.4 \times 10^6$	$7 \times 10^7$	$4.7 \times 10^7$	$4.8 \times 10^7$
Day 5/6 Count	$1.3 \times 10^9$	$4 \times 10^9$	$3 \times 10^9$	$3.6 \times 10^9$	$6.6 \times 10^8$	$2.8 \times 10^9$	$4.0 \times 10^9$	$3.7 \times 10^9$	$2.2 \times 10^9$
Fold Expansion from Day 0 to Day 11 Harvest	898	590	470	130	1900	522	771	1400	850
LOVO Recovery (%)	100	68	100	100	92	95	100	90	99
Cryostorage Bags	3 x 30ml	2 x 100ml	2 x 100ml	2 x 50ml	3 x 100ml	2 x 65ml	2 x 100ml	2 x 100ml	2 x 100ml
Post-thaw Recovery (%)	103	84	90	88	101	82	82	86	78
Post-thaw Viability (%)	84.75	84.36	77.15	83.48	79.98	74.85	80.28	85.03	89.21

15

20 6.1.2 Process 2A SOP defines the starting number of TIL for a REP as a range of 5 200 x 10<sup>6</sup> TIL. The range of nine TIL samples used to start the Process 2A REPs was from 4.1 x 10<sup>6</sup> (M1065T) - 1.8 x 10<sup>8</sup> (M1064T), with an average starting TIL number of 6.58 x 10<sup>7</sup>. Interestingly, the REP plated with the lowest number of TIL expanded to the greatest degree at REP harvest (range of expansion for all 9 REPs: 130-1900-fold; average expansion, 840-fold). The average number of TIL harvested at the end of these nine Process 2A REPs was 4.49 x 10<sup>10</sup> (range 7.8 x 10<sup>9</sup> - 6.7 x 10<sup>10</sup>).

25

6.1.3 For comparative statistics of Process 1C, see Chemistry, Manufacturing, and Controls (CMC) Section of Investigational New Drug (IND) Application for LN144/LN-145.

30

6.1.4 Process 1C utilizes manual handling and centrifugation to wash the TIL product. This is time consuming, but more importantly can result

5 in the loss of up to 25% of the product between harvest and final  
 formulation. The automatic cell washing LOVO system provides a way  
 to minimize cell loss and also introduces a closed system wash which  
 decreases the risk of contamination of the product during the wash  
 steps. The recovery of the product following the LOVO wash step of  
 the protocol and showed an average of  $93.8 \pm 10.4\%$  recovery of the  
 TIL product going into the wash step. This statistic includes TIL  
 product for M1062T, which had a LOVO recovery of 68%, during  
 10 which an operator error in the operation of the LOVO resulted in the  
 need to centrifuge the sample and then restart the LOVO procedure  
 (see Section 7, Deviations and Discrepancies). This represents a highly  
 favorable improvement upon the Process 1C washing step on the REP  
 harvest day.

15 6.1.5 Recovery of TIL after the thaw is also a major concern for a frozen  
 TIL product. Recovery of the product was determined by measuring  
 the number of cells recovered from the bag after the thaw compared to  
 the number of cells placed into each freeze bag prior to  
 cryopreservation. The range of recovery from thaw was 78 - 103%,  
 with an average recovery of  $88.2 \pm 8.6\%$ .

20 6.1.6 Though there is a significant difference in the viability of the samples  
 prior to or after thawing, on average, there is only a 2% loss in viability  
 upon thaw. The viability of the TIL going into cryopreservation was  
 $84.3 \pm 4.7\%$ , and the same TIL after thawing had a viability of  $82.1 \pm$   
 25  $4.4\%$  ( $p = 0.0742$ , paired Student's t- test, non-parametric). Release  
 criteria for the fresh clinical TIL Process 1C product requires a  
 minimum of 70% viability. Regardless of a small loss of viability upon  
 thaw, all 9 runs of Process 2A met this release criterion following thaw  
 of the cryogenic product. Table 4 and Figure 3 show the viability of the  
 TIL going into cryopreservation (Fresh + CS10) and the viability of the  
 30 TIL upon thaw.

**Table 33: Comparison of viability of fresh and thawed product.**

	M1061T	M1062T	M1063T	M1064T	M1065T	EP11001T	M1056T	M1058T	M1023T
<b>Fresh + CS10</b>	88.05	84.45	82.05	86.75	76.35	77.9	84.8	87.5	90.5
<b>Thaw</b>	84.75	84.36	77.15	83.48	79.98	74.85	80.28	85.03	89.21

35 6.2 **Re-REP expansion of TIL.** In addition to examining at the ability of the fresh  
 product to expand in a REP, the ability of both the fresh and the thawed TIL  
 product to expand upon restimulation with fresh irradiated allogeneic PBMC  
 feeder APCs and fresh anti-CD3 was evaluated. After 7 days, these  
 restimulated TIL products were analyzed for their ability to expand from  
 initial culture conditions. Figure 4 and Table 5 show the average expansion of  
 re-REP TIL cells after 7 days of growth in culture. Analysis of the data using a  
 40 paired Student's t-test shows that the ability of the TIL to expand in a re-REP

is not significantly different whether starting the REP with a fresh TIL or thawed TIL product ( $p = 0.81$ ).

**Table 34: Comparison of fresh and thawed TIL expansion in re-REP culture**

	M1061T	M1062T	M1063T	M1064T	M1065T	EP11001T	M1056T	M1058T	M1023T
<b>Fresh</b>	139.67	264	227	60.12	24.67	268.83	176	316.33	202.33
<b>Thaw</b>	177.33	110.33	220.67	177.6	220.2	302.5	114.77	190.67	73.82

- 5           6.3   **Cell Culture Metabolites.** One of the major premises of Lion 2A was that less tech time and process transfers would lead to cost savings and limit variability. Possible adverse consequences of this were increases in undesirable metabolites and decreases in nutrient sources. As shown in Figure 5, normal blood values of electrolytes (sodium and potassium), nutrients (glutamine and glucose), and metabolites (lactic acid and ammonia) provide a range to consider when evaluating the results coming out of the 11 day pre-REP. As shown in Figure 6, three TIL (M1061T, M1062T, and M1064T) were evaluated sequentially. In this setting, potassium and sodium were maintained at normal levels, glucose was at  $>1.0\text{g/L}$  and glutamine  $> 0.3 \text{ mmol/L}$ , well above lower normal blood values. As expected lactate rose to as high as  $0.8\text{g/L}$ , about 5X the level found in blood normally and ammonia to as high as  $3\text{mmol/L}$ , as expected from rapidly expanded cells and also substantially higher than what is found normally in the blood.
- 10
- 15
- 20           6.4   **IL-2 Quantification.**
- 25           6.4.1   The main driver of TIL proliferation in the pre-REP in addition to supplemental glucose, glutamine and sufficient oxygenation, is the provision of high levels of rhIL-2. Following its addition to serum containing media, IL-2 levels were measured at  $2\text{-}3.5 \times 10^3 \text{ IU/ml}$ , only falling to about  $1.0 \times 10^3 \text{ IU/ml}$  over the 11 days of culture. This is well above the  $30\text{-}100 \text{ IU/ml}$  necessary to sustain T-cell proliferation. Assessment of IL-2 concentrations using different sources of IL-2 (Prometheus, Akron, Cellgenix) is currently being tested in separate experiments (QP-17-010 : Qualification of IL-2 from Cellgenix, Akron and Prometheus) at Lion Biotechnologies, Tampa.
- 30           6.5   **IFN- $\gamma$  Production**
- 35           6.5.1   After 24hr stimulation of TIL with magnetic anti-CD3, CD28 and 4-1BB Dynabeads as described in sections 5.3.5.3, supernatant from cultures was collected and analyzed for IFN- $\gamma$  using ELISA kits. All restimulated TIL produced more IFN- $\gamma$  than their unstimulated counterparts, showing that the stimulation of the TIL resulted in their activation. Figure 8 shows the ability of the four different TIL compositions (fresh, thaw, fresh re-REP and thaw re-REP TIL) tested to release IFN- $\gamma$  into the surrounding medium upon restimulation.

Tables 6 and 7 show the average values of IFN- $\gamma$  secretion in the 9 Process 2A runs. IFN- $\gamma$  secretion into the surrounding medium upon restimulation is not different between the fresh TIL product and the thawed, cryopreserved TIL. Table 6 shows that fresh product produced an average of  $4143 \pm 2285$  pg IFN- $\gamma$ /10<sup>6</sup> TIL while thawed product produced  $3910 \pm 1487$  pg IFN- $\gamma$ /10<sup>6</sup> TIL ( $p = 0.55$  using paired Student's t-test). If normalized to total TIL product (Table 7), on average, stimulated fresh TIL produced  $86 \pm 61$  grams IFN- $\gamma$ , while thawed stimulated TIL produced  $68 \pm 40$  grams IFN- $\gamma$  ( $p = 0.13$ ). These findings indicate that both fresh and thawed TIL products produce IFN- $\gamma$  and that there is no difference in the ability of either fresh or thawed matching TIL to produce IFN- $\gamma$  upon stimulation with anti-CD3/anti-CD28/anti-4-1BB.

**Table 35: IFN- $\gamma$  secretion in fresh and thawed TIL (expressed as pg/10<sup>6</sup>cells/24hrs)**

	M1061T	M1062T	M1063T	M1064T	M1065T	EP11001T	M1056T	M1058T	M1023T
<b>Fresh</b>	4570	3921	5589	619	1363	4263	6065	2983	7918
<b>Thaw</b>	3158	3543	5478	1563	2127	5059	4216	4033	6010
<b>Fresh Re-REP</b>	3638	1732	971	2676	2753	1461	2374	770	3512
<b>Thaw Re-REP</b>	2970	2060	1273	1074	1744	2522	5042	4038	923

**Table 36: IFN- $\gamma$  secretion in fresh and thawed TIL. All values are in 10<sup>12</sup>(expressed as grams/10<sup>6</sup>cells/24hrs)**

	M1061T	M1062T	M1063T	M1064T	M1065T	EP11001T	M1056T	M1058T	M1023T
<b>Fresh</b>	67.1	78.4	99.6	8.4	4.8	66.1	157.0	109.0	187.0
<b>Thaw</b>	47.7	59.7	87.9	18.7	7.5	64.4	88.9	127.0	111.0

## 6.6 Granzyme B Production

6.6.1 TIL were stimulated with magnetic anti-CD3, CD28 and 4-1BB Dynabeads for 24hr as described in 5.2.5.3, and supernatant from cultures was collected after 24hr and analyzed Granzyme B levels by ELISA. All restimulated TIL produced more Granzyme B than their unstimulated counterparts, showing that the stimulation of the TIL resulted in their activation. Figure 9 shows the ability of the fresh TIL, fresh re-REP TIL, and thawed re-REP TIL to release Granzyme B into the surrounding medium upon restimulation with the cytokine cocktail.

[00801] All products showed granzyme B production ranging from 9190 pg/10<sup>6</sup> viable cells to 262000pg/10<sup>6</sup> viable cells (Table 8). Table 6 shows that fresh product produced an average of  $60644 + 42959$ , while fresh and thawed re-REP produced  $93600 + 67558$  and  $103878 + 84515$  respectively. Comparison between the fresh re-REP and thawed re-REP showed that there is no difference in the ability of the TIL obtained from either conditions ( $p = 0.7$ ). Due

to the lack of Granzyme B measurement in the thawed product, no statistical analysis were performed using the fresh TIL product.

**Table 37: Granzyme B secretion in fresh TIL, fresh reREP TIL, and thawed reREP TIL (expressed as pg/10<sup>6</sup>cells/24hrs)**

	M1061T	M1062T	M1063T	M1064T	M1065T	EP11001T	M1056T	M1058T	M1023T
<b>Fresh</b>	10600	108000	49100	28400	24300	17900	120000	12900	79100
<b>Fresh ReREP</b>	216000	37700	42400	91800	192000	22200	97300	73800	69200
<b>Thaw ReREP</b>	262000	113000	35100	65600	48700	9190	147000	201000	53300

5

### 6.7 Flow cytometric analysis of cell surface biomarkers

[00802] Phenotypic profiling of TILs: Four antibody panels have been standardized at LION to broadly characterize the functional profile of T-cells. These panels were used to assess the immunophenotyping of fresh TIL, thawed TIL, fresh re-REP TIL, and thawed re-REP TIL. All the data used for graphical representation in this section are also provided in a table format (Tables 14-24) in the appendix section 10.

### 6.8 Bioluminescent Redirected Lysis Assay

6.8.1 To determine the potential ability of the Process 2A TIL to kill their target tumor cells, we developed a potency assay involving the co-culture of TIL with a bioluminescent surrogate target cell line P815, as described in section 5.3.2.4. A 4 hour co-culture of the different TIL compositions with P815 in the presence of anti-CD3 stimulation gives a measure of the cytotoxic potential of the TIL cells expressed as LU50, lytic units which can be defined as the number of TIL necessary to kill 50% of the target cells. This measure is then expressed as LU50/106 TIL. Figure 32 below shows the cytotoxic potential of the TIL from the fresh product, and from the two re-REP TIL conditions, fresh re-REP and thaw re-REP.

6.8.2 Comparison of the fresh re-REP to the thaw re-REP shows that there is no significant difference in the ability either TIL to kill a target cell ( $p = 0.3126$ ). This data supports the conclusion that there is no difference between the fresh and the thawed product in terms of the cytotoxic potential of the TIL product. No comparison between fresh was performed as cytotoxic potential was not measured immediately after thawing TIL. Table 9 shows the lytic units of TIL needed to kill 50% of the P815 target cell line.

**Table 38: Lytic units produced by TIL against P815 target cell line**

	Fresh	Fresh reREP	Thaw reREP
<b>M1061T</b>	21.7	42.3	342
<b>M1062T</b>	5.9	17.0	20.9
<b>M1063T</b>	14.2	161	12.5

M10641	22.2	8.7	4.4
M10651	42.6	411	128.8
EP11001T	1.8	4.3	147
M1056T	25.0	16.6	18.2
M10513T	76.9	13.8	16.6
M1023T	30.8	25.6	30.4
avg ± sd	26.8 ± 22.5	20.6 ± 13.3	31.1 ± 37.6

## 6.9 Cellular metabolism profile of TIL

6.9.1 To assess the metabolic health of post-REP TIL, we utilized the Seahorse metabolism analyzer instruments (XFp and XFe96) from Agilent Technologies (Santa Clara, CA) following the protocol outlined in section 5.3.2.6. Briefly, by treating cells with inhibitors that target certain aspects of either oxidative phosphorylation or glycolysis, cells are stressed in such a way that allows for the determination of their SRC and glycolytic reserve. In addition, basal levels of both oxidative phosphorylation (basal OCR) and glycolysis (basal ECAR) can be determined. Finally, because inhibitors of oxidative phosphorylation and glycolysis are combined in the same test, a potential hidden reserve of SRC can be discerned which is only apparent when the cells are treated with the competitive inhibitor of glycolysis, 2-deoxyglucose (2-DG), (labeled SRC2DG), resulting in an increase in SRC which would otherwise remain hidden. This extra respiratory capacity has been labeled as “Covert” SRC. Table 9 shows the metabolic profiles of the fresh harvested TIL, fresh re-REP TIL, and thawed re-REP TIL derived from the metabolic stress test performed on the cells.

6.9.2 **Figures 55A - F** show the data from Table 38 in graphical form. The fresh harvested REP product shows some statistical differences from the fresh re-REP and thawed re-REP products. This is not surprising since the re-REP product has been restimulated with fresh irradiated PBMC APC and fresh anti-CD3 antibody either immediately after the REP or upon thaw. However, in all cases, there is no significant difference between the fresh and thawed products when both are restimulated in a re-REP procedure (see p values of Table 9). This indicates that the cryopreservation process does not detrimentally affect the TIL product. Most notably, for oxidative phosphorylation, the re-REP products have higher SRC than their matching fresh harvest REP products. For glycolysis, the re-REP TIL have statistically significantly higher basal levels of glycolysis and conversely statistically lower levels of glycolytic reserve than fresh REP product. It is worth noting that this could indicate that the re-REP TIL are more highly activated than the freshly harvested TIL, as activated, healthy TIL are reported to possess high levels of glycolytic activity (Buck et al., JEM 212:1345-1360; 2015).

Table 39: Metabolic Profile of Process 2A TIL

Basal OCR, pmol/min	M1061	M1062	M1063	Moff2	Moff3	Moff4	EP110011	M1064	M1065	avg	sd	p v. fresh	p v. fresh REP
PLLA	50.33	33.95	74.89	36.80	38.48	39.89	63.02		55.89	49.16	14.56		
fresh re-REP	38.92	38.48	54.35	25.98	18.68	38.61	37.33	41.04		36.67	10.57	0.03	
thaw re-REP	39.25	43.28	60.05	30.68	57.90	59.08	27.85	52.58	32.82	44.83	12.90	0.48	0.11
Overt SRC, pmol/min													
PLLA	24.74	10.45	101.18	47.32	77.00	35.07	31.39		3.02	41.27	33.22		
fresh re-REP	51.72	36.46	48.24	28.34	37.69	21.02	9.93	99.71		41.64	27.17	0.29	
thaw re-REP	47.38	40.40	121.86	26.04	37.32	86.47	58.45	89.59	56.45	62.66	30.75	0.16	0.12
SRC20G, pmol/min													
PLLA	14.01	5.72	35.98	29.97	74.62	24.42	31.39		20.70	29.60	20.67		
fresh re-REP	81.80	78.82	52.73	38.69	92.37	42.35	-12.81	137.15		63.89	44.45	0.08	
thaw re-REP	76.97	77.72	177.48	48.27	56.57	69.05	74.14	130.76	85.89	88.54	40.59	0.00	0.25
Covert SRC, pmol/min													
PLLA	0.00	0.00	0.00	0.00	0.00	0.00	0.00		17.68	2.21	6.25		
fresh re-REP	30.08	42.36	4.50	10.35	54.68	21.33	0.00	2.63		20.74	20.13	0.02	
thaw re-REP	29.59	37.32	55.62	22.23	19.25	0.00	15.68	41.16	29.44	27.81	16.10	0.01	0.52
Basal ECAR, mpH/min													
PLLA	53.44	27.55	136.33	48.72	89.80	62.29	108.38		72.07	74.82	35.20		
fresh re-REP	96.48	96.63	171.47	102.87	145.19	153.97	35.60	147.02		118.65	44.19	0.10	
thaw re-REP	143.35	173.93	193.39	149.19	169.21	73.17	98.64	96.37	90.55	131.98	43.15	0.01	0.38
Glycolytic Reserve, mpH/min													
PLLA	32.11	26.18	52.00	19.09	38.01	39.03	43.14		76.43	40.75	17.61		
fresh re-REP	24.06	8.75	18.17	-8.28	-5.89	10.31	35.34	20.80		12.91	14.85	0.003	
thaw re-REP	15.50	-18.94	13.56	-6.78	11.45	54.84	-21.37	-12.66	-5.47	3.35	23.75	0.01	0.47

- 5 6.9.3 A direct comparison of fresh to frozen products using the re-REP procedure has enabled us to determine that both the fresh and frozen TIL products, upon identical stimulation conditions, result in metabolic profiles that are statistically indistinct. Both fresh re-REP and thawed re-REP TIL have similar levels of basal respiration (Figure 60A,  $36.7 \pm 10.6$  and  $44.8 \pm 12.9$  pmol/min, respectively;  $p = 0.11$ ) as well as similar (overt) SRC (Figure 60B,  $41.6 \pm 27.2$  and  $62.7 \pm 30.8$ ;  $p = 0.12$ ). Upon treatment of these re-REP cells with 2-DG, the competitive inhibitor to glucose, which results in an inhibition of glycolysis, we see that both fresh and thawed re-REP TIL show an extra, “hidden” spare respiratory capacity (SRC2DG; Covert SRC) that is mostly low or absent in the fresh harvested TIL sample (Figure 60C); only one sample had high levels of SRC2DG (Figure 60C) in the fresh harvested TIL, while conversely, only one of seven samples tested showed a lack Covert SRC upon re-REP. Covert SRC (Figure 60D) for fresh re-REP averaged  $20.7 \pm 20.1$  while covert SRC (Figure 60D) for thawed re-REP ranged from  $27.8 \pm 16.1$ ;  $p = 0.52$ .
- 10
- 15
- 20 6.9.4 The most striking metabolic readout of the extended phenotype (re-REP) TIL is the consistently high levels of basal glycolysis of the extended phenotype (re-REP) samples. Basal glycolysis (Figure 60E) is consistently high in re-REP samples, averaging  $118.7 \pm 44.2$  mpH/min in the fresh re-REP and  $132.0 \pm 43.2$  mpH/min in the thawed re-REP. These samples are not statistically different from each other ( $p = 0.38$ ). However, as mentioned above, the fresh harvested sample does not possess such high basal levels of glycolysis. Compared to fresh re-REP TIL, this difference is substantial, but not significant ( $p = 0.10$ ); however when compared to the thawed re-REP samples, the difference is significant ( $p 0.01$ ). These re-REP cells are apparently heavily reliant on glycolysis for their energy needs, as they have little glycolytic reserve remaining when stressed in the Seahorse metabolic tests (Figure 60F): fresh re-REP TIL average  $12.9 \pm 14.9$  mpH/min; thawed re-REP TIL,  $3.35 \pm 23.8$  mpH/min). These re-REPs are not different from each other ( $p = 0.47$ ) but both are statistically different than the glycolytic reserve found in fresh harvested TIL samples, which averages  $40.8 \pm 17.6$  mpH/min ( $p = 0.003$  and  $0.01$  compared to fresh re-REP and thawed re-REP TIL, respectively). Further studies should be conducted to determine the cause behind the differences seen in glycolysis between these fresh harvest and re-REP TIL samples.
- 25
- 30
- 35

## 6.10 Telomere Length Measurement

- 40 6.10.1 Measurement of Telomere Length of Post REP TIL by Flow Fish and qPCR.

- 45 6.10.1.1 Flow-FISH was performed using Dako/Agilent Pathology Solutions (Telomere PNA Kit/FITC for Flow Cytometry) kit and the manufacturer’s instructions were followed to measure the average length of the Telomere repeat. 1301 T-

cell leukemia cell line (Sigma-Aldrich, St. Louis, MO)) was used as an internal reference standard in each assay. Individual TIL were counted and mixed with 1301 cells at a 1:1 cell ratio. 2 X 10<sup>6</sup> TIL were mixed with 2 X 10<sup>6</sup> 1301 cells. In situ hybridization was performed in hybridization solution (70% formamide, 1% BSA, 20mM Tris, pH 7.0) in duplicate and in the presence and absence of a FITC-conjugated Telomere PNA probe (FITC-00-CCCTAA-CCC-TAA-CCC-TAA) complementary to the telomere repeat sequence at a final concentration of 60nM. After addition of the Telomere PNA probe, cells were incubated for 10 minutes at 82°C in a heat block. The cells were then placed in the dark at room temperature overnight. The next morning, excess telomere probe was removed by washing 2 times for 10 minutes each on a heat block at 40°C with Wash Solution. Following the washes, DAPI (Invitrogen, Carlsbad, CA) was added at a final concentration of 75ng/ml. DNA staining with DAPI was used to gate cells in the G0/G1 population. Sample analysis was performed using a Yeti flow cytometer (Propel-Labs, Fort Collins, CO). Telomere fluorescence of the test sample was expressed as a percentage of the fluorescence (fl) of the 1301 cells per the following formula: Relative telomere length = [(mean FITC fl test cells w/ probe - mean FITC fl test cells w/o probe) X DNA index of 1301 cells X 100] / [(mean FITC fl 1301 cells w/probe - mean FITC fl 1301 cells w/o probe) X DNA index of test cells].

6.10.1.2 **qPCR:** Real time qPCR was used to measure relative telomere length. Briefly, the telomere repeat copy number to single gene copy number (T/S) ratio was determined using an Bio--Rad PCR thermal cycler (Bio-Rad Laboratories, Hercules, CA) in a 96-well format. Ten nanograms of genomic DNA was used for either telomere (Tel) or hemoglobin (hgb) PCR reaction and the primers used were as follows: Tel-1b primer (CGG TTT GTT TGG GTT TGG GTT TGG GTT TGG GTT TGG GTT), Tel-2b primer (GGC TTG CCT TAC CCT TAC CCT TAC CCT TAC CCT TAC CCT), hgb1 primer (GCTTCTGACACAACACTGTGTTCACTAGC), and hgb2 primer (CACCAACTTCATCCACGTTCAACC). All samples were analyzed by both the telomere and hemoglobin reactions, and the analysis was performed in triplicate on the same plate. In addition to the test samples, each 96-well plate contained a five-point standard curve from 0.08ng to 250ng using genomic DNA isolated from 1301 cells. The T/S ratio (-dCt) for each sample was calculated by subtracting the median hemoglobin threshold cycle (Ct) value from the median telomere Ct value. The relative T/S

ratio (-ddCt) was determined by subtracting the T/S ratio of the 10 ng standard curve point from the T/S ratio of each unknown sample.

5  
10  
15  
20

6.10.1.3 **Telomere Length Results and Discussion:** Telomeres are caps (repetitive nucleotide sequences) at the end of the linear chromosomes which play a critical role in facilitating complete chromosome replication. Telomere measurement is an emerging tool in the study of such conditions as degenerative diseases, cancer, and aging. Previous studies from NIH (J Immunol. 2005, Nov 15;175(10):7046-52; Clin Cancer Res. 2011, Jul 1; 17(13): 4550– 4557) have shown that longer telomere length of TIL is associated with clinical response. Conversely, Radvanyi's group found no significant difference in the telomere length of TIL between responders and non-responders (Clin Cancer Res; 18(24); 6758–70). Thus far, there is no evidence to prove that telomere length is associated with the length of in vitro T cell culture. It is possible that post-REP TIL cultured by Process 2A (22 day culture) will have longer telomere length when compared to TIL cultured by Process 1C process (25-36 day culture).

## 7. DISCREPANCIES AND DEVIATIONS

### 7.1 Process Deviations

- 25
- 7.1.1 M1061T: REP cells were split on Day 6 into 4 G-Rex500M flasks.
- 7.1.2 M1062T: REP cells were split on Day 6 into 4 G-Rex500M flasks. Due to an operator error on the LOVO filtration system, an emergency stop occurred during the procedure which required a manual collection of the TIL from the disposable kit. The TIL were successfully filtered during a second LOVO run.
- 30
- 7.1.3 M1063T: No deviations M1064T: No deviations
- 7.1.4 M1065T: Pre-REP cells were below specification for cell count on Day 11 (<5 x 10<sup>6</sup> cells) but were continued into the REP. On REP Day 6, the cells were counted and placed back into the G-Rex500M and fed with 4.5L fresh media. The TIL were not expanded on this day due to insufficient cell count (<1 x 10<sup>9</sup> cells on REP Day 6).
- 35
- 7.1.5 EP11001T: No deviations
- 7.1.6 M1056T: Pre-REP cells were cultured at LION in a G-Rex 100 flask for up to 21 days. Tumor fragments were filtered out on pre-REP Day 11 and the TIL were frozen down on day of harvest in 100% CS10 at 30 x 10<sup>6</sup> cells per 1.5 ml vial. Frozen TIL were thawed at Moffitt PD in CM1 supplemented with 6000 IU/mL rhIL-2 and rested for 3 days
- 40

before initiating Day 0 of the REP. On REP Day 6, TIL were expanded into 4 flasks which proceeded to harvest on REP Day 11.

5 7.1.7 M1058T: Pre-REP cells were cultured at LION in a G-Rex 100 flask for up to 21 days. Tumor fragments were filtered out on pre-REP Day 11 and the TIL were frozen down on day of harvest in 100% CS10 at 30 x 10<sup>6</sup> cells per 1.5 ml vial. Frozen TIL were thawed at Moffitt PD in CM1 supplemented with 6000 IU/mL rhIL-2 and rested for 3 days before initiating Day 0 of the REP. On REP Day 6, cells were split into 4 flasks which proceeded to harvest on REP Day 11.

10 7.1.8 M1023T: Pre-REP cells were cultured at LION in G-Rex10 flasks for up to 21 days. Tumor fragments were filtered out on pre-REP Day 11 and the TIL were frozen down on day of harvest in 100% CS10 at 30 x 10<sup>6</sup> cells per 1.5ml vial. Frozen TIL were thawed at Moffitt PD in CM1 supplemented with 6000 IU/mL rhIL-2 and rested for 3 days prior to initiating Day 0 of the REP. On REP Day 6, cells were expanded into 4 flasks which proceeded to harvest on REP Day 11.

## 7.2 Testing Deviations

7.2.1 In-depth cytokine analysis and TCR sequencing were not performed

## 8. CONCLUSIONS AND RECOMMENDATIONS

20 8.1 **Developing a More Robust Process.** The challenge to Lion was to convert the earlier Lion Process 1C, which had a long processing time, to a potentially more commercializable Lion Process 2A which utilizes refinements resulting in shorter processing time and a cryopreserved final formulation of the TIL product. To this end, nine Process Development runs were conducted to confirm that the old and new processes demonstrated comparable cell yields and comparable TIL potency and phenotype. Of particular note was the 25 markedly decreased complexity of the overall process, resulting in a 50% reduction in the overall length of the pre-REP and REP processes, yet still resulting in comparable TIL yields (7.8 x 10<sup>9</sup> - 67 x 10<sup>9</sup> cells) compared to the historic Lion Process 1C currently practiced at our contract manufacturer. This was recently updated for the June 2017 ASCO presentation (Mean: 41.04 x 10<sup>9</sup> cells with a range of 1.2-96 x 10<sup>9</sup> cells). In addition, Lion has 30 successfully developed a cryopreserved TIL product which demonstrated a post-thaw recovery of 78-103% with >70% viability of TIL, consistent with current Process 1C release criteria (see Table 2).

35 8.2 **The Role of the Extended Phenotypic Analysis (Re-REP).** The ability to proliferate in response to mitogenic stimulation (as in the experimental re-REPs presented in this report) is a critical quality attribute of TIL. The experiments presented here show that 8/9 thawed TIL products were able to expand >100-fold in one week compared to 7/9 matched fresh TIL products, supporting the comparability of the thawed TIL product to the fresh TIL product (Table 2). Two additional critical quality attributes of TIL are their 40 ability to release IFN- $\gamma$  and/or Granzyme B following cytokine (CD3/CD28/4-

1BB) stimulation. Cytokine stimulation of both the fresh and thawed products resulted in IFN- $\gamma$  release exceeding 2ng/10<sup>6</sup> cells/24 hours in 7/9 fresh products and all thawed products (Figure 35) (see section 6.2 of this report). Granzyme B release (Figure 36) was observed in all 9 process runs. CD4 and CD8 levels (Figure 39 and Figure 40) demonstrated remarkable internal consistency between fresh and thawed TIL products. In addition, analysis of the ability of the TIL to kill a surrogate tumor target cell line (P815, Figure 59) showed that the fresh and thawed TIL possessed similar cytotoxic potential.

8.3 **A Metabolic Stress Test of TIL Reveals Robust Bioenergetics.** An analysis of the metabolic profiles of fresh and thawed TIL products stimulated in a re-REP demonstrated that both fresh and thawed TIL responded similarly to metabolic stress testing and showed no substantive differences in a panel of metabolic characteristics (Table 39). Thus, the cryopreserved Process 2A TIL product can be considered comparable to the fresh Process 1C product based on the four quality attributes of identity, potency, cell number, and viability presented in this report. Assays comparing matched fresh and thawed cells were quite comparable in every assay outlined in this report.

8.4 **Acceptance Criteria:** The intrinsic heterogeneity of TIL products with personalized therapy for each patient reflects: (1) their unique major histocompatibility complex restricting molecules (the most polymorphic gene products in human biology); (2) the unique evolutionary trajectory of individual tumors arising in the tumor microenvironment with genomic instability and unique individual driver and passenger mutations; and (3) the heterogeneity conferred by allelic variation, N-region diversity, and VDJ rearrangements in the V $\alpha$  and V $\beta$  segments defining the T-cell receptors used for recognition of neopeptides shared tumor-testis antigens, and virally encoded products. Assessing additional variation occurring as the result of process changes is thus a daunting task and requires assessment of as many parameters as possible to assure oneself that ‘comparability’ of an intrinsically heterogeneous material as possible. This has been accomplished by faithfully examining several acceptance criteria for feasibility and comparability as detailed in the Table 40 below.

**Table 40: Acceptance criteria for feasibility and comparability**

Sampling Point	Parameter	Test Method	Acceptance Criteria for Feasibility	Acceptance Criteria for Comparability
	Total Viable Cells	Automated Cell Counter with AOPI	$\geq 1.5 \times 10^9$ viable cells	No statistical significance between fresh and frozen ReREP arms (p-value < 0.05)
	% Viability	Automated Cell Counter with AOPI	$\geq 70\%$ viable	No statistical significance between fresh and frozen ReREP arms (p-value < 0.05)

Sampling Point	Parameter	Test Method	Acceptance Criteria for Feasibility	Acceptance Criteria for Comparability
Day 22	Purity	Flow Cytometry	≥90% T-cells	No statistical significance between fresh and frozen ReREP arms (p-value<0.05)
		TCR Sequencing	N/A	N/A
	Potency	IFN $\gamma$ ELISA	≥2x background and ≥400pg/1x10 <sup>6</sup> viable cells/ 24hrs	No statistical significance between fresh and frozen ReREP arms (p-value<0.05)
		Granzyme B ELISA	≥2x background	N/A
		Bioluminescent Redirected Lysis Assay	N/A	N/A
	Respiration	Seahorse Stress Test	N/A	N/A

Based on the feasibility criteria listed in Table 11, TIL will be evaluated on whether or not the requirements were met. All individual criteria were met for each experiment and each TIL line (n=9). Student t-test was used for statistical analysis. Non-parametric student T-test was used to calculate the p-value for % viability as viability measures will not be a Gaussian distribution. See, Table 41 below.

**Table 41: Meeting Feasibility Acceptance Criteria.**

TIL Line	Cell Count		% Viability		Purity (Flow Cytometry)		Potency (IFN $\gamma$ ELISA) pg/1 x10 <sup>6</sup> cells/24h	
	Fresh	Thaw	Fresh	Thaw	Fresh	Thaw	Fresh	Thaw
M1061T	6.48x10 <sup>9</sup>	6.66x10 <sup>9</sup>	88.05	84.93	95.3	91.5	4570	3158
M1062T	6.76x10 <sup>9</sup>	5.70x10 <sup>9</sup>	84.45	83.73	99.7	98.9	3921	3543
M1063T	14.9x10 <sup>9</sup>	13.5x10 <sup>9</sup>	82.05	77.15	98.7	99.6	5589	5478
M1064T	8.06x10 <sup>9</sup>	7.08x10 <sup>9</sup>	86.75	83.36	84.5	89.8	619	1563
M1065T	3.06x10 <sup>9</sup>	3.10x10 <sup>9</sup>	76.35	80.90	96.8	91.4	1363	2127
EP11001T	14.9x10 <sup>9</sup>	12.2x10 <sup>9</sup>	77.9	74.85	90.4	94.3	4263	5059
M1056T	13.1x10 <sup>9</sup>	10.7x10 <sup>9</sup>	84.8	80.20	94.2	94.1	6065	4216
M1058T	23.4x10 <sup>9</sup>	20.1x10 <sup>9</sup>	87.5	85.07	99	96.2	2983	4033

TIL Line	Cell Count		% Viability		Purity (Flow Cytometry)		Potency (IFNy ELISA) pg/1 x10 <sup>6</sup> cells/24h	
	Fresh	Thaw	Fresh	Thaw	Fresh	Thaw	Fresh	Thaw
M1023T	18.4x10 <sup>9</sup>	144x10 <sup>9</sup>	90.5	89.52	96.5	98.8	7918	6010
<b>P value</b>	0.1132		0.0742		0.9855		0.5821	
<b>Significantly different</b>	No		No		No		No	

[00803] Based on the acceptance criteria listed in Table 40, fresh and frozen re-REP TIL were evaluated on whether or not the requirements were met. (Viability not reported since the duration of re-REP was 7 days and residual irradiated PBMC could not be distinguished from TIL.) Numbers in parentheses denote the criteria that were not met. Based on the purity criteria measured using CD3+ expression, 6/9 fresh Re-REP TIL products met the stringent >90% criteria (M1061, M1065 and EP11001 did not) and 8/9 thawed products passed the acceptance criteria even following Re-REP. The low number of CD3+ TIL in EP11001T fresh re-REP might be attributed to extreme downregulation of T cell receptor. Measurement of CD3+ TIL as a measure of purity was not determined for M1023T thaw re-REP TIL. For this TIL composition, purity was estimated using TCRap staining and is denoted by an asterisk (\*). Student-t test was used for the statistical analysis. See, Table 42 below.

**Table 42: Meeting Comparability Acceptance Criteria.**

TIL Line	Cell Count		Purity (Flow Cytometry)		Potency (IFNy ELISA) pg/1x10 <sup>6</sup> cells/24h	
	Fresh Re-REP	Thaw Re-REP	Fresh Re-REP	Thaw Re-REP	Fresh Re-REP	Thaw Re-REP
<b>M1061T</b>	1.40x10 <sup>6</sup>	1.77x10 <sup>6</sup>	<b>(86.1)</b>	99.3	3638	2970
<b>M1062T</b>	2.64x10 <sup>6</sup>	1.10x10 <sup>6</sup>	99.3	97.1	1732	2060
<b>M1063T</b>	2.27x10 <sup>6</sup>	2.21x10 <sup>6</sup>	99.2	97.4	971	1273
<b>M1064T</b>	1.76x10 <sup>6</sup>	1.15x10 <sup>6</sup>	83.8	37.8	2676	1074
<b>M1065T</b>	3.16x10 <sup>6</sup>	1.91x10 <sup>6</sup>	<b>(78.1)</b>	<b>(75.8)</b>	2753	1744
<b>EP11001T</b>	2.02x10 <sup>6</sup>	0.738x10 <sup>6</sup>	<b>(18.2)</b>	85.4	1461	2522

TIL Line	Cell Count		Purity (Flow Cytometry)		Potency (IFN $\gamma$ ELISA) pg/1x10 <sup>6</sup> cells/24h	
	Fresh Re-REP	Thaw Re-REP	Fresh Re-REP	Thaw Re-REP	Fresh Re-REP	Thaw Re-REP
M1056T	0.601x10 <sup>6</sup>	1.78x10 <sup>6</sup>	98.1	96.7	2374	5042
M1058T	0.740x10 <sup>6</sup>	2.20x10 <sup>6</sup>	98.4	99.2	770	4038
M1023T	2.69x10 <sup>6</sup>	3.03x10 <sup>6</sup>	97	39.9*	3512	923
<b>P value</b>	0.6815		0.3369		0.7680	
<b>Significantly different</b>	No		No		No	

### Bibliography

- 5 Goff SL, Dudley ME, Citrin DE, Somerville RP, Wunderlich JR, Danforth DN, Zlott DA, Yang JC, Sherry RM, Kammula US, Klebanoff CA, Hughes MS, Restifo NP, Langhan MM, Shelton TE, Lu L, Kwong ML, Ilyas S, Klemen ND, Payabyab EC, Morton KE, Toomey MA, Steinberg SM, White DE, Rosenberg SA. Randomized, Prospective Evaluation Comparing Intensity of Lymphodepletion Before Adoptive Transfer of Tumor-Infiltrating Lymphocytes for Patients With Metastatic Melanoma. *J Clin Oncol.* 2016 Jul 10;34(20):2389-97. doi: 10.1200/JCO.2016.66.7220. Epub 2016 May 23. PubMed PMID: 27217459; PubMed Central PMCID: PMC4981979.
- 10 Hinrichs CS, Rosenberg SA. Exploiting the curative potential of adoptive T-cell therapy for cancer. *Immunol Rev.* 2014 Jan;257(1):56-71. doi:10.1111/imr.12132. Review. PubMed PMID: 24329789; PubMed Central PMCID: PMC3920180.
- 15 Jin J, Sabatino M, Somerville R, Wilson JR, Dudley ME, Stroncek DF, Rosenberg SA. Simplified method of the growth of human tumor infiltrating lymphocytes in gas-permeable flasks to numbers needed for patient treatment. *J Immunother.* 2012 Apr;35(3):283-92. doi:10.1097/CJI.0b013e31824e801f. PubMed PMID: 22421946; PubMed Central PMCID: PMC3315105.
- 20 Somerville RP, Devillier L, Parkhurst MR, Rosenberg SA, Dudley ME. Clinical scale rapid expansion of lymphocytes for adoptive cell transfer therapy in the WAVE® bioreactor. *J Transl Med.* 2012 Apr 4;10:69.
- 25 Donia M, Larsen SM, Met O, Svane IM. Simplified protocol for clinical-grade tumor-infiltrating lymphocyte manufacturing with use of the Wave bioreactor. *Cytotherapy.* 2014 Aug;16(8):1117-20. doi: 10.1016/j.jcyt.2014.02.004; PubMed PMID: 24831841.
- Henning AL, Levitt DE, Vingren JL, McFarlin BK. Measurement of T-Cell Telomere Length Using Amplified-Signal FISH Staining and Flow Cytometry.

- Curr Protoc Cytom. 2017 Jan 5;79:7.47.1-7.47.10. doi: 10.1002/cpcy.11. PubMed PMID 28055115
- 5 Kelesidis T, Schmid I. Assessment of Telomere Length, Phenotype, and DNA Content. *Curr Protoc Cytom.* 2017 Jan 5;79:7.26.1-7.26.23. doi: 10.1002/cpcy.12. PubMed PMID: 28055113.
- 10 Gardner M, Bann D, Wiley L, Cooper R, Hardy R, Nitsch D, Martin-Ruiz C, Shiels P, Sayer AA, Barbieri M, Bekaert S, Bischoff C, Brooks-Wilson A, Chen W, Cooper C, Christensen K, De Meyer T, Deary I, Der G, Diez Roux A, Fitzpatrick A, Hajat A, Halaschek-Wiener J, Harris S, Hunt SC, Jagger C, Jeon HS, Kaplan R, Kimura M, Lansdorp P, Li C, Maeda T, Mangino M, Nawrot TS, Nilsson P, Nordfjall K, Paolisso G, Ren F, Riabowol K, Robertson T, Roos G, Staessen JA, Spector T, Tang N, Unryn B, van der Harst P, Woo J, Xing C, Yadegarfar ME, Park JY, Young N, Kuh D, von Zglinicki T, Ben-Shlomo Y; Halcyon study team.. Gender and telomere length: systematic review and meta-analysis. *Exp Gerontol.* 2014 Mar;51:15-27. doi:10.1016/j.exger.2013.12.004. Epub 2013 Dec 21. Review. PubMed PMID: 24365661;PubMed Central PMCID: PMC4523138.
- 15 Carbonari M, Tedesco T, Fiorilli M. Correlation between terminal restriction fragments and flow-FISH measures in samples over wide range telomere lengths. *Cell Prolif.* 2014 Feb;47(1):20-7. doi: 10.1111/cpr.12086. PubMed PMID: 24450811.
- 20 Rufer N, Dragowska W, Thornbury G, Roosnek E, Lansdorp PM. Telomere length dynamics in human lymphocyte subpopulations measured by flow cytometry. *Nat Biotechnol.* 1998 Aug;16(8):743-7. PubMed PMID: 9702772.
- 25 Li Y, Liu S, Hernandez J, Vence L, Hwu P, Radvanyi L. MART-1-specific melanoma tumor-infiltrating lymphocytes maintaining CD28 expression have improved survival and expansion capability following antigenic restimulation in vitro. *J Immunol.* 2010 Jan 1;184(1):452-65. doi: 10.4049/jimmunol.0901101. Epub 2009 Nov 30. PubMed PMID: 19949105.
- 30 Rosenberg SA, Dudley ME. Adoptive cell therapy for the treatment of patients with metastatic melanoma. *Curr Opin Immunol.* 2009 Apr;21(2):233-40. doi:10.1016/j.coi.2009.03.002. Epub 2009 Mar 21. Review. PubMed PMID: 19304471; PubMed Central PMCID: PMC3459355.
- 35 Shen X, Zhou J, Hathcock KS, Robbins P, Powell DJ Jr, Rosenberg SA, Hodes RJ. Persistence of tumor infiltrating lymphocytes in adoptive immunotherapy correlates with telomere length. *J Immunother.* 2007 Jan;30(1):123-9. PubMed PMID:17198091; PubMed Central PMCID: PMC2151201.
- 40 Zhou J, Shen X, Huang J, Hodes RJ, Rosenberg SA, Robbins PF. Telomere length of transferred lymphocytes correlates with in vivo persistence and tumor regression in melanoma patients receiving cell transfer therapy. *J Immunol.* 2005 Nov 15;175(10):7046-52. PubMed PMID: 16272366; PubMed Central PMCID: PMC1351312.
- Maciejowski J, de Lange T. Telomeres in cancer: tumour suppression and genome instability. *Nat Rev Mol Cell Biol.* 2017 Mar;18(3):175-186.

doi:10.1038/nrm.2016.171. Epub 2017 Jan 18. Review. PubMed PMID: 28096526.

5 Erdel F, Kratz K, Willcox S, Griffith JD, Greene EC, de Lange T. Telomere Recognition and Assembly Mechanism of Mammalian Shelterin. Cell Rep. 2017 Jan 3;18(1):41-53. doi: 10.1016/j.celrep.2016.12.005. PubMed PMID: 28052260; PubMed Central PMCID: PMC5225662.

Cardenas ME, Bianchi A, de Lange T. A Xenopus egg factor with DNA-binding properties characteristic of terminus-specific telomeric proteins. Genes Dev. 1993 May;7(5):883-94. PubMed PMID: 7684008.

10 de Lange T. Activation of telomerase in a human tumor. Proc Natl Acad Sci U S A. 1994 Apr 12;91(8):2882-5. Review. PubMed PMID: 8159672; PubMed Central PMCID: PMC43476.

15 de Lange T, Shiue L, Myers RM, Cox DR, Naylor SL, Killery AM, Varmus HE. Structure and variability of human chromosome ends. Mol Cell Biol. 1990 Feb;10(2):518-27. PubMed PMID: 2300052; PubMed Central PMCID: PMC360828.

## 9. Additional Tables

**Table 43 - Figure 39: CD4+ cells**

Tumor ID	M1061	M1062	M1063	M1064	M1065	EP11001	M1056	M1058	M1023
Fresh	4.85	34	10.5	41.7	64.9	64.7	4.15	12.3	8.38
Thaw	5.68	33	11.3	49.5	61.7	62.6	3.46	17.9	7.6
Fresh ReREP	8.1	23.5	19.2	39/	31.9	16.3	6.46	12.9	16.7
Thaw ReREP	11	33	15.3	49.3	39.3	26.7	9.51	17.2	19.1

20

**Table 44 - Figure 40: CD8+ cells**

Tumor ID	M1061	M1062	M1063	M1064	M1065	EP11001	M1056	M1058	M1023
Fresh	45.6	54.7	85.8	38.2	28.6	22.3	93.2	84	88.8
Thaw	50.8	55.7	76.7	37	22.8	19	92.9	76.6	84.3
Fresh ReREP	63	48.3	72.4	37.9	47.8	5.87	90.3	74.5	74.4
Thaw ReREP	66.3	46.7	47	21.6	19.1	9.23	82.8	63.7	64.3

**Table 45 - Figure 41: CD4+CD154+ cells and Figure 105: CD8+CD154+ cells**

T cell	Markers	M1061		M1062		M1063		M1064	
		Fresh	Thawed	Fresh	Thawed	Fresh	Thawed	Fresh	Thawed
CD4	CD154+	78.6	nd	nd	nd	93.3	62.1	94	76.2
CD8	CD154+	37.3	nd	nd	nd	85.8	19.9	89.3	61.1

T cell	Markers	M1061		M1062		M1063		M1064	
		Fresh	Thawed	Fresh	Thawed	Fresh	Thawed	Fresh	Thawed
		Re-REP	Re-REP	Re-REP	Re-REP	Re-REP	Re-REP	Re-REP	Re-REP
CD4	CD154+	88.9	84	56	82.1	68.2	93.6	97	90.3
CD8	CD154+	35.6	49	12.5	19	59.1	77.88	0.025	90.1

25

T cell	Markers	M1065		EP11001		M1056		M1058		M1203	
		Fresh	Thawed	Fresh	Thawed	Fresh	Thawed	Fresh	Thawed	Fresh	Thawed

CD4	CD154+	91	87.2	79.1	83.1	89.3	92	90.1	92.6	77.9	66.9
CD8	CD154+	17	20.3	40	36.9	23	27.6	40.5	52.1	17.9	13.7

T cell	Markers	M1065		EP11001		M1056		M1058		M1203	
		Fresh Re-REP	Thawed Re-REP	Fresh Re-REP	Thawed Re-REP	Fresh Re-REP	Thawed Re-REP	Fresh Re-REP	Thawed Re-REP	Fresh Re-REP	Thawed Re-REP
CD4	CD154+	0	91.6	52.1	87.1	77	86.4	92.7	85.1	90.7	81.3
CD8	CD154+	0.00609	61.8	45.3	74.8	47.3	81.7	73.6	78.3	24.2	27.1

**Table 46 - Figure 43: CD4+CD69+ cells and Figure 17: CD8+CD69+ cells**

T cell	Markers	M1061		M1062		M1063		M1064	
		Fresh	Thawed	Fresh	Thawed	Fresh	Thawed	Fresh	Thawed
CD4	CD69+	33.9	nd	nd	nd	82.2	68.8	51.3	84.8
CD8	CD69+	22.4	nd	nd	nd	83	78.3	67.8	78.6

T cell	Markers	M1061		M1062		M1063		M1064	
		Fresh Re-REP	Thawed Re-REP	Fresh Re-REP	Thawed Re-REP	Fresh Re-REP	Thawed Re-REP	Fresh Re-REP	Thawed Re-REP
CD4	CD69+	58.7	69.6	67.6	77.6	77.6	86.7	85.5	78.5
CD8	CD69+	80.9	80	62.7	73.2	87.6	87.9	92.2	88.3

T cell	Markers	M1065		EP11001		M1056		M1058		M1203	
		Fresh	Thawed	Fresh	Thawed	Fresh	Thawed	Fresh	Thawed	Fresh	Thawed
CD4	CD69+	82.7	84.4	78.7	58.3	83.9	84.9	89.7	644.6	33.8	38.7
CD8	CD69+	78.9	72.3	69.5	54.5	80.3	86	68	77.8	41.3	48.8

T cell	Markers	M1065		EP11001		M1056		M1058		M1203	
		Fresh	Thawed	Fresh	Thawed	Fresh	Thawed	Fresh	Thawed	Fresh	Thawed
		Re-REP	Re-REP	Re-REP	Re-REP	Re-REP	Re-REP	Re-REP	Re-REP	Re-REP	Re-REP
CD4	CD69+	90.2	93.2	74.7	39.1	96.1	93.8	91.1	93.7	35.3	80.1
CD8	CD69+	91.3	90.5	87.6	52.9	95.4	94.2	93.1	93.6	71.1	88.1

**Table 47 - Figure 45: CD4+CD137+ cells and Figure 19 CD8+CD137+ cells**

T cell	Markers	M1061		M1062		M1063		M1064	
		Fresh	Thawed	Fresh	Thawed	Fresh	Thawed	Fresh	Thawed
CD4	CD137+	19.8	nd	nd	nd	65.4	30.4	nd	1.31
CD8	CD137+	19.8	nd	nd	nd	65.4	30.4	nd	1.31

T cell	Markers	M1061		M1062		M1063		M1064	
		Fresh	Thawed	Fresh	Thawed	Fresh	Thawed	Fresh	Thawed
		Re-REP	Re-REP	Re-REP	Re-REP	Re-REP	Re-REP	Re-REP	Re-REP
CD4	CD137+	15.4	30.4	73	78.1	62.6	53.2	51.6	64.7
CD8	CD137+	28.8	43.1	39.3	35.3	84.4	85.7	71.1	81

T cell	Markers	M1065		EP11001		M1056		M1058		M1203	
		Fresh	Thawed	Fresh	Thawed	Fresh	Thawed	Fresh	Thawed	Fresh	Thawed
CD4	CD137+	524	7.26	7.78	5.4	4.28	3.65	6.89	4.6	4.28	9.67
CD8	CD137+	3.23	7.26	7.78	5.4	4.28	3.65	6.89	4.6	4.28	9.67

T cell	Markers	M1065		EP11001		M1056		M1058		M1203	
		Fresh	Thawed	Fresh	Thawed	Fresh	Thawed	Fresh	Thawed	Fresh	Thawed
		Re-REP	Re-REP	Re-REP	Re-REP	Re-REP	Re-REP	Re-REP	Re-REP	Re-REP	Re-REP
CD4	CD137+	31.1	24.6	65.1	47.8	221	18.6	61.6	56.9	49.8	50.8
CD8	CD137+	50.9	33.8	57.3	54.6	77.3	78.8	76.9	87	58	50.3

5

**Table 48 - Figure 47: CD4+CM cells and Figure 21 CD8+CM cells**

T Cell	Markers	M1061		M1062		M1063		M1064	
		Fresh	Thawed	Fresh	Thawed	Fresh	Thawed	Fresh	Thawed
CD4	CM	1.08	n/d	0.59	0.29	10.4	2.08	14.4	0.13
CD8	CM	0.37	n/d	0.9	0.17	3.2	0.66	73.2	0.13

T cell	Markers	M1061		M1062		M1063		M1064	
		Fresh	Thawed	Fresh	Thawed	Fresh	Thawed	Fresh	Thawed
		Re-REP	Re-REP	Re-REP	Re-REP	Re-REP	Re-REP	Re-REP	Re-REP
CD4	CM	2.32	7.71	13.8	12.6	13.4	22.3	15.9	18.6
CD8	CM	1.85	9.38	6.48	14.2	15.7	25.7	24.2	25.8

T cell	Markers	M1065		EP11001		M1056		M1058		M1203	
		Fresh	Thawed	Fresh	Thawed	Fresh	Thawed	Fresh	Thawed	Fresh	Thawed
CD4	CM	0.42	0.53	0.48	1.17	1.83	1.5	1.36	1.8	2.45	1.79

CD8	CM	0.21	0.67	2.65	1.79	0.33	0.72	0.91	0.67	1.99	2.22
-----	----	------	------	------	------	------	------	------	------	------	------

T cell	Markers	M1065		EP11001		M1056		M1058		M1203	
		Fresh Re-REP	Thawed Re-REP	Fresh Re-REP	Thawed Re-REP	Fresh Re-REP	Thawed Re-REP	Fresh Re-REP	Thawed Re-REP	Fresh Re-REP	Thawed Re-REP
CD4	CM	7.03	2.28	18.9	3.73	49.6	55.6	20.1	12.6	22.1	12.7
CD8	CM	5.05	1.6	11.4	3.37	25.8	26.4	21.6	19.8	11.1	7.59

**Table 49 - Figure 49: CD4+EM cells and Figure 23 CD8+EM cells**

T cell	Markers	M1061		M1062		M1063		M1064	
		Fresh	Thawed	Fresh	Thawed	Fresh	Thawed	Fresh	Thawed
CD4	EM	90	n/d	98.3	98.9	83.9	97.2	84.1	99.8
CD8	EM	89.1	n/d	80.6	87.9	92.4	97.8	20.8	98.8

T cell	Markers	M1061		M1062		M1063		M1064	
		Fresh Re-REP	Thawed Re-REP	Fresh Re-REP	Thawed Re-REP	Fresh Re-REP	Thawed Re-REP	Fresh Re-REP	Thawed Re-REP
CD4	EM	95.6	84.4	84.5	83.4	84.3	73.7	80.6	80.4
CD8	EM	97.2	87.9	90.8	82.3	82.5	72.2	74.5	73

T cell	Markers	M1065		EP11001		M1056		M1058		M1203	
		Fresh	Thawed	Fresh	Thawed	Fresh	Thawed	Fresh	Thawed	Fresh	Thawed
CD4	EM	99.4	99.4	96.7	97.4	97.1	97.8	97.4	97.6	9.62	95.3
CD8	EM	98.3	98.6	91.8	95.5	98.8	98.9	98.8	99.2	93.9	95.2

T cell	Markers	M1065		EP11001		M1056		M1058		M1203	
		Fresh Re-REP	Thawed Re-REP	Fresh Re-REP	Thawed Re-REP	Fresh Re-REP	Thawed Re-REP	Fresh Re-REP	Thawed Re-REP	Fresh Re-REP	Thawed Re-REP
CD4	EM	91.7	97	74.3	90.7	36.2	25.5	73.9	81.8	73.1	76.4
CD8	EM	91.5	96.1	83	90.8	73.2	71.9	77.1	78.2	84.1	85.1

5

**Table 50 - Figure 51: CD4+CD28+ cells and Figure 25 CD8+CD28+ cells**

T cell	Markers	M1061		M1062		M1063		M1064	
		Fresh	Thawed	Fresh	Thawed	Fresh	Thawed	Fresh	Thawed
CD4	CD28+	4.6	5.85	33.2	37	10.5	11.2	31.9	27.6
CD8	CD28+	30.1	34	24.5	23.1	83.8	49.3	22.5	15.5

T cell	Markers	M1061		M1062		M1063		M1064	
		Fresh Re-REP	Thawed Re-REP	Fresh Re-REP	Thawed Re-REP	Fresh Re-REP	Thawed Re-REP	Fresh Re-REP	Thawed Re-REP
CD4	CD28+	6.75	7.18	21.6	27.8	18.6	15	23	27.6
CD8	CD28+	24.6	17.9	10	6.4	28.6	18.9	15.7	11

T cell	Markers	M1065		EP11001		M1056		M1058		M1203	
		Fresh	Thawed	Fresh	Thawed	Fresh	Thawed	Fresh	Thawed	Fresh	Thawed
CD4	CD28+	41.7	38.2	63.2	59.8	3.97	3.29	12.2	17.5	8.27	7.48
CD8	CD28+	13.4	8.52	14.5	12	53	54.4	56.5	62.1	76.5	80.8

T cell	Markers	M1065	EP11001	M1056	M1058	M1203
--------	---------	-------	---------	-------	-------	-------

		Fresh Re-REP	Thawed Re-REP	Fresh Re-REP	Thawed Re-REP	Fresh Re-REP	Thawed Re-REP	Fresh Re-REP	Thawed Re-REP	Fresh Re-REP	Thawed Re-REP
CD4	CD28+	12.3	15.2	13.3	20	6.22	9.29	12.3	16.5	15.4	17.9
CD8	CD28+	6.9	2.43	2.07	3.75	24	34	27	36.9	42	43.9

**Table 51 - Figure 53: CD4+PD-1+ cells and Figure 27 CD8+PD-1+ cells**

T cell	Markers	M1061		M1062		M1063		M1064	
		Fresh	Thawed	Fresh	Thawed	Fresh	Thawed	Fresh	Thawed
CD4	PD-1+	48.5	nd	nd	nd	77	40.6	nd	22.4
CD8	PD-1+	37.1	nd	nd	nd	56	24.6	nd	14

T cell	Markers	M1061		M1062		M1063		M1064	
		Fresh Re-REP	Thawed Re-REP	Fresh Re-REP	Thawed Re-REP	Fresh Re-REP	Thawed Re-REP	Fresh Re-REP	Thawed Re-REP
CD4	PD-1+	36.8	34.2	15.7	26.7	43.9	66	32.4	14.5
CD8	PD-1+	40.4	35.3	6.3	6.21	18	20.4	35.6	23.2

T cell	Markers	M1065		EP11001		M1056		M1058		M1203	
		Fresh	Thawed	Fresh	Thawed	Fresh	Thawed	Fresh	Thawed	Fresh	Thawed
CD4	PD-1+	7.87	7.23	33.3	28.2	33.9	32.8	41.7	38	22.7	23.8
CD8	PD-1+	1.61	0.72	19.2	12.5	23.8	24.7	78.4	59.8	42.6	36.1

T cell	Markers	M1065		EP11001		M1056		M1058		M1203	
		Fresh Re-REP	Thawed Re-REP	Fresh Re-REP	Thawed Re-REP	Fresh Re-REP	Thawed Re-REP	Fresh Re-REP	Thawed Re-REP	Fresh Re-REP	Thawed Re-REP
CD4	PD-1+	22.4	15.5	40.9	33.4	56	51.3	40.3	32.5	18.9	27.3
CD8	PD-1+	6.49	5.73	29.8	34.6	18.9	15.2	68.6	47	28.9	36.1

5

**Table 52 - Figure 55: CD4+LAG3+ cells and Figure 29 CD8+LAG3+ cells**

T cell	Markers	M1061		M1062		M1063		M1064	
		Fresh	Thawed	Fresh	Thawed	Fresh	Thawed	Fresh	Thawed
CD4	LAG3+	16.8	nd	nd	nd	93.5	37.3	nd	6.8
CD8	LAG3+	74	nd	rid	nd	98.4	81.5	nd	31.8

T cell	Markers	M1061		M1062		M1063		M1064	
		Fresh Re-REP	Thawed Re-REP	Fresh Re-REP	Thawed Re-REP	Fresh Re-REP	Thawed Re-REP	Fresh Re-REP	Thawed Re-REP
CD4	LAG3+	68.3	73.1	35.2	56.9	26.9	27.3	52.6	64
CD8	LAG3+	98.3	98.7	97.1	97.7	89.6	85.1	92.8	94.7

T cell	Markers	M1065		EP11001		M1056		M1058		M1203	
		Fresh	Thawed	Fresh	Thawed	Fresh	Thawed	Fresh	Thawed	Fresh	Thawed
CD4	LAG3+	47.2	30.5	35.5	20.1	25	27.4	48.6	38	14.5	7.65
CD8	LAG3+	85.3	38.7	89.6	64.2	83.4	81.9	93.2	66.3	90.3	71.1

T cell	Markers	M1065		EP11001		M1056		M1058		M1203	
		Fresh Re-REP	Thawed Re-REP	Fresh Re-REP	Thawed Re-REP	Fresh Re-REP	Thawed Re-REP	Fresh Re-REP	Thawed Re-REP	Fresh Re-REP	Thawed Re-REP
CD4	LAG3+	65.8	68.2	40.9	46	44.1	39.1	52.1	51	48.5	17.7

CD8	LAG3+	95.4	97.8	92.4	92.5	97.5	98.4	98.2	98.3	97.7	78.1
-----	-------	------	------	------	------	------	------	------	------	------	------

**Table 53 - Figure 57: CD4+TIM-3+ cells and Figure 31 CD8+TIM-3+ cells**

T cell	Markers	M1061		M1062		M1063		M1064	
		Fresh	Thawed	Fresh	Thawed	Fresh	Thawed	Fresh	Thawed
CD4	TIM3+	89.7	nd	nd	nd	98.3	87.6	nd	43.2
CD8	TIM3+	99	nd	nd	nd	99.4	88.1	nd	47

T cell	Markers	M1061		M1062		M1063		M1064	
		Fresh Re-REP	Thawed Re-REP	Fresh Re-REP	Thawed Re-REP	Fresh Re-REP	Thawed Re-REP	Fresh Re-REP	Thawed Re-REP
CD4	TIM3+	95.3	98	94.5	96.9	90.8	90.2	94.2	82.6
CD8	TIM3+	98.9	98.9	97.3	96.7	97.1	97.7	98.2	95.7

T cell	Markers	M1065		EP11001		M1056		M1058		M1203	
		Fresh	Thawed	Fresh	Thawed	Fresh	Thawed	Fresh	Thawed	Fresh	Thawed
CD4	TIM3+	95	78.8	96.9	91.5	96.4	92.5	88.7	80.1	89.9	82.3
CD8	TIM3+	96.9	50.6	98.8	83	98.3	92.9	96.5	73.6	98.2	88.5

T cell	Markers	M1065		EP11001		M1056		M1058		M1203	
		Fresh Re-REP	Thawed Re-REP	Fresh Re-REP	Thawed Re-REP	Fresh Re-REP	Thawed Re-REP	Fresh Re-REP	Thawed Re-REP	Fresh Re-REP	Thawed Re-REP
CD4	TIM3+	91.1	95.4	94.3	98.7	74	75.4	86.5	87.3	94.4	90.6
CD8	TIM3+	94.9	96.5	96.3	98.3	98	99	97.3	98.6	99	97.7

**5 Table 54 - Figure 61: qPCR and Flow-FISH determination of telomere length repeat**

Tumor ID	M1061	M1062	M1063	M1064	M1065	EP11001	M1056	M1058	M1023
qPCR	0.111878	0.135842	0.149685	0.179244	0.151774	0.137738	0.134904	0.124137	0.086569
Flow-FISH	9.330236	1215041	8.782231	7.174627	8.961553	6112918	9.010615	7.944534	5.766692

**EXAMPLE 20: NOVEL CRYOPRESERVED TUMOR INFILTRATING****10 LYMPHOCYTES (LN-144) ADMINISTERED TO PATIENTS WITH METASTATIC MELANOMA**

[00804] Novel cryopreserved tumor infiltrating lymphocytes (LN-144) administered to patients with metastatic melanoma demonstrates efficacy and tolerability in a multicenter Phase 2 clinical trial

**15 INTRODUCTION:**

[00805] The safety and efficacy of adoptive cell therapy (ACT) with non-cryopreserved tumor infiltrating lymphocytes (TIL) has been studied in hundreds of patients with metastatic melanoma. This multicenter clinical trial was initiated with centrally manufactured TILs (LN-144) as non-cryopreserved and cryopreserved infusion products. Our novel manufacturing process for the non-cryopreserved LN-144 is used in Cohort 1, and a shortened 3 weeks, cryopreserved LN-144 is used in Cohort 2. The Cohort 2 manufacturing offers a significantly shorter process, coupled with a cryopreserved TIL product which allows for flexibility of patient scheduling and dosing. The shorter manufacturing process reduces the wait time for the patient to receive their TIL product and cryopreservation adds convenience to logistics and delivery to the clinical sites.

#### METHODS:

[00806] C-144-01 is a prospective, multicenter study evaluating metastatic melanoma patients who receive LN-144. Following a non-myeloablative lymphodepletion with Cy/Flu preconditioning regimen, patients receive a single infusion of LN-144 followed by the administration of IL-2 (600,000 IU/kg) up to 6 doses. Patients are evaluated for objective response as a primary endpoint for up to 24 months.

#### RESULTS:

[00807] We characterize the cryopreserved LN-144 administered to a second cohort of patients, Cohort 2 (N=10) following the same pre- and post-TIL infusion treatment regimen as used for Cohort 1.

[00808] Cohort 2 patients were heavily pretreated with increased number of prior lines with all patients having anti-CTLA-4 and anti-PD-1 therapies, and larger tumor burden (mean SOD: 15.3, 10.9 cm for Cohorts 2, 1). Median number of prior systemic therapies is 4, 3 for Cohorts 2, 1, respectively. An initial analysis of safety data demonstrates comparable tolerability of cryopreserved LN-144. The safety profile for Cohort 1 patients receiving the non-cryopreserved LN-144 continues to be acceptable for this late stage patient population. The most common TEAEs observed in both cohorts by frequency are nausea, anaemia, febrile neutropenia, neutrophil count decreased, platelet count decreased. Early review of efficacy data indicates anti-tumor activity, including PR, to the TIL therapy observed in patients treated in Cohort 2.

#### CONCLUSIONS:



CM1,2,4	Complete Media 1,2,4
CTS OpTimizer SFM	Cell Therapy System OpTimizer Serum Free Media
g	Grams
Hr	Hour
IFU	Instructions for Use
IL-2	Interleukin-2 Cytokine
Min	Minute
mL	Milliliter
°C	degrees Celsius
PreREP	Pre-Rapid Expansion Protocol
REP	Rapid Expansion Protocol
RT	Room Temperature
SR	Serum Replacement
TIL	Tumor Infiltrating Lymphocytes

## EXPERIMENT DESIGN

[00814] The Pre-REPs and REPs were initiated as mentioned in LAB-008. The overview of this 3 phases of experiment is shown in the chart below:

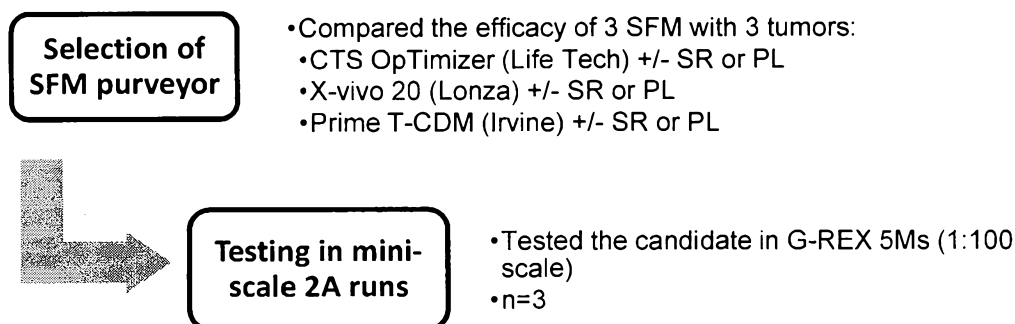

5

[00815] As provide in the chart above, the project was intimated to test the serum free media and supplements in two steps.

[00816] Step 1. Selection of serum-free media purveyor. preREP and postREP were set up to mimic 2A process in G-Rex 24 well plate. PreREP were initiated by culturing each

10 fragment/well of G-Rex 24 well plate in triplicates or quatraplicates per conditions. REP

were initiated on Day 11 by culturing  $4 \times 10^5$  TIL/well of G-Rex 24 well, split on Day 16, harvest on Day 22. CTS OpTimizer, X-Vivo 20, and Prime T-CDM were used as potential serum-free media alternatives for use in the PreREP and REP. CTS Immune SR Serum replacement (Life Technologies) or Platelet lysate serum (SDBB) were added at 3% to SFM.

5 Each conditions were planned to test with at least 3 tumors in both preREP and postREP to mimic 2A process.

[00817] Step 2. Identified candidates were further tested on mini-scale 2A processes per protocol (TP-17-007). Briefly, preREP were initiated by culturing 2 fragments/G-Rex 5M flask in triplicates per condition. REP were initiated on Day 11 using  $2 \times 10^6$ /G-Rex 5M  
10 flask, split on Day 16, harvest on Day 22.

[00818] **Note:** Some tumors were processed and setup to measure multiple parameters in one experiment

#### OBSERVATIONS

[00819] Observed equivalent or statistically better results in cell growth when comparing a  
15 serum-free media to the standard used in the 2A process

[00820] Observed similar phenotype, IFN- $\gamma$  production, and metabolite analysis from the TIL grown in serum-free media when compared to the TIL grown in the standard media used in the 2A process.

#### RESULTS

20 **Testing the efficacy of serum free media on pre and post REP TIL expansion.**

[00821] **CTS Optimizer + SR (Serum Replacement) showed enhanced preREP TIL expansion and comparable REP TIL expansion.** CTS OpTimizer, X-Vivo 20, and Prime T-CDM were added with or without 3% CTS Immune CTS SR, were tested against standard  
25 condition. In M1079 and L4026, CTS OpTimizer + CSR condition showed significantly enhanced preREP TIL expansion ( $p < 0.05$ ) when compared with standard conditions (CM1, CM2, CM4) (Figure 62A). Conversely, CTS Optimizer without CSR did not help preREP TIL expansion (Appendix -1,2,3). CTS Optimizer + CSR showed comparable TIL expansion in PostREP in the two tumour of 3 tested (Figure-2B). A large amount of variation occurred  
30 in pre and post REP with the X-Vivo 20 and Prime T-CDM conditions, while CTS Optimizer

was relatively consistent between quadruplicates. In addition, SFM added platelet lysate did not enhance preREP and postREP TIL expansion when compared to standards (Figure 62A). This findings suggesting that serum replacement is certainly needed to provide a comparable growth to our standard, CTS optimizer +CSR may be a candidate.

5 [00822] Testing candidate condition in the G-Rex 5M mini scale (see Figure 64).

[00823] Phenotypic analysis of Post REP TIL. See Figure 66 and Table 56 below.

**Table 56: CD8 skewing with CTS OpTimizer**

	Average %CD8+	
	Standard	CTS
M1078	11	34
M1079	29.3	43.85
M1080	33.67	54.37
L4020	0.02	0.17
EP11020	28.67	25.07
L4030	0.13	0.09
L4026	9.45	34.06
M1092	5.75	52.47
T6030	66	52.6

10 [00824] Interferon-gamma Comparability

[00825] Interferon-gamma ELISA (Quantikine). Production of IFN- $\gamma$  was measured using Quantikine ELISA kit by R&D systems. CTS+SR produced comparable amounts of IFN- $\gamma$  when compared to our standard condition. See, Figure 67.

**EXAMPLE 22: T-CELL GROWTH FACTOR COCKTAIL IL-2/IL-15/IL-21  
ENHANCES EXPANSION AND EFFECTOR FUNCTION  
OF TUMOR -INFILTRATING T CELLS**

**[00826]** Adoptive T cell therapy with autologous tumor infiltrating lymphocytes (TIL) has demonstrated clinical efficacy in patients with metastatic melanoma and cervical carcinoma. In some studies, better clinical outcomes have positively correlated with the total number of cells infused and/or percentage of CD8+ T cells. Most current production regimens solely utilize IL-2 to promote TIL growth. Enhanced lymphocyte expansion has been reported using IL-15 and IL-21-containing regimens. This study describes the positive effects of adding IL-15 and IL-21 to the second generation IL-2-TIL protocol recently implemented in the clinic.

**Materials and Methods**

**[00827]** The process of generating TIL includes a pre-Rapid Expansion Protocol (pre-REP), in which tumor fragments of 1-3 mm<sup>3</sup> size are placed in media containing IL-2. During the pre-REP, TIL emigrate out of the tumor fragments and expand in response to IL-2 stimulation.

**[00828]** To further stimulate TIL growth, TIL are expanded through a secondary culture period termed the Rapid Expansion Protocol (REP) that includes irradiated PBMC feeders, IL-2 and anti-CD3. In this study, a shortened pre-REP and REP expansion protocol was developed to expand TIL while maintaining the phenotypic and functional attributes of the final TIL product.

**[00829]** This shortened TIL production protocol was used to assess the impact of IL-2 alone versus a combination of IL2/IL-15/IL-21. These two culture regimens were compared for the production of TIL grown from colorectal, melanoma, cervical, triple negative breast, lung and renal tumors. At the completion of the pre-REP, cultured TIL were assessed for expansion, phenotype, function (CD107a+ and IFN $\gamma$ ) and TCR V $\beta$  repertoire.

**[00830]** pre-REP cultures were initiated using the standard IL-2 (600 IU/ml) protocol, or with IL-15 (180 IU/ml) and IL-21 (IU/ml) in addition to IL-2. Cells were assessed for expansion at the completion of the pre-REP. A culture was classified as having an increase expansion over the IL-2 if the overall growth was enhanced by at least 20%. The melanoma and lung phenotypic and functional studies are presented herein. See, Table 57 below.

**Table 57: Enhancement in expansion during the pre-REP with IL-2/IL-15/IL-21 in multiple indications**

<b>Tumor Histology</b>	<b># of IL-2 versus IL-2/IL-15/IL-21 studies</b>	<b># of studies demonstrating &gt;20% enhancement of growth using IL-2/IL-15/IL-21 (compared to IL-2)</b>
Melanoma	5	1/5(20%)
Lung	8	3/8 (38%)
Colorectal	11	7/11 (63%)
Cervical	1	1/1 (100%)
Pancreatic	2	2/2 (100%)
Glioblastoma	1	1/1 (100%)
Triple Negative Breast	1	1/2 (50%)

[00831] These data demonstrate an increased TIL product yield when TIL were  
 5 cultured with IL-2/IL15/IL-21 as compared to IL-2 alone, in addition to phenotypic and functional differences in lung.

[00832] The effect of the triple cocktail on TIL expansion was indication-specific and benefited most the low yield tumors.

[00833] The CD8+/CD4+ T cell ratio was increased by the treatment in NSCLC TIL  
 10 product.

[00834] T cell activity appeared enhanced by the addition of IL-15 and IL-21 to IL-2, as assessed by CD107a expression levels in both melanoma and NSCLC.

[00835] The data provided here shows that TIL expansion using a shorter, more robust process, such as the 2A process described herein in the application and other examples, can

be adapted to encompassing the IL-2/IL-15/IL-21 cytokine cocktail, thereby providing a means to further promote TIL expansion in particularly in specific indications.

[00836] Ongoing experiments are further evaluating the effects of IL-2/IL-15/IL-21 on TIL function.

5 [00837] Additional experiments will evaluate the effect of the triple cocktail during the REP (first expansion).

[00838] These observations are especially relevant to the optimization and standardization of TIL culture regimens necessary for large-scale manufacture of TIL with the broad applicability and availability required of a main-stream anti-cancer therapy.

10

### **EXAMPLE 23: A CRYOPRESERVED TIL GENERATED WITH AN ABBREVIATED METHOD**

#### **Background**

[00839] This example provides data related to a cryopreserved tumor infiltrating lymphocyte (TIL) product for LN-144, generated with an abbreviated method suitable for high throughput commercial manufacturing exhibits favorable quality attributes for adoptive cell transfer (ACT).

[00840] Existing methods for generating clinical TIL products involve open operator interventions followed by extended incubation periods to generate a therapeutic product. The Generation 1 process takes approximately 6 weeks and yields a fresh product. To bring TIL therapy to all patients that may benefit from its potential, an abbreviated 22 day culture method, Generation 2, suitable for centralized manufacturing with a cryopreserved drug product capable of shipment to distant clinical sites was developed. Generation 2 represents a flexible, robust, closed, and semi-automated cell production process that is amenable to high throughput manufacturing on a commercial scale. Drug products generated by this method have comparable quality attributes to those generated by the Generation 1 process.

#### **Study Objectives:**

[00841] Drug products generated by Generation 1 (a process 1C embodiment) and Generation 2 (a process 2A embodiment) processes were assayed to determine comparability in terms of the following quality attributes:

Dose and fold expansion.

5 T-cell purity and proportions of T-cell subsets.

Phenotypic expression of co-stimulatory molecules on T-cell subsets.

Average relative length of telomere repeats.

Ability to secrete cytokine in response to TCR reactivation.

T-cell receptor diversity.

10 **Overview of TIL Therapy Process:**

[00842] EXTRACTION: Patient's TIL are removed from suppressive tumor microenvironment (via surgical resection of a lesion)

[00843] EXPANSION: TIL expanded exponentially in culture with IL-2 to yield  $10^9$  –  $10^{11}$  TIL, before infusing them into the patient

15 [00844] PREPARATION: Patient receives NMA-LD (non-myeloablative lymphodepletion, cyclophosphamide: 60 mg/kg, IV x 2 doses and fludarabine: 25 mg/m<sup>2</sup> x 5 doses) to eliminate potentially suppressive tumor microenvironment and maximize engraftment and potency of TIL therapy

20 [00845] INFUSION: Patient is infused with their expanded TIL (LN-144) and a short duration of high-dose of IL-2 (600,000 IU/kg for up to 6 doses) to promote activation, proliferation, and anti-tumor cytolytic activity of TIL

Table 58: Summary of Process Improvements in Generation 2 Manufacturing

Process Step	Gen 1	Gen 2	Impact
Fragment Culture	≤21 days, multiple bioreactors, multiple operator interventions	≤11 days, single closed bioreactor, no intervention	Shortens culture, reduces interventions,

			amenable to automation.
TIL selection	IL-2 expanded TIL cryopreserved, tested, selection based on phenotype, thaw, $\leq 30 \times 10^6$ TIL to co-culture	$\leq 200 \times 10^6$ Bulk TIL direct to co-culture	Shorten process by allowing increased seeding of co-culture, reduces steps, eliminates testing
Rapid Expansion	$\leq 36$ Bioreactors, 14 days	$\leq 5$ Bioreactors, 11 days	Reduces operator interventions, closed system, shortens process, amenable to automation.
Harvest/Wash	Manual open volume reduction and harvest. Manual wash and concentration by centrifugation.	Closed semi-automated volume reduction and harvest. Automated wash and concentration.	Reduces operator interventions, automated, maintains closed system.
Formulation	Fresh hypothermic product (2- 8°C)	Cryopreserved product ( $\leq -150^\circ\text{C}$ )	Shipping flexibility, patient scheduling, easier release testing, global trials
Manufacturing Time	38 day process time	22 day process time	Turnaround to patient, clean room throughput, COGs

**Analytical Methods and Instrumentation:**

[00846] **Dose and Viability:** Final formulated products were sampled and assayed for total nucleated cells, total viable cells, and viability determined by acridine orange / DAPI counterstain using the NC-200 automated cell counter.

- 5 [00847] **Flow cytometry:** Formulated drug products were sampled and assayed for identity by FACS. Percent T-cells was determined as the CD45, CD3 double positive population of viable cells. Frozen satellite or sentinel vials for each process were thawed and assayed for extended phenotypic markers including CD3, CD4, CD8, CD27, and CD28.

- [00848] **Average relative length of telomere repeats:** Flow-FISH technology was  
10 used to measure average length of telomere repeat. This assay was completed as described in the DAKO® Telomere PNA Kit/FITC for Flow Cytometry protocol. Briefly,  $2 \times 10^6$  TIL cells were combined with  $2 \times 10^6$  1301 leukemia cells. The DNA was denatured at 82°C for 10 minutes and the PNA-FITC probe was hybridized in the dark overnight at room temperature. Propidium Iodide was used to identify the cells in G0/1 phase.

- 15 [00849] **Immunoassays:** The ability of the drug product to secrete cytokine upon reactivation was measured following co-culture with mAb-coated beads (Life Technologies, anti-CD3, anti-CD28 & anti-CD137). After 24 hrs culture supernatants were harvested frozen, thawed, and assayed by ELISA using Quantikine IFN $\gamma$  ELISA kit (R&D systems) according to manufacturer's instructions.

- 20 [00850] **T-cell receptor diversity:** RNA from final formulated products was isolated and subjected to a multiplex PCR with VDJ specific primers. CDR3 sequences expressed within the TIL product were semi-quantitatively amplified to determine the frequency and prevalence of unique TIL clones. Sequencing was performed on the Illumina MiSeq benchtop sequencer. Values were indexed to yield a score representative of the relative  
25 diversity of T-cell receptors in the product.

**Results and Conclusions:**

[00851] Results are provided in Figures 75 through 81.

[00852] The Generation 2 process produces a TIL product with comparable quality attributes to Generation 1.

[00853] Generation 2 produces similar quantities of highly pure TIL products that are composed similar proportions of T-cell subsets expressing comparable levels of co-stimulatory molecules relative to Gen 1.

5 [00854] Generation 2 TIL display increased diversity of TCR receptors which, when engaged, initiate robust secretion of cytokine.

[00855] The cryopreserved drug product introduces critical logistical efficiencies allowing flexibility in distribution.

10 [00856] Unlike prior processes, the Generation 2 abbreviated 22-day expansion platform presents a scalable and logistically feasible TIL manufacturing platform that allows for the rapid generation of clinical scale doses for patients in urgent need of therapy.

[00857] The Generation 2 TIL manufacturing protocol addresses many of the barriers that have thus far hindered the wider application of TIL therapy.

#### **EXAMPLE 24: EVALUATING A RANGE OF ALLOGENEIC FEEDER CELL:TIL RATIOS FROM 100:1 TO 25:1**

15 [00858] This study tested the proliferation of TIL at 25:1 and 50:1 against the control of 100:1 allogeneic feeder cells to TIL currently utilized in Process 1C.

20 [00859] Studies published by the Surgery Branch at the National Cancer Institute have shown the threshold for optimal activation of TIL in the G-Rex 100 flask at  $5 \times 10^6$  allogeneic feeder cells per  $\text{cm}^2$  at the initiation of the REP<sup>(1)</sup>. This has been verified through mathematical modeling, and, with the same model, predicted that with a feeder layer optimized for cell:cell contact per unit area the proportion of allogeneic feeder cells relative to TIL may be decreased to 25:1 with minimal effect on TIL activation and expansion.

25 [00860] This study established an optimal density of feeder cells per unit area at REP onset, and validated the effective range of allogeneic feeder ratios at REP initiation needed to decrease and normalize the amount of feeder cells used per clinical lot. The study also validated the initiation of the REP with less than  $200 \times 10^6$  TIL co-cultured with a fixed number of feeder cells.

[00861] A. Volume of a T-cell (10  $\mu\text{m}$  diameter):  $V = (4/3) \pi r^3 = 523.6 \mu\text{m}^3$

[00862] B. Column of G-Rex 100 (M) with a 40  $\mu\text{m}$  (4 cells) height:  $V = (4/3) \pi r^3 = 4 \times 10^{12} \mu\text{m}^3$

[00863] C. Number cell required to fill column B:  $4 \times 10^{12} \mu\text{m}^3 / 523.6 \mu\text{m}^3 = 7.6 \times 10^8 \mu\text{m}^3 * 0.64 = 4.86 \times 10^8$

5 [00864] D. Number cells that can be optimally activated in 4D space:  $4.86 \times 10^8 / 24 = 20.25 \times 10^6$

[00865] E. Number of feeders and TIL extrapolated to G-Rex 500: TIL:  $100 \times 10^6$  and Feeder:  $2.5 \times 10^9$

[00866] Equation 1. Approximation of the number of mononuclear cells required to  
10 provide an icosahedral geometry for activation of TIL in a cylinder with a 100  $\text{cm}^2$  base. The calculation derives the experimental result of  $\sim 5 \times 10^8$  for threshold activation of T-cells which closely mirrors NCI experimental data.<sup>(1)</sup> (C) The multiplier (0.64) is the random packing density for equivalent spheres as calculated by Jaeger and Nagel in 1992<sup>(2)</sup>. (D) The divisor 24 is the number of equivalent spheres that could contact a similar object in 4 dimensional  
15 space “the Newton number.”<sup>(3)</sup>.

### References

[00867] <sup>(1)</sup> Jin, Jianjian, et.al., Simplified Method of the Growth of Human Tumor Infiltrating Lymphocytes (TIL) in Gas-Permeable Flasks to Numbers Needed for Patient Treatment. J Immunother. 2012 Apr; 35(3): 283–292.

20 [00868] <sup>(2)</sup> Jaeger HM, Nagel SR. Physics of the granular state. Science. 1992 Mar 20;255(5051):1523-31.

[00869] <sup>(3)</sup> O. R. Musin (2003). "The problem of the twenty-five spheres". Russ. Math. Surv. 58 (4): 794–795.

### EXAMPLE 25: STUDIES OF KEY QUALITY ATTRIBUTES FOR TIL PRODUCT

#### 25 Background

[00870] Adoptive T-cell therapy with autologous tumor infiltrating lymphocytes (TIL) has demonstrated clinical efficacy in patients with metastatic melanoma and other tumors<sup>1-3</sup>.

[00871] Most reports from clinical studies have included exploratory analyses of the infused TIL products with the intention of identifying quality attributes such as sterility, identity, purity, and potency that could relate to product efficacy and/or safety.<sup>4,5</sup>

5 [00872] Here we present the evaluation of three key product parameters from the TIL product that may contribute to a future quality control platform for use in the commercial manufacture of TIL.

#### **Overview of TIL Therapy Process**

[00873] 1. The tumor was excised from the patient and transported to the GMP Manufacturing facility.

10 [00874] 2. Upon arrival the tumor is fragmented and placed in flasks with IL-2 for a pre-Rapid Expansion Protocol (REP).

[00875] 3. pre-REP TIL were further propagated in a REP protocol in the presence of irradiated PBMCs, anti-CD3 antibody (30 ng/mL), and IL-2 (3000 IU/mL).

15 [00876] 4. TIL products were assessed for critical quality attributes including: (1) Identity (2) Purity, and (3) Potency.

[00877] 5. Prior to infusion of expanded TIL (LN-144), patient received a non-myeloablative lymphodepletion regimen consisting of cyclophosphamide and fludarabine. Following infusion of TIL, patients received a short duration (up to 6 doses) of high-dose IL-2 (600,000 IU/kg) to support growth and engraftment of transferred TIL.

#### 20 **Study Objectives**

[00878] Goal: To fully characterize TIL products for identity, purity, and potency, and thereby (a) guide the definition of critical quality attributes and (b) support the establishment of formal release criteria to be implemented in commercial production of TIL products.

25 [00879] Strategy: To develop the following analytical methodologies to support TIL product characterization. In particular, the following methods were performed: phenotypic analysis by flow cytometry for an identity and purity assessment, residual tumor cell detection assay for a measure of purity, and interferon-gamma release assay for assessment of potency.

## Materials & Methods

### Identity and Purity

[00880] Phenotypic characterization: TIL products were stained with anti-CD45, anti-CD3, anti-CD8, anti-CD4, anti-CD45RA, anti CCR7, anti CD62L, anti-CD19, anti-CD16, and anti-CD56 antibodies and analyzed by flow cytometry for the quantification of T and non-T cell subsets.

### Purity

[00881] Residual tumor detection assay: TIL products were stained with anti-MCSP (melanoma-associated chondroitin sulfate proteoglycan) and anti-CD45 antibodies, as well as a Live/Dead fixable Aqua dye, then analyzed by flow cytometry for the detection of melanoma cells. Spiked controls were used to assess accuracy of tumor detection and to establish gating criteria for data analysis.

### Potency

[00882] IFN $\gamma$  release assay: TIL products were re-stimulated with anti-CD3/CD28/CD137 coated beads for 18 to 24 hours after which supernatants were harvested for assessment of IFN $\gamma$  secretion using an ELISA assay.

## Results

[00883] Identity: The majority (>99%) of melanoma TIL product was composed of CD45<sup>+</sup>CD3<sup>+</sup> cells

[00884] Figures 86A-86C provides phenotypic characterization of TIL products using 10-color flow cytometry assay. (A) Percentage of T-cell and non-T-cell subsets was defined by CD45<sup>+</sup>CD3<sup>+</sup> and CD45<sup>-</sup>(non-lymphocyte)/CD45<sup>+</sup>CD3<sup>-</sup> (non-T-cell lymphocyte), respectively. Overall, >99% of the TIL products tested consisted of T-cell (CD45<sup>+</sup>CD3<sup>+</sup>). Shown is an average of TIL products (n=10). (B) Percentage of two T-cell subsets including CD45<sup>+</sup>CD3<sup>+</sup>CD8<sup>+</sup> (blue open circle) and CD45<sup>+</sup>CD3<sup>+</sup>CD4<sup>+</sup> (pink open circle). No statistical difference in percentage of both subsets was observed using student's unpaired T test (P=0.68). (C) Non-T-cell population was characterized for four different subsets including: 1) Non-lymphocyte (CD45<sup>-</sup>), 2) NK cell (CD45<sup>+</sup>CD3<sup>-</sup>CD16<sup>+</sup>/56<sup>+</sup>), 3) B-cell (CD45<sup>+</sup>CD19<sup>+</sup>), and 4) Non-NK/B-cell (CD45<sup>+</sup>CD3<sup>-</sup>CD16<sup>-</sup>CD56<sup>-</sup>CD19<sup>-</sup>).

[00885] Identity: The majority of melanoma TIL product exhibited effector or memory T-cell phenotype, associated with T-cell cytotoxic function.

**[00886]** Figure 87A and 87B show the characterization of T-cell subsets in CD45<sup>+</sup>CD3<sup>+</sup>CD4<sup>+</sup> and CD45<sup>+</sup>CD3<sup>+</sup>CD8<sup>+</sup> cell populations. Naïve, central memory (TCM), effector memory (TEF), and effector memory RA<sup>+</sup>(EMRA) T-cell subsets were defined using CD45RA and CCR7. Figures 87A and 87B show representative T-cell subsets from 10 final TIL products in both CD4<sup>+</sup> (A), and CD8<sup>+</sup> (B) cell populations. Effector memory T-cell subset (blue open circle) were a major population (>93%) in both CD4<sup>+</sup> and CD8<sup>+</sup> subsets of TIL final product. Less than 7% of the TIL products cells were central memory subset (pink open circle). EMRA (gray open circle) and naïve (black open circle) subsets were barely detected in TIL product (<0.02%). p values represent the difference between EM and CM using student's unpaired T test.

**[00887]** Purity: MCSP represents an appropriate melanoma tumor marker for purity assay.

**[00888]** Figures 88A and 88B show the detection of MCSP and EpCAM expression in melanoma tumor cells. Melanoma tumor cell lines (WM35, 526, and 888), patient-derived melanoma cell lines were generated according to the methods described herein (1028, 1032, and 1041), and a colorectal adenoma carcinoma cell line (HT29 as a negative control) were characterized by staining for MCSP (melanoma-associated chondroitin sulfate proteoglycan) and EpCAM (epithelial cell adhesion molecule) markers. (A) Average of 90% of melanoma tumor cells expressed MCSP. (B) EpCAM expression was not detected in melanoma tumor cell lines as compared positive control HT29, an EpCAM<sup>+</sup> tumor cell line.

**[00889]** Purity: Development of a flow cytometry-based assay for detection of residual tumor cells in TIL products.

**[00890]** Figures 89A and 89B illustrate the detection of spiked controls for the determination of tumor detection accuracy. The assay was performed by spiking known amounts of tumor cells into PBMC suspensions (n=10). MCSP<sup>+</sup>526 melanoma tumor cells were diluted at ratios of 1:10, 1:100, and 1:1,000, then mixed with PBMC and stained with anti-MCSP and anti-CD45 antibodies and live/dead dye and analyzed by flow cytometry. (A) Approximately 3000, 300, and 30 cells were detected in the dilution of 1:10, 1:100, and 1:1000, respectively. (B) An average (AV) and standard deviation (SD) of cells acquired in each condition was used to define the upper and lower reference limits.

**[00891]** Purity: Qualification of residual tumor detection assay using spiked controls

[00892] Figures 90A and 90B show the repeatability study of upper and lower limits in spiked controls. Three independent experiments were performed in triplicate to determine the repeatability of spiking assay. (A) The number of MCSP<sup>+</sup> detected tumor cells were consistently within the range of upper and lower reference limits. (B) Linear regression plot demonstrates the correlation between MCSP<sup>+</sup> cells and spiking dilutions ( $R^2=0.99$ ) with the black solid line showing the best fit. The green and gray broken lines represent the 95% prediction limits in standard curve and samples (Exp#1 to 3), respectively.

[00893] Purity: Melanoma tumor cell contaminants were below the limits of assay detection in final TIL product.

10 [00894] Figures 91A and 91B show the detection of residual melanoma tumor in TIL products. TIL products were assessed for residual tumor contamination using the developed assay (n=15). The median number and percentage of detectable MCSP<sup>+</sup> events was 2 and 0.0002%, respectively.

[00895] Potency: IFN $\gamma$  secretion by TIL (consistently > 1000 pg/ml) demonstrated effector function of TIL product.

[00896] Figure 92 shows the potency assessment of TIL products following T-cell activation. IFN $\gamma$  secretion after re-stimulation with anti-CD3/CD28/CD137 in TIL products assessed by ELISA in duplicate (n=5). IFN $\gamma$  secretion by the TIL products was significantly greater than unstimulated controls using Wilcoxon signed rank test ( $P=0.02$ ), and consistently >1000 pg/ml. IFN $\gamma$  secretion >200 pg/ml was considered to be potent. p value <0.05 is considered statistically significant.

### Conclusion

[00897] Key product parameters of identity, purity, and potency of TIL products were evaluated. TIL products manufactured according to the methods described herein consisted of greater than 99% CD45<sup>+</sup>CD3<sup>+</sup> T cells. The majority of CD4<sup>+</sup> and CD8<sup>+</sup> TIL subsets exhibited an effector-memory phenotype, associated with T-cell cytotoxic function. A flow cytometry-based assay to detect contaminant melanoma tumor cells in final TIL product was successfully developed and qualified. Applying this assay, contaminant melanoma tumor cells in final TIL product were shown to be below the limits of assay detection. IFN $\gamma$  secretion by final TIL product following anti-CD3/CD28/CD137 re-stimulation may serve as a potency assay for commercially manufactured TIL. These data provide the foundation of a

quality control platform that will support further development of critical quality attributes for commercial production of TIL products.

**EXAMPLE 26: A CRYOPRESERVED TIL PRODUCT GENERATED WITH AN  
5 ABBREVIATED METHOD SUITABLE FOR HIGH THROUGHPUT  
COMMERCIAL MANUFACTURING EXHIBITS FAVORABLE QUALITY  
ATTRIBUTES FOR ADOPTIVE CELL TRANSFER**

**Background**

[00898] Classical methods of generating tumor infiltrating lymphocytes (TIL) for  
10 adoptive cell transfer (ACT) involve multiple *ex vivo* incubation steps to yield a fresh (non-  
cryopreserved) infusion product.

[00899] The first generation (Gen 1) process produced a dose of fresh TIL in  
approximately 6 weeks. A second generation (Gen 2) TIL manufacturing process which  
abbreviates the *ex vivo* culture duration to 22 days was developed (Figure 93).

15 [00900] The Gen 2 process is suitable for centralized manufacturing and yields a  
cryopreserved TIL infusion product that brings convenience in scheduling, logistics, and  
delivery to the clinical sites. The cryopreserved TIL infusion product for LN-144 produced  
by the Gen 2 process has comparable quality attributes to the non-cryopreserved TIL infusion  
product for TILs generated by the Gen 1 method. The Gen 2 TIL manufacturing method  
20 represents a flexible, robust, closed, and semi-automated cell production process that is  
amenable to high throughput TIL manufacturing on a commercial scale.

**Study Objective**

[00901] TIL infusion products generated by Gen 1 and Gen 2 manufacturing processes  
were assessed to determine comparability in terms of the following quality attributes: (1)  
25 Cell count (dose), viability, growth rate of REP phase, (2) T-cell purity and phenotypic  
expression of co-stimulatory molecules on T-cell subsets, (3) Average relative length of  
telomere repeats, (4) Ability to secrete IFN $\gamma$  in response to CD3, CD28, CD137 engagement,  
and (5) Diversity of T-cell receptors present in the final infusion product (Figure 94).

### Analytical Methods & Instrumentation

[00902] Cell Count and Viability: Final formulated infusion products were sampled and assayed for total nucleated cells, total viable cells, and viability determined by acridine orange/DAPI counterstain using the NC-200 automated cell counter. Process Development  
5 lots were assayed on the Nexcellom Cellometer K2 Cell Viability Counter using acridine orange/propidium iodine dual florescent staining.

[00903] Phenotypic markers : Formulated infusion products were sampled and assayed for identity by immunofluorescent staining. Percent T-cells was determined as the CD45+,CD3+ (double positive) population of viable cells. Frozen satellite or sentinel vials  
10 for each process were thawed and assayed for extended phenotypic markers including CD3, CD4, CD8, CD27, and CD28. Fresh infusion products were acquired on the BD FACS Canto II, and extended phenotypic markers on thawed infusion products were acquired on the Bio-Rad ZE5 Cell Analyzer.

[00904] Average relative length of telomere repeats: Flow-FISH technology was used  
15 to measure average length of telomere repeat. This assay was completed as described in the DAKO® Telomere PNA Kit/FITC for Flow Cytometry protocol. Briefly,  $2.0 \times 10^6$  TIL cells were combined with  $2.0 \times 10^6$  human cell line (1301) leukemia T-cells. The DNA was denatured at  $82^\circ\text{C}$  for 10 minutes and the PNA-FITC probe was hybridized in the dark overnight at room temperature. Propidium Iodide was used to identify the cells in G0/1  
20 phase.

[00905] Immune function: The ability of the infusion product to secrete  $\text{IFN}\gamma$  upon reactivation was measured following co-culture with antibody coated beads (Life Technologies, anti-CD3, anti-CD28 & anti-CD137). After 24 hours culture supernatants were harvested, frozen, thawed, and assayed by ELISA using the Quantikine  $\text{IFN}\gamma$  ELISA kit  
25 (R&D systems) according to manufacturer's instructions.

[00906] T-cell receptor diversity: RNA from infusion products was isolated and subjected to a multiplex PCR with VDJ specific primers. CDR3 sequences expressed within the TIL product were semi-quantitatively amplified and deep sequenced to determine the frequency and prevalence of unique TIL clones. Sequencing was performed on the Illumina  
30 MiSeq benchtop sequencer. Values were indexed to yield a score representative of the relative diversity of T-cell receptors in the product.

## Results

[00907] On Day 22 the volume reduced cell product was pooled and sampled to determine culture performance prior to wash and formulation. Figures 95A-95C shows total viable cells, growth rate, and viability. (A) Samples were analyzed on the NC-200 automated cell counter as previously described. Total viable cell density is determined by the grand mean of duplicate counts from 4 independent samples. The Gen 2 process yielded a TIL product of similar dose to Gen 1 (Gen 1 mean =  $4.10 \times 10^{10} \pm 2.8 \times 10^{10}$ , Gen 2 mean =  $4.12 \times 10^{10} \pm 2.5 \times 10^{10}$ ). (B) The growth rate was calculated for the REP phase as . (C) Cell viability was assessed from 9 process development lots using the Cellometer K2 as previously described. No significant decrease in cell viability was observed following a single freeze-thaw cycle of the formulated product. Average reduction in viability upon thaw and sampling was 2.19%.

[00908] Figures 96A-96C show that Gen 2 products are highly pure T-cell cultures which express costimulatory molecules at levels comparable to Gen 1. (Figure 96A) Fresh formulated drug products were assayed for identity by flow cytometry for release. Gen 1 and Gen 2 processes produce high purity T-cell cultures as defined by CD45+, CD3+ (double positive) phenotype. (Figures 96B and 96C) Cryopreserved satellite vials of formulated drug product were thawed and assayed for extended phenotype by flow cytometry as previously described. Gen 1 and Gen 2 products expressed similar levels of costimulatory molecules CD27 and CD28 on T-cell subsets. Costimulatory molecules such as CD27 and CD28 may be required to supply secondary and tertiary signaling necessary for effector cell proliferation upon T-cell receptor engagement. P-value was calculated using Mann-Whitney 't' test.

[00909] Figure 97 shows that Gen 2 products trend toward longer relative telomere lengths. Flow-FISH technology was used to measure the average length of the telomere repeat as previously described. The RTL value indicated that the average telomere fluorescence per chromosome/genome in Gen 1 was  $7.5 \% \pm 2.1\%$ , and Gen 2 was  $8.4\% \pm 1.8\%$  of the telomere fluorescence per chromosome/genome in the control cells line (1301 Leukemia cell line). Data indicate Gen 2 products on average have comparable telomere lengths to Gen 1 products. Telomere length is a surrogate measure of the length of *ex vivo* cell culture.

[00910] Figure 98 shows that Gen 2 drug products secrete IFN $\gamma$  in response to CD3, CD28, and CD137 engagement. Cryopreserved drug products were thawed and incubated

with antibody-coated beaded as previously described. Data is expressed as the amount of IFN $\gamma$  produced by  $5 \times 10^5$  viable cells in 24hrs. Gen 2 drug products exhibited an increased ability to produce IFN $\gamma$  upon reactivation relative to Gen 1 drug products. The ability of the drug product to be reactivated and secrete cytokine is a surrogate measure of in-vivo function upon TCR binding to cognate antigen in the context of HLA.

[00911] Figures 99A and 99B shows that Gen 2 drug products have an increased diversity of unique T-cell receptors. T-cell receptor diversity was assessed as follows. RNA from  $10 \times 10^6$  TIL from Gen 1 and Gen 2 infusion products was assayed to determine the total number and frequency of unique CDR3 sequences present in each product. (Figure 99A) Unique CDR3 sequences were indexed relative to frequency in each product to yield a score representative of the overall diversity of T-cell receptors in the product. (Figure 99B) The average total number of unique CDR3 sequences present in each infusion product. TIL products from both processes were composed of polyclonal populations of T-cells with different antigen specificities and avidities. The breadth of the total T-cell repertoire may be indicative of the number of actionable epitopes presented on tumor cells.

### Conclusions

[00912] The Gen 2 manufacturing process produced a TIL infusion product (LN-144) with comparable quality attributes to Gen 1. Gen 2 produced similar doses of highly pure TIL. T-cell subsets were in similar proportions and expressed costimulatory molecules at comparable levels of relative to Gen 1. Gen 2 TIL trended toward longer relative telomere length commensurate with reduced *ex vivo* culture period. Gen 2 TIL displayed an increased diversity of TCR receptors which, when engaged, initiated robust secretion of IFN- $\gamma$ , a measure of cytolytic effector function. Thus, the Gen 2 abbreviated 22-day closed expansion process with cryopreserved infusion product presents a scalable and logistically feasible TIL manufacturing platform that allows for the rapid generation of clinical scale doses for cancer patients in immediate need of a novel therapy option.

### References

[00913] <sup>1</sup> Dudley, M. E. et al. Adoptive cell transfer therapy following non-myeloablative but lymphodepleting chemotherapy for the treatment of patients with refractory metastatic melanoma. *J Clin Oncol* 23, 2346-2357, doi:10.1200/JCO.2005.00.240 (2005).

[00914] <sup>2</sup> Chandran, S. S. et al. Treatment of metastatic uveal melanoma with adoptive transfer of tumour-infiltrating lymphocytes: a single-centre, two-stage, single-arm, phase 2 study. *Lancet Oncol*, doi:10.1016/S1470-2045(17)30251-6 (2017).

5 [00915] <sup>3</sup> Stevanovic, S. et al. Complete regression of metastatic cervical cancer after treatment with human papillomavirus-targeted tumor-infiltrating T cells. *J Clin Oncol* 33, doi:10.1200/jco.2014.58.9093 (2015).

[00916] <sup>4</sup> FDA Reviewers and Sponsors: Content and Review of Chemistry, Manufacturing, and Control (CMC) Information for Human Gene Therapy Investigational New Drug Applications (INDs), 21 CFR 610.3(r), 2008.

10 [00917] <sup>5</sup> Richards JO, Treisman J, Garlie N, Hanson JP, Oaks MK. Flow cytometry assessment of residual melanoma cells in tumor-infiltrating lymphocyte cultures. *Cytometry A* 2012; 81:374-81.

15 **EXAMPLE 27: THE T-CELL GROWTH FACTOR COCKTAIL IL-2/IL-15/IL-21 ENHANCED EXPANSION AND EFFECTOR FUNCTION OF TUMOR-INFILTRATING T CELLS IN A NOVEL PROCESS DESCRIBED HEREIN**

**Background**

[00918] Adoptive T cell therapy with autologous TILs has demonstrated clinical efficacy in patients with metastatic melanoma and cervical carcinoma. In some studies, better clinical outcomes have positively correlated with the total number of cells infused and/or percentage of CD8<sup>+</sup> T cells. Most current production regimens solely utilize IL-2 to promote TIL growth. Enhanced lymphocyte expansion has been reported using IL-15 and IL-21-containing regimens. This study describes the positive effects and synergies of adding IL-15 and IL-21 to embodiments of process 2A and Generation 2 TIL manufacturing processes.

25 **Generation of TIL using a novel process described herein**

[00919] The tumor is excised from the patient and transported to the GMP manufacturing facility or a laboratory for research purposes. Upon arrival the tumor was fragmented, and placed into flasks with IL-2 for pre-Rapid Expansion Protocol (pre-REP) for 11 days. For the triple cocktail studies, IL-2, IL-15, and IL-21 (IL-2/IL-15/IL-21) was added

at the initiation of the pre-REP. For the Rapid Expansion Protocol (REP), TIL were cultured with feeders and anti-CD3 antibody for an additional 11 days (Figure 100).

### Materials and Methods

5 [00920] The process of generating TIL included a pre-Rapid Expansion Protocol (pre-REP), in which tumor fragments of 1-3 mm<sup>3</sup> size were placed in media containing IL-2. During the pre-REP, TIL emigrated out of the tumor fragments and expand in response to IL-2 stimulation.

10 [00921] To further stimulate TIL growth, TIL were expanded through a secondary culture period termed the Rapid Expansion Protocol (REP) that included irradiated PBMC feeders, IL-2 and anti-CD3 antibody. A shortened pre-REP and REP expansion protocol was developed to expand TIL while maintaining the phenotypic and functional attributes of the final TIL product. This shortened TIL-generation protocol was used to assess the impact of IL-2 alone versus a combination of IL2/IL-15/IL-21 added to the pre-REP step. These two culture regimens were compared for the generation of TIL grown from colorectal, melanoma, 15 cervical, triple negative breast, lung and renal tumors. At the completion of the pre-REP, cultured TIL were assessed for expansion, phenotype, function (CD107a<sup>+</sup> and IFN $\gamma$ ) and TCR V $\beta$  repertoire.

20 [00922] The study shows enhancement in expansion during the pre-REP with IL-2/IL-15/IL-21 in multiple tumor histologies. Pre-REP cultures were initiated using the standard IL-2 (6000 IU/mL) protocol, or with IL-15 (180 IU/mL) and IL-21 (1 IU/mL) in addition to IL-2 (Figure 101). Cells were assessed for expansion at the completion of the pre-REP. A culture was classified as having increased expansion over the IL-2 if the overall growth was enhanced by at least 20%. Melanoma and lung phenotypic and functional studies are discussed further in the following paragraphs (bolded text in Figure 101).

25 [00923] IL-2/IL-15/IL-21 enhanced the percentage of CD8<sup>+</sup> cells in lung carcinoma, but not in melanoma. In Figures 102A and 102B, TIL derived from (A) melanoma (n=4), and (B) lung (n=7) were assessed phenotypically for CD4<sup>+</sup> and CD8<sup>+</sup> cells using flow cytometry post pre-REP. p value represents the difference between the IL-2 and IL-12/IL-15/IL-21 conditions using the student's unpaired t-test.

30 [00924] Expression of CD27 was slightly enhanced in CD8<sup>+</sup> cells in cultures treated with IL-2/IL-15/IL-21. In Figures 103A and 103B, TIL derived from (A) melanoma (n=4),

and (B) lung (n=7) were assessed phenotypically for CD27+ and CD28+ in the CD4+ and CD8+ cells using flow cytometry post pre-REP. Expression of CD27, a cellular marker associated with a younger phenotype that has correlated with outcomes to adoptive T cell therapy, was slightly enhanced in CD8+ TIL derived from culture with IL-2/IL-15/IL-21 vs IL-2 alone.

5 [00925] T cell subsets were unaltered with the addition of IL-15/IL-21. In Figures 104A and 104B, TIL were assessed phenotypically for effector/memory subsets (CD45RA and CCR7) in the CD8+ and CD4+ (data not shown) cells from (A) melanoma (n=4), and (B) lung (n=8) via flow cytometry post pre-REP. TEM=effector memory (CD45RA-, CCR7-), TCM=central memory (CD45RA+, CCR7+), TSCM= stem cell memory (CD45RA+, CCR7+), TEMRA=effector T cells (CD45RA+CCR7-).

15 [00926] The functional capacity of TIL was differentially enhanced with IL-2/IL-15/IL-21. In Figures 105A and 105B, TIL derived from (A) melanoma (n=4) and (B) lung (n=5) were assessed for CD107a+ expression in response to PMA stimulation for 4 hours in the CD4+ and CD8+ cells, by flow cytometry. (C) pre-REP TIL derived from melanoma and lung were stimulated for 24 hours with soluble anti-CD3 antibody and the supernatants assessed for IFN $\gamma$  by ELISA.

20 [00927] The relative frequency of the TCR $\nu\beta$  repertoire was altered in response to IL-2/IL-15/IL-21 in lung, but not in melanoma. In Figures 106A and 106B, the TCR $\nu\beta$  repertoire (24 specificities) were assessed in the TIL derived from a (A) melanoma and (B) lung tumor using the Beckman Coulter kit for flow cytometry.

### Summary

25 [00928] This work demonstrates the ability of the IL-2/IL-15/IL-21 cocktail to enhance TIL numbers compared to IL-2 alone (>20%) in the Generation 2 process, in addition to impacting phenotypic and functional characteristics.

30 [00929] The effect of the triple cocktail on TIL expansion was histology dependent. The CD8+/CD4+ T cell ratio was increased with the addition of IL-2/IL-15/IL-21 in lung tumors. Addition of IL-15 and IL-21 enhanced CD107a expression and IFN $\gamma$  production in TIL derived from lung tumors. The addition of IL-2/IL-15/IL-21 altered the TCR $\nu\beta$  repertoire in the lung. The Generation 2 TIL expansion process was used to encompass the IL-2/IL-15/IL-21 cytokine cocktail, thereby providing a means to further promote TIL

expansion in specific tumor histologies, such as lung and colorectal tumors. These observations are especially relevant to the optimization and standardization of TIL culture regimens necessary for large-scale manufacture of TIL with the broad applicability and availability required of a main-stream anti-cancer therapy.

5 **EXAMPLE 28: NOVEL CRYOPRESERVED TUMOR INFILTRATING  
LYMPHOCYTES (LN-144) ADMINISTERED TO PATIENTS WITH METASTATIC  
MELANOMA DEMONSTRATED EFFICACY AND TOLERABILITY IN A  
MULTICENTER PHASE 2 CLINICAL TRIAL**

**Background**

10 [00930] The safety and efficacy of adoptive cell therapy (ACT) utilizing tumor  
infiltrating lymphocytes (TIL) has been studied in hundreds of patients with metastatic  
melanoma, and has demonstrated meaningful and durable objective response rates (ORR).<sup>1</sup>  
In an ongoing Phase 2 trial, C-144-01 utilizing centralized GMP manufacturing of TIL, both  
non-cryopreserved Generation 1 (Gen 1) and cryopreserved Generation 2 (Gen 2) TIL  
15 manufacturing processes were assessed.

[00931] Gen 1 is approximately 5-6 weeks in duration of manufacturing (administered  
in Cohort 1 of C-144-01 study), while Gen 2 is 22 days in duration of manufacturing (process  
2A, administered in Cohort 2 of C-144-01 study). Preliminary data from Cohort 1 patients  
infused with the Gen 1 LN-144 manufactured product, was encouraging in treating post-PD-1  
20 metastatic melanoma patients as the TIL therapy produced responses.<sup>2</sup> Benefits of Gen 2  
included: (A) reduction in the time patients and physicians wait to infuse TIL to patient; (B)  
cryopreservation permits flexibility in scheduling, distribution, and delivery; and (C)  
reduction of manufacturing costs. Preliminary data from Cohort 2 is presented herein.  
Figure 107 shows an embodiment of the Gen 2 cryopreserved LN-144 manufacturing process  
25 (process 2A).

**Study Design: C-144-01 Phase 2 Trial in Metastatic Melanoma**

[00932] Phase 2, Multicenter, 3-Cohort Study to Assess the Efficacy and Safety of  
Autologous Tumor Infiltrating Lymphocytes (LN-144) for Treatment of Patients with  
Metastatic Melanoma.

**[00933]** Key Inclusion Criteria: (1) Measurable metastatic melanoma and  $\geq 1$  lesion resectable for TIL generation; (2) Progression on at least one prior line of systemic therapy; (3) Age  $\geq 18$ ; and (4) ECOG PS 0-1.

**[00934]** Treatment Cohorts: (1) Non-Cryopreserved LN-144 product; (2) Cryopreserved LN-144 product; and (3) Retreatment with LN-144 for patients without response or who progress after initial response. Figure 108 shows the study design.

**[00935]** Endpoints: (1) Primary: Efficacy defined as ORR and (2) Secondary: Safety and Efficacy.

### Methods

10 **[00936]** Cohort 2 Safety Set: 13 patients who underwent resection for the purpose of TIL generation and received any component of the study treatment.

**[00937]** Cohort 2 Efficacy Set: 9 patients who received the NMA-LD preconditioning, LN-144 infusion and at least one dose of IL-2, and had at least one efficacy assessment. 4 patients did not have an efficacy assessment at the time of the data cut.

15 **[00938]** Biomarker data has been shown for all available data read by the date of the data cut.

### Results

**[00939]** Figure 109 provides a table illustrating the Comparison Patient Characteristics from Cohort 1 (ASCO 2017) vs Cohort 2. Cohort 2 has: 4 median prior therapies; all patients have received prior anti-PD-1 and anti-CTLA-4; and had higher tumor burden reflected by greater sum of diameters (SOD) for target lesions and higher mean LDH at Baseline. Figure 110 provides a table showing treatment emergent adverse events ( $\geq 30\%$ ).

25 **[00940]** For Cohort 2 (cryopreserved LN-144), the infusion product and TIL therapy characteristics were (1) mean number of TIL cells infused:  $37 \times 10^9$ , and (2) median number of IL-2 doses administrations was 4.5. Figure 111 shows the efficacy of the infusion product and TIL therapy for Patients #1 to #8.

**[00941]** Figure 112 shows the clinical status of response evaluable patients with stable disease (SD) or a better response. A partial response (PR) for Patient 6 was unconfirmed as the patient did not reach the second efficacy assessment yet. One patient (Patient 9) passed away prior to the first assessment (still considered in the efficacy set).

30

[00942] Of the 9 patients in the efficacy set, one patient (Patient 9) was not evaluable (NE) due to melanoma-related death prior to first tumor assessment not represented on Figure 112. Responses were seen in patients treated with Gen 2. The disease control rate (DCR) was 78%. Time to response was similar to Cohort 1. One patient (Patient 3) with progressive disease (PD) as best response was not included in the swim lane plot.

[00943] Figure 113 shows the percent change in sum of diameters. Patient 9 had no post-LN-144 disease assessment due to melanoma-related death prior to Day 42. Day -14: % change of Sum of Diameters from Screening to Baseline (Day -14). Day -14 to Day 126: % change of SOD from Baseline. Day -14 = Baseline. Day 0 = LN-144 infusion.

[00944] Upon TIL treatment, an increase of HMGB1 was observed (Figure 114). Plasma HMGB1 levels were measured using HMGB1 ELISA kit (Tecan US, Inc). Data shown represents fold change in HMGB1 levels pre (Day -7) and post (Day 4 and Day 14) LN-144 infusion in Cohort 1 and Cohort 2 patients (p values were calculated using two-tailed paired t-test based on log-transformed data). Sample size (bold and italicized) and mean (italicized) values are shown in parentheses for each time point. HMGB1 is secreted by activated immune cells and released by damaged tumor cells. The increased HMGB1 levels observed after treatment with LN-144 are therefore suggestive of an immune-mediated mechanism of anti-tumor activity.

[00945] Plasma IP-10 levels were measured using Luminex assay. Data shown in Figure 115 represents fold change in IP-10 levels pre (Day -7) and post (Day 4 and Day 14) LN-144 infusion in Cohort 1 and Cohort 2 patients (p values were calculated using two-tailed paired t-test based on log-transformed data). Sample size (bold and italicized) and mean (italicized) values are shown in parentheses for each time point. The post-LN-144 infusion increase in IP-10 is being monitored to understand possible correlation with TIL persistence.

[00946] Updated data from Cohort 2 (n = 17 patients) is reported in Figure 116 to Figure 121. In comparison to Cohort 1 and an embodiment of the Gen 1 process, which showed a DCR of 64% and an overall response rate (ORR) of 29% (N = 14), Cohort 2 and an embodiment of the Gen 2 process showed a DCR of 80% and an ORR of 40% (N = 10).

### Conclusions

[00947] Preliminary results from the existing data demonstrate comparable safety between Gen 1 and Gen 2 LN-144 TIL products. Administration of TILs manufactured with

the Gen 2 process (process 2A, as described herein) leads to surprisingly increased clinical responses seen in advanced disease metastatic melanoma patients, all had progressed on anti-PD-1 and anti-CTLA-4 prior therapies. The DCR for cohort 2 was 78%.

5 [00948] Preliminary biomarker data is supportive of the cytolytic mechanism of action proposed for TIL therapy.

[00949] The embodiment of the Gen 2 manufacturing process described herein takes 22 days. This process significantly shortens the duration of time a patient has to wait to receive their TIL, offers flexibility in the timing of dosing the patients, and leads to a reduction of cost of manufacturing, while providing other advantages over prior approaches  
10 that allow for commercialization and registration with health regulatory agencies. Preliminary clinical data in metastatic melanoma using an embodiment of the Gen 2 manufacturing process also indicates a surprising improvement in clinical efficacy of the TILs, as measured by DCR, ORR, and other clinical responses, with a similar time to response and safety profile compared to TILs manufactured using the Gen 1 process. The  
15 unexpectedly improved efficiency of Gen 2 TIL product is also demonstrated by a more than five-fold increase in IFN- $\gamma$  production (Figure 98), which is correlated with improved efficacy in general (Figure 122), significantly improved polyclonality (Figure 99A and Figure 99B), and higher average IP-10 and MCP-1 production (Figure 123 to Figure 126).  
Surprisingly, despite the much shorter process of Gen 2, many other critical characteristics of  
20 the TIL product are similar to those observed using more traditional manufacturing processes, including relative telomere length (Figure 97) and CD27 and CD28 expression (Figure 96B and Figure 96C).

#### References

[00950] <sup>1</sup>Goff, et al. Randomized, Prospective Evaluation Comparing Intensity of  
25 Lymphodepletion Before Adoptive Transfer of Tumor-Infiltrating Lymphocytes for Patients With Metastatic Melanoma. *J Clin Oncol*. 2016 Jul 10;34(20):2389-97.

[00951] <sup>2</sup>Sarnaik A, Kluger H, Chesney J, et al. Efficacy of single administration of tumor-infiltrating lymphocytes (TIL) in heavily pretreated patients with metastatic melanoma following checkpoint therapy. *J Clin Oncol*. 2017; 35 [suppl; abstr 3045].

**EXAMPLE 29: HNSCC AND CERVICAL CARCINOMA PHASE 2 STUDIES**

[00952] Enrollment for the HNSCC (head and neck squamous cell carcinoma; C-145-03) phase 2 study. 13 patients consented to the study, TILs were harvested from 10 patients and ultimately 7 patients were infused with 1 more in progress.

5 [00953] Enrollment in the cervical carcinoma phase 2 study (C-145-04). 8 patients consented to the study, TILs were harvested from 4 patients and ultimately 2 patients were infused and 2 more in process.

[00954] The initial data from the ongoing study is provided in Figure 127. Stable disease (SD) and or progressive response was observed in both HNSCC and cervical cancer  
10 patients treated with the TIL therapy at up to 84 days.

15 [00955] The examples set forth above are provided to give those of ordinary skill in the art a complete disclosure and description of how to make and use the embodiments of the compositions, systems and methods of the invention, and are not intended to limit the scope of what the inventors regard as their invention. Modifications of the above-described modes for carrying out the invention that are obvious to persons of skill in the art are intended to be  
20 within the scope of the following claims. All patents and publications mentioned in the specification are indicative of the levels of skill of those skilled in the art to which the invention pertains.

[00956] All headings and section designations are used for clarity and reference purposes only and are not to be considered limiting in any way. For example, those of skill in  
25 the art will appreciate the usefulness of combining various aspects from different headings and sections as appropriate according to the spirit and scope of the invention described herein.

[00957] All references cited herein are hereby incorporated by reference herein in their entireties and for all purposes to the same extent as if each individual publication or patent or

patent application was specifically and individually indicated to be incorporated by reference in its entirety for all purposes.

[00958] Many modifications and variations of this application can be made without departing from its spirit and scope, as will be apparent to those skilled in the art. The specific  
5 embodiments and examples described herein are offered by way of example only, and the application is to be limited only by the terms of the appended claims, along with the full scope of equivalents to which the claims are entitled.

**Sequences:**

SEQ ID NO:1 is the amino acid sequence of the heavy chain of muromonab.

SEQ ID NO:2 is the amino acid sequence of the light chain of muromonab.

SEQ ID NO:3 is the amino acid sequence of a recombinant human IL-2 protein.

5 SEQ ID NO:4 is the amino acid sequence of aldesleukin.

SEQ ID NO:5 is the amino acid sequence of a recombinant human IL-4 protein.

SEQ ID NO:6 is the amino acid sequence of a recombinant human IL-7 protein.

SEQ ID NO:7 is the amino acid sequence of a recombinant human IL-15 protein.

SEQ ID NO:8 is the amino acid sequence of a recombinant human IL-21 protein.

10 Amino acid sequences of muromonab.

Identifier	Sequence (One-Letter Amino Acid Symbols)		
SEQ ID NO:1 Muromonab heavy chain	QVQLQQSGAE LARPGASVKM SCKASGYTFT RYTMHWVKQR PGQGLEWIGY INPSRGYTNV	60	
	NQKFKDKATL TTDKSSSTAY MQLSSLTSED SAVYYCARYY DDHYCLDYWG QGTTTLTVSSA	120	
	KTTAPSVYPL APVCGGTGGS SVTLGCLVKG YFPEPVTLTW NSGSLSSGVH TFPAVLQSDL	180	
	YTLSSSVTVT SSTWPSQSIT CNVAHPASST KVDKKIEPRP KSCDKTHTCP PCPAPPELLGG	240	
	PSVFLFPPKP KDTLMISRTP EVTCVVVDVS HEDPEVKFNW YVDGVEVHNA KTKPREEQYN	300	
	STYRVVSVLT VLHQDWLNGK EYKCKVSNKA LPAPIEKTIS KAKGQPREPQ VYTLPPSRDE	360	
	LTKNQVSLTC LVKGFYPSDI AVEWESNGQP ENNYKTTTPV LDSDGSFFLY SKLTVDKSRW	420	
	QQGNVFSCSV MHEALHNHYT QKSLSLSPGK	450	
	SEQ ID NO:2 Muromonab light chain	QIVLTQSPAI MSASPGEKVT MTCASASSVS YMNWYQQKSG TSPKRWIYDT SKLASGVPAH	60
	FRGSGSGTSY SLTISGMEAE DAATYYCQQW SSNPFTFGSG TKLEINRADT APTVSIFFPS	120	
SEQLTSGGAS VVCFLNNFYP KDINVKWKID GSERQNGVLN SWTQDQSKDS TYSMSSTLTL	180		
TKDEYERHNS YTCEATHKTS TSPIVKSFNR NEC	213		

## Amino acid sequences of interleukins.

Identifier	Sequence (One-Letter Amino Acid Symbols)	
SEQ ID NO:3 recombinant human IL-2 (rhIL-2)	MAPTSSSTKK TQLQLEHLL DLQILNGIN NYKNPKLTRM LTFKPYMPKK ATELKHLQCL	60
	EELKPLEEV LNLAQSKNFH LRPRDLISNI NVIVLELKGS ETTFMCEYAD ETATIVEFLN	120
	RWITFCQSII STLT	134
SEQ ID NO:4 Aldesleukin	PTSSSTKKTQ LQLEHLLDL QMILNGINNY KNPKLTRMLT FKFYMPKKAT ELKHLQCLEE	60
	ELKPLEEVLN LAQSKNFHLR PRDLISNINV IVLELKGSET TFMCEYADET ATIVEFLNRW	120
	ITFSQSIIST LT	132
SEQ ID NO:5 recombinant human IL-4 (rhIL-4)	MHKCDITLQE IIKTLNSLTE QKTLCTELTV TDIFAASKNT TEKETFCAA TVLRQFYSHH	60
	EKDTRCLGAT AQQFHRHKQL IRFLKRLDRN LWGLAGLNSC PVKEANQSTL ENFLERLKI	120
	MREKYSKCSS	130
SEQ ID NO:6 recombinant human IL-7 (rhIL-7)	MDCDIEGKDG KQYESVLMVS IDQLLDSMKE IGSNCLNNEF NFFKRHICDA NKEGMFLFRA	60
	ARKLRQFLKM NSTGDFDLHL LKVSEGTTL LNCTGQVKGR KPAALGEAQP TKSLEENKSL	120
	KEQKLLNDLC FLKRLQEI KTCWNKILMGT KEH	153
SEQ ID NO:7 recombinant human IL-15 (rhIL-15)	MNWNVISDL KKIEDLIQSM HIDATLYTES DVHPSCKVTM MKCFLELQV ISLES GDASI	60
	HDTVENLIIL ANNSLSSNGN VTESGCKECE ELEKNIKEF LQSFVHIVQM FINITS	115
SEQ ID NO:8 recombinant human IL-21 (rhIL-21)	MQDRHMIRMRL QLIDIVDQLK NYVNDLVPEF LPAPEDVETN CEWSAFSCFQ KAQLKSANTG	60
	NNERIINVSI KKLKRKPPST NAGRRQKHLR TCPSCDSYEK KPPKEFLERF KSLLQKMIHQ	120
	HLSSRTHGSE DS	132

**WHAT IS CLAIMED IS:**

1. Use of tumor infiltrating lymphocytes (TILs) in the manufacture of expanded tumor infiltrating lymphocytes (TILs) for treating a subject with cancer, comprising:
  - (a) obtaining a first population of TILs from a tumor resected from a subject by processing a tumor sample obtained from the subject into multiple tumor fragments;
  - (b) adding the tumor fragments into a closed system;
  - (c) performing a first expansion by culturing the first population of TILs in a cell culture medium comprising IL-2 to produce a second population of TILs, wherein the first expansion is performed in a closed container providing a first gas-permeable surface area, wherein the first expansion is performed for about 3-11 days to obtain the second population of TILs, wherein the second population of TILs is at least 50-fold greater in number than the first population of TILs, and wherein the transition from step (b) to step (c) occurs without opening the system;
  - (d) performing a second expansion by supplementing the cell culture medium of the second population of TILs with additional IL-2, OKT-3, and antigen presenting cells (APCs), to produce a third population of TILs, wherein the second expansion is performed for about 7-11 days to obtain the third population of TILs, wherein the third population of TILs is a therapeutic population of TILs which comprises an increased subpopulation of effector T cells and/or central memory T cells relative to the second population of TILs, wherein the second expansion is performed in a closed container providing a second gas-permeable surface area, and wherein the transition from step (c) to step (d) occurs without opening the system;
  - (e) harvesting the therapeutic population of TILs obtained from step (d), wherein the transition from step (d) to step (e) occurs without opening the system;
  - (f) transferring the harvested TIL population from step (e) to an infusion bag, wherein the transfer from step (e) to (f) occurs without opening the system;
  - (g) cryopreserving the infusion bag comprising the harvested TIL population from step (f) using a cryopreservation process; and
  - (h) wherein a therapeutically effective dosage of the third population of TILs from the infusion bag in step (g) is for administration to the subject.

2. Use of tumor infiltrating lymphocytes (TILs) in the manufacture of expanded tumor infiltrating lymphocytes (TILs) for treating a subject with cancer, comprising:
- (a) obtaining a first population of TILs from a tumor resected from a subject by processing a tumor sample obtained from the subject into multiple tumor fragments;
  - 5 (b) adding the tumor fragments into a closed system;
  - (c) performing a first expansion by culturing the first population of TILs in a cell culture medium comprising IL-2 to produce a second population of TILs, wherein the first expansion is performed in a closed container providing a first gas-permeable surface area, wherein the first expansion is performed for about 3-11 days to obtain the second  
10 population of TILs wherein the second population of TILs is at least 50-fold greater in number than the first population of TILs, and wherein the transition from step (b) to step (c) occurs without opening the system;
  - (d) performing a second expansion by supplementing the cell culture medium of the second population of TILs with additional IL-2, OKT-3, and antigen presenting cells (APCs), to  
15 produce a third population of TILs, wherein the second expansion is performed for about 7-11 days to obtain the third population of TILs, wherein the second expansion is performed in a closed container providing a second gas-permeable surface area, and wherein the transition from step (c) to step (d) occurs without opening the system;
  - (e) harvesting the third population of TILs obtained from step (d), wherein the transition from  
20 step (d) to step (e) occurs without opening the system;
  - (f) transferring the harvested third TIL population from step (e) to an infusion bag, wherein the transfer from step (e) to (f) occurs without opening the system;
  - (g) cryopreserving the infusion bag comprising the harvested TIL population from step (f) using a cryopreservation process; and
  - 25 (h) wherein a therapeutically effective dosage of the third population of TILs from the infusion bag instep (g) is for administration to the subject.
3. The use according to claims 1 or 2, wherein the medium in the first expansion and/or the second expansion is free of human serum.
4. The use according to claims 1 or 2, wherein the therapeutic population of TILs harvested  
30 in step (e) comprises sufficient TILs for administering a therapeutically effective dosage of the TILs in step (h).

5. The use according to claim 4, wherein the number of TILs sufficient for administering a therapeutically effective dosage in step (h) is from about  $1 \times 10^9$  to about  $9 \times 10^{10}$ .
6. The use according to claims 1 or 2, wherein the APCs are peripheral blood mononuclear cells (PBMCs).
- 5 7. The use according to claims 1 or 2, wherein the therapeutic population of TILs harvested in step (e) exhibits an increased subpopulation of CD8+ cells relative to the first and/or second population of TILs.
8. The use according to claim 6, wherein the PBMCs are supplemented at a ratio of about 1:25 TIL:PBMCs.
- 10 9. The use according to claims 1 or 2, wherein prior to administering a therapeutically effective dosage of TIL cells in step (h), a non-myeloablative lymphodepletion regimen has been administered to the subject.
10. The use according to claim 9, where the non-myeloablative lymphodepletion regimen comprises the steps of administration of cyclophosphamide at a dose of  $60 \text{ mg/m}^2/\text{day}$  for two days followed by administration of fludarabine at a dose of  $25 \text{ mg/m}^2/\text{day}$  for five days.
- 15 11. The use according to claims 1 or 2, further comprising the step of treating the subject with a high-dose IL-2 regimen starting on the day after administration of the TIL cells to the subject in step (h).
12. The use according to claim 11, wherein the high-dose IL-2 regimen comprises 600,000 or 20 720,000 IU/kg administered as a 15-minute bolus intravenous infusion every eight hours until tolerance.
13. The use according to claims 1 or 2, wherein the third population of TILs in step (d) provides for increased efficacy, increased interferon-gamma (IFN- $\gamma$ ) production, increased polyclonality, increased average IP-10, and/or increased average MCP-1 when administered to 25 the subject.
14. The use according to claims 1 or 2, wherein the cancer is selected from the group consisting of melanoma (including metastatic melanoma), ovarian cancer, cervical cancer, non-small-cell lung cancer (NSCLC), lung cancer, bladder cancer, breast cancer, cancer caused by human papilloma virus, head and neck cancer (including head and neck squamous cell carcinoma 30 (HNSCC)), renal cancer, and renal cell carcinoma.

15. The use according to claim 14, wherein the cancer is selected from the group consisting of melanoma, metastatic melanoma, HNSCC, cervical cancer, and NSCLC.
16. The use according to claims 1 or 2, wherein the first expansion in step (c) and the second expansion in step (d) are each individually performed within a period of 11 days.
- 5 17. The use according to claims 1 or 2, wherein steps (a) through (f) are performed in about 10 days to about 22 days.
18. Use of tumor infiltrating lymphocytes (TILs) in the manufacture of expanded tumor infiltrating lymphocytes (TILs) for treating a subject with cancer, in combination with an anti-PD-1 antibody, comprising:
- 10 (a) obtaining a first population of TILs from a tumor resected from a subject by processing a tumor sample obtained from the subject into multiple tumor fragments;
- (b) adding the tumor fragments into a closed system;
- (c) performing a first expansion by culturing the first population of TILs in a cell culture medium comprising IL-2 to produce a second population of TILs, wherein the first  
15 expansion is performed in a closed container providing a first gas-permeable surface area, wherein the first expansion is performed for about 3-11 days to obtain the second population of TILs, wherein the second population of TILs is at least 50-fold greater in number than the first population of TILs, and wherein the transition from step (b) to step (c) occurs without opening the system;
- 20 (d) performing a second expansion by supplementing the cell culture medium of the second population of TILs with additional IL-2, OKT-3, and antigen presenting cells (APCs), to produce a third population of TILs, wherein the second expansion is performed for about 7-11 days to obtain the third population of TILs, wherein the third population of TILs is a therapeutic population of TILs which comprises an increased subpopulation of effector T  
25 cells and/or central memory T cells relative to the second population of TILs, wherein the second expansion is performed in a closed container providing a second gas-permeable surface area, and wherein the transition from step (c) to step (d) occurs without opening the system;
- (e) harvesting the therapeutic population of TILs obtained from step (d), wherein the  
30 transition from step (d) to step (e) occurs without opening the system;

- (f) transferring the harvested TIL population from step (e) to an infusion bag, wherein the transfer from step (e) to (f) occurs without opening the system;
- (g) cryopreserving the infusion bag comprising the harvested TIL population from step (f) using a cryopreservation process; and
- 5 (h) wherein a therapeutically effective dosage of the third population of TILs from the infusion bag in step (g) is for administration to the subject in combination with the anti-PD-1 antibody.
19. The use according to claim 18, wherein the anti-PD-1 antibody is nivolumab.
20. The use according to claim 18, wherein the anti-PD-1 antibody is pembrolizumab.
- 10 21. The use according to claim 18, wherein the cancer is selected from the group consisting of melanoma (including metastatic melanoma), ovarian cancer, cervical cancer, non-small-cell lung cancer (NSCLC), lung cancer, bladder cancer, breast cancer, cancer caused by human papilloma virus, head and neck cancer (including head and neck squamous cell carcinoma (HNSCC)), renal cancer, and renal cell carcinoma.
- 15 22. The use according to claim 21, wherein the cancer is bladder cancer.
23. A method for expanding tumor infiltrating lymphocytes (TILs) into a therapeutic population of TILs, the method comprising:
- (a) obtaining a first population of TILs from a tumor resected from a subject by processing a tumor sample obtained from the subject into multiple tumor fragments;
- 20 (b) adding the tumor fragments into a closed system;
- (c) performing a first expansion by culturing the first population of TILs in a cell culture medium comprising IL-2 to produce a second population of TILs, wherein the first expansion is performed in a closed container providing a first gas-permeable surface area, wherein the first expansion is performed for about 3-11 days to obtain the second
- 25 population of TILs, wherein the second population of TILs is at least 50-fold greater in number than the first population of TILs, and wherein the transition from step (b) to step (c) occurs without opening the system;
- (d) performing a second expansion by supplementing the cell culture medium of the second population of TILs with additional IL-2, OKT-3, and antigen presenting cells (APCs), to
- 30 produce a third population of TILs, wherein the second expansion is performed for about 7-11 days to obtain the third population of TILs, wherein the third population of TILs is a

- therapeutic population of TILs which comprises an increased subpopulation of effector T cells and/or central memory T cells relative to the second population of TILs, wherein the second expansion is performed in a closed container providing a second gas-permeable surface area, and wherein the transition from step (c) to step (d) occurs without opening the system;
- 5
- (e) harvesting the therapeutic population of TILs obtained from step (d), wherein the transition from step (d) to step (e) occurs without opening the system;
  - (f) transferring the harvested TIL population from step (e) to an infusion bag, wherein the transfer from step (e) to (f) occurs without opening the system; and
  - 10 (g) cryopreserving the infusion bag comprising the harvested TIL population from step (f) using a cryopreservation process.
24. A method for expanding tumor infiltrating lymphocytes (TILs) into a therapeutic population of TILs, the method comprising:
- 15 (a) obtaining a first population of TILs from a tumor resected from a subject by processing a tumor sample obtained from the subject into multiple tumor fragments;
  - (b) adding the tumor fragments into a closed system;
  - (c) performing a first expansion by culturing the first population of TILs in a cell culture medium comprising IL-2 to produce a second population of TILs, wherein the first expansion is performed in a closed container providing a first gas- permeable surface area, wherein the first expansion is performed for about 3-11 days to obtain the second population of TILs, wherein the second population of TILs is at least 50-fold greater in number than the first population of TILs, and wherein the transition from step (b) to step (c) occurs without opening the system;
  - 20 (d) performing a second expansion by supplementing the cell culture medium of the second population of TILs with additional IL-2, OKT-3, and antigen presenting cells (APCs), to produce a third population of TILs, wherein the second expansion is performed for about 7-11 days to obtain the third population of TILs, wherein the second expansion is performed in a closed container providing a second gas-permeable surface area, and wherein the transition from step (c) to step (d) occurs without opening the system;
  - 25 (e) harvesting the therapeutic population of TILs obtained from step (d), wherein the transition from step (d) to step (e) occurs without opening the system;
  - 30

- (f) transferring the harvested TIL population from step (e) to an infusion bag, wherein the transfer from step (e) to (f) occurs without opening the system; and
- (g) cryopreserving the infusion bag comprising the harvested TIL population from step (f) using a cryopreservation process.
- 5 25. The method according to claims 23 or 24, wherein the medium in the first expansion and/or the second expansion is free of human serum.
26. The method according to claims 23 or 24, wherein the therapeutic population of TILs harvested in step (e) comprises sufficient TILs for use in administering a therapeutically effective dosage to a subject.
- 10 27. The method according to claim 26, wherein the number of TILs sufficient for administering a therapeutically effective dosage is from about  $1 \times 10^9$  to about  $9 \times 10^{10}$ .
28. The method according to claims 23 or 24, wherein the APCs are peripheral blood mononuclear cells (PBMCs).
29. The method according to claim 28, wherein the therapeutic population of TILs harvested  
15 in step (e) exhibits an increased subpopulation of CD8+ cells relative to the first and/or second population of TILs.
30. The method according to claim 28, wherein the PBMCs are supplemented at a ratio of about 1:25 TIL:PBMCs.
31. The method according to claims 23 or 24, wherein the first expansion in step (c) and the  
20 second expansion in step (d) are each individually performed within a period of 11 days.
32. The method according to claims 23 or 24, wherein steps (a) through (f) are performed in about 10 days to about 22 days.
33. The method according to claims 23 or 24, wherein steps (a) through (f) are performed in about 15 days to about 22 days.
- 25 34. The method according to claims 23 or 24, wherein steps (a) through (f) are performed in about 20 days to about 22 days.
35. A cryopreserved tumor infiltrating lymphocyte (TIL) composition comprising a therapeutic population of infiltrating lymphocytes (TILs), wherein the cryopreserved TIL composition is produced by a method comprising:
- 30 (a) obtaining a first population of TILs from a tumor resected from a subject by processing a tumor sample obtained from the subject into multiple tumor fragments;

- (b) adding the tumor fragments into a closed system;
  - (c) performing a first expansion by culturing the first population of TILs in a cell culture medium comprising IL-2 to produce a second population of TILs, wherein the first expansion is performed in a closed container providing a first gas-permeable surface area, wherein the first expansion is performed for about 3-11 days to obtain the second population of TILs, wherein the second population of TILs is at least 50-fold greater in number than the first population of TILs, and wherein the transition from step (b) to step (c) occurs without opening the system;
  - (d) performing a second expansion by supplementing the cell culture medium of the second population of TILs with additional IL-2, OKT-3, and antigen presenting cells (APCs), to produce a third population of TILs, wherein the second expansion is performed for about 7-11 days to obtain the third population of TILs, wherein the third population of TILs is a therapeutic population of TILs which comprises an increased subpopulation of effector T cells and/or central memory T cells relative to the second population of TILs, wherein the second expansion is performed in a closed container providing a second gas-permeable surface area, and wherein the transition from step (c) to step (d) occurs without opening the system;
  - (e) harvesting the therapeutic population of TILs obtained from step (d), wherein the transition from step (d) to step (e) occurs without opening the system;
  - (f) transferring the harvested TIL population from step (e) to an infusion bag, wherein the transfer from step (e) to (f) occurs without opening the system; and
  - (g) cryopreserving the infusion bag comprising the harvested TIL population from step (f) using a cryopreservation process to obtain the cryopreserved TIL composition.
36. A cryopreserved tumor infiltrating lymphocyte (TIL) composition comprising a therapeutic population of infiltrating lymphocytes (TILs), wherein the cryopreserved TIL composition is produced by a method comprising:
- (a) obtaining a first population of TILs from a tumor resected from a subject by processing a tumor sample obtained from the subject into multiple tumor fragments;
  - (b) adding the tumor fragments into a closed system;
  - (c) performing a first expansion by culturing the first population of TILs in a cell culture medium comprising IL-2 to produce a second population of TILs, wherein the first

- expansion is performed in a closed container providing a first gas- permeable surface area, wherein the first expansion is performed for about 3-11 days to obtain the second population of TILs, wherein the second population of TILs is at least 50-fold greater in number than the first population of TILs, and wherein the transition from step (b) to step
- 5 (c) occurs without opening the system;
- (d) performing a second expansion by supplementing the cell culture medium of the second population of TILs with additional IL-2, OKT-3, and antigen presenting cells (APCs), to produce a third population of TILs, wherein the second expansion is performed for about
- 10 7-11 days to obtain the third population of TILs, wherein the second expansion is performed in a closed container providing a second gas- permeable surface area, and wherein the transition from step (c) to step (d) occurs without opening the system;
- (e) harvesting the therapeutic population of TILs obtained from step (d), wherein the transition from step (d) to step (e) occurs without opening the system;
- (f) transferring the harvested TIL population from step (e) to an infusion bag, wherein the
- 15 transfer from step (e) to (f) occurs without opening the system; and
- (g) cryopreserving the infusion bag comprising the harvested TIL population from step (f) using a cryopreservation process to obtain the cryopreserved TIL composition.
37. An expanded tumor infiltrating lymphocyte (TIL) composition comprising:
- 20 i) a therapeutic population of tumor infiltrating lymphocytes (TILs), wherein said therapeutic population comprises expanded TILs, and
- ii) a cryopreservant;
- wherein the therapeutic population of TILs exhibits increased IFN- $\gamma$  secretion by at least one-fold to at least five-fold *in vitro* as compared to a non-expanded population of TILs.
- 25 38. An expanded tumor infiltrating lymphocyte (TIL) composition comprising:
- i) a therapeutic population of tumor infiltrating lymphocytes (TILs), wherein said therapeutic population comprises expanded TILs, and
- ii) a cryopreservant;
- wherein the therapeutic population of TILs is capable of exhibiting IFN- $\gamma$  secretion
- 30 greater than 200 pg/ml, optionally greater than 1000 pg/ml.

39. The expanded TIL composition according to claim 37 or claim 38, wherein the cryopreservant is DMSO.
40. A tumor infiltrating lymphocyte (TIL) pharmaceutical composition comprising:  
i) an expanded population of tumor infiltrating lymphocytes (TILs), and  
5 ii) a pharmaceutically acceptable carrier;  
wherein the expanded population of TILs is capable of exhibiting increased IFN- $\gamma$  secretion by at least one-fold to at least five-fold *in vitro* as compared to a non-expanded population of TILs.
41. A tumor infiltrating lymphocyte (TIL) pharmaceutical composition comprising:  
10 i) an expanded population of tumor infiltrating lymphocytes (TILs), and  
ii) a pharmaceutically acceptable carrier;  
wherein the expanded population of TILs is capable of exhibiting IFN- $\gamma$  secretion greater than 200 pg/ml, optionally greater than 1000 pg/ml.
42. The expanded TIL composition according to claim 40 or claim 41, wherein the  
15 composition further comprises a cryopreservant.
43. The expanded TIL composition according to claim 42, wherein the cryopreservant is DMSO.
44. A population of expanded TILs produced according to the method of any one of claims  
24 to 34, or a cryopreserved tumor infiltrating lymphocyte (TIL) composition comprising a  
20 therapeutic population of infiltrating lymphocytes (TILs) according to claim 35 or claim 36, or  
an expanded tumor infiltrating lymphocyte (TIL) composition according to any one of claims  
37 to 43, for use in a method of treating a subject with cancer.

Process 2A-22 Days Process, 2-3 Days Harvest/Ship

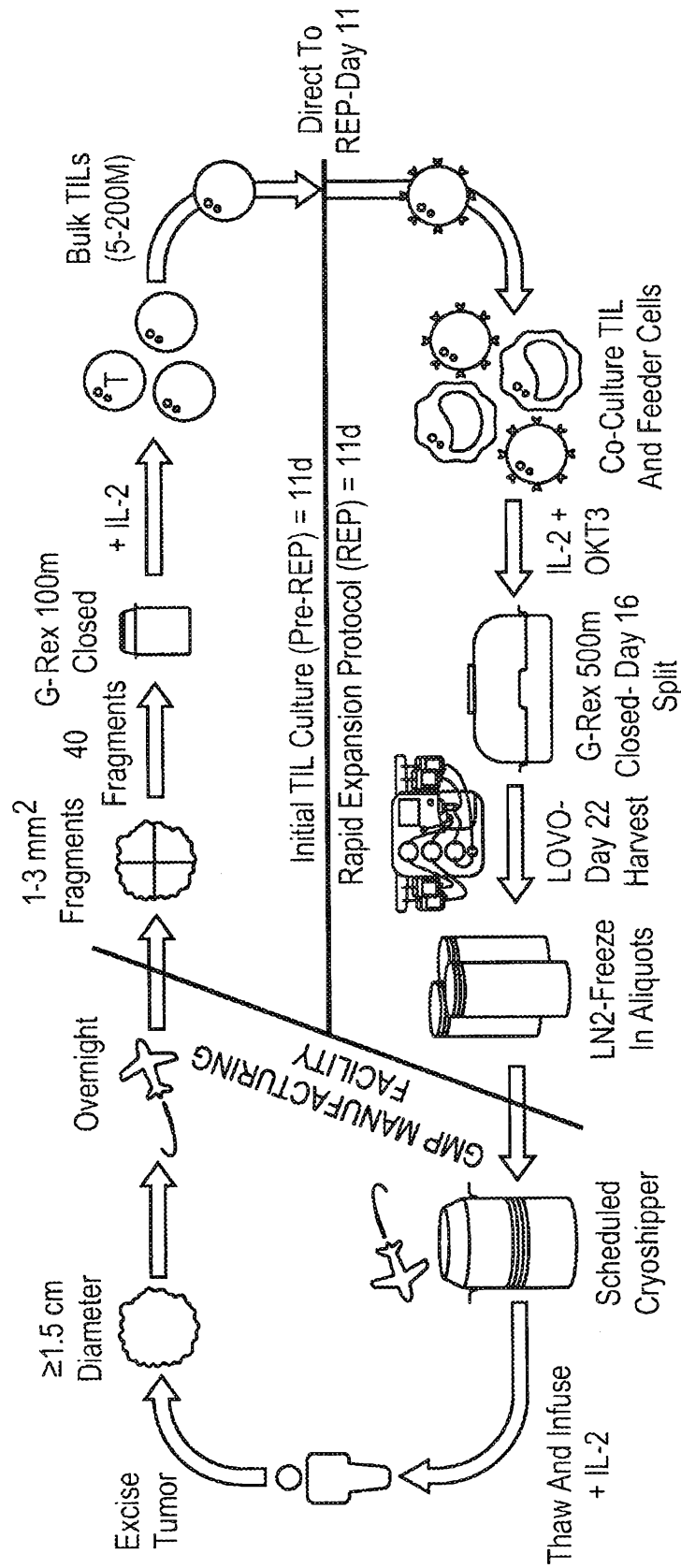

Figure 1

Process Development

Step	Current Process-1C	New Process-2A	Impact
1	4 Fragments/10 G-Rex 10-21 Days	40 Fragments/1-G-Rex 100 CS- (x2?) 11 Days	Increases Tumor Sample/Container, Shortens Culture, Reduces Steps, Amenable To Closed System
2	PreREP Freeze-> Testing -> Thaw- ~Day 27- >40e6TIL	Direct To REP- Day 11- <200e6	Shorten Process, Reduces Steps, Eliminates Testing
3	36 G-Rex 100-~Day 30 >5e6TIL - Split ~Day 36	4-5 G-Rex 500CS-TIL- Split Day 16	Reduces Steps, Closed System, Shorter REP
4	Harvest Day ~43+ Harvesting By Centrifugation	Harvest Day 22 LOVO-Automated Cell Washer	Reduces Steps, Automated, Closed System
5	Fresh Product- Hypothermosol-Single Infusion Bag	Cryopreserved Product-CS10 In LN <sub>2</sub> , Multiple Aliquots	Shipping Flexibility, Patient Scheduling, Easier Release Testing, Global Trials
6	43+ Day Process Time	22 Day Process Time	Turnaround To Patient, Clean Room Throughput, COGs

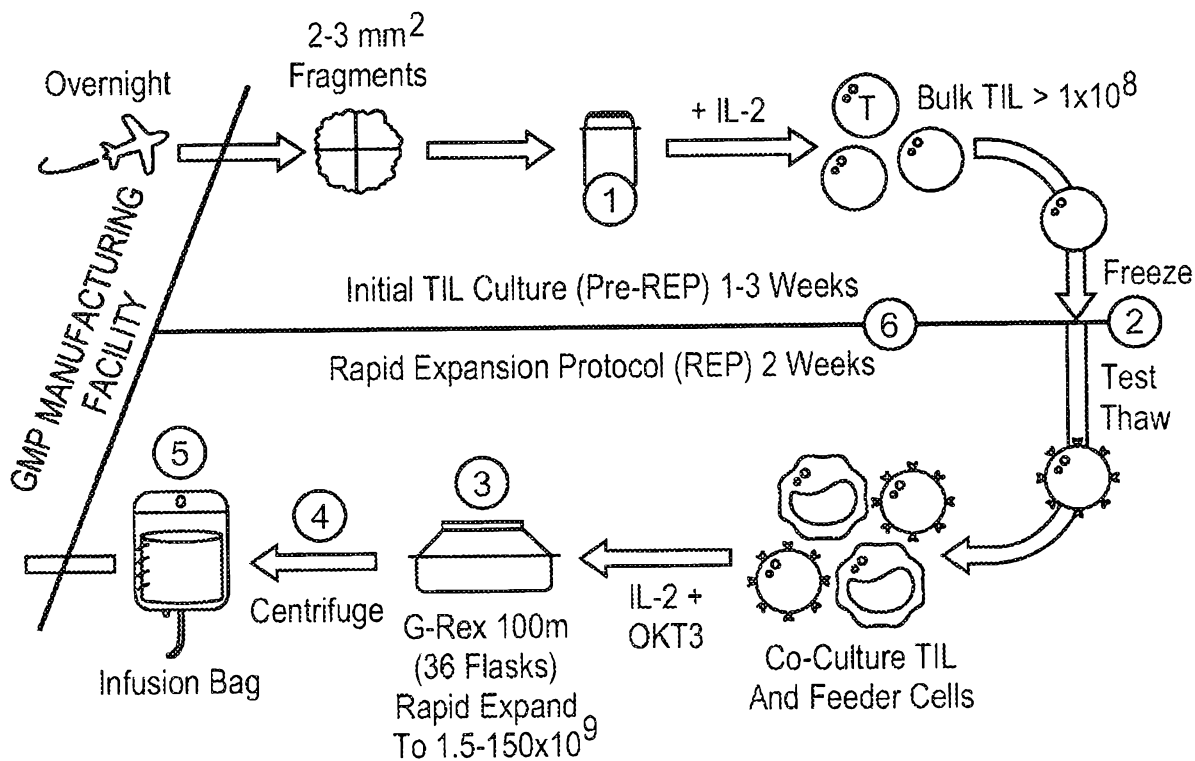

Figure 2

Timeline- Process 1C- Current process

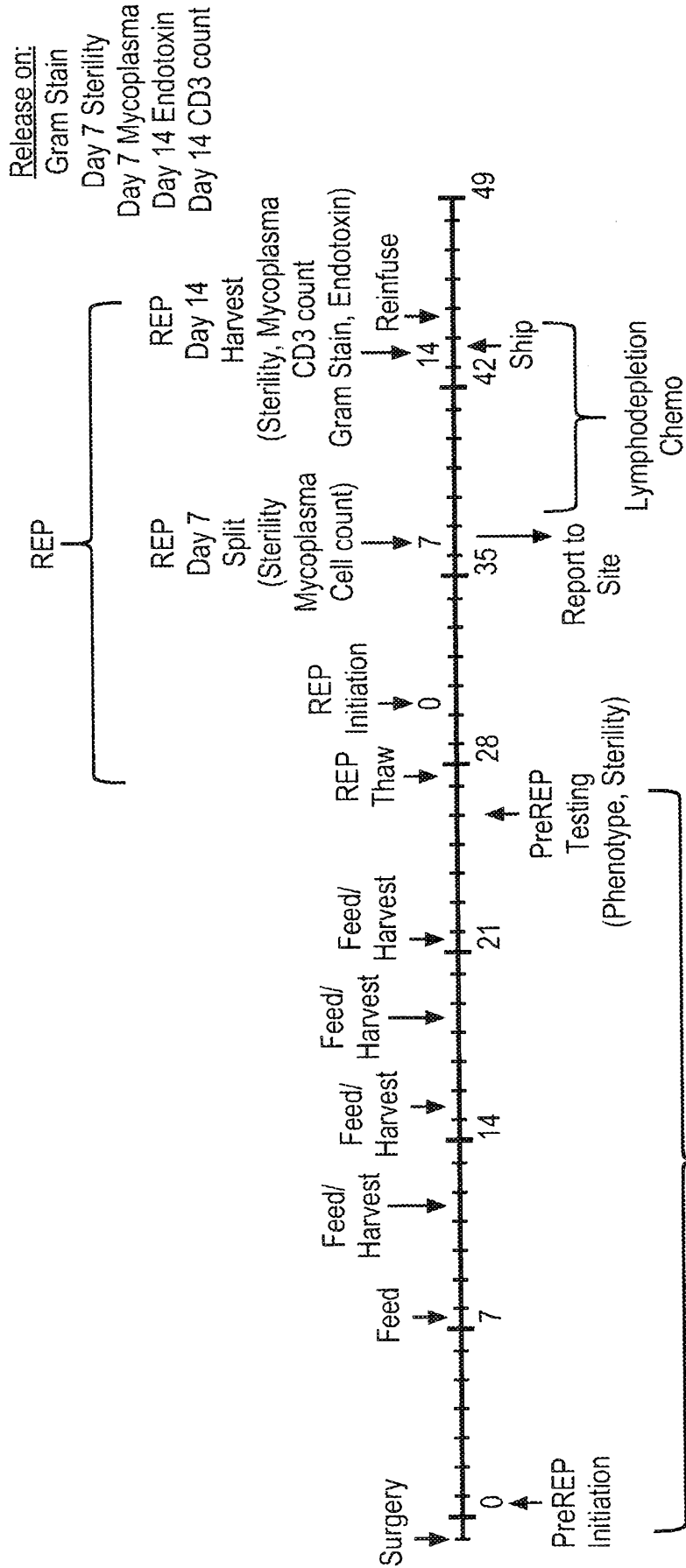

Figure 3

TIL Therapy Timeline- v2A- Day 16 REP >250e6

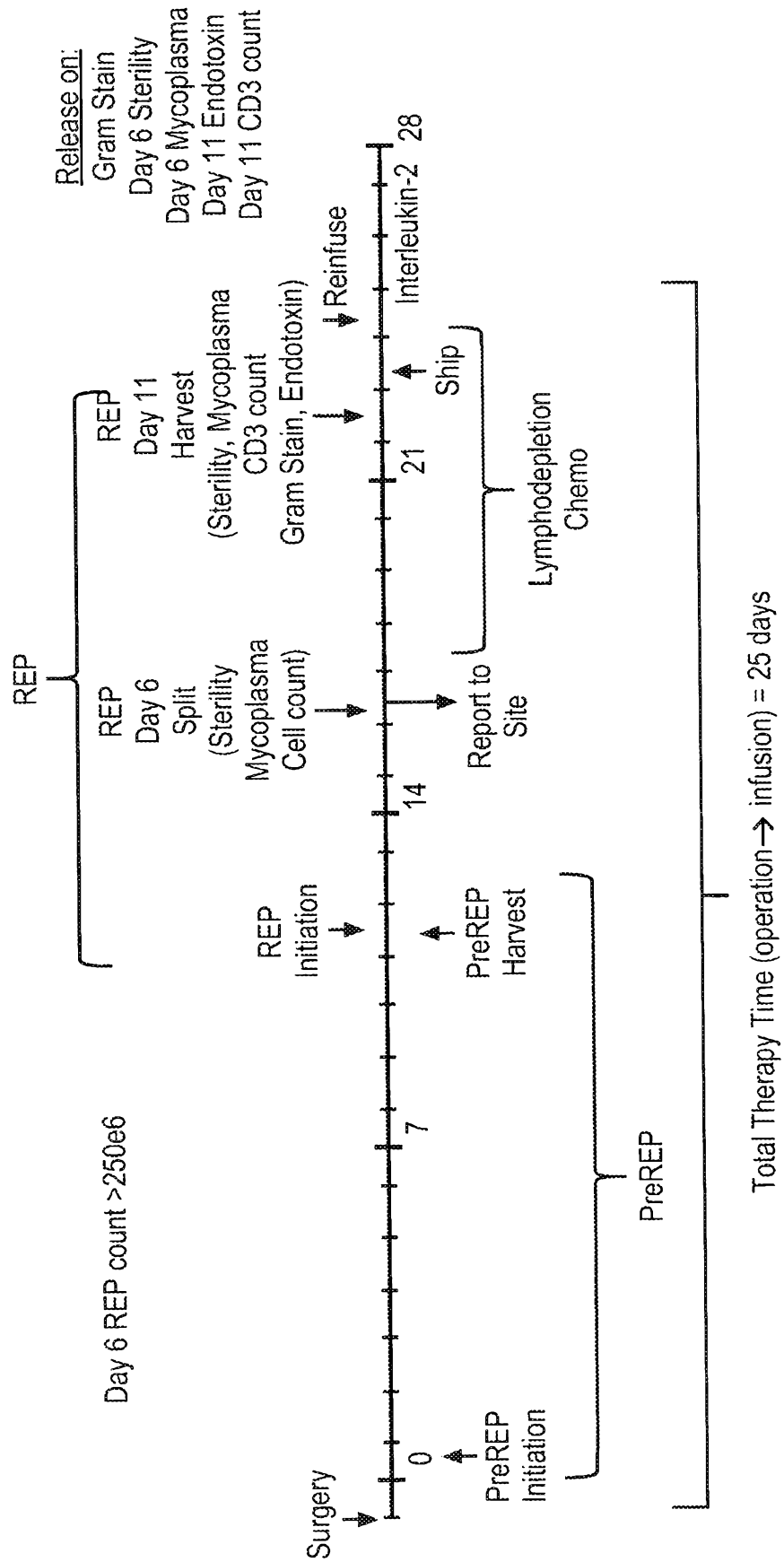

Figure 4

TIL Therapy Timeline- v2A- Day 16 REP >250e6

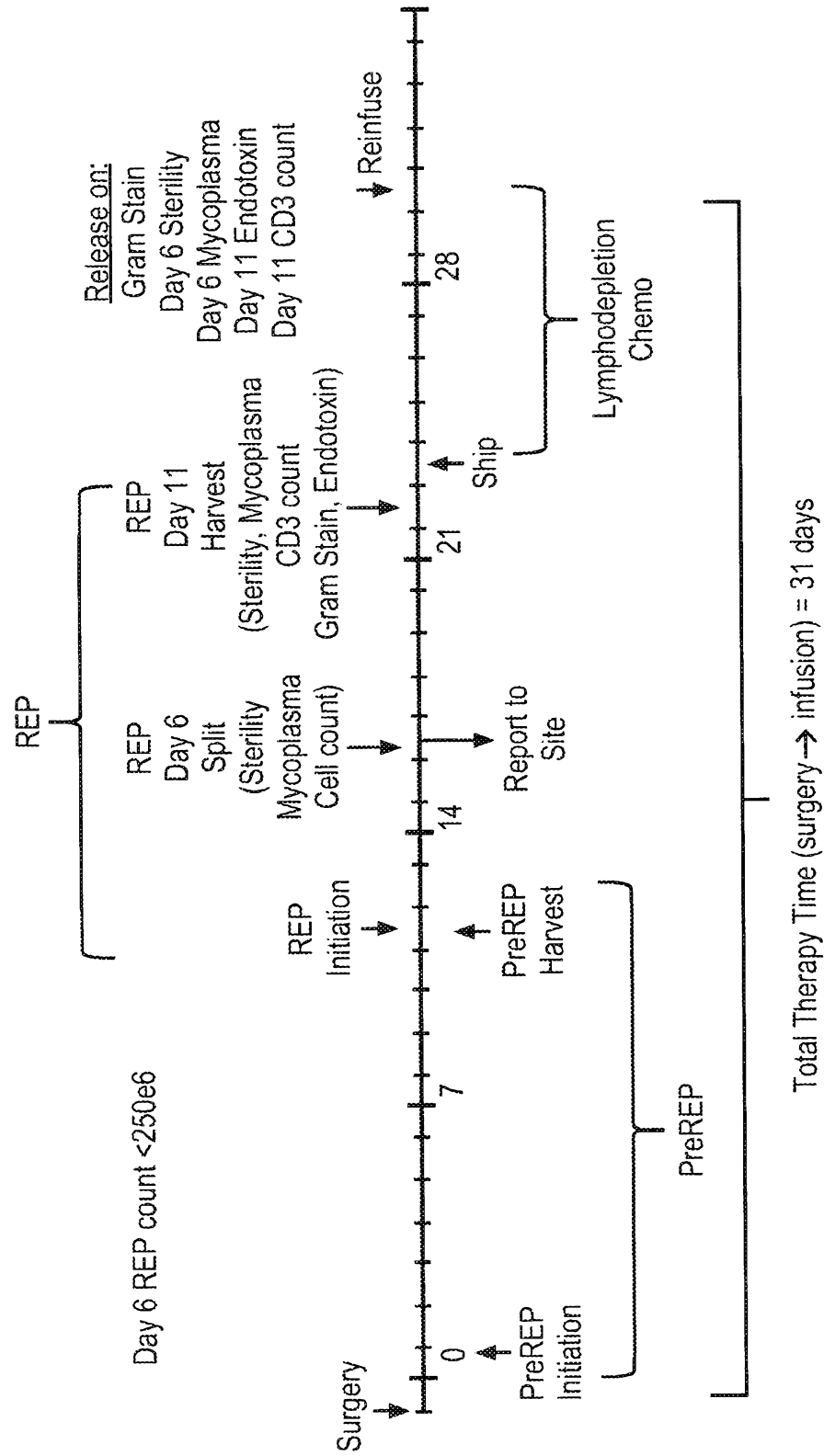

Figure 5

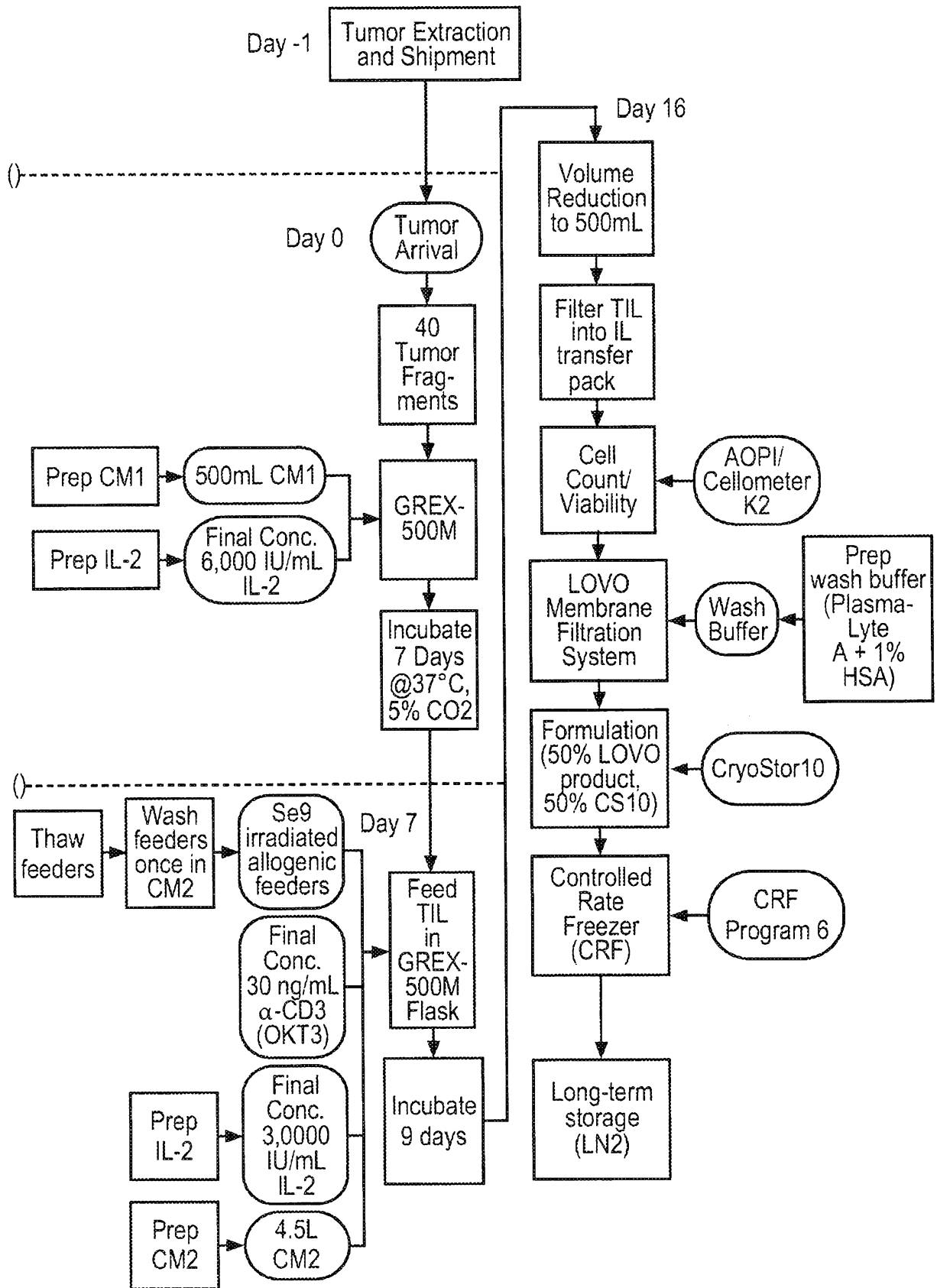
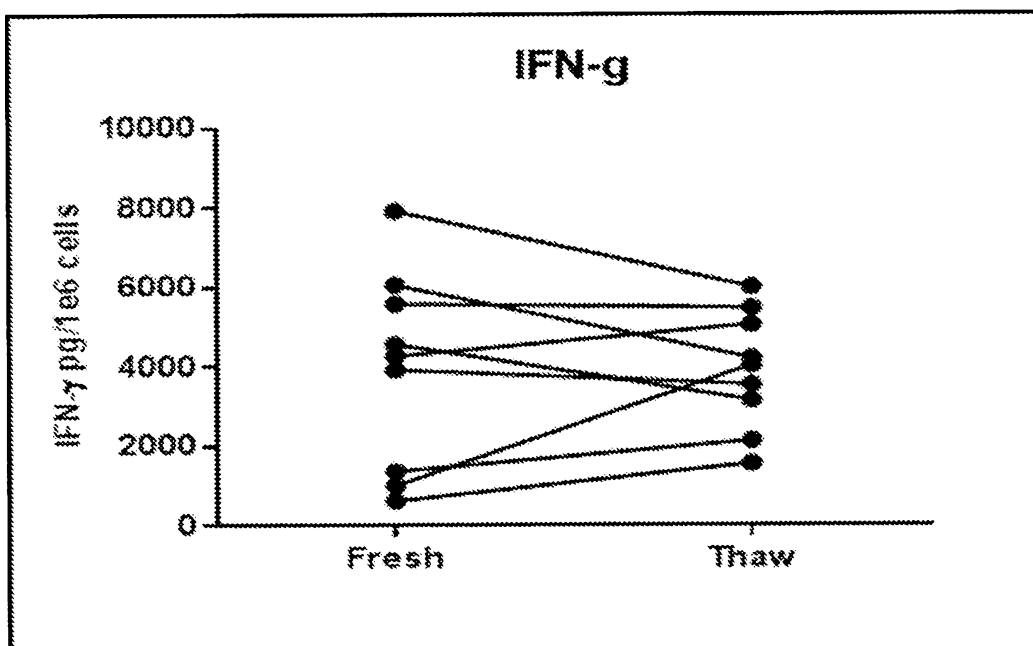

Figure 6

Figure 7

P value	0.9797
P value summary	ns
Significantly different? (P < 0.05)	No
One- or two-tailed P value?	Two-tailed
t, df	t=0.02626 df=8
Number of pairs	9



How effective was the pairing?

Correlation coefficient (r)

P value (one tailed)

P value summary

Was the pairing significantly effective?

Figure 8

P value summary	ns
Significantly different? (P < 0.05)	No
One- or two-tailed P value?	Two-tailed
t, df	t=0.8479 df=7
Number of pairs	8

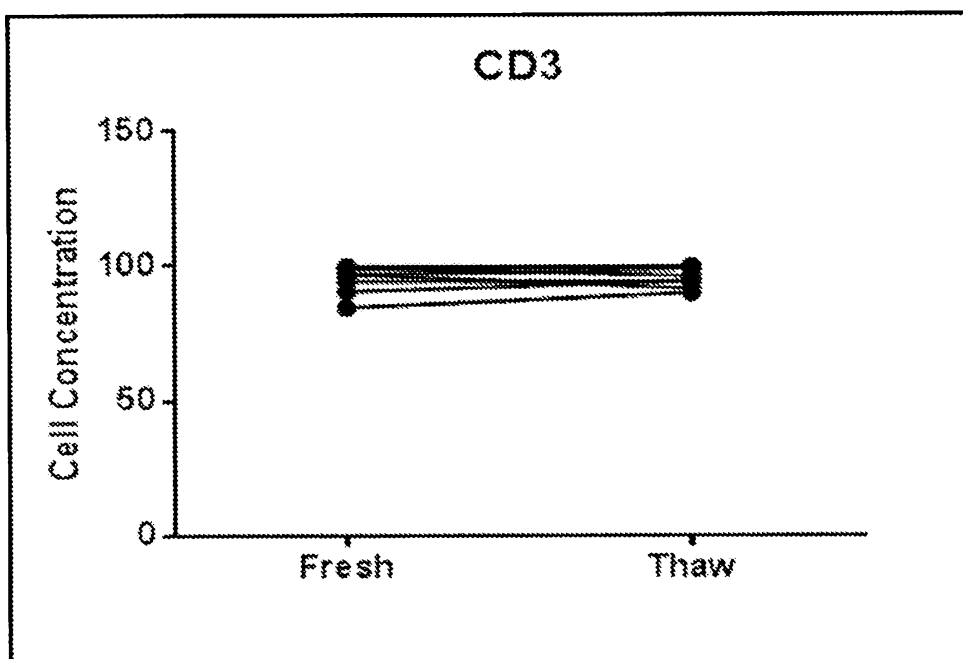

How effective was the pairing?	
Correlation coefficient (r)	0.9711
P value (one tailed)	< 0.0001
P value summary	****
Was the pairing significantly effective?	Yes

Figure 9

P value summary	ns
Significantly different? (P < 0.05)	No
One- or two-tailed P value?	Two-tailed
t, df	t=1.568 df=7
Number of pairs	8

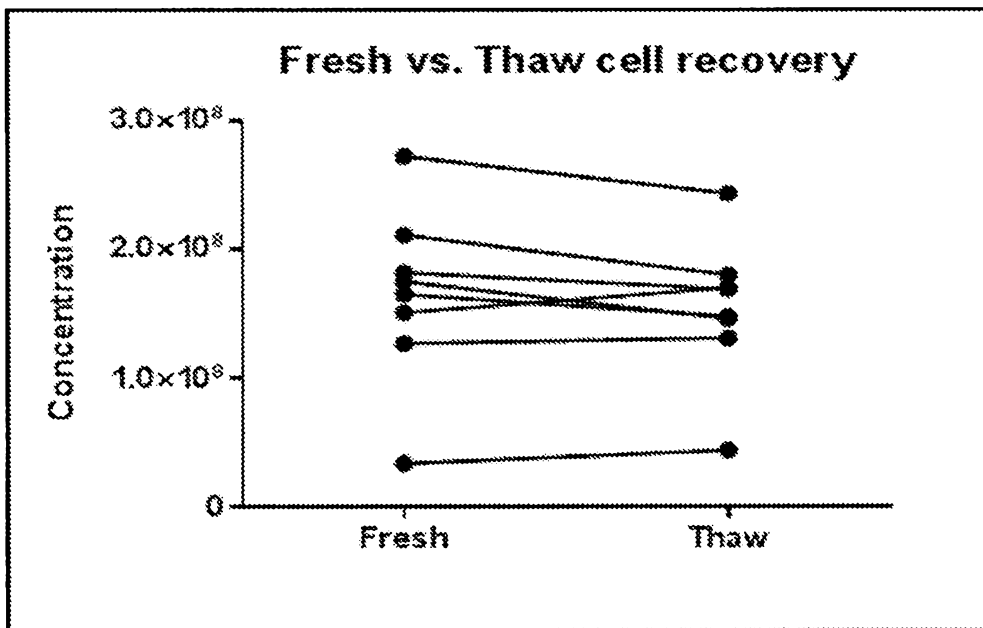

How effective was the pairing?	
Correlation coefficient (r)	0.7448
P value (one tailed)	0.017
P value summary	*
Was the pairing significantly effective?	Yes

Figure 10

P value summary	ns
Significantly different? (P < 0.05)	No
One- or two-tailed P value?	Two-tailed
t, df	t=1.596 df=7
Number of pairs	8

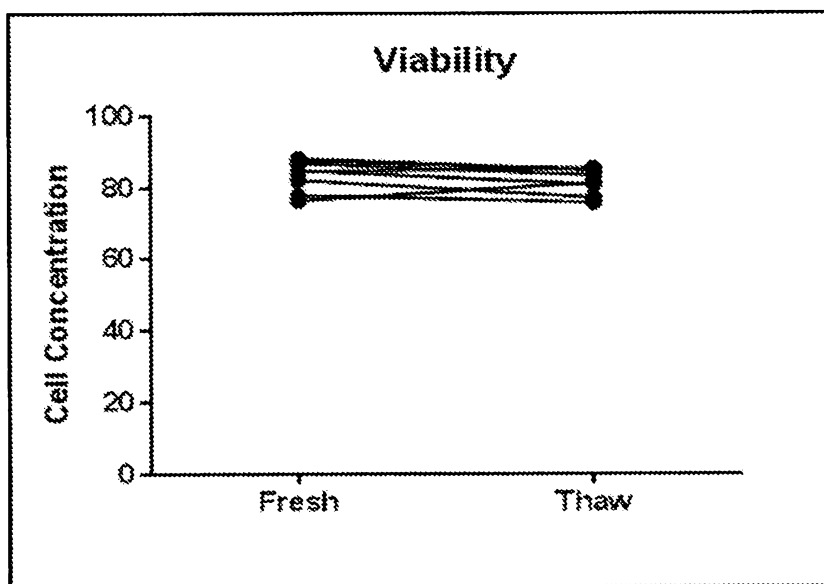

How effective was the pairing?	
Correlation coefficient (r)	0.6932
P value (one tailed)	0.0283
P value summary	*
Was the pairing significantly effective?	Yes

11/136

Day 0 -  
Tumor Isolation

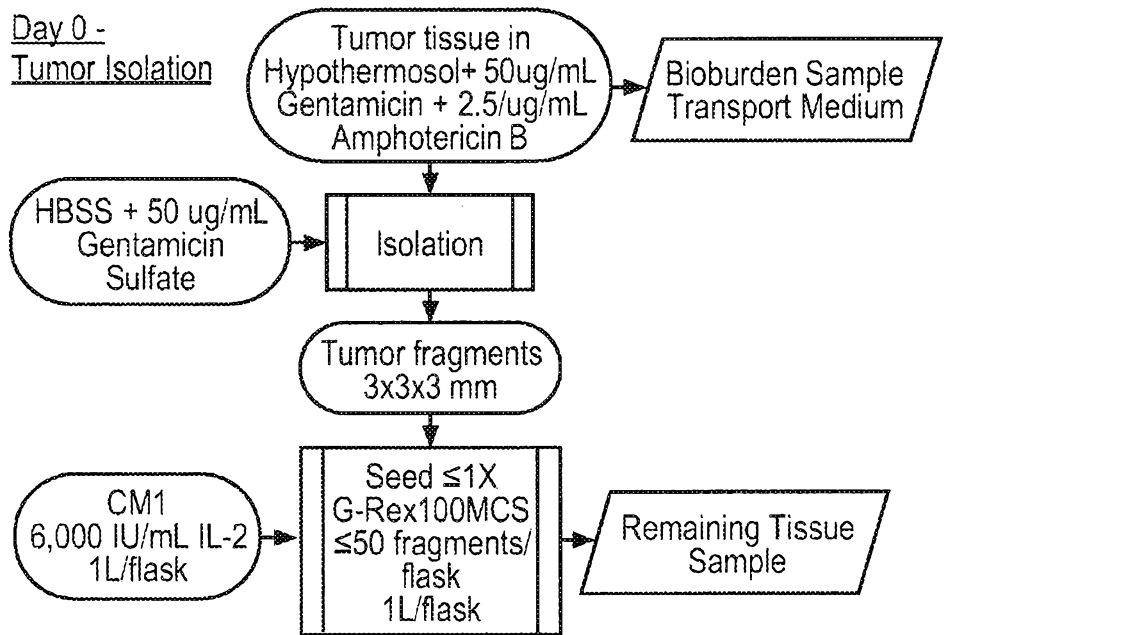

Day 11 REP Initiation

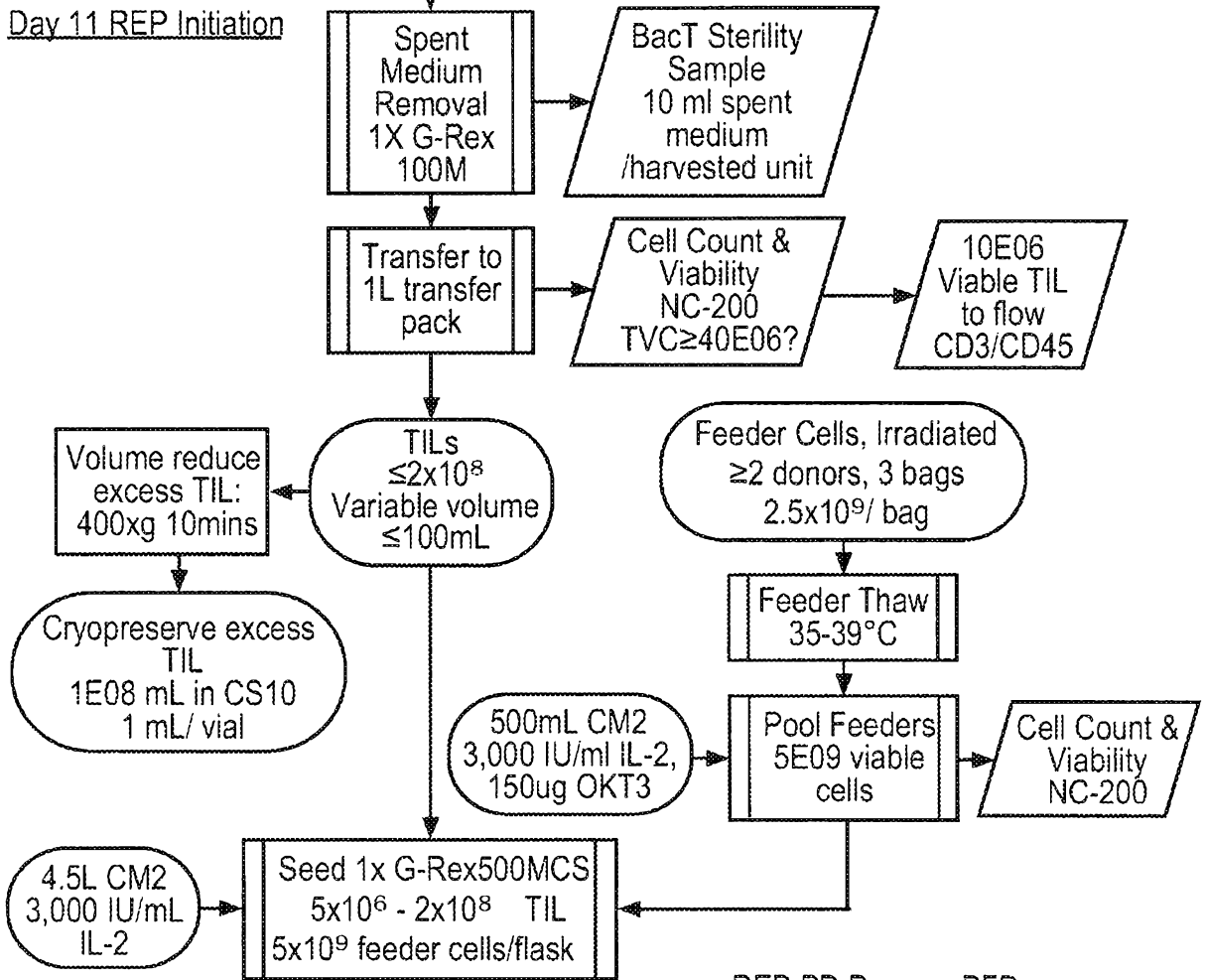

Figure 11b

REP PD Process PFD  
Page 1/3

Figure 11a

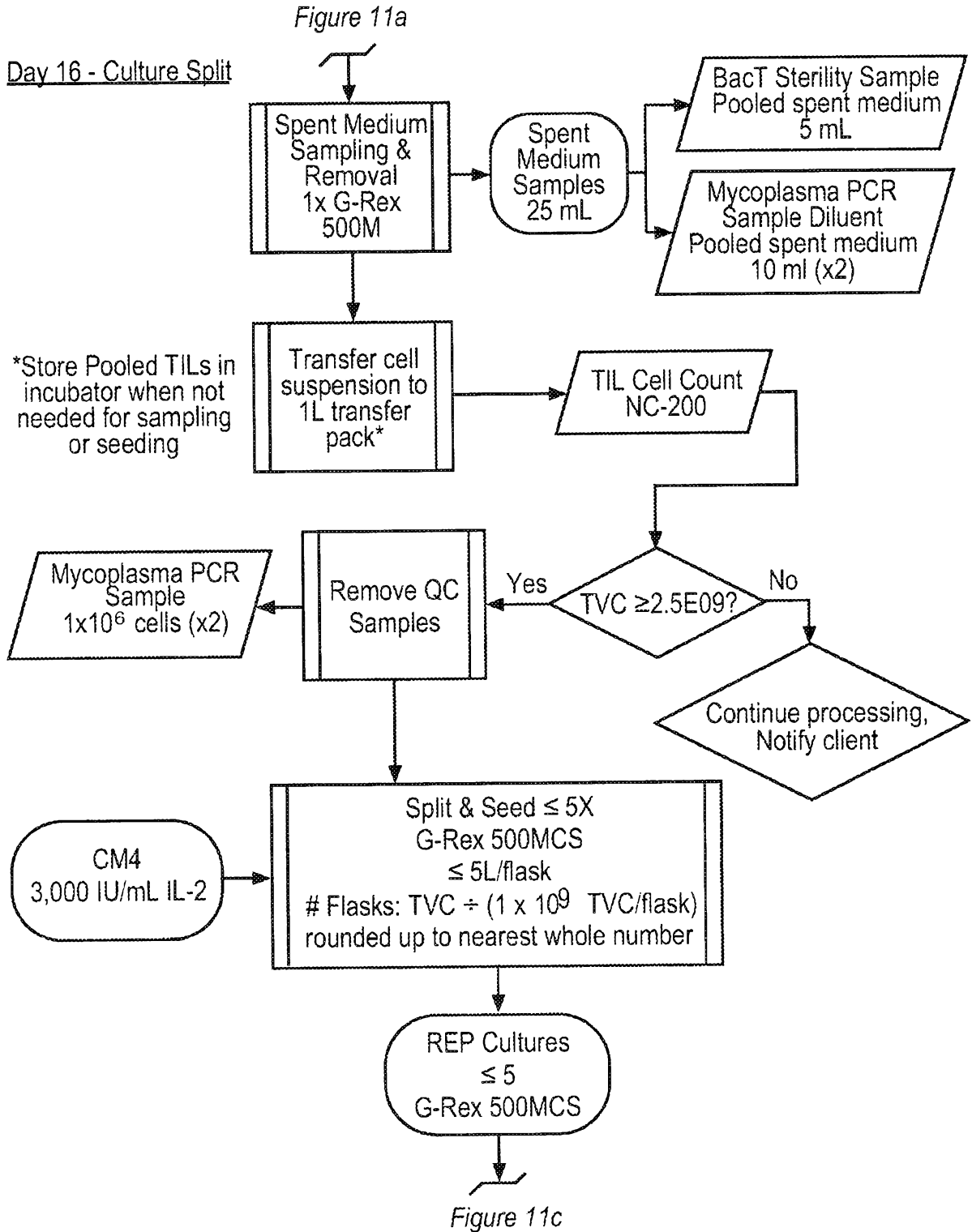

Figure 11b

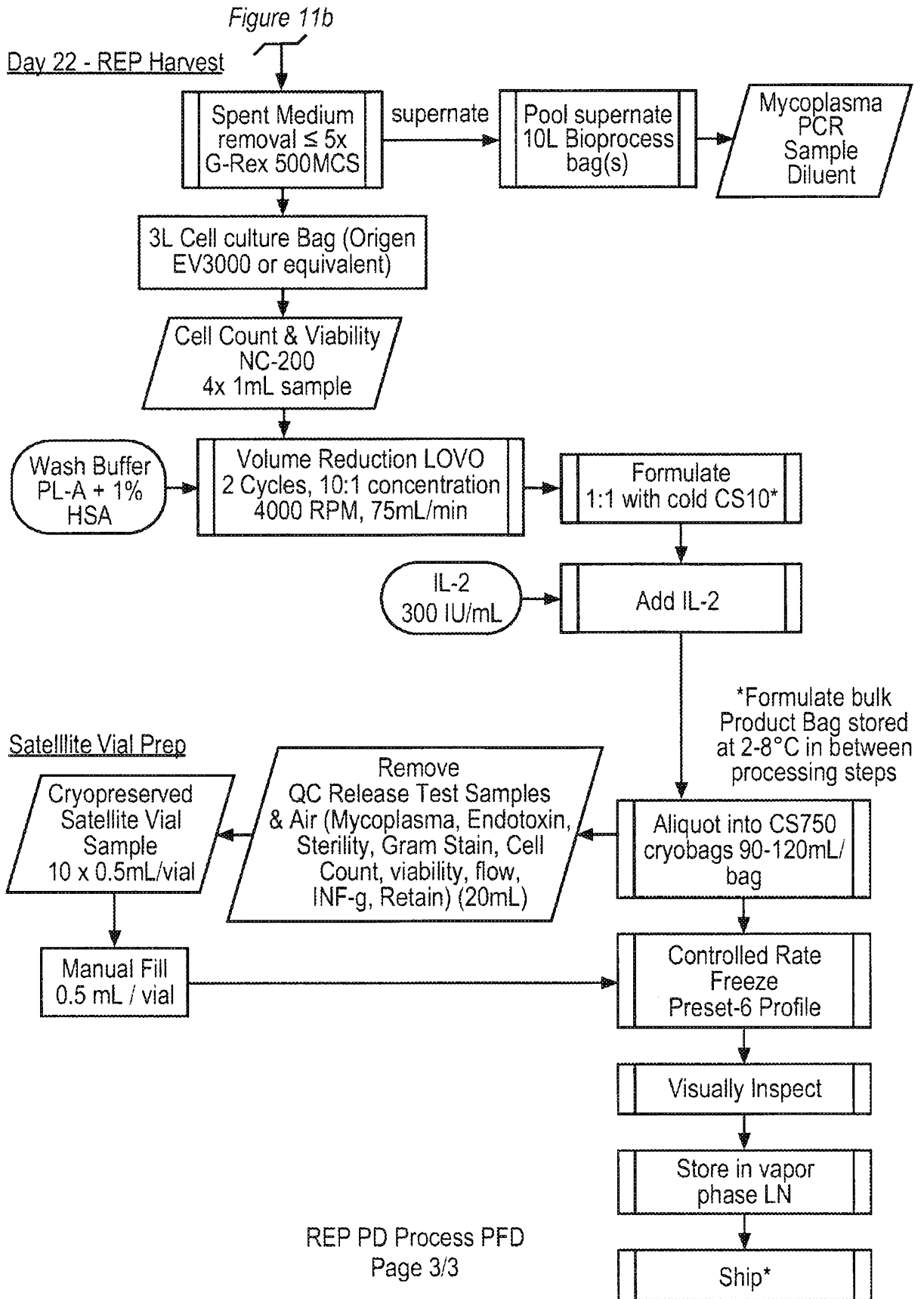

Figure 11c

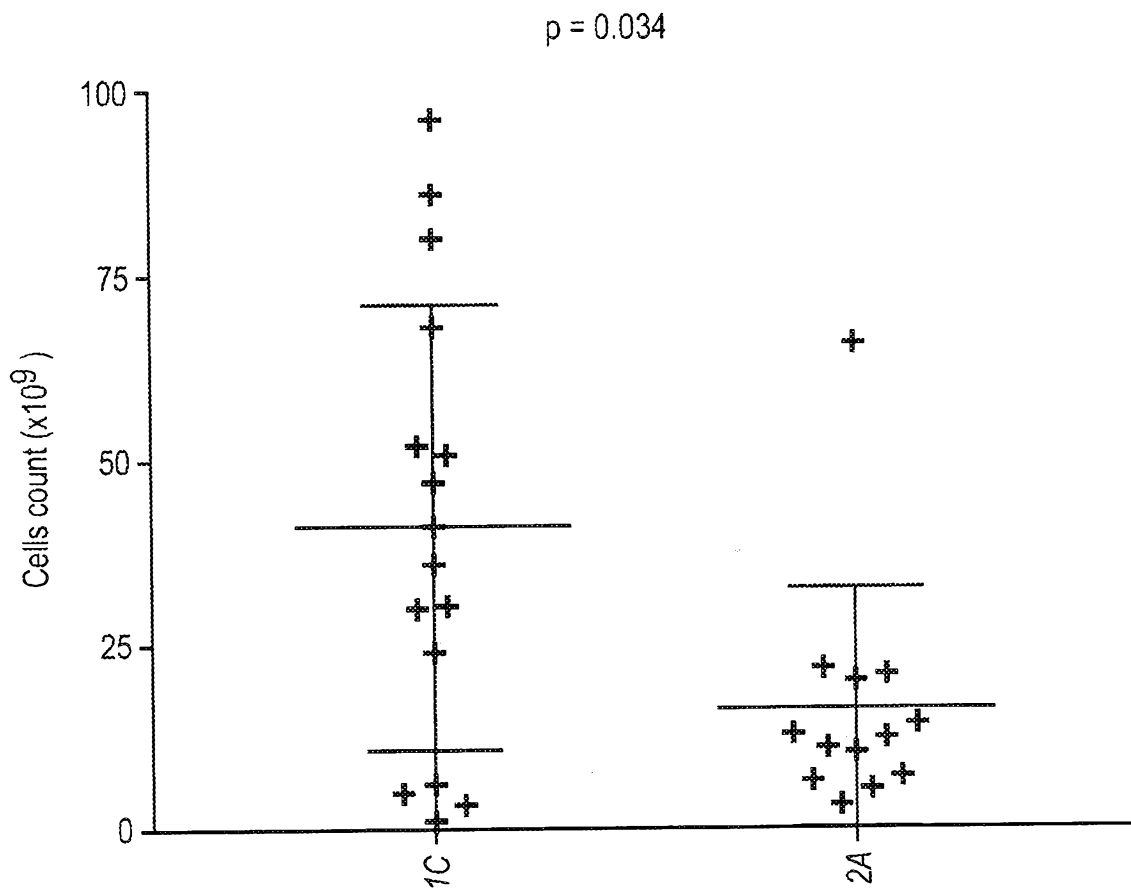

Figure 12

15/136

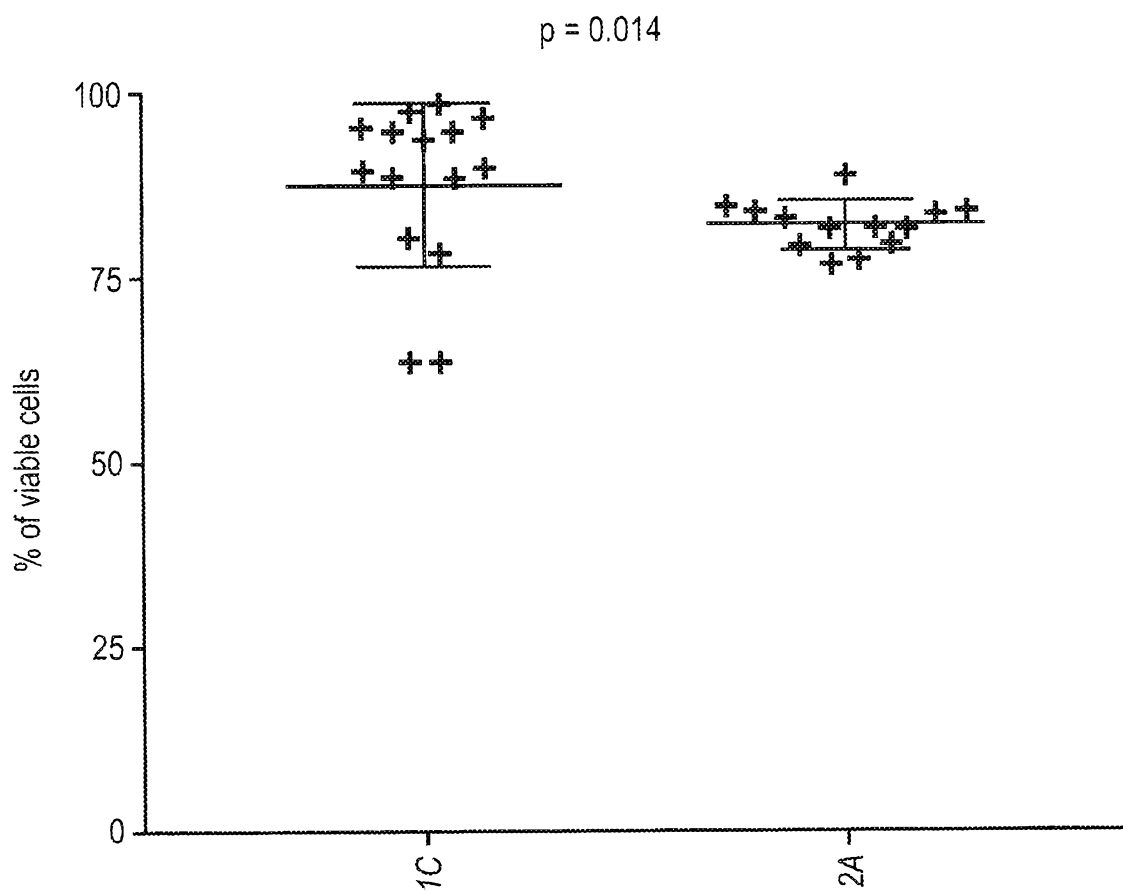

Figure 13

16/136

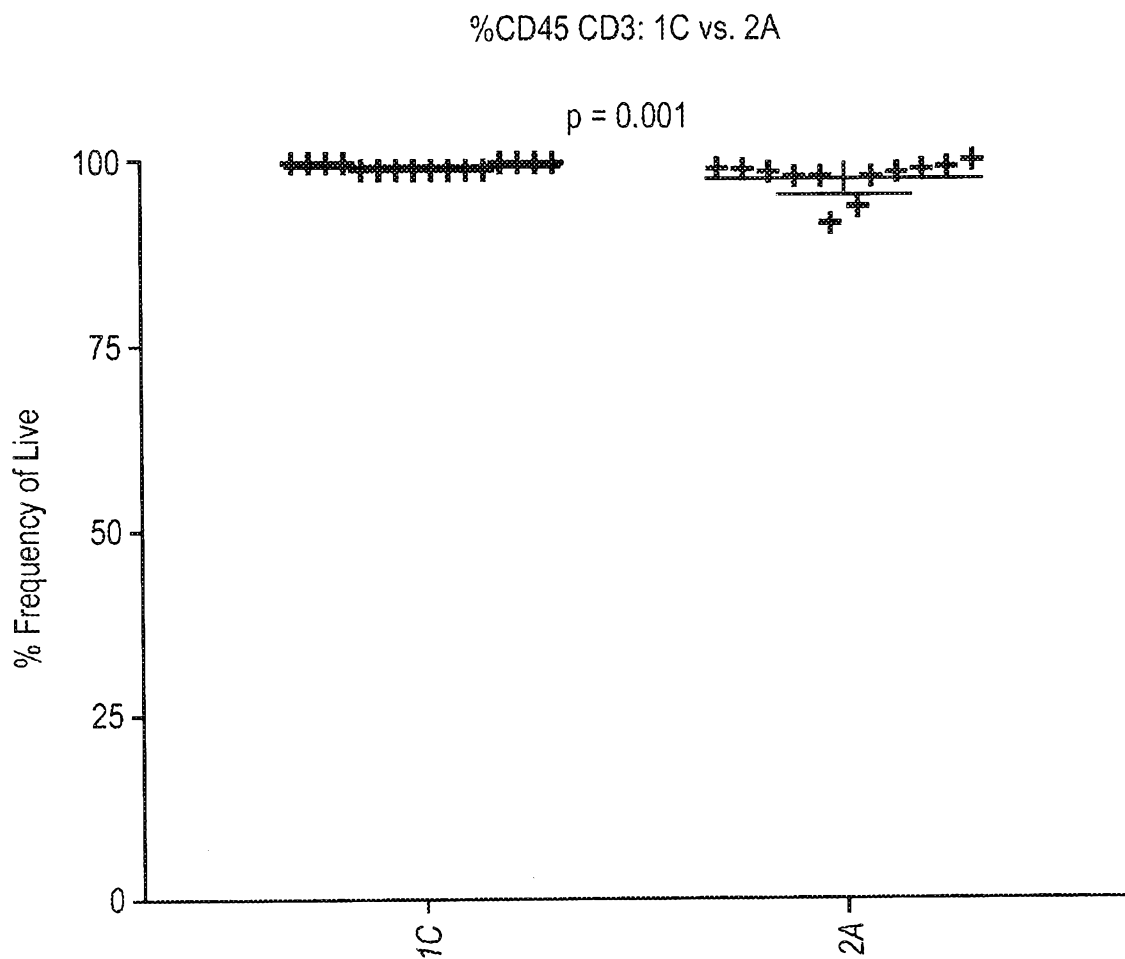

Figure 14

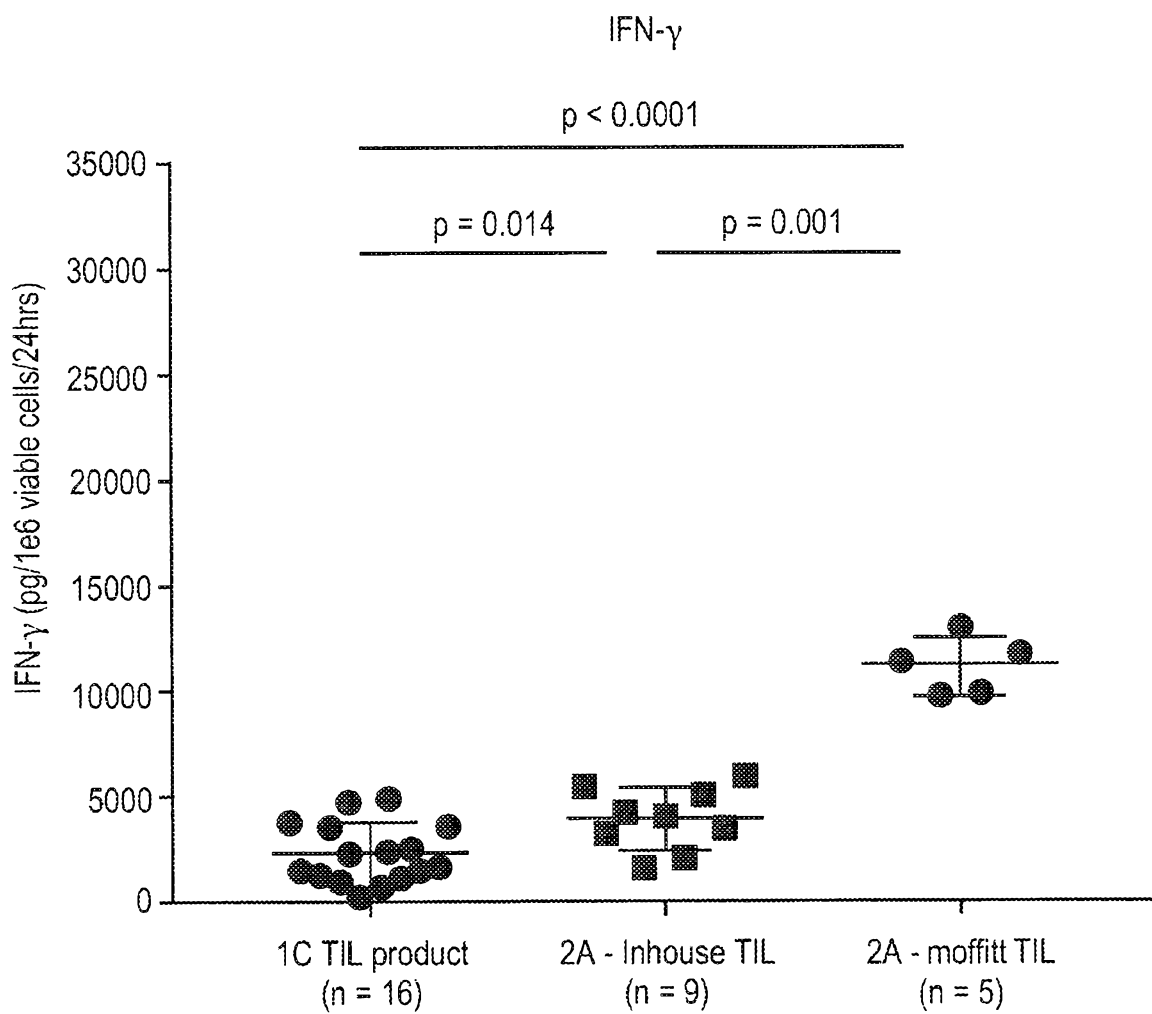

Figure 15

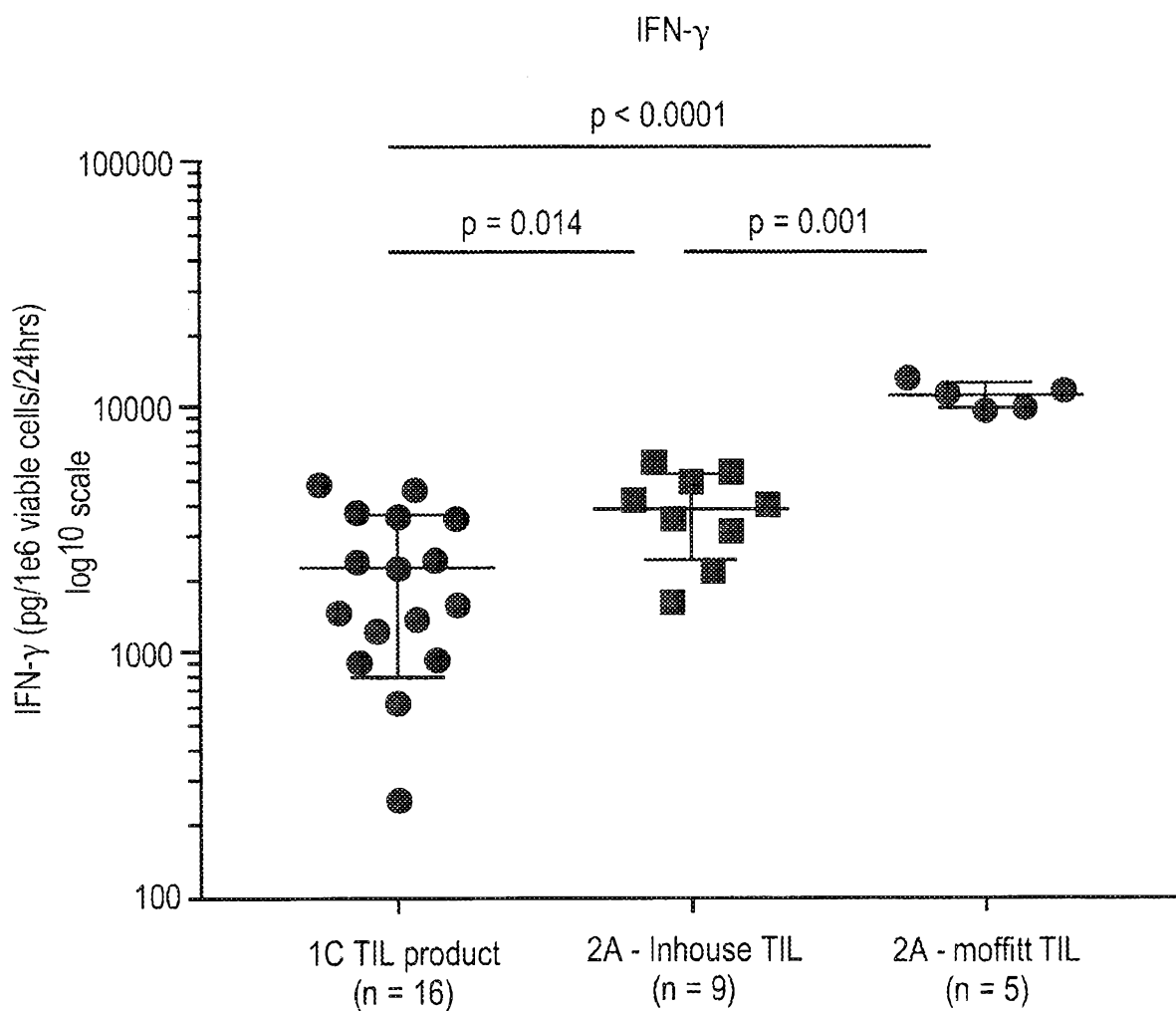

Figure 16

TCRa/b and NK: 1C vs. 2A

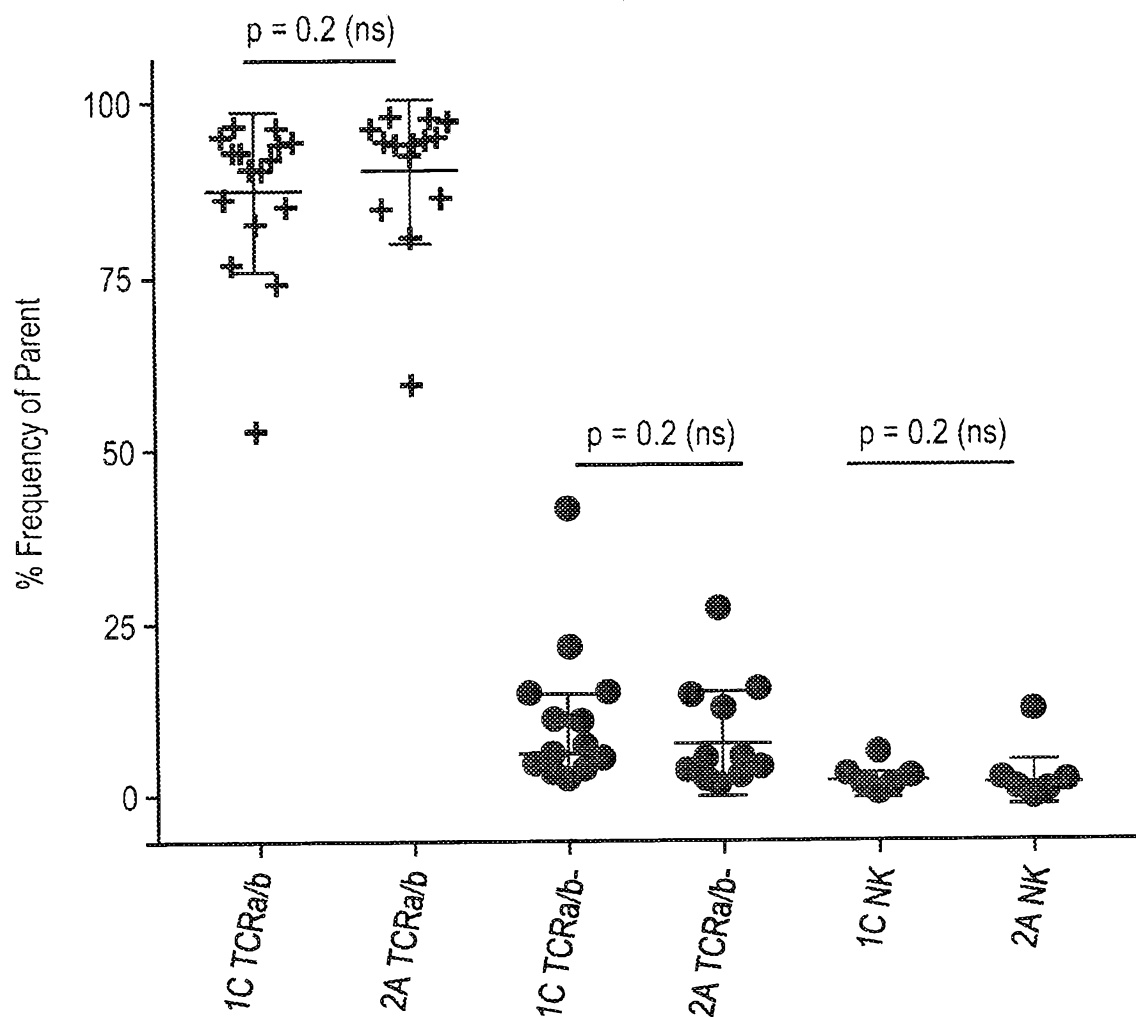

Figure 17



21/136

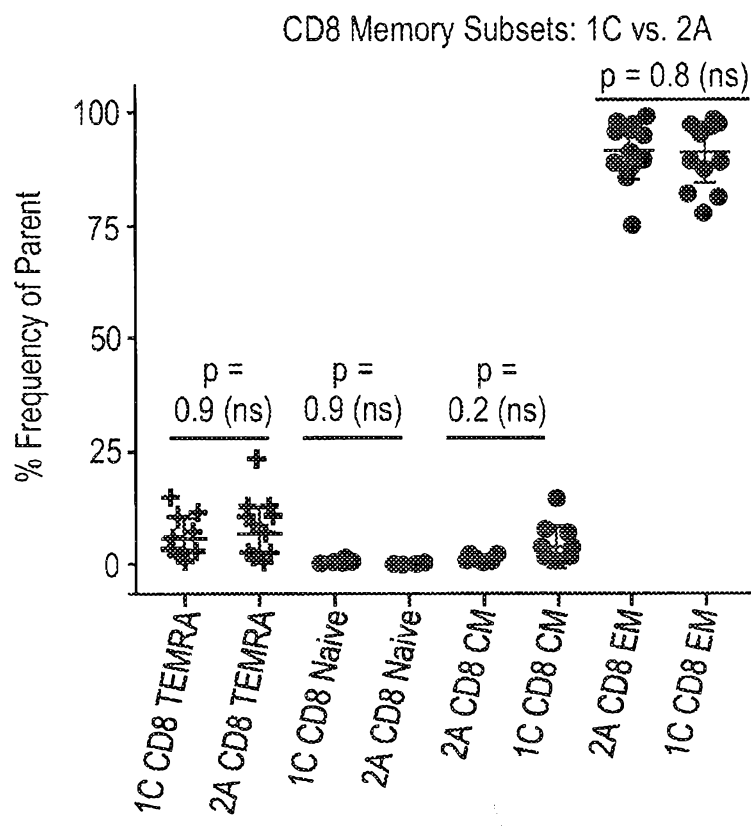
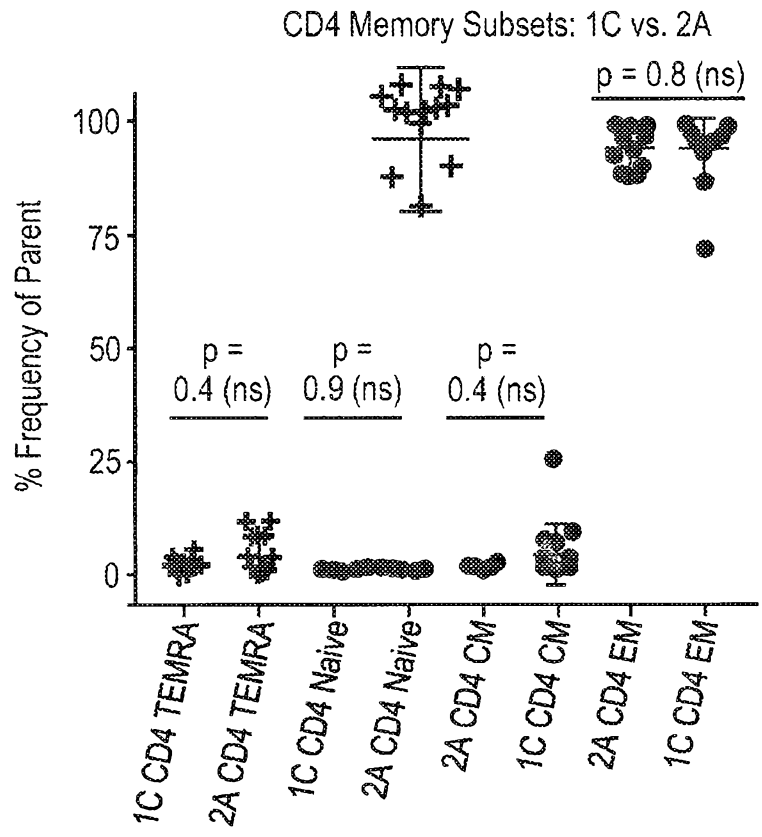

Figure 19

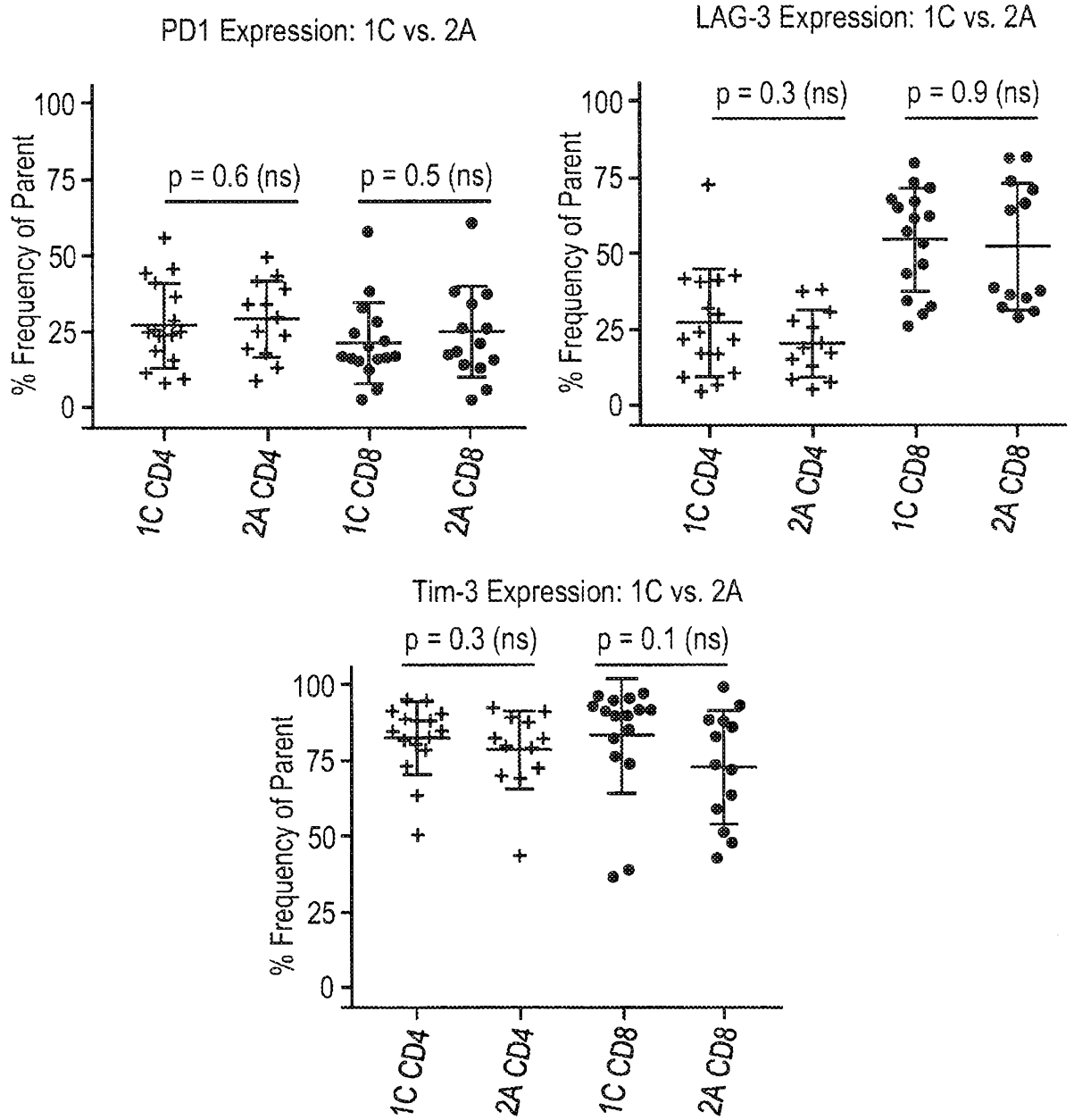

Figure 20

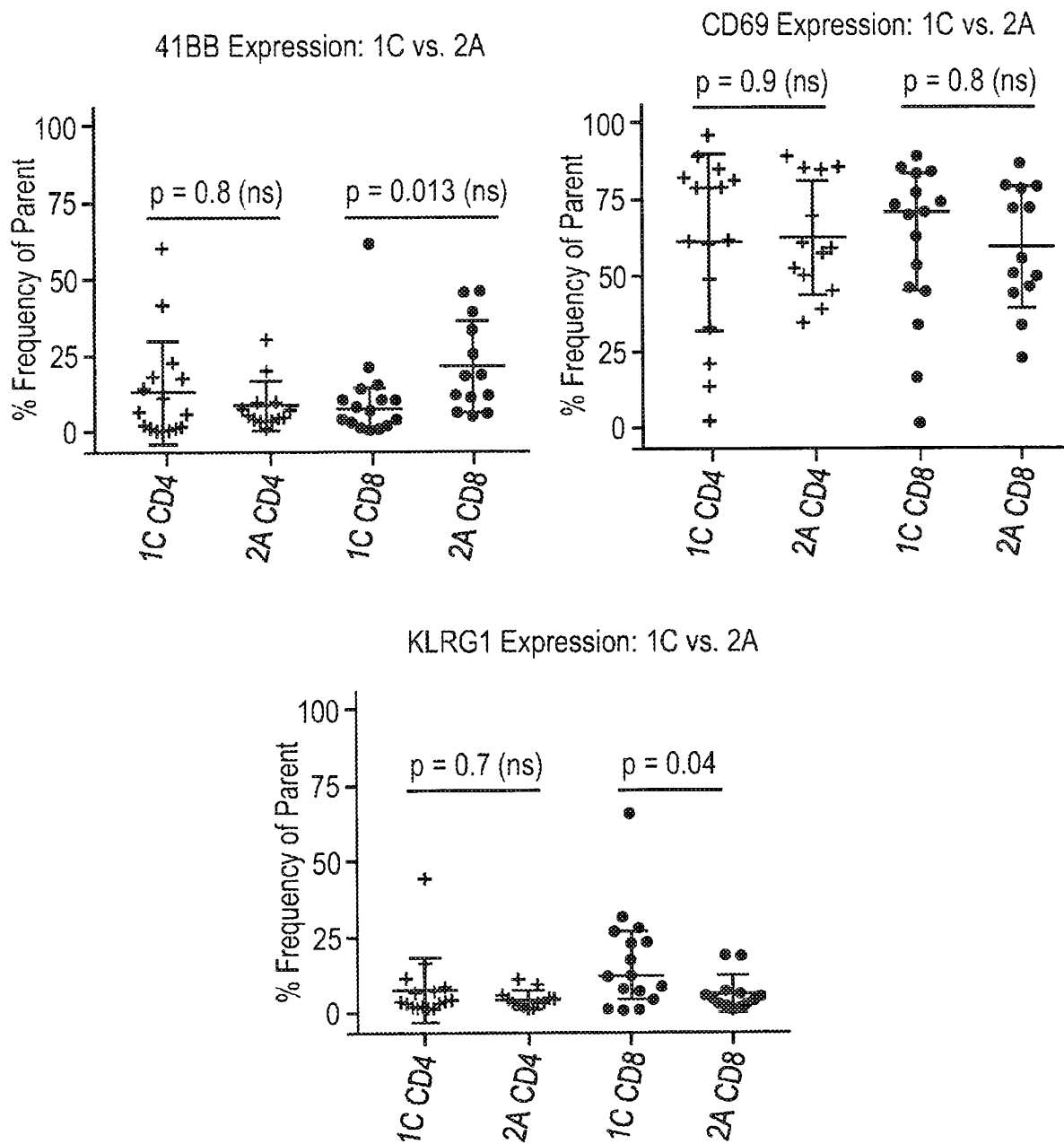

Figure 21

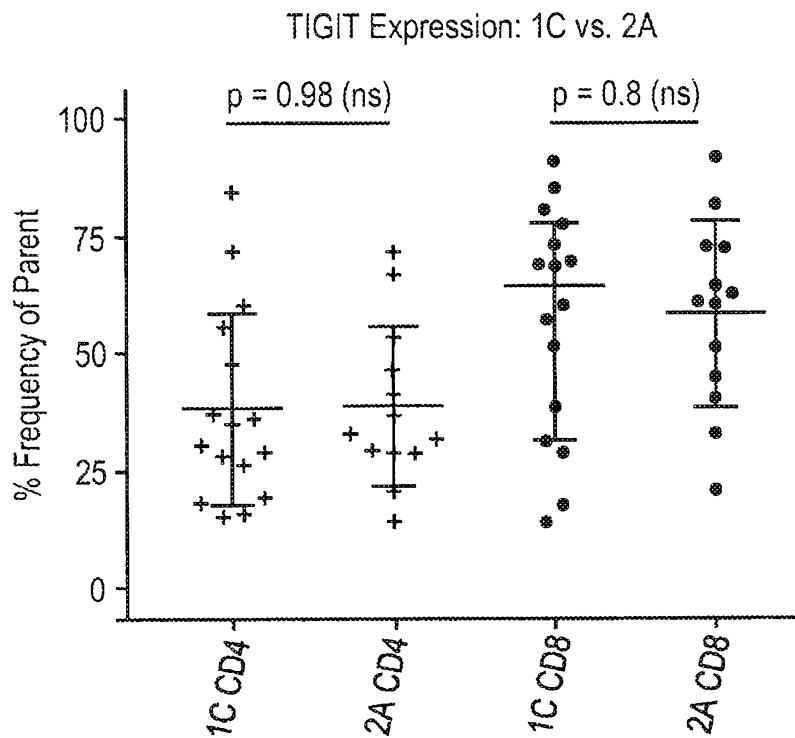

Figure 22

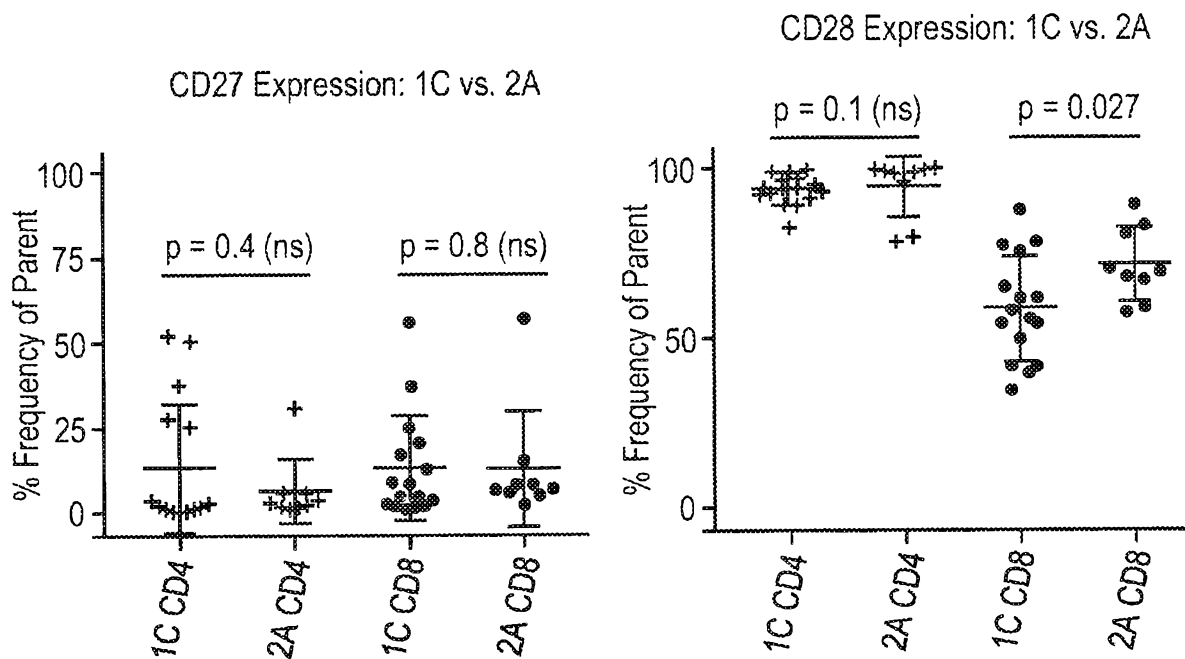

Figure 23

26/136

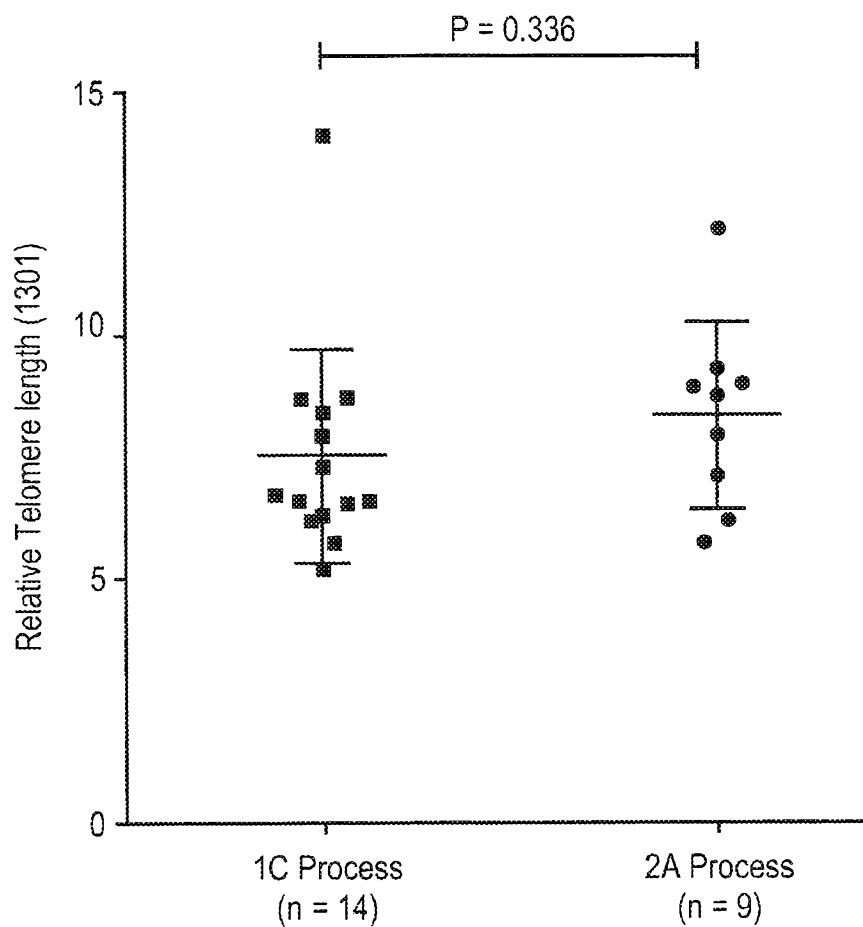

Figure 24

27/136

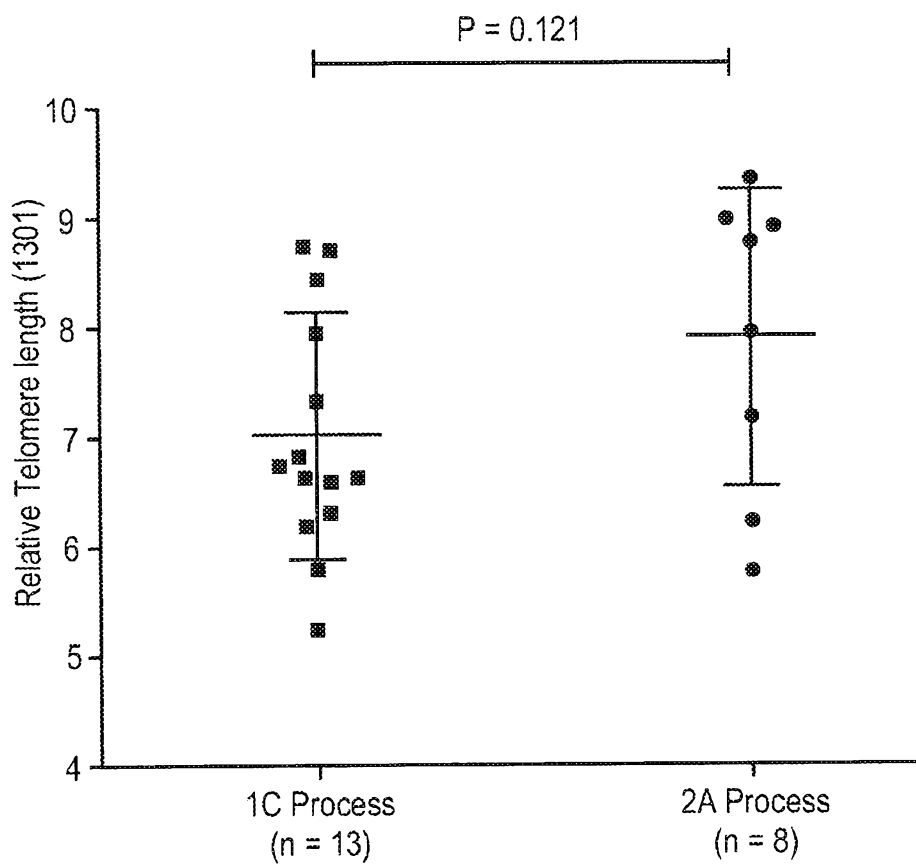
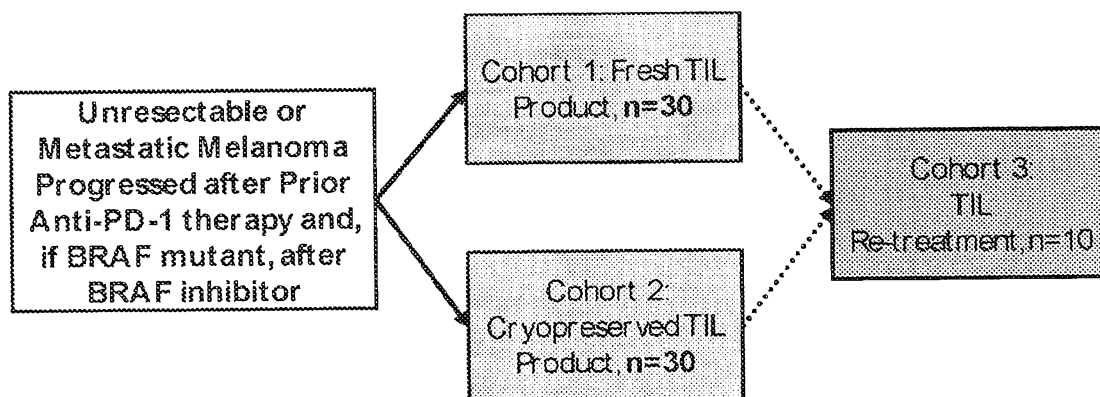

Figure 25

Figure 26



**Figure 27**

**Process 2A: about 22 days from Steps A - E**

**1. STEP A**

Obtain Patient Tumor Sample

**2. STEP B**

Fragmentation and First Expansion

3 days to 14 days

**3. STEP C**

First Expansion to Second Expansion Transition

No Storage and Closed System

**4. STEP D**

Second Expansion

IL-2, OKT-3, and antigen-presenting feeder cells

Closed System

**5. STEP E**

Harvest TILS from Step D

Closed System

**6. STEP F**

Final Formulation and/or Transfer to Infusion Bag

(optionally cryopreserve)

30/136

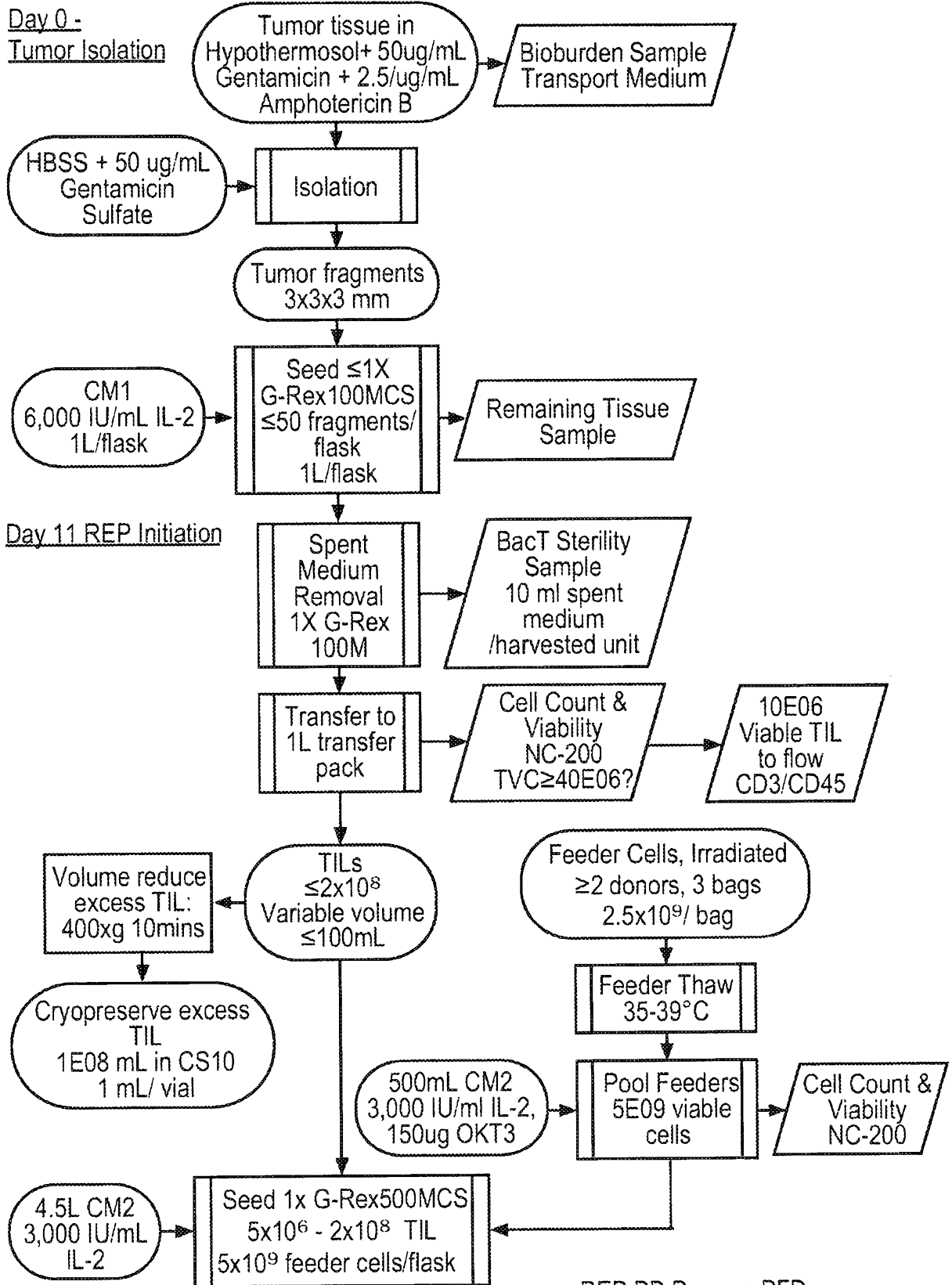
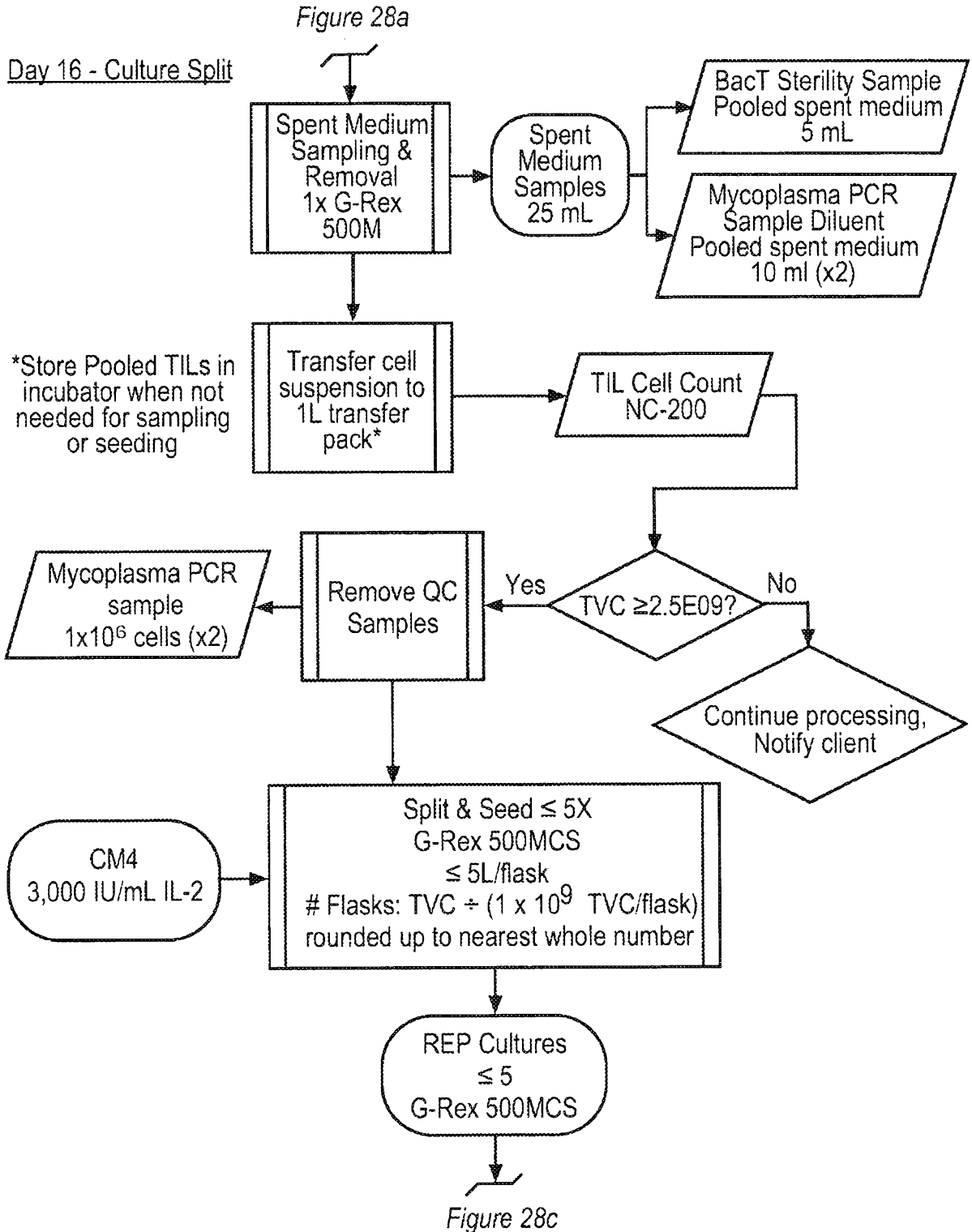
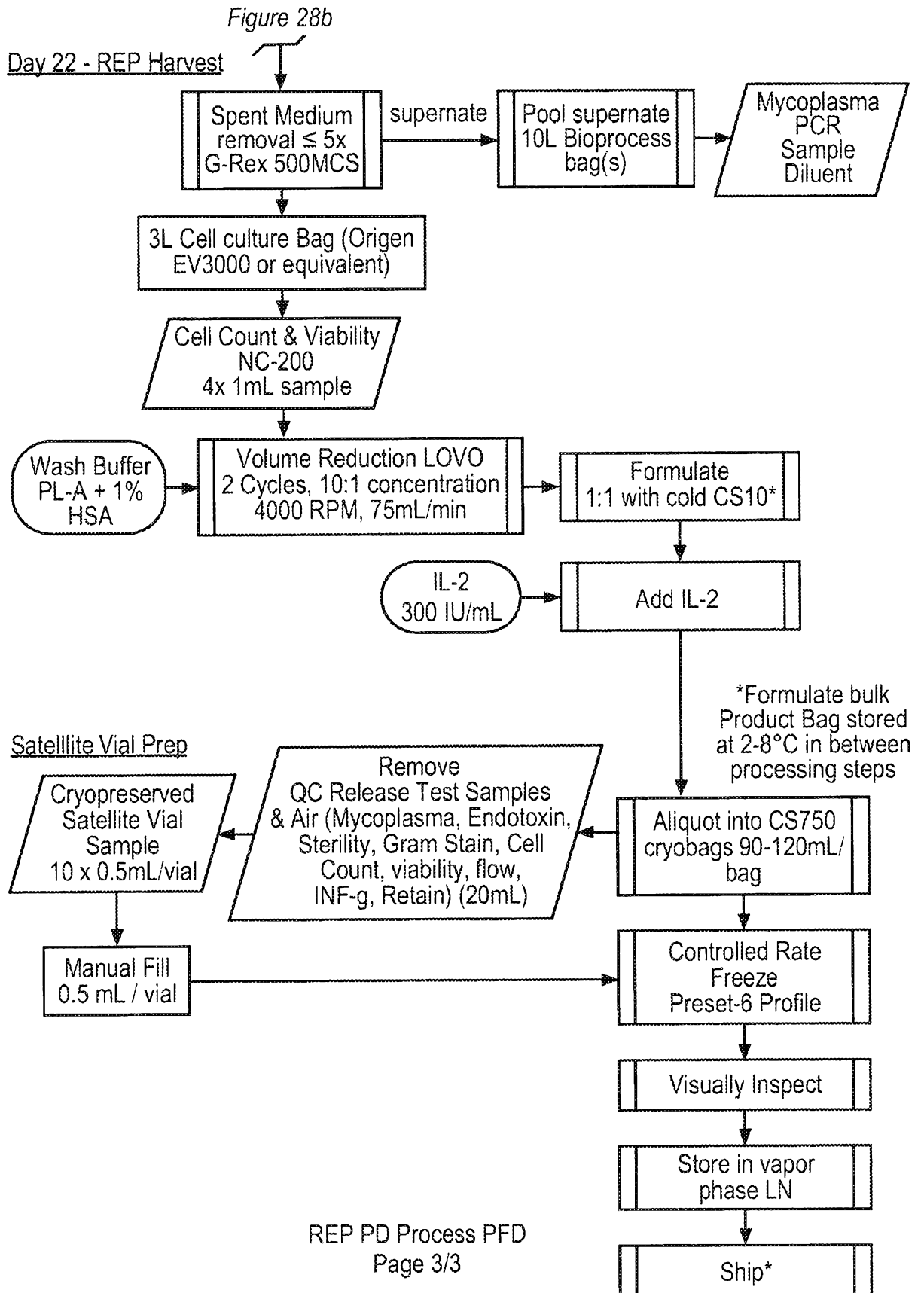

Figure 28b

REP PD Process PFD  
Page 1/3  
Figure 28a





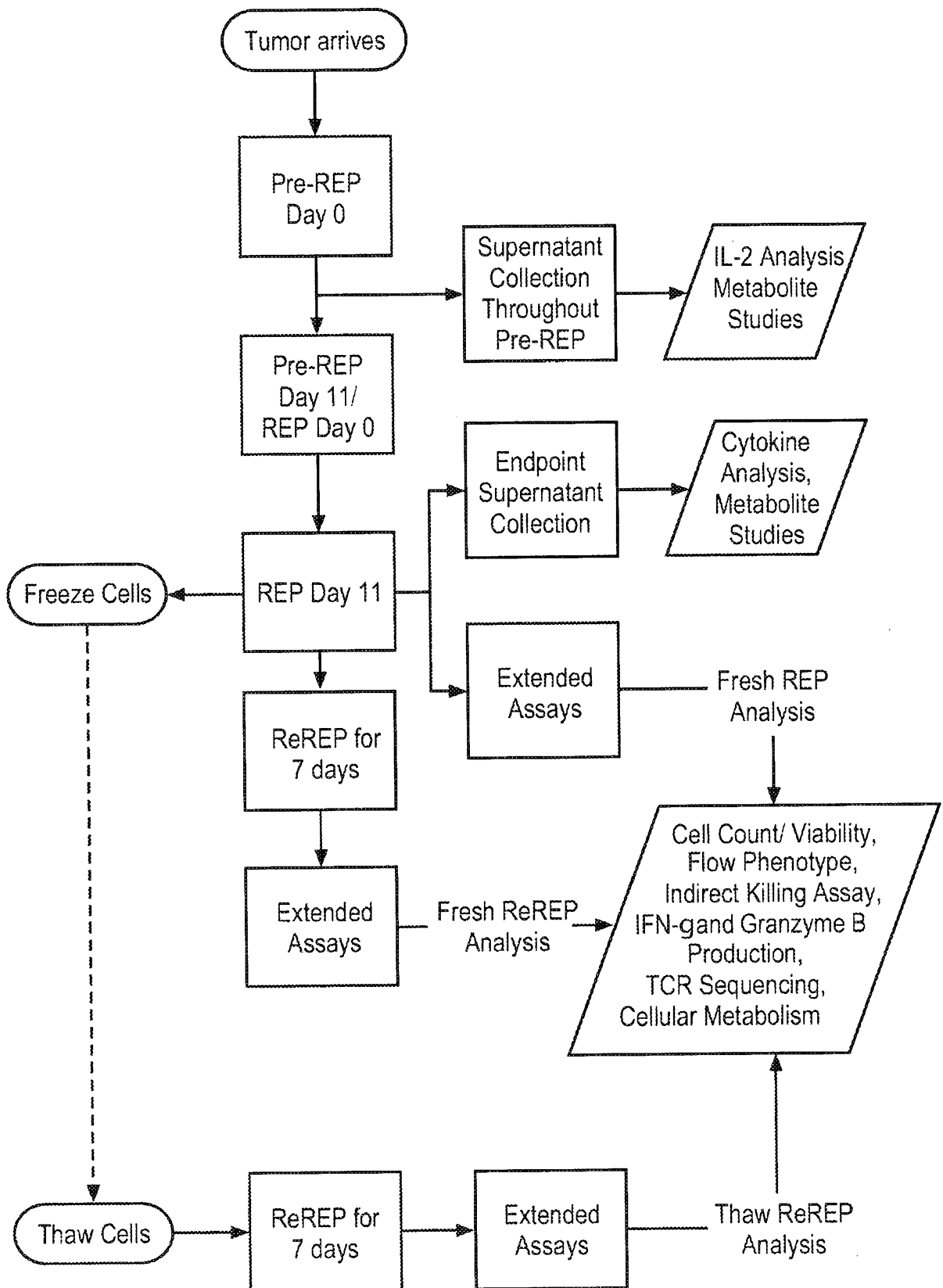

Figure 29

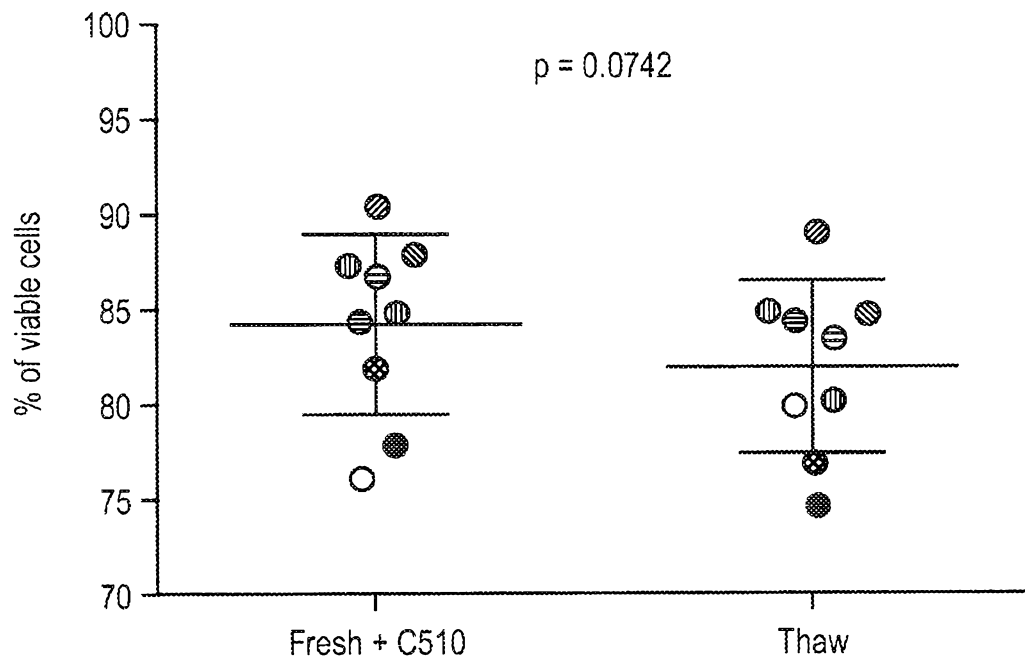

Figure 30

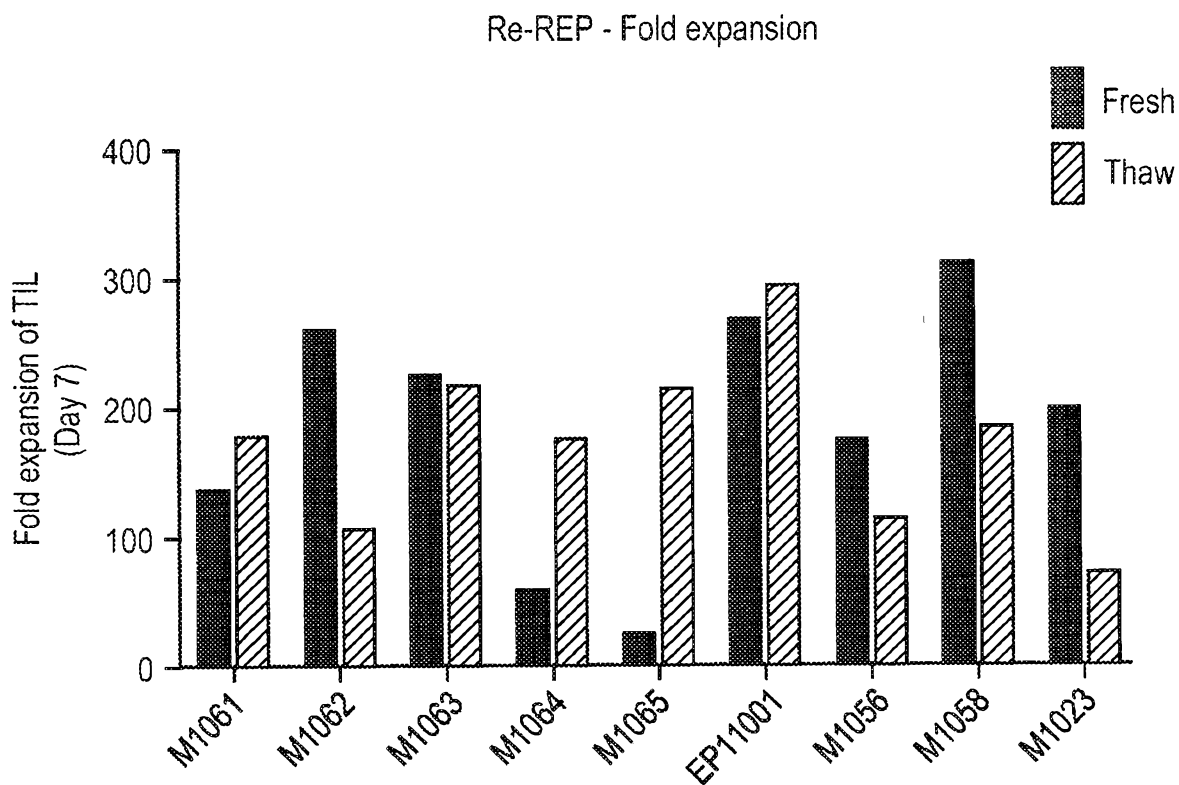

Figure 31

Normal Blood Values	
Glucose	0.7-1g/l
Glutamine	0.3-0.65mmol/l
Sodium	135-145mol/l
Potassium	3.5-5.0mmol/l
Lactic Acid	0.060-.16g/l
Ammonia	.023-.047mmol/l

*Figure 32*

37/136

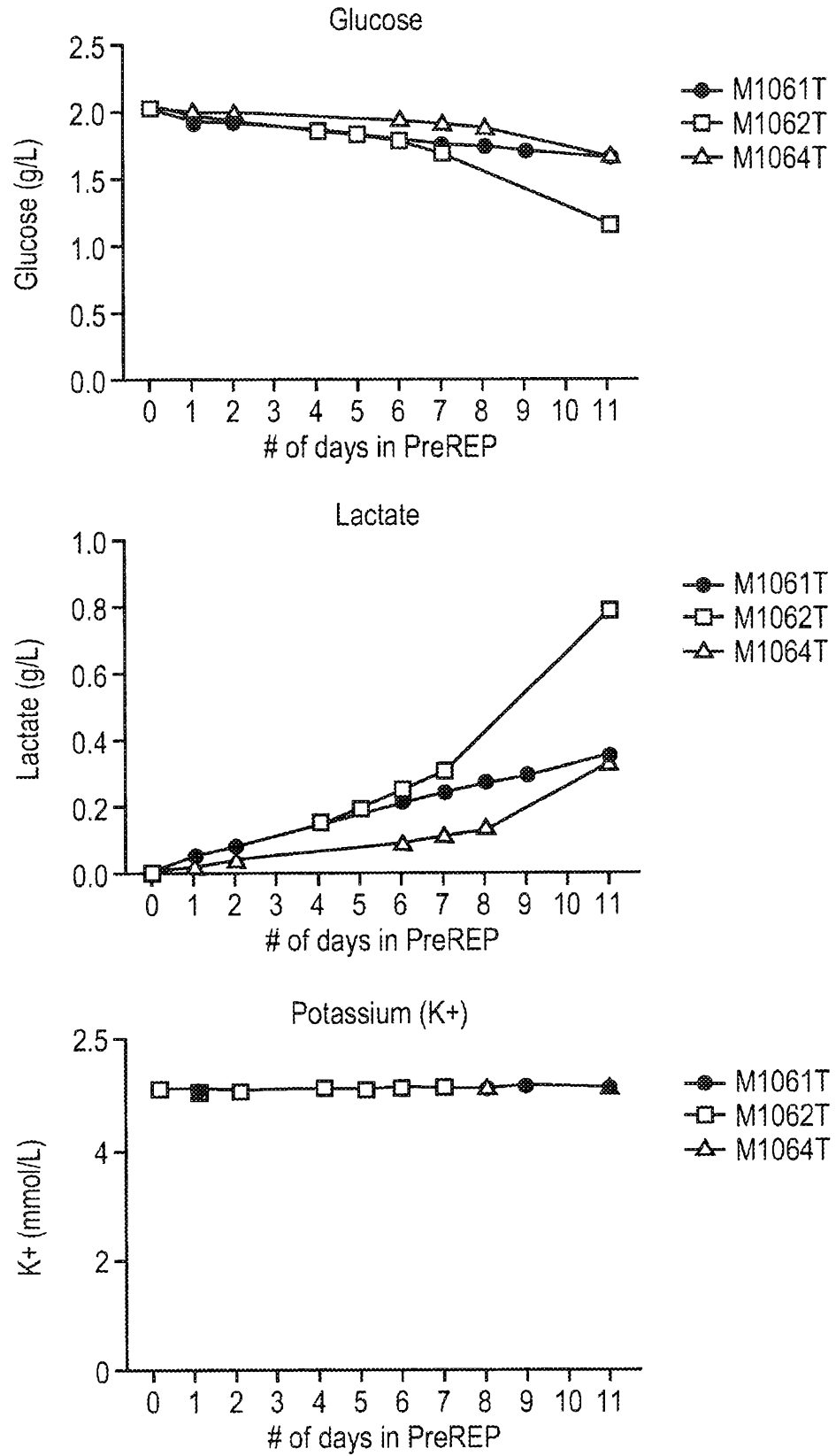

Figure 33a

38/136

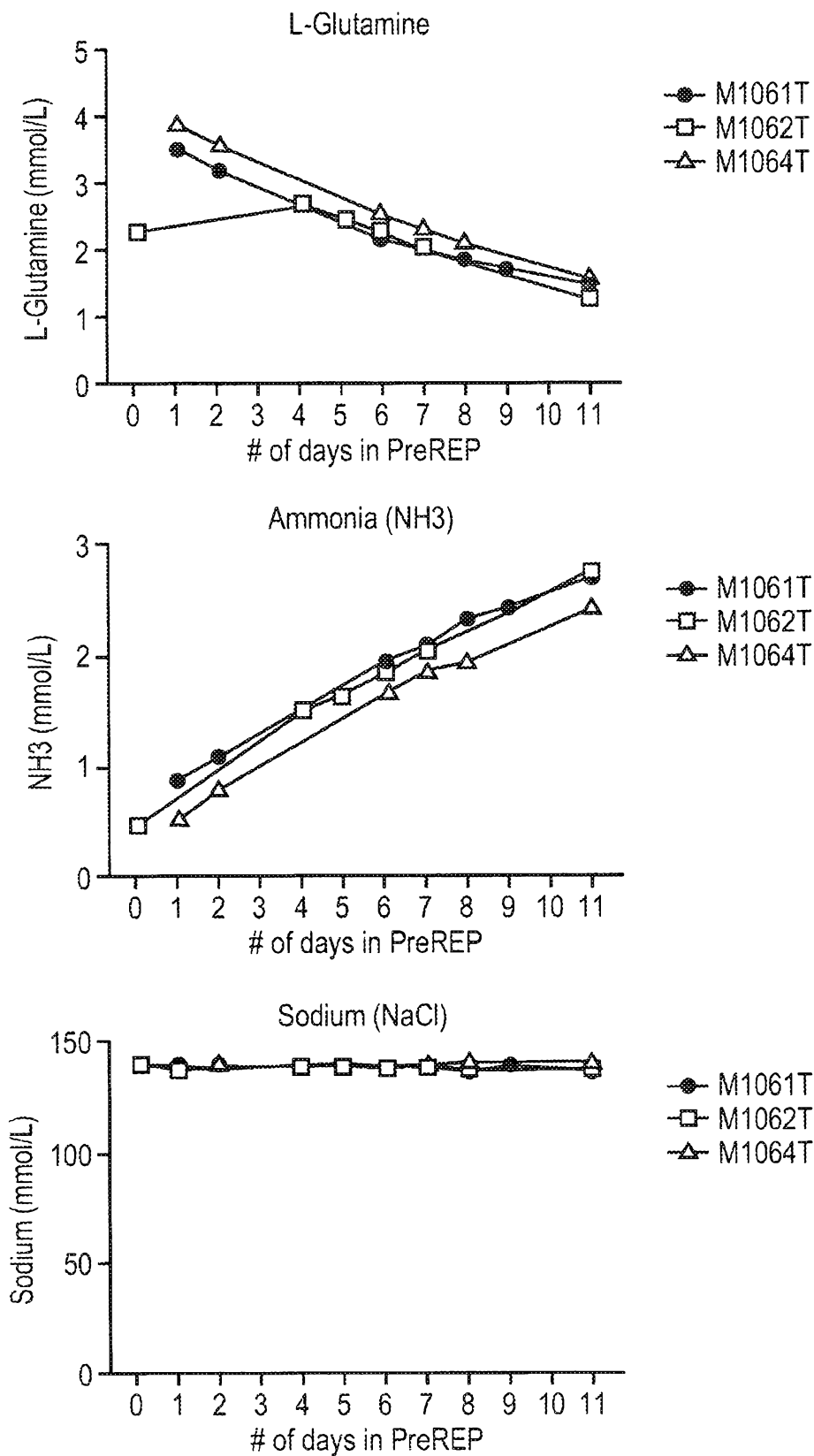

Figure 33b

39/136

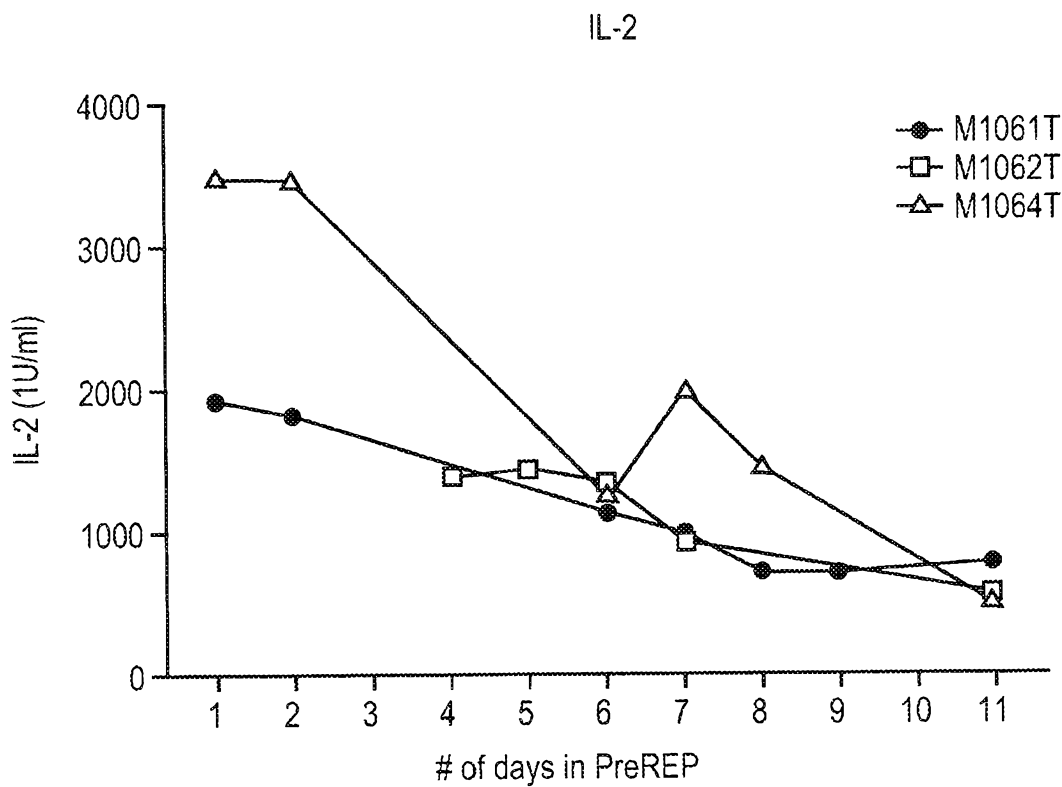

Figure 34

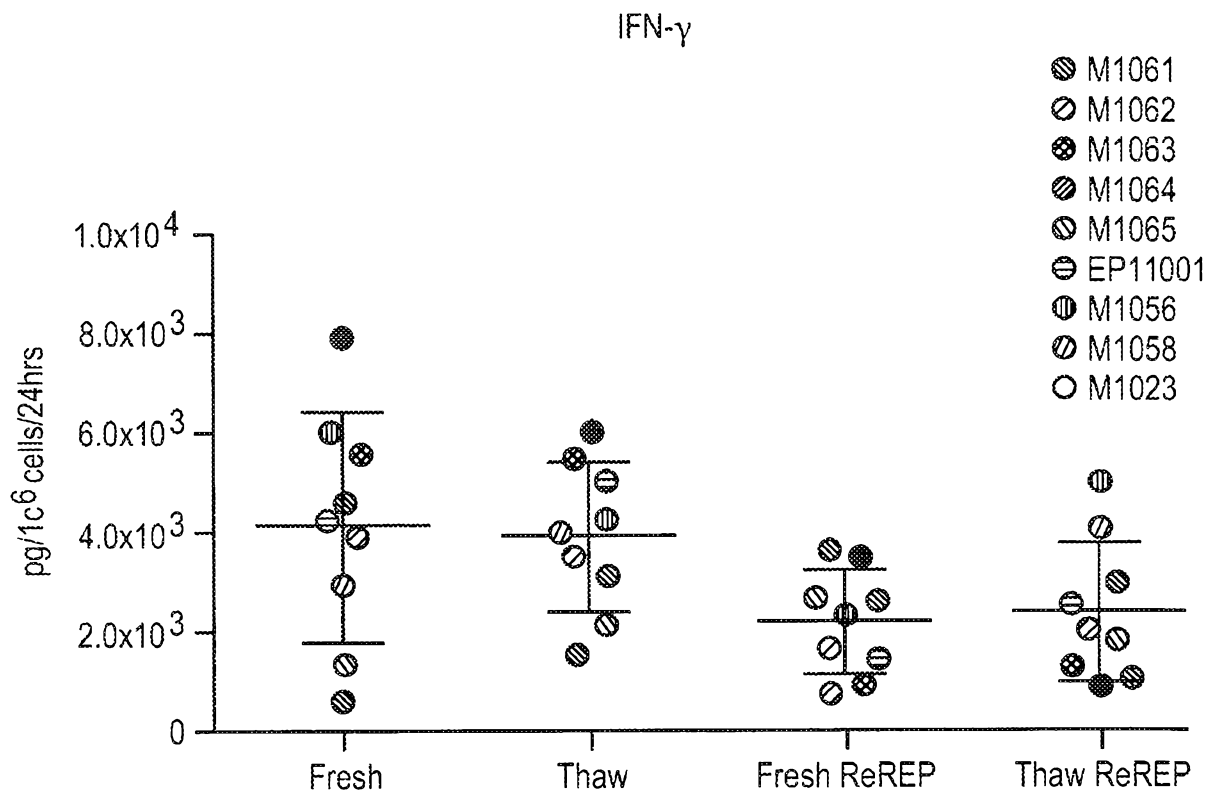

Figure 35

Granzyme B

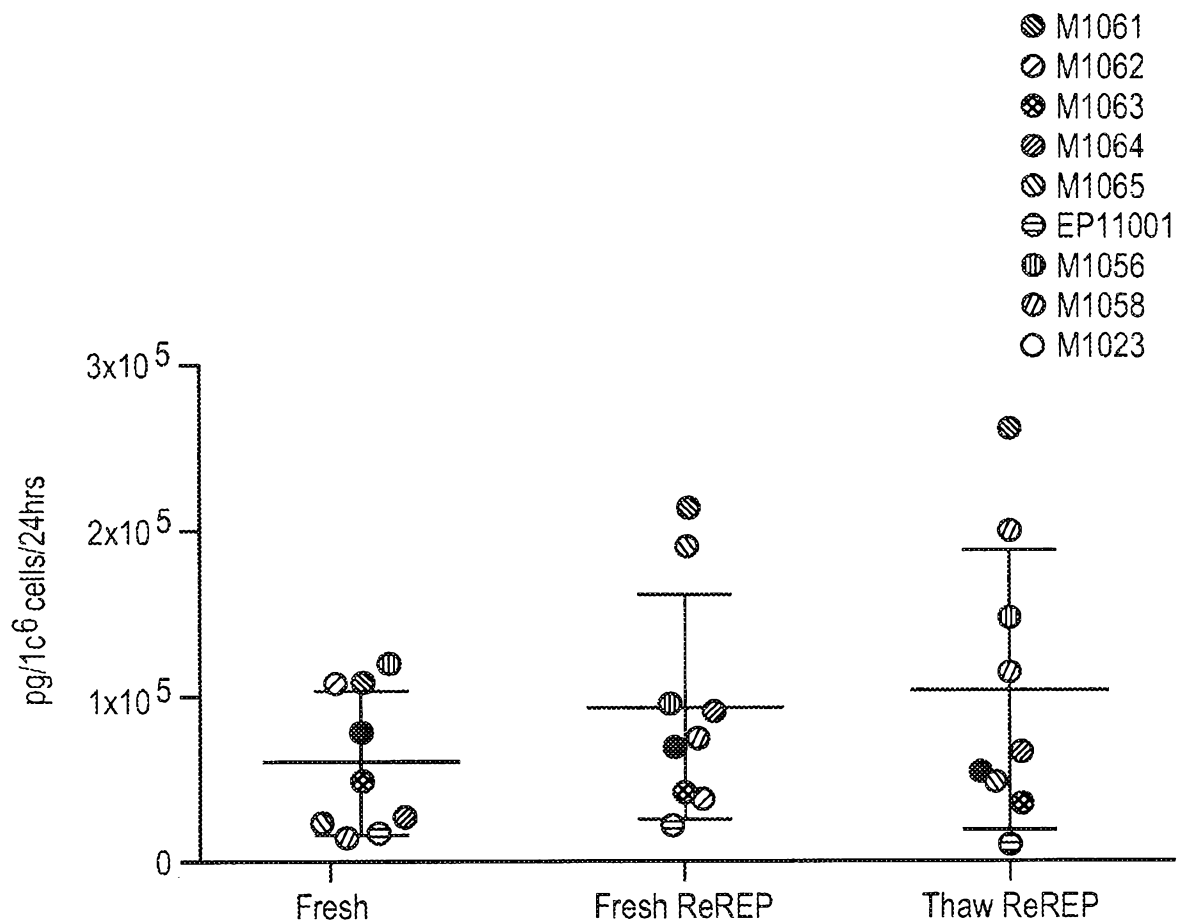

Figure 36

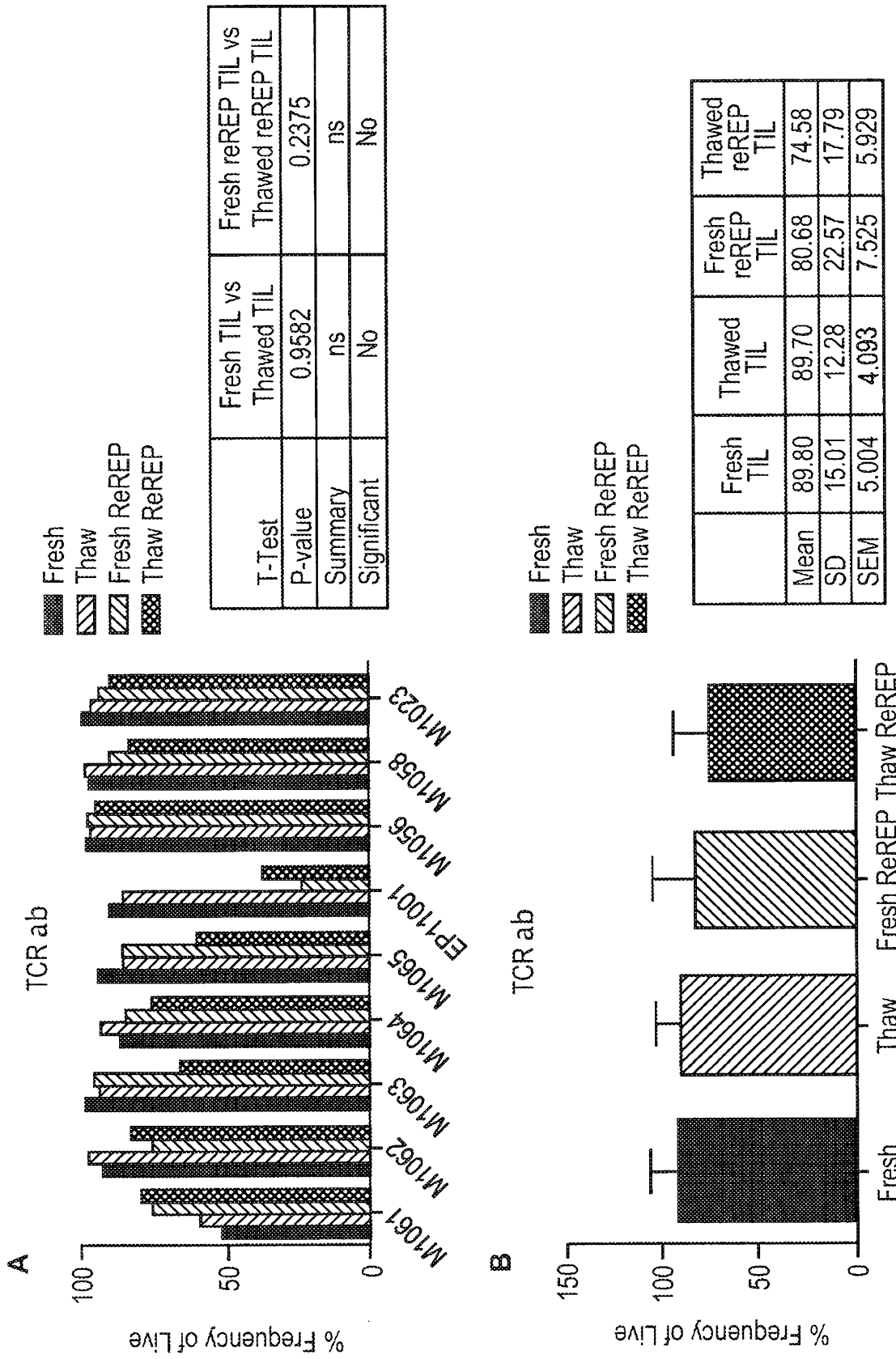

Figure 37

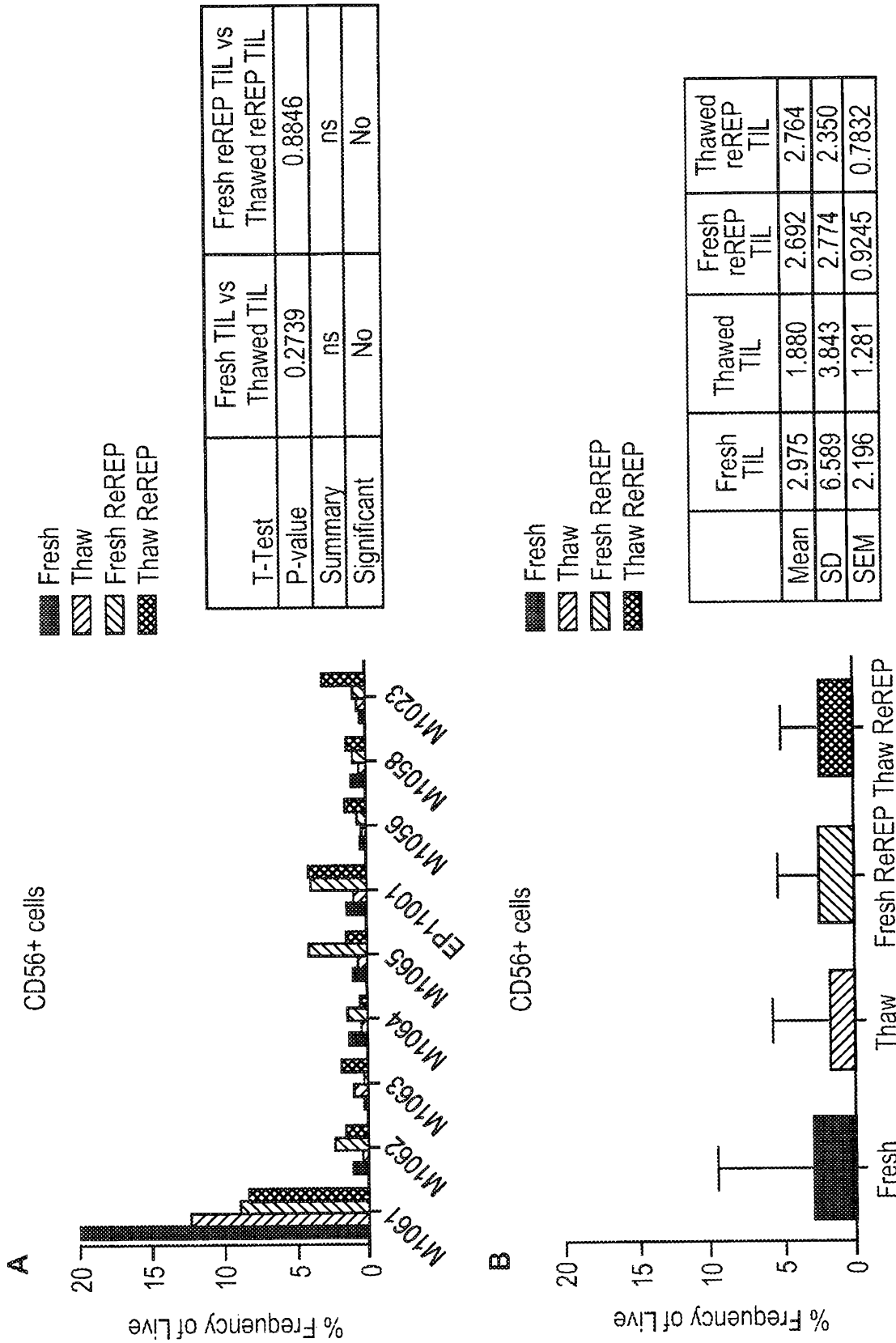

Figure 38

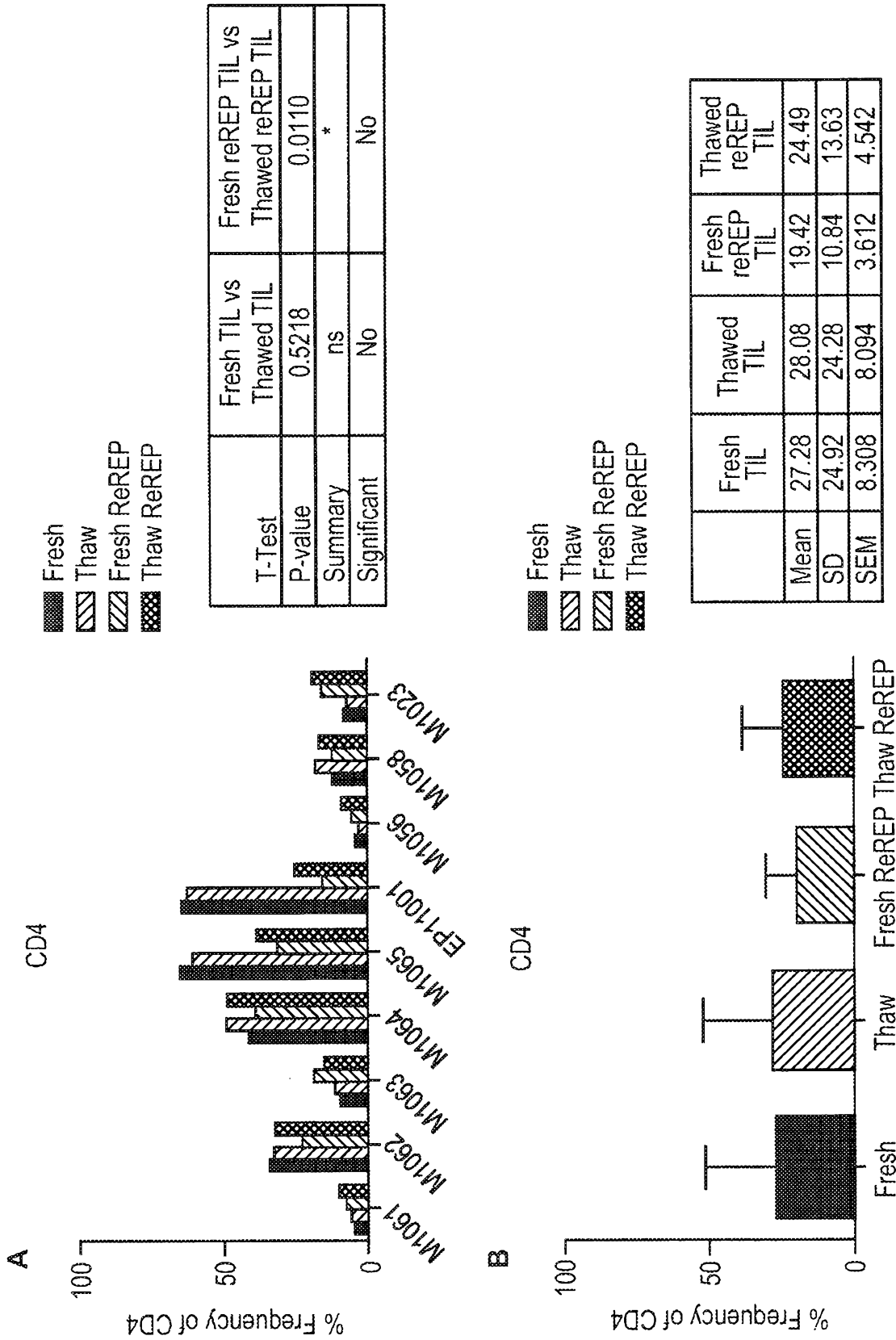

Figure 39

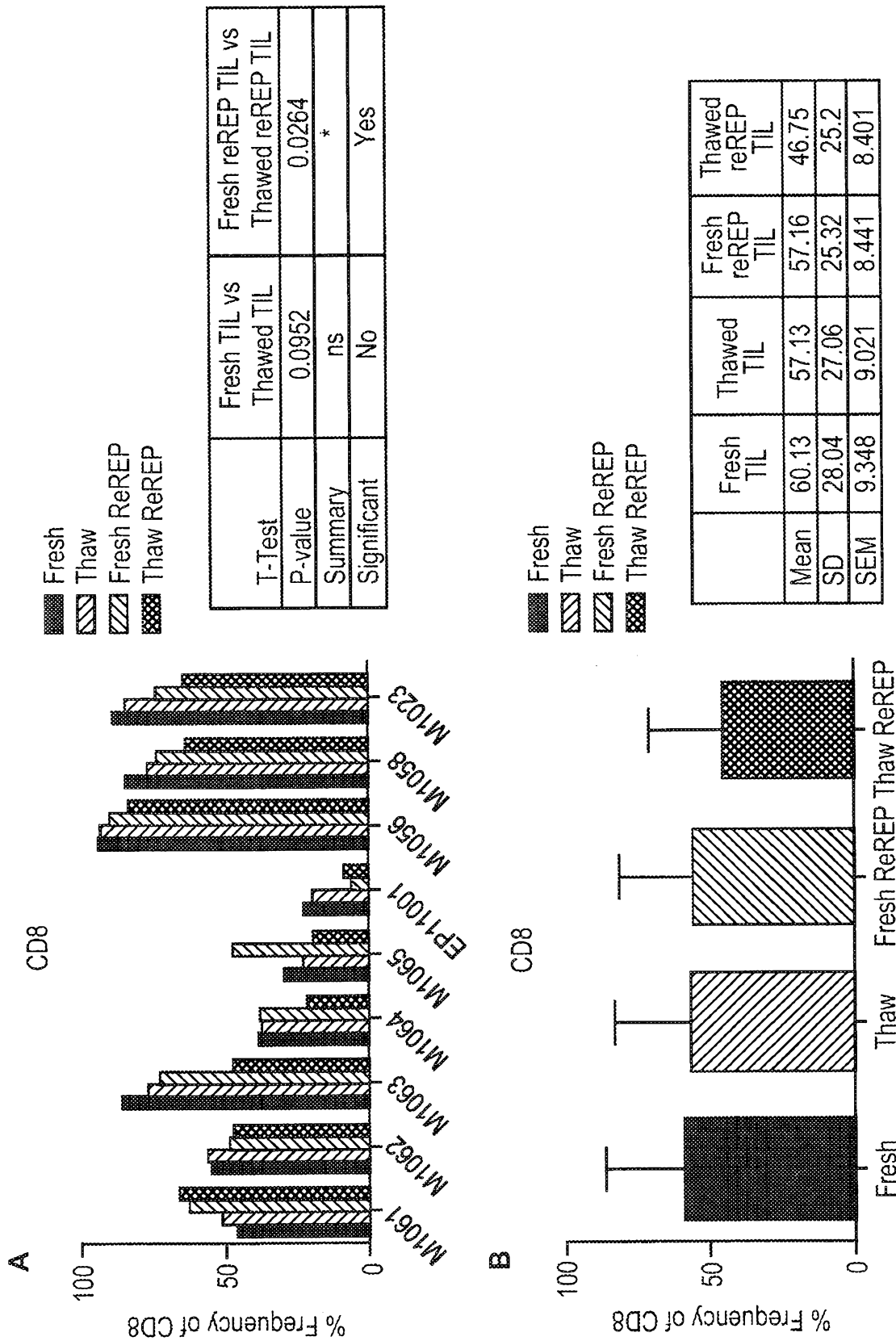

Figure 40

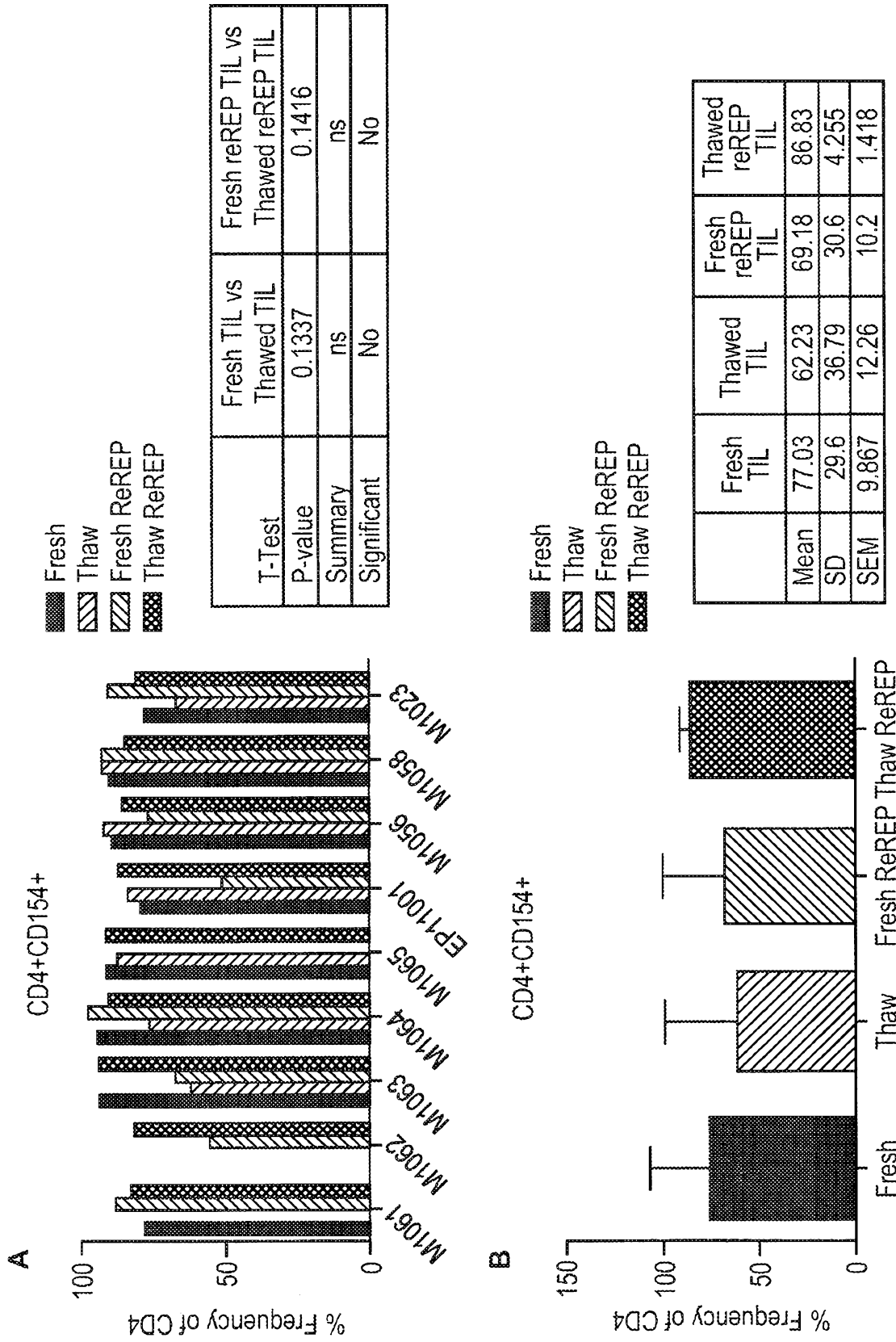

Figure 41

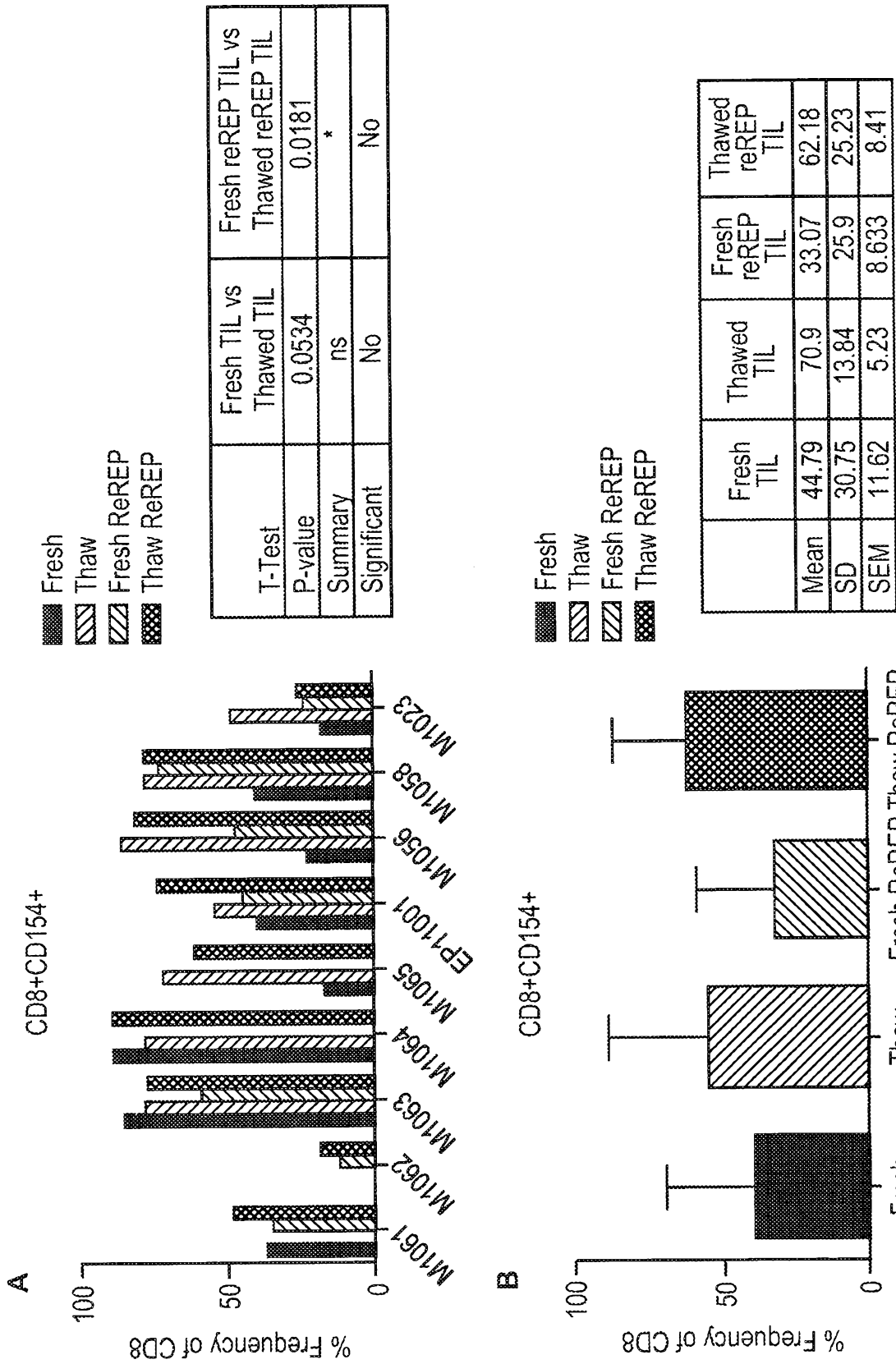

Figure 42

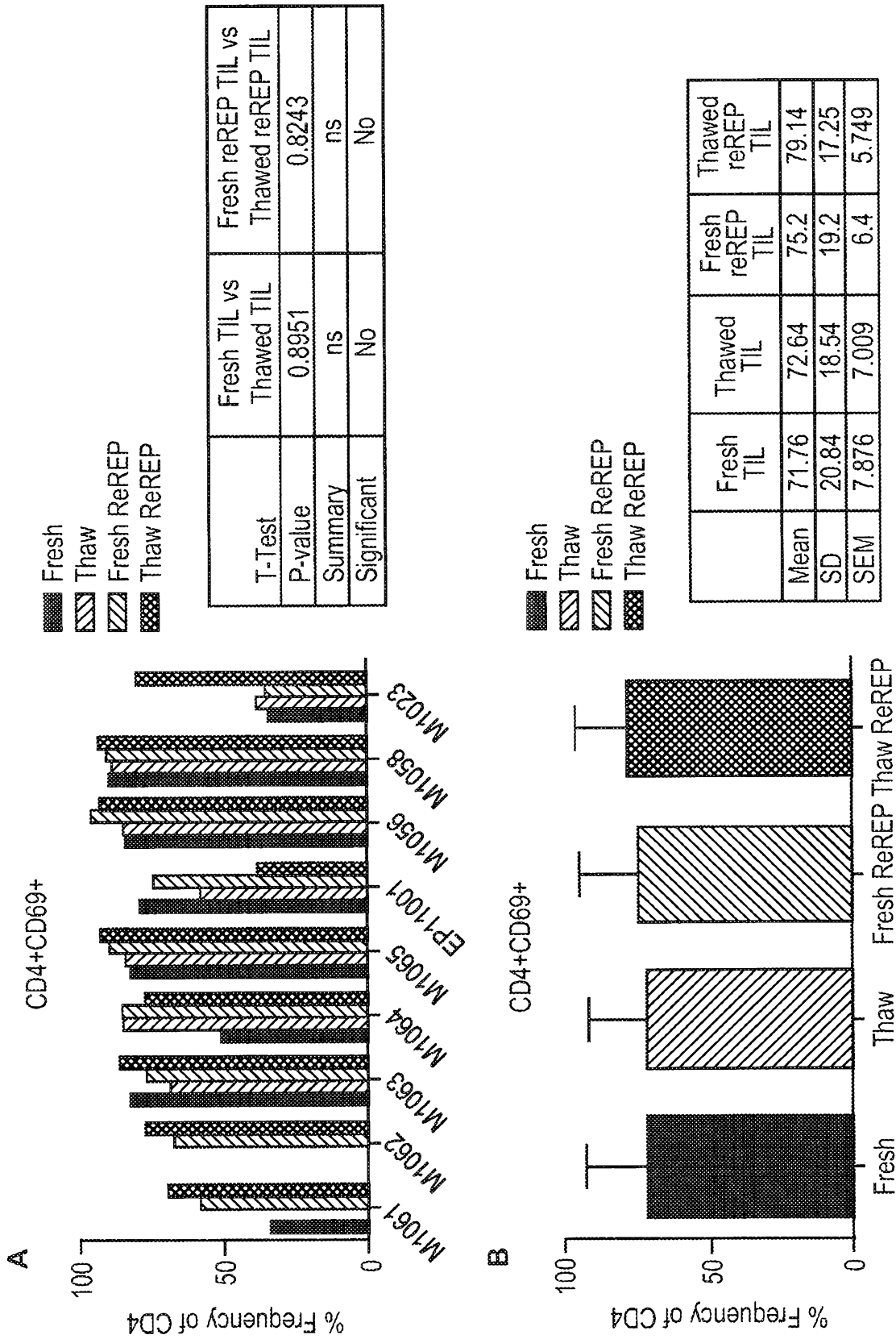

Figure 43

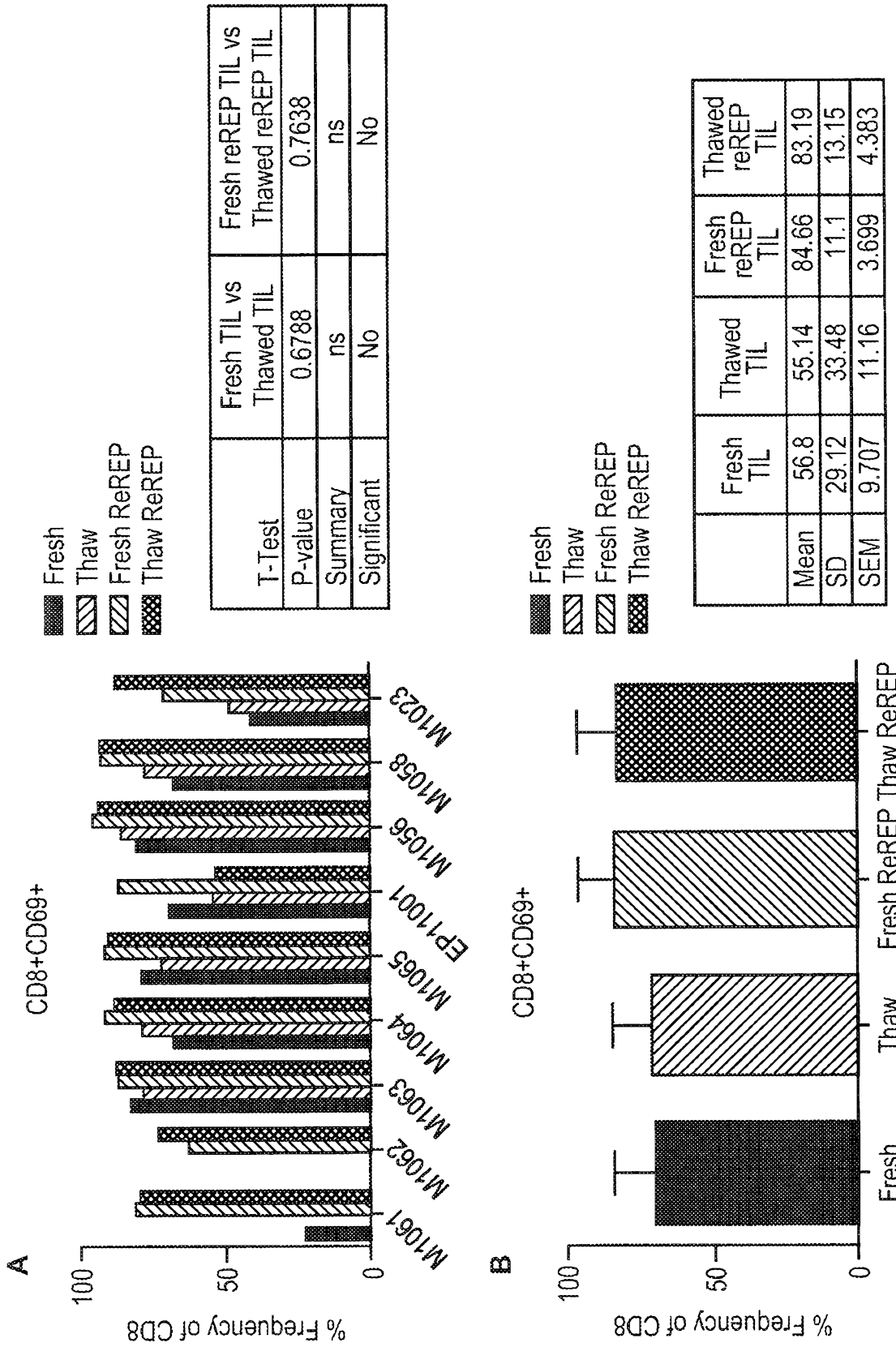

Figure 44

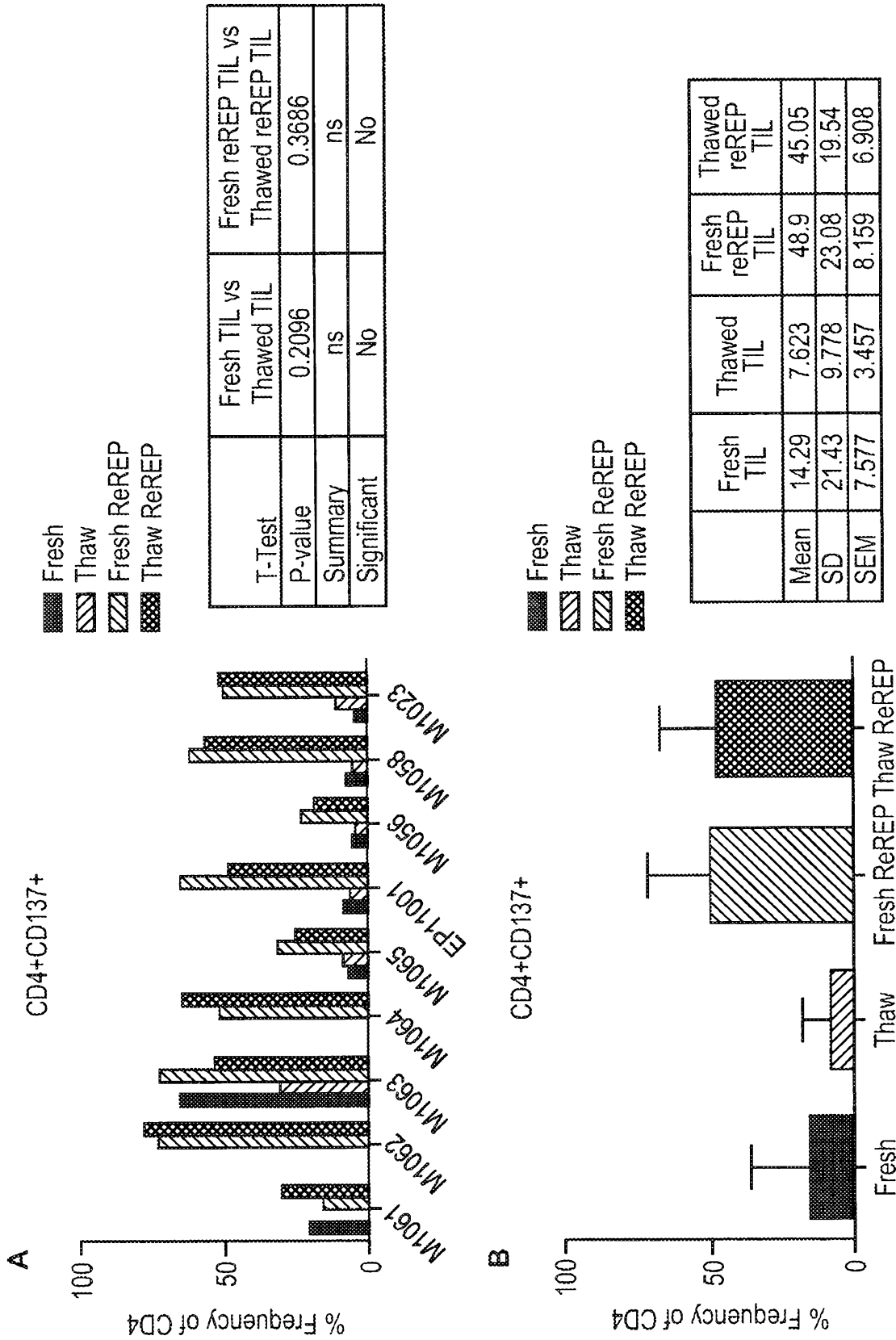

Figure 45

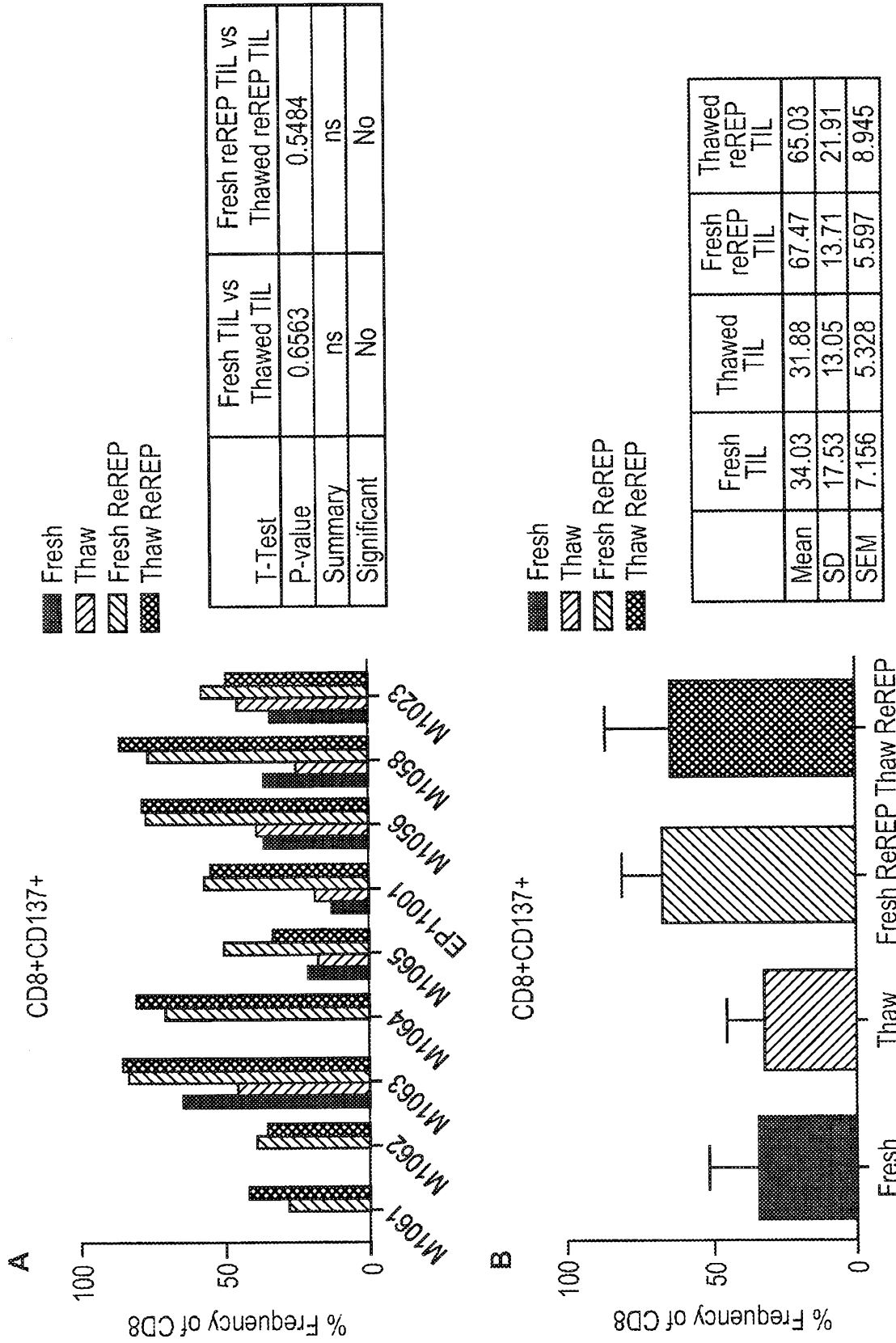

Figure 46



Figure 47

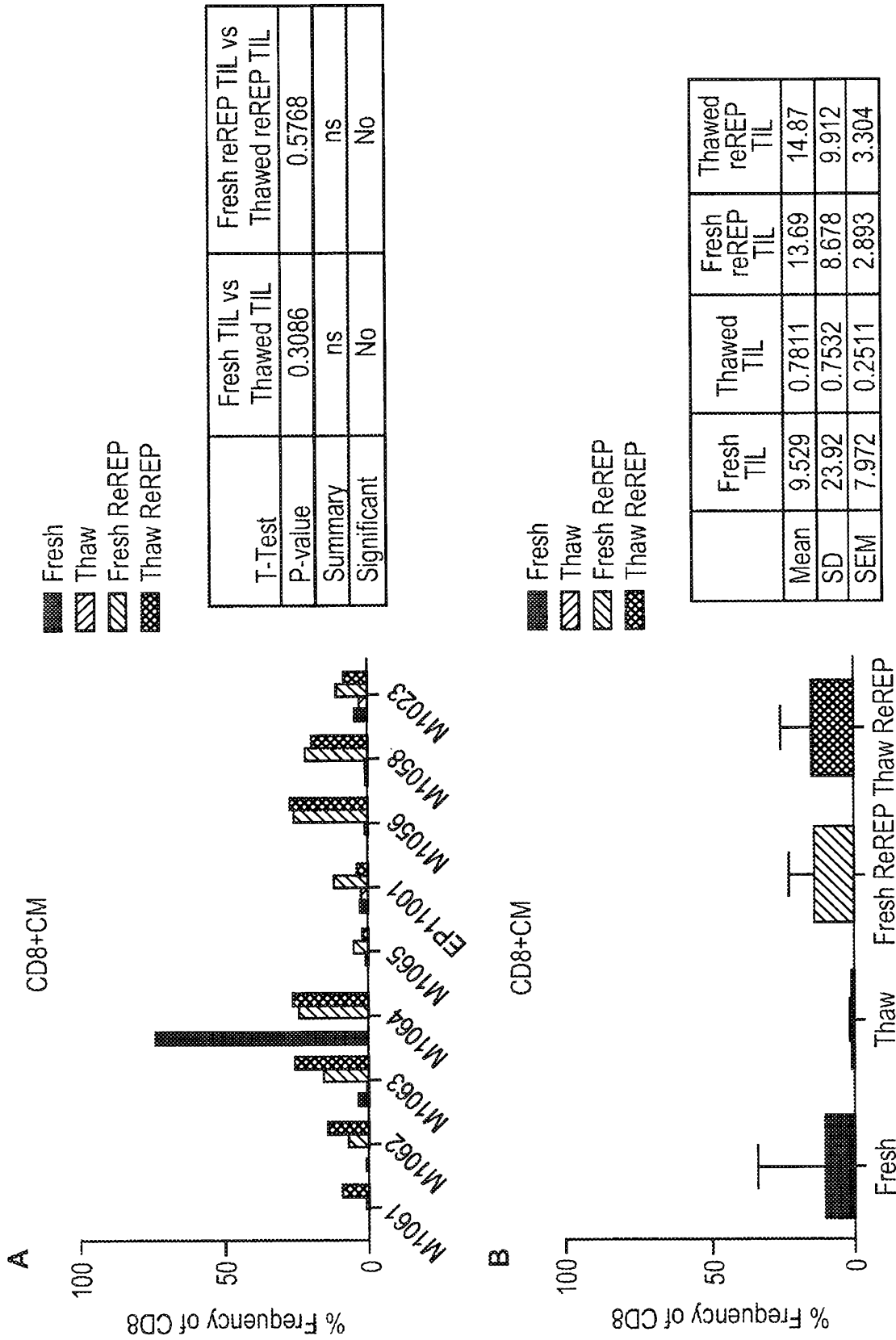

Figure 48

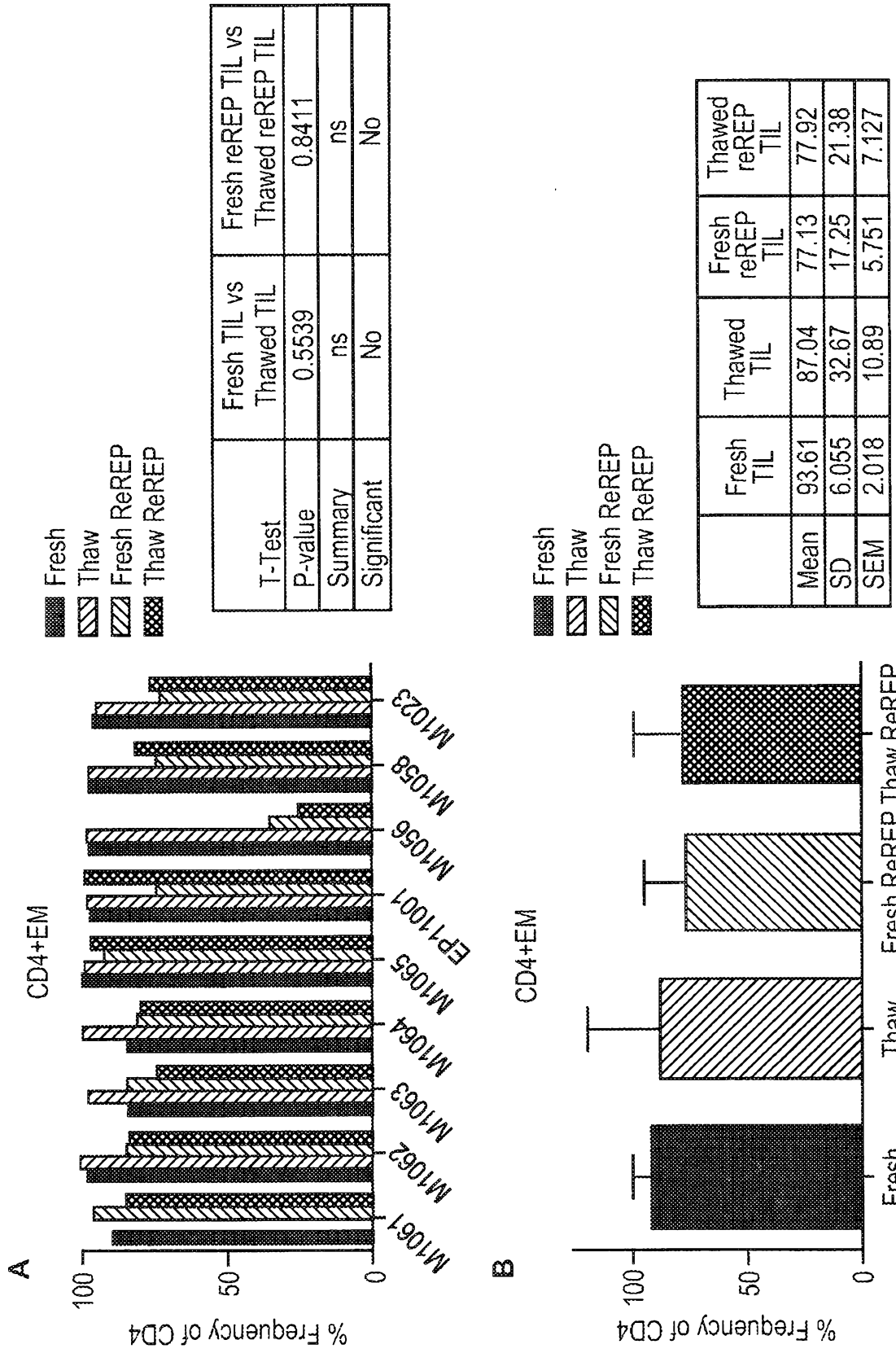

Figure 49

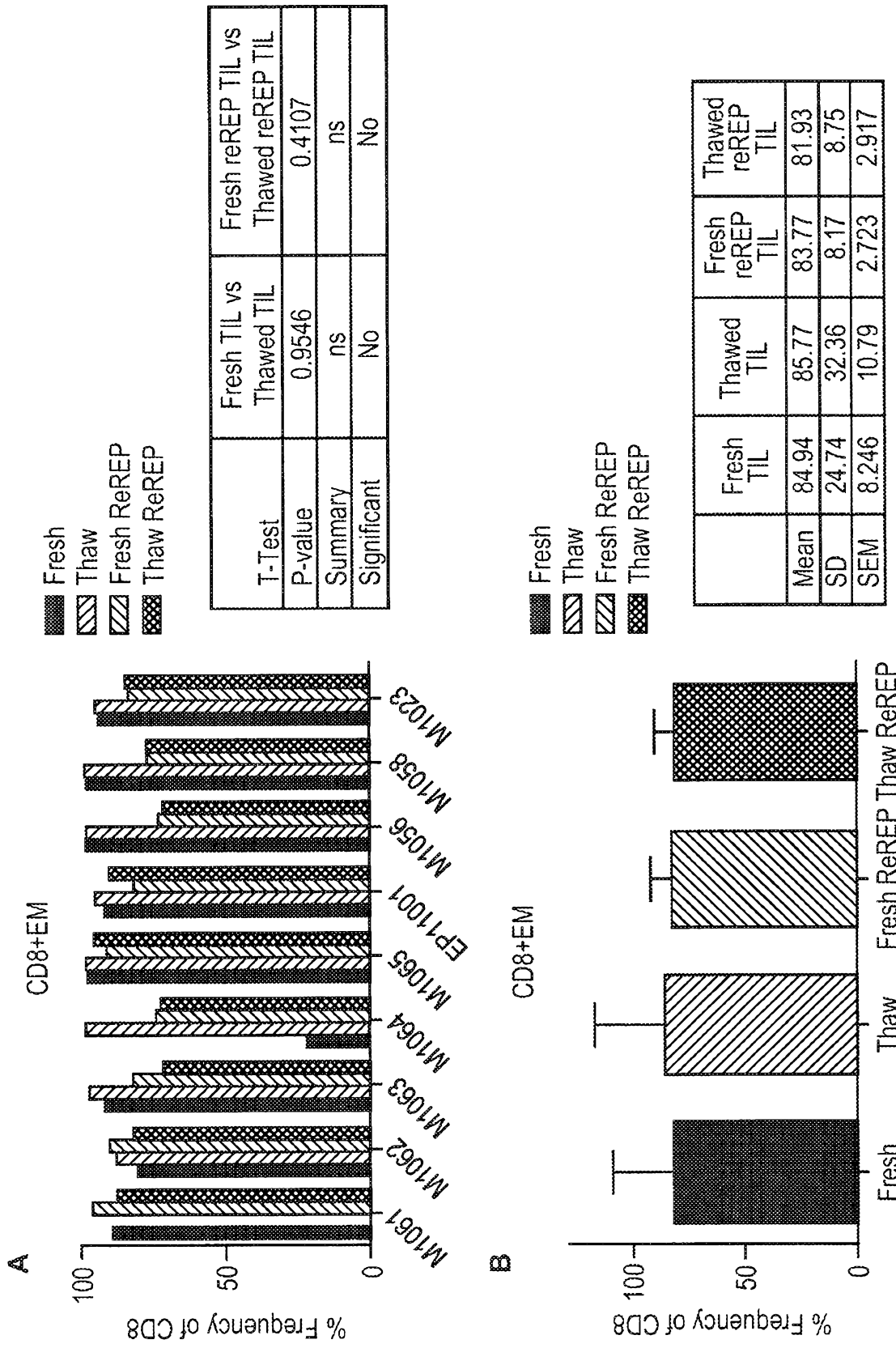

Figure 50

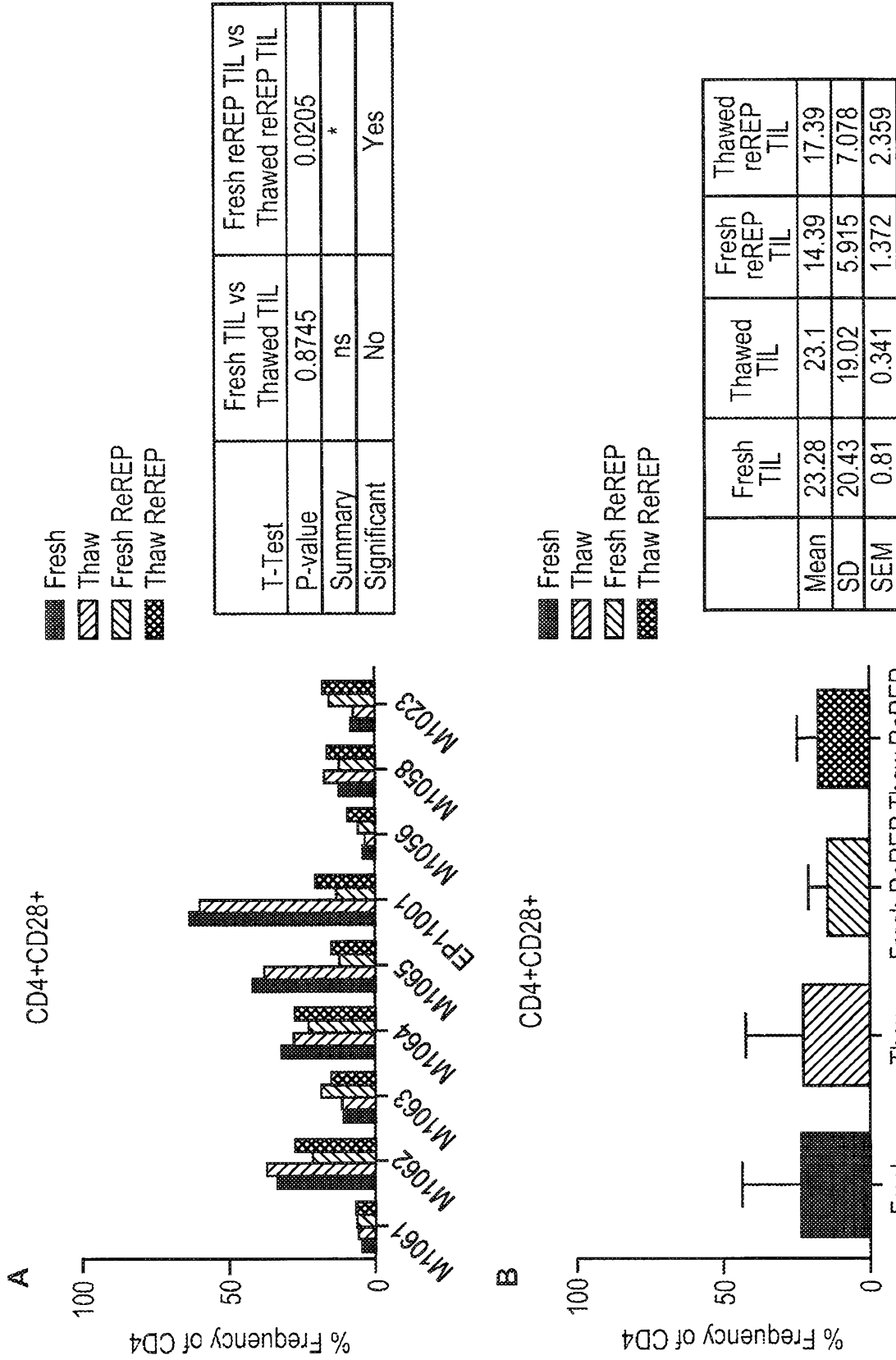

Figure 51

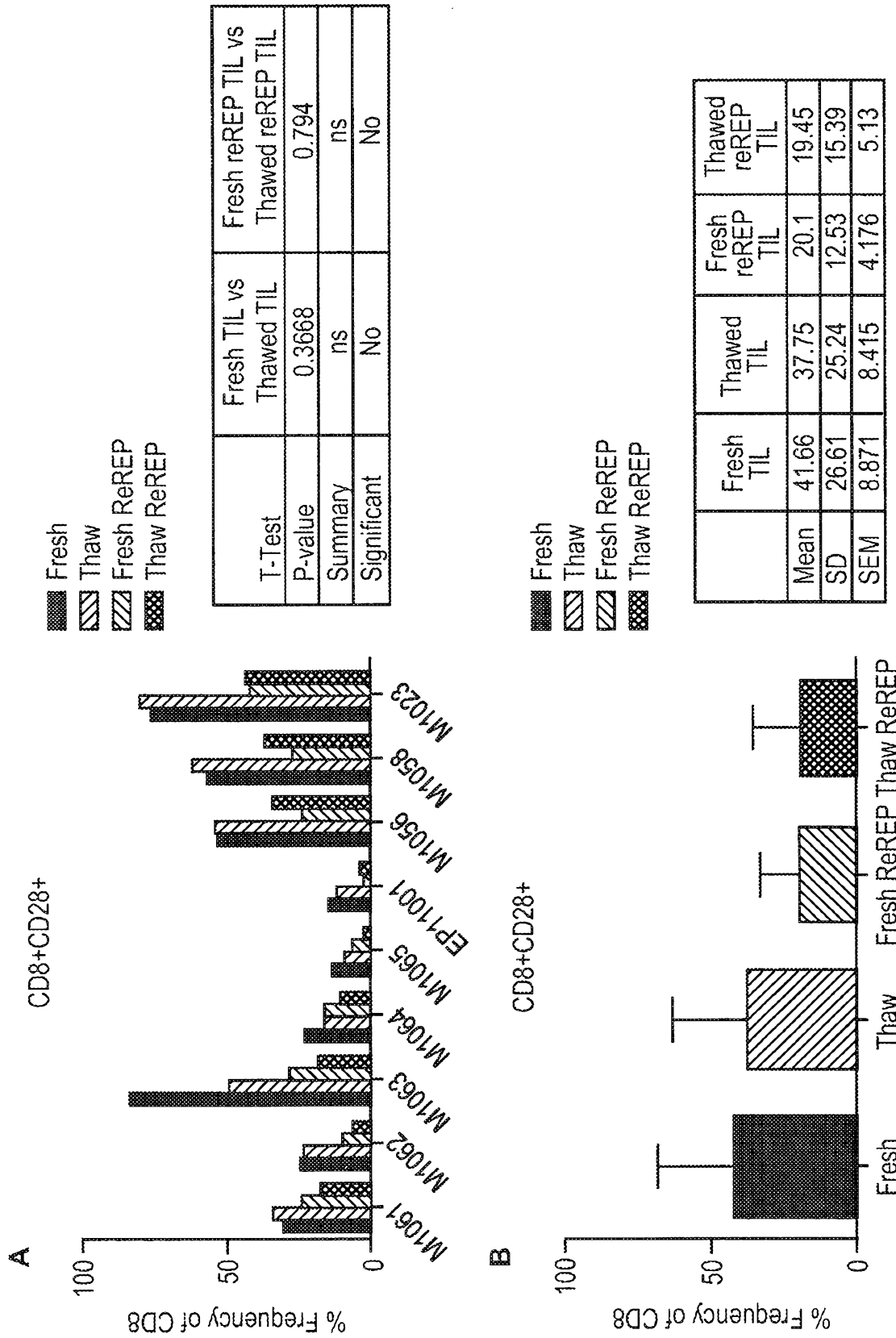

Figure 52

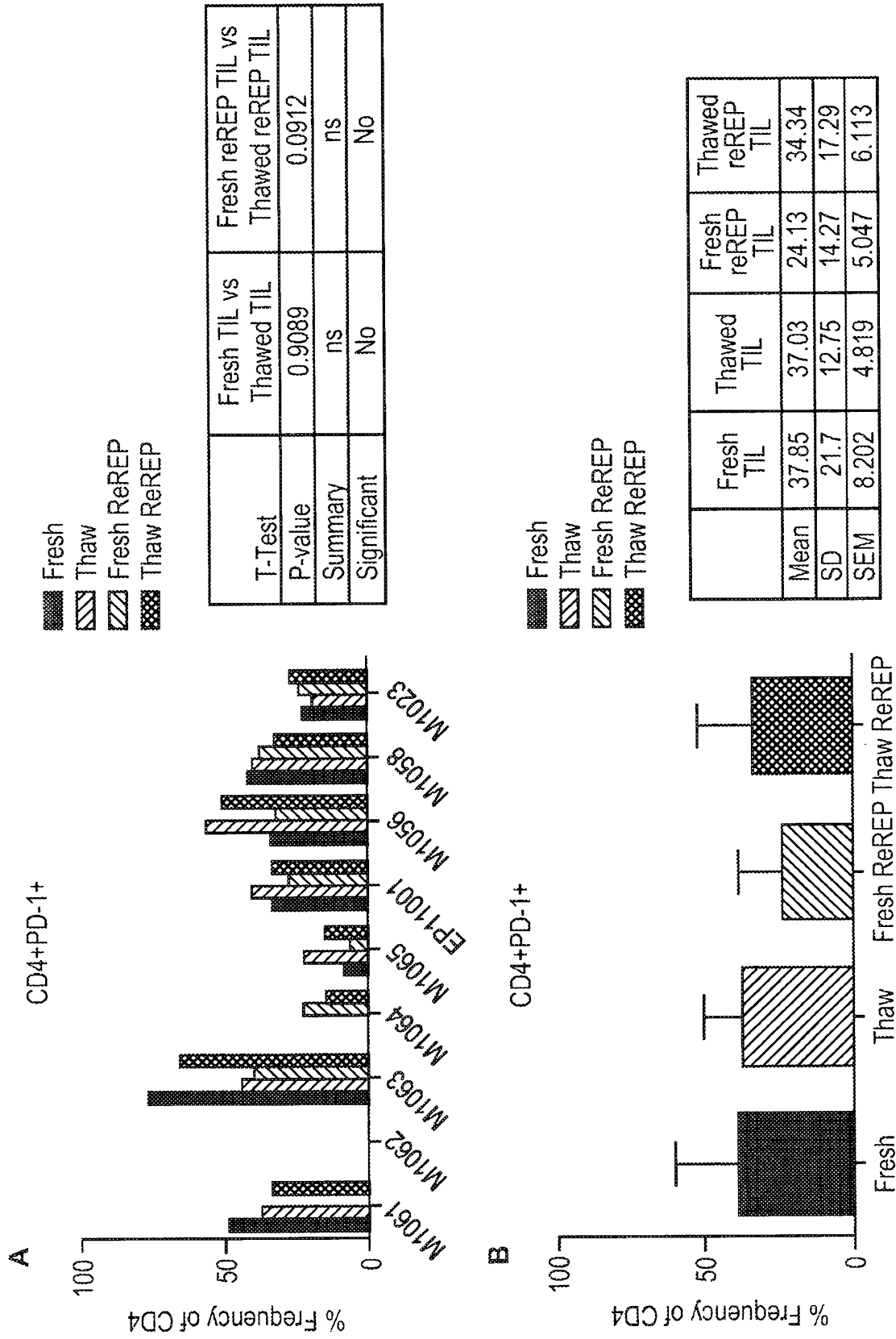

Figure 53

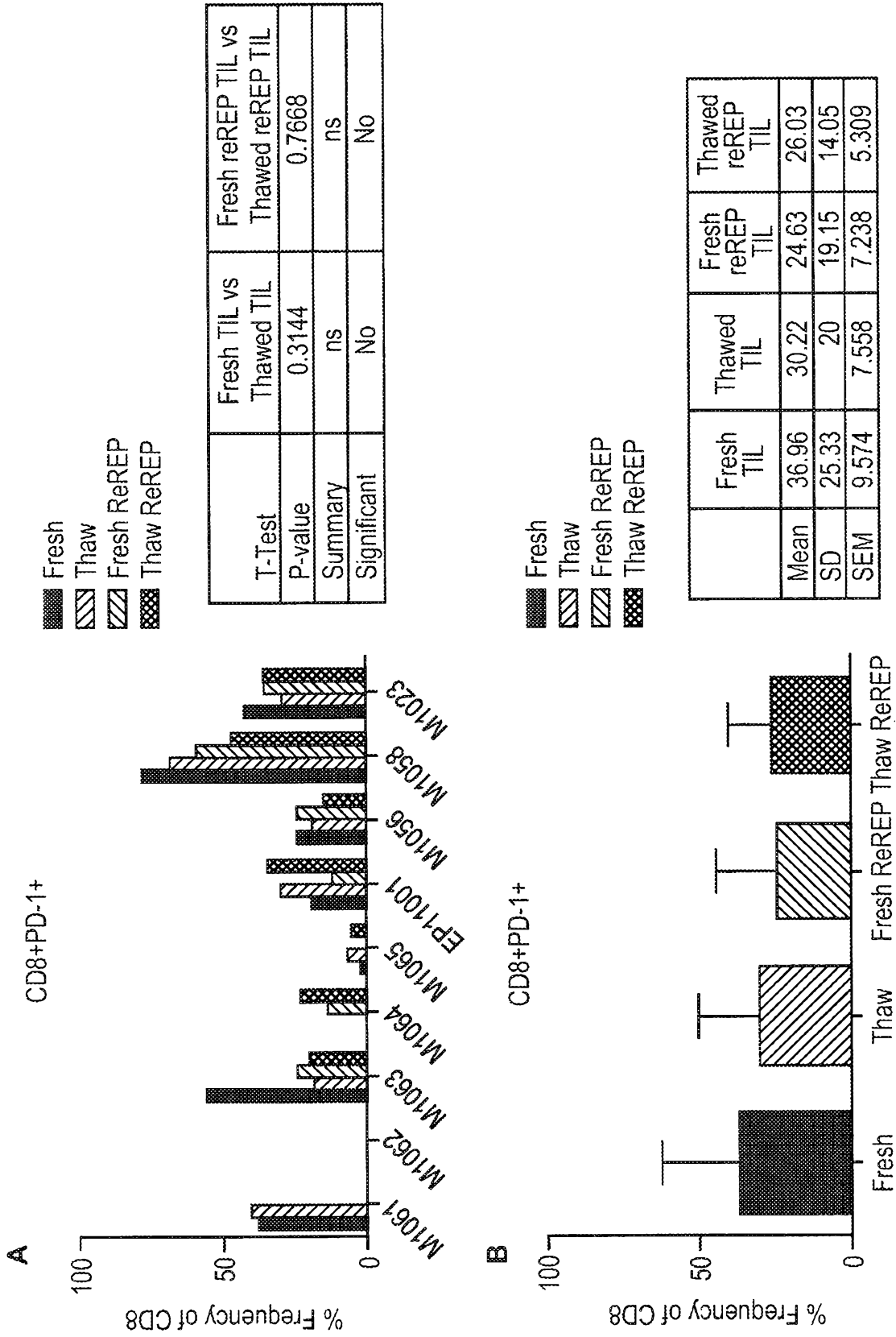

Figure 54

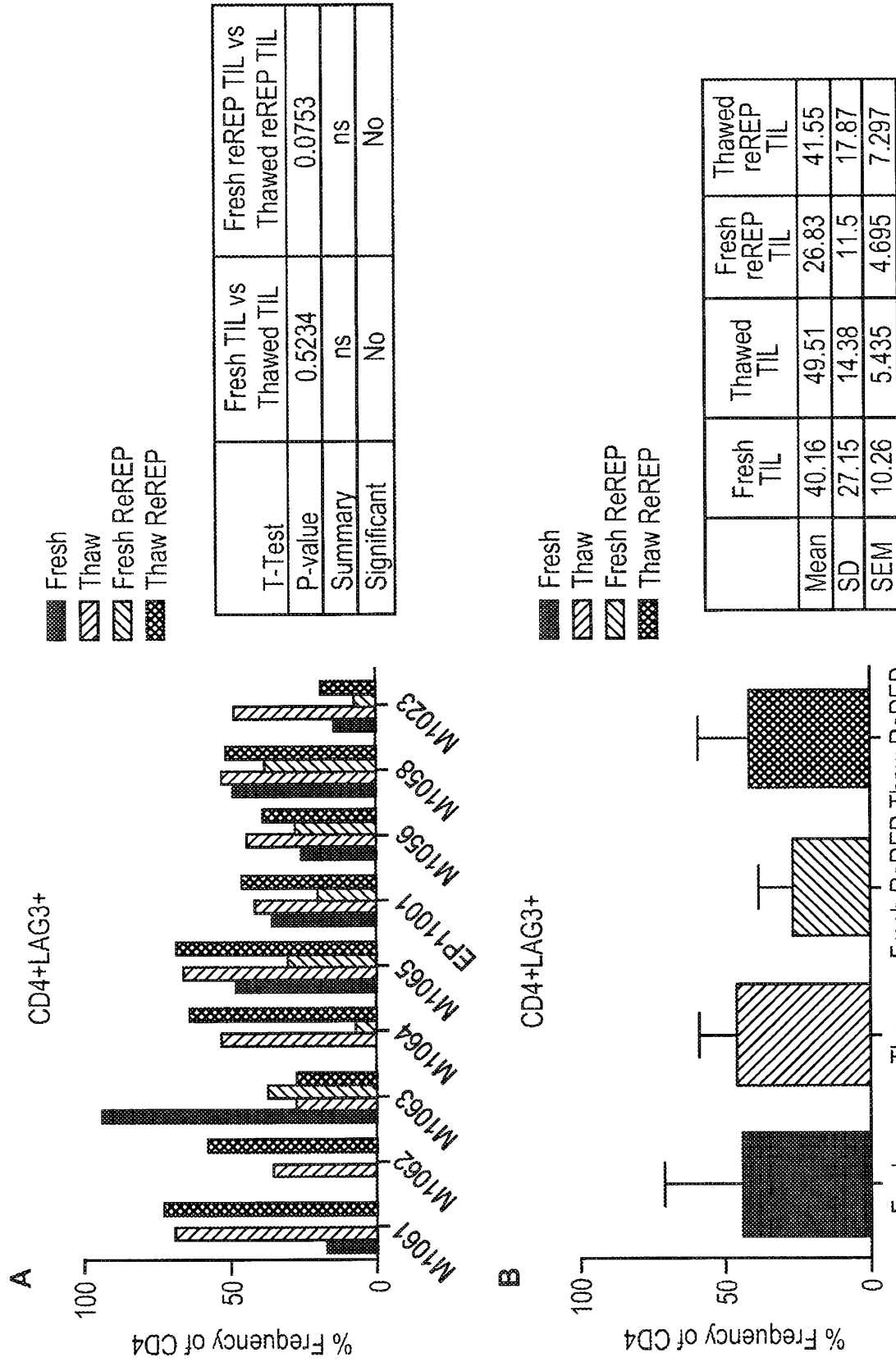

Figure 55

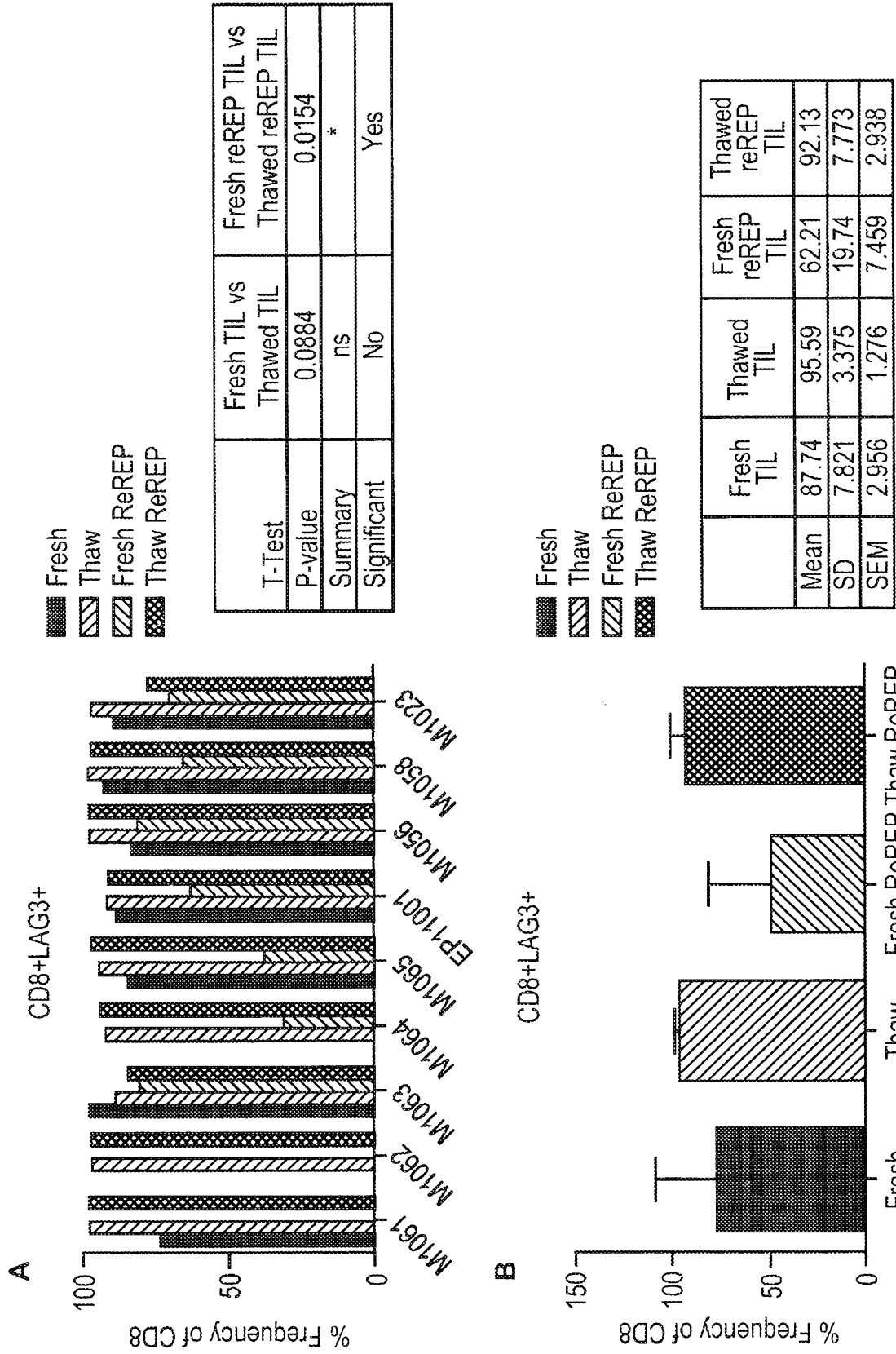

Figure 56

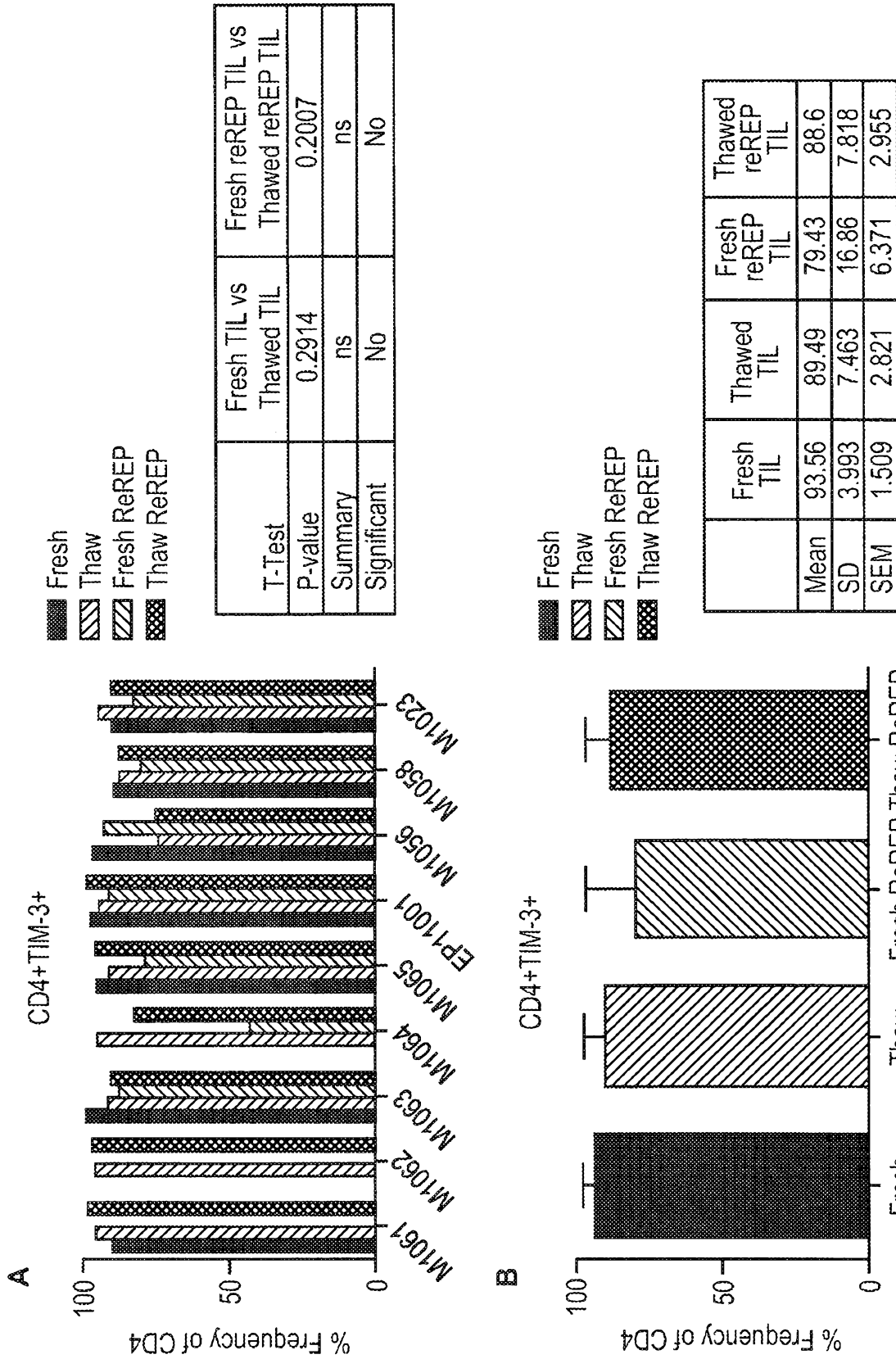

Figure 57

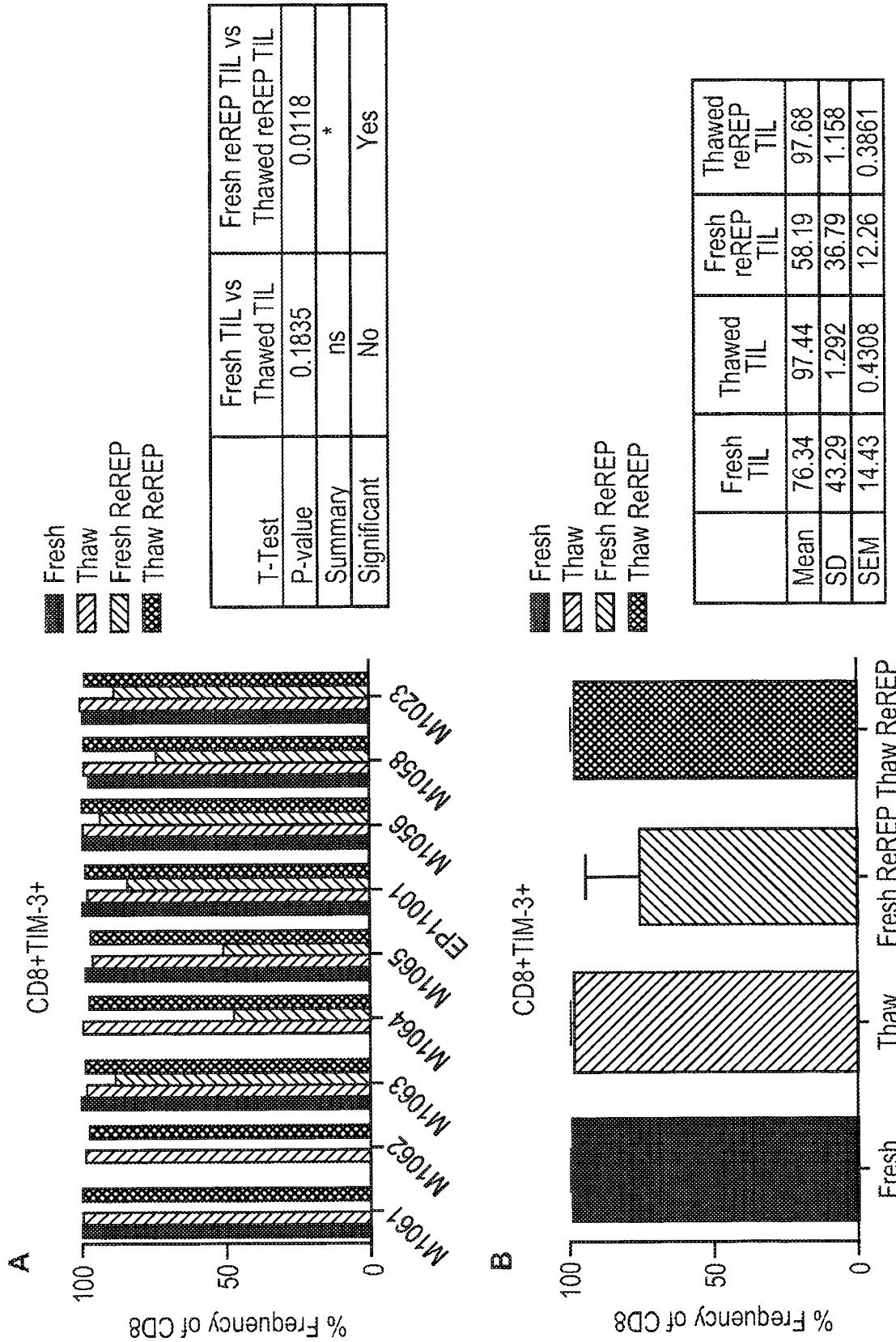

Figure 58

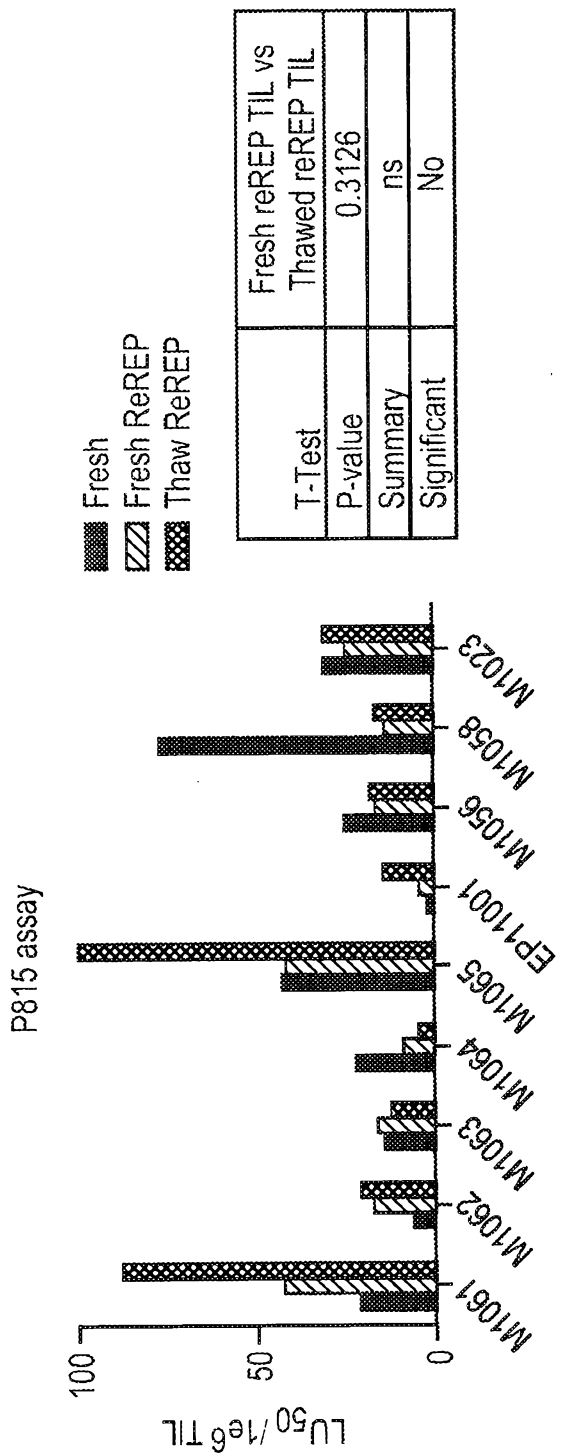

Figure 59

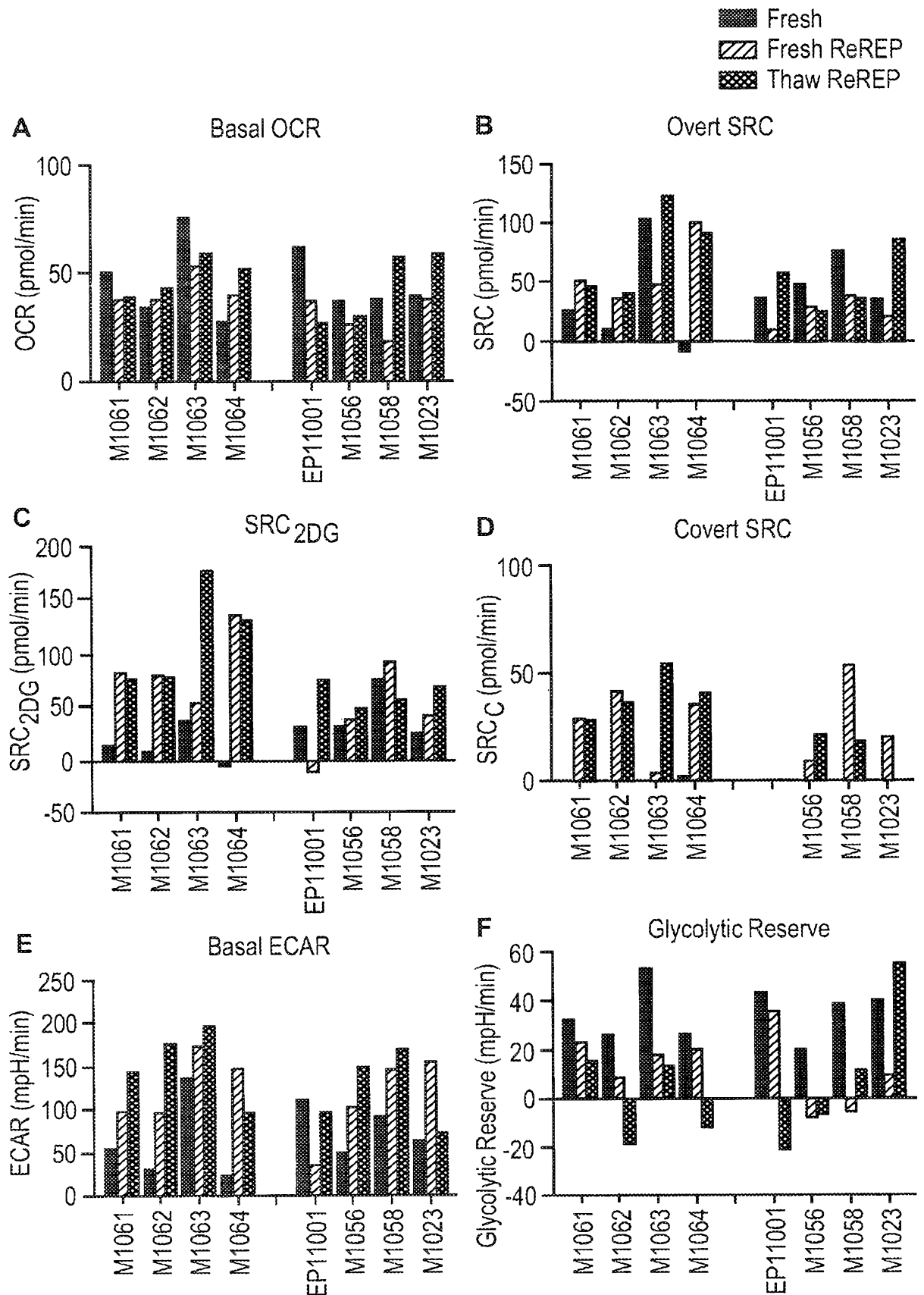

Figure 60

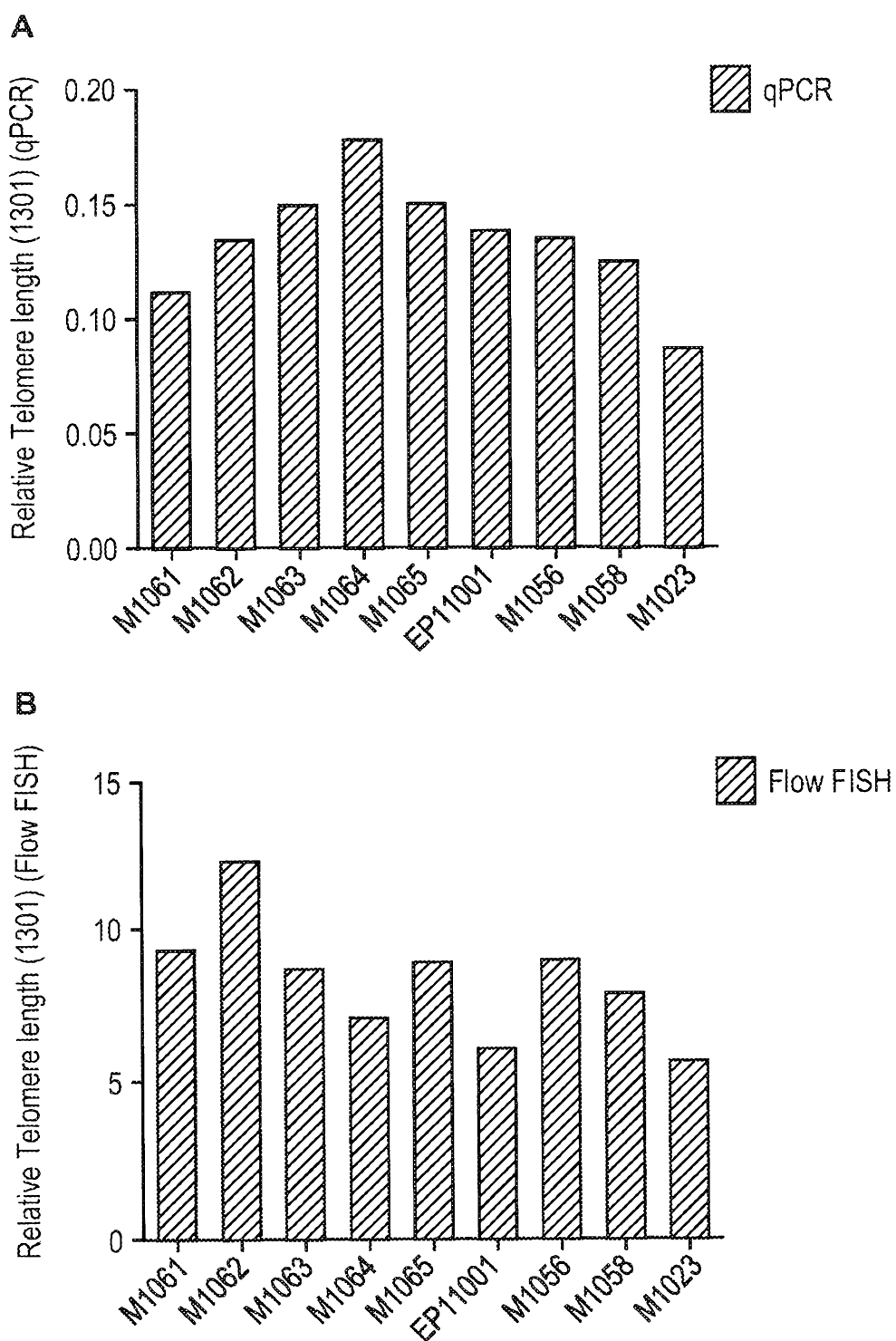
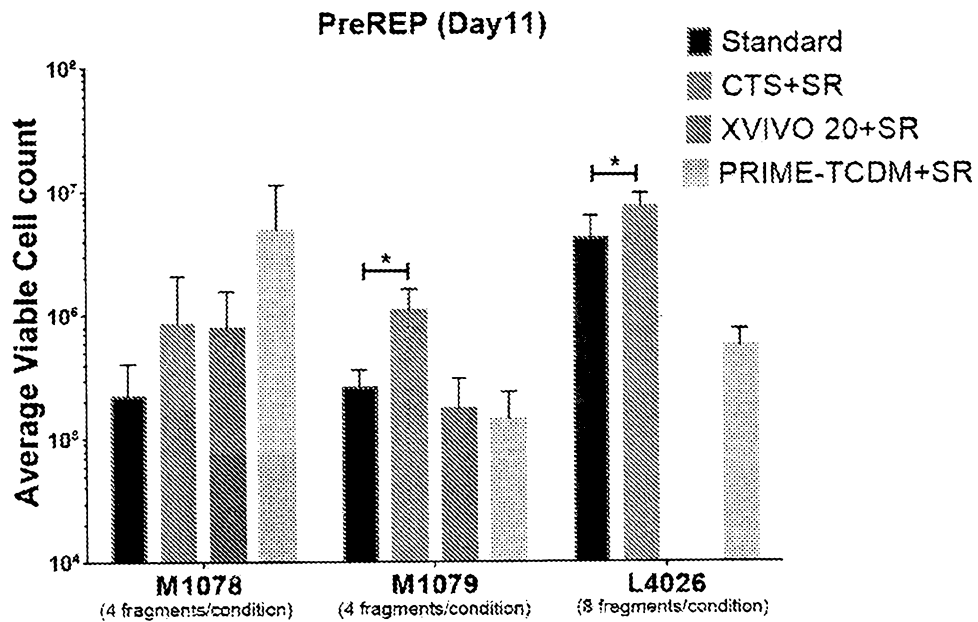

Figure 61

67/136

Figure 62

A)



B)

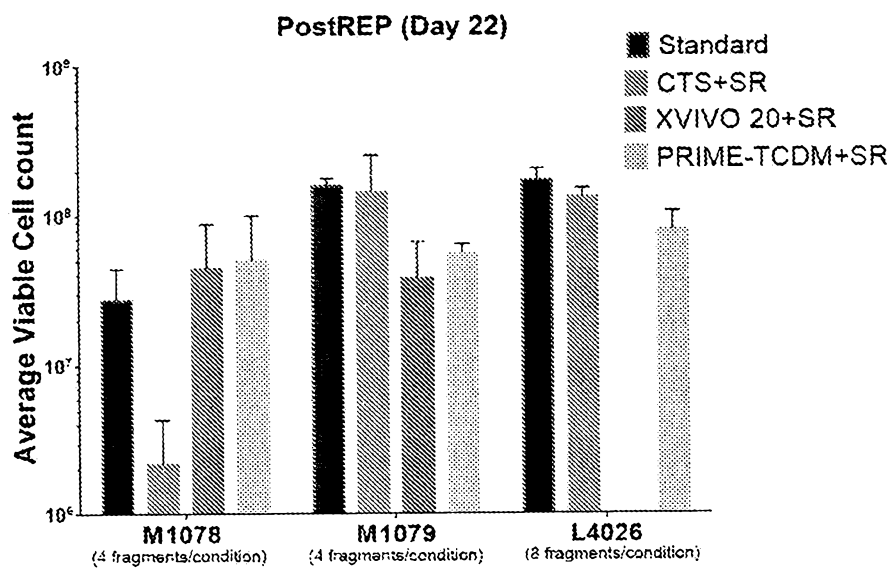
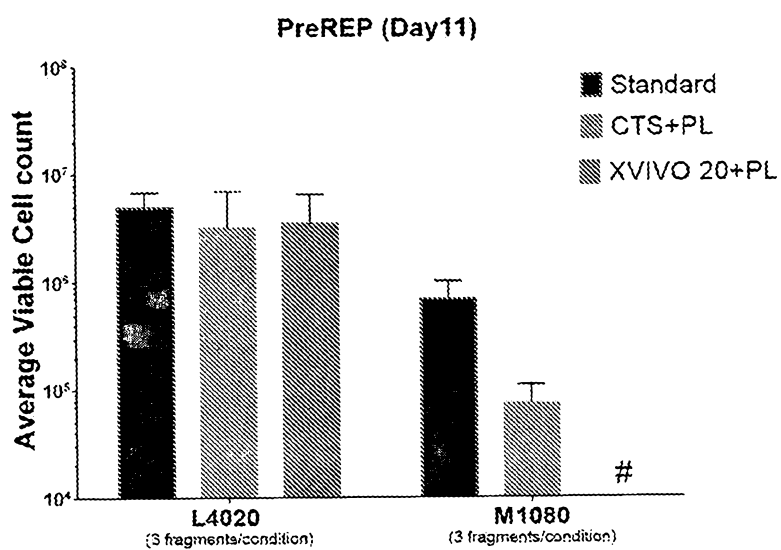

Figure 63

A)



B)

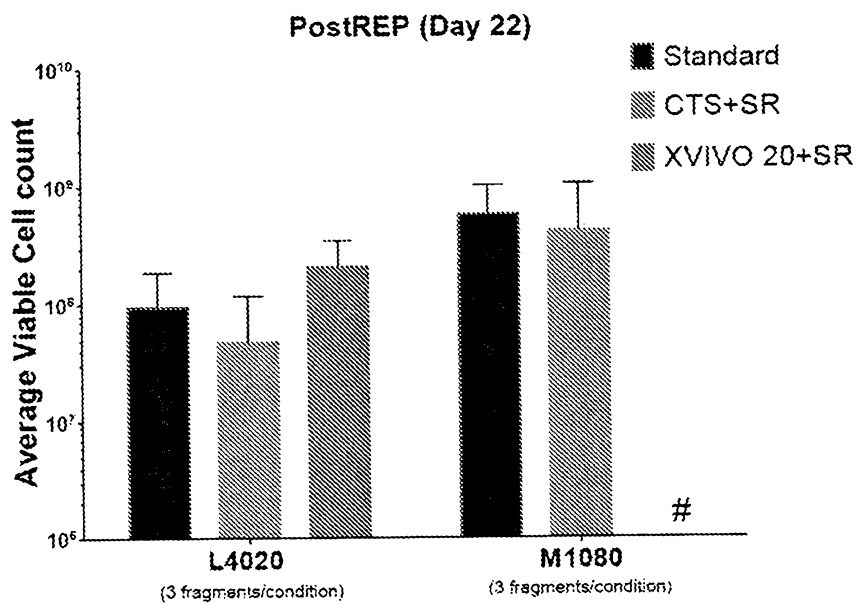

Figure 64A

A)

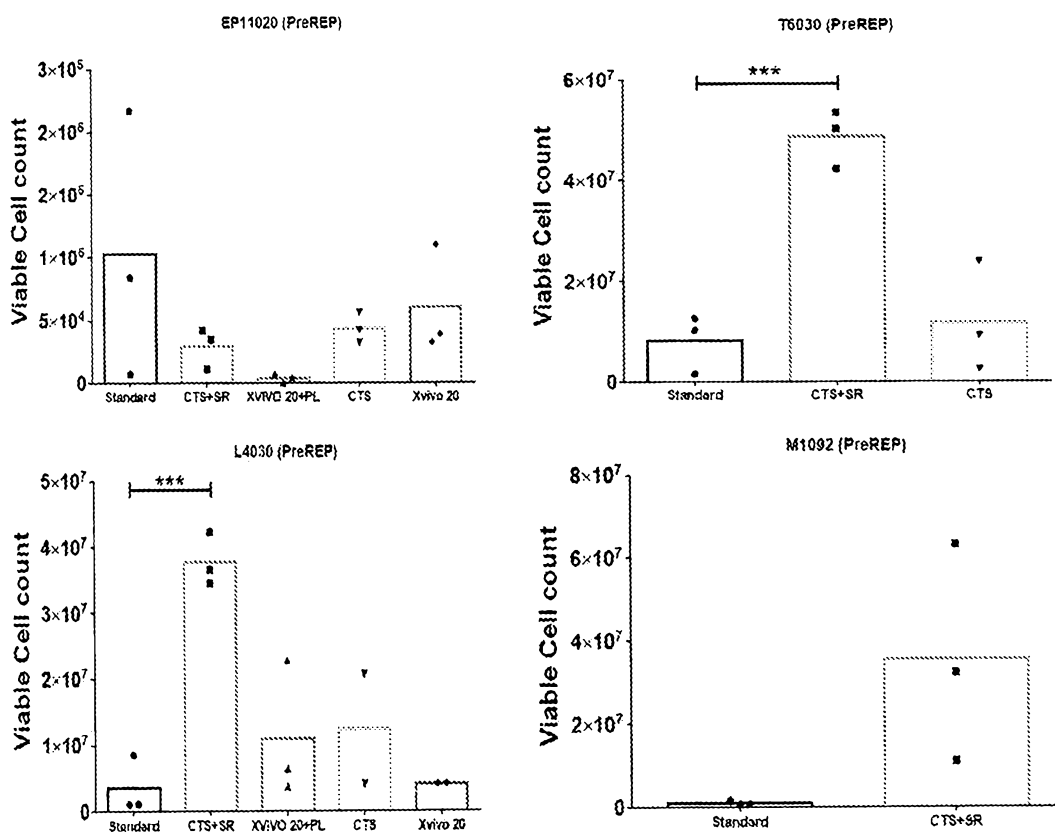
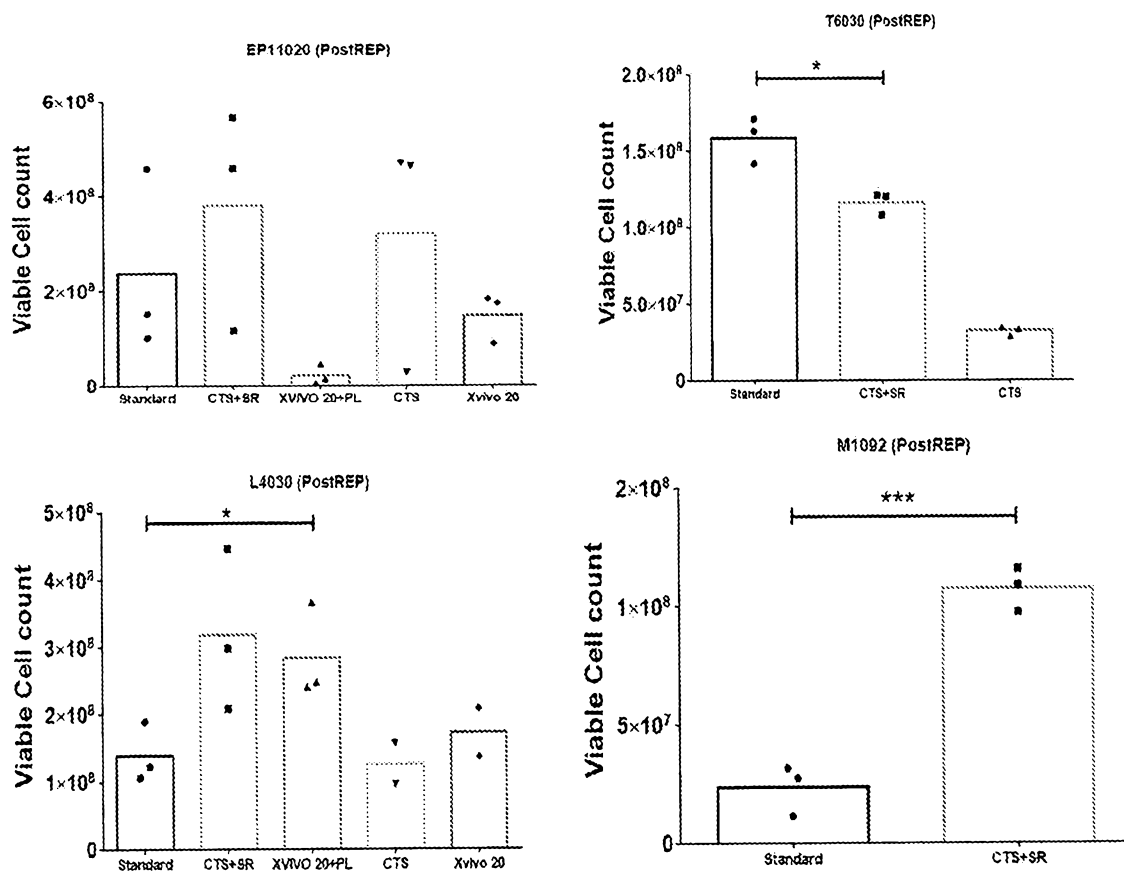

Figure 64B

B)



71/136

Figure 65A &amp; 65B

A)

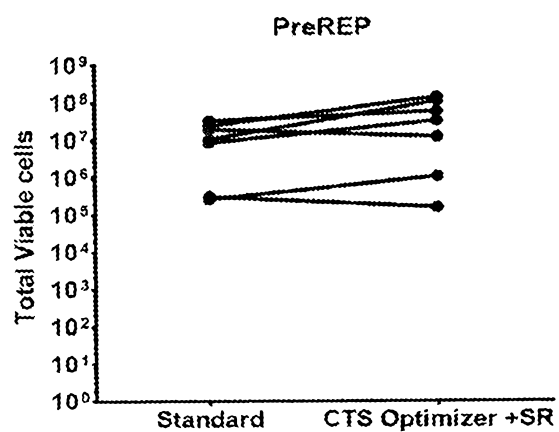

B)

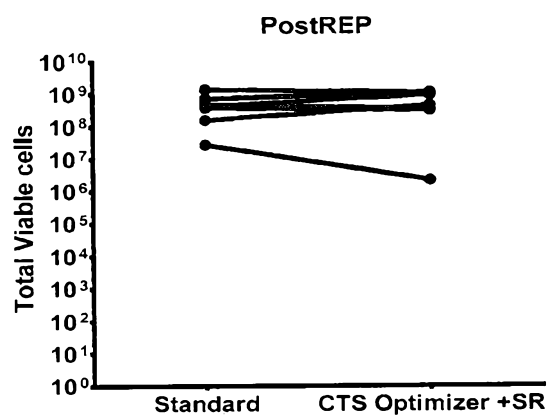

Figure 65C

C)

	Pre-REP Cell count		Post-REP Cell count	
	Standard	CTS Optimizer +SR	Standard	CTS Optimizer +SR
M1078	8.82E+07	3.38E+08	3.46E+09	2.73E+08
M1079	2.60E+06	1.09E+07	1.99E+10	5.61E+10
M1080				
L4020	1.98E+08	1.27E+08	4.75E+10	3.99E+10
L4026	1.68E+08	3.02E+08	8.63E+10	6.69E+10
L4030	7.05E+07	7.48E+08	2.63E+10	5.96E+10
EP11020	2.04E+06	1.06E+06	4.44E+10	7.14E+10
T6030	1.61E+08	9.64E+08	2.98E+10	2.18E+10
M1092	2.00E+07	7.05E+08	4.41E+09	2.02E+10

73/136

Figure 66

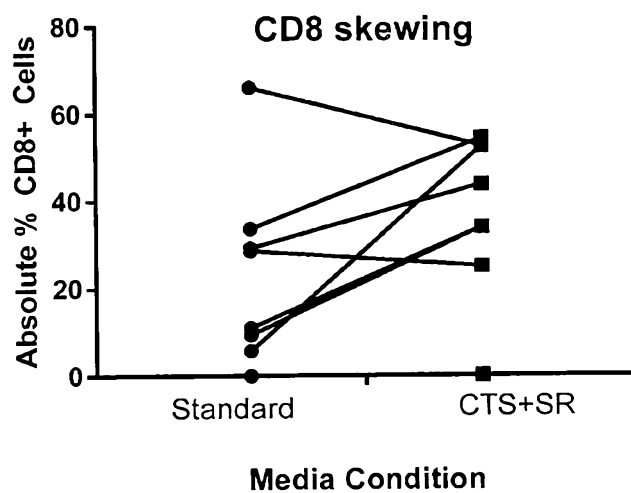

74/136

Figure 67

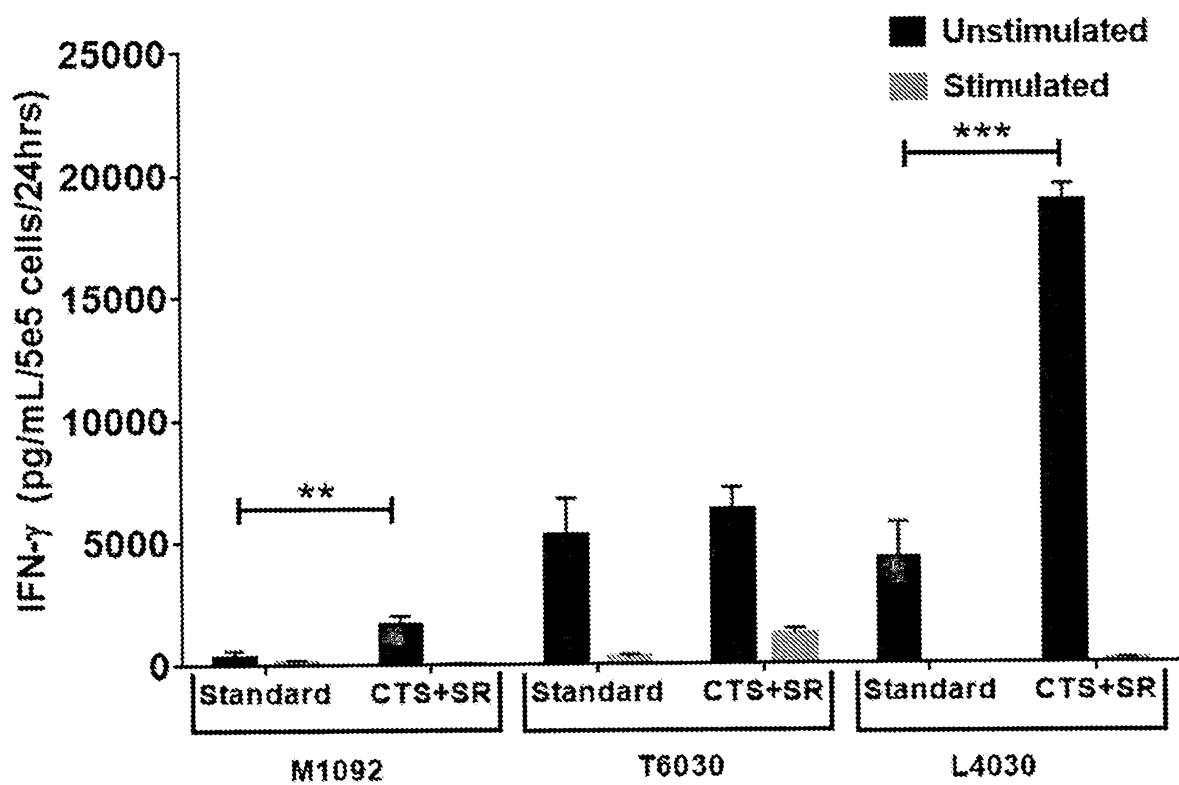

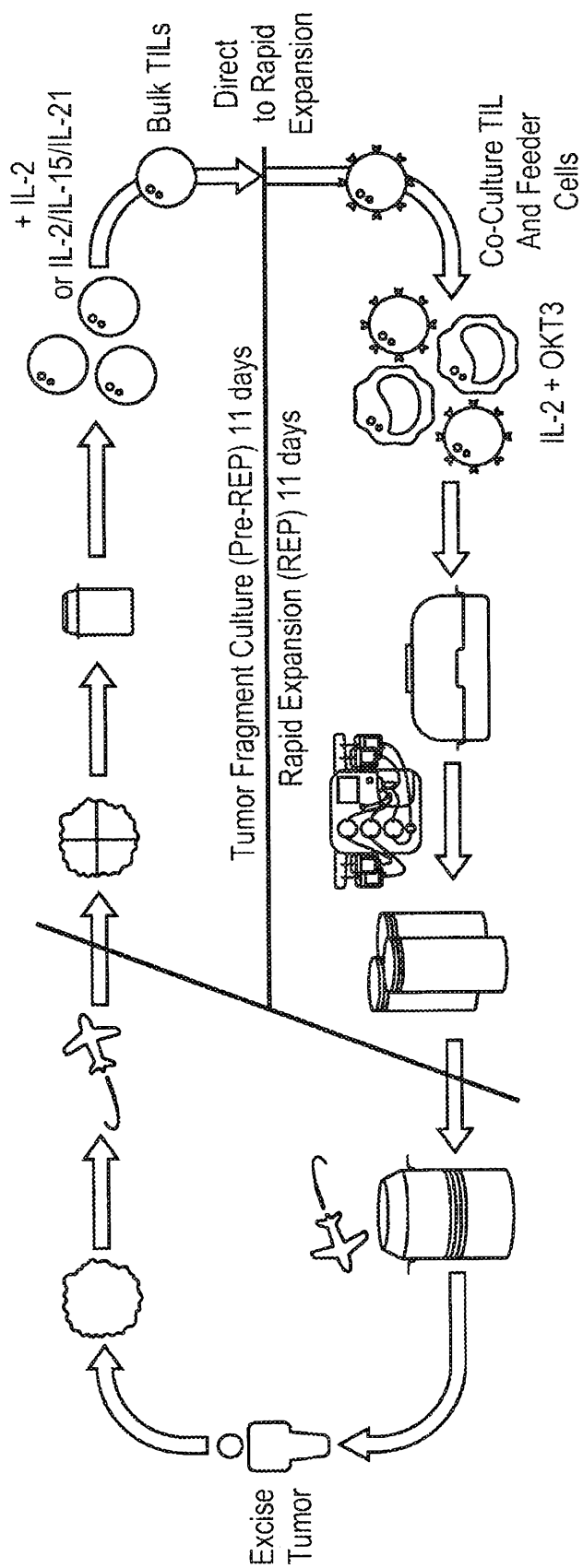

Figure 68

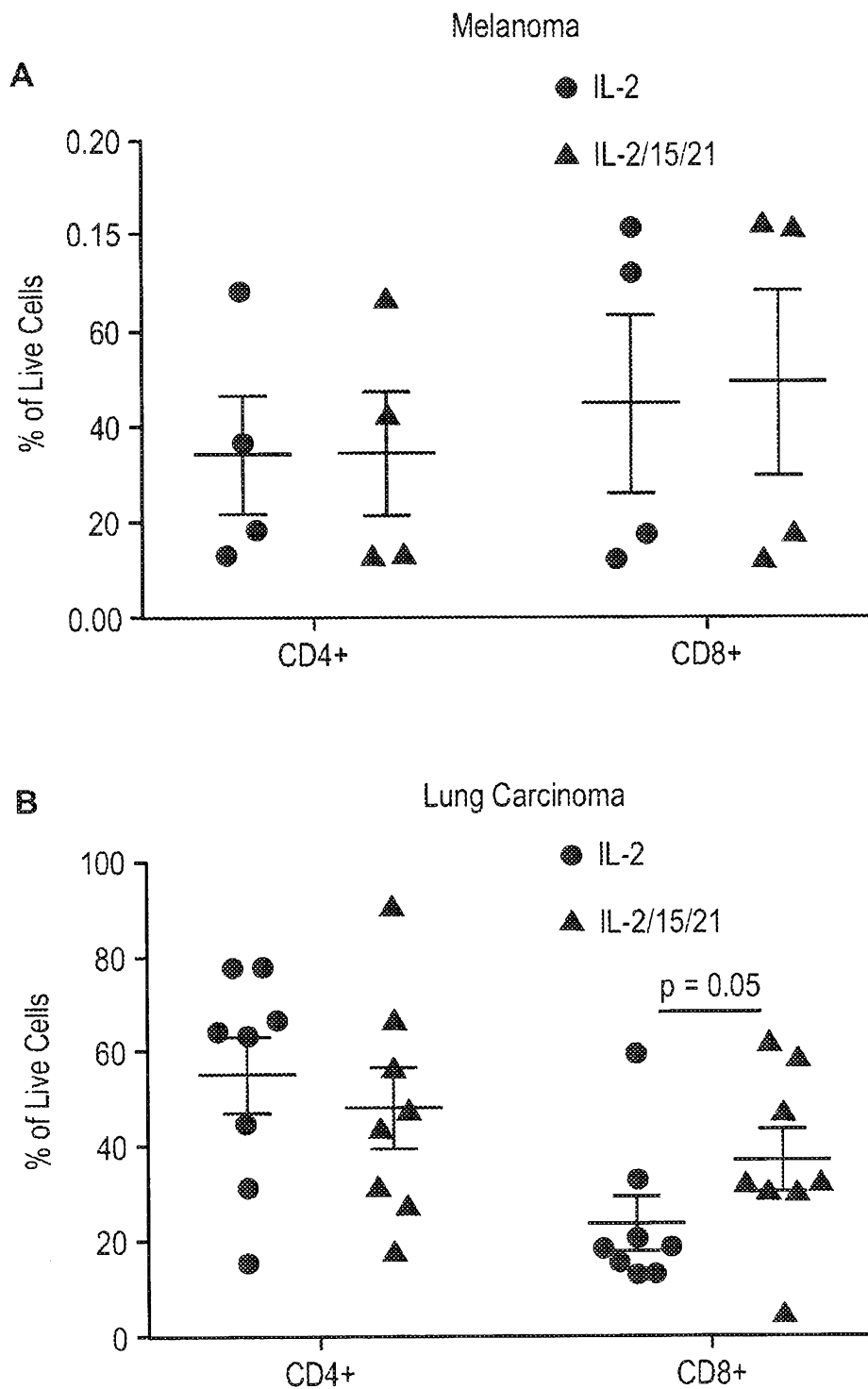

Figure 69

77/136

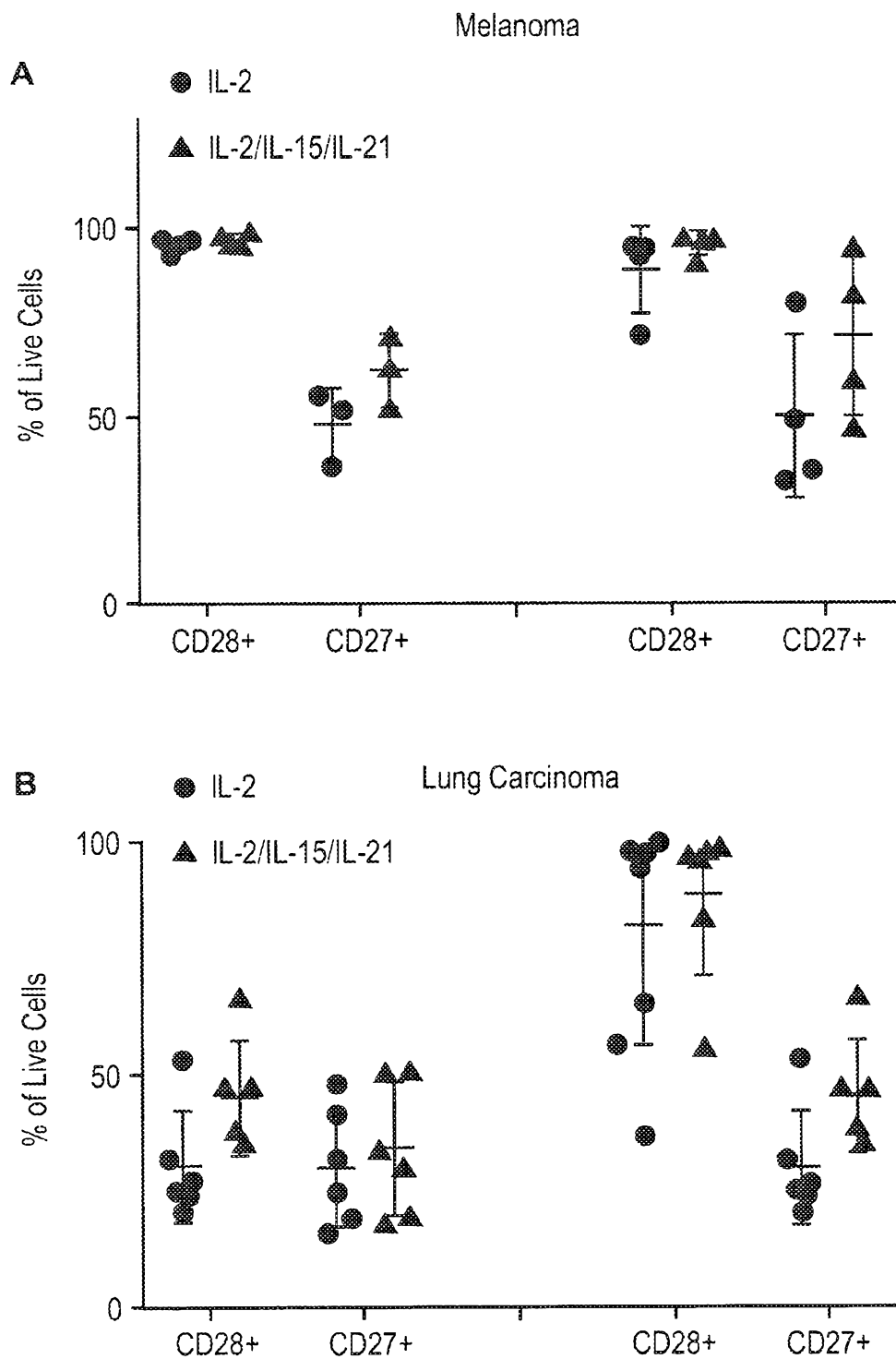

Figure 70

78/136

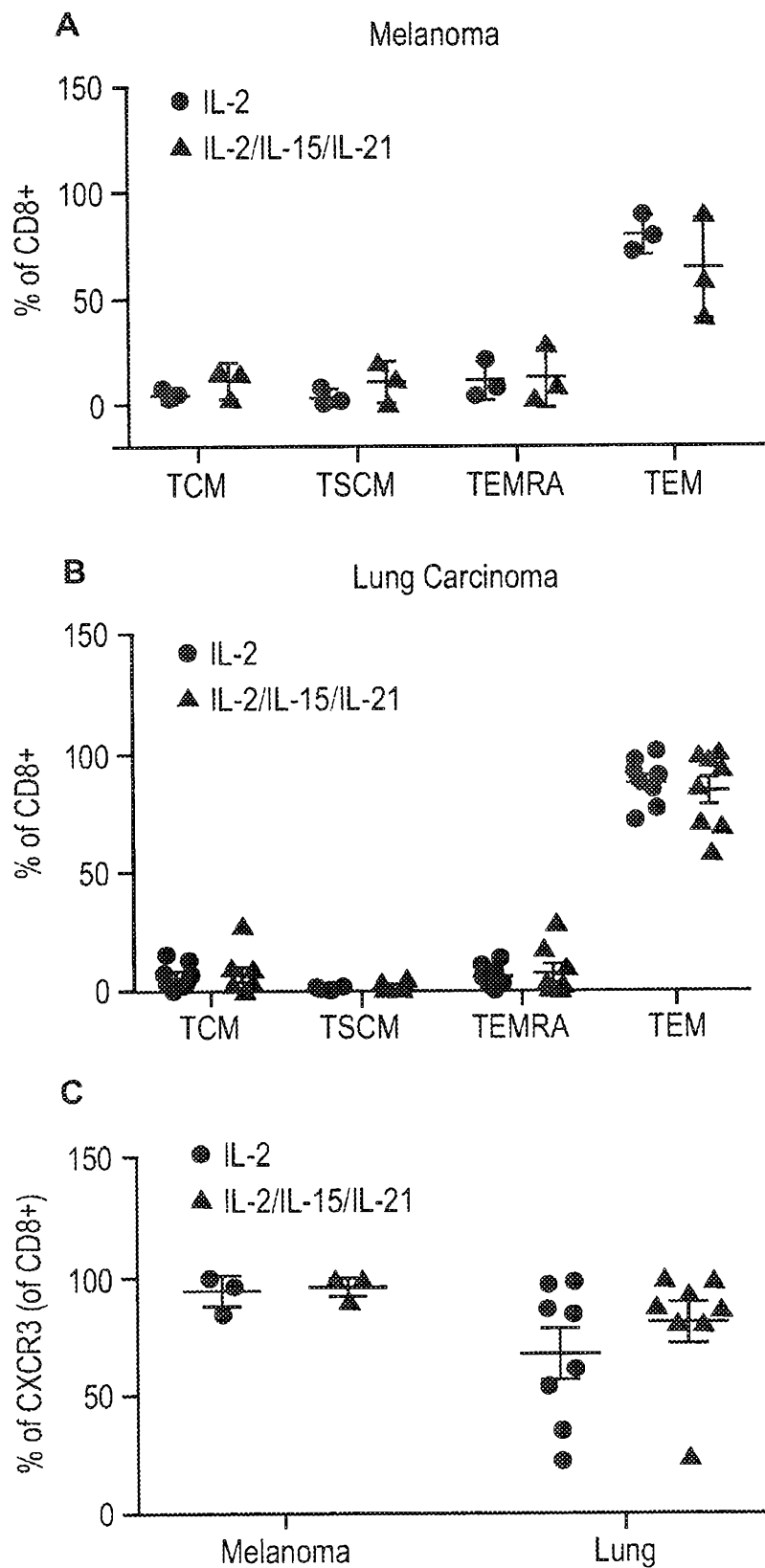

Figure 71

79/136

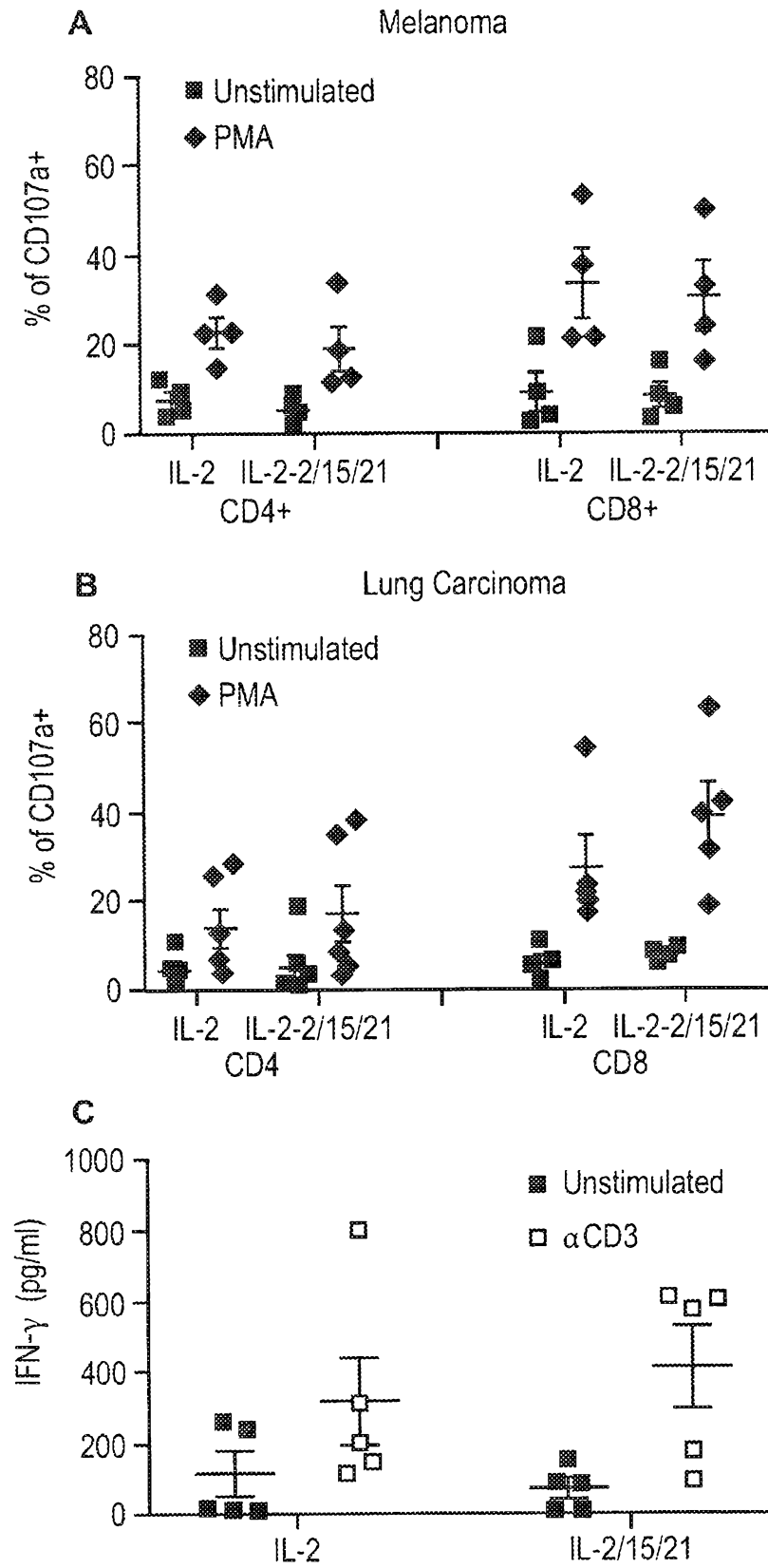

Figure 72

80/136

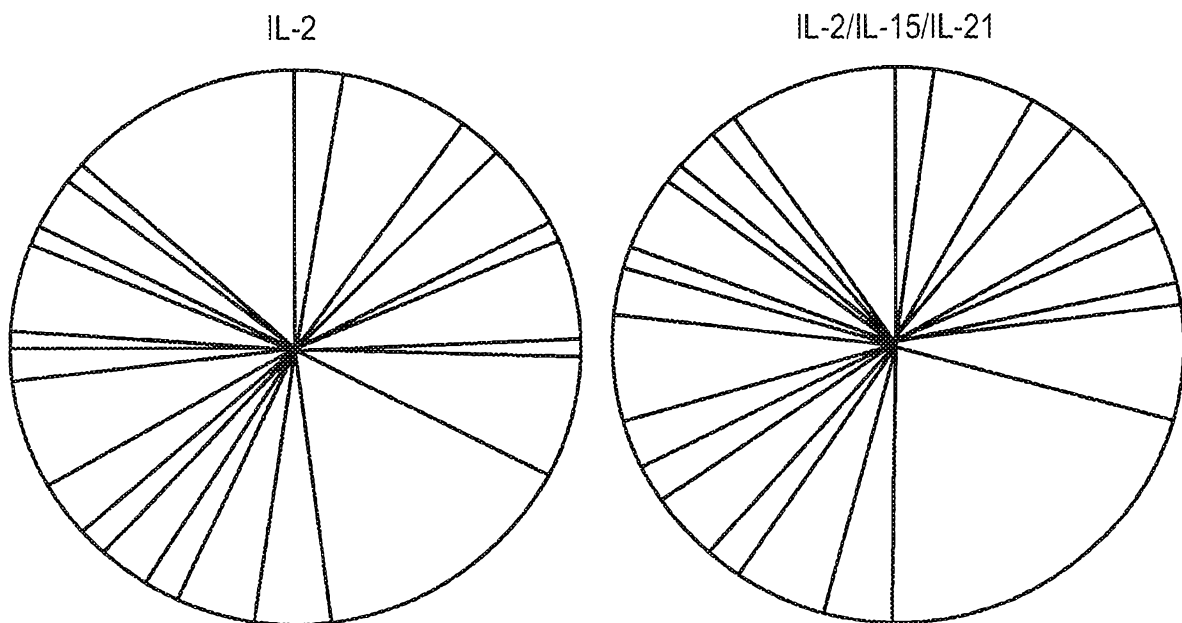
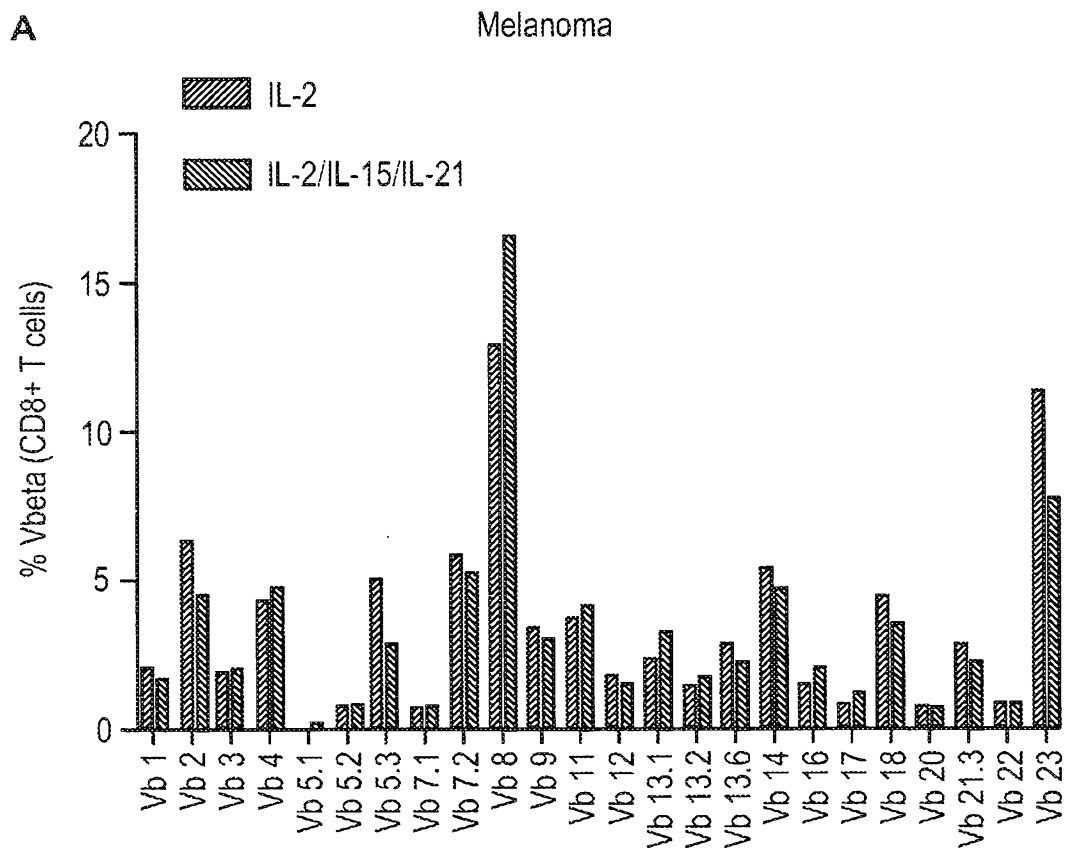

Figure 73

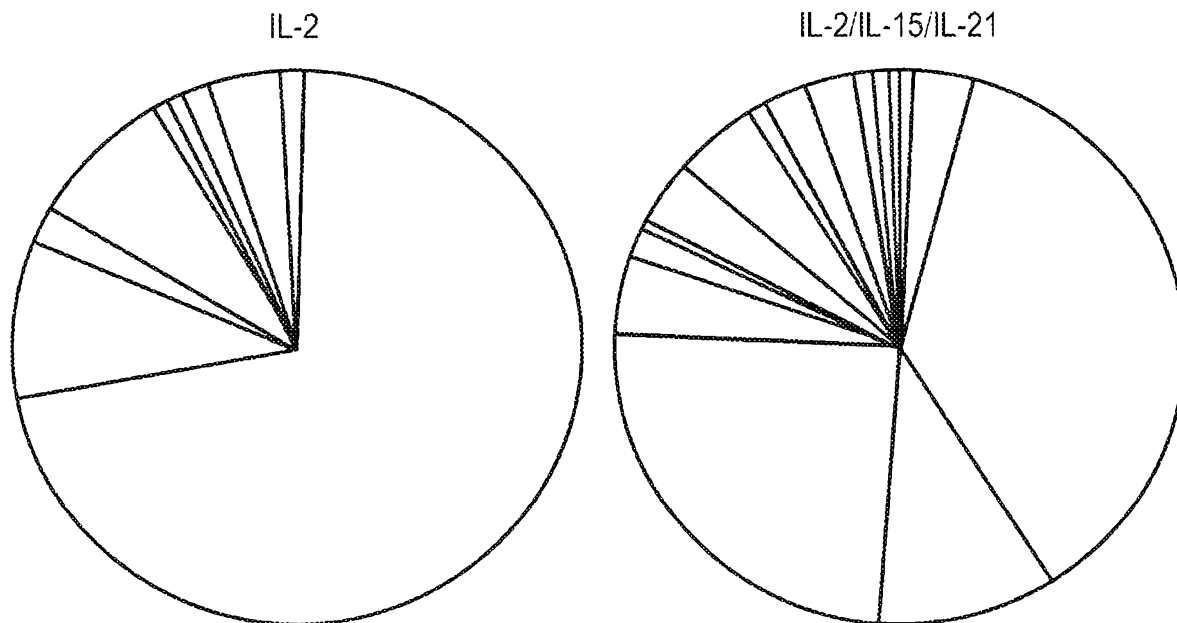
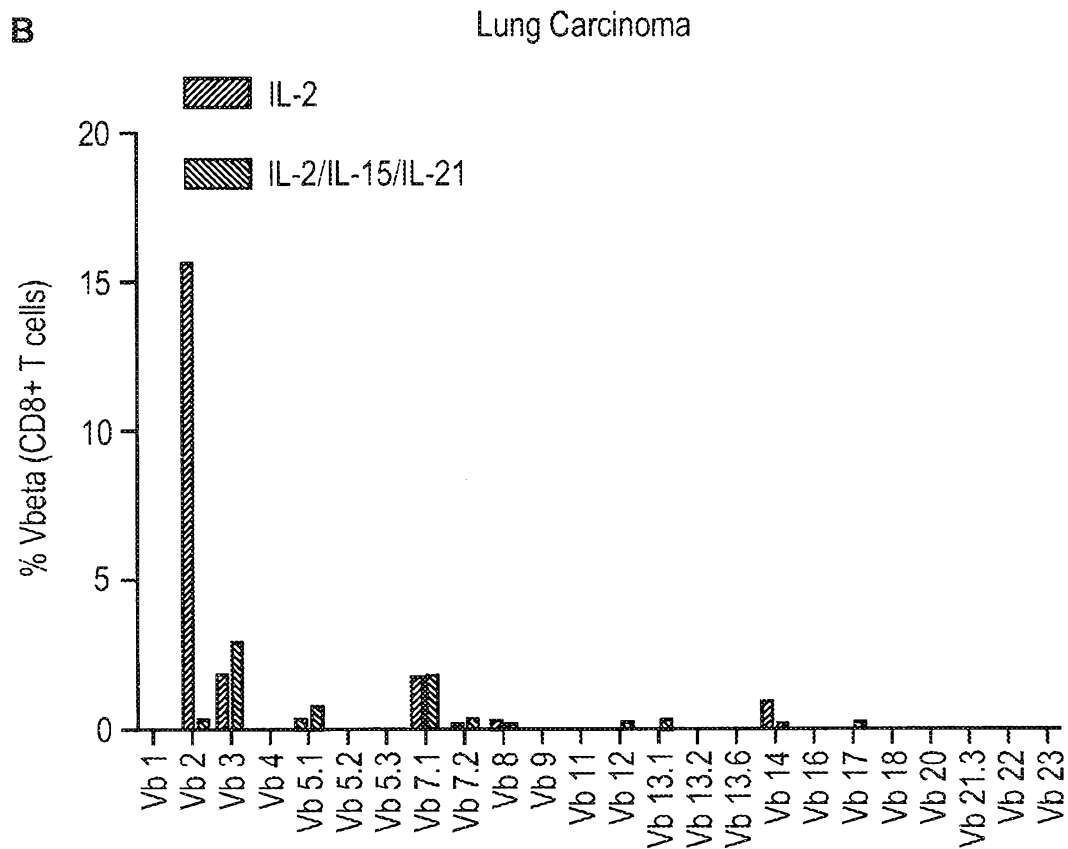

Figure 73

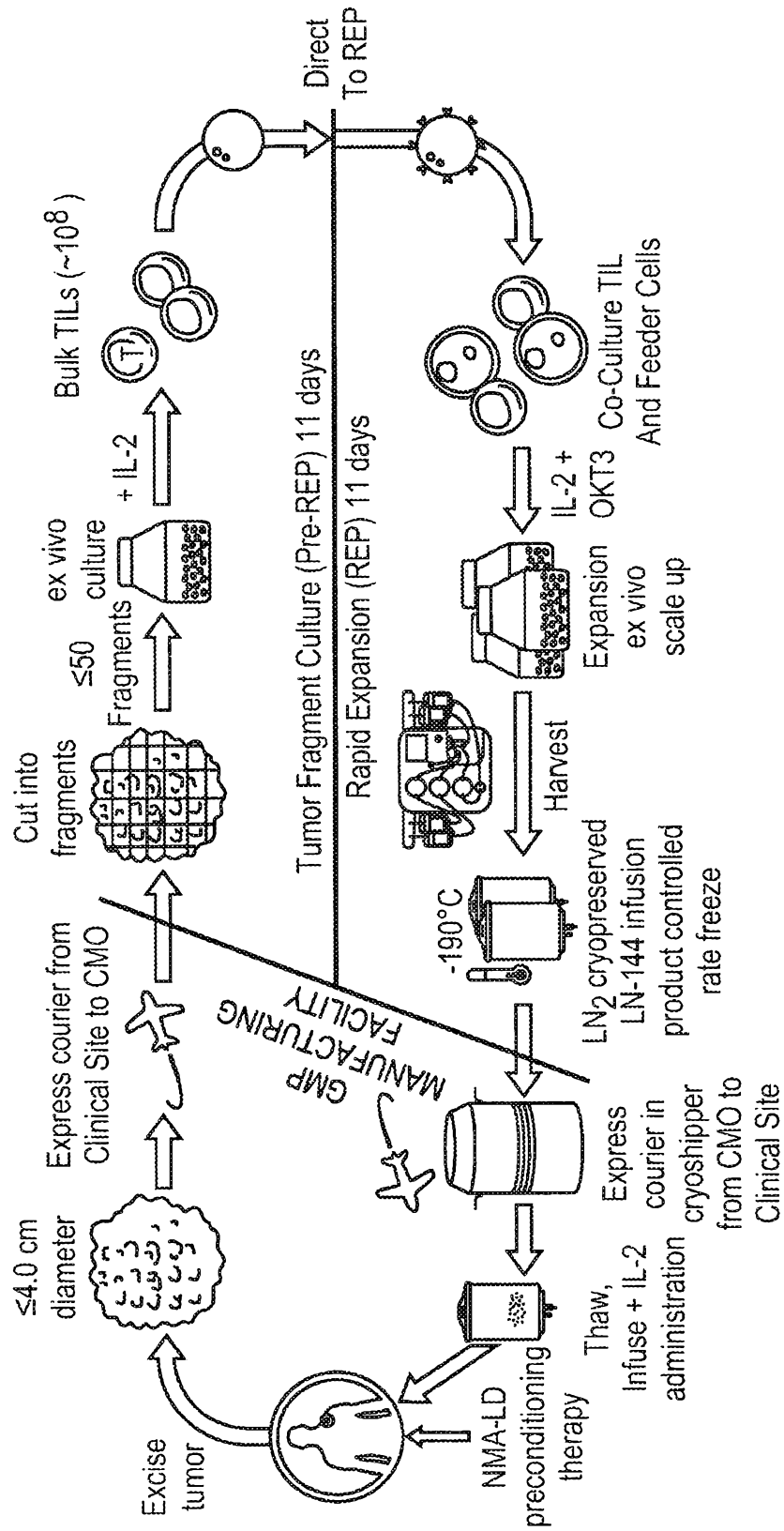

Figure 74

Figure 75

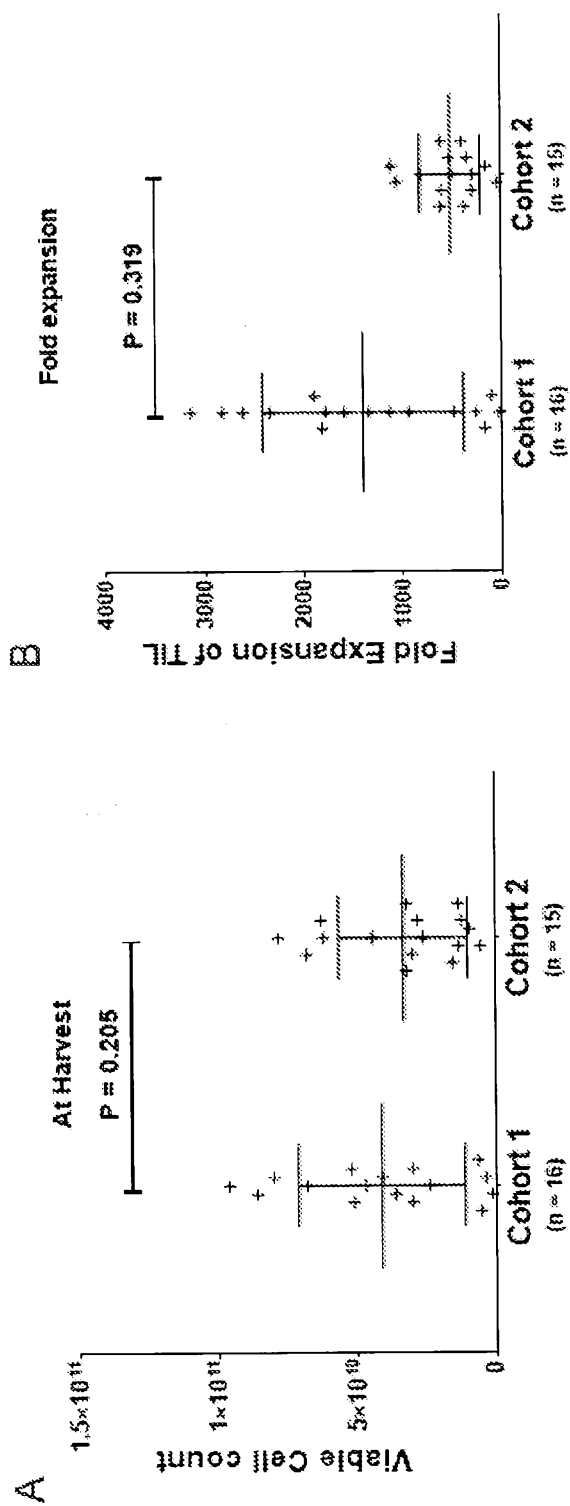

Figure 76

%CD45 CD3: Gen 1 vs. Gen 2

p=0.3 (ns)

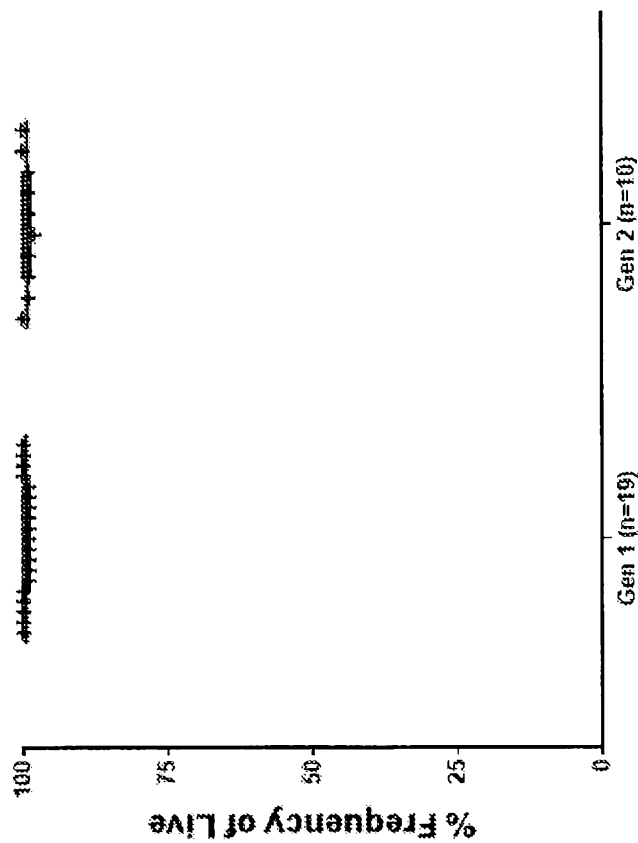

Figure 77

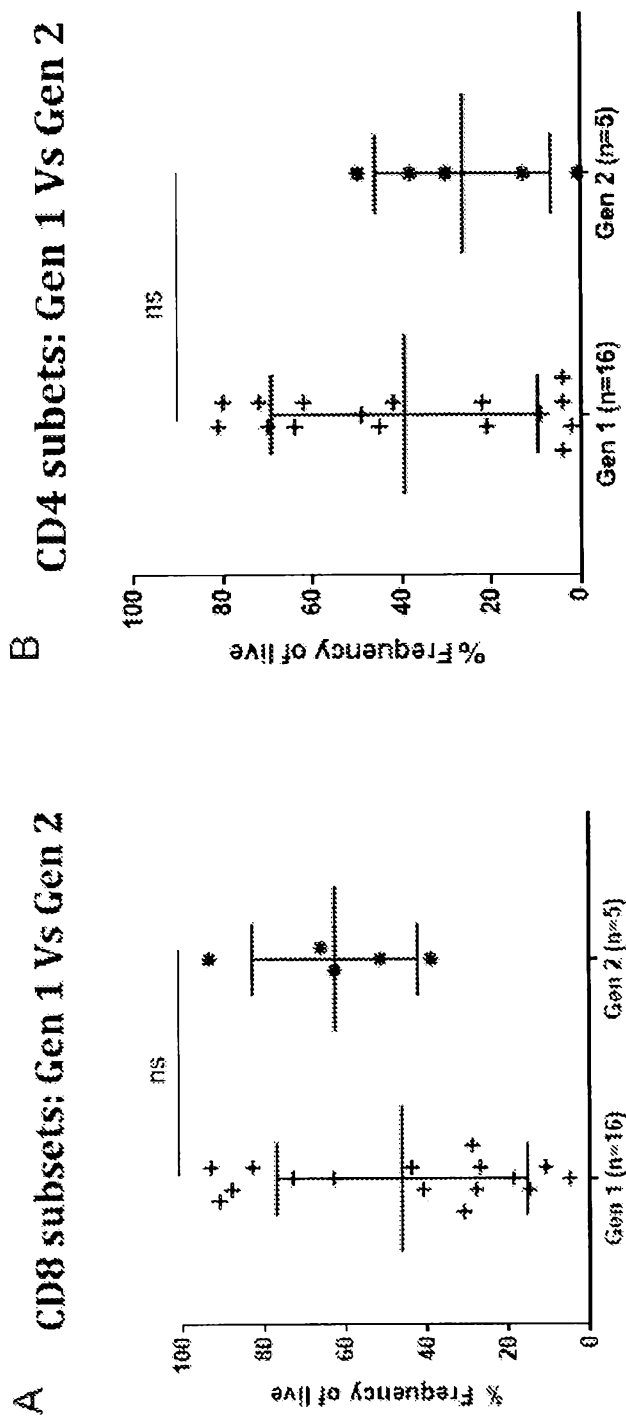

Figure 78

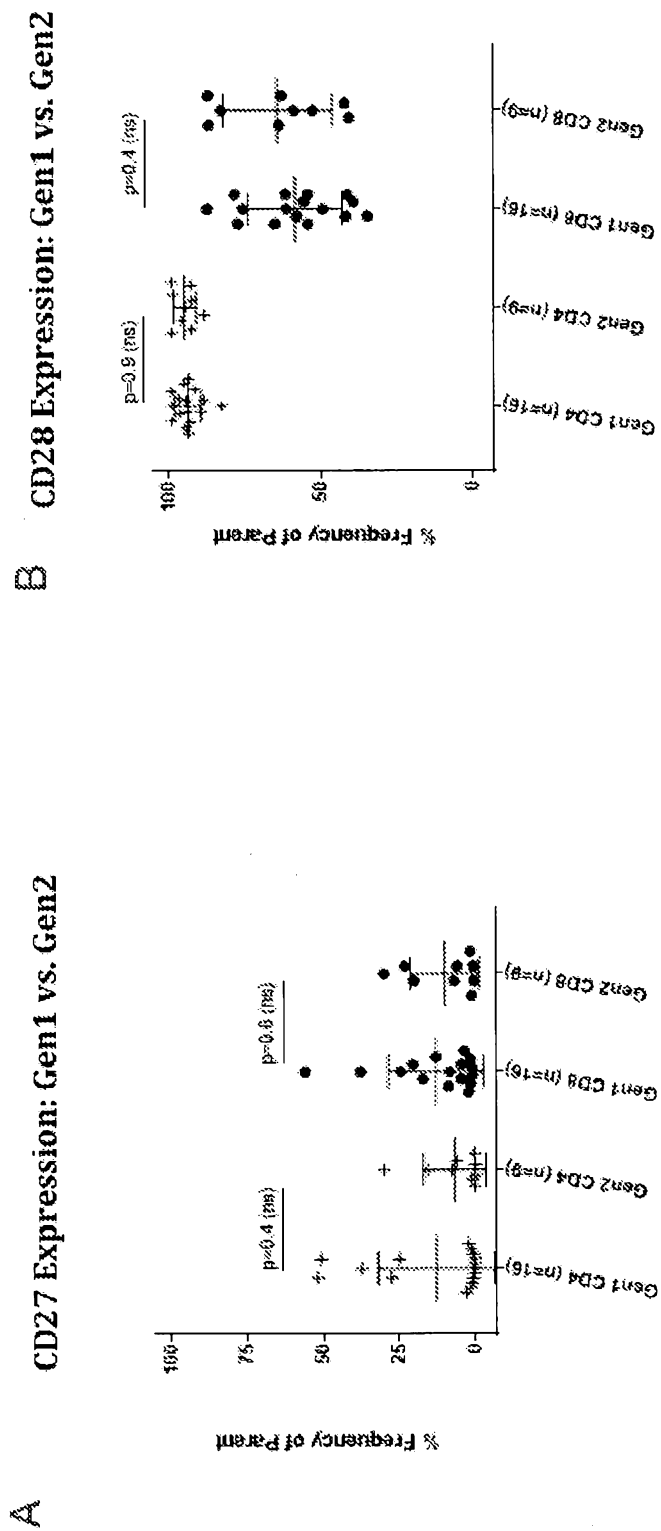

Figure 79

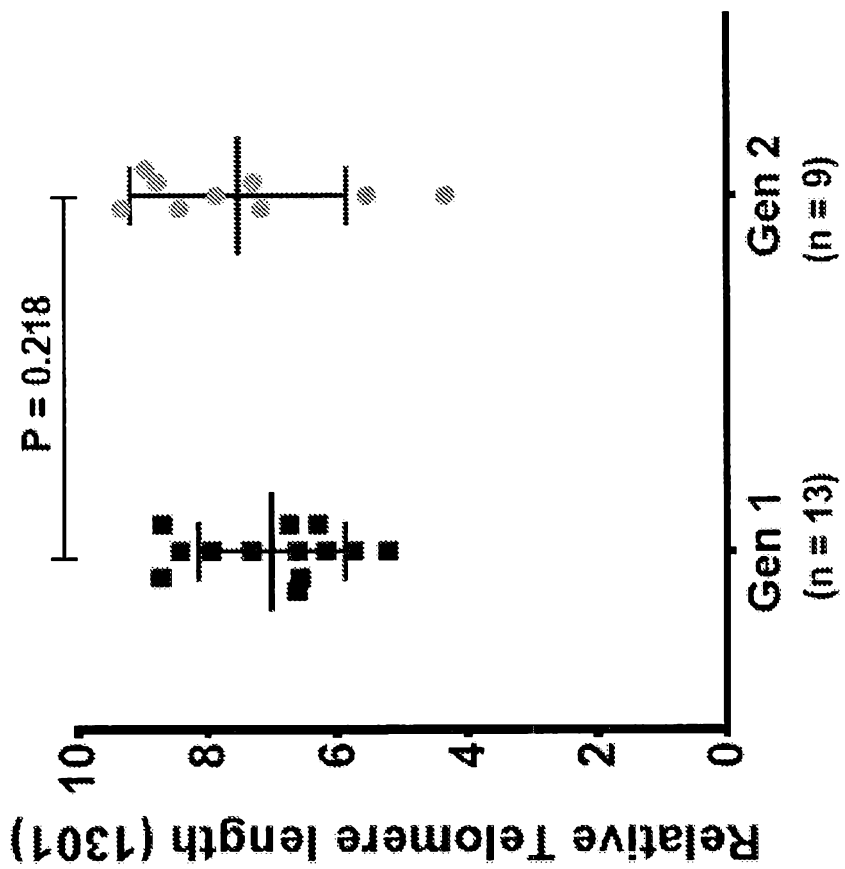

Figure 80

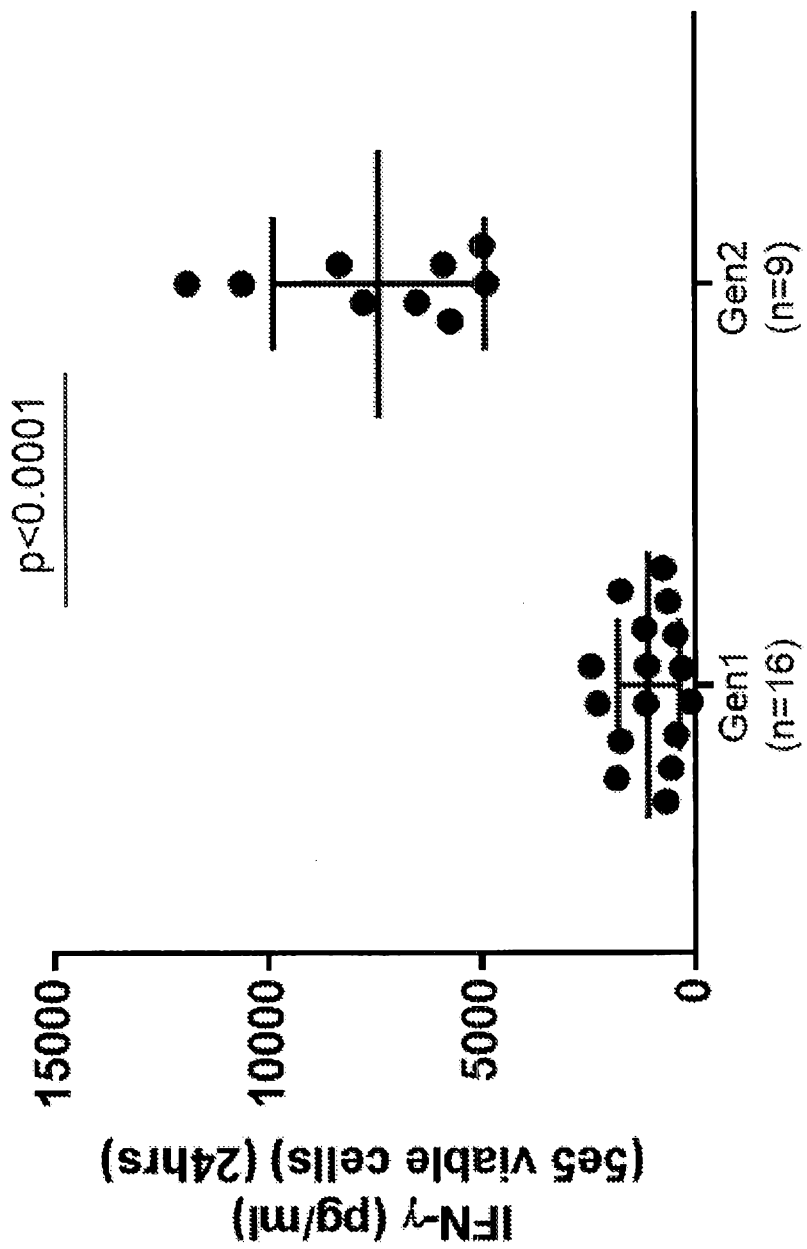
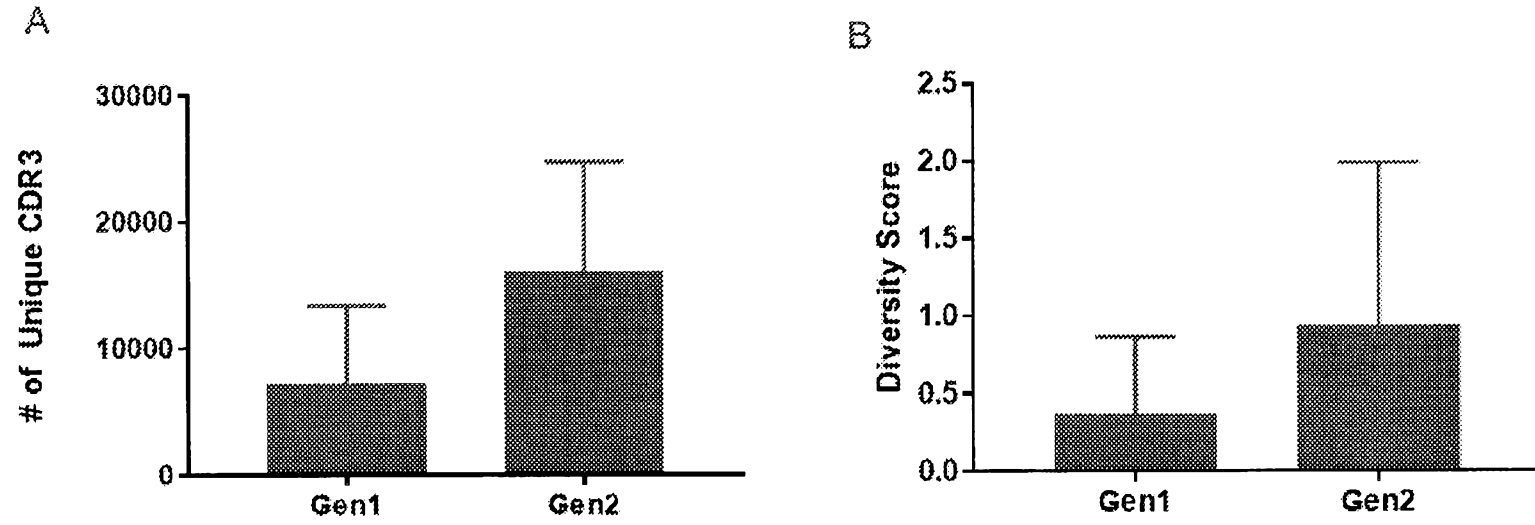



Figure 81



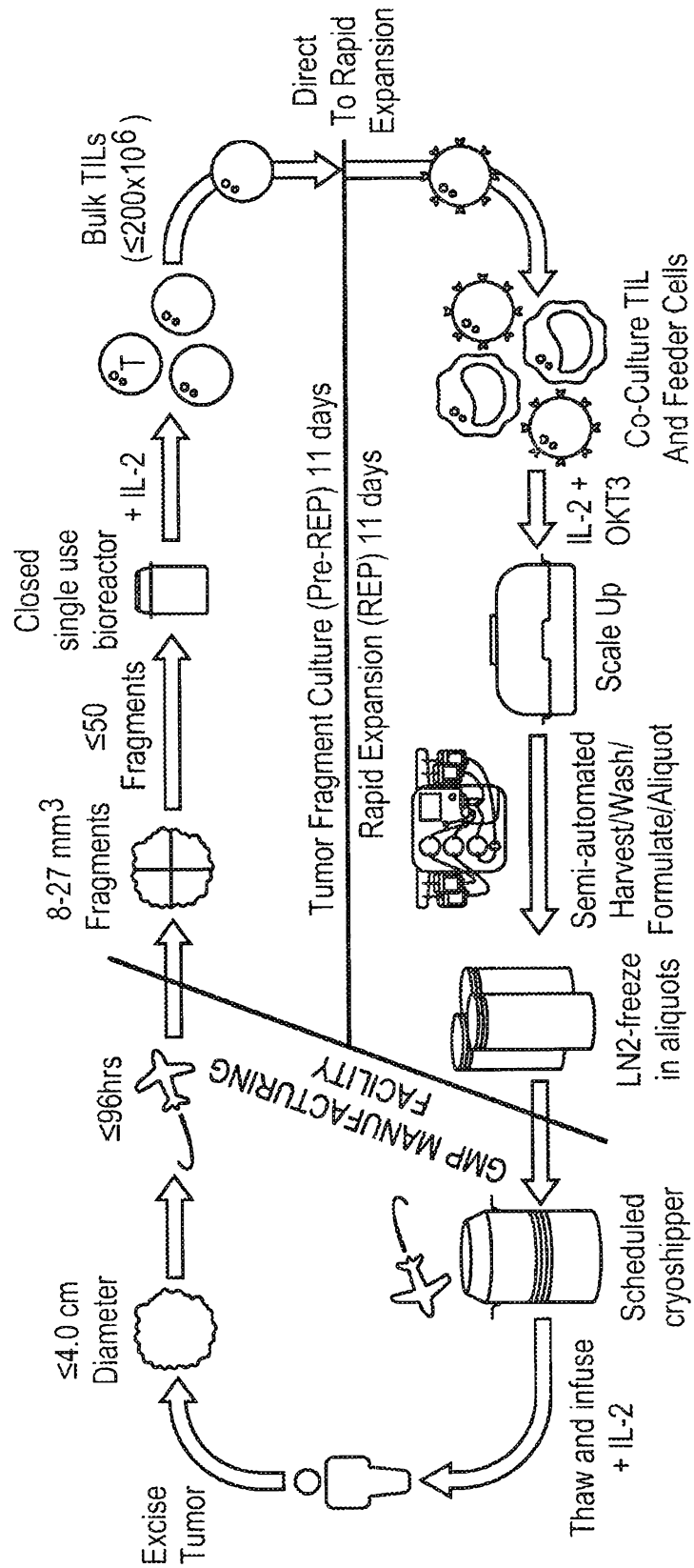

Figure 82

Figure 83

Process 1C: 43-55 Days for Steps A - E	Process 2A: about 22 days from Steps A - E
<p style="text-align: center;"><b>1. <u>STEP A</u></b></p> <p style="text-align: center;">Obtain Patient Tumor Sample</p>	<p style="text-align: center;"><b>2. <u>STEP A</u></b></p> <p style="text-align: center;">Obtain Patient Tumor Sample</p>
<p style="text-align: center;"><b>3. <u>STEP B</u></b></p> <p style="text-align: center;">Fragmentation and First Expansion 11 days to 21 days</p>	<p style="text-align: center;"><b>3. <u>STEP B</u></b></p> <p style="text-align: center;">Fragmentation and First Expansion 3 days to 14 days</p>
<p style="text-align: center;"><b>3. <u>STEP C</u></b></p> <p style="text-align: center;">First Expansion to Second Expansion Transition Optional Storage until Selection</p>	<p style="text-align: center;"><b>4. <u>STEP C</u></b></p> <p style="text-align: center;">First Expansion to Second Expansion Transition No Storage and Closed System</p>
<p style="text-align: center;"><b>5. <u>STEP D</u></b></p> <p style="text-align: center;">Second Expansion IL-2, OKT-3, antigen-presenting feeder cells Optionally repeat one or more times</p>	<p style="text-align: center;"><b>5. <u>STEP D</u></b></p> <p style="text-align: center;">Second Expansion IL-2, OKT-3, and antigen-presenting feeder cells Closed System</p>
<p style="text-align: center;"><b>6. <u>STEP E</u></b></p> <p style="text-align: center;">Harvest TILS from Step D</p>	<p style="text-align: center;"><b>7. <u>STEP E</u></b></p> <p style="text-align: center;">Harvest TILS from Step D Closed System</p>
<p style="text-align: center;"><b>6. <u>STEP F</u></b></p> <p style="text-align: center;">Final Formulation and/or Transfer to Infusion Bag</p>	<p style="text-align: center;"><b>8. <u>STEP F</u></b></p> <p style="text-align: center;">Final Formulation and/or Transfer to Infusion Bag (optionally cryopreserve)</p>

Figure 84

Process Step	Process 1C Embodiment	Process 2A Embodiment	Advantages
Pre-REP	<ul style="list-style-type: none"> <li>4 fragments per 10 GREX-10 flasks</li> <li>11-21 day duration</li> </ul>	<ul style="list-style-type: none"> <li>40 fragments per 1 GREX-100M flask</li> <li>11 day duration</li> </ul>	<ul style="list-style-type: none"> <li>Increased tumor fragments per flask</li> <li>Shortened culture time</li> <li>Reduced number of steps</li> <li>Amenable to closed system</li> </ul>
Pre-REP to REP Transition	<ul style="list-style-type: none"> <li>Pre-REP TIL are frozen until phenotyped for selection then thawed to proceed to the REP (~day 30)</li> <li>REP requires <math>&gt;40 \times 10^6</math> TIL</li> </ul>	<ul style="list-style-type: none"> <li>Pre-REP TIL directly move to REP on day 11</li> <li>REP requires 25-<math>200 \times 10^6</math> TIL</li> </ul>	<ul style="list-style-type: none"> <li>Shortened pre-REP-to-REP process</li> <li>Reduced number of steps</li> <li>Eliminated phenotyping selection</li> <li>Amenable to closed system</li> </ul>
REP	<ul style="list-style-type: none"> <li>6 GREX-100M flasks on REP day 0</li> <li><math>5 \times 10^6</math> TIL and <math>5 \times 10^8</math> PBMC feeders per flask on REP day 0</li> <li>Split to 18-36 flasks on REP day 7</li> <li>14 day duration</li> </ul>	<ul style="list-style-type: none"> <li>1 GREX-500M flask on day 11</li> <li><math>25-200 \times 10^6</math> TIL and <math>5 \times 10^9</math> PBMC feeders on day 11</li> <li>Split to <math>\leq 6</math> GREX-500M flasks on day 16</li> <li>11 day duration</li> </ul>	<ul style="list-style-type: none"> <li>Reduced number of steps</li> <li>Shorter REP duration</li> <li>Closed system transfer of TIL between flasks</li> <li>Closed system media exchanges</li> </ul>
Harvest	<ul style="list-style-type: none"> <li>TIL harvested via centrifugation</li> </ul>	<ul style="list-style-type: none"> <li>TIL harvested via LOVO automated cell washing system'</li> </ul>	<ul style="list-style-type: none"> <li>Reduced number of steps</li> <li>Automated cell washing</li> <li>Closed system</li> <li>Reduced loss of product during wash</li> </ul>
Final Formulation	<ul style="list-style-type: none"> <li>Fresh product in Hypothermosol</li> <li>Single infusion bag</li> <li>Limited shipping stability</li> </ul>	<ul style="list-style-type: none"> <li>Cyropreserved product in PlasmaLyte-A + 1% HSA and CS10 stored in LN<sub>2</sub></li> <li>Multiple aliquots</li> <li>Longer shipping stability</li> </ul>	<ul style="list-style-type: none"> <li>Shipping flexibility</li> <li>Flexible patient scheduling</li> <li>More timely release testing</li> </ul>
Overall Estimated Process Time	<ul style="list-style-type: none"> <li>43-55 days</li> </ul>	<ul style="list-style-type: none"> <li>22 days</li> </ul>	<ul style="list-style-type: none"> <li>Faster turnaround to patient</li> </ul>

Figure 85

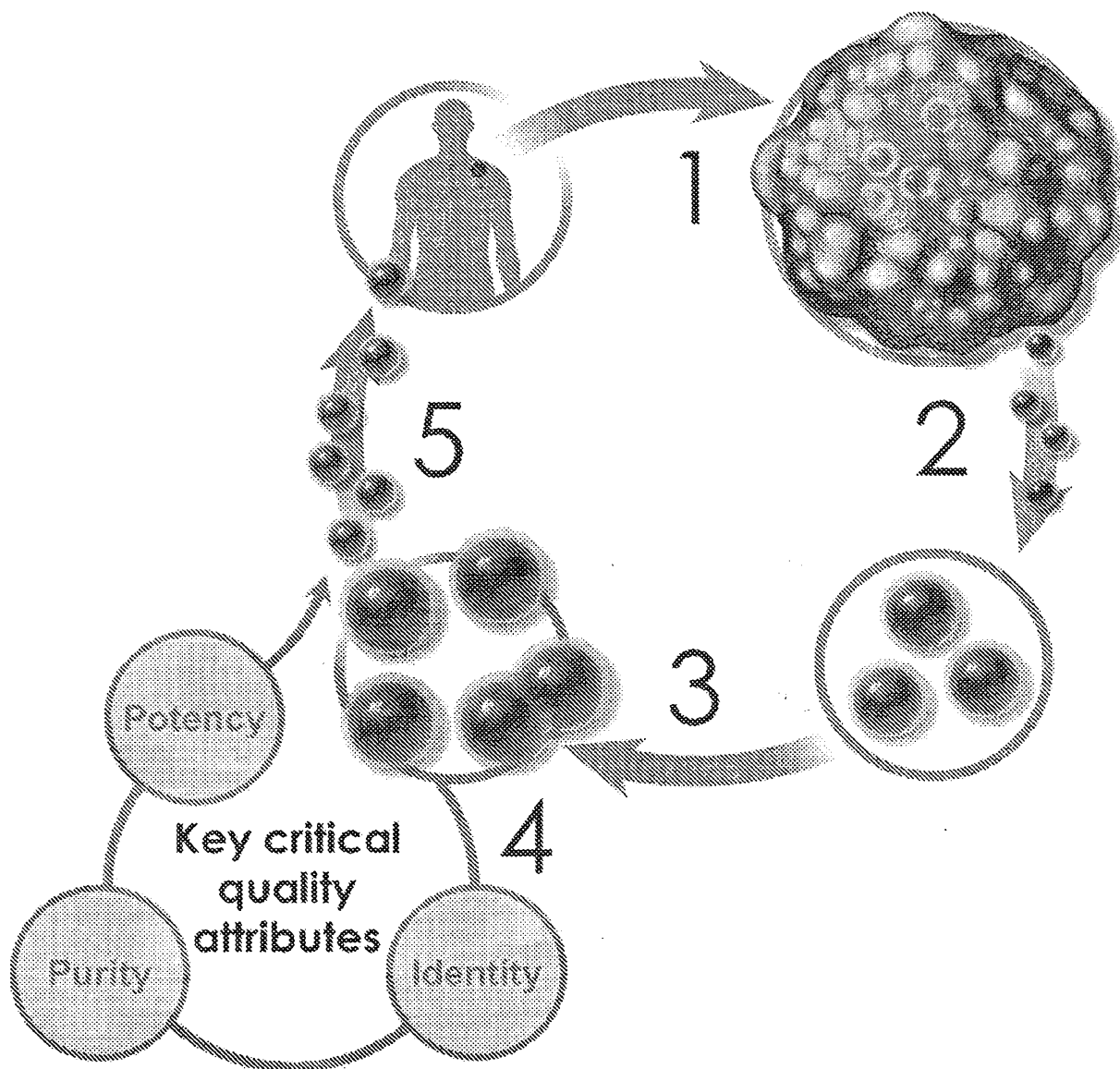

94/136

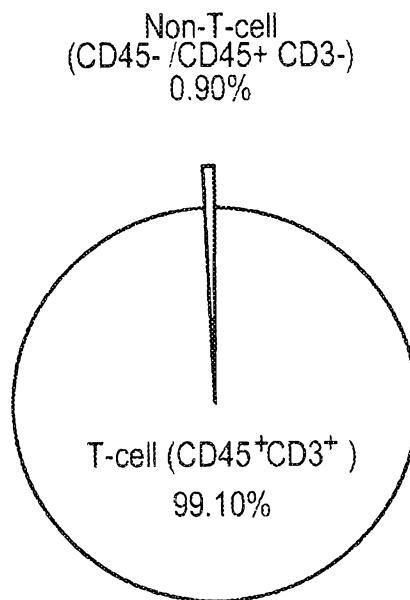

Figure 86A

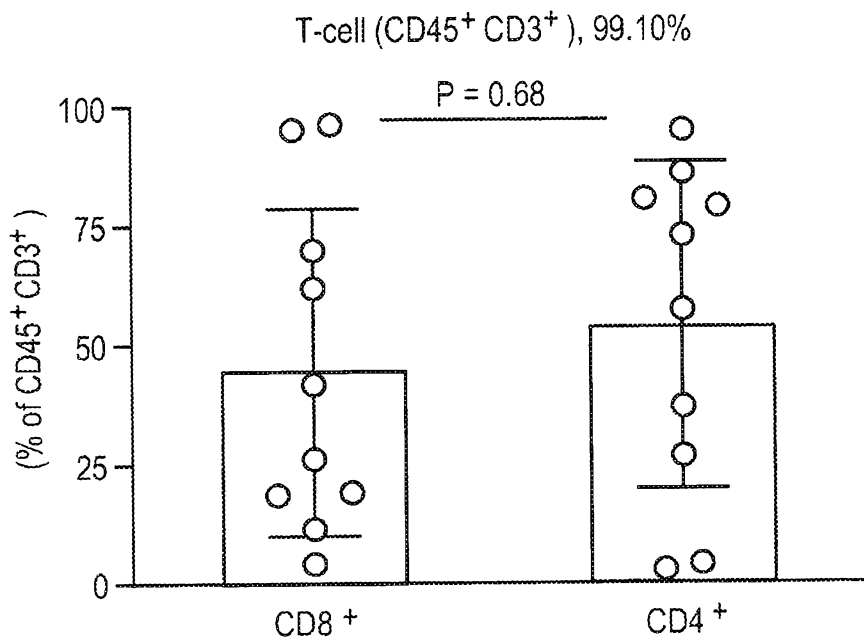

Figure 86B

95/136

Non-T-cell  
(CD45<sup>-</sup> /CD45<sup>+</sup> CD3<sup>-</sup>), 0.90%

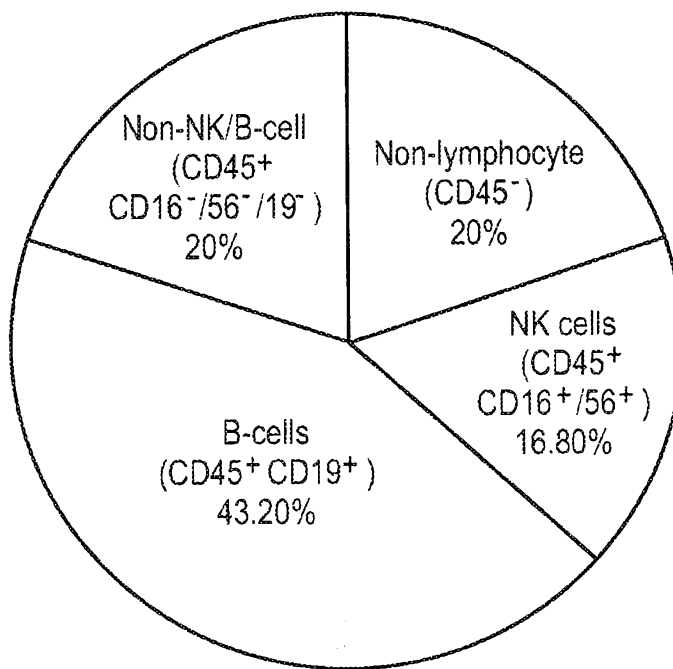

Figure 86C



97/136

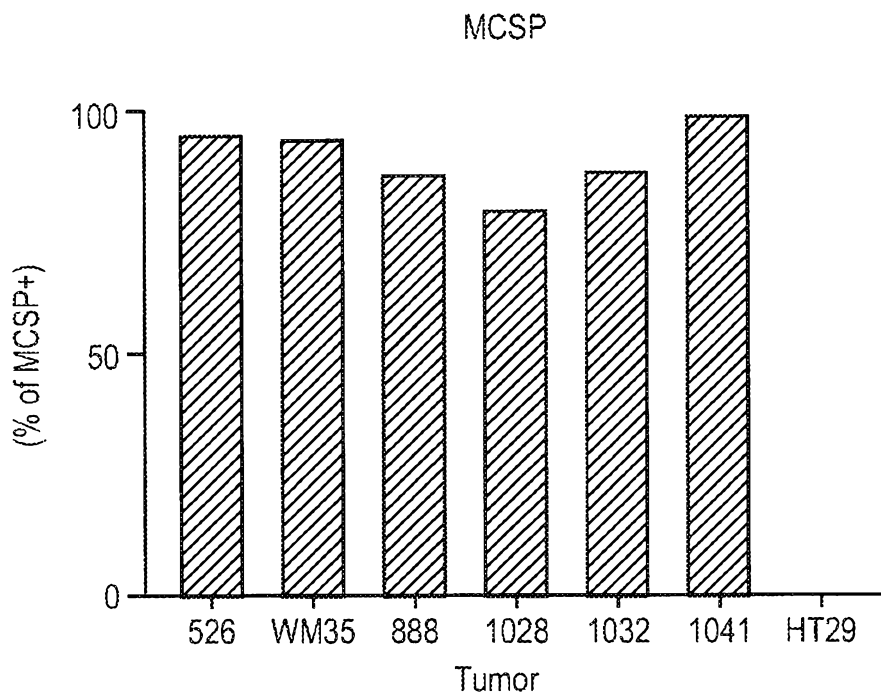

Figure 88A

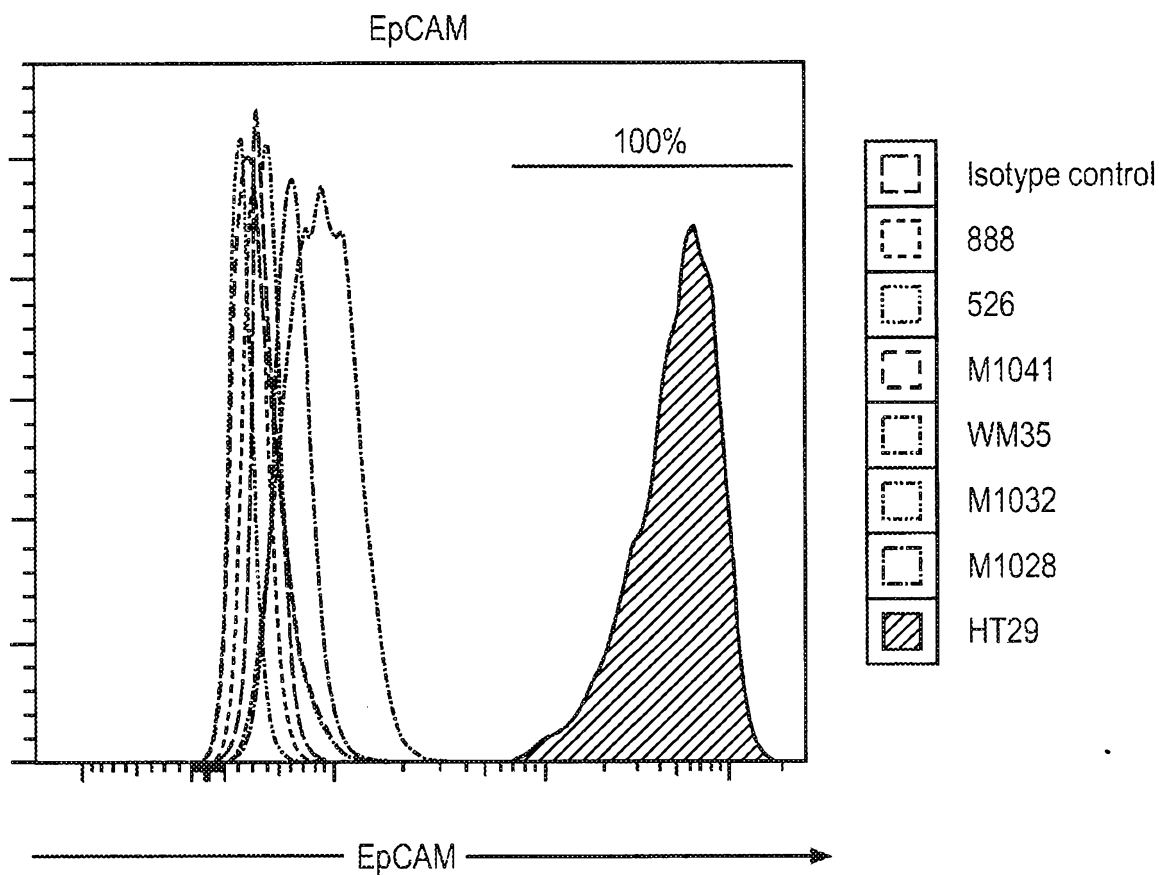

Figure 88B

98/136

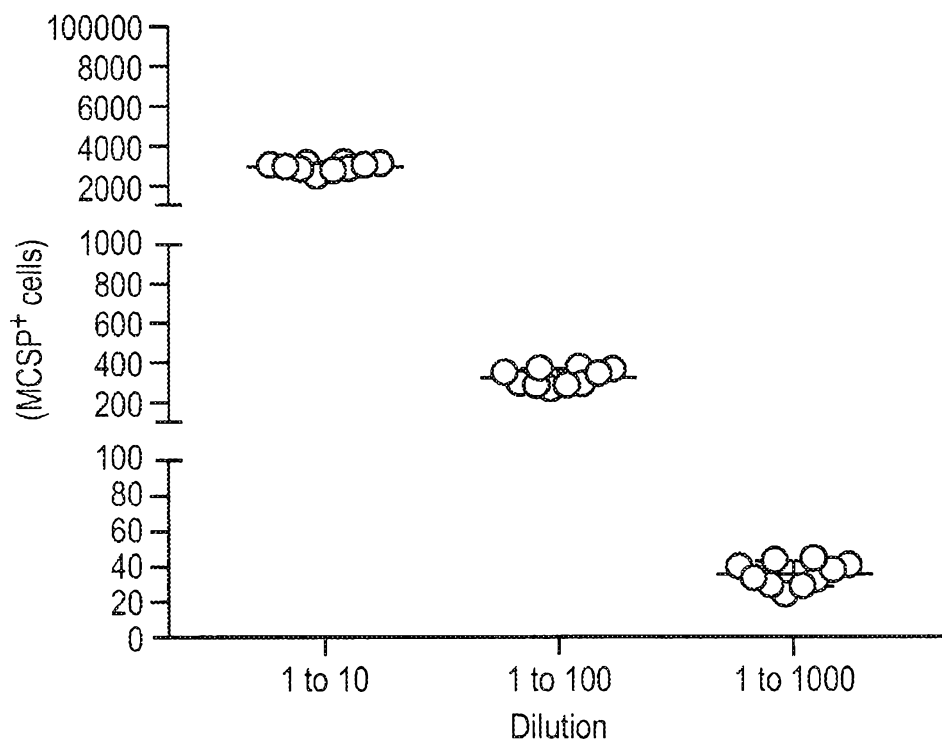

Figure 89A

DILUTION	AV	SD	UPPER LIMIT (AV + 3SD)	LOWER LIMIT (AV - 3SD)
1 to 10	2976	203	3585	2367
1 to 100	322	39	440	204
1 to 1000	36	7	56	16

Figure 89B

DILUTION	RANGE (UPPER- LOWER)	EXP#1 (AV)	EXP#2 (AV)	EXP#3 (AV)
1 to 10	3585-2367	2814	3282	2367
1 to 100	440-204	227	320	239
1 to 1000	56-16	27	25	32

Figure 90A

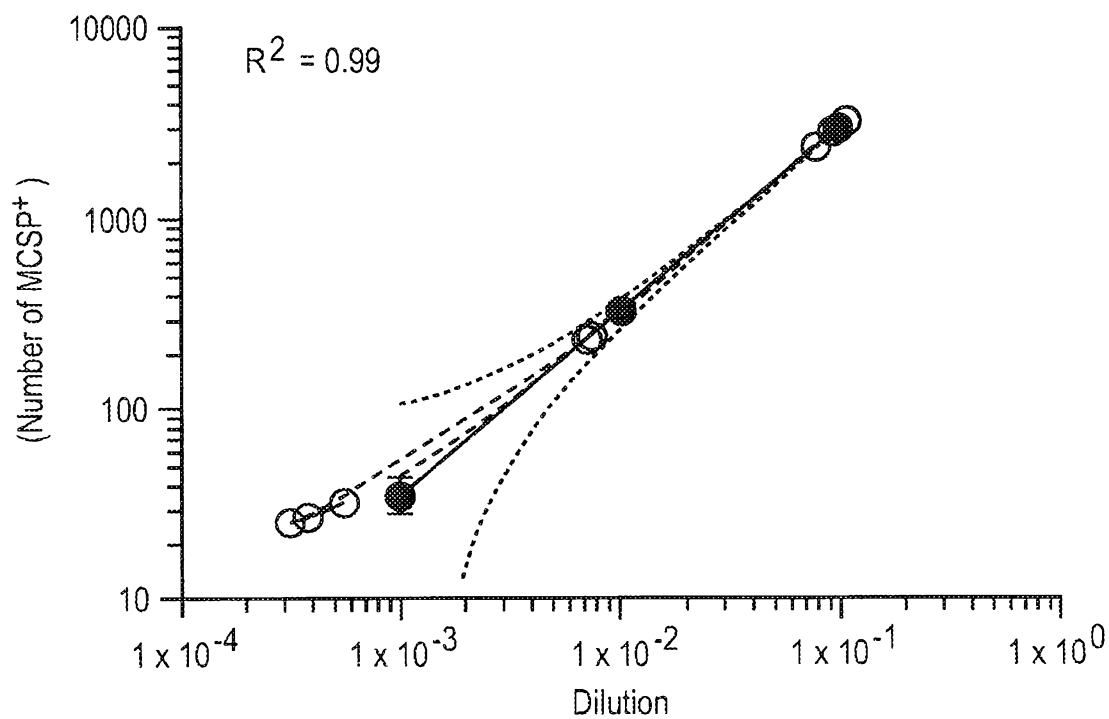

Figure 90B

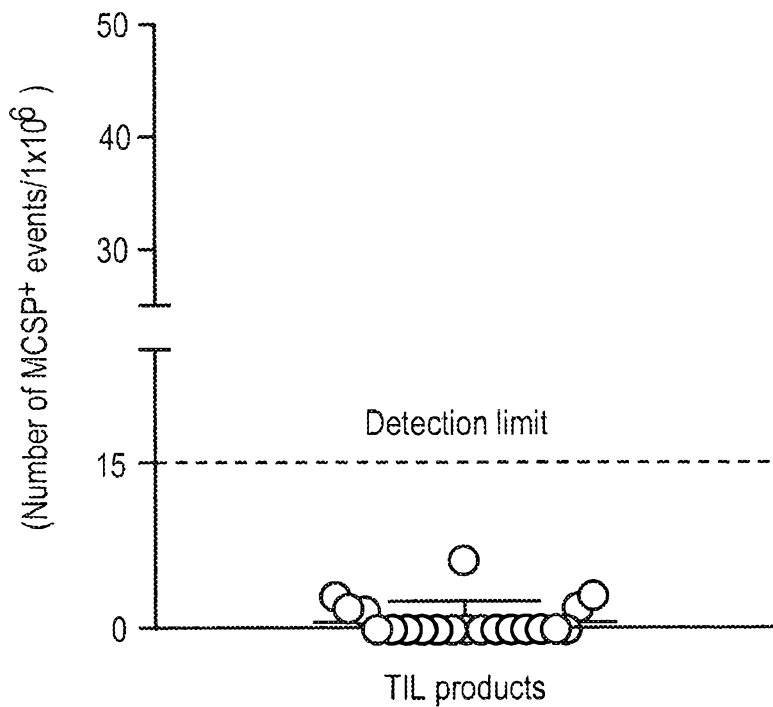
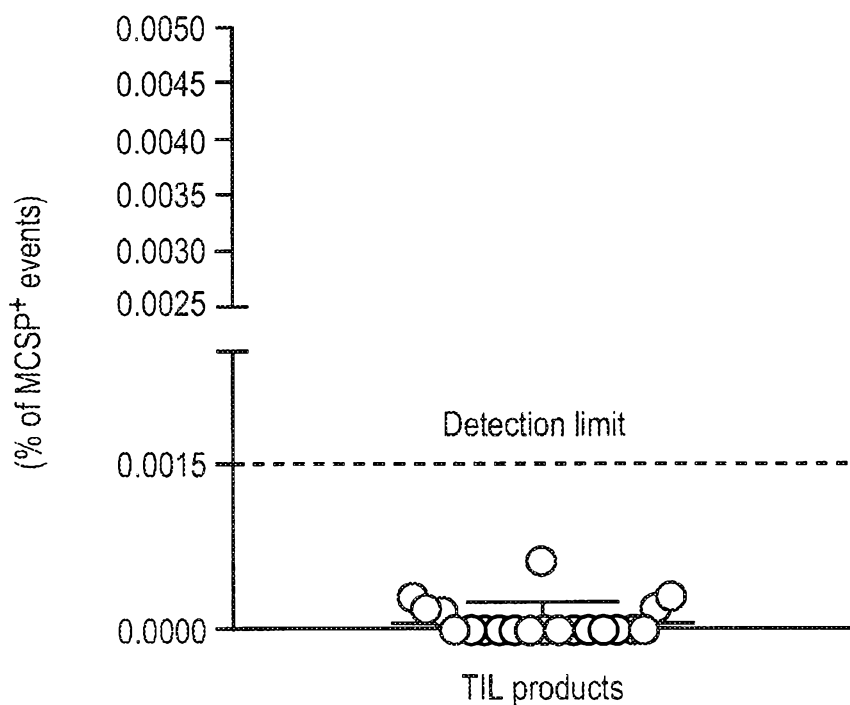

Figure 91A



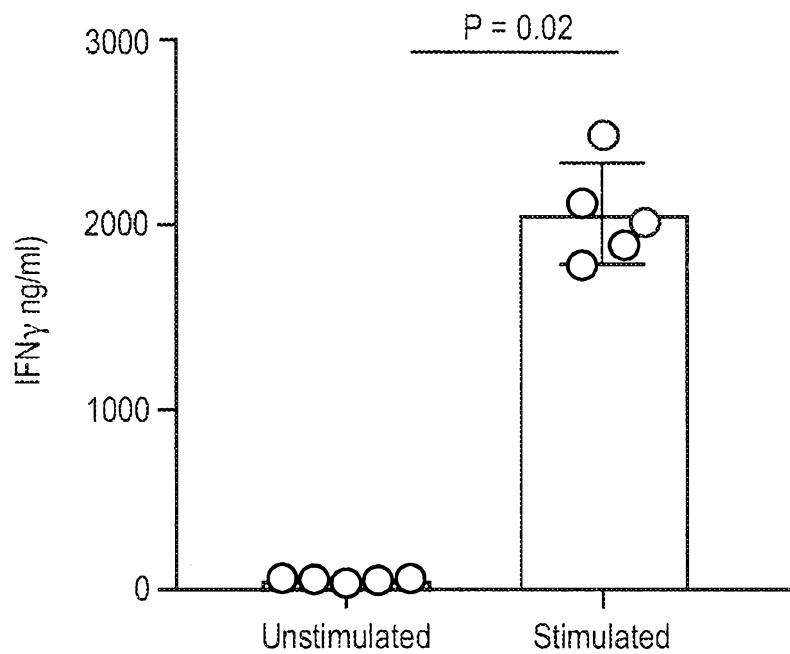

Figure 92

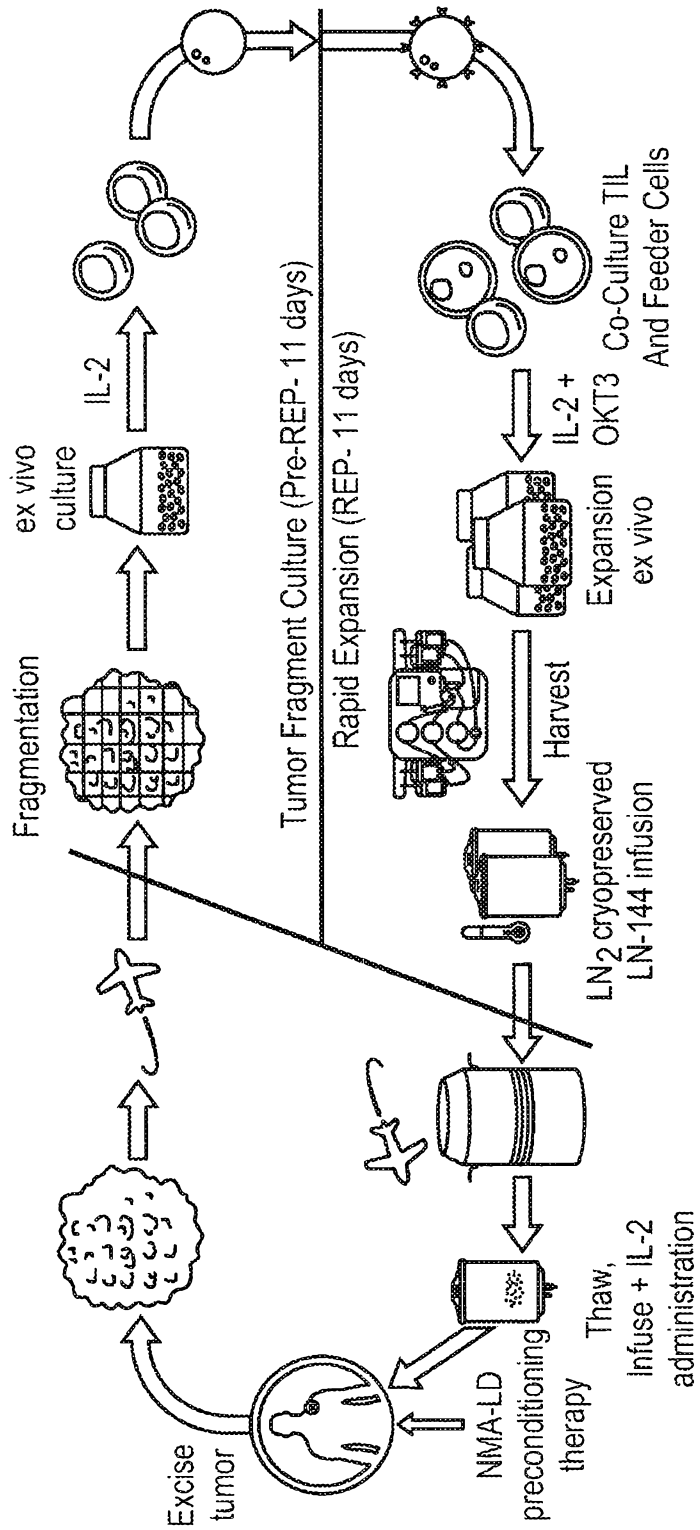

Figure 93

**Figure 94**

PROCESS STEP	GEN 1	GEN 2	IMPACT
<b>Fragment Culture</b>	≤21 days, multiple bioreactors, multiple operator interventions	≤11 days, single closed bioreactor, no intervention	Shortens culture, reduces interventions
<b>TIL selection</b>	IL-2 expanded TIL cryopreserved, tested, selection based on phenotype, thaw, rest, co-culture	Bulk TIL direct to co-culture	Reduces steps, eliminates testing, increases clonal diversity
<b>Harvest/ Wash</b>	Manual volume reduction and harvest. Manual wash and concentration	Closed semi-automated volume reduction and harvest. Automated wash and concentration	Reduces operator interventions, reduces processing time, maintains functionally closed system
<b>Formulation</b>	Fresh hypothermic product (2- 8°C)	Cryopreserved product (≤ -150°C)	Allows for global trials through increased flexibility in shipping and patient scheduling
<b>Manufacturing Time</b>	38 day process time	22 day process time	Turnaround to patient, clean room throughput, lower cost of goods

104/136

Figure 95A

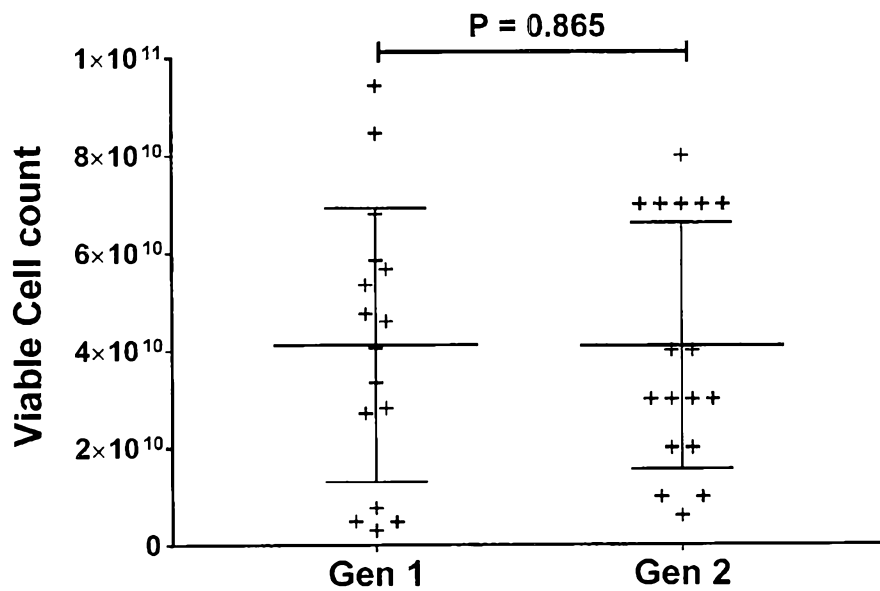
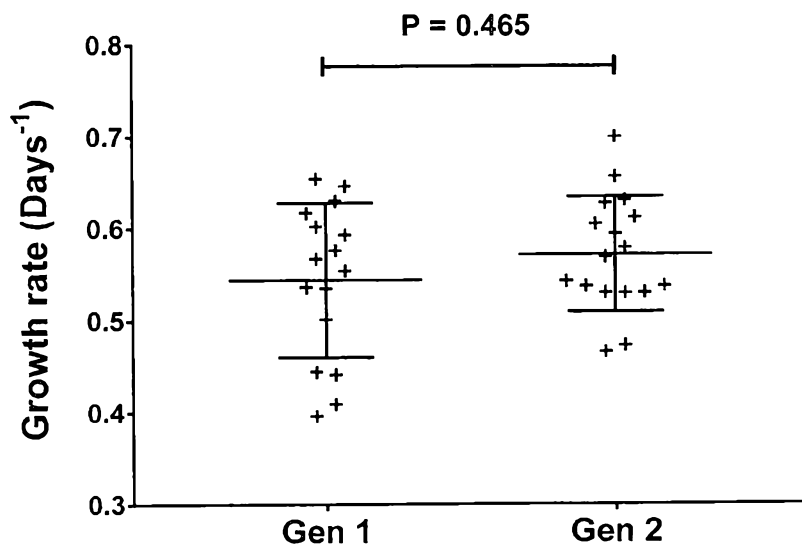

Figure 95B



105/136

Figure 95C

Viability

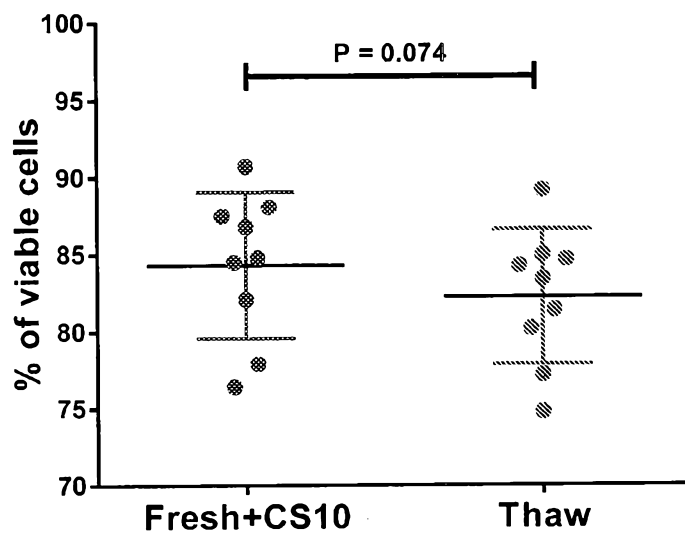
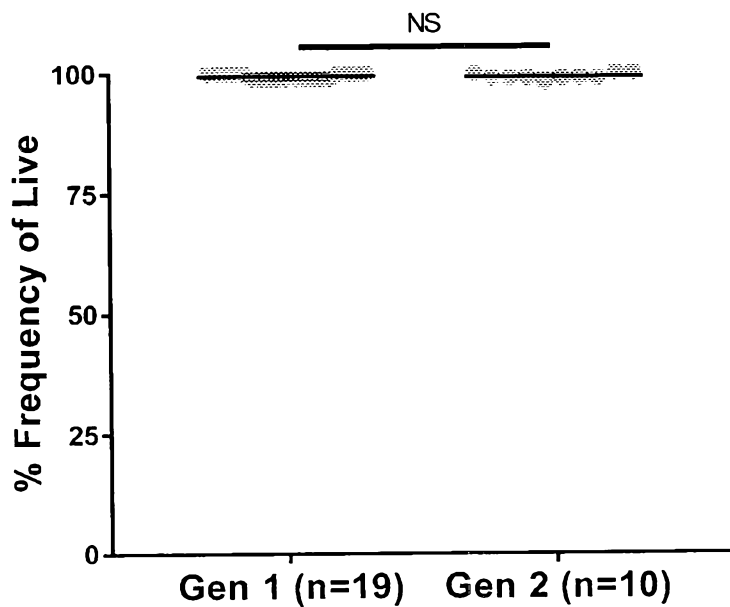

Figure 96A

%CD45 CD3: Gen 1 vs. Gen 2



106/136

Figure 96B

CD27 Expression: Gen1 vs. Gen2

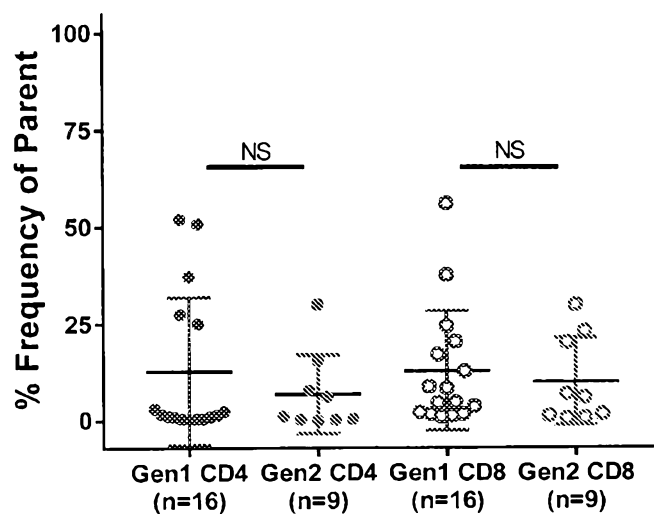
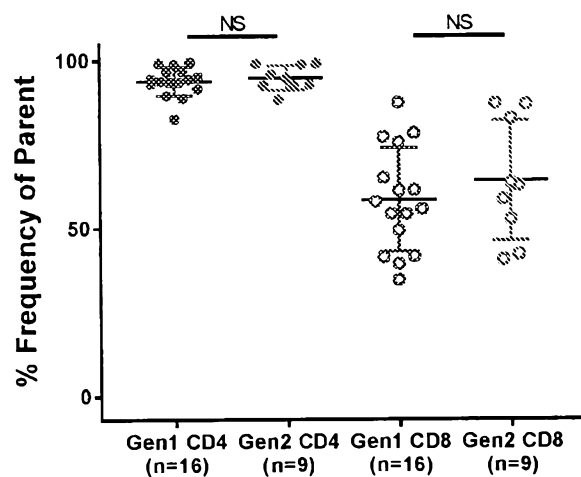

Figure 96C

CD28 Expression: Gen1 vs. Gen2



107/136

Figure 97

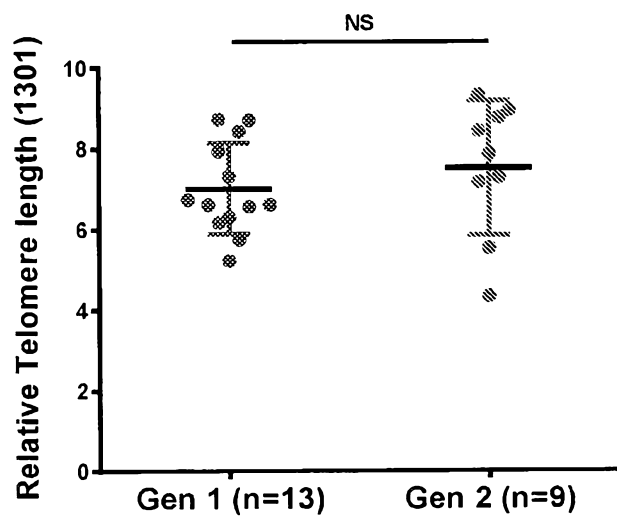
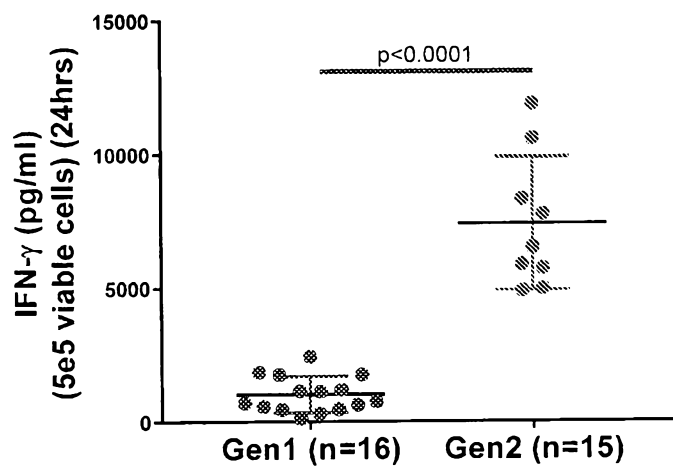

Figure 98



108/136

Figure 99A

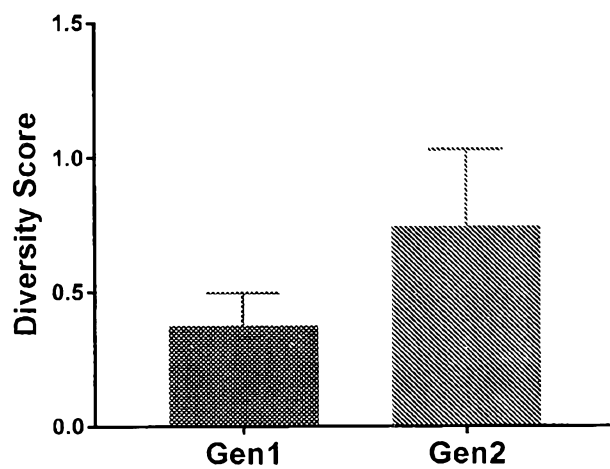

Figure 99B

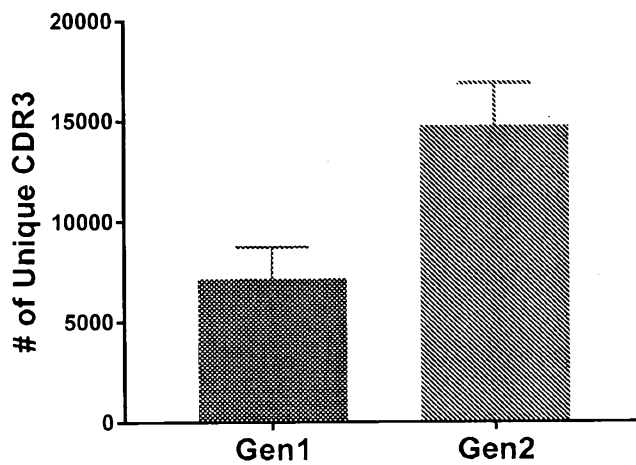

Figure 100

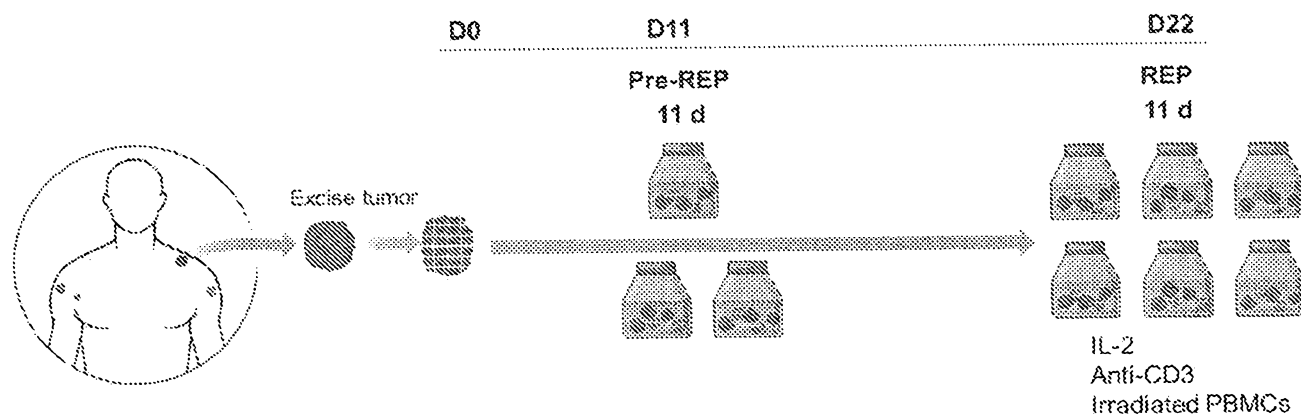

Figure 101

Tumor Histology	# of studies demonstrating >20% enhancement of growth using IL-2/IL-15/IL-21 (compared to IL-2)
Melanoma	1/5 (20%)
Lung	3/8 (38%)
Colorectal	7/11 (63%)
Cervical	1/1 (100%)
Pancreatic	2/2 (100%)
Glioblastoma	1/1 (100%)
Triple Negative Breast	1/2 (50%)

110/136

Figure 102A

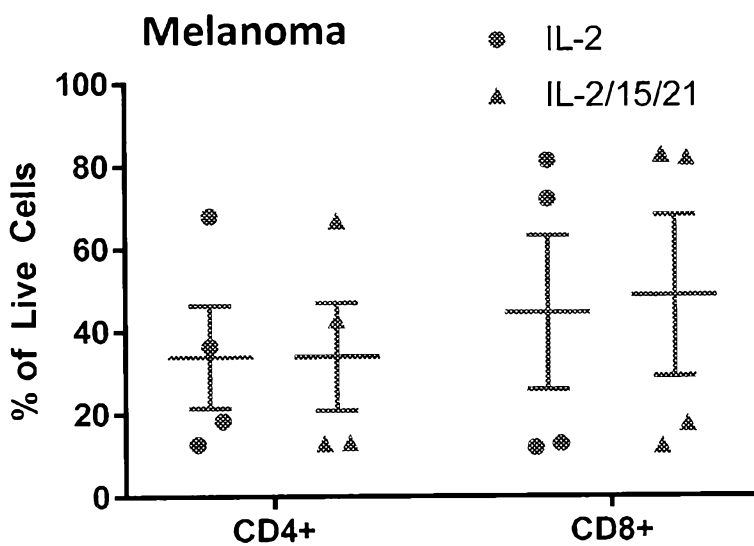
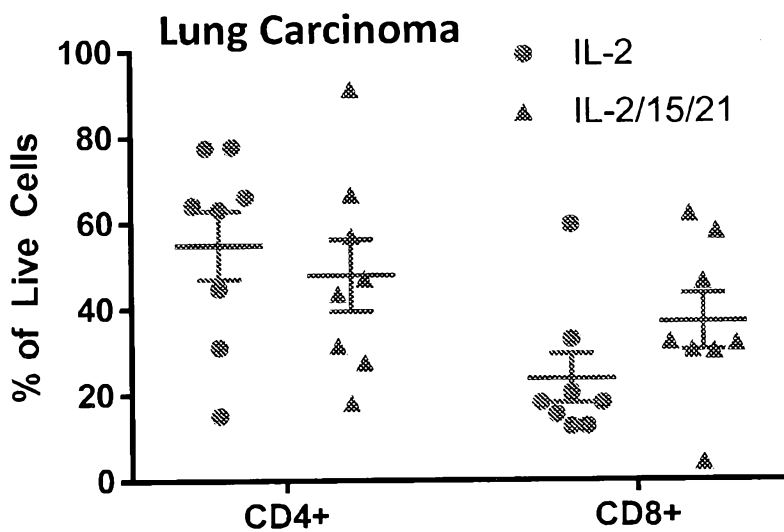

Figure 102B



111/136

Figure 103A

Melanoma

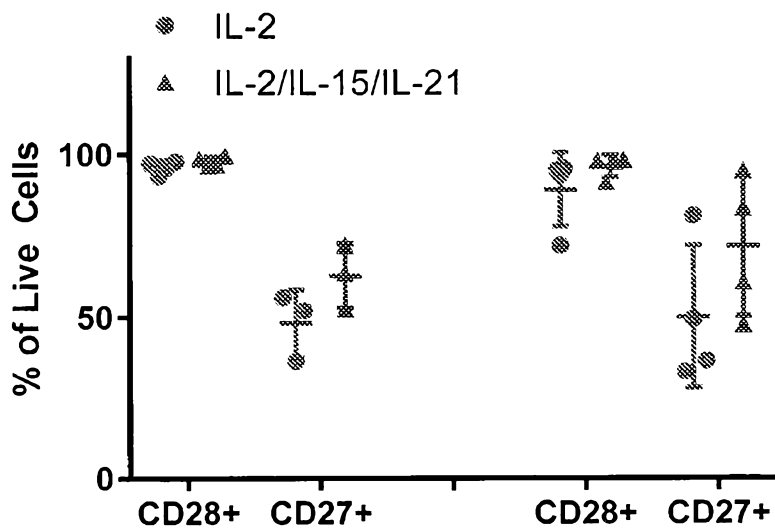
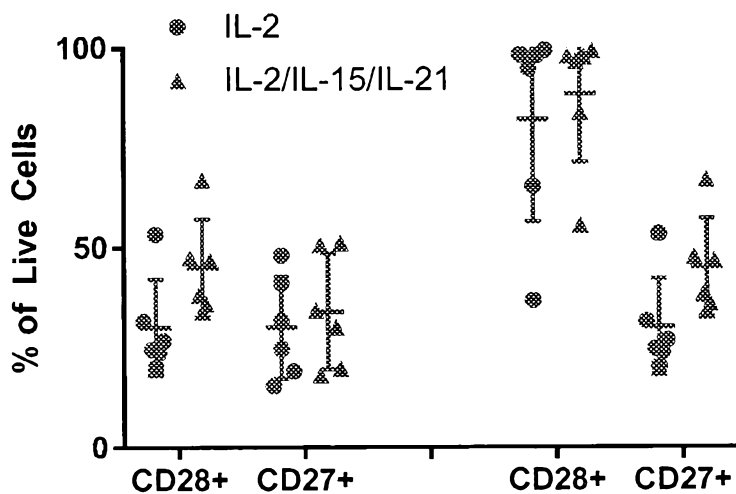

Figure 103B

Lung Carcinoma



112/136

Figure 104A

Melanoma

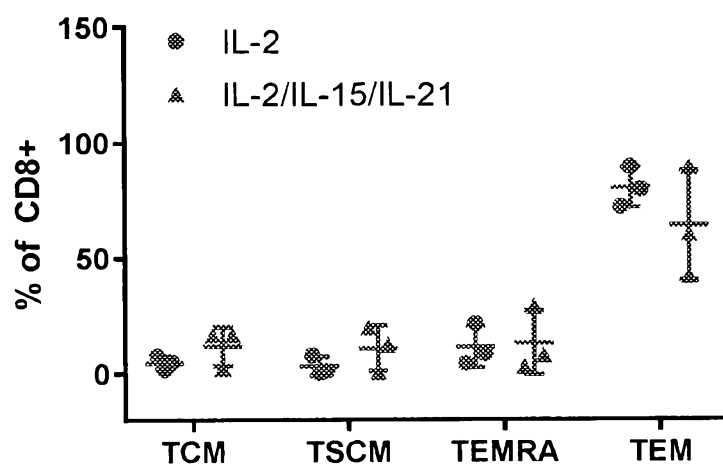
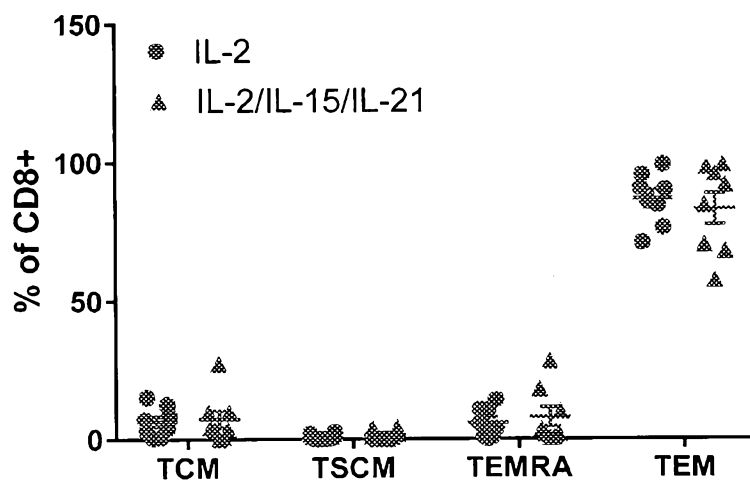

Figure 104B

Lung Carcinoma



113/136

Figure 105A

Melanoma

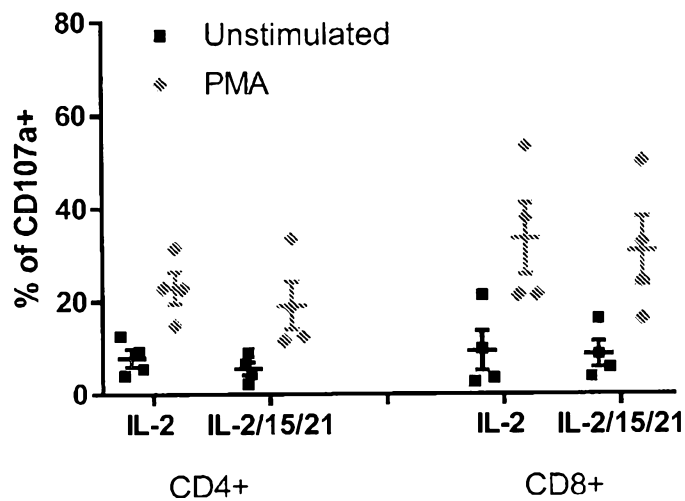

Figure 105B

Lung Carcinoma

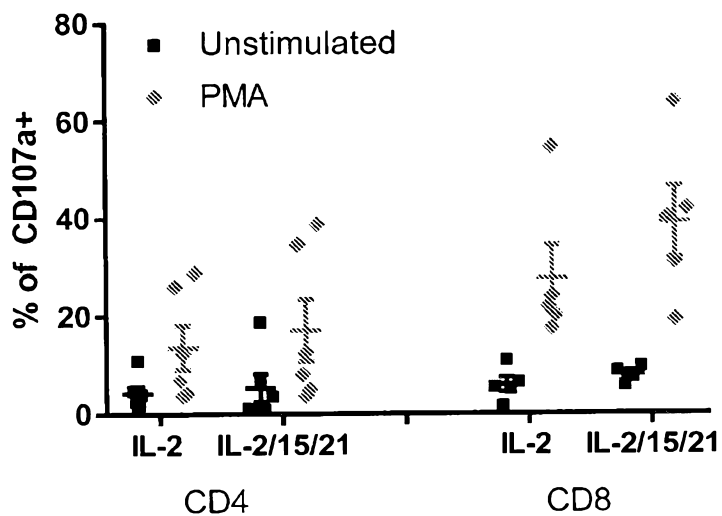
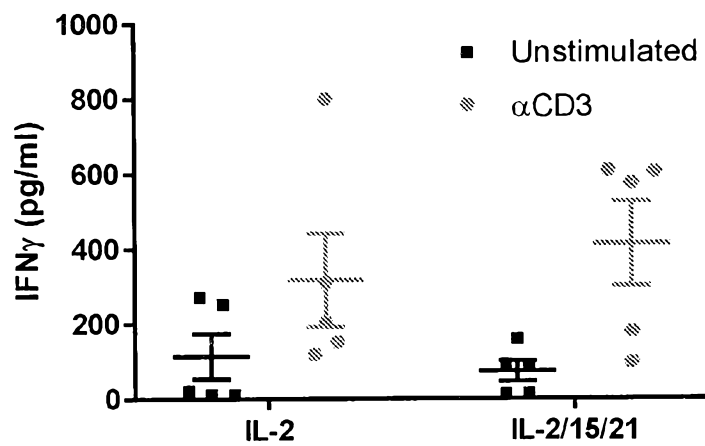

Figure 105C



115/136

Figure 106A

Melanoma

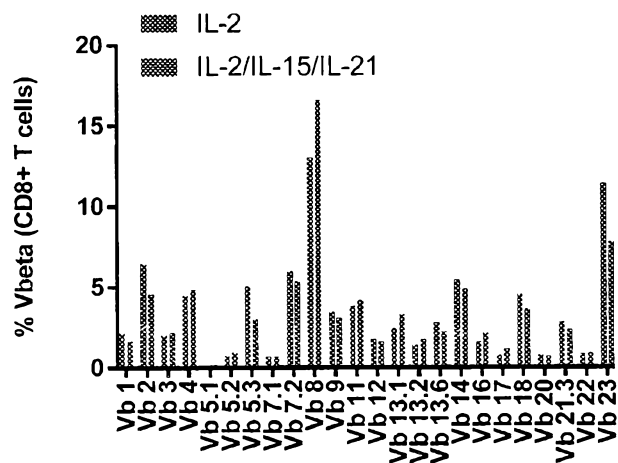

IL-2

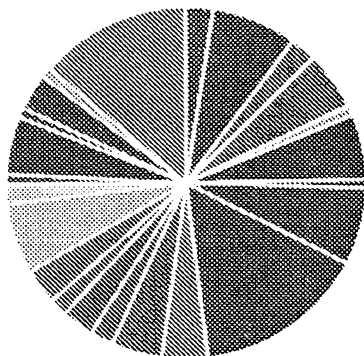

IL-2/IL-15/IL-21

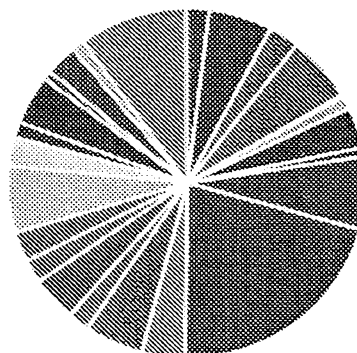

116/136

Figure 106B

Lung Carcinoma

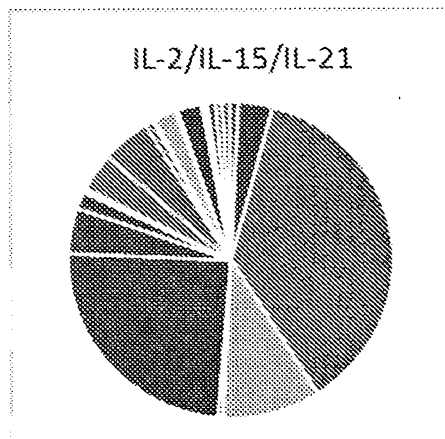
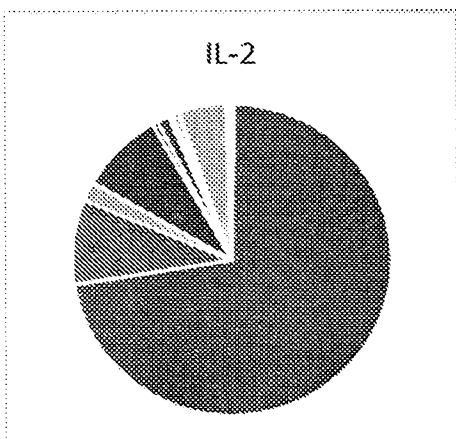
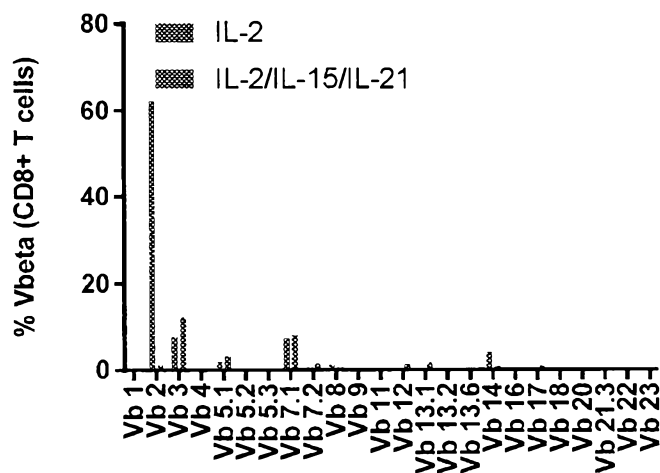

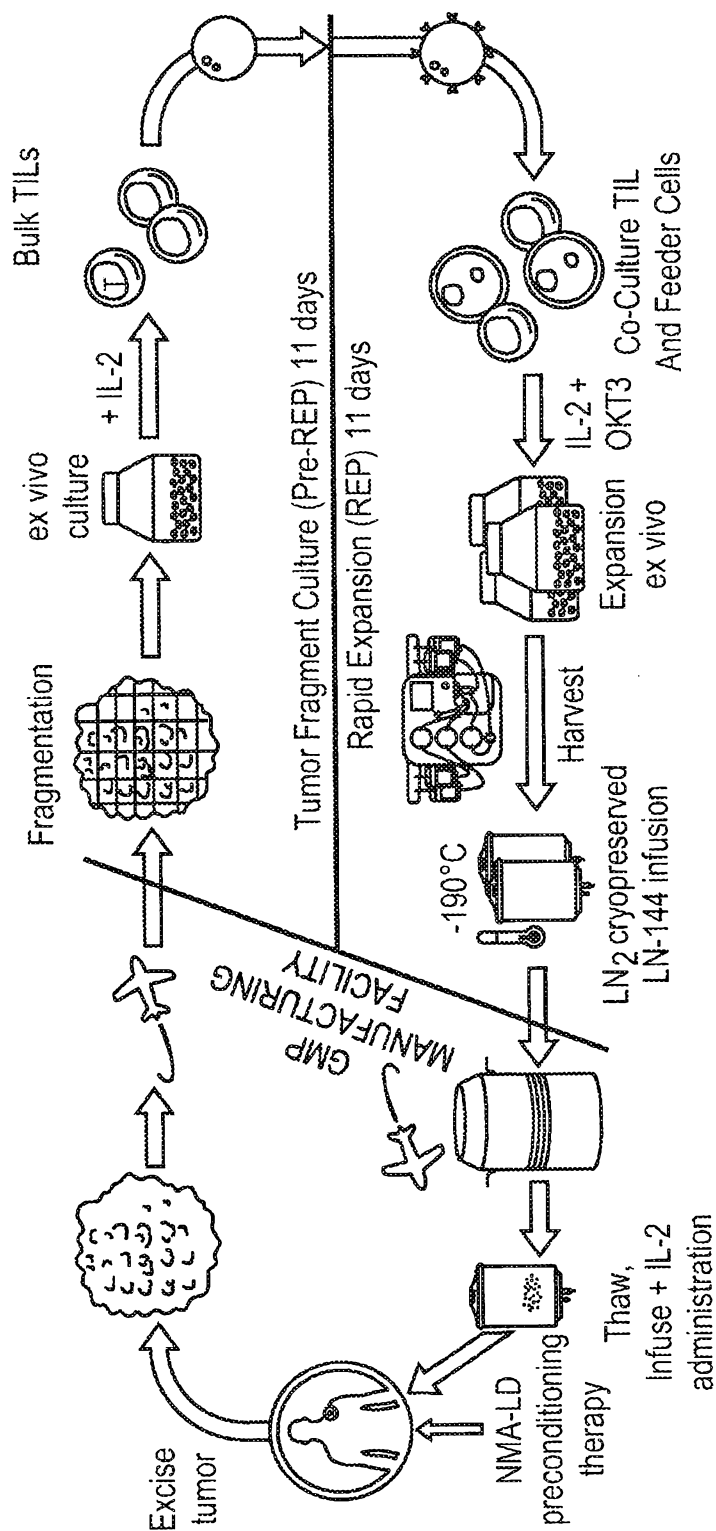
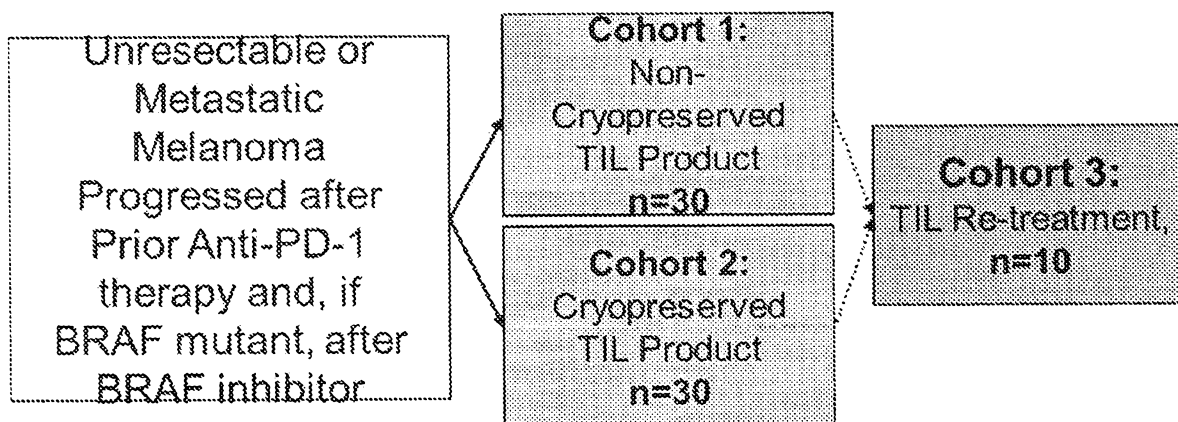

Figure 107

118/136

Figure 108



CHARACTERISTIC	Historical Cohort 1* N = 16, (%)	Cohort 2 N = 13, (%)
Gender, n (%)		
Male	7 (44)	5 (39)
Female	9 (56)	8 (62)
Age		
Median	55	54
Min, Max	41, 72	35, 66
Prior therapies, n (%)		
Mean # prior systemic therapies	3	4
Anti-CTLA-4	14 (88)	13 (100)
Anti-PD-1	21 (100)	13 (100)
Target Lesion Sum of Diameter (mm)		
Mean (SD)	104 (68)	141 (102)
Min, Max	15, 225	38, 342
CHARACTERISTIC	Historical Cohort 1* N = 16, (%)	Cohort 2 N = 13, (%)
Baseline ECOG score, n (%)		
0	9 (56)	8 (62)
1	7 (44)	5 (39)
BRAF Status, n (%)		
Mutated	9 (56)	6 (46)
Wild Type	7 (44)	7 (54)
Baseline LDH (U/L [SD])		
1-2 times ULN	7 (44)	7 (54)
Min, Max	1 (6)	2 (15)
Number of Target & Non-Target Lesions (at Base Line)		
>3	12(75)	10(77)
Mean	5.6	5.5

Figure 109

120/136

PREFERRED TERM	Historical Cohort 1 (N = 16)			Cohort 2 (N = 13)		
	Any Grade n (%)	Grade 3/4 n (%)	Grade 5 n (%)	Any Grade n (%)	Grade 3/4 n (%)	Grade 5 n (%)
Number of patients reporting at least one Treatment-Emergent AE	14 (87.5)	14 (87.5)	0	12 (85.7)	11 (78.6)	0
Nausea	14 (87.5)	0	0	7 (53.8)	0	0
Platelet count decreased	12 (75.0)	12 (75.0)	0	7 (53.8)	6 (46.2)	0
Anaemia	11 (68.8)	8 (50.0)	0	8 (61.5)	7 (53.8)	0
Neutrophil count decreased	11 (68.8)	11 (68.8)	0	6 (46.2)	6 (46.2)	0
Febril neutropenia	10 (62.5)	10 (62.5)	0	7 (53.8)	6 (46.2)	0
White blood count decreased	10 (62.5)	10 (62.5)	0	6 (46.2)	6 (46.2)	0
Chills	9 (56.3)	0	0	6 (46.2)	1 (7.7)	0
Diarrhoea	8 (50.0)	1 (6.3)	0	4 (30.8)	0	0
Fatigue	7 (43.8)	0	0	7 (53.8)	0	0
Vomiting	7 (43.8)	0	0	2 (15.4)	0	0
Constipation	6 (37.5)	0	0	3 (23.1)	0	0
Decreased appetite	5 (31.3)	0	0	4 (30.8)	0	0
Headache	5 (31.3)	0	0	3 (23.1)	0	0
Hypocalcaemia	5 (31.3)	0	0	1 (7.7)	0	0
Hypokalaemia	5 (31.3)	0	0	3 (23.1)	0	0
Hypophosphataemia	5 (31.3)	5 (31.3)	0	4 (23.1)	1 (7.7)	0
Hypotension	5 (31.3)	2 (12.5)	0	3 (23.1)	3 (7.7)	0
Lymphocyte count decreased	5 (31.3)	5 (31.3)	0	3 (23.1)	3 (23.1)	0
Nasal Congestion	5 (31.3)	0	0	0	0	0
Pyrexia	5 (31.3)	0	0	9 (69.2)	1 (7.7)	0
Cough	4 (25.0)	0	0	4 (30.8)	0	0
Oedema peripheral	4 (25.0)	0	0	4 (30.8)	0	0
Pruritus	4 (25.0)	0	0	4 (30.8)	0	0

Notes: Adverse events are coded by MedDRA version 18.1.

Patients with multiple events for a given preferred term are counted only once using the maximum grade under each preferred term.

Events are sorted by decreasing frequency of preferred term under SOC per any grade.

Treatment-Emergent Adverse Events refer to all AEs starting on or after the first dose date of pre-treatment chemotherapy(Fludarabine and Cyclophosphamide) up to the last dose of IL2 + 30 days.

*Figure 110*

121/136

Figure 111

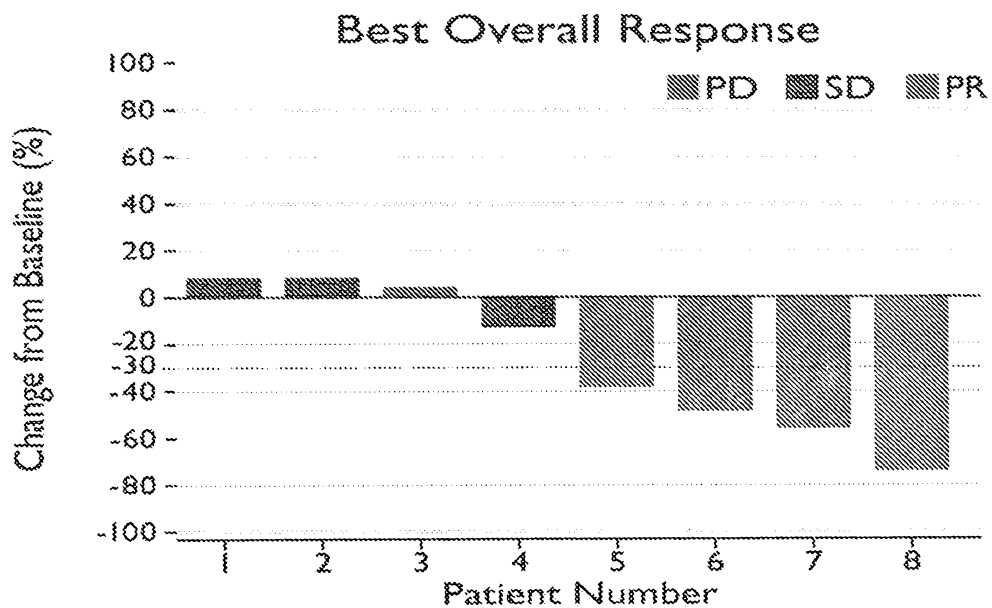
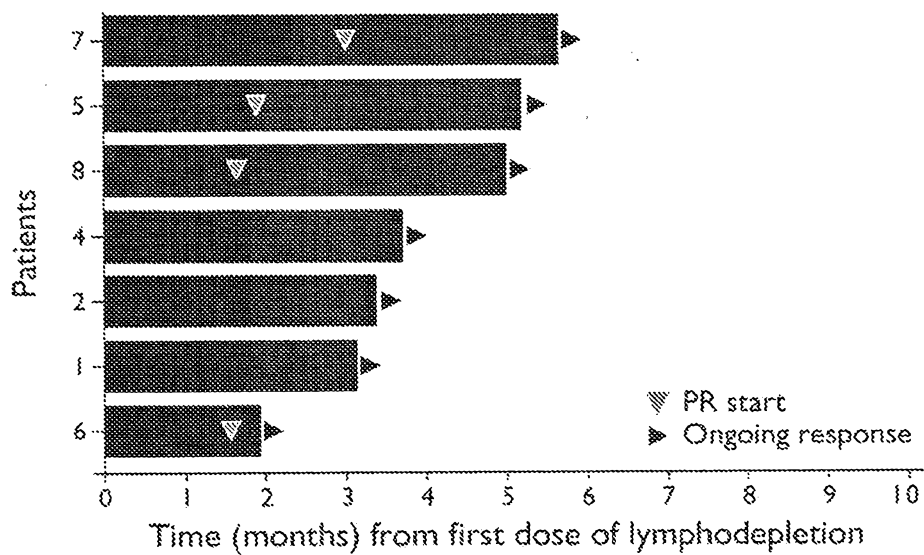

Figure 112



122/136

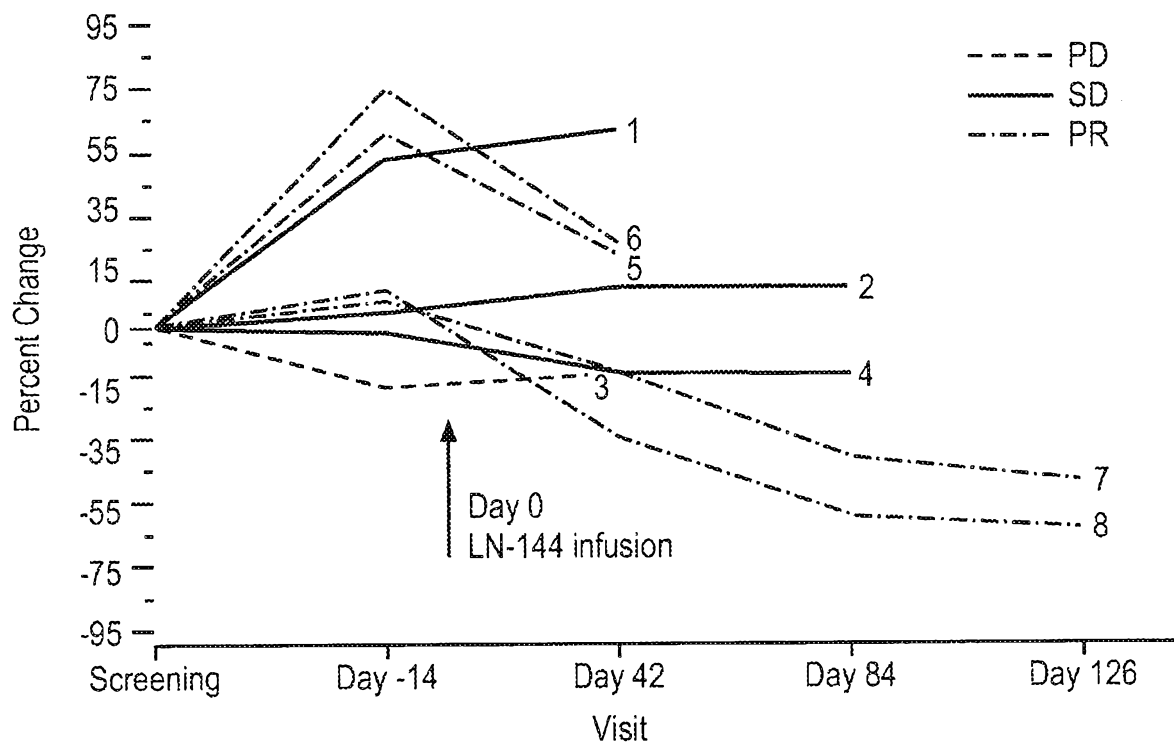

Figure 113

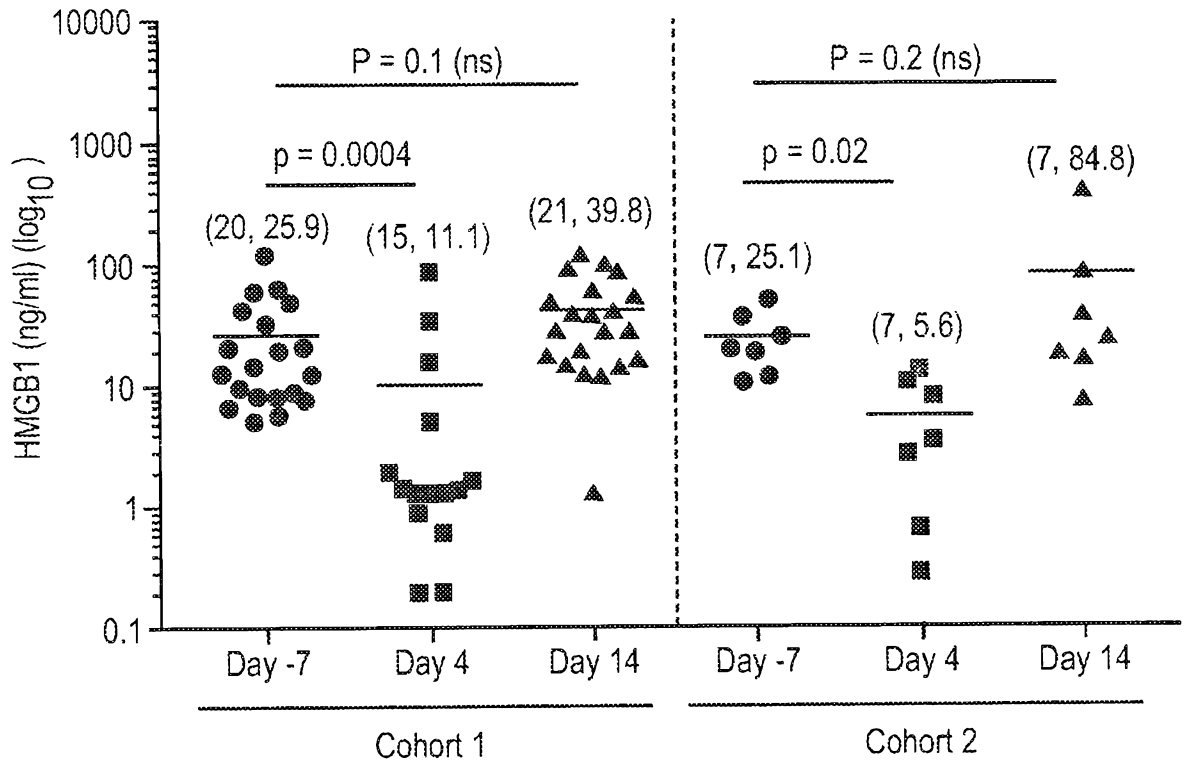

Figure 114

124/136

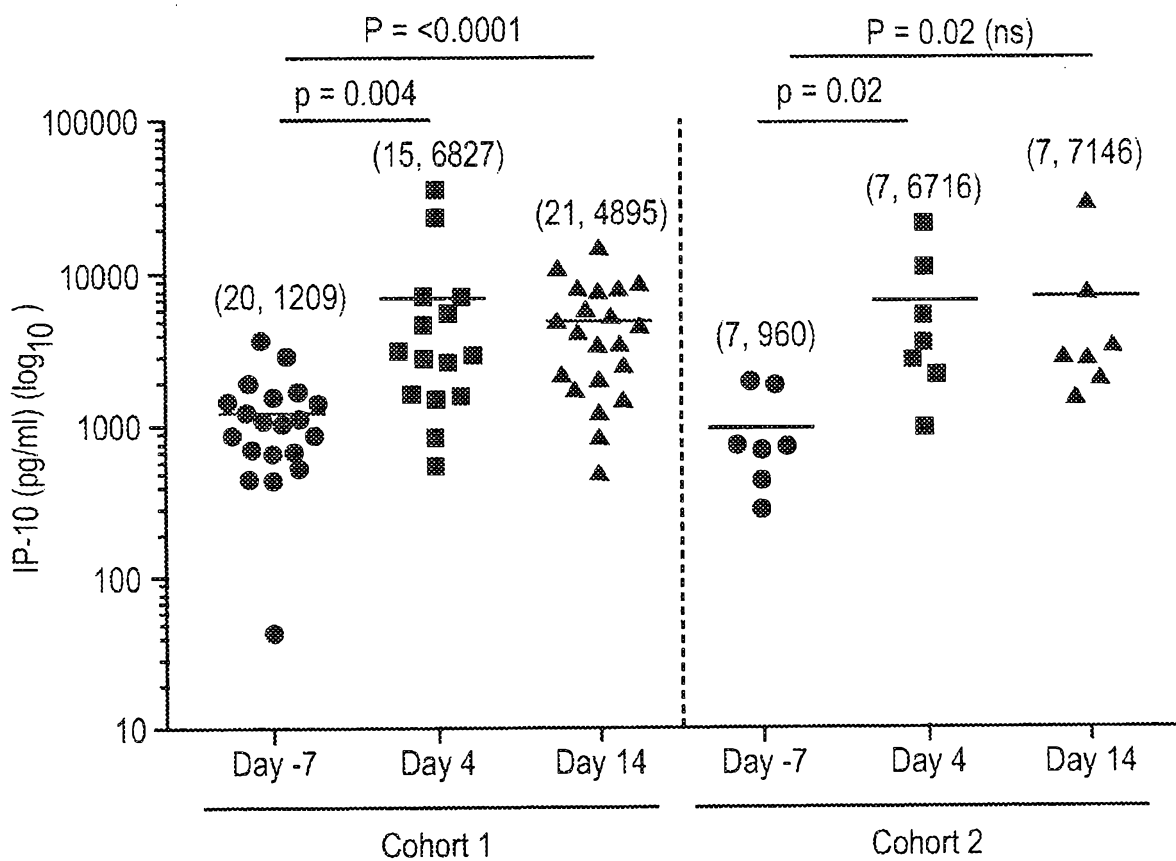

Figure 115

CHARACTERISTIC	Cohort 2 N = 17, (%)
Gender, n (%)	
Male	8 (47)
Female	9 (53)
Age	
Median	54
Min, Max	35, 66
Prior therapies, n (%)	
Mean # prior systemic therapies	3.6
Anti-CTLA-4	15 (88)
Anti-PD-1	16 (94)
Target Lesion Sum of Diameter (mm)	
Mean (SD)	140 (93)
Min, Max	38, 342
CHARACTERISTIC	Cohort 2 N = 17, (%)
Baseline ECOG, n (%)	
0	11 (65)
1	6 (35)
BRAF Status, n (%)	
Mutated	5 (29)
Wild Type	9 (53)
Unknown	3 (18)
Baseline LDH (U/L [SD])	
1-2 times ULN	8 (47)
> 2 times ULN	2 (12)
Number of Target & Non-Target Lesions (at Base Line)	
> 3	12 (71)
Mean	5.9

Cohort 2 has:

3.6 median prior therapies

High tumor burden at baseline as reflected by 140 mm sum of diameters for target lesions

*Figure 116*

PREFERRED TERM	Cohort 2 (N = 17)		
	Any Grade n (%)	Grade 3/4 n (%)	Grade 5 n (%)
Number of patients reporting at least one Treatment-Emergent AE	16 (94.1)	16 (94.1)	0
Pyrexia	13 (76.5)	1 (5.9)	0
Anaemia	11 (64.7)	10 (58.8)	0
Neutrophil count decreased	10 (58.8)	10 (58.8)	0
Platelet count decreased	10 (58.8)	8 (47.1)	0
Febrile neutropenia	10 (58.8)	8 (47.1)	0
Fatigue	10 (58.8)	0	0
Chills	9 (52.9)	1 (5.9)	0
Nausea	9 (52.9)	0	0
White blood cell count decreased	8 (47.1)	8 (47.1)	0
Lymphocyte count decreased	6 (35.3)	6 (35.3)	0
Diarroea	6 (35.3)	0	0
Decreased appetite	6 (35.3)	0	0

Notes: Patients with multiple events for a given preferred term are counted only once using the maximum grade under each preferred term. Treatment-Emergent Adverse Events refer to all AEs starting on or after the first dose date of pre-treatment chemotherapy (Fludarabine and Cyclophosphamide) up to the last dose of IL-2 + 30 days.

*Figure 117*

Figure 118

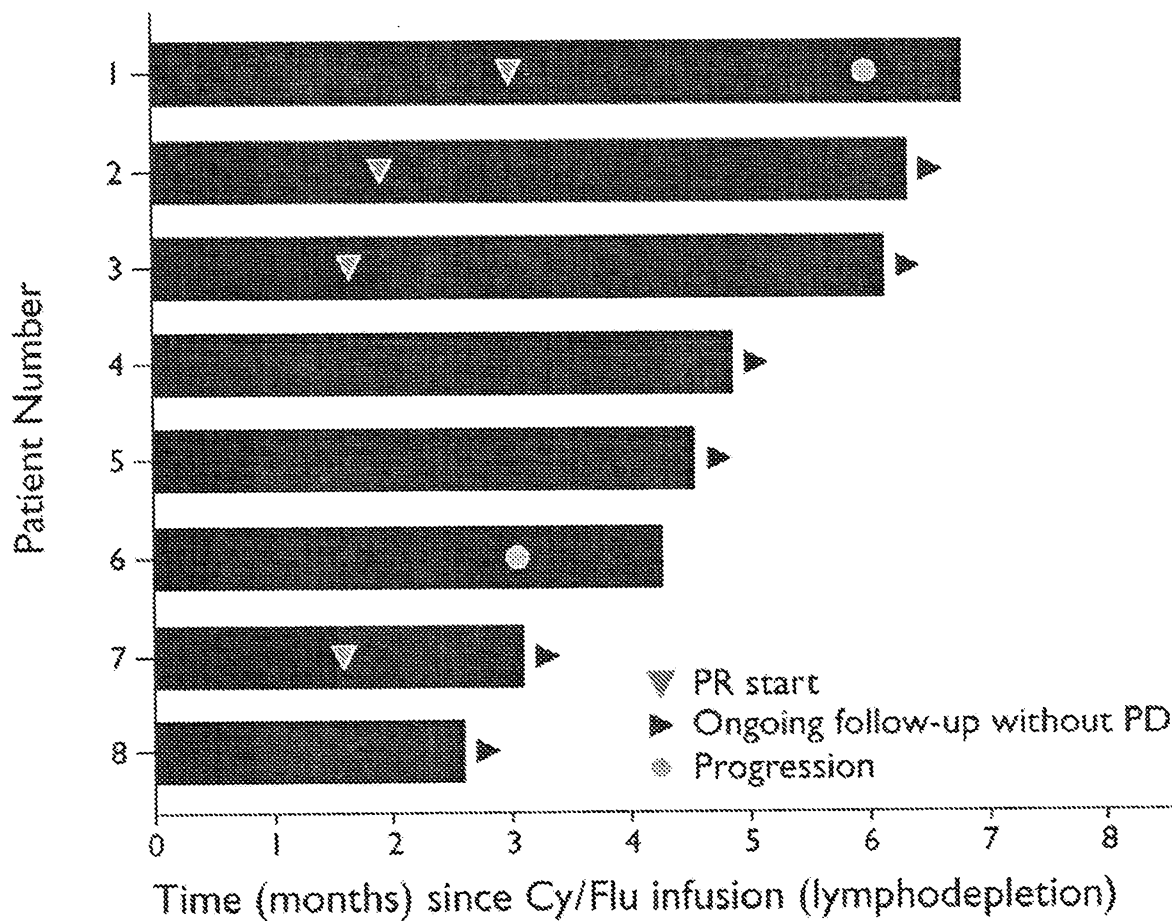
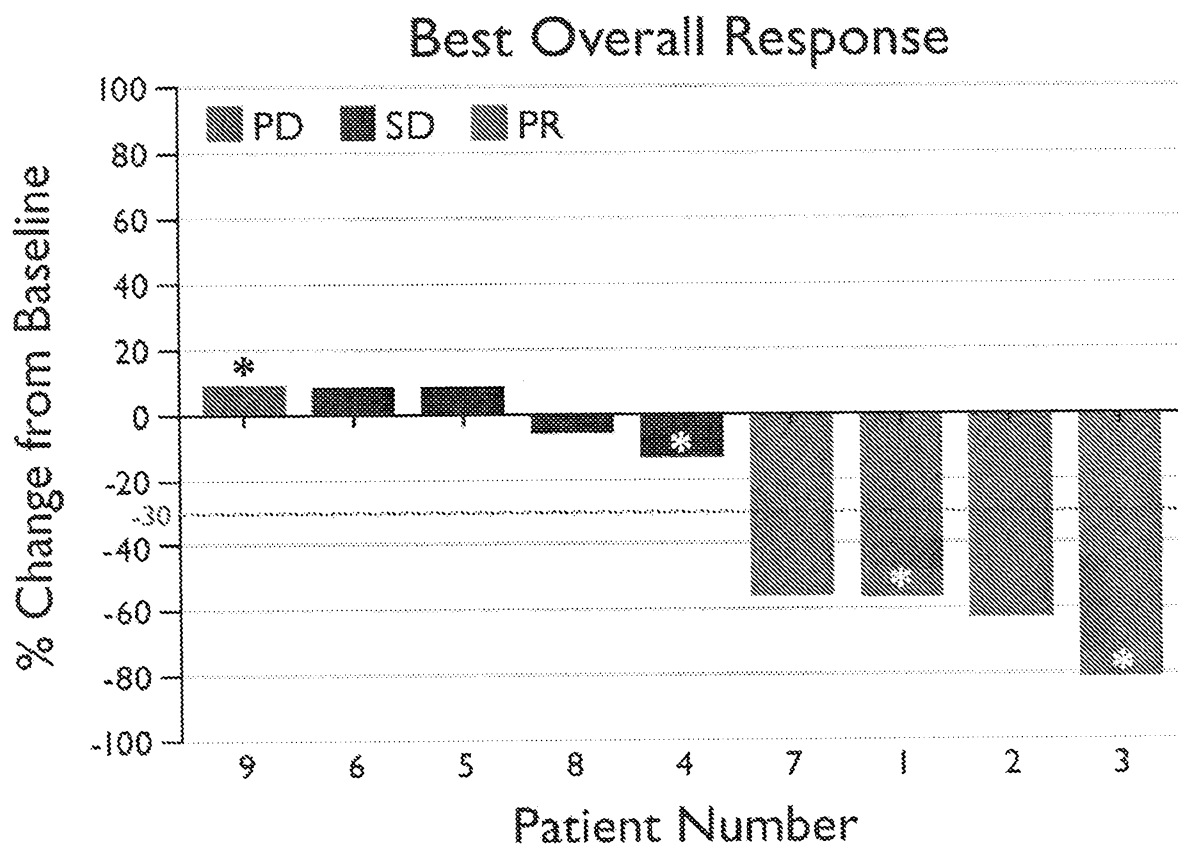

Figure 119



129/136

*Figure 120*

RESPONSE	PATIENTS, N=10 n (%)
<b>Objective Response Rate</b>	<b>4 (40%)</b>
Disease Control Rate	8 (80%)
Partial Response	4 (40%)
Stable Disease	4 (40%)
Progressive Disease	1 (10%)
Non-Evaluable*	1 (10%)

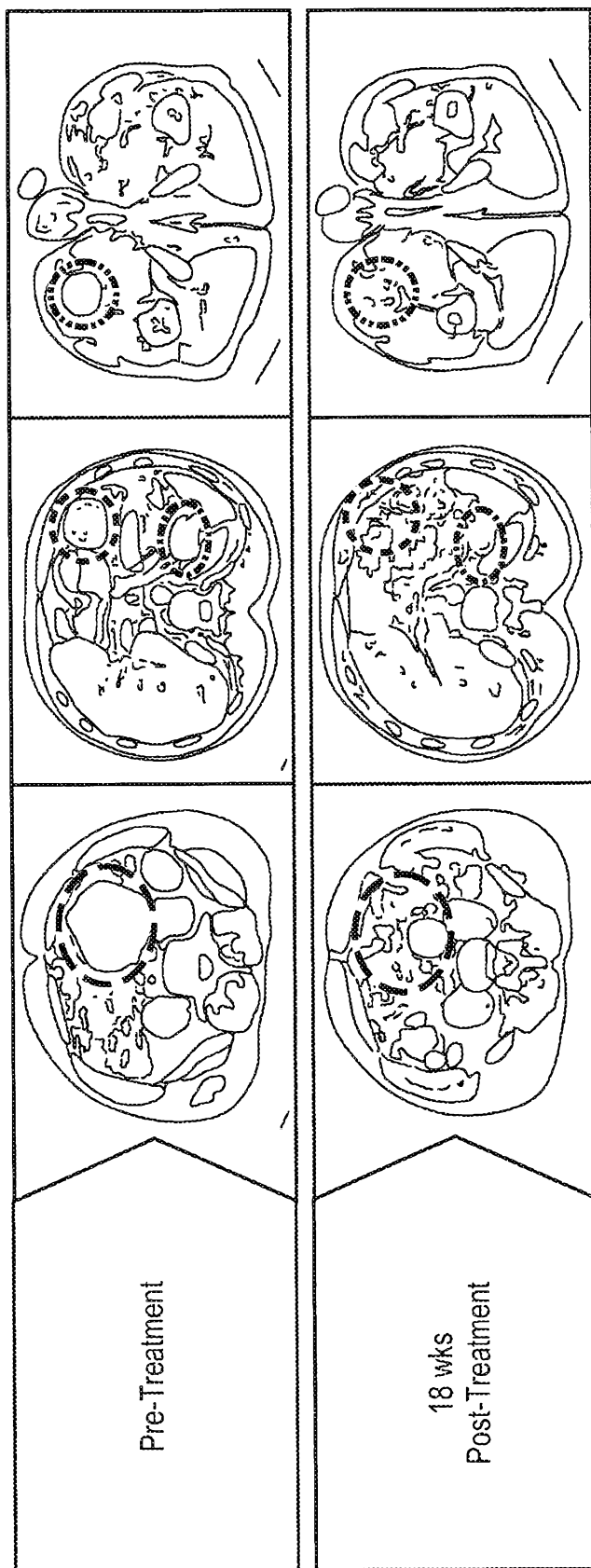
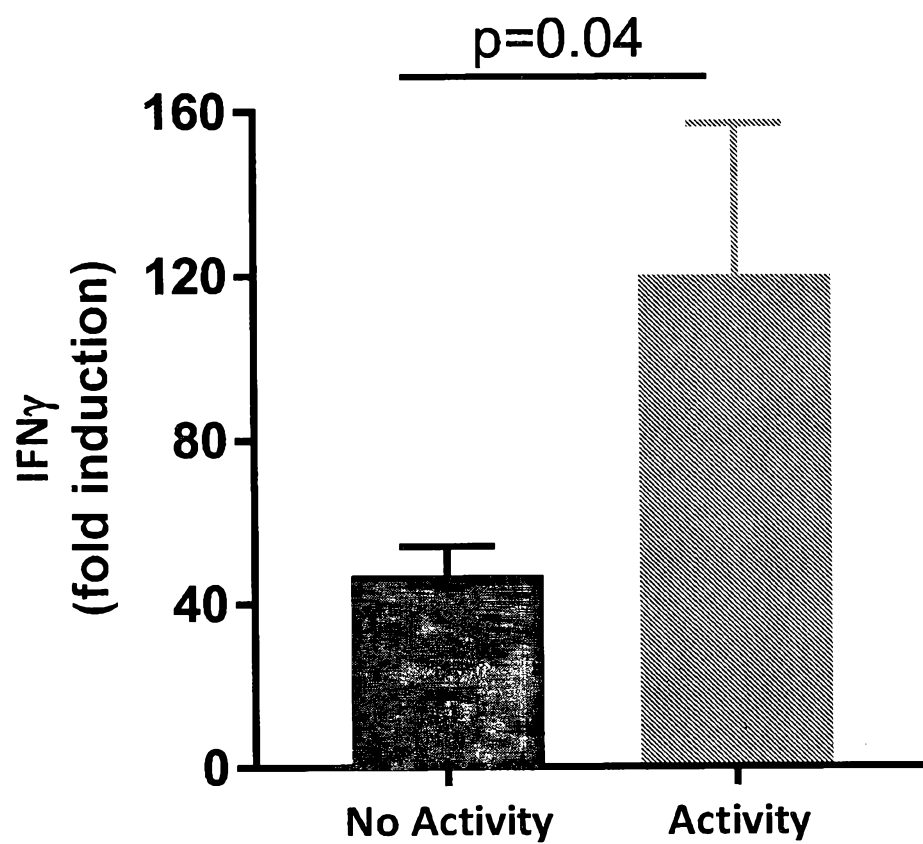

Figure 121

131/136

Figure 122



132/136

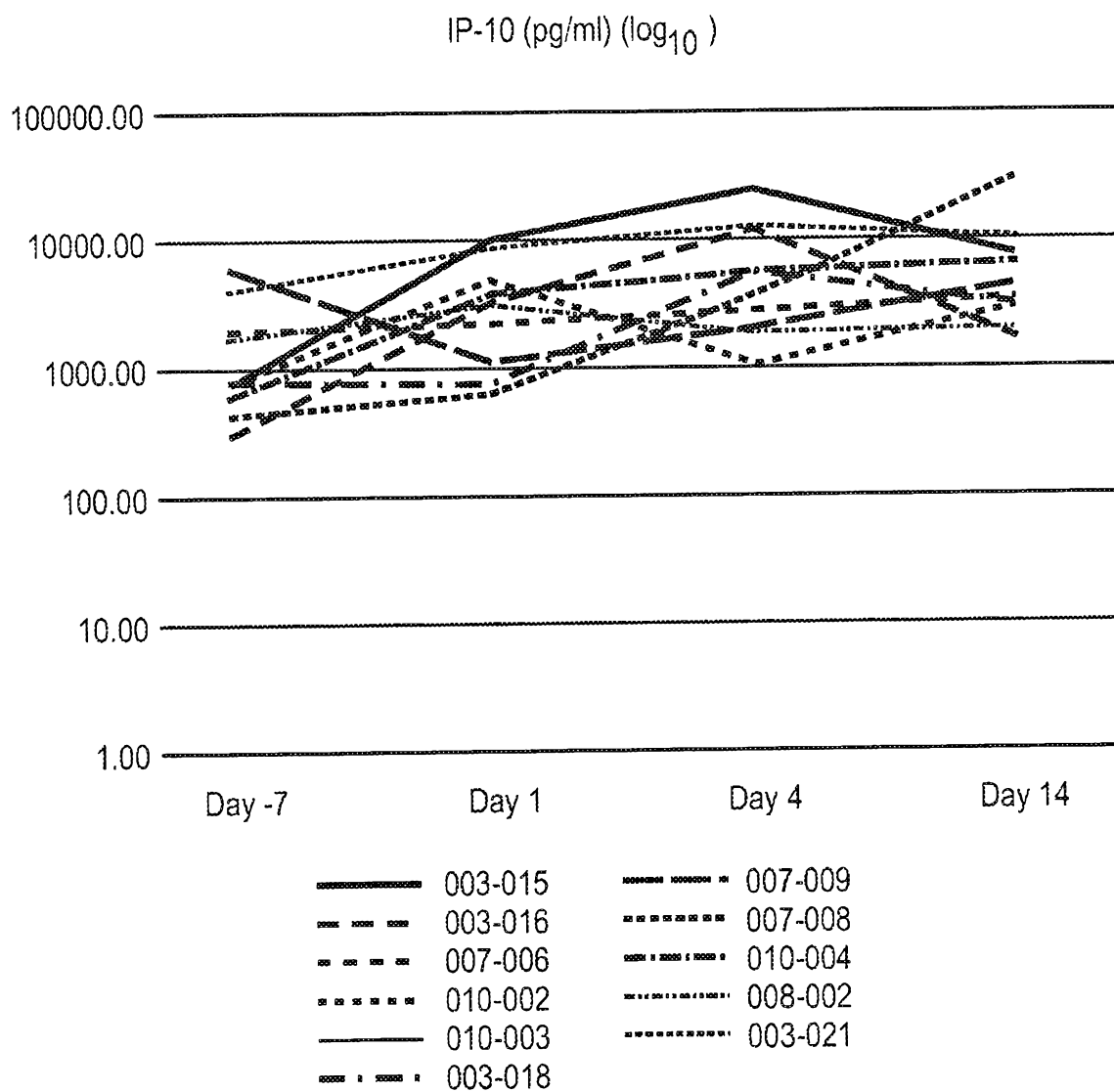

Figure 123

133/136

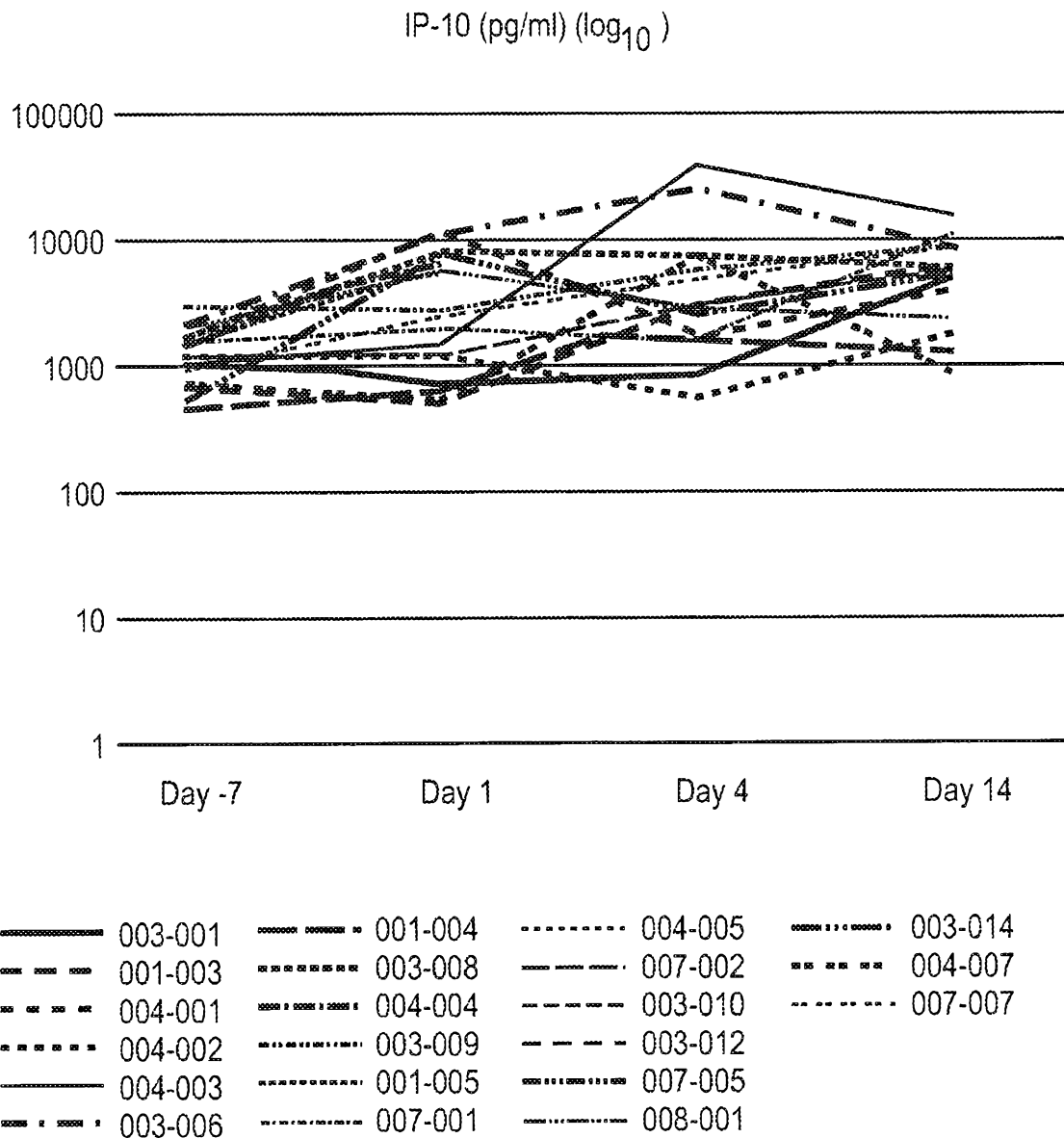

Figure 124

134/136

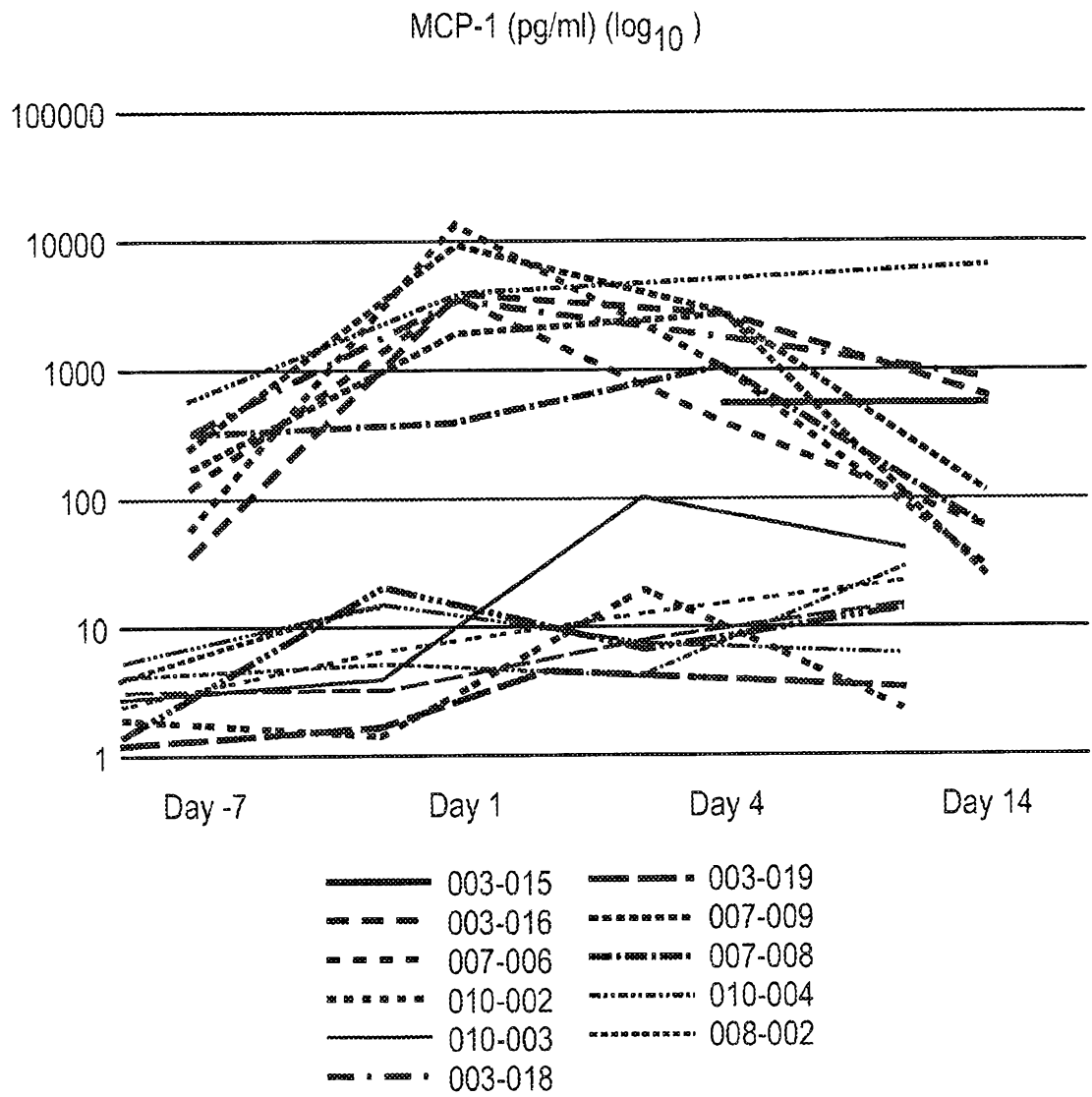

Figure 125

135/136

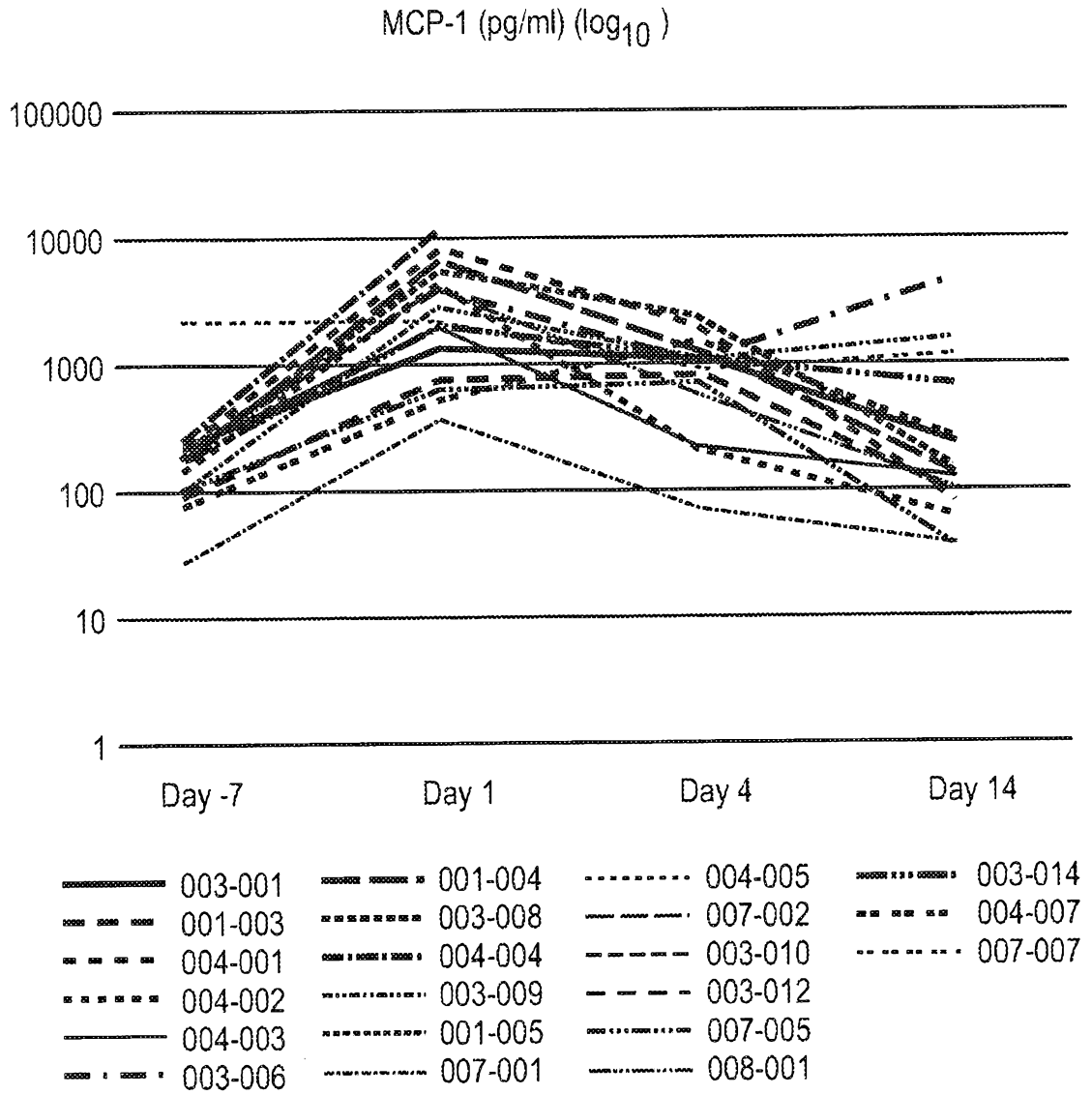

Figure 126

Cervical Carcinoma (C-145-04)									
Pt No	INFUSION	# CELLS INFUSED	RESPONSE DAY 42	RESPONSE DAY 84	RESPONSE DAY 126	RESPONSE AT 6 MONTHS	RESPONSE AT 9 MONTHS	BOR	
1	9-Aug-17	32.6 bil	PR	PR	-	-	-	-	
2	19-Sep-17	41.4 bil	SD (needs confirmation)			-	-	-	
HNSCC (C-145-03)									
Pt No	INFUSION	# CELLS INFUSED	RESPONSE DAY 28	RESPONSE DAY 56	RESPONSE DAY 84	RESPONSE AT 4 MONTHS	RESPONSE AT 6 MONTHS	BOR	
1	31-May-17	21 bil	SD	PD	Discon.	-	-	SD	
2	20-Jun-17	21 bil	PR	SD	SD	Passed away.	-	SD	
3	1-Aug-17	30 bil	PR	PR	PR	PD	-	PR	
4	14-Sep-17	65 bil	PR	PR	-	-	-	PR	
5	03-Nov-17	10 bil	-	-	-	-	-	-	
6	07-Nov-17	37 bil	-	-	-	-	-	-	
7	08-Nov-17	21.5 bil	-	-	-	-	-	-	

Median Prior therapies for HNSCC: 4, all have had poor anti-PD-1. The data is live and subject to change.

Figure 127

## SEQUENCE LISTING

<110> IOVANCE BIOTHERAPEUTICS, INC.  
 Bender, James  
 Wardell, Seth  
 Lotze, Michael T.

<120> PROCESSES FOR PRODUCTION OF TUMOR INFILTRATING LYMPHOCYTES AND  
 USES OF SAME IN IMMUNOTHERAPY

<130> 116983-5017

<150> 62/478,506  
 <151> 2017-03-29

<150> 62/539,410  
 <151> 2017-07-31

<150> 62/548,306  
 <151> 2017-08-21

<150> 62/554,538  
 <151> 2017-09-05

<150> 62/559,374  
 <151> 2017-09-15

<150> 62/567,121  
 <151> 2017-10-02

<150> 62/577,655  
 <151> 2017-10-26

<150> 62/582,874  
 <151> 2017-11-07

<150> 62/596,374  
 <151> 2017-12-08

<160> 8

<170> PatentIn version 3.5

<210> 1  
 <211> 450  
 <212> PRT  
 <213> Artificial Sequence

<220>  
 <223> Muromonab heavy chain

<400> 1

Gln Val Gln Leu Gln Gln Ser Gly Ala Glu Leu Ala Arg Pro Gly Ala  
 1                    5                    10                    15

Ser Val Lys Met Ser Cys Lys Ala Ser Gly Tyr Thr Phe Thr Arg Tyr



Ser Arg Thr Pro Glu Val Thr Cys Val Val Val Asp Val Ser His Glu  
260 265 270

Asp Pro Glu Val Lys Phe Asn Trp Tyr Val Asp Gly Val Glu Val His  
275 280 285

Asn Ala Lys Thr Lys Pro Arg Glu Glu Gln Tyr Asn Ser Thr Tyr Arg  
290 295 300

Val Val Ser Val Leu Thr Val Leu His Gln Asp Trp Leu Asn Gly Lys  
305 310 315 320

Glu Tyr Lys Cys Lys Val Ser Asn Lys Ala Leu Pro Ala Pro Ile Glu  
325 330 335

Lys Thr Ile Ser Lys Ala Lys Gly Gln Pro Arg Glu Pro Gln Val Tyr  
340 345 350

Thr Leu Pro Pro Ser Arg Asp Glu Leu Thr Lys Asn Gln Val Ser Leu  
355 360 365

Thr Cys Leu Val Lys Gly Phe Tyr Pro Ser Asp Ile Ala Val Glu Trp  
370 375 380

Glu Ser Asn Gly Gln Pro Glu Asn Asn Tyr Lys Thr Thr Pro Pro Val  
385 390 395 400

Leu Asp Ser Asp Gly Ser Phe Phe Leu Tyr Ser Lys Leu Thr Val Asp  
405 410 415

Lys Ser Arg Trp Gln Gln Gly Asn Val Phe Ser Cys Ser Val Met His  
420 425 430

Glu Ala Leu His Asn His Tyr Thr Gln Lys Ser Leu Ser Leu Ser Pro  
435 440 445

Gly Lys  
450

<210> 2

<211> 213

<212> PRT

<213> Artificial Sequence

&lt;220&gt;

&lt;223&gt; Muromonab light chain

&lt;400&gt; 2

Gln Ile Val Leu Thr Gln Ser Pro Ala Ile Met Ser Ala Ser Pro Gly  
 1 5 10 15

Glu Lys Val Thr Met Thr Cys Ser Ala Ser Ser Ser Val Ser Tyr Met  
 20 25 30

Asn Trp Tyr Gln Gln Lys Ser Gly Thr Ser Pro Lys Arg Trp Ile Tyr  
 35 40 45

Asp Thr Ser Lys Leu Ala Ser Gly Val Pro Ala His Phe Arg Gly Ser  
 50 55 60

Gly Ser Gly Thr Ser Tyr Ser Leu Thr Ile Ser Gly Met Glu Ala Glu  
 65 70 75 80

Asp Ala Ala Thr Tyr Tyr Cys Gln Gln Trp Ser Ser Asn Pro Phe Thr  
 85 90 95

Phe Gly Ser Gly Thr Lys Leu Glu Ile Asn Arg Ala Asp Thr Ala Pro  
 100 105 110

Thr Val Ser Ile Phe Pro Pro Ser Ser Glu Gln Leu Thr Ser Gly Gly  
 115 120 125

Ala Ser Val Val Cys Phe Leu Asn Asn Phe Tyr Pro Lys Asp Ile Asn  
 130 135 140

Val Lys Trp Lys Ile Asp Gly Ser Glu Arg Gln Asn Gly Val Leu Asn  
 145 150 155 160

Ser Trp Thr Asp Gln Asp Ser Lys Asp Ser Thr Tyr Ser Met Ser Ser  
 165 170 175

Thr Leu Thr Leu Thr Lys Asp Glu Tyr Glu Arg His Asn Ser Tyr Thr  
 180 185 190

Cys Glu Ala Thr His Lys Thr Ser Thr Ser Pro Ile Val Lys Ser Phe  
 195 200 205

Asn Arg Asn Glu Cys

210

<210> 3  
 <211> 134  
 <212> PRT  
 <213> Artificial Sequence

<220>  
 <223> recombinant human IL-2 (rhIL-2)

<400> 3

Met Ala Pro Thr Ser Ser Ser Thr Lys Lys Thr Gln Leu Gln Leu Glu  
 1 5 10 15

His Leu Leu Leu Asp Leu Gln Met Ile Leu Asn Gly Ile Asn Asn Tyr  
 20 25 30

Lys Asn Pro Lys Leu Thr Arg Met Leu Thr Phe Lys Phe Tyr Met Pro  
 35 40 45

Lys Lys Ala Thr Glu Leu Lys His Leu Gln Cys Leu Glu Glu Glu Leu  
 50 55 60

Lys Pro Leu Glu Glu Val Leu Asn Leu Ala Gln Ser Lys Asn Phe His  
 65 70 75 80

Leu Arg Pro Arg Asp Leu Ile Ser Asn Ile Asn Val Ile Val Leu Glu  
 85 90 95

Leu Lys Gly Ser Glu Thr Thr Phe Met Cys Glu Tyr Ala Asp Glu Thr  
 100 105 110

Ala Thr Ile Val Glu Phe Leu Asn Arg Trp Ile Thr Phe Cys Gln Ser  
 115 120 125

Ile Ile Ser Thr Leu Thr  
 130

<210> 4  
 <211> 132  
 <212> PRT  
 <213> Artificial Sequence

<220>  
 <223> Aldesleukin

<400> 4

Pro Thr Ser Ser Ser Thr Lys Lys Thr Gln Leu Gln Leu Glu His Leu  
1 5 10 15

Leu Leu Asp Leu Gln Met Ile Leu Asn Gly Ile Asn Asn Tyr Lys Asn  
20 25 30

Pro Lys Leu Thr Arg Met Leu Thr Phe Lys Phe Tyr Met Pro Lys Lys  
35 40 45

Ala Thr Glu Leu Lys His Leu Gln Cys Leu Glu Glu Glu Leu Lys Pro  
50 55 60

Leu Glu Glu Val Leu Asn Leu Ala Gln Ser Lys Asn Phe His Leu Arg  
65 70 75 80

Pro Arg Asp Leu Ile Ser Asn Ile Asn Val Ile Val Leu Glu Leu Lys  
85 90 95

Gly Ser Glu Thr Thr Phe Met Cys Glu Tyr Ala Asp Glu Thr Ala Thr  
100 105 110

Ile Val Glu Phe Leu Asn Arg Trp Ile Thr Phe Ser Gln Ser Ile Ile  
115 120 125

Ser Thr Leu Thr  
130

<210> 5

<211> 130

<212> PRT

<213> Artificial Sequence

<220>

<223> recombinant human IL-4 (rhIL-4)

<400> 5

Met His Lys Cys Asp Ile Thr Leu Gln Glu Ile Ile Lys Thr Leu Asn  
1 5 10 15

Ser Leu Thr Glu Gln Lys Thr Leu Cys Thr Glu Leu Thr Val Thr Asp  
20 25 30

Ile Phe Ala Ala Ser Lys Asn Thr Thr Glu Lys Glu Thr Phe Cys Arg  
35 40 45

Ala Ala Thr Val Leu Arg Gln Phe Tyr Ser His His Glu Lys Asp Thr  
 50 55 60

Arg Cys Leu Gly Ala Thr Ala Gln Gln Phe His Arg His Lys Gln Leu  
 65 70 75 80

Ile Arg Phe Leu Lys Arg Leu Asp Arg Asn Leu Trp Gly Leu Ala Gly  
 85 90 95

Leu Asn Ser Cys Pro Val Lys Glu Ala Asn Gln Ser Thr Leu Glu Asn  
 100 105 110

Phe Leu Glu Arg Leu Lys Thr Ile Met Arg Glu Lys Tyr Ser Lys Cys  
 115 120 125

Ser Ser  
 130

<210> 6  
 <211> 153  
 <212> PRT  
 <213> Artificial Sequence

<220>  
 <223> recombinant human IL-7 (rhIL-7)

<400> 6

Met Asp Cys Asp Ile Glu Gly Lys Asp Gly Lys Gln Tyr Glu Ser Val  
 1 5 10 15

Leu Met Val Ser Ile Asp Gln Leu Leu Asp Ser Met Lys Glu Ile Gly  
 20 25 30

Ser Asn Cys Leu Asn Asn Glu Phe Asn Phe Phe Lys Arg His Ile Cys  
 35 40 45

Asp Ala Asn Lys Glu Gly Met Phe Leu Phe Arg Ala Ala Arg Lys Leu  
 50 55 60

Arg Gln Phe Leu Lys Met Asn Ser Thr Gly Asp Phe Asp Leu His Leu  
 65 70 75 80

Leu Lys Val Ser Glu Gly Thr Thr Ile Leu Leu Asn Cys Thr Gly Gln  
 85 90 95

Val Lys Gly Arg Lys Pro Ala Ala Leu Gly Glu Ala Gln Pro Thr Lys  
 100 105 110

Ser Leu Glu Glu Asn Lys Ser Leu Lys Glu Gln Lys Lys Leu Asn Asp  
 115 120 125

Leu Cys Phe Leu Lys Arg Leu Leu Gln Glu Ile Lys Thr Cys Trp Asn  
 130 135 140

Lys Ile Leu Met Gly Thr Lys Glu His  
 145 150

<210> 7

<211> 115

<212> PRT

<213> Artificial Sequence

<220>

<223> recombinant human IL-15 (rhIL-15)

<400> 7

Met Asn Trp Val Asn Val Ile Ser Asp Leu Lys Lys Ile Glu Asp Leu  
 1 5 10 15

Ile Gln Ser Met His Ile Asp Ala Thr Leu Tyr Thr Glu Ser Asp Val  
 20 25 30

His Pro Ser Cys Lys Val Thr Ala Met Lys Cys Phe Leu Leu Glu Leu  
 35 40 45

Gln Val Ile Ser Leu Glu Ser Gly Asp Ala Ser Ile His Asp Thr Val  
 50 55 60

Glu Asn Leu Ile Ile Leu Ala Asn Asn Ser Leu Ser Ser Asn Gly Asn  
 65 70 75 80

Val Thr Glu Ser Gly Cys Lys Glu Cys Glu Glu Leu Glu Glu Lys Asn  
 85 90 95

Ile Lys Glu Phe Leu Gln Ser Phe Val His Ile Val Gln Met Phe Ile  
 100 105 110

Asn Thr Ser  
 115

<210> 8  
 <211> 132  
 <212> PRT  
 <213> Artificial Sequence

<220>  
 <223> recombinant human IL-21 (rhIL-21)

<400> 8

Met Gln Asp Arg His Met Ile Arg Met Arg Gln Leu Ile Asp Ile Val  
 1 5 10 15

Asp Gln Leu Lys Asn Tyr Val Asn Asp Leu Val Pro Glu Phe Leu Pro  
 20 25 30

Ala Pro Glu Asp Val Glu Thr Asn Cys Glu Trp Ser Ala Phe Ser Cys  
 35 40 45

Phe Gln Lys Ala Gln Leu Lys Ser Ala Asn Thr Gly Asn Asn Glu Arg  
 50 55 60

Ile Ile Asn Val Ser Ile Lys Lys Leu Lys Arg Lys Pro Pro Ser Thr  
 65 70 75 80

Asn Ala Gly Arg Arg Gln Lys His Arg Leu Thr Cys Pro Ser Cys Asp  
 85 90 95

Ser Tyr Glu Lys Lys Pro Pro Lys Glu Phe Leu Glu Arg Phe Lys Ser  
 100 105 110

Leu Leu Gln Lys Met Ile His Gln His Leu Ser Ser Arg Thr His Gly  
 115 120 125

Ser Glu Asp Ser  
 130

**PROCESSES FOR PRODUCTION OF TUMOR INFILTRATING  
LYMPHOCYTES AND USES OF SAME IN IMMUNOTHERAPY**

5

**ABSTRACT OF THE DISCLOSURE**

The present invention provides improved and/or shortened methods for expanding TILs and producing therapeutic populations of TILs, including novel methods for expanding TIL populations in a closed system that lead to improved efficacy, improved phenotype, and  
10 increased metabolic health of the TILs in a shorter time period, while allowing for reduced microbial contamination as well as decreased costs. Such TILs find use in therapeutic treatment regimens.

15