



(86) Date de dépôt PCT/PCT Filing Date: 2006/03/14  
 (87) Date publication PCT/PCT Publication Date: 2006/09/21  
 (45) Date de délivrance/Issue Date: 2014/04/29  
 (85) Entrée phase nationale/National Entry: 2007/09/11  
 (86) N° demande PCT/PCT Application No.: US 2006/009102  
 (87) N° publication PCT/PCT Publication No.: 2006/099408  
 (30) Priorité/Priority: 2005/03/14 (US60/661,853)

(51) Cl.Int./Int.Cl. *B61K 9/02* (2006.01)  
 (72) Inventeurs/Inventors:  
 URMSON, W. THOMAS, JR., US;  
 DOWNEY, JOHN M., US;  
 BOARIO, PATRICK J., US;  
 MOSPAN, JOHN W., US  
 (73) Propriétaire/Owner:  
 KOPPERS DELAWARE, INC., US  
 (74) Agent: INTEGRAL IP

(54) Titre : PROCÉDE ET AGENCEMENT PERMETTANT D'ISOLER DES EXTREMITES DE RAILS  
 (54) Title: METHOD AND ARRANGEMENT TO INSULATE RAIL ENDS

(57) **Abrégé/Abstract:**

A rail joint arrangement comprises two rails. The rails have adjacent rail ends separated and thereby forming a gap. The rails have a top end containing a rail head and a bottom end. The gap is defined between the top end and the bottom end of the rails, and the width of the gap is non-uniform throughout its entire length. In addition, the rail joint arrangement comprises at least one electric insulator positioned within the gap. The rail joint arrangement is fastened together by a rail joint bar attaching the two rails together.



(12) INTERNATIONAL APPLICATION PUBLISHED UNDER THE PATENT COOPERATION TREATY (PCT)

(19) World Intellectual Property Organization  
International Bureau(43) International Publication Date  
21 September 2006 (21.09.2006)

PCT

(10) International Publication Number  
**WO 2006/099408 A2**(51) International Patent Classification:  
*B61K 9/02* (2006.01)(21) International Application Number:  
PCT/US2006/009102

(22) International Filing Date: 14 March 2006 (14.03.2006)

(25) Filing Language: English

(26) Publication Language: English

(30) Priority Data:  
60/661,853 14 March 2005 (14.03.2005) US(71) Applicant (for all designated States except US): **PORTEC RAIL PRODUCTS, INC.** [US/US]; P.o. Box 38250, 900 Freeport Road, Pittsburgh, Pennsylvania 15238-8250 (US).

(72) Inventors; and

(75) Inventors/Applicants (for US only): **URMSON, JR., W., Thomas** [US/US]; 1375 Pittsburgh Road, Valencia, Pennsylvania 16059 (US). **DOWNEY, John, M.** [US/US]; 4734 Nottingham Court, Ashland, Kentucky 41101 (US). **BOARIO, Patrick, J.** [US/US]; 81 Sunrise Drive, Allegheny Township, Pennsylvania 15656 (US). **MOSPAN, John, W.** [US/US]; 925 Stevendale Drive, Pittsburgh, Pennsylvania 15221 (US).(74) Agents: **REZNICK, Paul, M.** et al.; The Webb Law Firm, 700 Koppers Building, 436 Seventh Avenue, Pittsburgh, Pennsylvania 15219 (US).

(81) Designated States (unless otherwise indicated, for every kind of national protection available): AE, AG, AL, AM, AT, AU, AZ, BA, BB, BG, BR, BW, BY, BZ, CA, CH, CN, CO, CR, CU, CZ, DE, DK, DM, DZ, EC, EE, EG, ES, FI, GB, GD, GE, GH, GM, HR, HU, ID, IL, IN, IS, JP, KE, KG, KM, KN, KP, KR, KZ, LC, LK, LR, LS, LT, LU, LV, LY, MA, MD, MG, MK, MN, MW, MX, MZ, NA, NG, NI, NO, NZ, OM, PG, PH, PL, PT, RO, RU, SC, SD, SE, SG, SK, SL, SM, SY, TJ, TM, TN, TR, TT, TZ, UA, UG, US, UZ, VC, VN, YU, ZA, ZM, ZW.

(84) Designated States (unless otherwise indicated, for every kind of regional protection available): ARIPO (BW, GH, GM, KE, LS, MW, MZ, NA, SD, SL, SZ, TZ, UG, ZM, ZW), Eurasian (AM, AZ, BY, KG, KZ, MD, RU, TJ, TM), European (AT, BE, BG, CH, CY, CZ, DE, DK, EE, ES, FI, FR, GB, GR, HU, IE, IS, IT, LT, LU, LV, MC, NL, PL, PT, RO, SE, SI, SK, TR), OAPI (BF, BJ, CF, CG, CI, CM, GA, GN, GQ, GW, ML, MR, NE, SN, TD, TG).

**Published:**

— without international search report and to be republished upon receipt of that report

For two-letter codes and other abbreviations, refer to the "Guidance Notes on Codes and Abbreviations" appearing at the beginning of each regular issue of the PCT Gazette.

(54) Title: METHOD AND ARRANGEMENT TO INSULATE RAIL ENDS

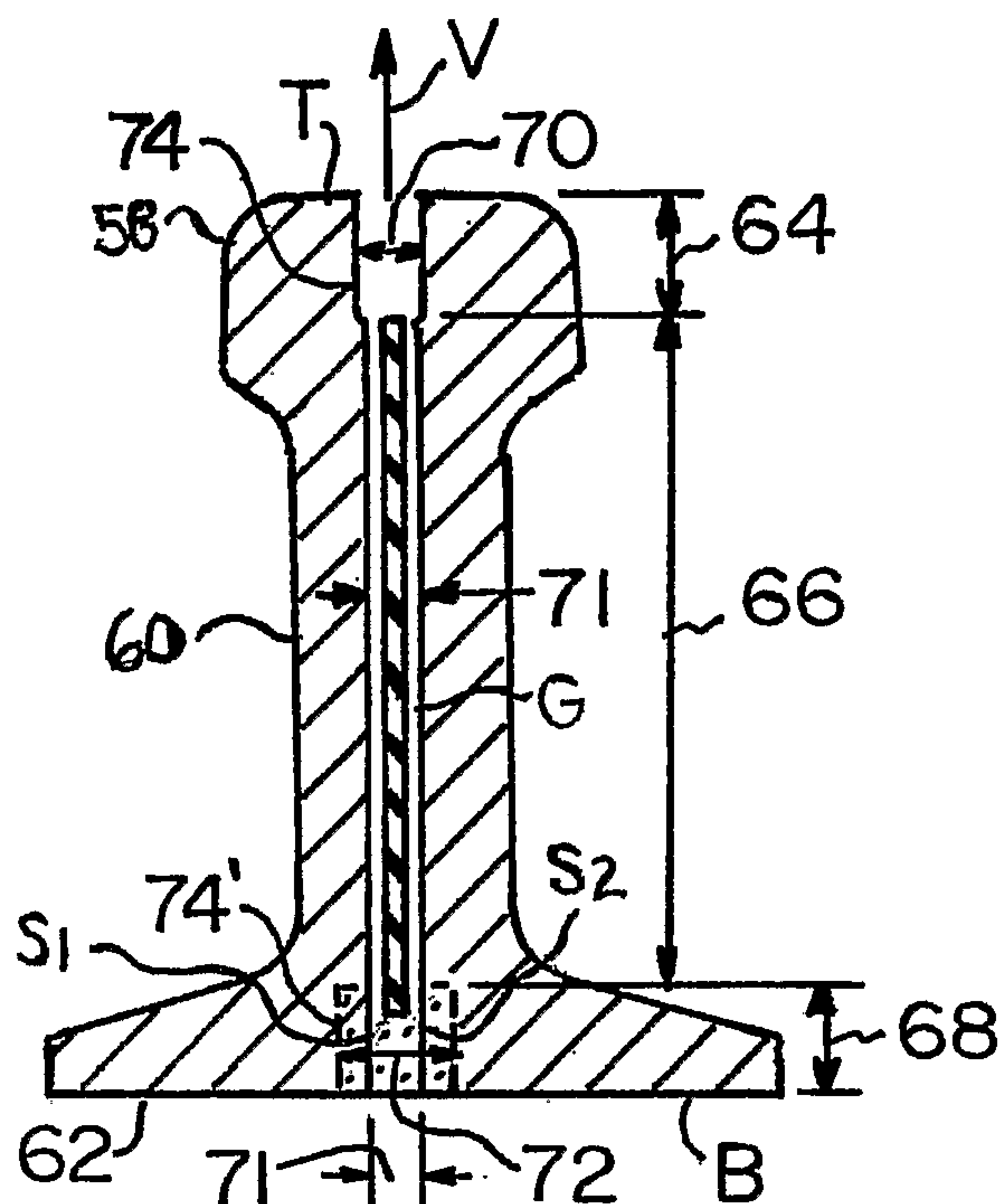

(57) Abstract: A rail joint arrangement comprises two rails. The rails have adjacent rail ends separated and thereby forming a gap. The rails have a top end containing a rail head and a bottom end. The gap is defined between the top end and the bottom end of the rails, and the width of the gap is non-uniform throughout its entire length. In addition, the rail joint arrangement comprises at least one electric insulator positioned within the gap. The rail joint arrangement is fastened together by a rail joint bar attaching the two rails together.

WO 2006/099408 A2

## METHOD AND ARRANGEMENT TO INSULATE RAIL ENDS

### CROSS REFERENCE TO RELATED APPLICATIONS

**[0001]** This application is related to U.S. Provisional Application No. 60/661,853, filed March 14, 2005.

### BACKGROUND OF THE INVENTION

#### Field of the Invention

**[0002]** The present invention relates to a rail joint arrangement and a method of forming a rail joint.

#### Description of Related Art

**[0003]** A rail system, which permits more than one train to travel on one stretch of track of rail, is generally divided into sections or blocks. The purpose of dividing railroad rails of a rail system into sections is to detect the presence of a train on a section of rail at any given time. Each rail section is electrically isolated from all other sections so that a high electrical resistance can be measured over the rail section when no train is present in that section. When a train enters a rail section, the train will short circuit adjacent railroad rails in which the electrical resistance in the rail section drops, thereby indicating the presence of a train.

**[0004]** Railroad rails are generally welded to each other or attached to each other by a rail joint. Referring to Fig. 1A, a typical rail joint 2 having a rail end 4 of a first rail R1 and another rail end 6 of a second rail R2 is shown. Rail joint 2 is shown having an electrical insulator 8 and is connected by rail joint bar 12 and rail joint bar 10. Rail joint 2 also shows a gap between E-E where the electrical insulator 8 is placed. With reference to Fig. 1B, a cross section of rail joint 2 is shown illustrating a uniform gap width between the rail end 4 and rail end 6.

**[0005]** There are other different uniform gap shapes. In Fig. 2A, an illustration is shown of another rail joint 16 having angled rail ends at 45°. Rail joint 16 has a rail end 18 of a first rail R1' and a rail end 20 of a second rail R2', with an electrical insulator 22 within the gap that is formed between rail end 18 and rail end 20. A cross-sectional view of rail joint 16 shows the rail joint having rail end 18 and rail end 20, with a gap between E'-E' and an electrical insulator 22 within the gap. As shown in Fig. 2A, the width of the gap is still uniform throughout the angled gap. Some prior art arrangements utilize 45° chamfers or small radii along upper and lower rail end edges to prevent sharp edges. Typically, these chamfers and radiused surfaces have a depth and width in the ranges of 0.030"-0.090".

[0006] Presently, ends of rails are connected together by rail joints. Typically, as shown in Figs. 1A, 1B, 2A, and 2B, rail ends abut each other with flat surfaces that form a uniform gap between the rail ends. Over time, the tensile and flexural forces are higher at a center portion of the rail joints where the two railroad rails are joined. Eventually, the forces acting upon the rails deteriorate the insulator between the rails and they become non-insulated and rub up against each other and form short circuits in the rails. Therefore, it is an object of the present invention to overcome this problem.

#### SUMMARY OF THE INVENTION

[0007] The present invention provides for a rail joint arrangement comprising two rails. The rails have adjacent rail ends separated and thereby forming a gap. The gap has a non-uniform width and can be radiused at the top and bottom. The rails have a top end containing a rail head and a bottom end. The gap is defined between the top end and the bottom end of the rails, and the width of the gap is non-uniform throughout its entire length. In addition, the rail joint arrangement comprises at least one electric insulator positioned within the gap. The rail joint arrangement is fastened together by a rail joint bar attaching the two rails together.

[0008] The present invention also provides for a rail for use in a rail joint arrangement. The rail includes a rail body, which comprises a first end having a first rail end surface and a second end having a second rail end surface. The rail body contains a cross-sectional profile comprising a head attached to a web portion and the web portion connected to a base. The head is positioned on an opposite side of the web from the base. The rail contains a cross-sectional profile that extends along a vertical axis and the first rail end surface is not completely contained in any flat plane that contains an axis that is parallel to the vertical axis.

[0009] The present invention further provides for a method for forming a rail joint that includes providing two rails. Each rail includes a rail body, which comprises a first end having a first rail end surface and a second end having a second rail end surface. The rail body contains a cross-sectional profile comprising a head attached to a web portion and the web portion connected to a base. The head is positioned on an opposite side of the web from the base. The rail contains a cross-sectional profile that extends along a vertical axis and the first rail end surface is not completely contained in any flat plane that contains an axis that is parallel to the vertical axis. The method includes positioning respective rails having a top end and a bottom end adjacent each other to form a gap. The rail ends define a gap between the top end and the bottom end of the rails and the gap width is non-uniform throughout its

entire length. Finally, insulating material is placed within the gap and the rails are attached by fasteners, thereby forming a rail joint.

#### BRIEF DESCRIPTION OF THE DRAWINGS

- [0010] Fig. 1A is a top plan view showing a prior art rail end arrangement having ends that are transverse to the rails;
- [0011] Fig. 1B is a sectional view taken along lines IB-IB of Fig. 1A;
- [0012] Fig. 2A is a top plan view of a prior art rail end arrangement having ends that are at a 45° angle;
- [0013] Fig. 2B is a sectional view taken along lines IIB-IIB of Fig. 2A;
- [0014] Fig. 3 shows a top plan view of a rail end arrangement made in accordance with the present invention;
- [0015] Figs. 3A-3H are sections taken along lines IIIA-IIIH, IIIB-IIIB, IIIC-IIIC, IIID-IIID, IIIE-IIIE, IIIF-IIIF, IIIG-IIIG, IIIH-IIIH, respectively, of Fig. 3;
- [0016] Fig. 4 is an end sectional view of an embodiment of a rail made in accordance with the present invention;
- [0017] Fig. 5 is an end sectional view of another embodiment of a rail made in accordance with the present invention;
- [0018] Fig. 6 is an end view of yet another embodiment of an end rail made in accordance with the present invention;
- [0019] Figs. 7A-7B are top plan views of different low angle cuts of ends of rail;
- [0020] Figs. 8A-8B are top plan views of different low angle cuts of ends of rails; and
- [0021] Figs. 9A-9C are sectional views of lower portions of adjacent rail ends used in rail joints made in accordance with the present invention.

#### DESCRIPTION OF THE PREFERRED EMBODIMENTS

[0022] Referring to Fig. 3, a rail joint arrangement made in accordance with the present invention shows rail joint 30 having a rail 32 and a rail 34, with rail end surface 36 and rail end surface 38, respectively. The two rails 32, 34 are positioned having the rail end surfaces 36, 38 adjacent each other to form a gap 40 having a width in between them. Rail 32 is a typical rail having a top end 42 and a bottom end 44. The rail joint arrangement is fastened together once an insulator is placed within the gap by a rail joint bar 46 or 46', which extends along the length of the gap 40 in which the insulator is to be placed.

[0023] Cross sections IIIA-IIIH, IIIB-IIIB, IIIC-IIIC, IIID-IIID, IIIE-IIIE, IIIF-IIIF, IIIG-IIIG, and IIIH-IIIH, shown in Figs. 3A-3H, show the rail end surfaces 36 and 38 at various positions taken along the rail joint 30. As is shown, each of cross sections of Figs. 3A-3H shows rail 32 and rail 34 having a top end 42 and a bottom end 44. Also shown in Figs. 3A-3H, typical to rails, are the rails having a web portion 60 connected to a head 58 and a base 62, the web portion 60 being intermediate to the head 58 and the base 62. Rail 32 and rail 34 are positioned adjacent each other to form gap 40. As shown in Fig. 3, the complete rail end surfaces 36 or 38 are not contained in a flat plane, for example, plane P that includes line V' that is parallel to line V shown in Fig. 3A and is perpendicular to the drawing surface (extends into the paper) due to the formation of the gap 40 having more than one width. The width of gap 40 is larger at the top end 42 than an intermediate portion 43 or bottom end 44, as is shown in Figs. 3A-3H. Once the rail end surface 36 and rail end surface 38 are positioned adjacent one another to form gap 40, an electrical insulator 41 can be positioned within the gap 40. The electrical insulator 41 can be made of material such as fiberglass, or a polymeric material such as polyurethane. Once the electrical insulator 41 is placed within gap 40, an electrically-insulating epoxy (not shown in Figs. 3A-3H) is dispersed into the gap 40 to fill the remaining cavity. Rail joint bar 46 and rail joint bar 46' are attached to the rails 32, 34 by preferably at least one fastener (not shown). Fasteners may be placed through a series of holes in the rail joints and rails to fasten the joints together. Fasteners are placed through the rail joint bar and through the rail and fastened to the rail to form a tight fit. Typically, the fasteners coact with electrically-insulating bushings and washers.

[0024] With continuing reference to Fig. 3, rail joint 30 is formed by a Z-cut 48 of the rails 32 and 34. The Z-cut 48 includes an angled surface 82 cut along an angled surface axis A and transverse cuts T and T'. Alternatively, the rail joint can be formed by just an angled cut, without the transverse cuts T and T', similar to the 45° angled cut shown in Fig. 2A. The angle range R is defined between a longitudinal axis L and the angled surface axis A.

[0025] As shown in Figs. 3A-3H, a U-shaped profile 45 is formed in the top end 42 when the rail end surfaces 36 and 38 are placed together. The gap 40 is non-uniform. In other words, given a vertical axis V, the rail end surfaces 36 and 38 of the gap 40 in the top end 42 form the U-shaped gap 45 and the rail end surfaces 36 and 38 of the remaining gap 40 cannot be entirely contained in any vertical axis V.

[0026] In another preferred embodiment shown in Fig. 4, a top gap width 70 can have a different shaped profile. The cross section in Fig. 4 is taken in a rail joint arrangement having a rectangular-shaped profile 74. The cross section can have a top portion 64, a middle

portion 66, and a bottom portion 68. The top portion 64 is shown to have a top gap width 70 wider than intermediate gap width 71 of middle portion 66. In addition, bottom portion 68 is shown having a bottom gap width 72, shown in phantom. When bottom gap width 72 is not present, intermediate gap width 71 of middle portion 66 merely extends down to bottom end B and, therefore, top gap width 70 is wider than the gap width in the bottom portion 68.

[0027] Bottom portion 68 is shown having a bottom gap width 72 in phantom, which, when optionally present, is wider than the intermediate gap width 71 of the middle portion 66. The profile of gap G as shown in the top portion 64 and the bottom portion 68 is rectangular-shaped profile 74 and 74' (shown in phantom). The gap in the bottom if optionally present can be any shape, not limited to the shape of the rectangular-shaped profile 74. The gap G is non-uniform in width. In other words, given a vertical axis V and a horizontal axis H, edges S1 or S2 of gap G in the top portion 64 and remaining gap G cannot be entirely contained in any vertical axis V chosen along horizontal axis H. In addition, when present, the edges S1 or S2 of a gap containing optional rectangular-shaped profile 74' in the bottom portion 68 and gap G of the middle portion 66 cannot be contained in any vertical axis V. Additionally, in Figs. 3A-3H, rail joint 30 comprises a head 58, a web portion 60, and a base 62.

[0028] Fig. 5 shows a cross section of a rail joint of another preferred embodiment of the present invention having a trapezoidal-shaped profile 78 and 78' (shown in phantom). Like reference numerals are used for like parts. In Fig. 5, the rail joint is shown having a top portion 64, a middle portion 66, and a bottom portion 68. As shown, the top portion 64 has a top gap width 70' wider than the intermediate gap width 71'. The bottom portion 68 shows, in phantom, a bottom gap width 72', which is also wider than the intermediate gap width 71'. Top gap width 70' and bottom gap width 72' are shown in Fig. 5 to have a trapezoidal-shaped profile 78 and 78'. Additionally, the top gap width 70' can be larger than the bottom gap width 72' or, alternatively, the bottom gap width 72' can be larger than the top gap width 70'. Lastly, top gap width 70' can be equal to bottom gap width 72'. When bottom gap width 72' is not present, intermediate gap width 71' of middle portion 66 merely extends down to bottom end B and, therefore, top gap width 70' is wider than the gap width in the bottom portion 68. It should be noted that profiles 72', 74', and 76' are optional and that, in lieu of these profiles, the intermediate gaps 71, 71', and 71'' can extend to the bottom of the rail as shown.

[0029] Fig. 6 illustrates a cross section of another embodiment having a U-shaped profile 76 and 76' (shown in phantom). In Fig. 6, the numerals are the same for like parts. The cross section is shown having a top T and a bottom B. The cross section is divided into a top

portion 64, a middle portion 66, and a bottom portion 68 to illustrate that the top gap width 70" is wider than the intermediate gap width 71", and bottom gap width 72", shown in phantom, can be wider than the intermediate gap width 71" of middle portion 66. When bottom gap width 72" is not present, intermediate gap width 71" of middle portion 66 merely extends down to bottom end B and, therefore, top gap width 70" is wider than the gap width in the bottom portion 68.

[0030] The gap widths as shown in Figs. 4-6 of the rail joint are larger near the top T and the bottom B so that an epoxy can be applied to the cavity to strengthen the bond.

[0031] In addition to the three aforementioned shapes, there can be other types of variations of shapes. For example, one rail end surface could be uniform while the other is angled and, therefore, still forms a non-uniform gap in the top gap width 70 or the bottom gap width 72 or both. Intermediate gap widths 71, 71', or 71" of the middle portion 66 is typically about 1/16", which is the typical thickness of the electrical insulator 41. Preferably, the top gap widths 70, 70', and 70" and bottom gap widths 72, 72', and 72", and the widest portions of top gap widths 70' and 70" and bottom gap widths 72' and 72", should be 1/8" or greater than intermediate gap width 71, 71', or 71". More preferably, top gap widths 70, 70', or 70" and bottom gap widths 72, 72', or 72", and the widest portions of top gap widths 70' and 70" and bottom gap widths 72' and 72", should be within the range of 1/8"-3/16" greater than intermediate gap width 71, 71', or 71" and, even more preferably, 3/16" or greater than intermediate gap width 71, 71', or 71". The gap depth of top portion 64 is preferably 1/2" or greater and, more preferably, within the range of about 1/2" to 1" and, even more preferably, within the range of 1" or greater. The gap depth of bottom portion 68 preferably is greater than 1/4", more preferably within the range of 1/4" to 1/2" and, even more preferably, greater than 1/2".

[0032] Shown in Fig. 9A is a sectional view of the cross section in Fig. 4 having a rectangular-shaped profile 74' in a bottom portion 94 of the gap 40. The rectangular-shaped profile 74' is shown having an insulator 90 extending into the gap 40 of the bottom portion 94. As shown in Fig. 9A, the rectangular-shaped profile 74' is in the bottom portion 94 of the cross section of Fig. 4, however, a rectangular-shaped profile could alternatively be placed in the top end. An epoxy 92 can be dispersed to the cavity surrounding the extending insulator 90. The epoxy can fill the gap around the extending insulator and thereby provide protection from elements and from flexural forces. The epoxy is electrically insulating.

[0033] Similar to Fig. 9A, Fig. 9B shows an end sectional view of the embodiment shown in Fig. 5 having a trapezoidal-shaped profile 78'. Trapezoidal-shaped profile 78' is shown

with epoxy 92 surrounding the extending insulator 90. Again, in Fig. 9C, a keystone-shaped profile 80' is shown, with bottom portion 94 containing extending insulator 90 surrounded by dispersed epoxy 92.

[0034] Returning to Fig. 3, the rail joint 30 has an angled gap 40 extending along an angled axis. The angle R as shown can be any angle which is less than  $90^\circ$  between the longitudinal axis L and the angled surface axis A. More preferably, the angle R should be less than  $45^\circ$  and, even more preferably, within the range of  $0^\circ$  to  $15^\circ$ . Figs. 7A and 7B show two types of gaps that are formed when the rail end surface 36 and rail end surface 38 of rails 32 and 34 are cut having angled surfaces. In Figs. 7A and 7B, an angled surface 82 and 82' are shown having an angled surface axis 84. Fig. 7A shows a slightly different gap from Fig. 7B.

[0035] In Figs. 8A and 8B, a straight cut is shown having an S-shape or Z-shape. Figs. 8A and 8B show a rail 32 and a rail 34 adjacent each other to form a gap 40. Rail end surface 36 and rail end surface 38 are S-shaped or Z-shaped. Rail end surfaces 36 and 38 form an S-shaped or Z-shaped gap 88 between rail 32 and rail 34.

[0036] With further reference to Fig. 3, rail 32 is shown having a rail end surface 36 on first end 50 and a first rail end surface 52. In addition, rail 32 has a second end 54 and a second rail end surface 56. Rail 32 is shown in the cross section of Fig. 3A to have a head 58, a web portion 60 attached to a base 62, the web portion connected to a base and the head is positioned on the opposite end as shown. The rail end surface 36 extends from first rail end surface 52 along gap 40. Rail end surface 36 extends across the complete width of the rail. In other words, rail surface 36 extends across the complete width of the head 58, the web portion 60, and the base 62. As previously stated, at no time does a flat plane P contain the complete first rail end surface 36. For that matter, straight vertical line V' does not contact the complete rail cross-sectional profiles, such as shown in Fig. 3A.

[0037] The present invention provides for a method of securing two rails 32 and 34, having rail end surface 36 and rail end surface 38. As shown in Fig. 3A, the rail end surface is not contained in a flat plane P parallel to any cross section along an axis for either rail 32 or rail 34.

[0038] Next, the respective rails are placed adjacent each other, with a top end 42 and a bottom end 44 of each rail adjacent to the top end 42 and bottom end 44 of the other. The gap 40 formed therein is defined by the rail end surfaces 36 and 38, which are placed adjacent each other. The gap 40 forms a profile at the top and, optionally, at the bottom. Examples of the profile can be rectangular, trapezoidal, or keystone in shape.

[0039] As discussed earlier, the gap 40 can also be wider in the top than the bottom and, alternatively, the gap can be wider in the bottom than the top. After the rails are positioned adjacent each other, an insulating material is placed within the gap. The insulating material can be as shown in Figs. 9A, 9B, and 9C as an epoxy placed in the top gap or bottom gap to fill the hole that has an extended fiberglass insulator. Next, the rails are attached together, thereby forming a rail joint. In Fig. 3, a rail joint bar 46 is used to fasten the rail joint together. However, any fastener known in the art can be used.

[0040] It will be readily appreciated by those skilled in the art that modifications may be made to the invention without departing from the concepts disclosed in the foregoing description. Accordingly, the particular embodiments described in detail herein are illustrative only.

WEBB004-1CA

9

1. A rail joint arrangement, comprising:

two rails having adjacent rail ends separated a distance apart to define a gap, each of said rails having a head portion, a web portion, and a base portion, said gap having a top portion, a middle portion, and a bottom portion that correspond to the head portion, the web portion, and the base portion of the rail, respectively, the head portion being vertically above the base portion;

at least one electric insulator positioned between the adjacent rail ends and filling the middle portion of the gap, the at least one electric insulator at the middle portion defining a constant width; and

a rail joint bar attaching the two rails together,

wherein at least one of said top and bottom portions of said gap has a width larger than the constant width throughout an entire length of at least one of said top and bottom portions, and wherein said width is less than a lateral transverse dimension of the respective one of said head and base portions.

2. The rail joint arrangement of claim 1, wherein said gap width is larger at the top end than the bottom end.

3. The rail joint arrangement of claim 1, wherein said gap width of the top portion is wider than the constant width.

4. The rail joint arrangement of claim 3, wherein said gap width of the bottom portion is wider than the constant width.

5. The rail joint arrangement of claim 4, wherein said gap width of the top portion and said gap width of the bottom portion are the same.

6. The rail joint arrangement of claim 3, wherein at least one of the top gap width has a cross-sectional profile and the bottom gap width has a cross-sectional profile, and wherein the cross-sectional profile comprises one of a substantially rectangular shape, U shape, frusto-triangular shape, trapezoidal shape, or keystone shape.

WEBB004-1CA

10

7. The rail joint arrangement of claim 1, wherein the rails are made of a conductive material.
8. The rail joint arrangement of claim 1, wherein the rail ends comprise angled surfaces.
9. The rail joint arrangement of claim 8, wherein the rails extend along a longitudinal axis, the angled surface extends along an angled surface axis, and an angle range of less than 90° is defined between the longitudinal axis and the angled surface axis.
10. The rail joint arrangement of claim 1, wherein the gap defines an S-shaped or Z-shaped profile.
11. The rail joint arrangement of claim 1, wherein the electric insulator comprises a polymeric material.
12. The rail joint arrangement of claim 1, wherein the gap has a cross-sectional profile and the electric insulator has a cross-sectional profile that is the same as the gap cross-sectional profile.
13. The rail joint arrangement of claim 1, wherein the electric insulator is made of one of polyurethane, fiberglass, or silicon adhesive.
14. The rail joint arrangement of claim 1, wherein the electric insulator extends from the middle portion of the gap into the bottom portion of the gap or the top portion of the gap, and wherein epoxy is dispersed to fill the remaining gap.
15. The rail joint of claim 1, wherein the rail joint comprises an electrically-insulating material.
16. The rail joint arrangement of claim 1, wherein the rail joints are attached to the rails by at least one fastener.

WEBB004-1CA

11

17. A method of forming a rail joint, comprising the steps of:

a) providing two rails, wherein each rail comprises a rail body having a first end having a first rail end surface and a second end having a second rail end surface, the rail body having a cross-sectional profile comprising a head attached to a web portion, the web portion connected to a base and the head is positioned on an opposite side of the web from the base, the head portion being vertically above the base portion;

b) positioning respective rails adjacent each other, wherein adjacent rail ends of the respective rails are separated a distance apart and define a gap therebetween, and wherein said gap has a top portion, a middle portion, and a bottom portion that correspond to the head portion, web portion, and base portion of the rail, respectively;

c) placing insulating material between the adjacent rail ends and filling the middle portion of the gap, the insulating material at the middle portion defining a constant width; and

d) attaching the rails together, thereby forming a rail joint,

wherein at least one of said top and bottom portions has a width larger than the constant width throughout an entire length of at least one of said top and bottom portions, and wherein said width is less than a lateral transverse dimension of the respective one of said head and base portions.

1/5

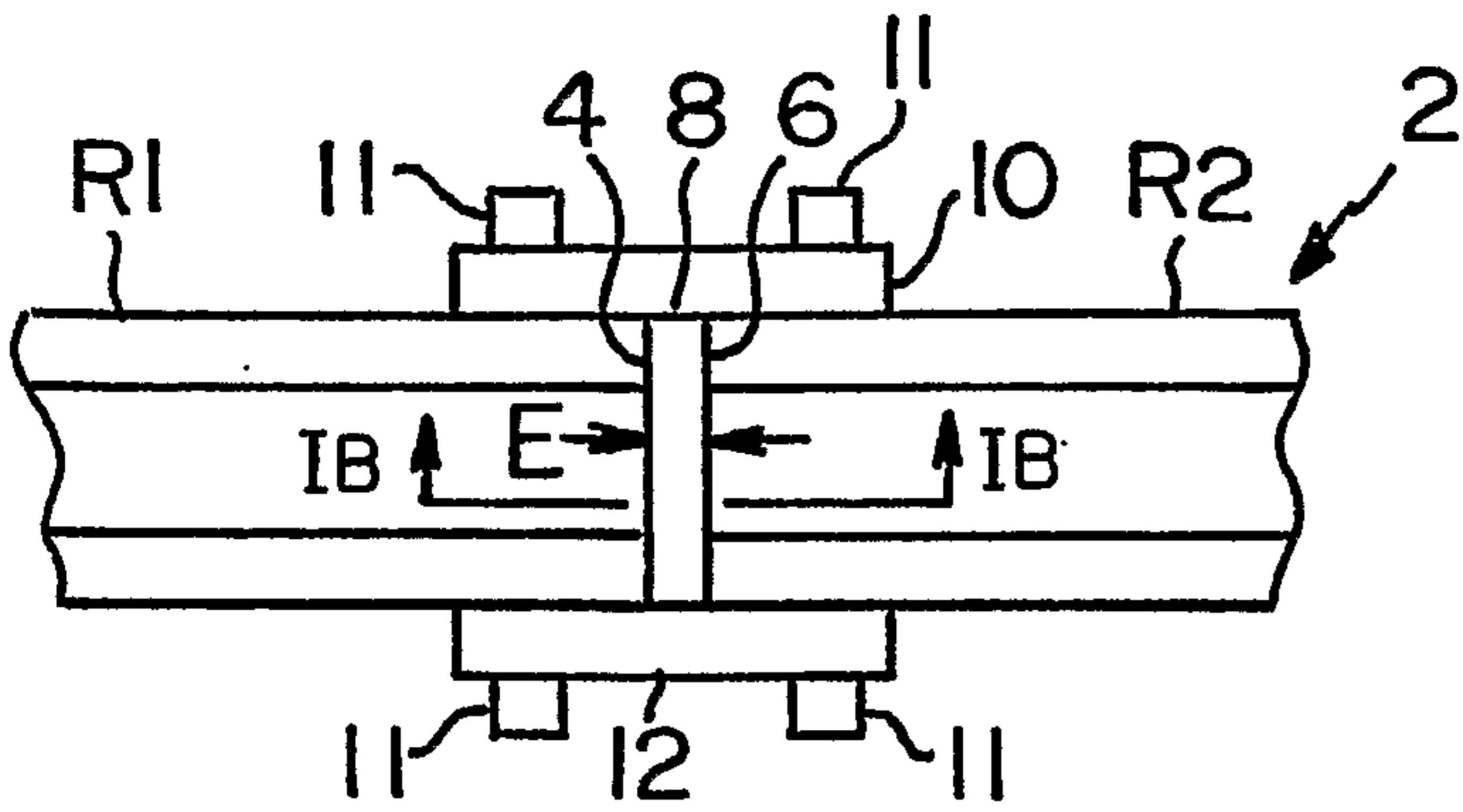

**FIG. 1A**  
PRIOR ART

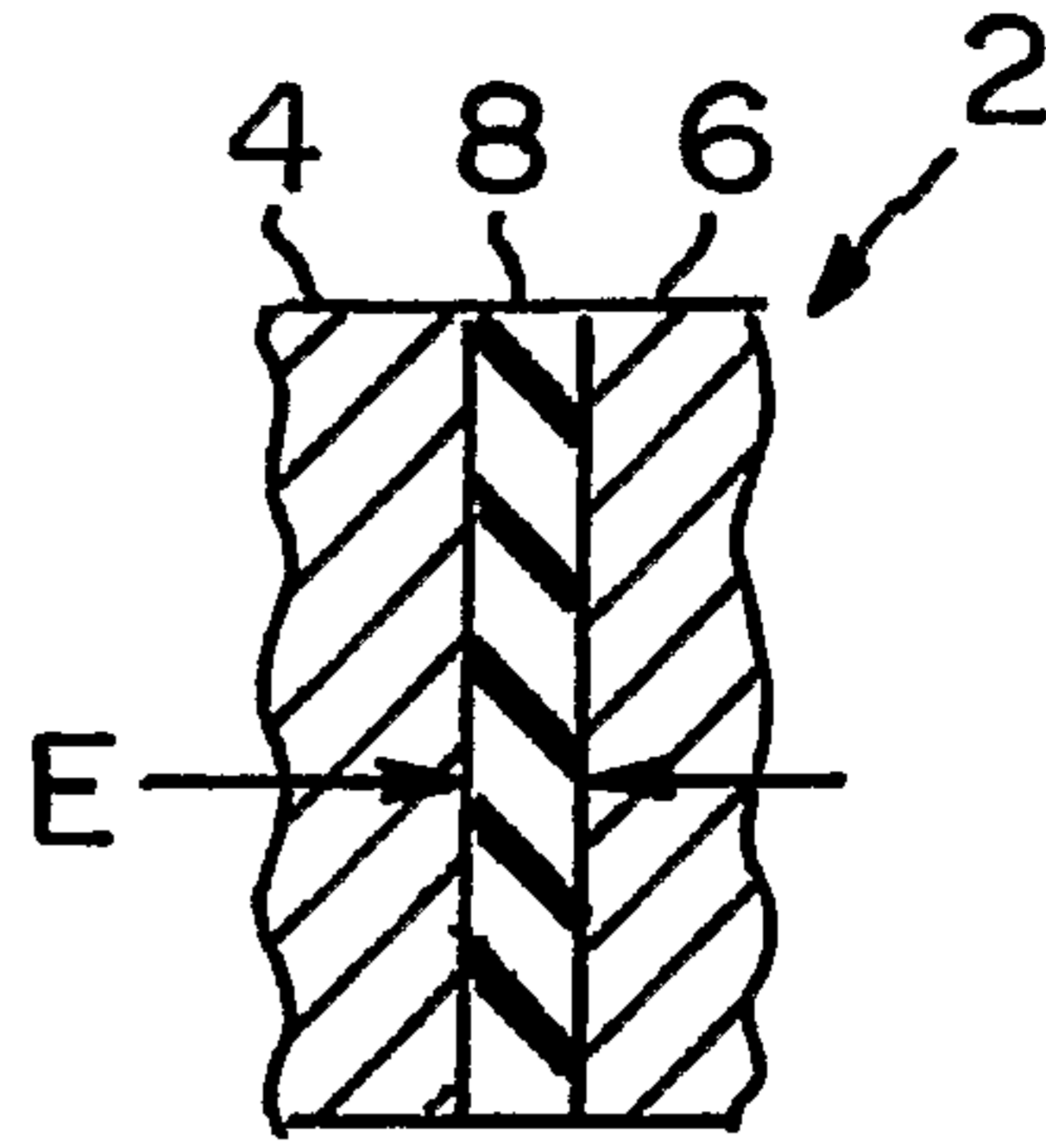

**FIG. 1B**  
PRIOR ART

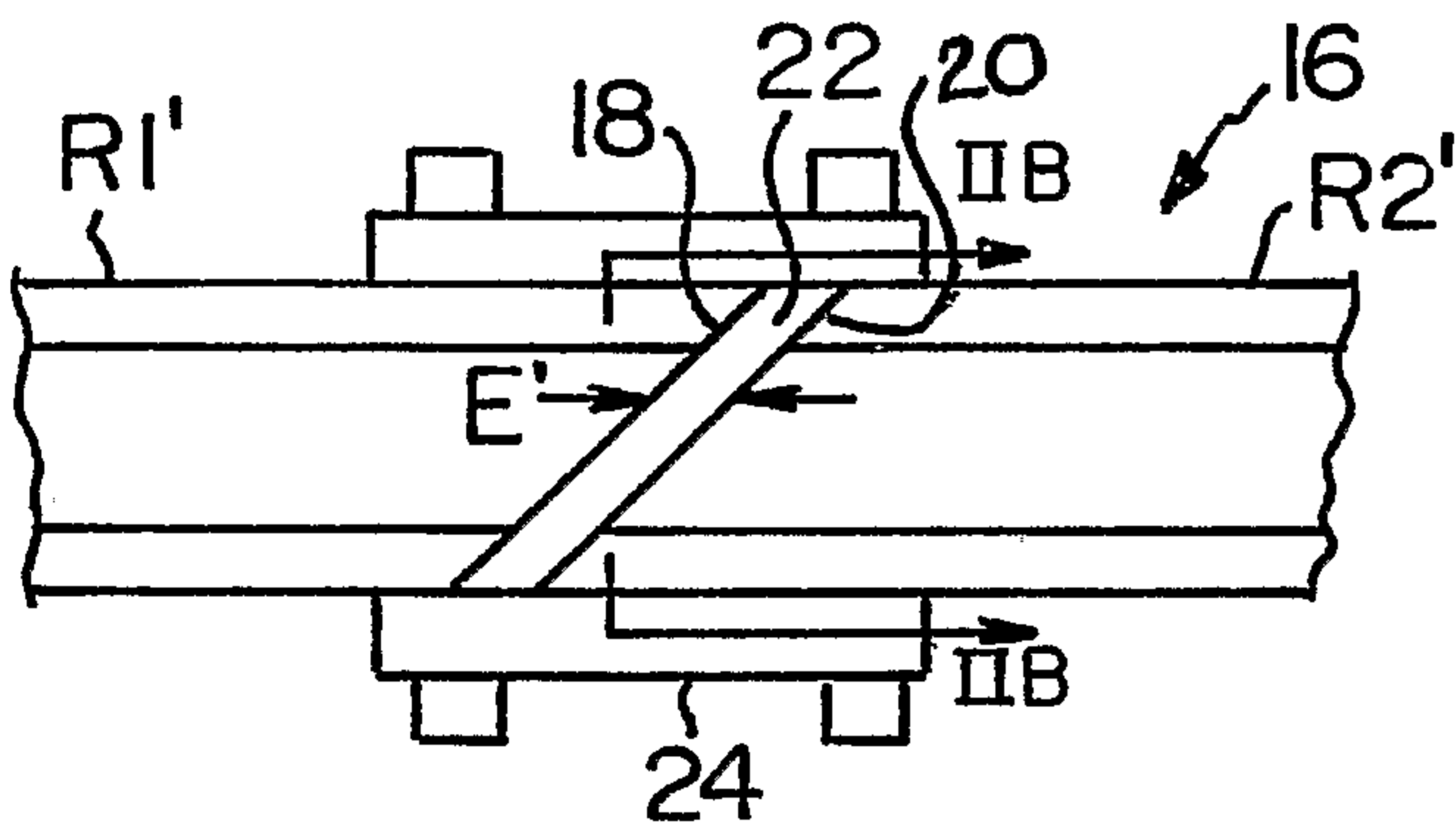

**FIG. 2A**  
PRIOR ART

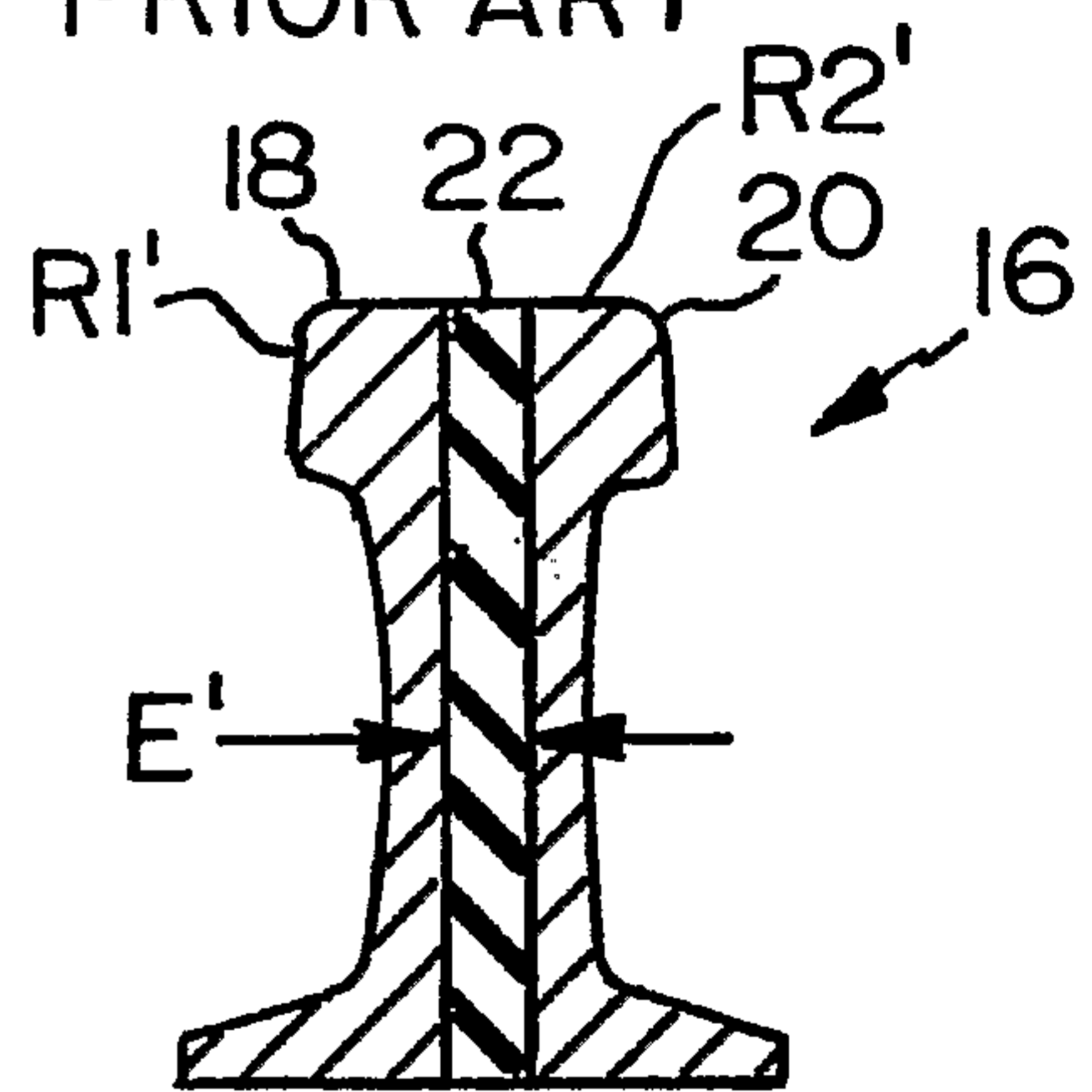

**FIG. 2B**  
PRIOR ART

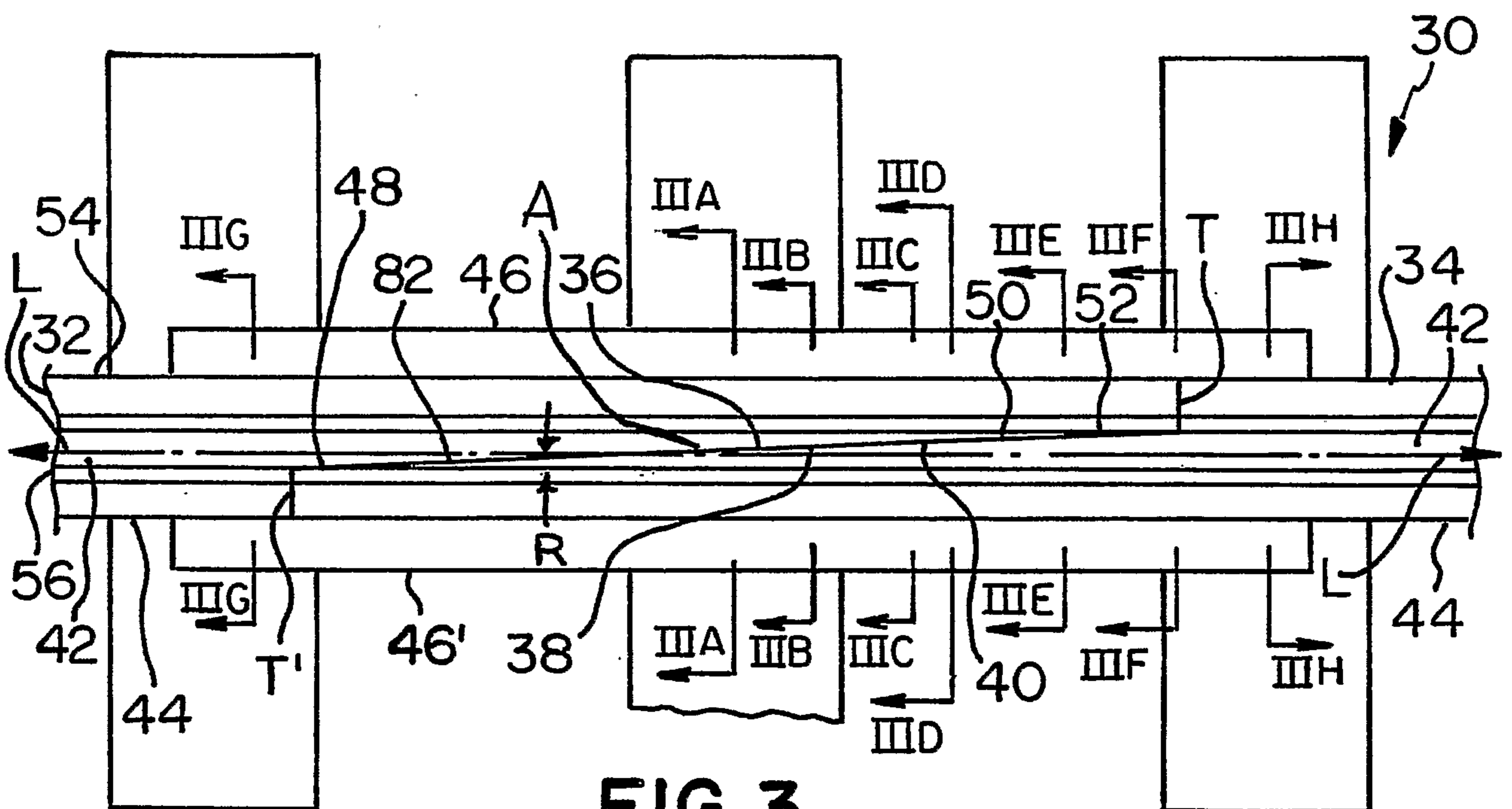

**FIG. 3**

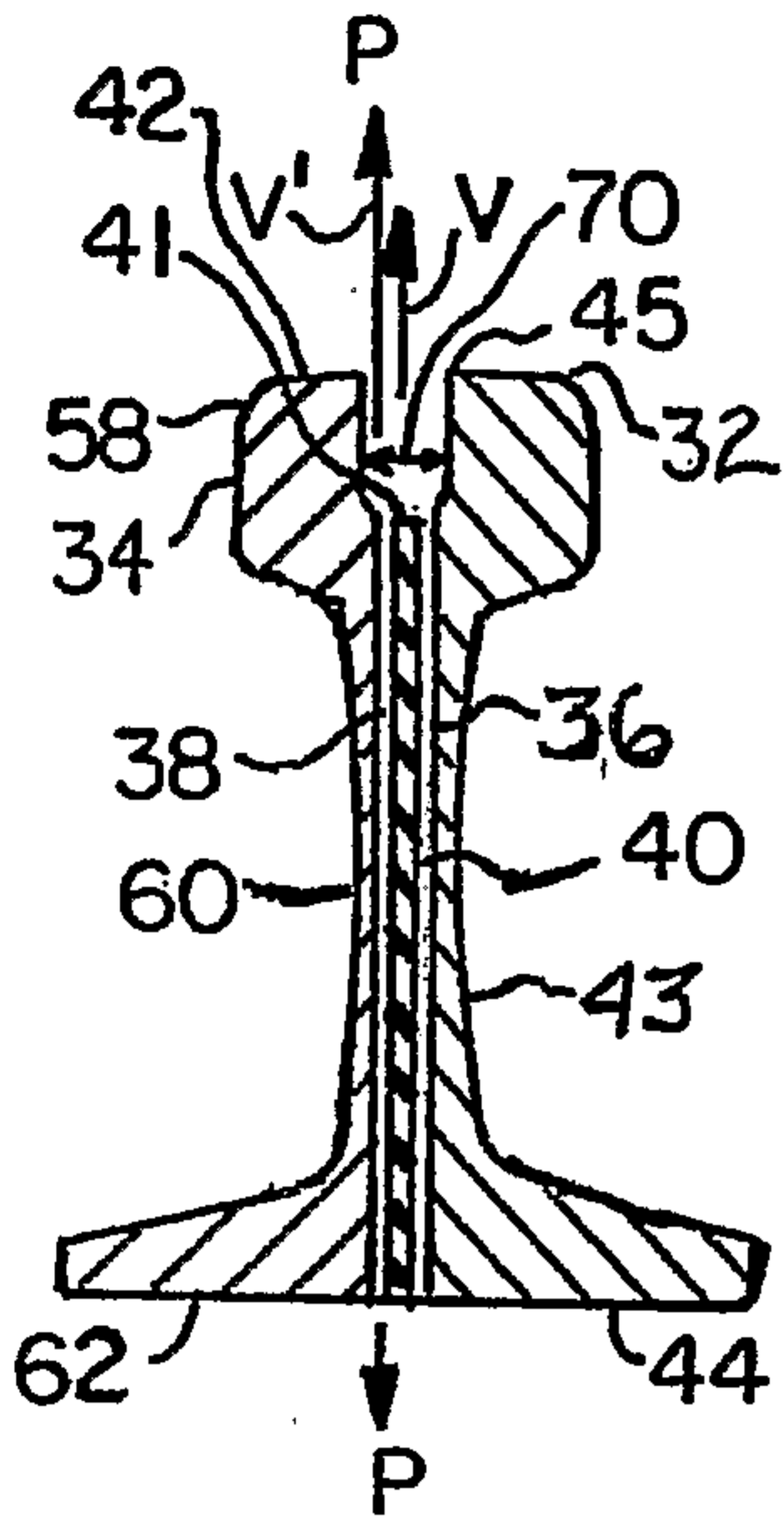

FIG. 3A

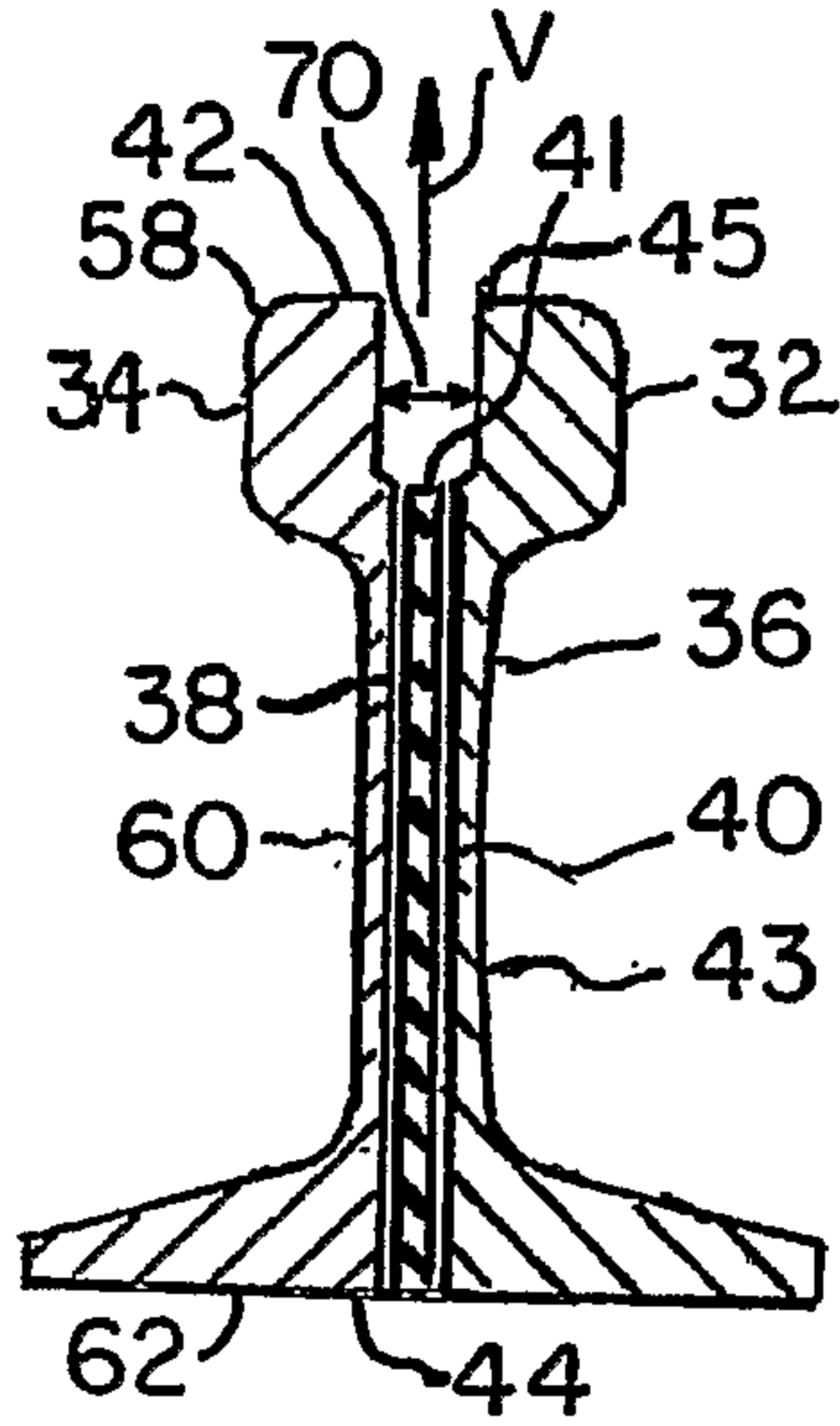

FIG. 3B

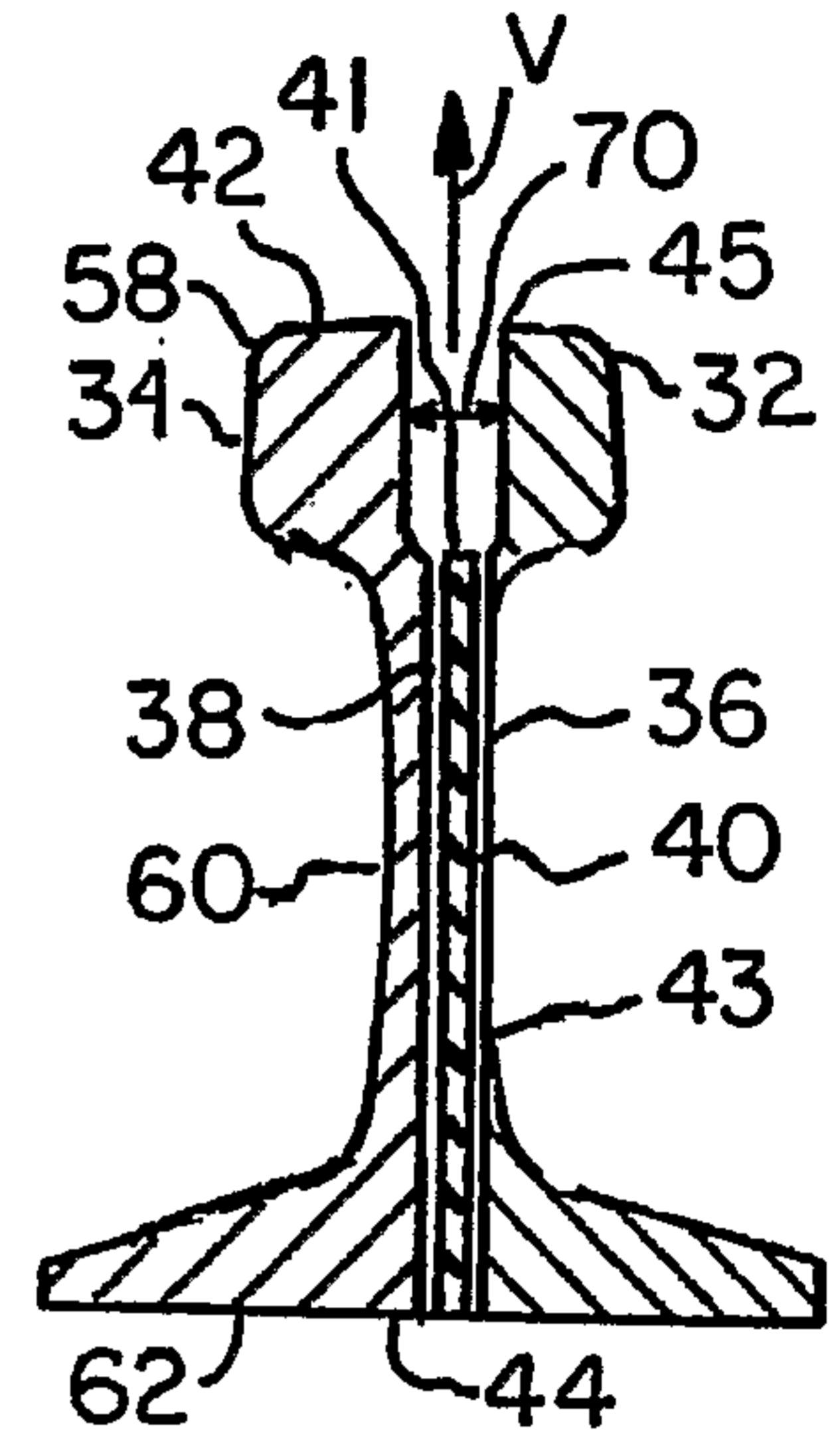

FIG. 3C

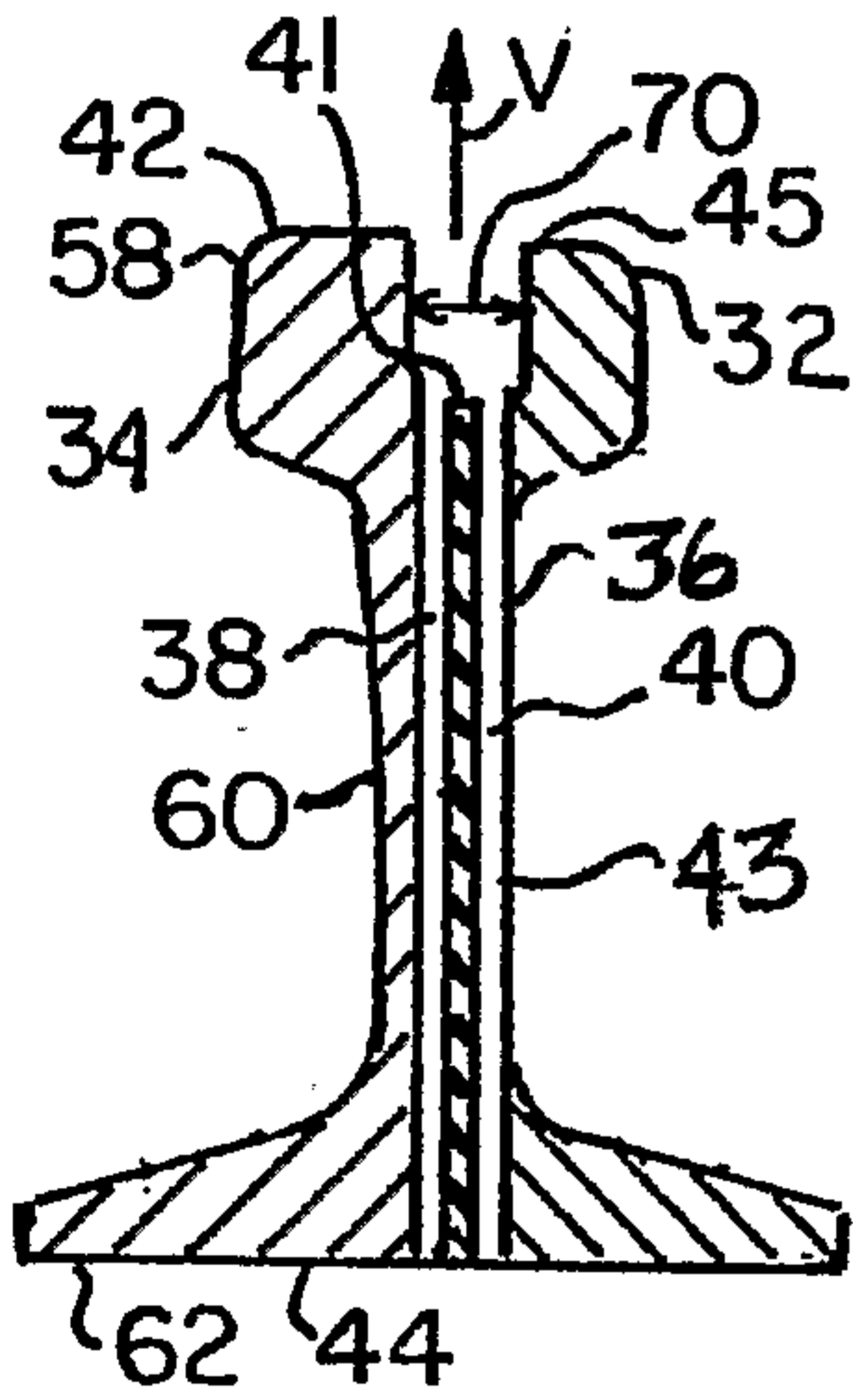

FIG. 3D

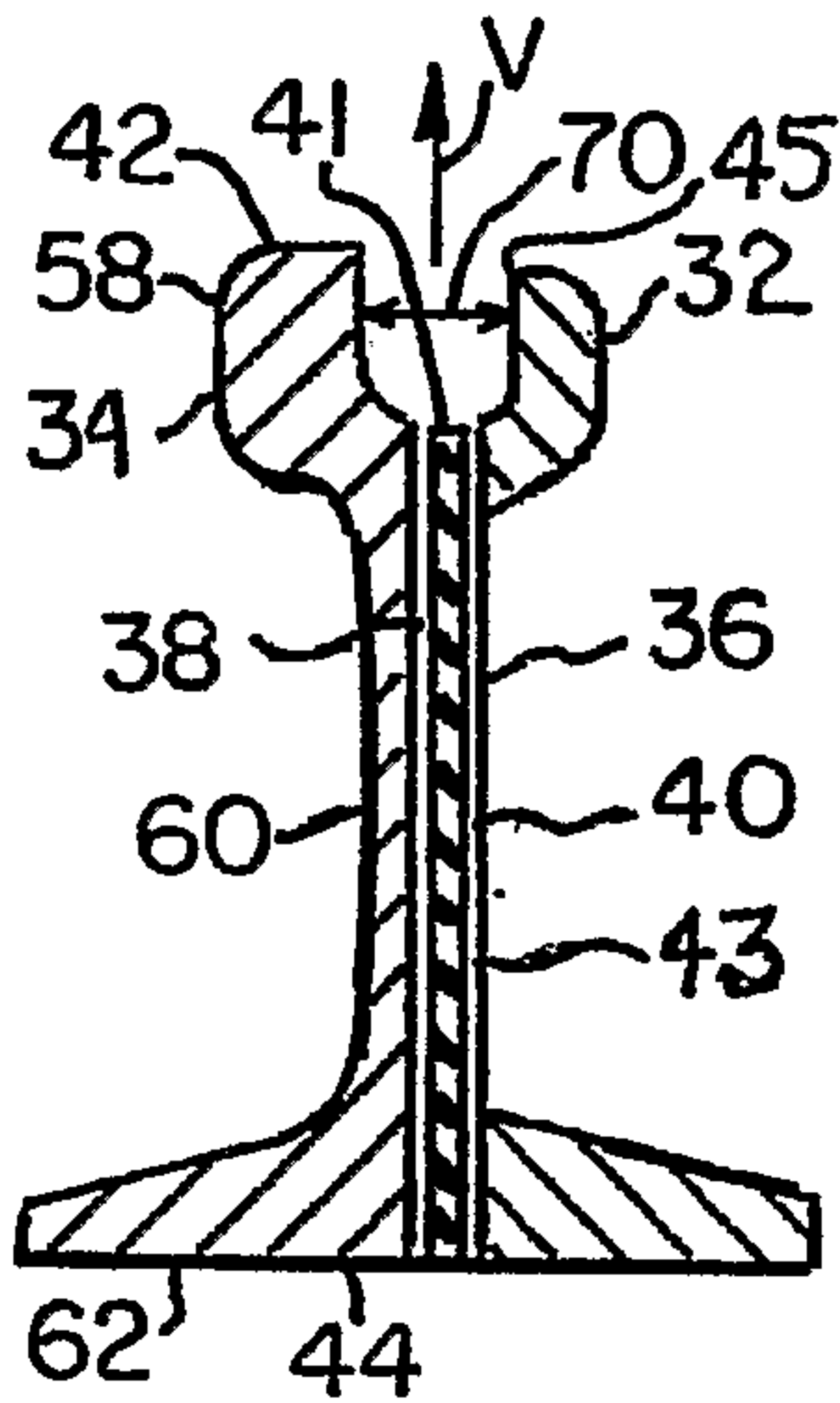

FIG. 3E

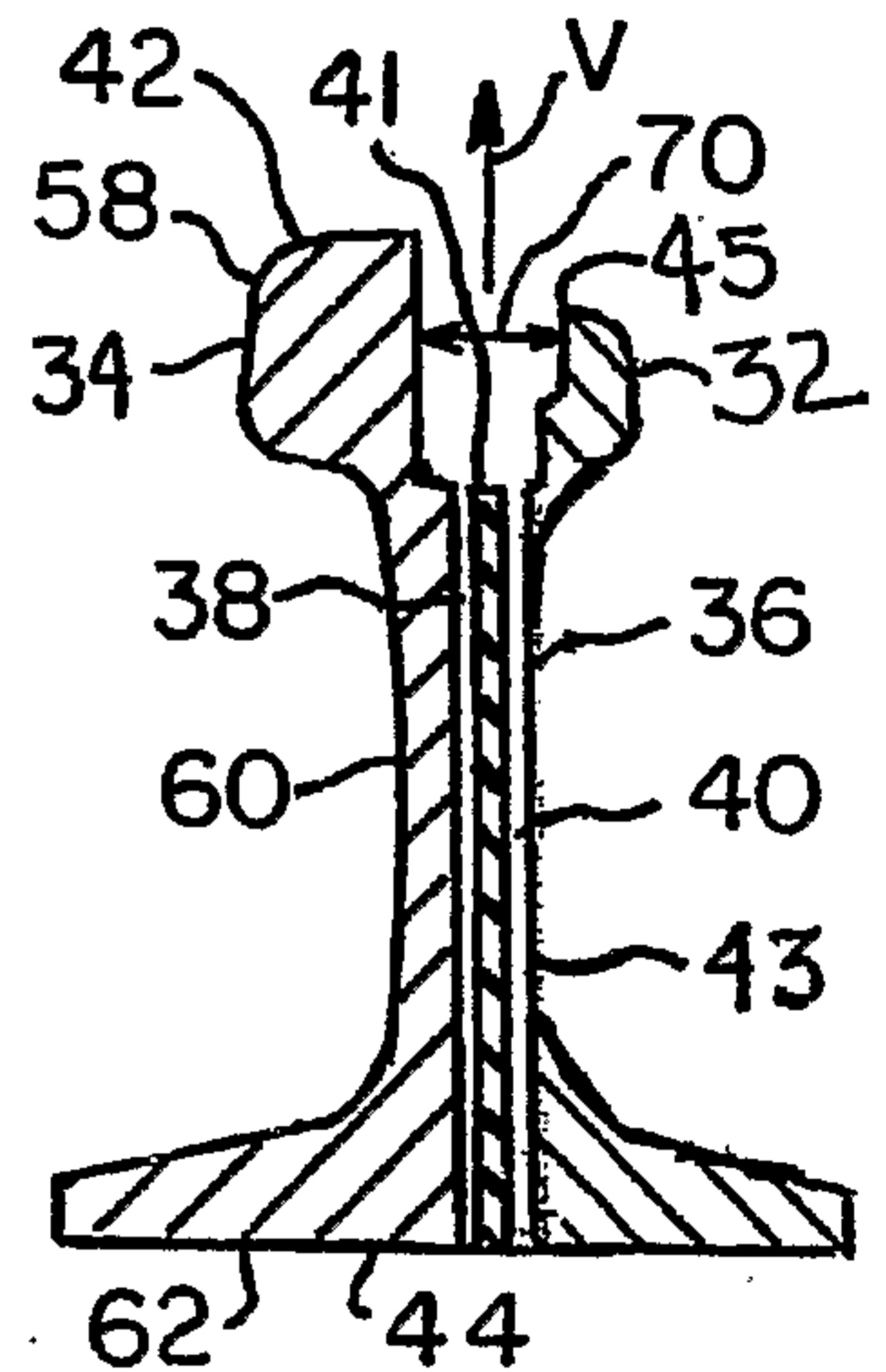

FIG. 3F

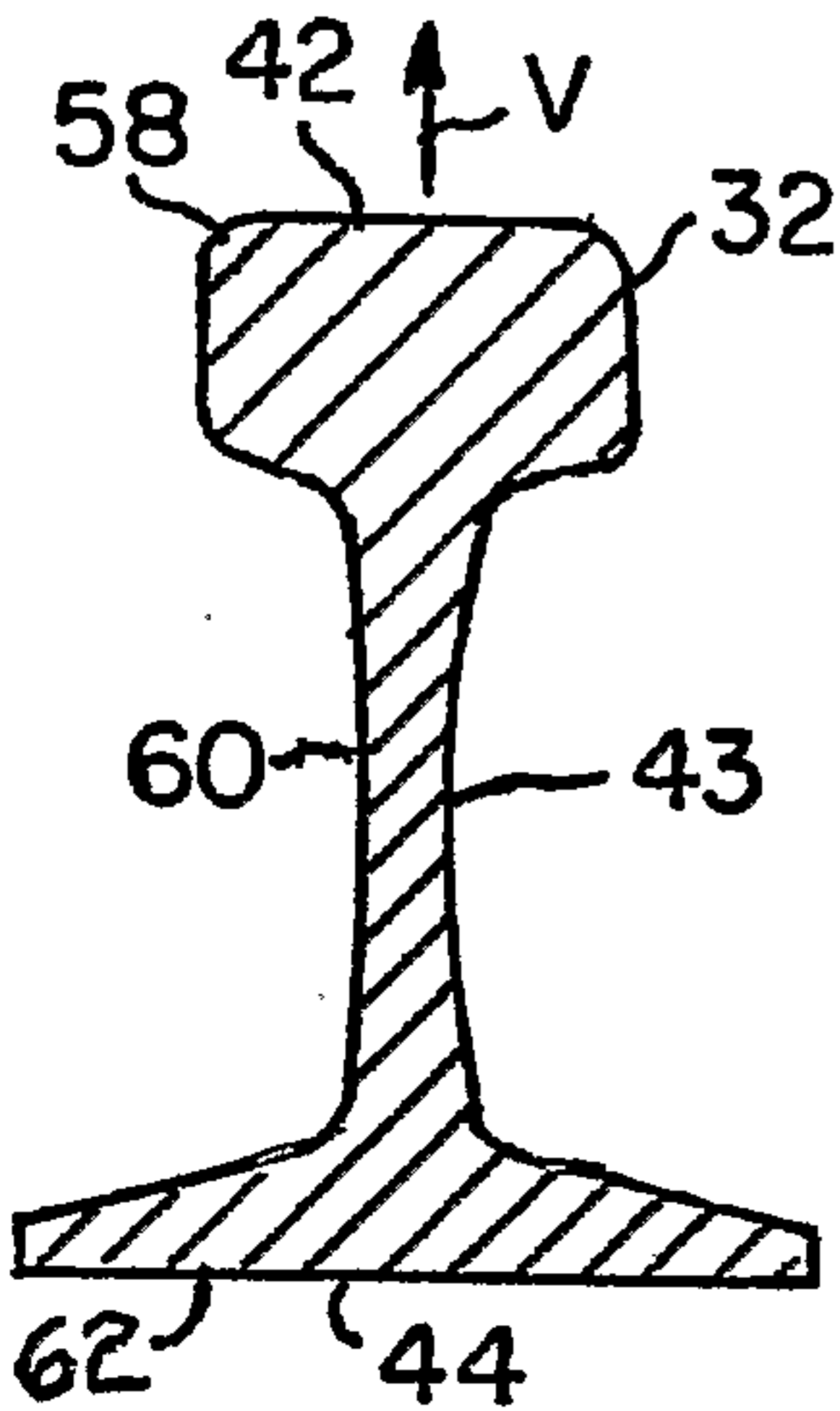

FIG. 3G

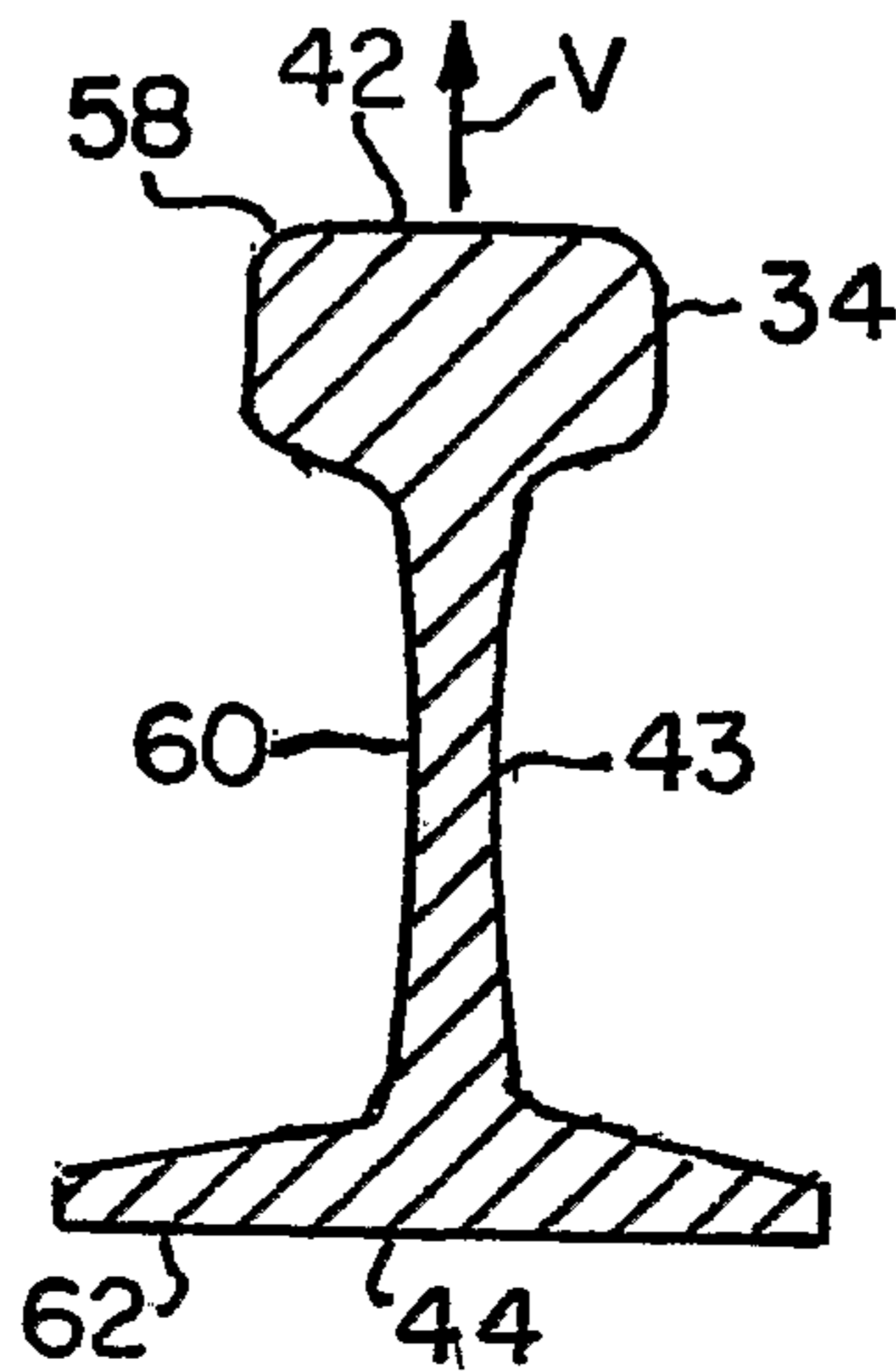

FIG. 3H

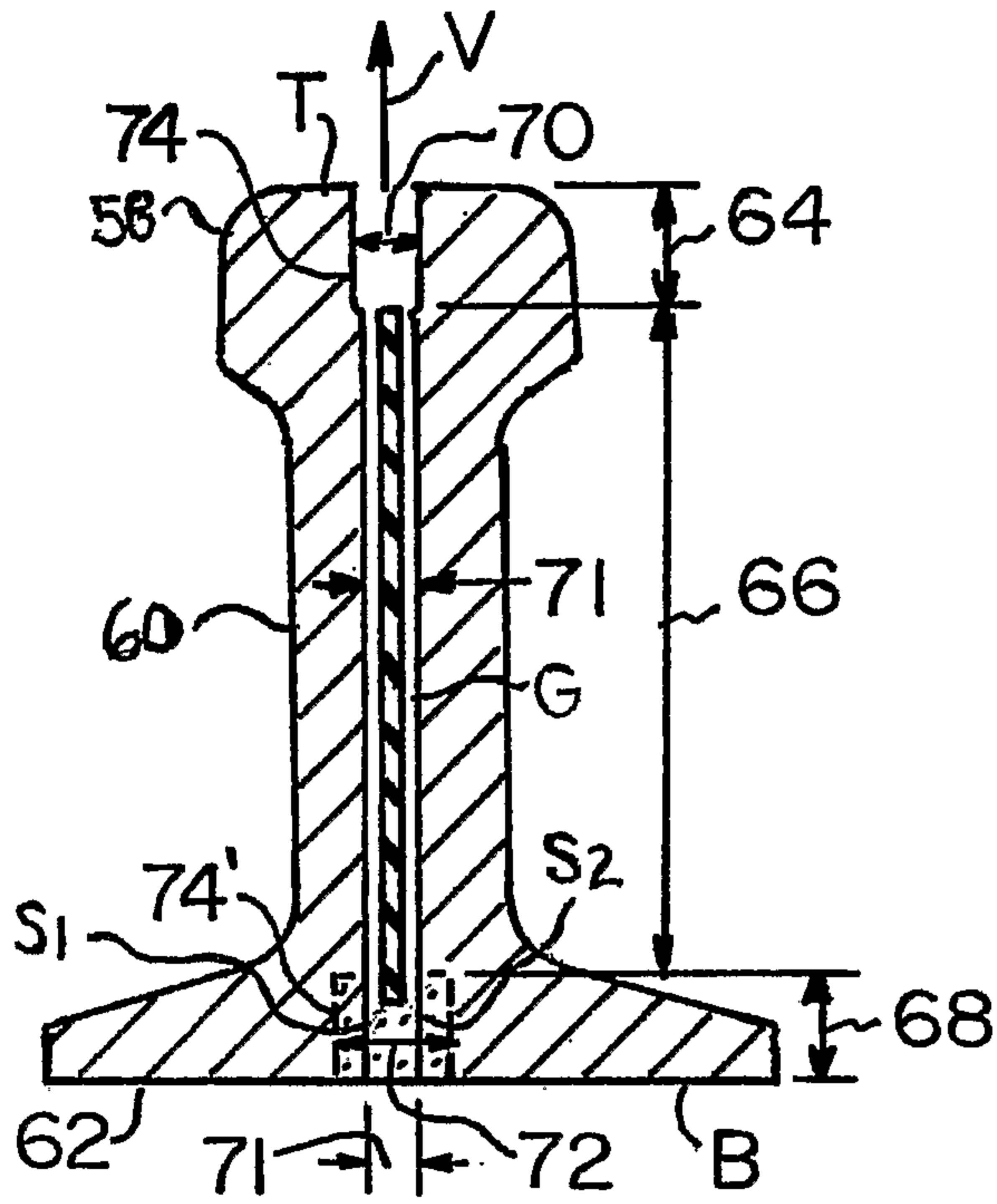

FIG. 4

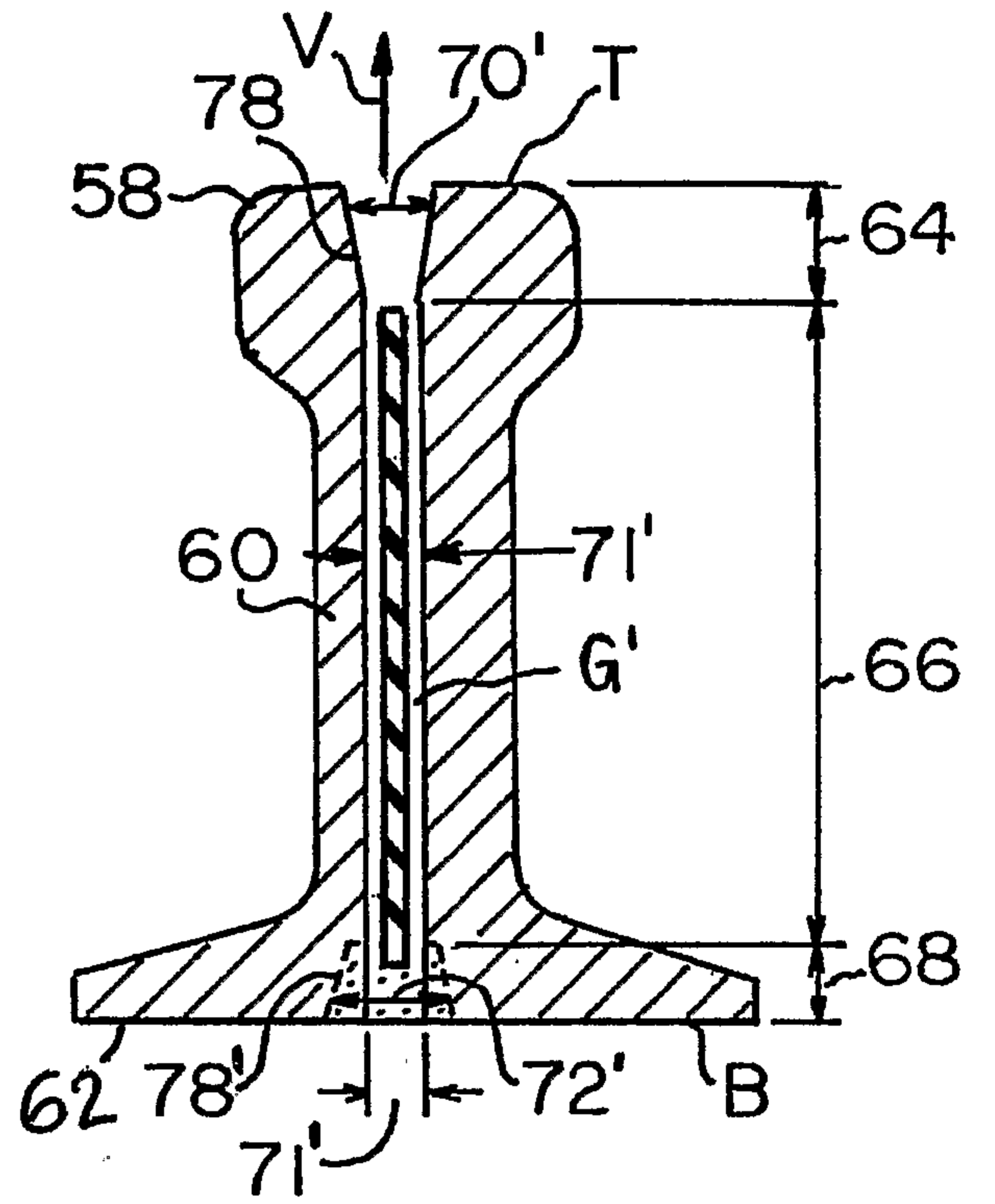

FIG. 5

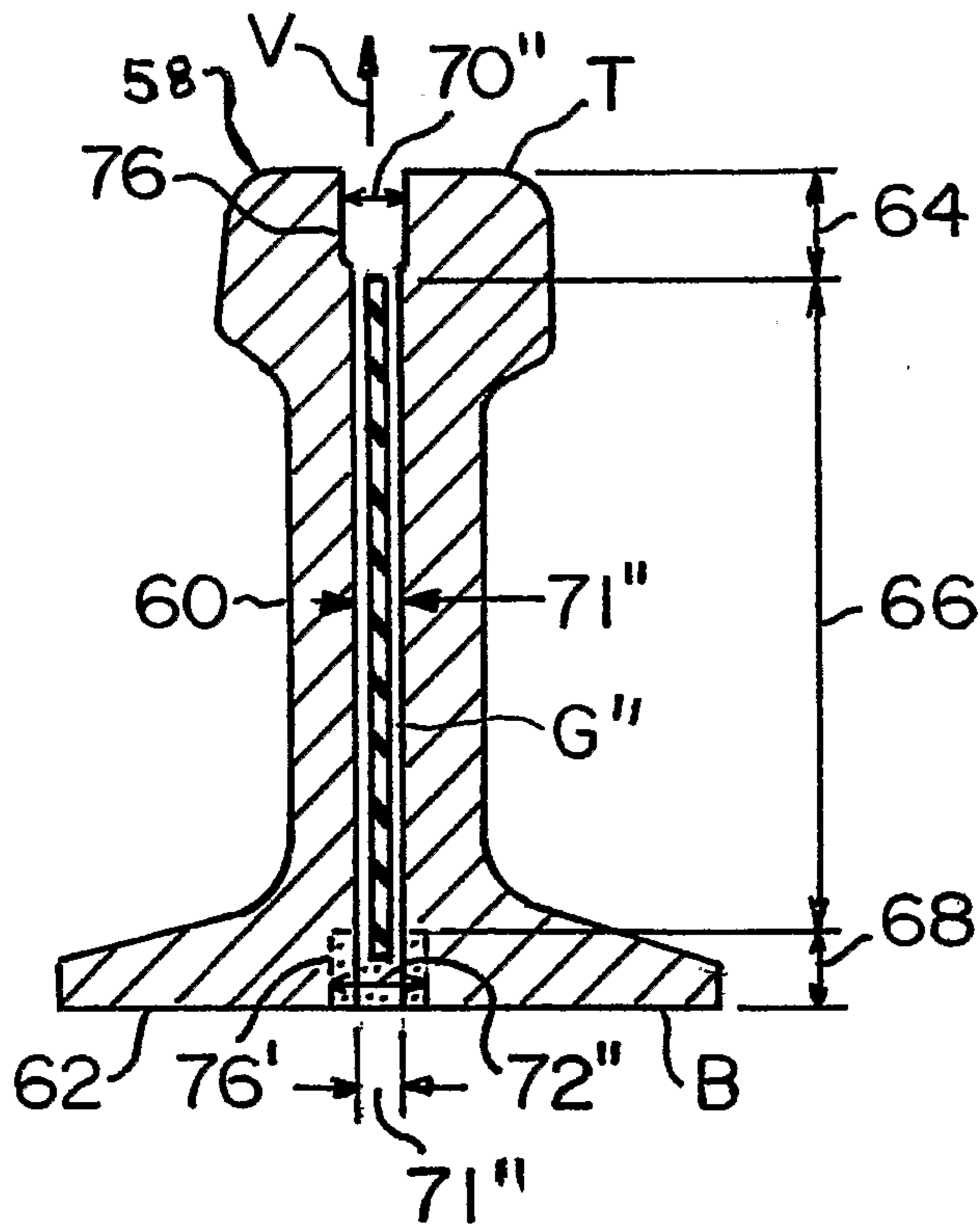

FIG. 6

4 / 5

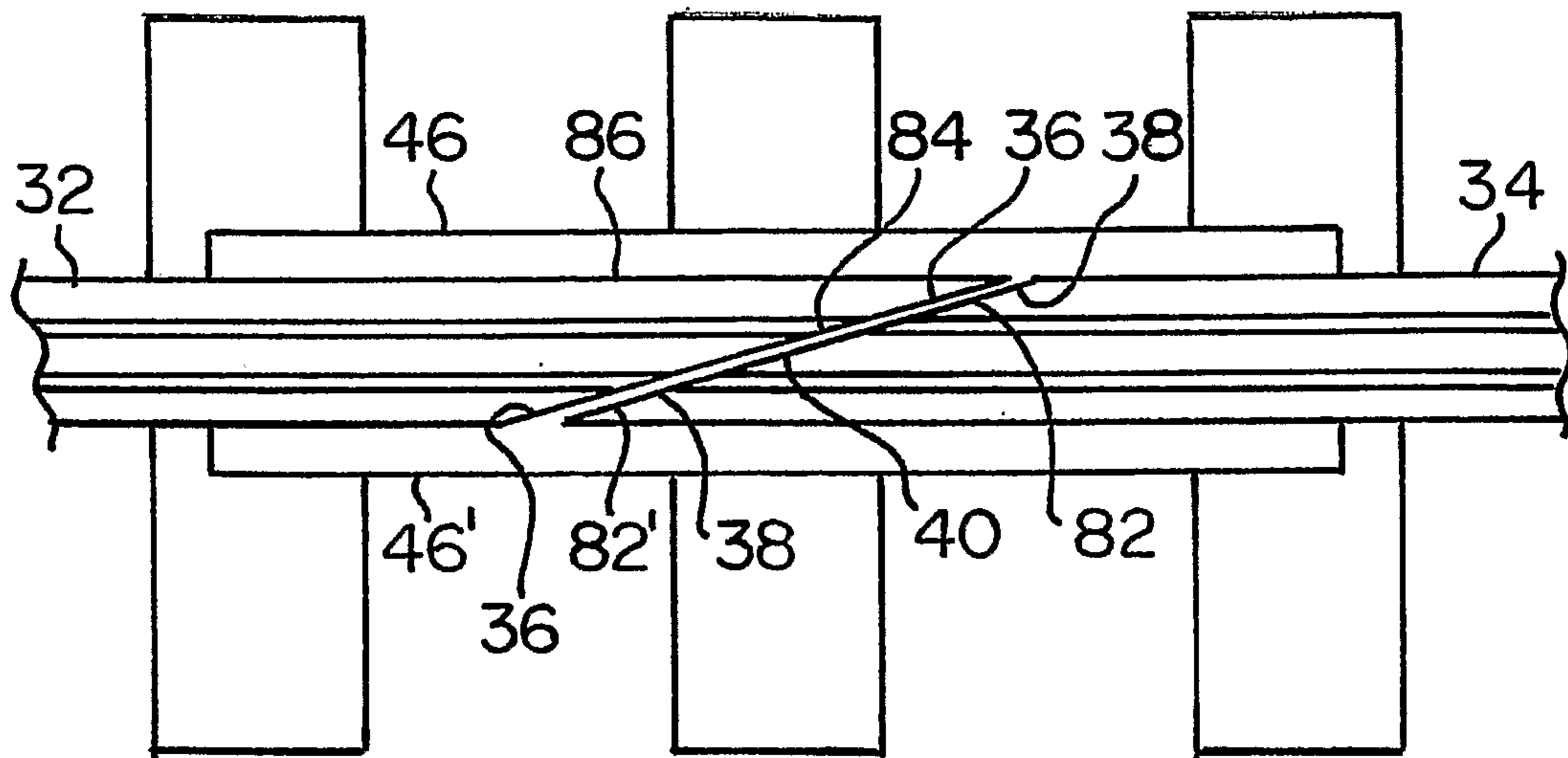

FIG. 7A

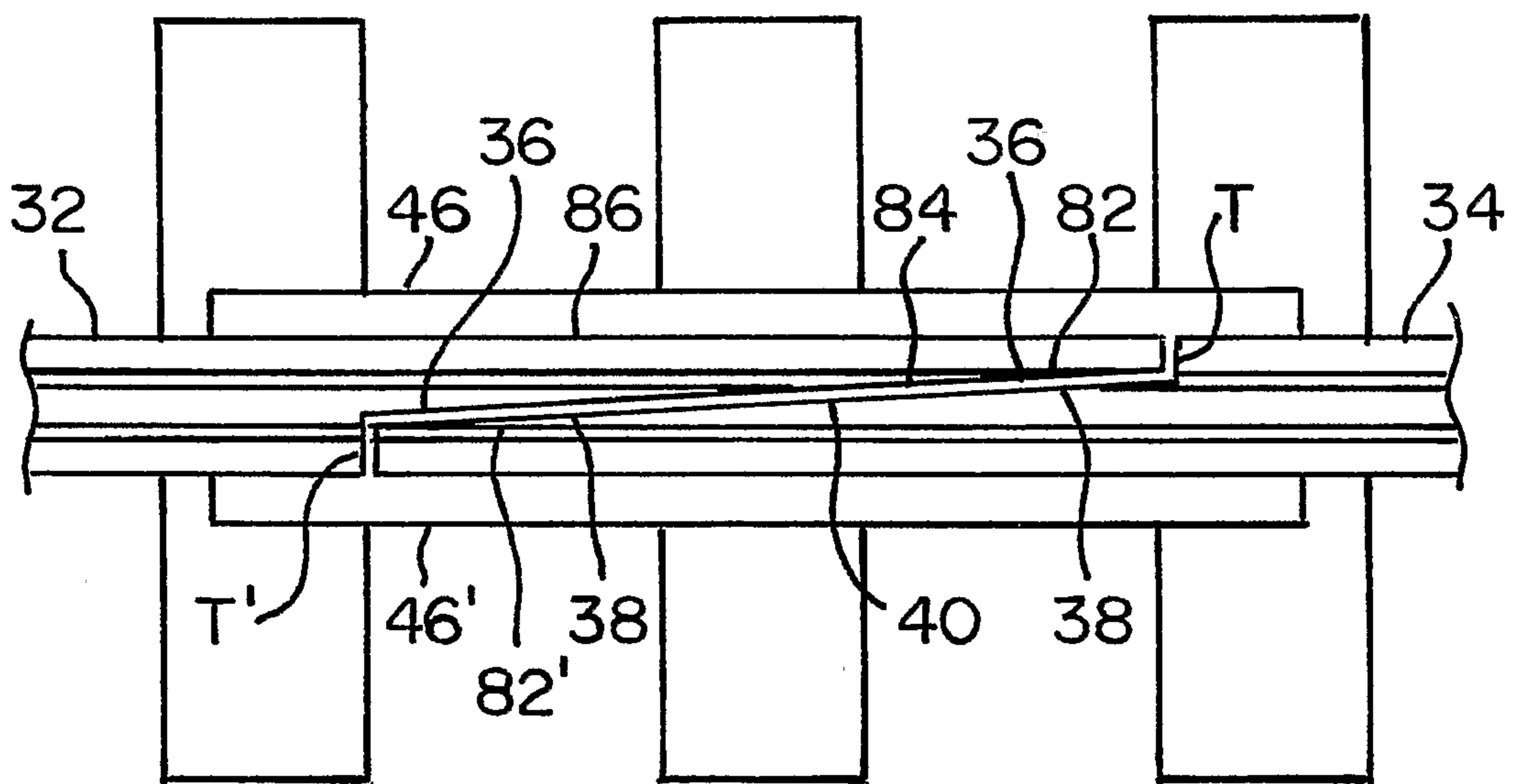

FIG. 7B

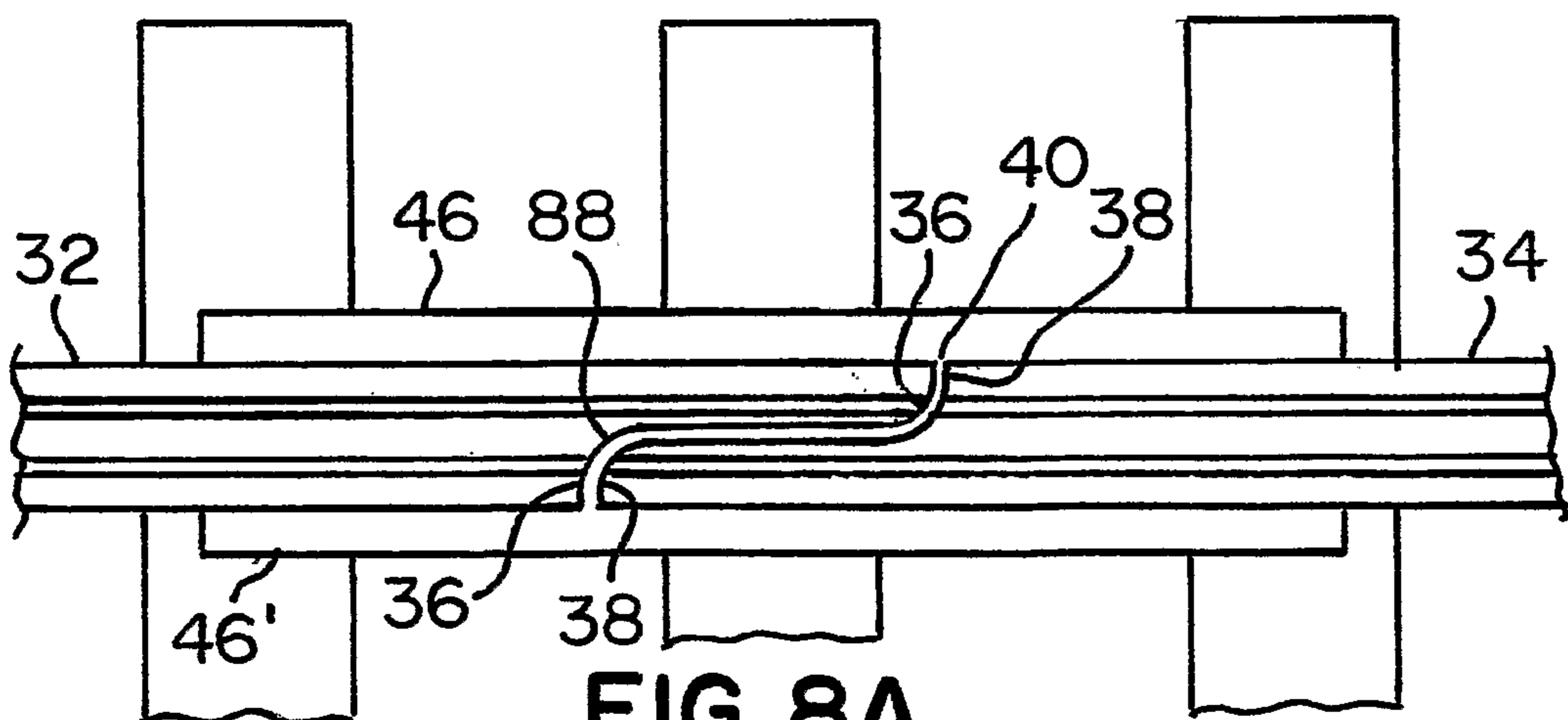

FIG. 8A

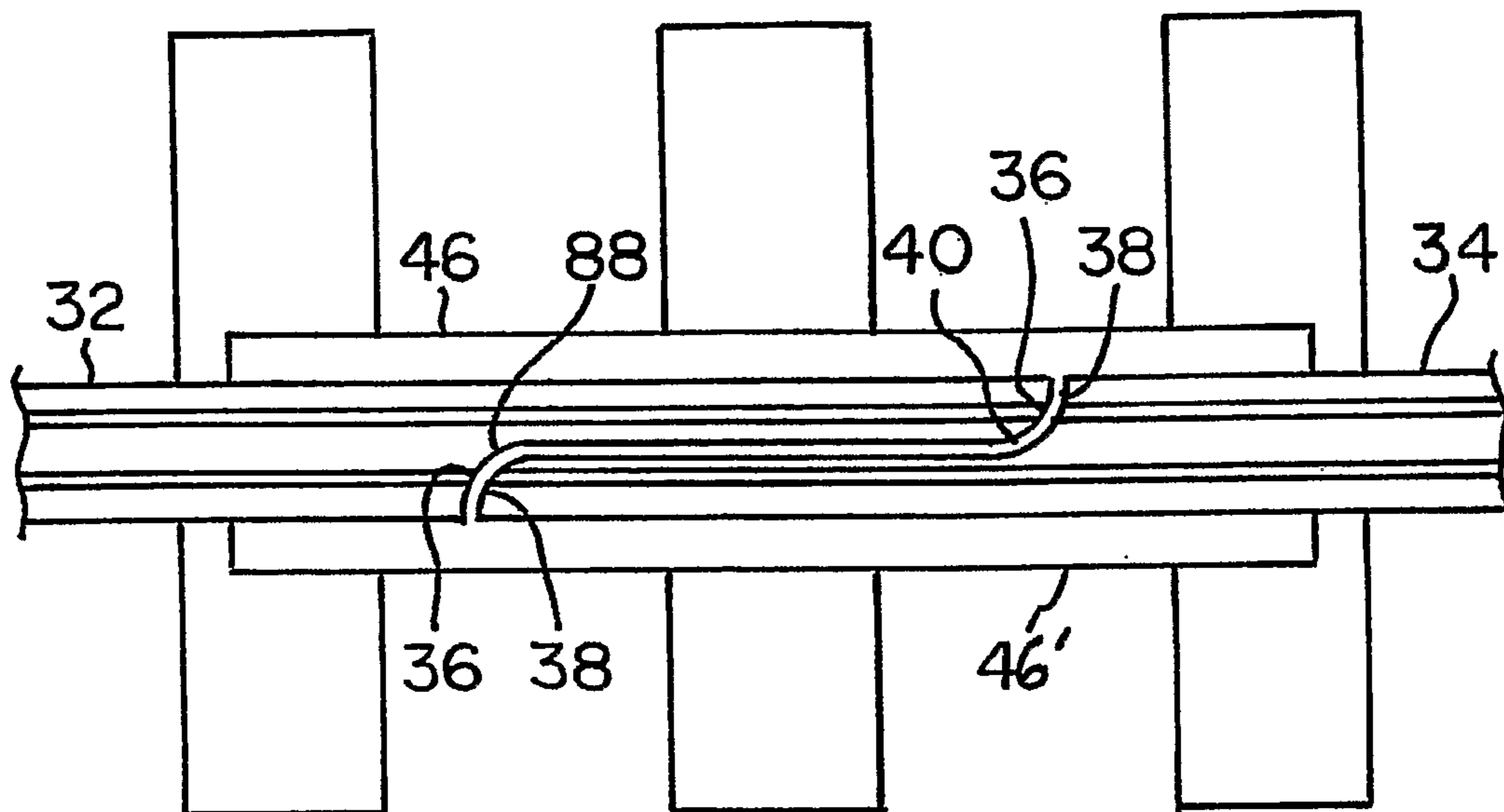

FIG. 8B

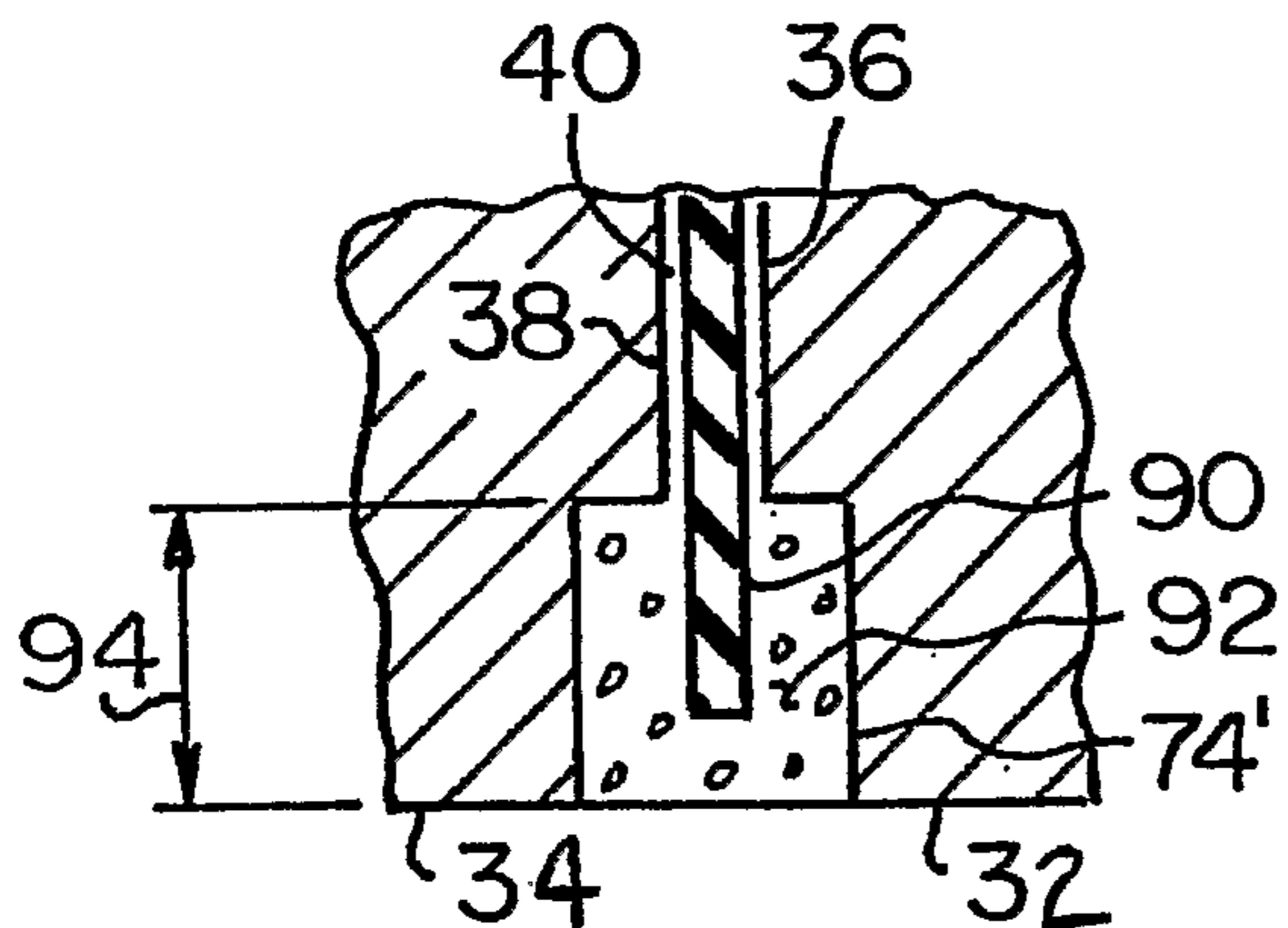

FIG. 9A

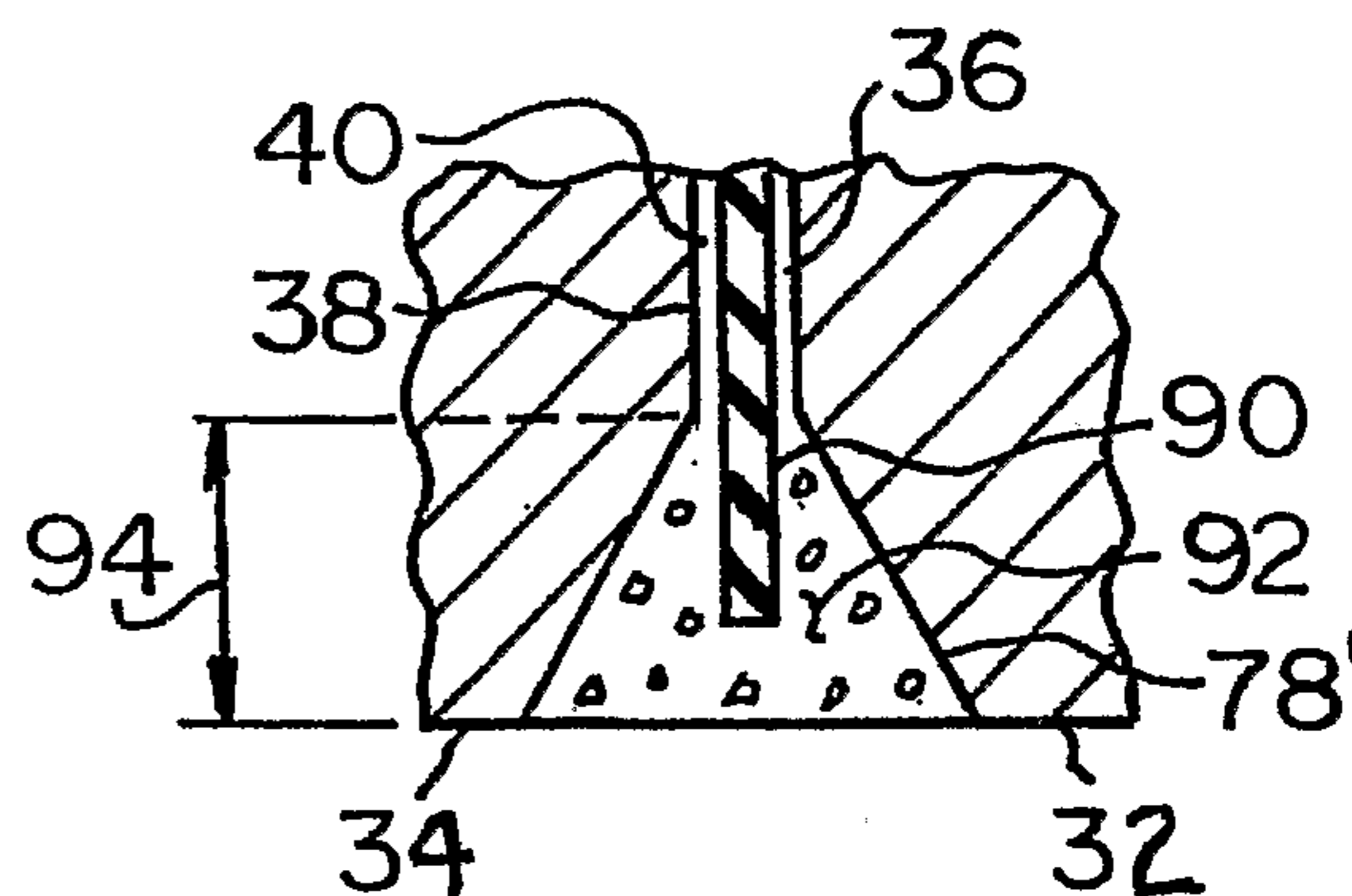

FIG. 9B

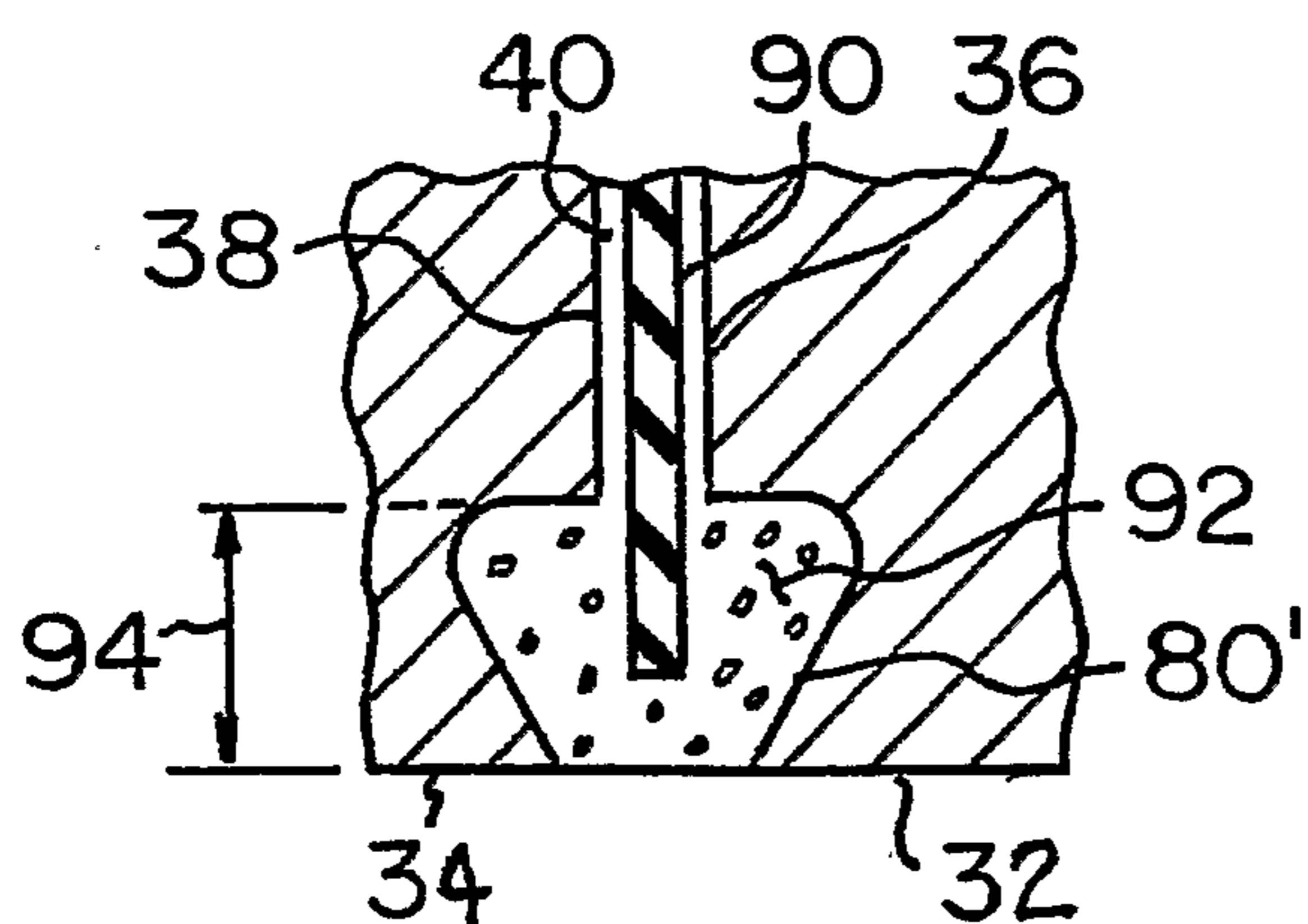

FIG. 9C