



US00D697484S

(12) **United States Design Patent**  
**Kawakami**

(10) **Patent No.:** **US D697,484 S**

(45) **Date of Patent:** **\*\* Jan. 14, 2014**

(54) **ELECTRICAL CONNECTOR**

(75) Inventor: **Yuta Kawakami, Yao (JP)**

(73) Assignee: **Hosiden Corporation, Yao-shi (JP)**

(\*\*) Term: **14 Years**

(21) Appl. No.: **29/415,642**

(22) Filed: **Mar. 13, 2012**

(30) **Foreign Application Priority Data**

Sep. 28, 2011 (JP) ..... 2011-022196

(51) **LOC (10) Cl.** ..... **13-03**

(52) **U.S. Cl.**  
USPC ..... **D13/147**

(58) **Field of Classification Search**

USPC ..... D13/147, 154, 184, 199; 439/62, 79,  
439/108, 180, 159-160, 246, 260, 374, 422,  
439/495, 488, 499, 527, 529, 530, 533,  
439/540.1, 541.5, 607.01, 607.04, 607.05,  
439/607.06, 607.17, 607.21, 607.23,  
439/607.25, 607.34, 607.41, 607.53,  
439/620.06, 620.21, 620.31, 660, 668, 676,  
439/680, 892, 894

See application file for complete search history.

(56) **References Cited**

**U.S. PATENT DOCUMENTS**

D470,110 S \* 2/2003 Yamane ..... D13/147  
D564,970 S \* 3/2008 Higuchi et al. .... D13/147

(Continued)

*Primary Examiner* — Daniel Bui

(74) *Attorney, Agent, or Firm* — Kratz, Quintos & Hanson,  
LLP

(57) **CLAIM**

The ornamental design for an electrical connector, as shown and described.

**DESCRIPTION**

FIG. 1 is a front elevational view of an electrical connector according to the present invention;  
FIG. 2 is a back elevational view thereof;  
FIG. 3 is a top plan view thereof;  
FIG. 4 is a bottom plan view thereof;  
FIG. 5 is a right side elevational view, the left side elevational view being a mirror image thereof;  
FIG. 6 is a top, front, and right side perspective view thereof;  
FIG. 7 is a top, back, and left side perspective view thereof;  
FIG. 8 is a bottom, front, and left side perspective view thereof;  
FIG. 9 is a bottom, back and right side perspective view thereof;  
FIG. 10 is a cross sectional view thereof, taken along the line 10-10 in FIG. 2;  
FIG. 11 is a cross sectional view thereof, taken along the line 11-11 in FIG. 2;  
FIG. 12 is a cross sectional view thereof, taken along the line 12-12 in FIG. 1;  
FIG. 13 is a cross sectional view thereof, taken along the line 13-13 in FIG. 4;  
FIG. 14 is a front elevational view thereof in closed condition;  
FIG. 15 is a back elevational view thereof in closed condition;  
FIG. 16 is a top plan view thereof in closed condition;  
FIG. 17 is a bottom plan view thereof in closed condition;  
FIG. 18 is a right side elevational view thereof in closed condition, the left side elevational view being a mirror image thereof;  
FIG. 19 is a top, front, and right side perspective view thereof in closed condition;  
FIG. 20 is a top, back, and left side perspective view thereof in closed condition;  
FIG. 21 is a bottom, front, and left side perspective view thereof in closed condition;  
FIG. 22 is a bottom, back, and right side perspective view thereof in closed condition; and,  
FIG. 23 is a cross sectional view thereof, taken along the line 23-23 in FIG. 14.

**1 Claim, 23 Drawing Sheets**

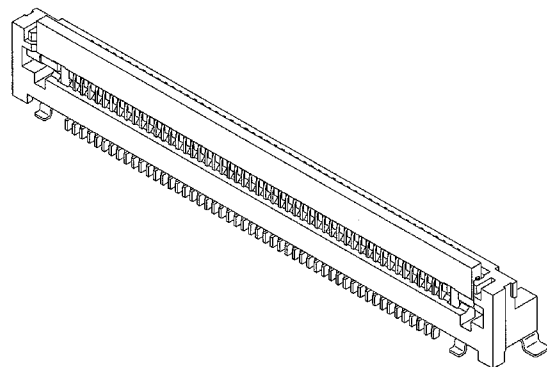
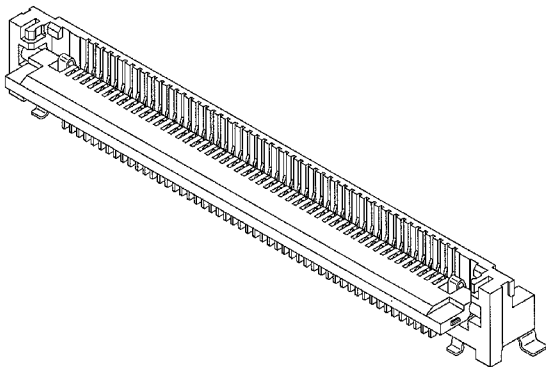

# US D697,484 S

Page 2

---

(56)

## References Cited

### U.S. PATENT DOCUMENTS

D669,860 S *	10/2012	Sasaki .....	D13/147	D673,505 S *	1/2013	Matoba et al. ....	D13/147
D670,252 S *	11/2012	Sasaki .....	D13/147	D677,226 S *	3/2013	Matoba et al. ....	D13/154
				D684,123 S *	6/2013	Matoba et al. ....	D13/154

\* cited by examiner

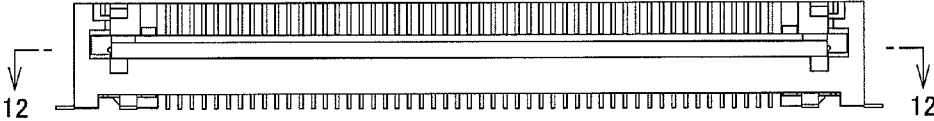

FIG. 1

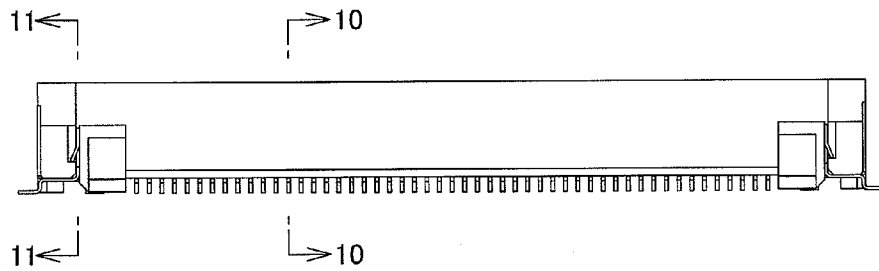

FIG. 2

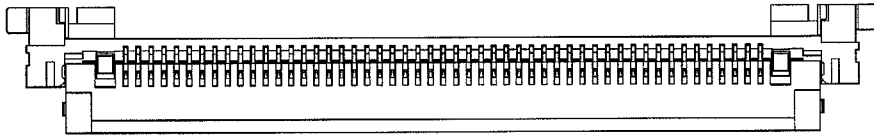

FIG. 3

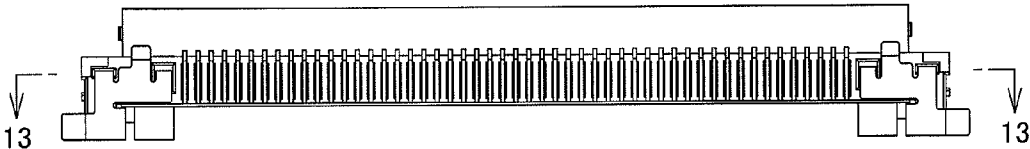

FIG. 4

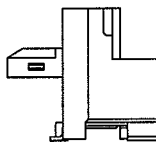

FIG. 5

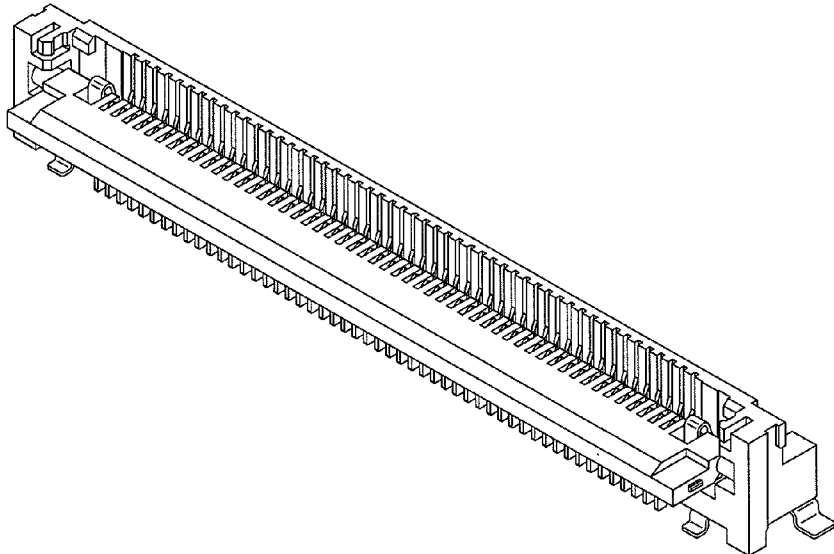

FIG. 6

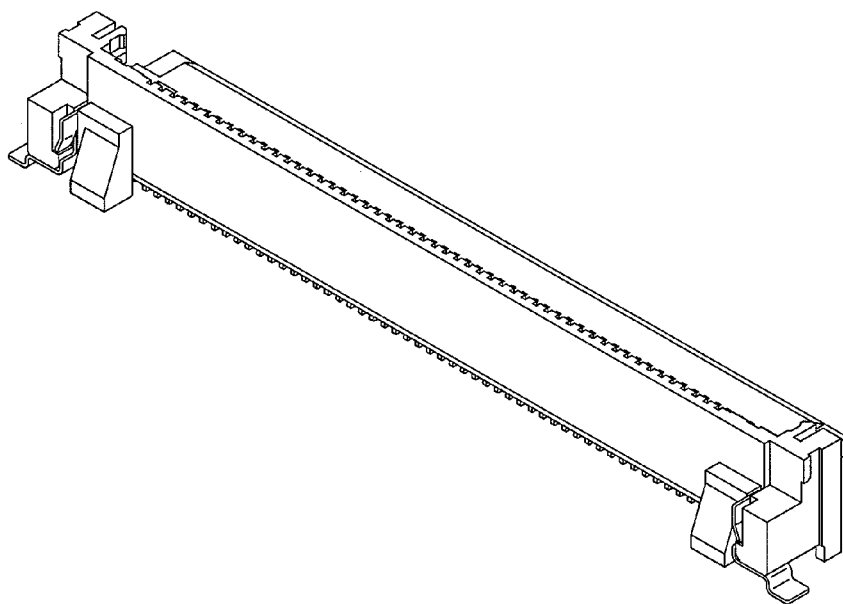

FIG. 7

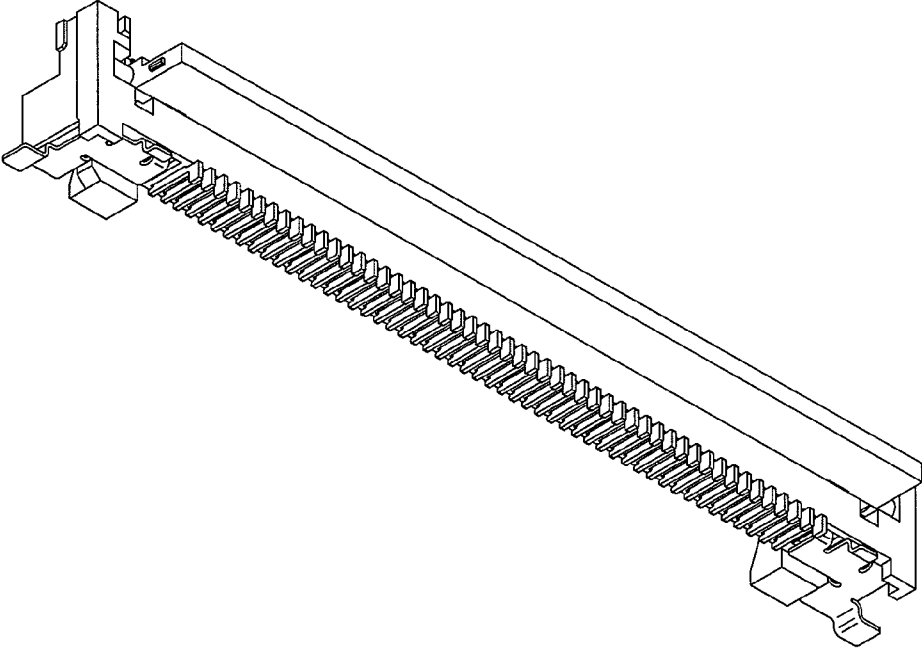

FIG. 8

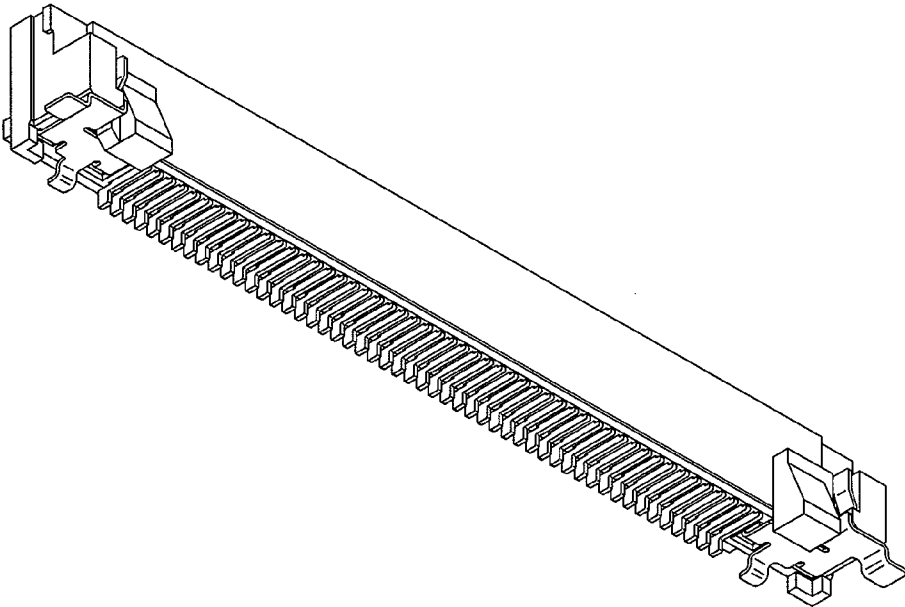

FIG. 9

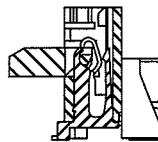

FIG. 10

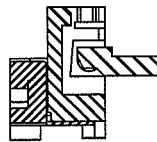

FIG. 11

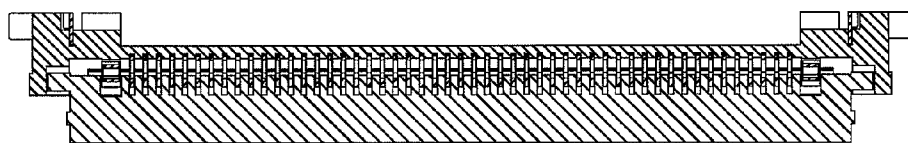

FIG. 12

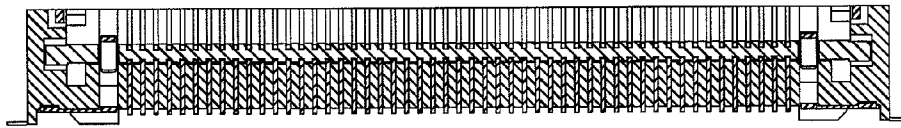

FIG. 13

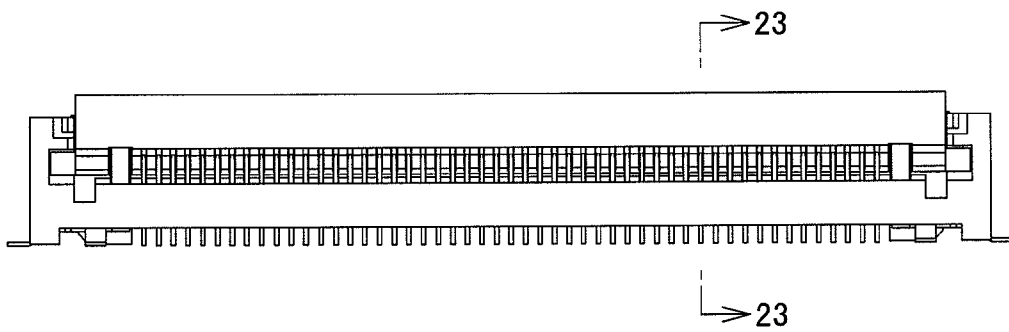

FIG. 14

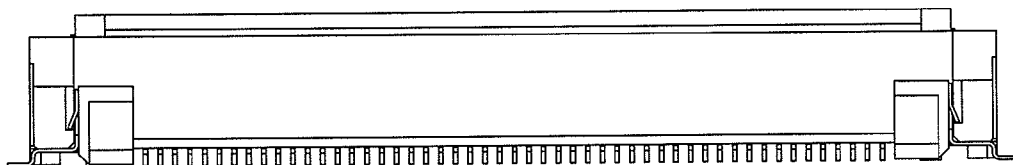

FIG. 15

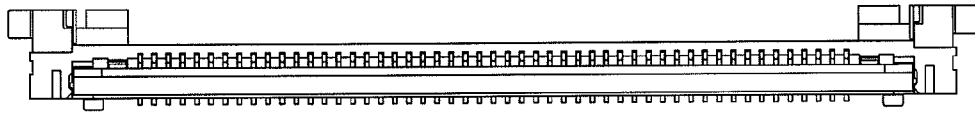

FIG. 16

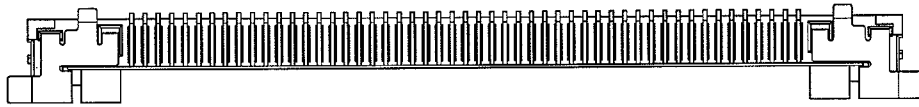

FIG. 17

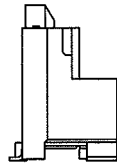

FIG. 18

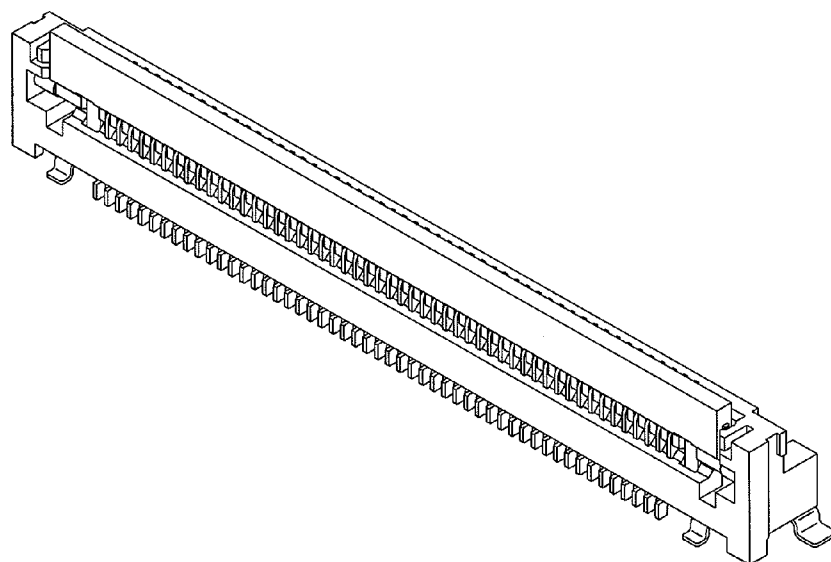

FIG. 19

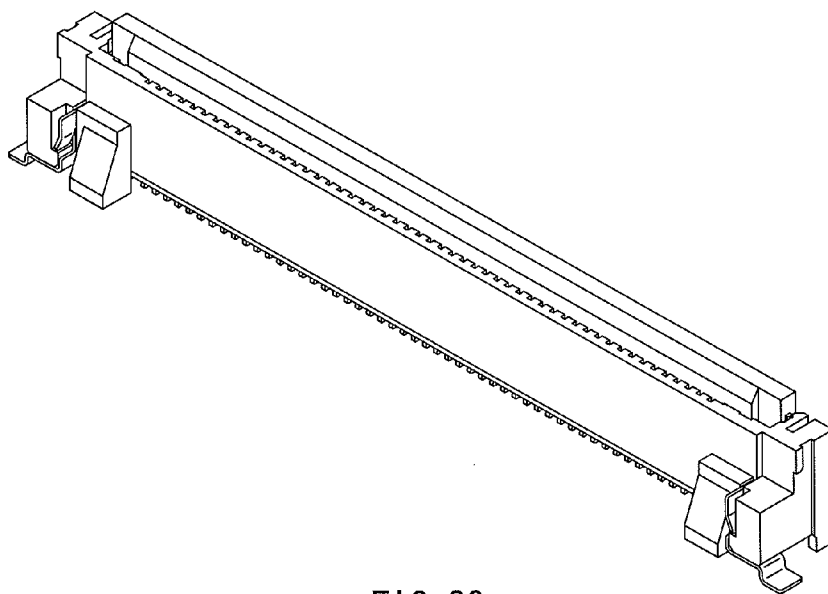

FIG. 20

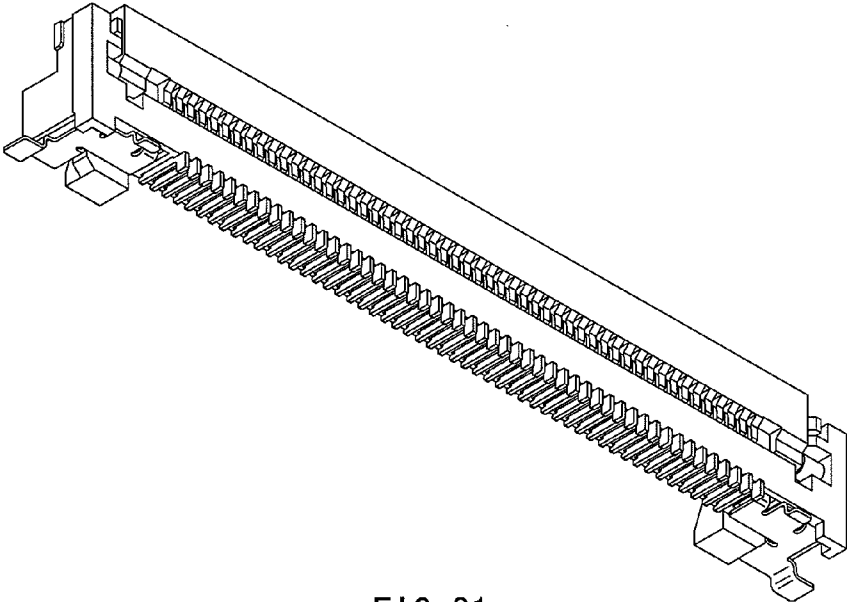

FIG. 21

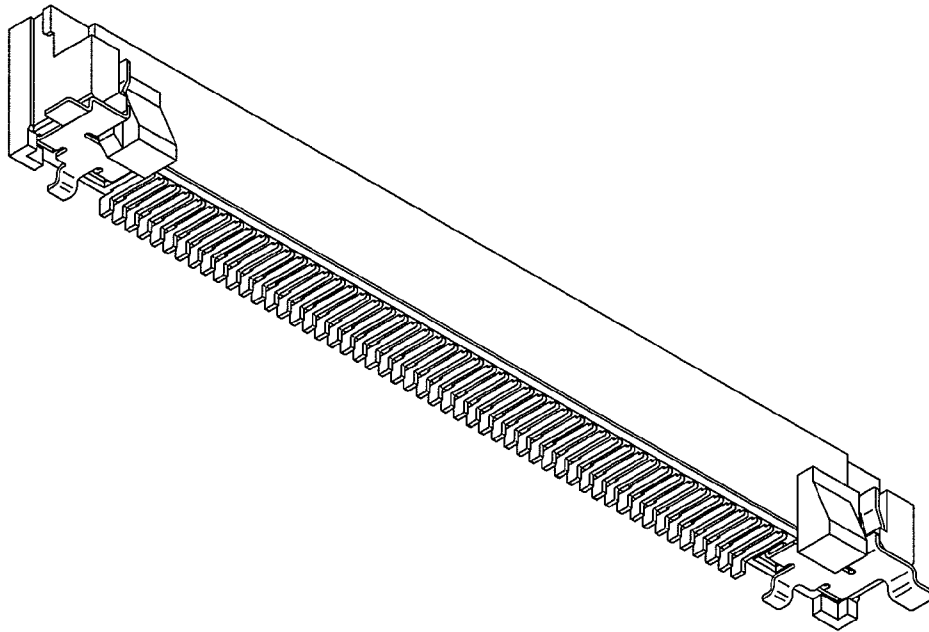

FIG. 22

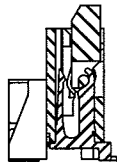

FIG. 23