



, 1 , 2 , ,

2 . ,

가 가 .

. 3 (seize) 가 , 3 가

2 . ,

2 (floating)  
(spring loaded plunger) 2

1

2a

2b 2a

3a

3b 3a

4

5

2 , 3 4 (prong)  
(lip)

3 4 가 가 2 ,  
가 가 가 가

1 , (18, 20) (12), (14), (16)  
(10) (22) (12) 가  
(24) (14) 가 (24) (26)  
(22) (28) , (22) (28) (10) (32, 34)  
(30, 28) , (36, 38) (36, 38) 가 (32, 34)  
(40, 42) (34) ( )  
(32) ( ) (44) (46) (16)  
( )

2a 2b , (22) (10) (28)  
(50) (22) (10) (22) (48)  
(22) 10.8 mm(0.425 inch) 11 mm(0.435 inch)  
(22) (51) (51) ( )  
(28) (28) (10)  
2a 2b , 4  
2 , 3 4 (22) 가  
(16) ( )

, (22) (12) (10) , (28) (10)  
 . (26) (10) (24) (30)  
 . ( ) 가 가 , (22) (28)  
 (26) , (24) (24)

3a 3b , (24) (53) (55)  
 (53) . (24) (52) (54)  
 . (52) (53) (52) 0.216 mm(0.0085 inch) 2.4  
 1 mm(0.095 inch) (10) (54) (30) (10)  
 3a 3b 30), (32) (40) 가 .  
 , 4 2 , 3 4  
 , (22) (50) 3a 3b ,  
 (53) (50) 2a 2b  
 , (55)가 .

4 , (56) (22) (48)  
 . (58) (22) (53) (14)

5 , (62) (60)가 (60)  
 (64) ( ) (46) (68), (66) (72)  
 ( ) (66) . (38) ( )

(57)

1.

1 2 1 1 1 1  
 3 2 1 , 1 1  
 1 1 1 1 가 ,  
 2 2 가 ,  
 1 가 1 , 1 2  
 1 ,  
 2 가 2 , 2 2  
 2 ,  
 1 2

2.

,

1 2 1 1 1 1

3 2 1 , 1 1

1 1 1 1 가 ,

1 2 2 2 가 ,

1 가 1 , 1 2

1 2 가 2 , 2 2

2 2

1 2

3.

1 , 1 가 4 1 , 2 가

4 2 .

4.

2 , 1 가 4 1 , 2 가

4 2 .

5.

1 , 1 .

6.

2 , 1 .

7.

1 , 2 .

8.

2 , 2 .

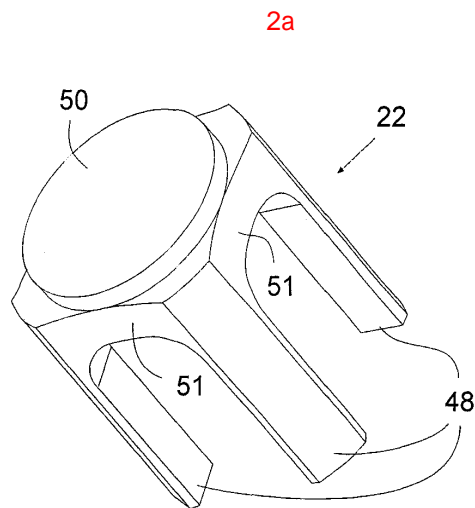
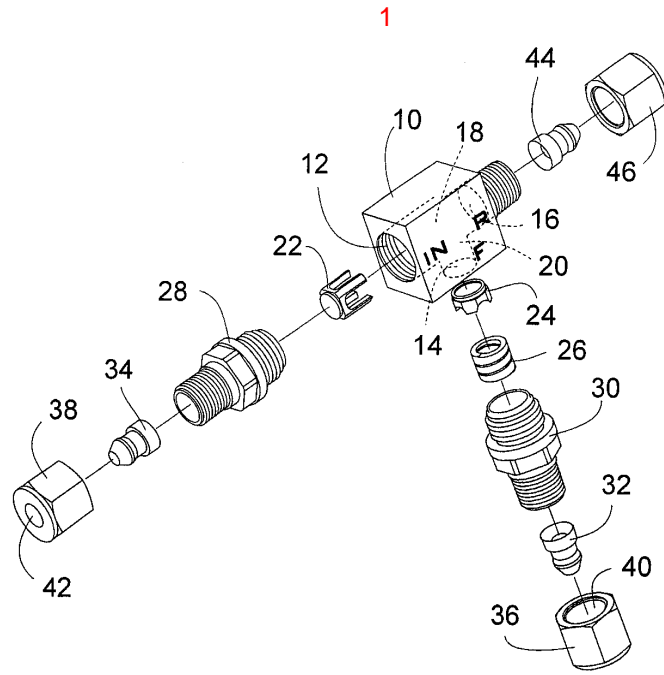

2b

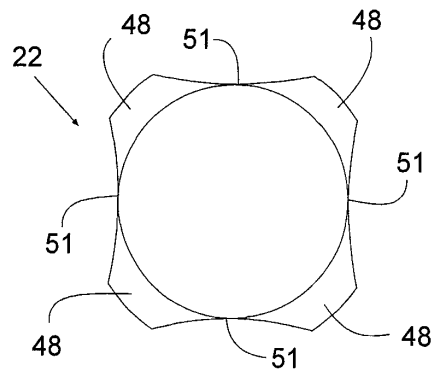

3a

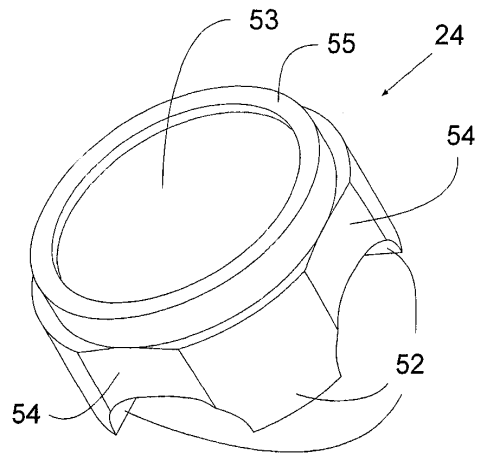

3b

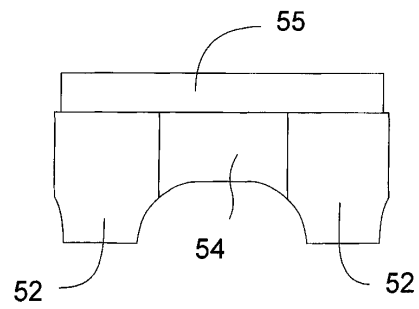

4

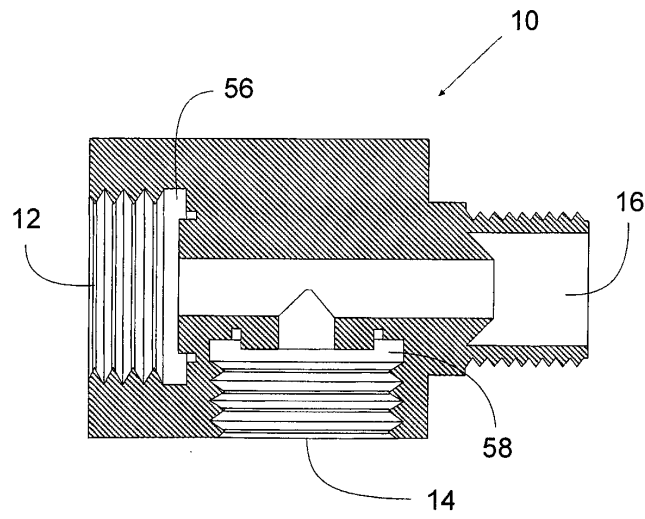

5

