

(No Model.)

2 Sheets—Sheet 1.

W. H. DRAKE & J. C. GREEN.  
FIRE GRATE.

No. 527,778.

Patented Oct. 23, 1894.

Fig. 1

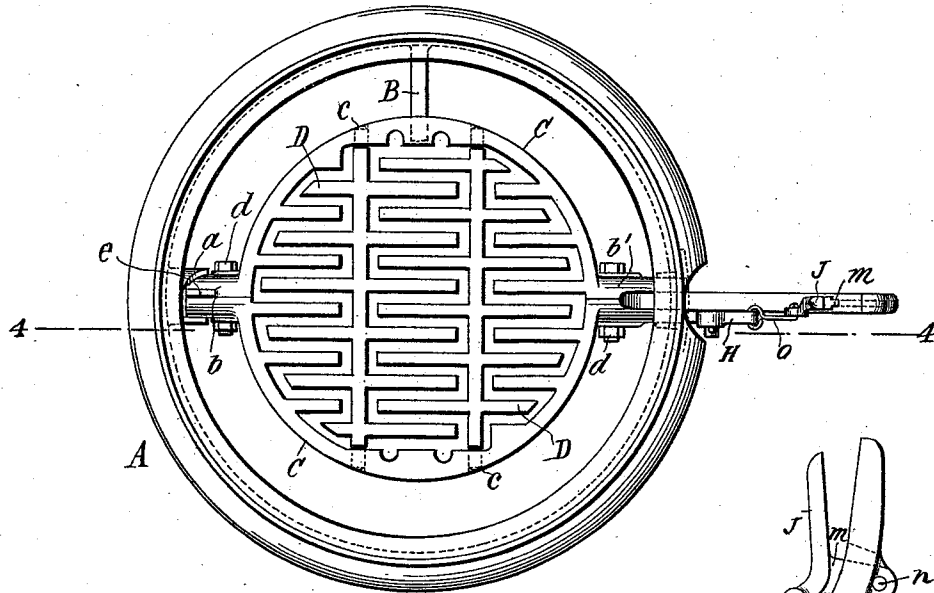
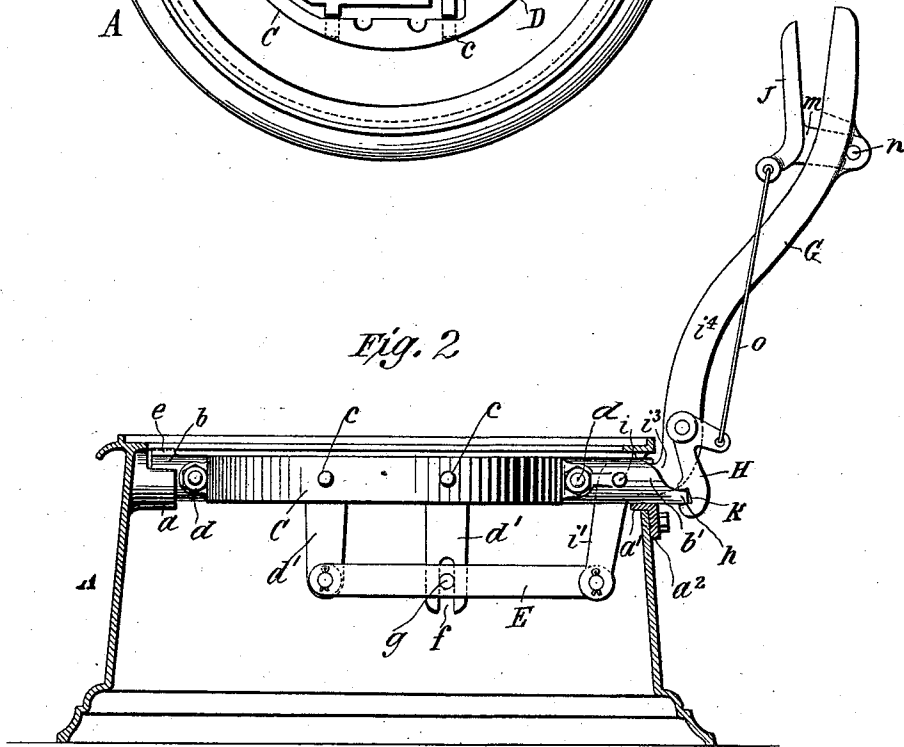

Fig. 2



Witnesses:  
*Raphael Netter*  
*W. C. Pinckney*

Inventors:  
*William H. Drake*  
*John C. Green,*  
*J. M. Bowen*  
 Attorney.

W. H. DRAKE & J. C. GREEN.  
FIRE GRATE.

No. 527,778.

Patented Oct. 23, 1894.

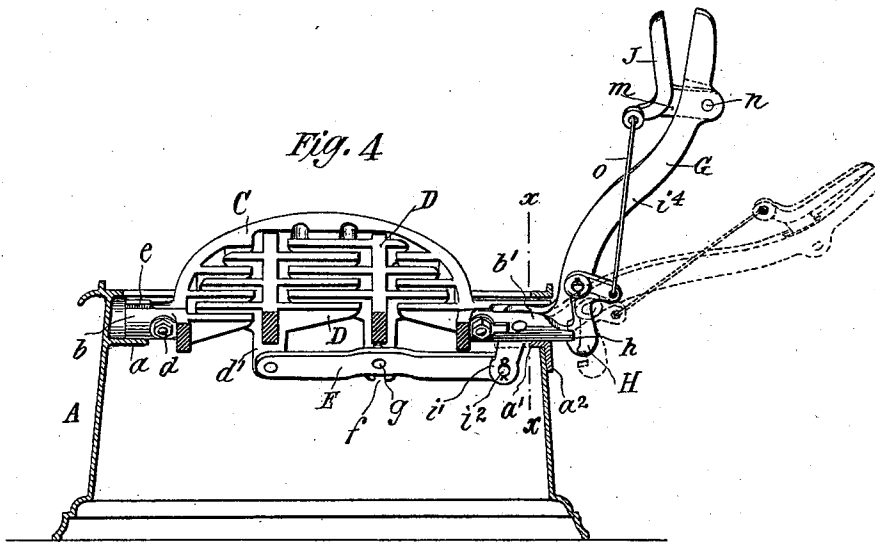
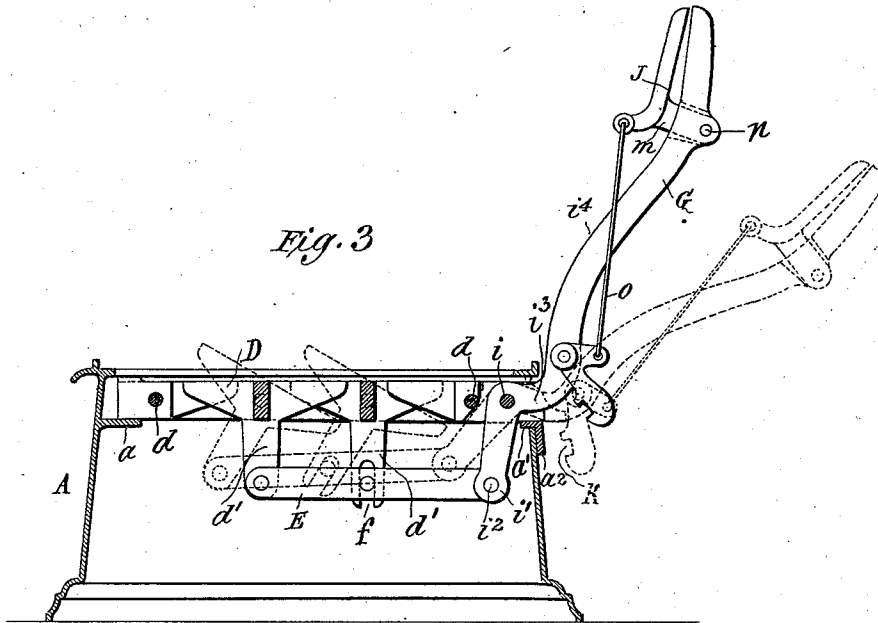

*Fig. 5*

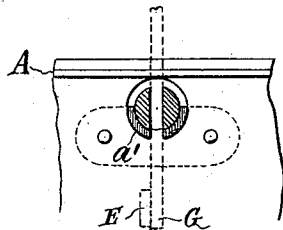

Witnesses:  
*Raphael Netter*  
*W. C. Pinckney*

Inventors:-  
*William H. Drake*  
*John C. Green,*  
*J. M. Bowen*  
 Attorney.

# UNITED STATES PATENT OFFICE.

WILLIAM H. DRAKE AND JOHN C. GREEN, OF HACKETTSTOWN, NEW JERSEY; SAID GREEN ASSIGNOR TO SAID DRAKE.

## FIRE-GRATE.

SPECIFICATION forming part of Letters Patent No. 527,778, dated October 23, 1894.

Application filed May 18, 1892. Serial No. 433,398. (No model.)

*To all whom it may concern:*

Be it known that we, WILLIAM H. DRAKE and JOHN C. GREEN, citizens of the United States, and residents of Hackettstown, in the county of Warren and State of New Jersey, have invented certain new and useful Improvements in Fire-Grates, of which the following is a specification.

This invention relates to fire grates more especially intended for furnaces for heating purposes, but its application is not intended to be thus limited.

The objects of our invention are to provide improved constructive features in a fire grate capable of being shaken or rocked, as well as dumped, by one and the same lever; to provide in a proper and convenient relation to the operating lever a latch serving to hold the grate bars in a horizontal position and adapted to be operated to release the grate bars to permit them to be rocked by means connected to the main operating lever; also to provide the rockers of a rocking fire-grate with vertical arms or hangers depending beneath the rockers, such of said arms or hangers intermediate of the ends of the horizontal rod—which is connected at one end by a pin or bolt to the lower end of the lever for operating the grate and at its opposite end in a similar manner to an arm or hanger—being provided with slots or notches for connecting them with the actuating rod; also in constructing the outside portion or frame of the fire-grate—that is, that part of the grate minus the rocking bars—in two or more sections which are fastened together by suitable means so that in the act of connecting the sections together the gudgeons of the rockers are secured in their sockets in the grate frame, and that these sections contain outer projections which when joined together form the gudgeons for dumping the grate.

In the accompanying drawings, which form a part of this description, we have illustrated our improvements in the form that at present occurs to us as the best that is adapted for effecting the several results to be secured; but we do not limit ourselves to mere details of construction.

In the drawings, Figure 1 shows a top plan view of a structure, including an ash-pit and

grate, embodying our improvements. Fig. 2 is a vertical sectional view through the ash-pit, showing the grate frame as well as the operating mechanism in full lines. Fig. 3 is a central vertical section taken on a line immediately in front of the operating lever, thus eliminating the extension of the grate frame with which the latch for locking the grate bars in a horizontal position co-acts, and exposing in full view the lower portion of said operating lever; said view also showing in full lines the operating lever and grate bars in their normal positions, as well as said parts in dotted lines in the positions which they assume when the lever is pulled down to rock the grate. Fig. 4 shows a central vertical section through the line 4, 4, of Fig. 1, this view illustrating two positions of the operating lever neither of which is normal, the first position being in full lines and representing said lever pulled forward to dump the grate, the grate being correspondingly elevated at the back, and the second showing in dotted lines, the said lever—after it has been pulled forward to dump the grate—thrown outward to the position it assumes when rocking the grate bars, thus showing the capacity of the organization to permit of the rocking of the grate bars when the grate is dumped or partly dumped. For the sake of clearness the grate bars are not shown in Fig. 4 in dotted lines in the position which they would assume when the operating lever is in the position shown in dotted lines in said figure. Fig. 5 is a cross section on the line *xx* of Fig. 4, a fragment only of the ash-pit being shown.

In our construction, wherein a single operating lever only is required for performing the double function of rocking the grate bars and dumping the grate, the rockers may be operated when the grate is partially dumped, which cannot be done by constructions devised previous to ours.

Referring now to the annexed drawings, A indicates the cast iron ash-pit of the usual construction, provided with bearings *a*, *a'* near its upper edge to receive the gudgeons *b*, *b'* of the grate frame. Bearing *a* is cast integral with the ash-pit while bearing *a'* is a separate piece and has a flange *a<sup>2</sup>* which is bolted onto the outside of the ash-pit as

shown. The bearing *a'* passes through an opening, made in the side of the ash-pit to receive the operating lever. The gudgeon *b'* passes through this opening, resting and operating in bearing *a'*. There is also cast integrally with the ash-pit a stop B upon which the grate frame rests when the grate is in its normal or horizontal position.

The grate frame C, that is that portion of the fire-grate minus the rocking bars, is made in sections. As shown in Fig. 1 this frame is in two parts, though it may be made in more than two parts. Heretofore the outside grate frames have been cast in one piece and generally with surface depressions to receive the gudgeons of the rockers, the gudgeons being let down from the top. By making the grate frame in sections the sockets for the gudgeons of the rockers may be formed in the rim of the frame as indicated at *c* in Fig. 1, and in fastening the sections of the frame together by the bolts *d* which pass through the gudgeons *b b'* of the sectional frame (or other suitable fastening means may be employed), the rockers, which are indicated in the drawings by D, are also secured in place. In this way a substantial structure is secured, as the spindles of the rockers are not liable to become detached from their sockets, or become clogged when the rockers are being operated.

On one of the gudgeons of the frame of the fire grate opposite the gudgeons of said frame which are in proximity to the operating lever, there is formed a stop *e* which is adapted to come in contact with the edge of bearing *a* when the grate is tipped sufficiently, the purpose of said stop being to prevent the grate when dumping the same, from turning too far and thus prevent the pin which secures the operating lever to the actuating rod of the grate from dropping out.

The rockers D are provided with arms or hangers *d'* which depend from the under surface of the rockers as shown in the drawings and which connect with the horizontal rod E to one end of which the lower end of the operating lever is pivoted. The grate of the drawings is shown composed of the grate frame C, C, and two rockers only. In larger sized grates three or more rockers, each with its equipment of grate bars, are made use of, and each rocker is provided with a hanging arm *d'* to connect with the horizontal actuating rod E which is pivoted to the lower end of the operating lever as explained. Whether there be two or more rockers employed in the grate, the hangers *d'* intermediate of the ends of the horizontal bar E are notched or slotted at their extremities as shown at *f* in the drawings, and the horizontal rod E is suitably provided with laterally projecting pins *g* which are adapted to enter the slots *f*, by which means the hangers between the ends of the horizontal rod E are connected to said rod so that they may be rocked by said actuating rod. The lower end

of the operating lever and the rocker farthest removed from said lever are provided with holes to receive bolts or pins which serve to connect the ends of the actuating rod E to said rocker and lever—the hangers of the rockers intermediate of said particular rocker and the foot of the operating lever being operatively in connection with rod E by the notches or slots of said hangers co-acting with the pins *g* in the sides of rod E, as stated.

We are aware that grates have heretofore been devised wherein each hanging arm was provided with a forked lever end, riding upon projections attached to an actuating bar provided with a handle or lever. In our construction we prefer to hinge or pivot the rocking arm farthest removed from the lever or handle to the actuating bar, whereby we insure continuity and strength to the rocking mechanism, and to provide the remaining arms with notches in order to make the grate bars rock freely and to permit of readily detaching the same when desired.

The gudgeon *b'* of the grate frame—one half thereof being formed integral with one section of the grate frame and the other half thereof integral with the other section of said frame—has sufficient space between its parts to permit the passage of the foot of the operating lever therethrough as shown in the drawings, one of the parts of said gudgeon extending outside of the ash-pit frame to provide a lip or stud *h* with which a latch presently referred to co-operates.

In practice, the operating lever G will be substantially of the form shown in Fig. 3, and it is pivoted at *i* between the two sections of the gudgeon *a'*, the said gudgeon furnishing a socket for the same. The foot *i'* of the lever extends downward from the pivot *i* and is pivoted at its lower end to the end of actuating rod E as shown at *i''*. From pivot *i* said lever G is bent outward as at *i'''* and this bent portion of the lever is held by said pivot between the two parts of the gudgeon *b'* of the grate sections, so that in turning the lever to dump the grate, the latter will turn on its gudgeons *b b'* within the sockets *a a'*. The handle *i''* of the lever G extends upward, preferably in a curve to a point where it may be conveniently operated on the outside of the ash-pit. This construction of lever G enables its lower end or foot to be located within the ash-pit while the operating handle is on the outside of the ash-pit. The vertical dimensions of the bend *i'''* of the lever are such that it is adapted to vibrate within the gudgeon *b'* when the lever is thrown outward to operate the rockers D as indicated in Fig. 3, the dotted lines showing the positions assumed by the lever, actuating rod E and rockers when the lever is thrown outward to effect such rocking. While the bend *i'''* of the lever may vibrate in a vertical plane within the gudgeon for the purpose stated, its lateral thickness is such that when fitted within the gudgeon it has no lateral play, so that when

the lever G is tipped or tilted forward, as indicated in full lines Fig. 4, the entire grate is tilted on its gudgeons *b b'*, the gudgeons rolling in the bearings *a a'* which are fixed in or to the ash-pit. It will thus be seen that the rocking and dumping operations are both effected by the same lever and that our construction permits the rockers to be easily operated when the grate has been partially dumped, a capability of our construction not found in fire grates as heretofore made. Fig. 4 illustrates this peculiarity of our invention, the lever G in full lines showing the position it assumes when it has been tipped forward to partially dump the grate—the grate being shown as partially dumped—and the dotted lines indicating the position assumed by the lever when it has been thrown outward or depressed to operate the rockers. The second position of the rockers, which would correspond with the position of the lever in dotted lines, is not shown to avoid confusion of the parts of the view.

To secure the rockers in a horizontal position within the grate frame, we make use of a latch H which is pivoted to the handle of the lever near its lower end as indicated. This latch resembles a bell crank lever one arm of which is longer than the other. It is pivoted to vibrate on the handle of lever G, and its lower arm, which is the longer arm, is notched or slotted on its side near the end, as at *k*, while the extremity of its shorter arm is provided with a hole as shown. The latch H, when the lever G is in its normal position (as shown in Fig. 2), coacts with the lip or projection *h* on gudgeon *b'* to lock the lever G to said gudgeon and thus secure the rockers in their horizontal position. The construction of latch H and the manner of pivoting it to lever G—the larger arm of said latch being the heavier arm which causes it to swing toward the gudgeon as lever G is brought to its normal position—secures the automatic co-operation of the notch *k* with the lip or projection *h* of the gudgeon when the lever is adjusted to restore the normal condition of the grate and rockers. To dump the grate it is not necessary to release the latch H, but to operate the rockers it is essential that the latch should be disconnected from the lip *h* of the gudgeon *b'*, and to accomplish this we pivot near the top of lever G a small handle J the upper part of which extends upward substantially parallel with the end of lever G so as to be conveniently grasped with the lever G by the attendant, while the lower end of said handle J is curved outwardly a short distance and is perforated. The handle J is provided with a part *m* projecting from its back by means of which the handle is pivoted (at *n*) to lever G. The part *m* of this handle may be pivoted to operate in a slot of lever G as shown, or it may be pivoted to the side of said lever. The lower end of handle J is connected to the short arm of latch H by means of a wire or chain *o* as

shown. The manner in which the latch H co-operates with the lip *h* of gudgeon *b'* and the said latch is released from engagement with said lip through the instrumentality of the small handle J, will be fully understood from the drawings and the above description without further explanation. This feature of combining and connecting with the operating lever a second lever operating latch which automatically engages itself with the gudgeon of the grate frame to lock the rockers in their horizontal position when the operating lever is restored to its normal position, and which latch is so combined with means attached to the operating lever as to permit it to be readily disengaged from the gudgeon of the grate—when it is desired to operate the rockers—by the movement of the operating lever that effects the operation of the rockers, is also an important part of our invention.

Having thus described our invention, what we claim as new, and desire to secure by Letters Patent, is—

1. A rocking fire grate having a projection extending outside of the ash pit and a lever for effecting the operation of the rockers, combined with a latch pivoted to the operating lever and adapted to automatically engage with such projection to lock the rockers in a horizontal position when said operating lever is restored to its normal position, substantially as described.

2. A fire grate the frame whereof is made in sections which are provided with sectional gudgeons for dumping the grate and also with gudgeon sockets through their edges and with gudgeons upon which the grate is suspended, combined with rockers whose gudgeons are inserted in the sockets of the grate sections and bolts or other fastening means co-operating with the sectional gudgeons of the grate sections to secure the same together and secure the gudgeons of the rockers in their sockets, substantially as described.

3. The combination with an ash-pit provided with gudgeon bearings, of a rocking fire grate provided with gudgeons operating within said bearings, one of said gudgeons having a lip or lug projecting through the side of the ash-pit, an operating lever pivoted within the last mentioned gudgeon with its lower end within the ash-pit and its upper end outside the ash-pit, an actuating rod for the rockers and a latch pivoted to the operating lever and coacting with the projecting lip or lug of said gudgeon, substantially as described.

4. A rocking fire grate provided with gudgeons suspended in bearings of the ash-pit, one of said gudgeons divided vertically, of an actuating rod for the rockers and an operating lever pivoted within said vertically divided gudgeon with its lower end within the ash-pit and its upper end outside the ash-pit and capable of a movement in a vertical plane on its pivot but prevented from lateral play within the socket furnished by the gudgeon, substantially as described.

5. A fire grate capable of a rocking and dumping motion, combined with a single upright lever for effecting both rocking and dumping operations, said lever passing through and pivoted within one of the gudgeons of the grate frame, which is divided vertically for such purpose, in such a manner that its lower end is within the ash-pit and its upper end or handle outside the ash-pit, substantially as set forth.

6. A fire grate capable of a rocking and dumping motion, combined with a single upright lever for effecting both rocking and dumping operations, said lever passing

through and pivoted within one of the gudgeons of the grate frame in such a manner that its lower end is within the ash-pit and its upper end or handle outside the ash-pit, substantially as set forth.

Signed at Hackettstown, in the county of Warren and State of New Jersey, this 11th day of May, A. D. 1892.

WILLIAM H. DRAKE.  
JOHN C. GREEN.

Witnesses:

WILLIAM A. ACKLEY,  
DAVID M. COOK.