

Feb. 23, 1932.

H. LINDSAY

1,846,524

BOBBIN

Filed Oct. 14, 1929

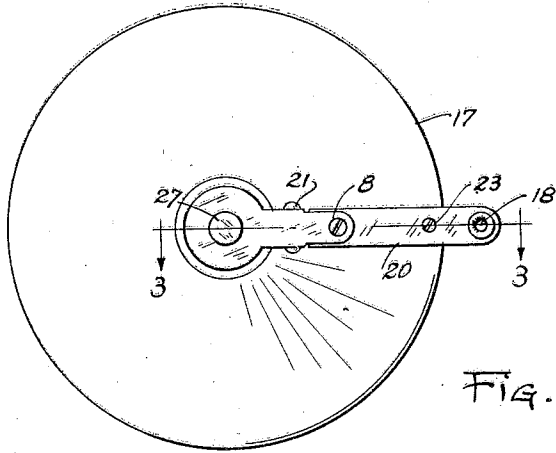

FIG. -1

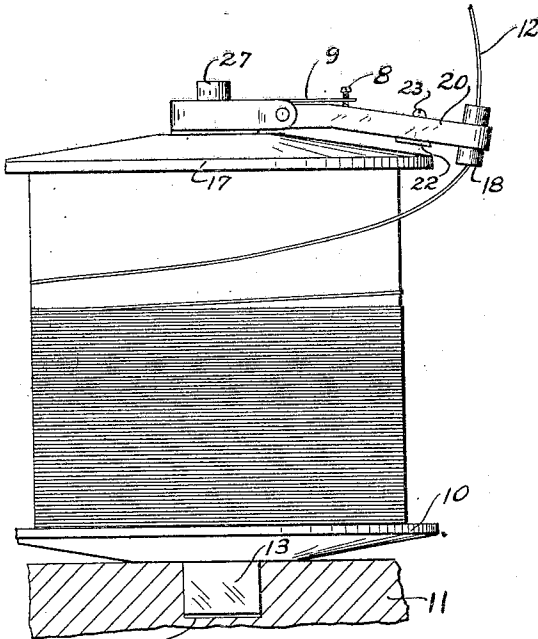

FIG. -2

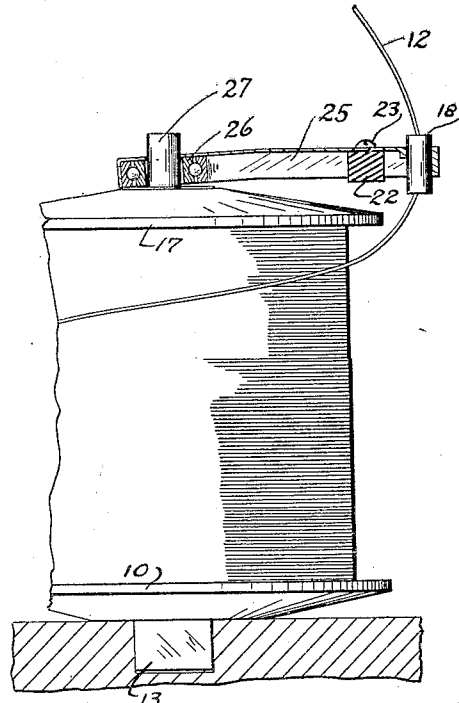

FIG. -4

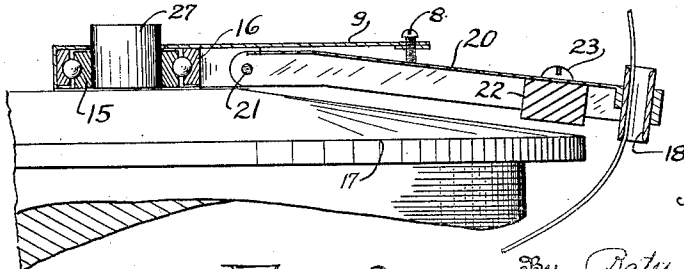

FIG. -3

Inventor

Hamilton Lindsay

By Bates, Golrick & Teare

Attorneys

UNITED STATES PATENT OFFICE

HAMILTON LINDSAY, OF SHAKER HEIGHTS, OHIO, ASSIGNOR TO THE LINDSAY WIRE WEAVING COMPANY, OF CLEVELAND, OHIO, A CORPORATION OF OHIO

BOBBIN

Application filed October 14, 1929. Serial No. 399,533.

This invention relates to apparatus which is used in unwinding wire from bobbins and winding it on to spools. Such operation occurs when the wire on the bobbin is passed through an annealing furnace so as to treat the wire, and to impart desirable physical characteristics to its use in a loom. In practice, the wire moves relatively fast through the furnace, and during such movement is under considerable tension. The wire used is a hard drawn wire, and hence, if a break occurs, the wire is apt to tangle and kink and thus result in loss of time to reset the machine and to eliminate the detrimental part of the wire.

It is impractical to rotate the bobbin during the unwinding operation, as the weight of the bobbin and wire creates an objectionable momentum, which prevents immediate stopping of bobbin rotation as soon as the tension is released. The practice therefore is to utilize an arm which is relatively light in weight and which rotates around the axis of the bobbin, which in turn is positioned vertically upon a support, and which is held in stationary position thereon. The wire, which is withdrawn from the bobbin is threaded through the arm, and then extends through the furnace and onto the spool.

I have found that the use of a rotating arm in connection with a stationary bobbin is not a solution to the problem, as the arm must rotate freely and when so rotated has sufficient momentum to make several revolutions before it is finally brought to rest upon release of the wire tension. As a result, several turns of wire are unwound from the bobbin, and when the machine is again started, the loose wire is apt to become tangled.

The principal object of the present invention therefore, is to provide a mechanism by means of which the wire passing from a bobbin is automatically stopped as soon as the tension on the wire is released so as to prevent the unraveling of the wire unnecessarily on the bobbin. In this connection, my invention is directed toward a mechanism which will permit the wire to be unwound from the bobbin at a relatively high rate of speed, and which is capable of being readily attached to

and disengaged from a bobbin, and which is comparatively simple in construction.

One form of apparatus for accomplishing my invention is illustrated in the drawings, wherein Fig. 1 is a top plan view of a bobbin having my invention associated therewith; Fig. 2 is a side elevation of the bobbin and invention; Fig. 3 is an enlarged longitudinal sectional view taken on the line 3—3 in Fig. 1, and Fig. 4 is a side elevation partly in section of a bobbin equipped with a modification of my invention.

My invention is shown only in connection with a bobbin 10 which is mounted on a rack 11, it being understood that the wire 12 which leads from the bobbin is intended to be attached to a spool on a winding rack, so as to place tension on the wire while it is being payed out from the bobbin. The bobbin is shown, as having the hub 13, which fits into a socket 14 on the bobbin rack, and by means of which the axis of the bobbin is disposed in an upright position. The upper hub 27 of the bobbin may comprise a plurality of yieldable fingers, which are arranged in the form of a cylinder, and onto which the inner race 15 of a ball-bearing journal may be rigidly held. The outer race 16 of the journal is attached to an arm, which extends radially and projects beyond the periphery of the top flange 17 of the bobbin. The outer end of the arm has a passageway 18 through which the bobbin wire is arranged to pass, as it is being payed out.

I arrange the arm so as to provide slight relative motion vertically between the outer end of the arm and the bobbin flange, and I utilize such relative motion for automatically stopping the rotation of the arm about the bobbin, as soon as the wire tension is released.

One form of the invention is shown in Figs. 2 and 3, wherein the outer part 20 of the arm is pivotally mounted at 21, to an inner part, which carries the outer raceway 16. The pivotal connection permits the outer part of the arm to be moved with reference to the inner part, merely by the friction of the wire through the passageway 18. Thus when tension is placed upon the wire, the outer end is

raised and when tension is released, the arm is allowed to drop. The movable part of the arm carries a shoe 22 which may comprise a piece of leather that is fastened to the arm, as by a securing member 23. The shoe projects sufficiently below the bottom of the arm to engage the bobbin flange when the wire tension is released, and yet to clear the flange when the wire is under tension. The frictional contact between the brake and flange is sufficient to stop the immediate rotation of the arm, wherefore the wire is prevented from further unwinding as soon as the tension is released. The brake shoe is lifted from engagement with the bobbin flange, as heretofore stated, by the frictional contact between the wire and the wall of the passageway 18. As the arm revolves relatively fast, the momentum also tends to raise the arm about the pivot 21 and hence, it is desirable to limit the degree of such movement. A convenient way of accomplishing this is to mount an adjusting screw 8 upon a tongue 9 which may form part of a cover for the ball bearing shown in Figs. 2 and 3.

A modification of my invention is shown in Fig. 4, wherein the arm 25 is what may be termed a two-piece construction. The relative vertical motion between the arm and flange is then obtained by employing a relatively loose fit between the inner race 26 and the hub 27. Such relatively loose connection is sufficient to permit the brake to clear the flange, when the wire is under tension.

The arm which I employ in connection with my invention is preferably formed from aluminum and is therefore relatively light in weight. Accordingly, no difficulty is experienced in obtaining an automatic stopping of the arm at the desired time.

I claim:

1. In combination, a bobbin having a length of flexible material thereon, means for holding the bobbin stationary while the material is being payed out therefrom, a hub extending upwardly from the bobbin, a stationary ball race mounted on the hub, a movable ball race surrounding the stationary race, ball bearing members disposed between the races, an arm pivotally mounted upon the outer race and having a passageway disposed adjacent the end thereof through which the material is adapted to pass as it is being payed out from the bobbin and a friction device mounted on the arm and adapted to engage the bobbin, the arm and device being sufficiently light in weight that the normal working tension on the material will move the arm about its pivot and thereby lift the friction device from engagement with the bobbin, and said arm being adapted to drop by gravity into engagement with the bobbin when the tension on said material is released.

2. In combination, a wire carrying spool, means for holding the spool stationary while

wire thereon is being payed out therefrom, an articulated member disposed above the spool, anti-friction means for revolubly supporting the member upon the spool, the wire being adapted to slidably engage the member and to hold it out of contact with the spool during the unwinding operation, and said member being adapted to drop by gravity as soon as the normal unwinding tension on the wire is released, and a friction device carried by the arm and adapted to engage the spool when the member is released.

3. In combination, a wire carrying spool, a wire guiding arm revolubly mounted on the bobbin, said arm comprising an articulated member having one portion thereof relatively fixed against vertical movement with reference to the bobbin and having another portion movable vertically with reference to the bobbin, anti-friction members providing an operative connection between the arm and the bobbin, a friction device associated with the arm and adapted to engage the bobbin upon release of the normal working tension of the wire, and means on one portion of the arm for adjustably limiting vertical movement of the other portion of the arm with reference to the bobbin.

4. A tension device comprising in combination, a wire carrying spool, an articulated arm revolubly mounted thereon, and adapted to be engaged by the wire as it is passing from the spool, said arm being adapted to be lifted from engagement with the spool by the normal tension of the wire as it is payed out from the spool, and being adapted to be dropped by gravity upon release of the normal wire tension and to engage the spool, whereby frictional contact between the arm and spool will stop rotation of the arm substantially simultaneously with the release of the normal wire tension, and an adjustable member mounted on one portion of the arm and adapted to engage another portion thereof, for limiting vertical movement of the arm in one direction with reference to the spool.

5. A tension device, comprising in combination, a wire carrying spool having a hub thereon, an arm extending radially from the spool, ball bearing means operatively connecting the arm to the hub, the outer end of the arm being adapted to be engaged by the wire, as it is being paid out from the spool and being adapted to be lifted out of contact with the spool by the normal wire tension and to be dropped by gravity upon release of such tension, and said arm being adapted when dropped to engage the spool and to prevent movement of the arm with reference to the spool substantially simultaneously with the release of the tension on the wire.

In testimony whereof, I hereunto affix my signature.

HAMILTON LINDSAY.