

(12) STANDARD PATENT
(19) AUSTRALIAN PATENT OFFICE

(11) Application No. **AU 2020475165 B2**

(54) Title
POWER CONVERSION APPARATUS, MOTOR DRIVE APPARATUS, AND REFRIGERATION CYCLE APPARATUS

(51) International Patent Classification(s)
H02M 7/48 (2007.01)

(21) Application No: **2020475165** (22) Date of Filing: **2020.10.26**

(87) WIPO No: **WO22/091184**

(43) Publication Date: **2022.05.05**

(44) Accepted Journal Date: **2024.05.23**

(71) Applicant(s)
Mitsubishi Electric Corporation

(72) Inventor(s)
TAKAHARA, Takaaki;ARISAWA, Koichi;UEMURA, Keisuke;MATSUO, Haruka;MATSUZAKI, Koyo;TAKAHASHI, Kenji;SATAKE, Akira;TOYODA, Hajime

(74) Agent / Attorney
Griffith Hack, Level 15, 376-390 Collins Street, Melbourne, VIC, 3000, AU

(56) Related Art
US 2020/0212818 A1
EP 2667502 A1
EP 3537583 A1

(12) 特許協力条約に基づいて公開された国際出願

(19) 世界知的所有権機関
国際事務局

(43) 国際公開日
2022年5月5日(05.05.2022)



(10) 国際公開番号

WO 2022/091184 A1

- (51) 国際特許分類:
H02M 7/48 (2007.01)
- (21) 国際出願番号: PCT/JP2020/040131
- (22) 国際出願日: 2020年10月26日(26.10.2020)
- (25) 国際出願の言語: 日本語
- (26) 国際公開の言語: 日本語
- (71) 出願人:三菱電機株式会社(MITSUBISHI ELECTRIC CORPORATION) [JP/JP]; 〒1008310 東京都千代田区丸の内二丁目7番3号 Tokyo (JP).
- (72) 発明者:▲高▼原 貴昭(TAKAHARA, Takaaki); 〒1008310 東京都千代田区丸の内二丁目7番3号 三菱電機株式会社内 Tokyo (JP). 有

澤 浩一(ARISAWA, Koichi); 〒1008310 東京都千代田区丸の内二丁目7番3号 三菱電機株式会社内 Tokyo (JP). 植村 啓介(UEMURA, Keisuke); 〒1008310 東京都千代田区丸の内二丁目7番3号 三菱電機株式会社内 Tokyo (JP). 松尾 遥(MATSUO, Haruka); 〒1008310 東京都千代田区丸の内二丁目7番3号 三菱電機株式会社内 Tokyo (JP). 松崎 公洋(MATSUZAKI, Koyo); 〒1008310 東京都千代田区丸の内二丁目7番3号 三菱電機株式会社内 Tokyo (JP). ▲高▼橋 健治(TAKAHASHI, Kenji); 〒1008310 東京都千代田区丸の内二丁目7番3号 三菱電機株式会社内 Tokyo (JP). 佐竹 彰(SATAKE, Akira); 〒1008310 東京都千代田区丸の内二丁目7番3号 三菱電機株式会

(54) Title: POWER CONVERTER, MOTOR DRIVER, AND EQUIPMENT USED IN REFRIGERATION CYCLE APPLIED

(54) 発明の名称: 電力変換装置、モータ駆動装置および冷凍サイクル適用機器

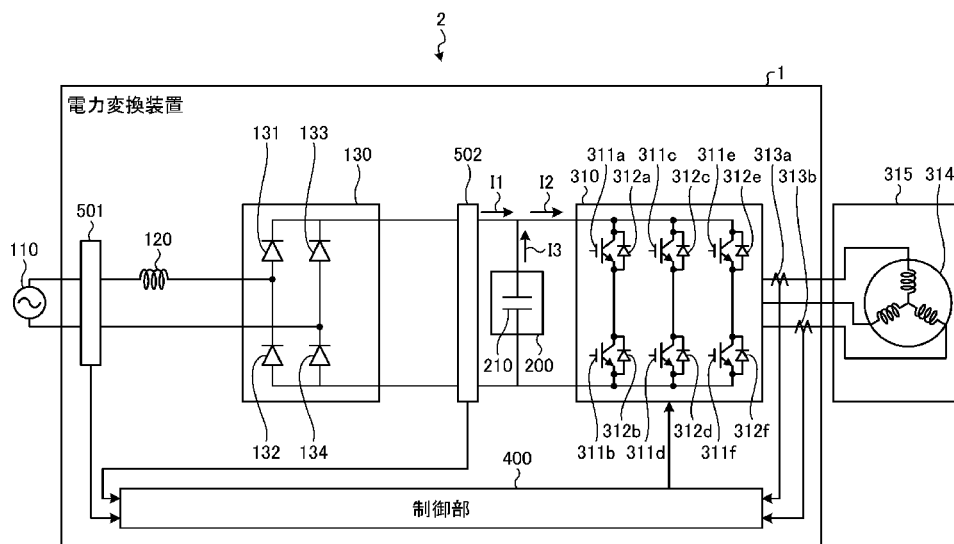

1 Power conversion device
400 Control unit

(57) Abstract: This power converter (1) comprises: a rectifying unit (130) that rectifies first AC power supplied by a commercial power supply (110); a capacitor (210) connected to the output end of the rectifying unit (130); an inverter (310) that is connected to both ends of the capacitor (210), that converts the power outputted from the rectifying unit (130) and the capacitor (210) to second AC power, and that outputs the second AC power to a load having a motor (314); and a control unit (400) that controls the operation of the inverter (310) such that the second AC power, which includes pulsation



WO 2022/091184 A1

社内 Tokyo (JP). 豊田 基(**TOYODA, Hajime**);
〒1008310 東京都千代田区丸の内二丁目7番
3号三菱電機株式会社内 Tokyo (JP).

(74) 代理人: 高村 順(**TAKAMURA, Jun**); 〒1000013
東京都千代田区霞が関3丁目8番1号 虎
の門三井ビルディング 特許業務法人酒
井国際特許事務所 Tokyo (JP).

(81) 指定国(表示のない限り、全ての種類の国内保
護が可能): AE, AG, AL, AM, AO, AT, AU, AZ,
BA, BB, BG, BH, BN, BR, BW, BY, BZ, CA, CH,
CL, CN, CO, CR, CU, CZ, DE, DJ, DK, DM, DO, DZ,
EC, EE, EG, ES, FI, GB, GD, GE, GH, GM, GT, HN,
HR, HU, ID, IL, IN, IR, IS, IT, JO, JP, KE, KG, KH,
KN, KP, KR, KW, KZ, LA, LC, LK, LR, LS, LU, LY,
MA, MD, ME, MG, MK, MN, MW, MX, MY, MZ,
NA, NG, NI, NO, NZ, OM, PA, PE, PG, PH, PL, PT,
QA, RO, RS, RU, RW, SA, SC, SD, SE, SG, SK, SL,
ST, SV, SY, TH, TJ, TM, TN, TR, TT, TZ, UA, UG,
US, UZ, VC, VN, WS, ZA, ZM, ZW.

(84) 指定国(表示のない限り、全ての種類の広域保
護が可能): ARIPO (BW, GH, GM, KE, LR, LS,
MW, MZ, NA, RW, SD, SL, ST, SZ, TZ, UG, ZM,
ZW), ユーラシア (AM, AZ, BY, KG, KZ, RU, TJ,
TM), ヨーロッパ (AL, AT, BE, BG, CH, CY, CZ,
DE, DK, EE, ES, FI, FR, GB, GR, HR, HU, IE, IS, IT,
LT, LU, LV, MC, MK, MT, NL, NO, PL, PT, RO, RS,
SE, SI, SK, SM, TR), OAPI (BF, BJ, CF, CG, CI, CM,
GA, GN, GQ, GW, KM, ML, MR, NE, SN, TD, TG).

添付公開書類:

一 国際調査報告 (条約第21条(3))

corresponding to the pulsation of power flowing from the rectifying unit (130) into the capacitor (210), is outputted from the inverter (310) to the load, said control unit (400) suppressing the current flowing to the capacitor (210).

(57) 要約: 電力変換装置 (1) は、商用電源 (110) から供給される第1の交流電力を整流する整流部 (130) と、整流部 (130) の出力端に接続されるコンデンサ (210) と、コンデンサ (210) の両端に接続され、整流部 (130) およびコンデンサ (210) から出力される電力を第2の交流電力に変換し、モータ (314) を有する負荷に出力するインバータ (310) と、整流部 (130) からコンデンサ (210) に流入する電力の脈動に応じた脈動を含む第2の交流電力をインバータ (310) から負荷に出力するようにインバータ (310) の動作を制御し、コンデンサ (210) に流れる電流を抑制する制御部 (400) と、を備える。

POWER CONVERSION APPARATUS, MOTOR DRIVE APPARATUS, AND REFRIGERATION CYCLE APPARATUS

Field

5 [0001] The present disclosure relates to a power conversion apparatus that converts alternating-current power into desired power and also relates to a motor drive apparatus and a refrigeration cycle apparatus.

0 Background

[0002] There is a conventional power conversion apparatus that converts alternating-current power supplied from an alternating-current power supply into desired alternating-current power and supplies the desired alternating-current
5 power to a load in an air conditioner or another apparatus. For example, in a technique disclosed in Patent Literature 1 for a power conversion apparatus as a control apparatus for an air conditioner, alternating-current power supplied from an alternating-current power supply is rectified by a diode stack
0 as a rectification unit and is further smoothed by a smoothing capacitor. The smoothed power is converted by an inverter composed of a plurality of switching elements into desired alternating-current power for output to a compressor motor as a load.

25

Citation List

Patent Literature

[0003] Patent Literature 1: Japanese Patent Application Laid-open No. H07-71805

30

Summary

[0004] However, a problem with the above-described conventional technique is that a large current flows into the

smoothing capacitor, thus accelerating aging degradation of the smoothing capacitor. To address this problem, increasing capacitance of the smoothing capacitor for restraining variation of ripple in a capacitor voltage or using a smoothing capacitor with a greater tolerance to ripple-induced degradation is a conceivable method but causes increased costs of capacitor parts and causes the apparatus to have an increased size.

[0005] The present disclosure has been made in view of the above, and an advantage of some embodiments of the present disclosure is a power conversion apparatus that enables its increase in size to be restrained while restraining degradation of a capacitor to be used for smoothing.

[0006] In one embodiment a power conversion apparatus according to the present disclosure includes: a rectification unit rectifying a first alternating-current power supplied from a commercial power supply; a capacitor connected to output terminals of the rectification unit; an inverter that is connected across the capacitor, converts power output from the rectification unit and the capacitor into a second alternating-current power, and outputs the second alternating-current power to a load including a motor; and a control unit performing operation control on the inverter to cause the second alternating-current power that includes a pulsation based on a pulsation of power that flows into the capacitor from the rectification unit to be output from the inverter to the load, to restrain a current that flows into the capacitor.

[0006A] Another embodiment provides a power conversion apparatus comprising: a rectification unit rectifying a first alternating-current power supplied from a commercial power supply; a capacitor connected to output terminals of the rectification unit; an inverter that is connected across the capacitor, converts power output from the rectification unit

and the capacitor into a second alternating-current power, and outputs the second alternating-current power to a load including a motor; and a control unit performing operation control only on the inverter to cause the second alternating-current power that includes a pulsation based on a pulsation of power that flows into the capacitor from the rectification unit to be output from the inverter to the load, to restrain a current that flows into the capacitor.

Advantageous Effects of Invention

[0007] The power conversion apparatus according to some embodiments of the present disclosure can produce effects of enabling its increase in size to be restrained and restraining degradation of the capacitor that is used for smoothing.

Brief Description of Drawings

[0008] FIG. 1 is a diagram illustrating an exemplary configuration of a power conversion apparatus according to a first embodiment.

FIG. 2 is a diagram illustrating examples of currents as well as an example of a capacitor voltage across a capacitor in a smoothing unit in a comparative example in which the current output from a rectification unit has been smoothed by the smoothing unit, causing the current that flows into an inverter to be constant.

FIG. 3 is a diagram illustrating examples of the currents as well as an example of the capacitor voltage across the capacitor in the smoothing unit when a control unit of the power conversion apparatus according to the first embodiment has reduced the current that flows into the smoothing unit through operation control of the inverter.

FIG. 4 is a flowchart illustrating the operation of the control unit of the power conversion apparatus according to

the first embodiment.

FIG. 5 is a diagram illustrating an example of a hardware configuration that implements the control unit of the power conversion apparatus according to the first embodiment.

5 FIG. 6 is a diagram illustrating an exemplary configuration of a refrigeration cycle apparatus according to a second embodiment.

Description of Embodiments

0 [0009] With reference to the drawings, a detailed description is hereinafter provided of a power conversion apparatus, a motor drive apparatus, and a refrigeration cycle apparatus according to embodiments of the present disclosure.

[0010] First Embodiment.

5 FIG. 1 is a diagram illustrating an exemplary configuration of a power conversion apparatus 1 according to a first embodiment. The power conversion apparatus 1 is connected to a commercial power supply 110 and a compressor 315. The power conversion apparatus 1 converts a first
0 alternating-current power at a power supply voltage V_s that is supplied from the commercial power supply 110 into a second alternating-current power having a desired amplitude and a desired phase and supplies the second alternating-current power to the compressor 315. The power conversion apparatus 1
25 includes a voltage and current detection unit 501, a reactor 120, a rectification unit 130, a voltage detection unit 502, a smoothing unit 200, an inverter 310, current detection units 313a and 313b, and a control unit 400. The power conversion apparatus 1 and a motor 314 included in the compressor 315
30 compose a motor drive apparatus 2.

[0011] The voltage and current detection unit 501 detects a voltage value and a current value of the first alternating-current power at the power supply voltage V_s that is supplied

from the commercial power supply 110 and outputs the detected voltage and current values to the control unit 400. The reactor 120 is connected between the voltage and current detection unit 501 and the rectification unit 130. The rectification unit 130 includes a bridge circuit composed of rectifier elements 131 to 134, and rectifies the first alternating-current power at the power supply voltage V_s that is supplied from the commercial power supply 110 and outputs the power rectified. The rectification unit 130 performs full-wave rectification. The voltage detection unit 502 detects a voltage value of the power rectified by the rectification unit 130 and outputs the detected voltage value to the control unit 400. The smoothing unit 200 is connected to output terminals of the rectification unit 130 via the voltage detection unit 502. The smoothing unit 200 includes a capacitor 210 as a smoothing element and smooths the power rectified by the rectification unit 130. Examples of the capacitor 210 include an electrolytic capacitor and a film capacitor, among others. The capacitor 210 has such capacitance as to smooth the power rectified by the rectification unit 130. The smoothing causes voltage across the capacitor 210 to not assume a full-wave rectified waveform of the commercial power supply 110, but a waveform that includes a direct-current component with voltage ripple based on a frequency of the commercial power supply 110 superimposed and does not pulsate significantly. A main frequency component of this voltage ripple is a component that is double the frequency of the power supply voltage V_s when the commercial power supply 110 is single-phase or six times the frequency of the power supply voltage V_s when the commercial power supply 110 is three-phase. If the power input from the commercial power supply 110 and the power that is output from the inverter 310 do not change, the amplitude of this voltage ripple is determined by the capacitance of the

capacitor 210. For example, the voltage ripple generated across the capacitor 210 pulsates in a range such that its maximum value is less than twice its minimum value.

[0012] The inverter 310 is connected across the smoothing unit 200, namely the capacitor 210. The inverter 310 includes switching elements 311a to 311f and freewheeling diodes 312a to 312f. The inverter 310 turns on and off the switching elements 311a to 311f under control of the control unit 400, converts power output from the rectification unit 130 and the smoothing unit 200 into the second alternating-current power that has the desired amplitude and the desired phase, and outputs the second alternating-current power to the compressor 315. Each of the current detection units 313a and 313b detects a value of one of three phase currents that are output from the inverter 310 and outputs the detected current value to the control unit 400. By obtaining the values of the two phase currents of the values of three phase currents that are output from the inverter 310, the control unit 400 is enabled to calculate a value of a remaining one of the three phase currents that are output from the inverter 310. The compressor 315 is a load including the motor 314 that drives a compression mechanism. The motor 314 rotates according to the amplitude and the phase of the second alternating-current power supplied from the inverter 310, effecting compression operation. If, for example, the compressor 315 is a hermetic compressor that is used in an air conditioner or another apparatus, load torque of the compressor 315 can often be considered a constant torque load.

[0013] The arrangement of the configurations that is illustrated in FIG. 1 is an example. The power conversion apparatus 1 is not limited to the example arrangement of the configurations that is illustrated in FIG. 1. For example, the reactor 120 may be downstream of the rectification unit 130.

In a description below, the voltage and current detection unit 501, the voltage detection unit 502, and the current detection units 313a and 313b may all be referred to as the detection units. The voltage and current values detected by the voltage and current detection unit 501, the voltage value detected by the voltage detection unit 502, and the current values detected by the current detection units 313a and 313b may be referred to as the detection values.

[0014] The control unit 400 obtains the voltage and current values of the first alternating-current power at the power supply voltage V_s from the voltage and current detection unit 501, the voltage value of the power rectified by the rectification unit 130 from the voltage detection unit 502, and the current values of the second alternating-current power with the desired amplitude and the desired phase that has been obtained as a result of the conversion by the inverter 310 from the current detection units 313a and 313b. The control unit 400 uses the detection values detected by the detection units in controlling the operation of the inverter 310 or, more specifically, the on and off switching of the switching elements 311a to 311f of the inverter 310. The control unit 400 according to the present embodiment performs the operation control on the inverter 310 to cause the second alternating-current power that includes a pulsation based on a pulsation of the power that flows into the capacitor 210 of the smoothing unit 200 from the rectification unit 130 to be output from the inverter 310 to the compressor 315, which is the load. The pulsation based on the pulsation of the power that flows into the capacitor 210 of the smoothing unit 200 refers to, for example, a pulsation that changes depending on, for example, a frequency of the pulsation of the power that flows into the capacitor 210 of the smoothing unit 200. In this way, the control unit 400 restrains a current that flows

into the capacitor 210 of the smoothing unit 200. The control unit 400 does not have to use all the detection values obtained from the detection units. The control unit 400 may use part of the detection values in the control.

5 [0015] A description is provided next of how the control unit 400 of the power conversion apparatus 1 operates. In the power conversion apparatus 1 according to the present embodiment, a load that is generated by the inverter 310 and the compressor 315 can be regarded as the constant load. A
0 description below is based on the assumption that a constant current load is connected to the smoothing unit 200 when viewed in terms of a current that is output from the smoothing unit 200. Herein, as illustrated in FIG. 1, a current that flows from the rectification unit 130 refers to the current
5 I1, a current that flows into the inverter 310 refers to the current I2, and the current that flows from the smoothing unit 200 refers to the current I3. The current I2 is the current as a combination of the current I1 and the current I3. The current I3 can be expressed as a difference between the
0 current I2 and the current I1, that is to say, the current I2 minus the current I1. The current I3 has a positive direction in a discharge direction of the smoothing unit 200 and a negative direction in a charge direction of the smoothing unit 200. In other words, there are cases where the current flows
25 into and flows out of the smoothing unit 200.

[0016] FIG. 2 is a diagram illustrating examples of the currents I1 to I3 and an example of a capacitor voltage Vdc across the capacitor 210 in the smoothing unit 200 in a comparative example in which the current output from the
30 rectification unit 130 has been smoothed by the smoothing unit 200, causing the current I2 that flows into the inverter 310 to be constant. The current I1, the current I2, the current I3, and the capacitor voltage Vdc that is generated across the

capacitor 210 in accordance with the current I3 are illustrated from the top in this order. A vertical axis for each of the currents I1, I2, and I3 represents a current value, and a vertical axis for the capacitor voltage Vdc represents a voltage value. Every horizontal axis represents time t. Although a carrier component of the inverter 310 is actually superimposed on the currents I2 and I3, this is omitted here. The same applies to what follows. As illustrated in FIG. 2, if the current I1 that flows from the rectification unit 130 has been smoothed enough by the smoothing unit 200 in the power conversion apparatus 1, the current I2 that flows into the inverter 310 becomes a constant current value. However, the current I3 that flows into the capacitor 210 of the smoothing unit 200 is large and causes degradation of the capacitor 210. Therefore, the control unit 400 of the power conversion apparatus 1 according to the present embodiment controls the current I2 that flows into the inverter 310, that is to say, controls the operation of the inverter 310 in order to reduce the current I3 that flows into the smoothing unit 200.

[0017] FIG. 3 is a diagram illustrating examples of the currents I1 to I3 and an example of the capacitor voltage Vdc across the capacitor 210 in the smoothing unit 200 when the control unit 400 of the power conversion apparatus 1 according to the first embodiment has reduced the current I3 that flows into the smoothing unit 200 through the operation control of the inverter 310. The current I1, the current I2, the current I3, and the capacitor voltage Vdc that is generated across the capacitor 210 in accordance with the current I3 are illustrated from the top in this order. A vertical axis for each of the currents I1, I2, and I3 represents the current value, and a vertical axis for the capacitor voltage Vdc represents the voltage value. Every horizontal axis represents

time t . Through the operation control of the inverter 310 to cause the current I_2 , such as illustrated in FIG. 3, to flow into the inverter 310, the control unit 400 of the power conversion apparatus 1 is capable of reducing frequency components in the current that flows into the smoothing unit 200 from the rectification unit 130, thus reducing the current I_3 that flows into the smoothing unit 200, as compared with the example of FIG. 2. Specifically, the control unit 400 performs the operation control on the inverter 310 to cause the current I_2 that includes a pulsating current whose main component is a frequency component of the current I_1 to flow into the inverter 310.

[0018] The frequency component of the current I_1 is determined by a frequency of an alternating current supplied from the commercial power supply 110 and the configuration of the rectification unit 130. Therefore, the control unit 400 enables a frequency component of the pulsating current that is superimposed on the current I_2 to be a component having a predetermined amplitude and a predetermined phase. The frequency component of the pulsating current that is superimposed on the current I_2 has a waveform similar to that of the frequency component of the current I_1 . As the control unit 400 brings the frequency component of the pulsating current that is superimposed on the current I_2 closer to the frequency component of the current I_1 , the control unit 400 enables the current I_3 that flows into the smoothing unit 200 to reduce and enables a pulsating voltage that is generated in the capacitor voltage V_{dc} to reduce.

[0019] The pulsation control of the current that flows into the inverter 310 by the control unit 400 through the operation control of the inverter 310 is equivalent to pulsation control of the second alternating-current power that is output from the inverter 310 to the compressor 315. Through the operation

control of the inverter 310, the control unit 400 causes the pulsation included in the second alternating-current power that is output from the inverter 310 to become smaller than the pulsation of the power that is output from the rectification unit 130. In order for the voltage ripple of the capacitor voltage V_{dc} , namely the voltage ripple generated across the capacitor 210 to be smaller than voltage ripple that will be generated across the capacitor 210 if the second alternating-current power that is output from the inverter 310 does not include the pulsation based on the pulsation of the power that flows into the capacitor 210, the control unit 400 performs amplitude and phase control on the pulsation included in the second alternating-current power that is output from the inverter 310. Alternatively, in order for current ripple that flows into and out of the capacitor 210 to be smaller than current ripple that will be generated through the capacitor 210 if the second alternating-current power that is output from the inverter 310 does not include the pulsation based on the pulsation of the power that flows into the capacitor 210, the control unit 400 performs the amplitude and phase control on the pulsation included in the second alternating-current power that is output from the inverter 310. The case where the second alternating-current power that is output from the inverter 310 does not include the pulsation based on the pulsation of the power that flows into the capacitor 210 refers to control, such as illustrated in FIG. 2.

[0020] The alternating current that is supplied from the commercial power supply 110 is not particularly limited and may be single-phase or three-phase. The control unit 400 only has to determine the frequency component of the pulsating current that is superimposed on the current I_2 on the basis of the first alternating-current power that is supplied from the

commercial power supply 110. Specifically, the control unit 400 controls a pulsating waveform of the current I2 that flows into the inverter 310 to a shape obtained by adding a direct-current component to a pulsating waveform whose main component is a frequency component that is double a frequency of the first alternating-current power if the first alternating-current power that is supplied from the commercial power supply 110 is single-phase or six times the frequency of the first alternating-current power if the first alternating-current power that is supplied from the commercial power supply 110 is three-phase. The pulsating waveform is, for example, a shape defined by absolute values of a sine wave or sine wave-shaped. In this case, the control unit 400 may add at least one of frequency components that are integer multiples of a frequency of the sine wave as a prespecified amplitude to the pulsating waveform. The pulsating waveform may be rectangular wave-shaped or triangular-wave shaped. In this case, the control unit 400 may set amplitude and phase of the pulsating waveform as prespecified values.

[0021] The control unit 400 may use the voltage across the capacitor 210 or the current flowing into the capacitor 210 in calculating a pulsating quantity of the pulsation to be included in the second alternating-current power, which is output from the inverter 310, or may use the voltage or the current of the first alternating-current power supplied from the commercial power supply 110 in calculating a pulsating quantity of the pulsation to be included in the second alternating-current power, which is output from the inverter 310.

[0022] With reference to a flowchart, a description is provided of the operation of the control unit 400. FIG. 4 is a flowchart illustrating the operation of the control unit 400 of the power conversion apparatus 1 according to the first

embodiment. The control unit 400 obtains detection values from the detection units of the power conversion apparatus 1 (step S1). On the basis of the obtained detection values, the control unit 400 performs, on the inverter 310, the operation control to reduce the current I3 that flows into the smoothing unit 200 (step S2).

[0023] A description is provided next of a hardware configuration of the control unit 400 of the power conversion apparatus 1. FIG. 5 is a diagram illustrating an example of the hardware configuration that implements the control unit 400 of the power conversion apparatus 1 according to the first embodiment. The control unit 400 is implemented with a processor 91 and a memory 92.

[0024] The processor 91 is a central processing unit (CPU) (also referred to as a processing unit, an arithmetic unit, a microprocessor, a microcomputer, a processor, or a digital signal processor (DSP)) or a system large-scale integration (LSI). The memory 92 is, for example, a nonvolatile or volatile semiconductor memory such as a random-access memory (RAM), a read-only memory (ROM), a flash memory, an erasable programmable read-only memory (EPROM), or an electrically erasable programmable read-only memory (EEPROM) (registered trademark). The memory 92 is not limited to these and may be a magnetic disk, an optical disk, a compact disk, a mini disk, or a digital versatile disc (DVD).

[0025] As described above, according to the present embodiment, the control unit 400 of the power conversion apparatus 1 performs the operation control on the inverter 310 on the basis of the detection values obtained from the detection units to superimpose the pulsating frequency component based on the frequency component of the current I1 flowing from the rectification unit 130 on the current I2 that flows into the inverter 310, thus reducing the current I3 that

flows into the smoothing unit 200. Since the current I3 that flows into the smoothing unit 200 is reduced thus, the power conversion apparatus 1 is enabled to use a capacitor with a smaller tolerance to ripple current than in a case where the control according to the present embodiment is not performed. Since the power conversion apparatus 1 reduces the pulsating voltage in the capacitor voltage Vdc, the capacitor 210 to be installed is enabled to have a smaller capacitance than in the case where the control according to the present embodiment is not performed. In cases where, for example, the smoothing unit 200 includes a plurality of the capacitors 210, the power conversion apparatus 1 enables the smoothing unit 200 to have a reduced number of capacitors 210.

[0026] Since the pulsation included in the second alternating-current power is caused, through the operation control of the inverter 310, to become smaller than the pulsation of the power that is output from the rectification unit 130, the power conversion apparatus 1 enables the pulsating component superimposed on the current I2 that flows into the inverter 310 to be restrained from becoming excessive. Superimposing the pulsating component increases an effective value of the current that passes through, for example, the inverter 310 and the motor 314 compared to a state in which the pulsating component is not superimposed. However, the pulsating component to be superimposed is restrained from becoming excessive, thus enabling provision of a system that restrains current capacity of the inverter 310, loss increase in the inverter 310 and loss increase in the motor 314, among others.

[0027] With the control according to the present embodiment, the power conversion apparatus 1 is capable of restraining vibration of the compressor 315 that is caused by the pulsation of the current I2.

[0028] Second Embodiment.

FIG. 6 is a diagram illustrating an exemplary configuration of a refrigeration cycle apparatus 900 according to a second embodiment. The refrigeration cycle apparatus 900 according to the second embodiment includes the power conversion apparatus 1 described in the first embodiment. The refrigeration cycle apparatus 900 according to the second embodiment is applicable to a product with a refrigeration cycle, such as an air conditioner, a refrigerator, a freezer, or a heat pump water heater. In FIG. 6, constituent elements with the same functions as those in the first embodiment have the same reference characters as in the first embodiment.

[0029] The refrigeration cycle apparatus 900 has the compressor 315 with the internal motor 314 in the first embodiment, a four-way valve 902, an indoor heat exchanger 906, an expansion valve 908, and an outdoor heat exchanger 910 connected via refrigerant piping 912.

[0030] The compressor 315 internally includes a compression mechanism 904 that compresses a refrigerant and the motor 314 that runs the compression mechanism 904.

[0031] The refrigeration cycle apparatus 900 is capable of operating for heating or cooling through switching operation of the four-way valve 902. The compression mechanism 904 is driven by the motor 314 that is controlled at variable speed.

[0032] In the operation for heating, as indicated by solid line arrows, the refrigerant is pressurized and discharged by the compression mechanism 904 and returns to the compression mechanism 904 through the four-way valve 902, the indoor heat exchanger 906, the expansion valve 908, the outdoor heat exchanger 910, and the four-way valve 902.

[0033] In the operation for cooling, as indicated by dashed line arrows, the refrigerant is pressurized and discharged by the compression mechanism 904 and returns to the compression

mechanism 904 through the four-way valve 902, the outdoor heat exchanger 910, the expansion valve 908, the indoor heat exchanger 906, and the four-way valve 902.

[0034] In the operation for heating, the indoor heat exchanger 906 acts as a condenser to release heat, and the outdoor heat exchanger 910 acts as an evaporator to absorb heat. In the operation for cooling, the outdoor heat exchanger 910 acts as a condenser to release heat, and the indoor heat exchanger 906 acts as an evaporator to absorb heat. The expansion valves 908 depressurizes and expands the refrigerant.

[0035] The above configurations illustrated in the embodiments are illustrative, can be combined with other techniques that are publicly known, and can be partly omitted or changed without departing from the gist. The embodiments can be combined together.

[0036] In the claims which follow and in the preceding description of the invention, except where the context requires otherwise due to express language or necessary implication, the word "comprise" or variations such as "comprises" or "comprising" is used in an inclusive sense, i.e. to specify the presence of the stated features but not to preclude the presence or addition of further features in various embodiments of the invention.

[0037] It is to be understood that, if any prior art publication is referred to herein, such reference does not constitute an admission that the publication forms a part of the common general knowledge in the art, in Australia or any other country.

Reference Signs List

[0038] 1 power conversion apparatus; 2 motor drive apparatus; 110 commercial power supply; 120 reactor; 130 rectification unit; 131 to 134 rectifier element; 200 smoothing unit; 210 capacitor; 310 inverter; 311a to 311f switching element; 312a to 312f freewheeling diode; 313a, 313b current detection unit; 314 motor; 315 compressor; 400 control unit; 501 voltage and current detection unit; 502 voltage detection unit; 900 refrigeration cycle apparatus; 902 four-way valve; 904 compression mechanism; 906 indoor heat exchanger; 908 expansion valve; 910 outdoor heat exchanger; 912 refrigerant piping.

CLAIMS

1. A power conversion apparatus comprising:
 - a rectification unit rectifying a first alternating-current power supplied from a commercial power supply;
 - a capacitor connected to output terminals of the rectification unit;
 - an inverter that is connected across the capacitor, converts power output from the rectification unit and the capacitor into a second alternating-current power, and outputs the second alternating-current power to a load including a motor; and
 - a control unit performing operation control only on the inverter to cause the second alternating-current power that includes a pulsation based on a pulsation of power that flows into the capacitor from the rectification unit to be output from the inverter to the load, to restrain a current that flows into the capacitor.
2. The power conversion apparatus according to claim 1, wherein
 - the control unit performs operation control on the inverter to cause a pulsation included in the second alternating-current power that is output from the inverter to become smaller than a pulsation of power that is output from the rectification unit.
3. The power conversion apparatus according to claim 1 or 2, wherein
 - the control unit performs amplitude and phase control on a pulsation included in the second alternating-current power that is output from the inverter to cause voltage ripple generated across the capacitor to be smaller than voltage

ripple that is generated across the capacitor if the second alternating-current power that is output from the inverter does not include a pulsation based on a pulsation of power that flows into the capacitor.

4. The power conversion apparatus according to claim 1 or 2, wherein

the control unit performs amplitude and phase control on a pulsation included in the second alternating-current power that is output from the inverter to cause current ripple that flows into and out of the capacitor to be smaller than current ripple that is generated through the capacitor if the second alternating-current power that is output from the inverter does not include a pulsation based on a pulsation of power that flows into the capacitor.

5. The power conversion apparatus according to any one of claims 1 to 4, wherein

the control unit controls a pulsating waveform of a current that flows into the inverter to a shape obtained by adding a direct-current component to a pulsating waveform including as a main component a frequency component that is double a frequency of the first alternating-current power if the first alternating-current power is single-phase or six times a frequency of the first alternating-current power if the first alternating-current power is three-phase.

6. The power conversion apparatus according to claim 5, wherein

the pulsating waveform is a shape defined by absolute values of a sine wave or sine-wave shaped.

7. The power conversion apparatus according to claim 6,

wherein

the control unit adds at least one of frequency components that are integer multiples of a frequency of the sine wave as a specified amplitude to the pulsating waveform.

8. The power conversion apparatus according to claim 5, wherein

the pulsating waveform is rectangular wave-shaped or triangular-wave shaped.

9. The power conversion apparatus according to claim 8, wherein

the control unit sets an amplitude and a phase of the pulsating waveform as specified values.

10. The power conversion apparatus according to any one of claims 1 to 9, wherein

the control unit uses a voltage across the capacitor or a current that flows into the capacitor in calculating a pulsating quantity of a pulsation to be included in the second alternating-current power that is output from the inverter.

11. The power conversion apparatus according to any one of claims 1 to 9, wherein

the control unit uses a voltage or a current of the first alternating-current power in calculating a pulsating quantity of a pulsation to be included in the second alternating-current power that is output from the inverter.

12. The power conversion apparatus according to any one of claims 1 to 11, wherein

the capacitor is an electrolytic capacitor or a film capacitor.

13. The power conversion apparatus according to any one of claims 1 to 12, wherein

voltage ripple generated across the capacitor has a maximum value less than twice a minimum value of the voltage ripple.

14. The power conversion apparatus according to any one of claims 1 to 13, wherein

the rectification unit performs full-wave rectification, and a voltage generated across the capacitor assumes a shape that is not a full-wave rectified waveform of the commercial power supply.

15. A motor drive apparatus comprising the power conversion apparatus according to any one of claims 1 to 14.

16. A refrigeration cycle apparatus comprising the power conversion apparatus according to any one of claims 1 to 14.

FIG.1

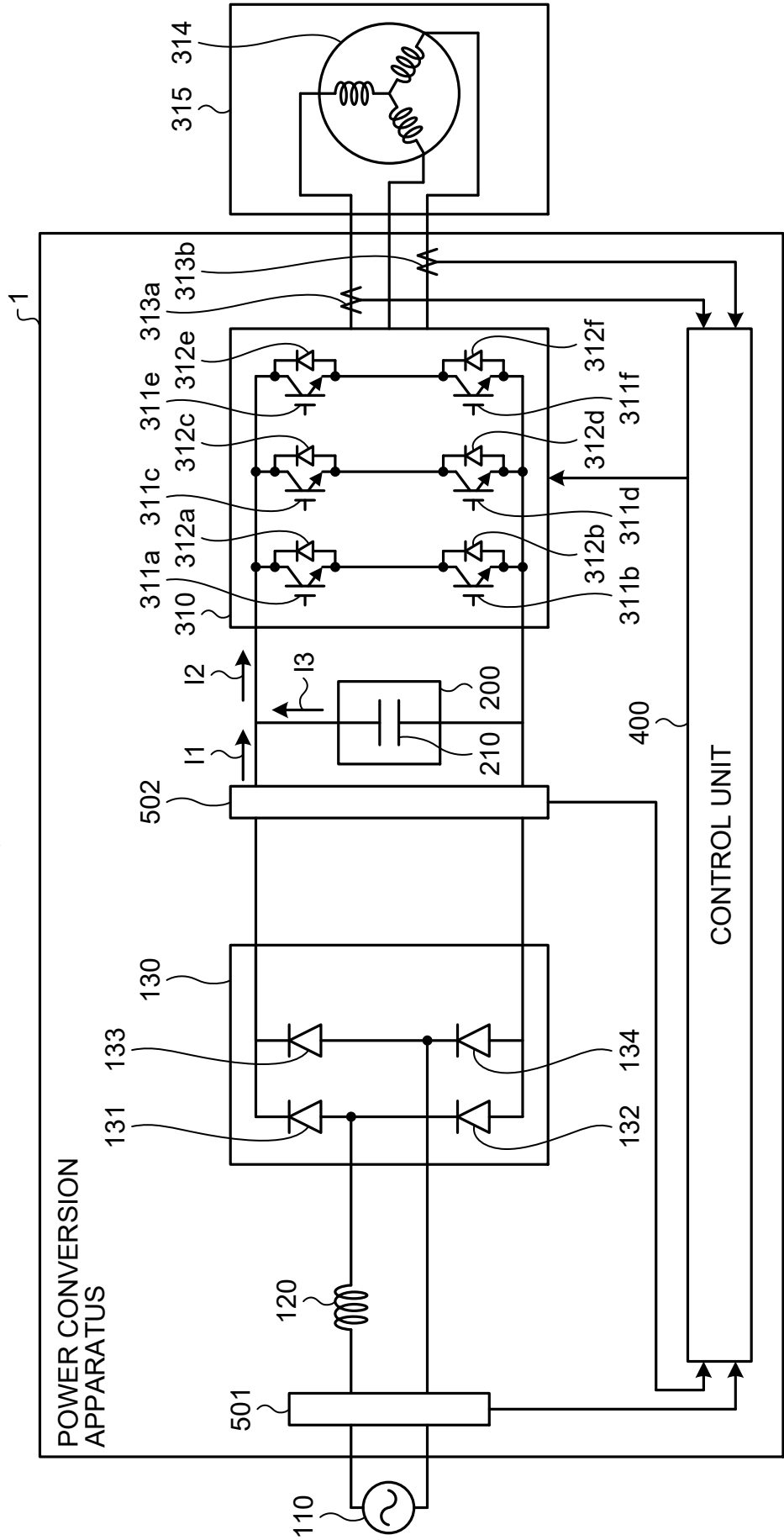

FIG.2

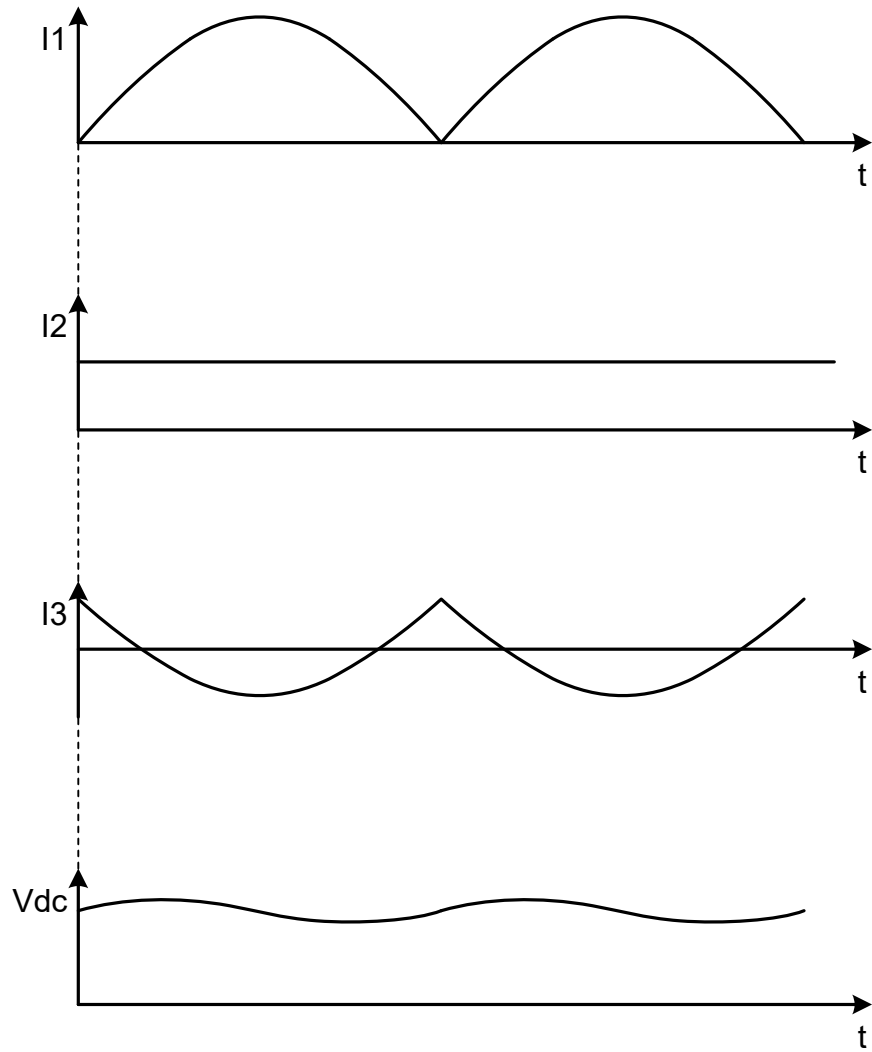

FIG.3

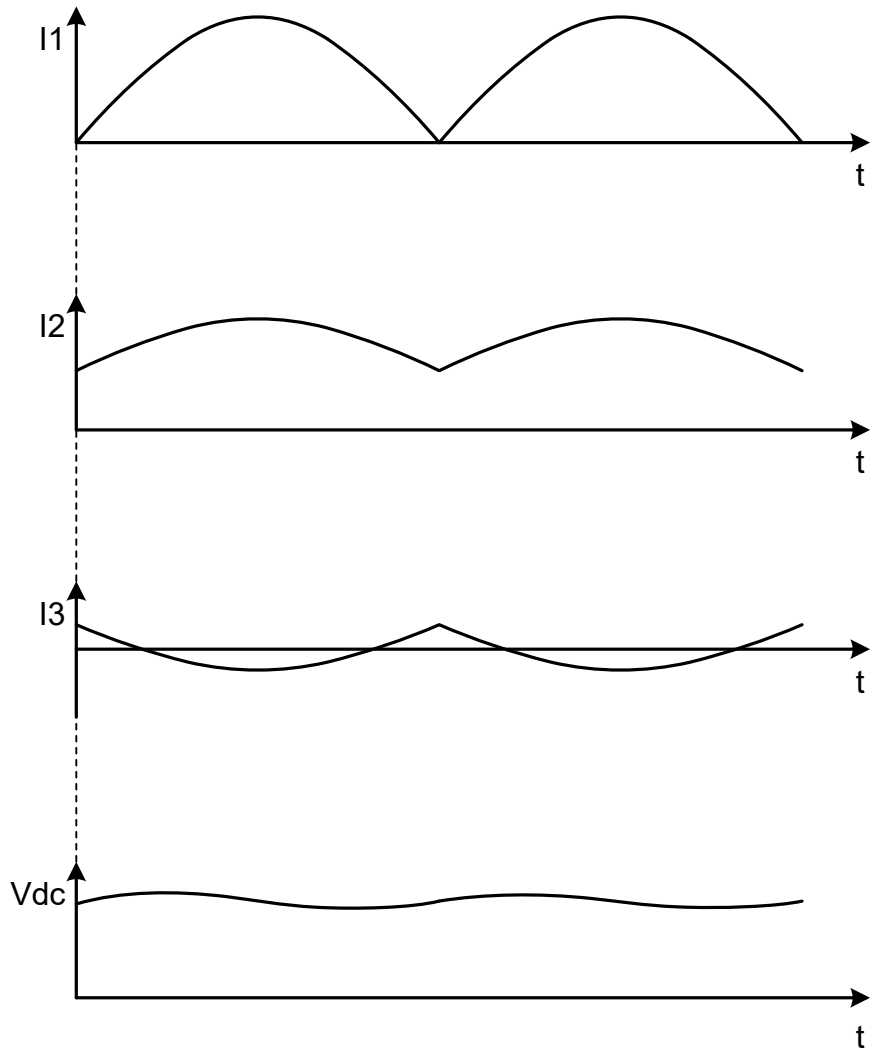

FIG.4

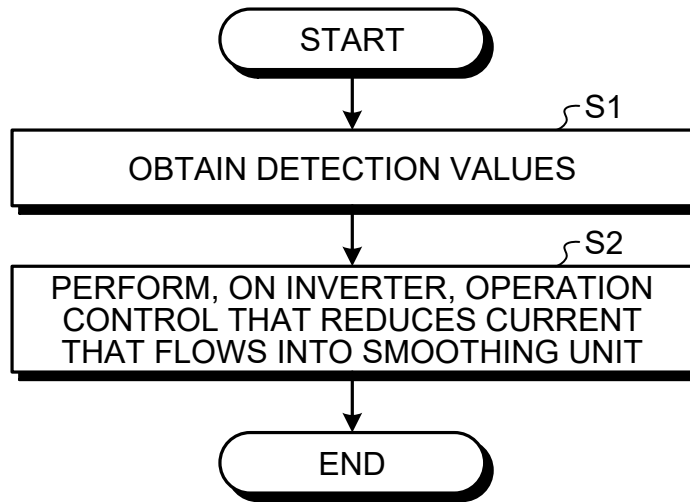

FIG.5

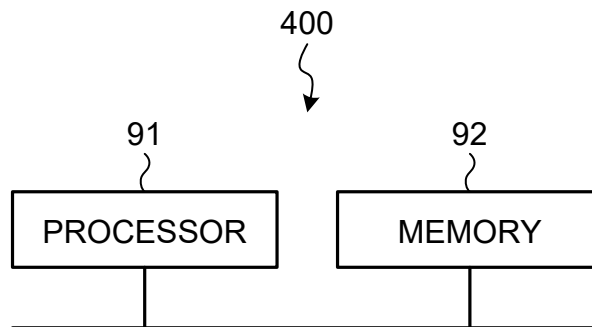

FIG.6

