

(No Model.)

5 Sheets—Sheet 1.

E. M. BUTZ.

ART OF MANUFACTURING STRUCTURAL MATERIAL.

No. 526,804.

Patented Oct. 2, 1894.

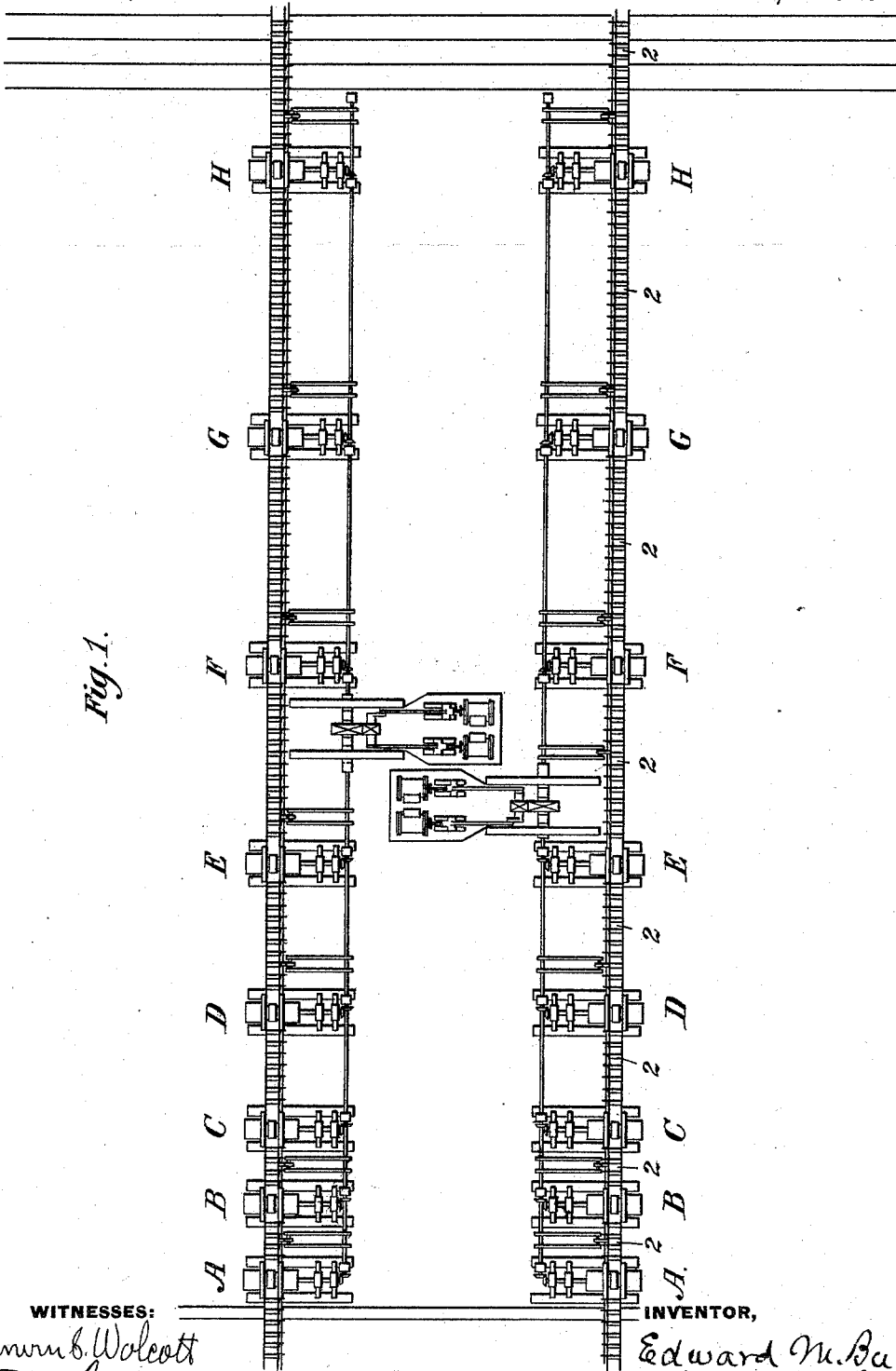

Fig. 1.

WITNESSES:

Danvers B. Wolcott
J. C. Gaikler

INVENTOR,

Edward M. Butz
 by *George N. Christy*
 Att'y.



(No Model.)

5 Sheets—Sheet 2.

E. M. BUTZ.

ART OF MANUFACTURING STRUCTURAL MATERIAL.

No. 526,804.

Patented Oct. 2, 1894.

FIG. 2.

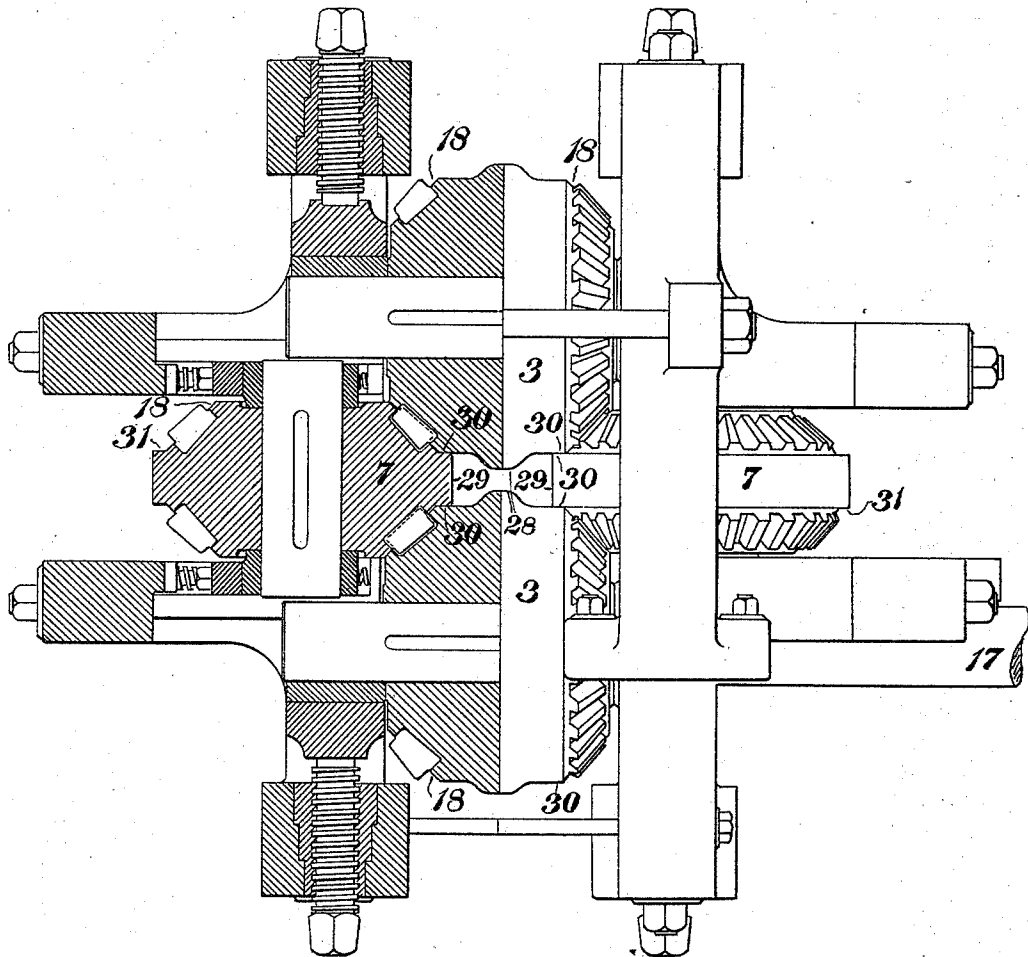

WITNESSES:

Danvy S. Wolcott
J. C. Saitter

INVENTOR,

Edward M. Butz,
by George H. Christy
Att'y.

E. M. BUTZ.

ART OF MANUFACTURING STRUCTURAL MATERIAL.

No. 526,804.

Patented Oct. 2, 1894.

FIG. 4.

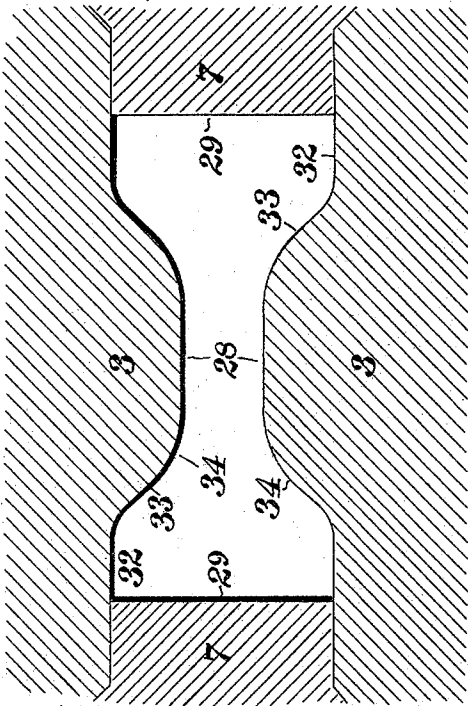

FIG. 6.

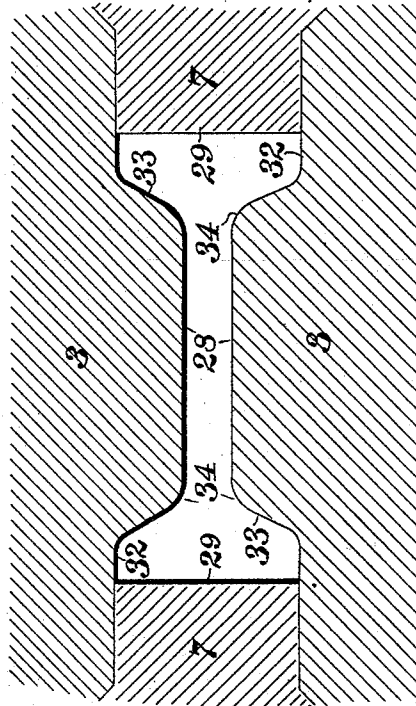

FIG. 3.

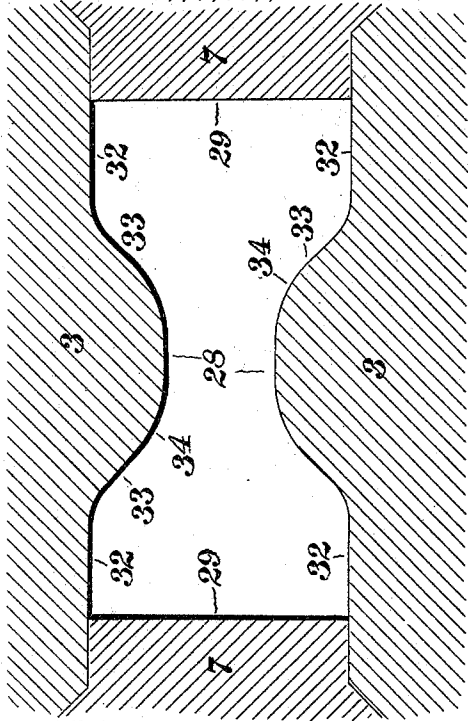
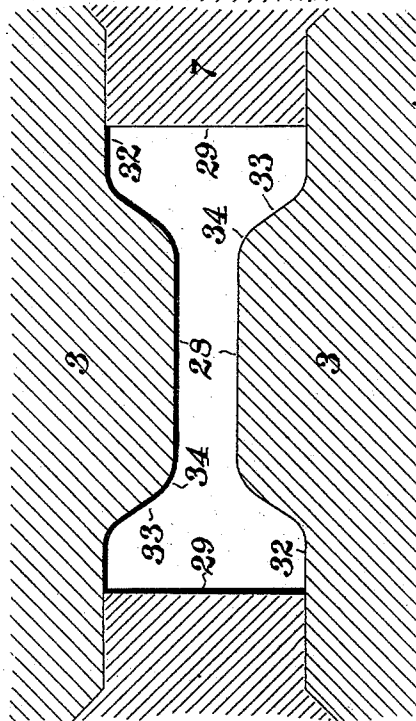

FIG. 5.



WITNESSES:

Dennis S. Wolcott
F. E. Gaither

INVENTOR,

Edward M. Butz,
by George H. Christy
Att'y.

E. M. BUTZ.

ART OF MANUFACTURING STRUCTURAL MATERIAL.

No. 526,804.

Patented Oct. 2, 1894.

FIG. 8.

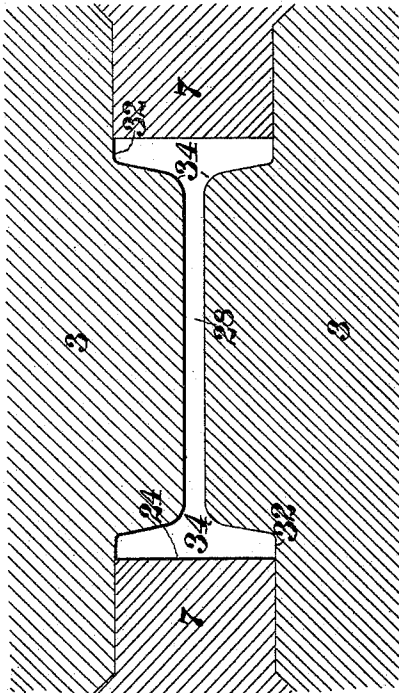

FIG. 10.

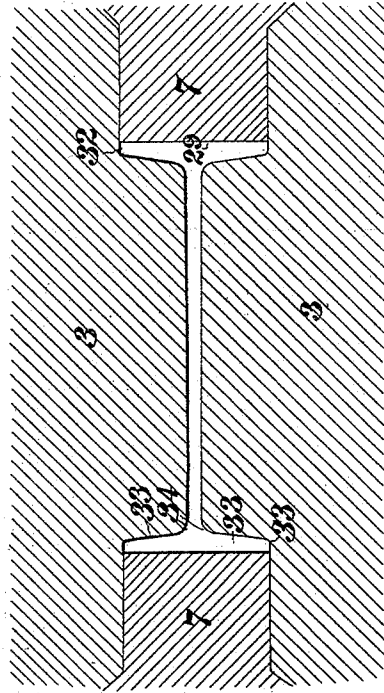

FIG. 7.

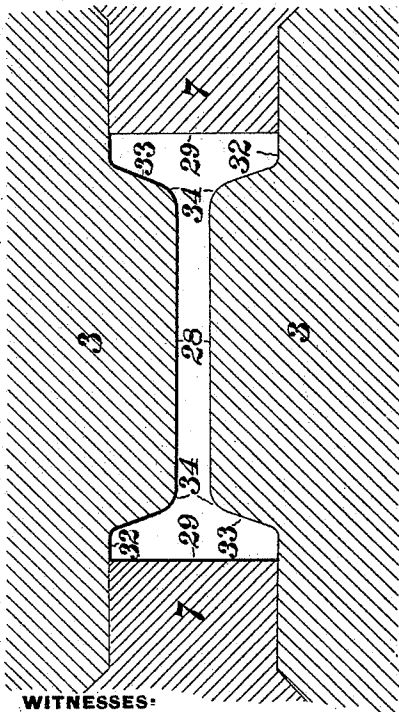
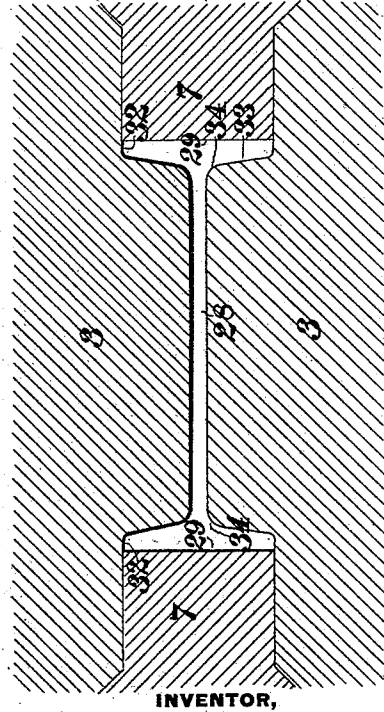

FIG. 9.



WITNESSES:

Danvers B. Wolcott
F. C. Gaither.

INVENTOR,

Edward M. Butz,
by George H. Christy
Att'y

(No Model.)

5 Sheets—Sheet 5.

E. M. BUTZ.

ART OF MANUFACTURING STRUCTURAL MATERIAL.

No. 526,804.

Patented Oct. 2, 1894.

FIG. 11.

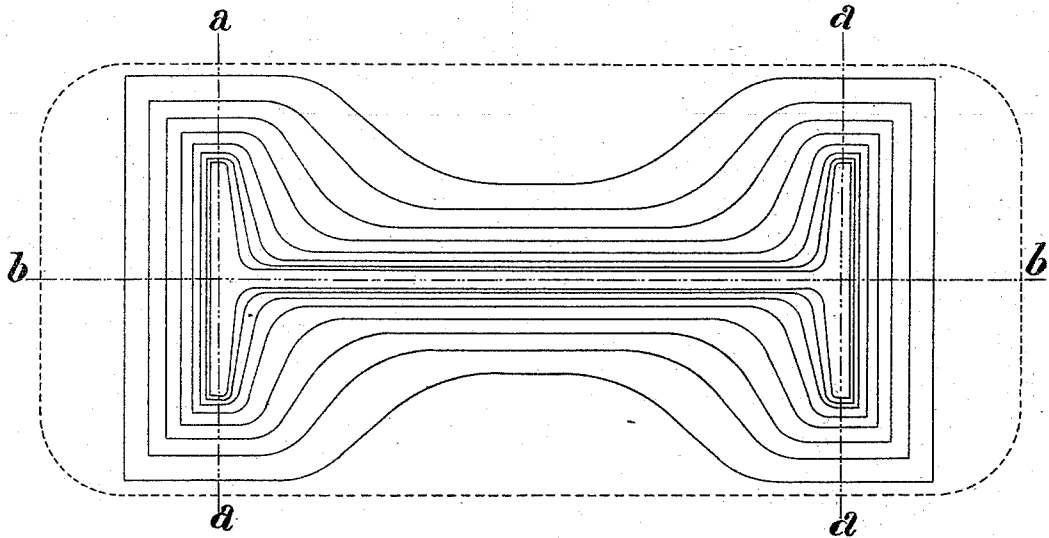
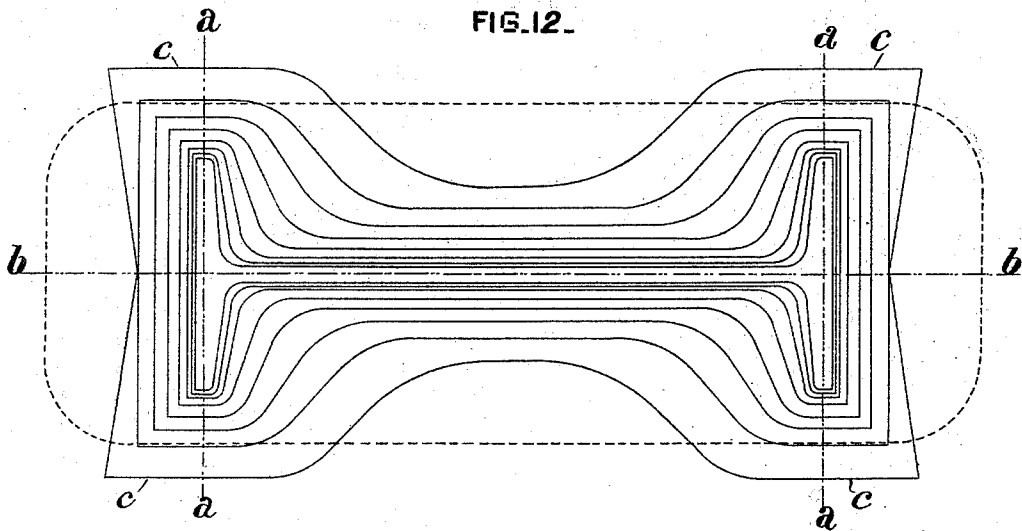

FIG. 12.



WITNESSES:

Danville S. Wolcott
J. E. Grother.

INVENTOR,

Edward M. Butz
by *George H. Christy*
Att'y.

UNITED STATES PATENT OFFICE.

EDWARD M. BUTZ, OF ALLEGHENY, PENNSYLVANIA, ASSIGNOR TO MARY H. BUTZ, OF SAME PLACE.

ART OF MANUFACTURING STRUCTURAL MATERIAL.

SPECIFICATION forming part of Letters Patent No. 526,804, dated October 2, 1894.

Original application filed January 3, 1893, Serial No. 457,014. Divided and this application filed April 24, 1893. Serial No. 471,603. (No specimens.)

To all whom it may concern:

Be it known that I, EDWARD M. BUTZ, a citizen of the United States, residing at Allegheny, in the county of Allegheny and State of Pennsylvania, have invented or discovered certain new and useful Improvements in the Art of Manufacturing Structural Material, of which improvements the following is a specification.

10 The invention described herein relates to certain improvements in the method of rolling structural shapes, such as I-beams, H-beams, &c., and has for its object the subjecting of the ingot, bloom or slab, on all sides and at each and every pass, to a positive rolling compression, whereby the stretching of any portion of the article is avoided, and it is a further object of this invention to provide for the lateral displacement of the metal toward the flange portions by a rolling wedge-like action, rather than by a squeezing action.

20 The art as at present practiced, may be divided into two methods, *i. e.*, the open pass and the semi-closed pass methods. In the former the ingot, bloom or slab is subjected to about six passes between grooved horizontal rolls, whereby what is termed the "sides" of the ingot, &c., are grooved, and the other two sides or "ends," as they are termed by mill men, and as they will be designated herein, are bulged out. The ingot, &c., is then given a quarter turn and subjected to about three passes, to not only reduce the bulge or protuberance along the "ends," but to dish or groove them somewhat. The ingot, &c., is then turned and the sides further grooved by about six passes, when the "ends" become so bulged as to require reduction. This alternate reduction on the "sides" and "ends" is continued for about twenty-seven or twenty-eight passes, by which time the ingot, bloom or slab has been reduced to a beam blank. This blank is then further reduced by three high roughing and finishing mills, having grooved horizontal rolls, to a finished beam. It is characteristic of these operations that as only the two sides or the two "ends" are acted on at the same time by the rolls,

the metal portions not acted on by the rolls at each pass must be subjected to a stretching or pulling action corresponding in extent to the elongation effected by the rolls, of the portions of the metal in contact therewith. This stretching is so severe as to frequently produce cracks, whereby the ingot, bloom or slab is unfit for reduction to beams, as cracks once formed in steel cannot be closed. It is also characteristic of this method of rolling that the metal of the flanges is subjected during the formation of the flanges to severe torsional strains, as the portions of the rolls operative in shaping the flanges have a movement at an angle to the line of movement of the ingot, bloom or slab through the rolls.

50
55
60
65
70
75
80
85
90
95
In the semi-closed pass method, the entire reduction from the ingot, bloom or slab to the finished beam is effected by the same set of rolls or by two or more sets of rolls exactly similar as regards the shape or contour of their operative faces. A proposed form of mill for the practice of this method is illustrated in Letters Patent No. 318,513. As the rolls of the mill shown in this patent are employed not only for the preliminary breaking down of the ingot, bloom or slab, but, also, for the final shaping of the beam, they must be shaped as regards their operative faces for the finishing operations. Hence, the portions of the horizontal rolls designed to displace the metal along the middle of the ingot, bloom or slab, and to shape the web of the beam, is made broad and flat, so that the metal of the ingot, bloom or slab along the middle thereof is squeezed out laterally as the horizontal rolls are adjusted toward each other. The metal so squeezed out along the "ends" of the ingot, bloom or slab, is upset by the action of the vertical rolls, thus causing it to expand into the grooves of the horizontal rolls for the formation of the flanges. In other words, the flanges are formed by two operations, first, the metal along the middle of the ingot, bloom or slab is squeezed out horizontally by the flat faces of the horizontal rolls, and then the metal so squeezed out is displaced vertically by contact with the vertical rolls.

As the vertical rolls are not positively driven, but the ingot, bloom or slab is drawn between them by the horizontal rolls, the metal squeezed out along the "ends" of the ingot, bloom or slab is subjected to a stretching action and that at a time when most liable to be injured by such action, and, further, it is a characteristic of the semi-closed pass method, that the edges of the flanges are not acted on by the rolls until the last or finishing pass, the flanges being formed gradually at each pass by the expansion of the metal above and below the planes of bite of the horizontal rolls, into grooves formed in said rolls.

The object of this invention is to provide for the lateral displacement by a wedge-like action of more or less of the metal which constitutes the middle portion of an ingot, bloom or slab, toward the "ends" or flange portions thereof, and simultaneously subjecting such "ends" or flange portions to a positive rolling compression, for the purpose of obtaining a uniform or approximately uniform working or reduction of all parts of the ingot, bloom or slab at each and every pass.

In the accompanying drawings forming a part of this specification, Figure 1 is a plan view of a mill applicable to the use and practice of my invention. Fig. 2 is a view, partly in section, and partly in elevation, of one of the stands or sets of rolls of the mill shown in Fig. 1. Figs. 3 to 10, inclusive, are sectional views illustrating the reduction effected by each stand or set of rolls of the mill, and Figs. 11 and 12, are diagrammatic views illustrating the various contours imparted to the ingot, bloom or slab during its reduction to a finished beam, Fig. 12 illustrating the reduction when portions of the ingot, bloom or slab are expanded during the first pass.

In the practice of my invention, I prefer to employ a mill substantially such as is described and shown in application, Serial No. 457,014, filed January 3, 1893. This mill, generally stated, consists of a series of stands or sets of rolls, A, B, C, D, E, F, G and H, preferably arranged in a common line of feed, with interposed feed tables 2, having positively driven rolls whereby the article is carried forward from one set of rolls to another. Each stand or set of rolls is adapted to effect one and only one reduction on each article, the movement of the article being constantly onward.

As described in said application, each stand or set of rolls consists of two horizontal rolls 3 and two vertical rolls 7, both pairs of rolls being positively driven. One of the horizontal rolls, preferably the lower one, is positively driven by the shaft 17, which is connected by a suitable coupling to the neck of said roll. The ends of the rolls, both horizontal and vertical, are beveled off at an angle of about forty-five degrees, so that a close fitting joint may be formed between the several

rolls and the beveled faces 18 of each of the rolls are provided with teeth, adapted to intermesh with the teeth on the ends of adjacent rolls, that is to say, the teeth on the ends of the lower horizontal roll intermesh with the teeth on the lower ends of the vertical rolls, while the teeth on the upper ends of the vertical rolls intermesh with the teeth on the ends of the upper horizontal roll. This manner of intergearing the several rolls insures the positive and equal rotation of all the rolls.

In order to prevent the formation of fins by the squeezing of the metal between the beveled faces of the rolls, the horizontal rolls are provided with extensions 30 between the operative faces and the beveled end faces. These extensions overlap corresponding shoulders 31 at the ends of the operative faces of the vertical rolls, as shown in Fig. 2. This construction places the beveled faces of the vertical and horizontal rolls a distance from the operative faces of said rolls equal to the lengths of the extensions and shoulders, which serve to force the metal of the article inwardly from the gaps between the beveled faces of the rolls.

The operative faces of the horizontal rolls are provided with ribs or collars 28, which project, when the horizontal and vertical rolls are arranged in operative relation to each other, between the operative faces 29 of the vertical rolls and serve to displace the metal along the middle of the ingot, bloom or slab laterally toward the "ends" or flange portions thereof, while the portions 32 of the operative faces of the horizontal rolls at the sides of the collars or ribs 28, operate on the upper and lower sides or edges of the flange portions compressing such portions vertically. The vertical rolls operate on the "ends" or flange portions of the ingot, bloom or slab and compress the ingot, bloom or slab laterally. As shown in Figs. 3 to 10 inclusive, this projection of portions of the horizontal rolls between the operative faces of the vertical rolls is characteristic of the rolls of each stand or set, as is also the positive compressive section of the portions 32 of the horizontal rolls in a vertical direction and that of the vertical rolls in a lateral direction.

It will be observed that the operative faces of both pairs of rolls gradually decrease in width and approach nearer to each other in each successive stand or set, thereby effecting a gradual step by step compression and reduction of all portions of the article toward the center lines *a, a*, and *b, b*, of the web and flanges of the article.

It will be observed that the side walls 33 of the ribs or collars 28 of the horizontal rolls change their angle with the axes of the rolls, in each and every stand or set. In the first stand or set these side walls 33 have a considerable outward curve or inclination, so

that the collars or ribs will have a wedge-like action in displacing or shoving the metal along the middle portions of the ingot, bloom or slab, laterally toward the "ends" or flange portions, as distinguished from a squeezing action between approximately flat surfaces, characteristic of the methods now practiced of displacing the metal from the middle portions of the ingot, bloom or slab. In other words, in my improved method, the metal is pushed directly out toward the "ends" or flange portions, in lieu of being forced in and then, as there is no other way of escape, flowing out laterally toward the "ends" or flange portions.

In the second stand or set, as shown in Fig. 4, the faces of the collars or ribs are somewhat wider and the side walls are more abrupt, so that there will be a greater lateral displacement of metal at and adjacent to the corners 34 of the collars or ribs than at other points of the walls and faces of the collars or ribs, as shown in Figs. 11 and 12. At each and every succeeding pass, the faces of the collars or ribs are widened and their side walls are made more abrupt as shown in Figs. 5 to 10, inclusive.

By reference to Figs. 11 and 12, it will be seen that by reason of the changing contour of the collars or ribs at each and every stand or set, the metal on the "sides" of the ingot, bloom or slab, is swept or pushed out horizontally, or approximately horizontally, in both directions from a central line, toward the "ends" or flange portions, rather than pushed in and then out toward the "ends" as in the old methods.

In the methods heretofore practiced, the flanges of the structural shapes are formed by causing the metal at the "ends" or flange portions of the ingot, bloom or slab to expand above and below the center line a, a , of the web, whereas it is characteristic of my improved method that the flanges are mainly formed by the inward compressive action of the vertical rolls on the "ends" or flange portions of the ingot, bloom or slab, and the combined vertical and lateral displacement of the metal of the "sides" of the ingot, bloom or slab, between the center lines b, b , of the flange.

It is a further distinctive characteristic of my invention, that there is a positive compressive reducing action by the portions 32 of the horizontal rolls on the edges of the flange portions at right angles to the compressive reducing action of the vertical rolls.

As will be seen by reference to Figs. 11 and 12, the rolls operate positively on each and every portion of the ingot, bloom or slab at each and every pass, and it will also be seen that except during the first pass, that an equal or approximately equal reduction of each and every portion is effected at each pass, so that there is an equal elongation of

each and every portion and not any stretching action of any portion, as will always result when only portions of an article are in contact with the reducing rolls.

In the reduction illustrated in Fig. 11, there is a positive compressive reduction on each and every part of the ingot, bloom or slab, at each pass, while in Fig. 12, the ingot, bloom or slab being somewhat narrower at its "ends" than the portions of the opening between the rolls, through which the "ends" pass, there will be a vertical expansion of the "ends" at the first pass, but this expansion is only necessary in order that the portions of the ingot c , may be acted on by the portions 32 of the horizontal rolls during the first pass, as well as at all succeeding passes.

It is further characteristic of my improved method that while the metal along the middle portions of the ingot, bloom or slab is displaced laterally by the projections on the horizontal rolls, the metal so displaced cannot flow into the flange portions, as such flange portions are also under positive compression. The metal thus displaced will also flow longitudinally of the ingot, bloom or slab effecting an elongation thereof.

It is also a characteristic of my improvement distinguishing from methods heretofore practiced in the manufacture of structural shapes, that the flanges are formed not by the lateral expansion of any portion but wholly by the displacement or removal of the metal along the middle portions of the ingot, bloom or slab, and that simultaneous with this displacement of the metal along the middle portions of the ingot, bloom or slab, the "ends" or flange are compressed and reduced in cross-sectional area.

I claim herein as my invention—

1. As an improvement in the art of manufacturing structural shapes, such as I-beams, &c., the method herein described which consists in laterally displacing, by a wedge-like action, during the process of rolling, more or less of the metal, which constitutes the middle portion of an ingot, bloom or slab, so as to push it over toward the "ends" or flange portions thereof and simultaneously and in the same rolling operation, subjecting such "ends" or flange portions to a rolling compression, with reference to a uniform or nearly uniform reduction of all portions of the ingot, bloom or slab while being brought to the finished form desired, substantially as set forth.

2. As an improvement in the art of manufacturing structural shapes, such as I-beams, &c., the method herein described, which consists in progressively and simultaneously compressing the metal of an ingot, bloom or slab at all points toward the center lines of the web and flanges by a rolling action at all points, with particular reference to the embodiment of the invention illustrated in Fig. 11, substantially as set forth.

3. As an improvement in the art of manufacturing structural material, the method herein described, which consists in forming the flanges by displacing the metal along the middle portions of the ingot, bloom or slab, and simultaneously compressing the "ends" or flange portions at all points whereby any upsetting of the metal is avoided, and the ingot, bloom or slab is shaped and reduced in cross-sectional dimensions at every point, substantially as set forth.

In testimony whereof I have hereunto set my hand.

EDWARD M. BUTZ.

Witnesses:

DARWIN S. WOLCOTT,
E. J. SMAIL.