

Sept. 29, 1953

S. C. MOON

2,653,807

KERF CUTTING MINING MACHINE, INCLUDING MECHANISM FOR REMOVING KERF CUTTINGS THEREFROM

Filed March 18, 1949

2 Sheets-Sheet 1

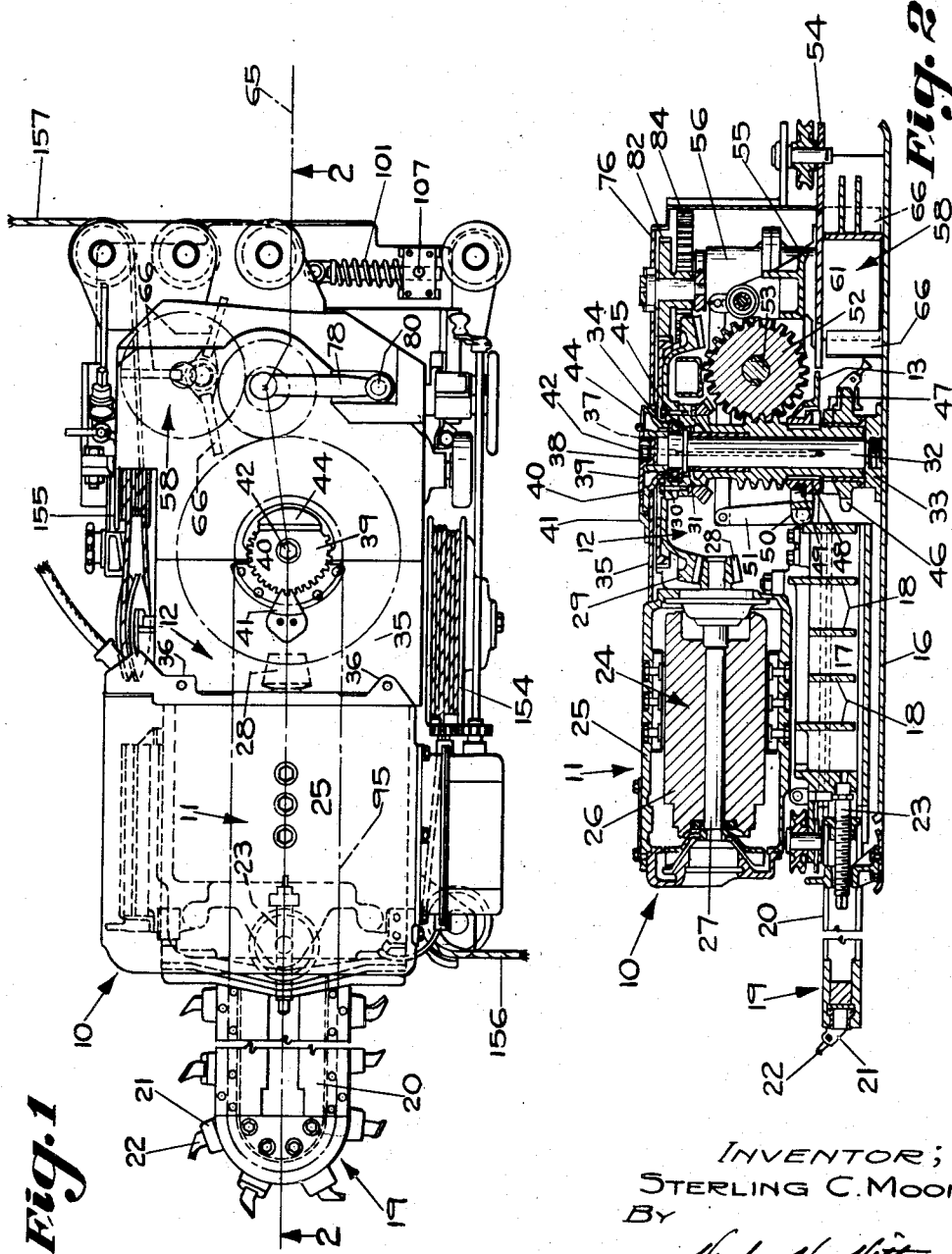

Fig. 1

Fig. 2

INVENTOR;
STERLING C. MOON,
BY

Stanley H. Hutton,
ATT'Y.

Sept. 29, 1953

S. C. MOON
KERF CUTTING MINING MACHINE, INCLUDING MECHANISM
FOR REMOVING KERF CUTTINGS THEREFROM

2,653,807

Filed March 18, 1949

2 Sheets-Sheet 2

Fig. 3

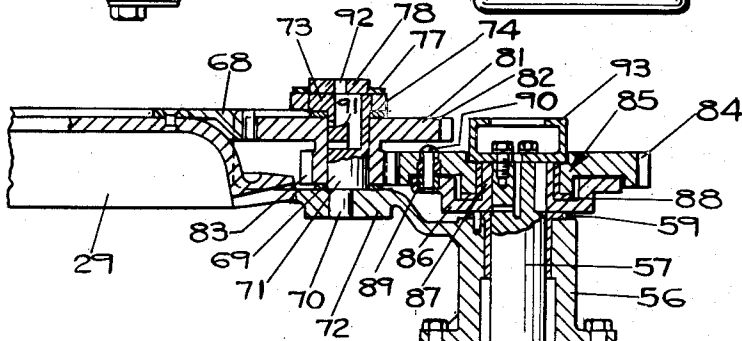
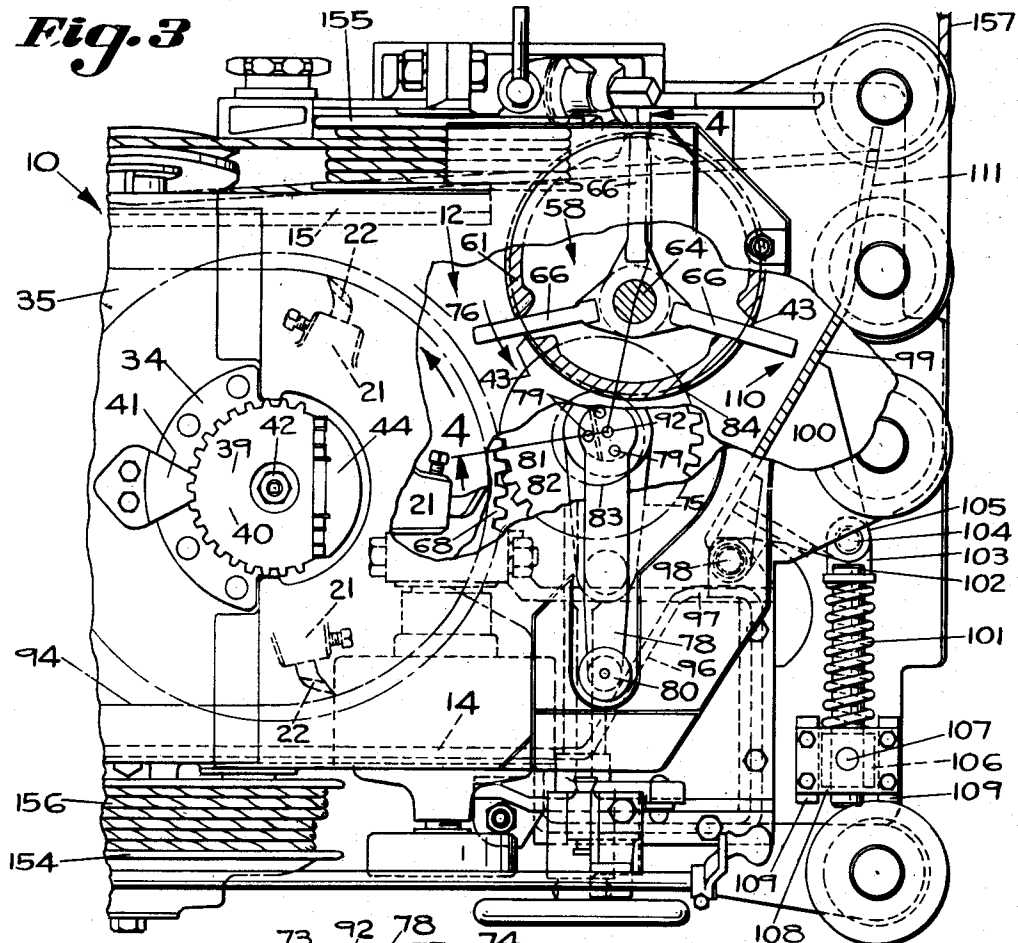
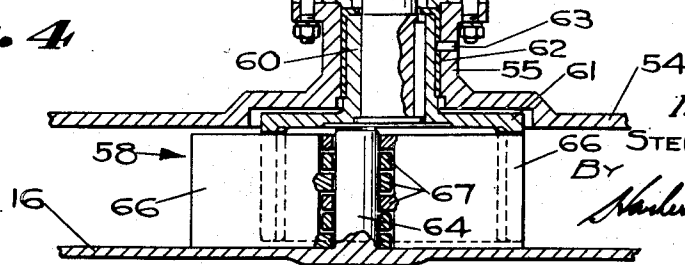

Fig. 4



INVENTOR;
S. C. MOON,
By *Harley H. Hutton,*
ATTY.

UNITED STATES PATENT OFFICE

2,653,807

KERF CUTTING MINING MACHINE, INCLUDING MECHANISM FOR REMOVING KERF CUTTINGS THEREFROM

Sterling C. Moon, Worthington, Ohio, assignor to The Jeffrey Manufacturing Company, a corporation of Ohio

Application March 18, 1949, Serial No. 82,108

2 Claims. (Cl. 262—30)

1

This invention relates to kerf cutting mining machines of the type which includes mechanism for discharging therefrom kerf cuttings which are carried from the kerf being cut into the machines by the kerf cutting apparatuses thereof.

It is one object of the invention to provide an improved mining machine of the above mentioned type.

Another object of the invention is to provide an improved kerf cutting mining machine of the above mentioned type which includes improved kerf cuttings removing apparatus.

Another object of the invention is to provide in a mining machine of the above mentioned type, or per se, an improved cuttings removing mechanism including a way through which the cuttings must pass and in which they are compressed or compacted, the way being resiliently expandible to pass large pieces of material contained in the cuttings.

Other objects of the invention will appear hereinafter the novel features and combinations being set forth in the appended claims.

In the accompanying drawings,

Fig. 1 is a view in plan of a shortwall mining machine including features of the invention;

Fig. 2 is a longitudinal view in section through the mining machine seen in Fig. 1, the view being taken substantially on line 2—2 of Fig. 1;

Fig. 3 is a view in plan with parts broken away and on a larger scale of the rear portion of the mining machine seen in Fig. 1; and

Fig. 4 is a view in section, the section being taken substantially on line 4—4 of Fig. 3.

The mining machine shown in the drawings, with the exception of certain structure shown and described herein in detail, is identical to the mining machine shown and described by Nils D. Levin in his Patent No. 1,371,314, dated March 15, 1921.

Referring first to Figs. 1 and 2 of the drawings the mining machine may be described briefly as being of the shortwall type and including a main frame 10 built up of members so as to include a forward motor section 11 and a rearward machinery section 12. Main frame 10 includes a base casting 13 which at each side is attached to upwardly extending flanges 14 and 15 (see Fig. 3) of a skid pan 16 (see Fig. 2). Skid pan 16 may be considered as the bottom member of the main frame 10 and it serves as a broad supporting base upon which the machine is adapted to slide in any direction over the floor of the mine.

Extending longitudinally of the base casting

2

13 are two spaced downwardly projecting ribs 17, one of which is seen in Fig. 2, which are joined at intervals by cross webs 18 to form a rigid support for a cutter bar 19 that extends forwardly from the main frame 10 adjacent and below the forward motor section 11. The outer faces of ribs 17 slidably engage the rearward part of the U-shaped frame 20. An endless kerf cutting chain 21 of the cutter bar 19 which is provided with removable bits 22 travels around the outer peripheral edge of the cutter bar frame 20. The cutter bar 19 may be adjusted with respect to the base casting 13 to adjust the tension of the endless kerf cutting chain 21 by means of an adjusting mechanism including a screw 23 which adjusting mechanism is fully described in the above identified patent to Nils D. Levin.

The mining machine is driven by an explosion-proof electric motor 24 the housing or frame 25 of which may be considered a part of the main frame 10 and within which there is an armature 26, the shaft 27 of which extends, projects or protrudes rearwardly from the motor housing and forward motor section of the mining machine into the rearward machinery section 12 thereof. The end of armature shaft 27 which extends into the rearward machinery section 12 carries a beveled pinion gear 28 which meshes with and drives a large bevel or master gear 29.

The master gear 29 is attached by machine screws 30 to the upper end of a sleeve or hollow drive shaft 31 which is journaled for rotation about a stationary upright shaft 32. The lower end of shaft 32 is screw threaded into a flange casting 33 riveted to the skid pan 16, and at its upper end is fastened in the central bore of a yoke casting 34. The yoke casting 34 is riveted to a cover plate 35 which is bolted to lugs 36 (Fig. 1) formed on the motor housing or frame, thereby affording a rigid support for the top of shaft 32 and the gearing mounted thereon. Shaft 32 is slotted across its top surface to receive a downwardly projecting key, lug or ear 37 on the bottom of a downwardly extending boss 38 of a locking plate 39 that extends into the central bore of the yoke casting 34. Locking plate 39 includes a flat top portion 40 (see Fig. 1) that is serrated around a portion of its outer edge and which serrated portion is adapted to interfit with the serration on a locking lug 41 riveted to the cover plate 35. The boss portion 38 of locking plate 39 is recessed and centrally bored to receive a hollow cap screw 42 that extends through the locking plate 39 and is threaded into the

shaft 32. Shaft 32 is provided with a bore that leads to a bearing surface thereof adjacent its bottom. Cap screw 42 is hollow to provide an oil or lubricant passage that connects with the bore in shaft 32 and through which lubricant may be fed to said bottom bearing surface. At one side the top portion 40 of locking plate 39 carries through a hinge a lid 44 that may be lifted whereby oil or lubricant may be placed in the cup-like top of yoke casting 34 from which the lubricant will flow to the bearings at the top of shaft 32 through passageways, seen in Fig. 2 of the drawings.

One of the main functions of the locking plate 39 is to lock the shaft 32 in position, that is, to prevent it from unscrewing from the flange casting 33 and to provide a locking means that will accommodate wear and slight inaccuracies in the machining of the parts to be locked together. For example, when shaft 32 is threaded into the flange casting 33 by a wrench which engages its upper slotted surface, the locking plate 39 by reason of its peripheral serrations may be applied to lock the shaft 32 in any of a plurality of different angular positions in which the slot in the top of shaft 32 may extend.

Shaft 32 includes a flange adjacent its upper end upon which there rests a ball bearing thrust collar 45 that supports the large bevel or master gear 29 as well as the hollow drive shaft sleeve 31 which is attached to the gear 29 and upward thrust of the drive shaft sleeve 31 and gear 29 is resisted by the thrust collar 45 bearing against the yoke casting 34.

Rotatably mounted upon the lower end of the drive shaft sleeve 31 is a sprocket wheel 46 over and around which the cutter chain 21 at the rear of the cutter bar frame 20 travels or circulates and by which the cutter chain 21 is driven. Upon the upper side of sprocket wheel 46 are formed clutch teeth 47 engageable with the teeth of a clutch member 48 splined to the drive shaft sleeve 31. Clutch member 48 is grooved to receive a shifting yoke 49 which is carried by a shifting lever 50 operated by a linkage mechanism indicated generally at 51 which may be manually operated to engage or disengage the clutch member 48 and the sprocket 46. Above and adjacent the clutch member 48 the drive shaft sleeve 31 forms a worm gear that meshes with and drives a worm wheel 52 carried upon a transverse shaft 53 mounted in motor section 12 which drives, through suitable gearing and clutches, winding drums 154 and 155 upon which ropes 156 and 157 are wound to move the machine about the mine, all as described in the above identified patent to Nils D. Levin.

In the mining machine of Nils D. Levin kerf cuttings removed from a kerf being cut are fed or dragged rearwardly by the cutter chain under the forward motor section 11 and rearward machinery section 12 between the bottom of the base casting 13, the skid pan 16, the outer surface of the cutter chain and an upwardly extending side flange of the skid pan and discharged at the rear of the mining machine. Because the quantity of kerf cuttings discharged at the rear of the cutter chain is relatively large there is a tendency for the cuttings to pile up and channel about the cutter chain where it travels around the drive sprocket and when this is permitted to occur the cutter chain cannot discharge the cuttings and quantities of them are carried back into the kerf by the cutter chain as it travels along the non-working or non-cutting side of the cutter

bar. This is detrimental in that it tends to fill the cut kerf with cuttings or bug dust which usually must be shoveled manually therefrom. By this invention the mining machine of Nils D. Levin is provided with a bug duster, gummer, or cuttings removing apparatus now to be described which positively removes from the rear of the mining machine the cuttings discharged by the kerf cutter chain as it travels around the drive sprocket 46 thus preventing cuttings from accumulating adjacent the cutter chain and sprocket.

Extending transversely below the rearward machinery section 12 of the mining machine and rearwardly of the base casting 13 is a frame plate 54 (see Figs. 2 and 4) that is carried at its ends by the upwardly extending side flanges 14 and 15 of the U-shaped skid pan 16. Frame plate 54 is spaced above the bottom of the skid pan 16 and includes as an integral part an upstanding tubular column 55 that is flanged at its top to receive a tubular support or bracket 56 which is bolted thereto. Within the tubular column 55 and the bracket 56 there is a shaft 57 which drives the cuttings removing mechanism indicated generally at 58. Shaft 57 is carried adjacent its upper end by a bushing 59 pinned against rotation within the bracket 56. At its lower end, shaft 57 is keyed to and carried by the upwardly extending hub 60 of an open bottomed drum or cylinder 61 of the cuttings removing mechanism 58. Hub 60 extends into the bottom of the upstanding tubular column 55 and is bearinged therein in a bushing 62 which is locked against rotation within the column 55 by a pin 63. The bottom portion or section of skid pan 16 is made to include a vertically extending shaft 64 the axis of which is offset with respect to the axis of drive shaft 57 toward the center line of the mining machine, which center line is indicated at 65 in Fig. 1 of the drawings. There are three paddles, blades, plates or vanes 66 that are carried by the shaft 64 through spaced interfitting ears or lugs 67 that are received thereby. The side walls of cylinder or drum 61 are notched or slotted at 43 (Fig. 3) to fit over and receive the vanes 66 in spaced relation. Notches 43 are spaced approximately 120° apart in the walls of cylinder or drum 61. It will be seen that when cylinder or drum 61 is rotated, the paddles, blades, plates or vanes 66 will, because of the offset relation of the axes of shafts 57 and 64, reciprocate with respect to the drum, that is, when the vanes 66 are extending in the direction of the axis 65 of the mining machine, they will protrude from the cylinder or drum 61 and when the vanes are extending away from the axis 65 they will be retracted within the cylinder or drum 61.

The gearing for driving the cuttings removing mechanism 58 includes a large spur gear 68 carried by the large or master gear 29. Actually this spur gear and the master gear 29 may be considered as one gear wheel formed of two parts riveted or bolted together. At one side and rearwardly of the gear 29—68 is a vertical eccentric shaft 69. Shaft 69 includes a reduced diameter bottom portion 70 the axis of which is offset from the axis of the upper main body 71 of the shaft and this offset portion 70 is rotatably carried in an arm 72 of bracket 56. The upper end of shaft 69 includes an offset portion 73 which is of larger diameter than offset portion 70 but which is concentric therewith in order that the shaft 69 may be rotated. Offset portion 73 is bearinged in a collar 74 of a bracket 75 (see Fig. 3)

5

that is carried immediately below the rear cover member 76 of the machinery section 12. Endwise movement of the shaft 69 is prevented by the arm 72 of bracket 56 and a washer 77 secured to the collar 74 and overlapping the upper end of shaft 69. An arm 78 by which the shaft 69 is rotated is secured to the top of shaft 69 by bolts 79 (see Fig. 3). Arm 78 is provided at its outer end with a spring pressed knob and detent mechanism 80 the detent of which locks the arm in position seen in Figs. 1 and 3 of the drawings and which must be raised or lifted manually in order to swing the arm 78 and shaft 69.

The main body 71 of shaft 69 carries a compound reach gear wheel 81 that includes two side by side gears 82 and 83 of different diameter. Gear 82 is larger than gear 83 and is above it and it meshes with and is driven by the gear 68 of gear 29-68. Gear 83 of wheel 81 meshes with and drives a gear 84 of an overload release device 95 that is carried by and through which the shaft 57 of the cuttings removing mechanism is driven. Overload release device or clutch 85 includes a cup-like casting 86 that is keyed to the top of shaft 57 and drives the latter. The central portion of casting 86 forms an upwardly extending boss 87 which carries the gear 84 for free rotation through a bushing 88. The gear 84 and casting 86 are each provided with hardened inserts 89 that are aligned and receive a relatively soft shear pin 90 which will be sheared should the cuttings removing mechanism for any reason become jammed or overloaded to sever the driving connection between it and the gear 29-68.

It will be seen that the above described gear train for driving the cuttings removing mechanism includes the gear 28 on armature shaft 27, master gear 29-68, reach gear 81 and the overload clutch 85 including gear 84. It will also be seen that when the arm or lever 74 is rotated in a counterclockwise direction, as seen in Fig. 1 of the drawings, that the gear train for driving the cuttings removing mechanism will be broken, that is, disengaged.

When arm or lever 78 is rotated in a counterclockwise direction the teeth of gear 82 are withdrawn from the teeth or gear 68, and the teeth of gear 83 are partially withdrawn from the teeth of gear 84, that is, gears 82 and 68 are disengaged but gears 83 and 84 are not. Thus, when the compound speed reducing gear 81, including gears 82 and 83, is moved to interconnect the gears 68 and 84, only the teeth of gears 82 and 68 need to be aligned because the teeth of gears 83 and 84 are in mesh, though loosely so, until the arm or lever 78 is positioned as seen in Fig. 3, and the teeth of gears 82 and 68 are properly engaged.

Features of the above described drive and clutch mechanism are claimed in my divisional application Serial No. 271,717, filed February 15, 1952, for a Drive and Clutch Mechanism Particularly Adapted for a Mining Machine.

Referring again to Fig. 4 of the drawings, the shaft 69 which carries gear 81 is hollow and is provided with an upper and a lower oil passageway that conduct oil from the interior of the shaft 69 to the bearing surfaces between the shaft and gear 81. The interior of shaft 69 is formed so as to form a pocket or dam 91 adjacent the upper oil passageway and this pocket or dam 91 is directly below an opening 92 in arm 78 through which oil is introduced into the shaft 69. Thus oil when introduced through the opening 92 first fills the pocket 91 and then

6

overflows into the body of the shaft thereby insuring that oil will flow through the upper passageway. The top of shaft 57 has bolted thereto an oil receiving cup 93 from which oil flows downwardly through obvious passageways to lubricate the bearings on the shaft 57.

In Fig. 3 of the drawings there is illustrated by the dot-dash line 94 the path of the tips of the cutter bits 22 of cutter chain 21 as they travel under the rearward machinery section 12 of the mining machine along the rear portions of the cutter bar frame 20 and travel or sweep around the drive sprocket 46 on the bottom of drive shaft or sleeve 31. The entire path of travel of the cutter chain 21 is indicated in Fig. 1 by dot-dash line 95. As the links of the cutter chain 21 and bits 22 begin and partially complete their sweep in a counterclockwise direction around the sprocket 46 they throw kerf cuttings generally rearwardly and sidewardly into or at the kerf cuttings removing mechanism 58 which receives the cuttings in an area closely adjacent the path of travel of the cutter chain 21 and bits 22 and propels, forces, sweeps or ejects them from the mining machine. Those cuttings which are thrown directly rearwardly are deflected laterally into the cuttings removing mechanism 58 by an inwardly bent or formed wall portion 96 of the upright flange 14 of skid pan 16. Adjacent the end 97 of wall portion 96 the skid pan 16 is provided with a fixed upstanding post 98 which carries a movable plate or wall member 99. Wall member 99 is swingably carried by post 98 through ears or lugs 100 welded to the back side thereof. Wall member 99 in effect forms a movable continuation of the inwardly bent or formed laterally extending wall portion 96 of the upright side flange 14 of skid pan 16 and it is urged resiliently to swing toward the drum or cylinder 61 and the paddles, blades, plates or vanes 66 of the cuttings removing mechanism by a spring 101 that is loosely carried upon a rod or piston 102 to one end of which there is rigidly connected or attached a head 103 that is connected by a pivot pin 104 between the tines of a clevis 105 which includes the ears or lugs 100 welded to the back side of the movable wall 99. The free end of rod or piston 102 is carried by and reciprocates within a pivot block 106 mounted for pivotal swinging movement about the axis of oppositely extending aligned stub shafts, the upper one of which is seen at 107 in Fig. 3 of the drawings. The lower of the stub shafts 107 is pivotally carried directly by the skid pan 16 while the upper stub shaft 107 is pivotally carried by a plate 108 supported by and bolted to a pair of spaced upright columns 109, one at each front and rear side of the pivot block 106.

The movable wall plate 99 cooperates with the cylinder or drum 61 to form or provide an expansible way 110 through which the paddles, blades, plates or vanes 66 of the cuttings removing mechanism propel, force, sweep, feed or eject the cuttings from the mining machine and the rear portion 111 of wall 99 is bent forwardly to cause the cuttings discharged through the way 110 to be exhausted from the mining machine laterally or at one side thereof and just forwardly of the cable or rope 157.

It will be seen that when the cuttings removing mechanism is feeding cuttings out of the machine that the cuttings passing through the way 110 will be pressed against the movable wall 99 which by reason of the spring 101 and its

associated mechanism resists outward movement thereby compressing the cuttings between itself and the cylinder or drum 61. It will also be seen that should a relatively large piece of cuttings or foreign material be received by the cuttings removing mechanism 58 that the paddles, blades, plates or vanes can force it through the way 110 and expel it from the machine because the wall 99 will yield outwardly and when the large piece has been expelled the movable wall 99 will be returned by the spring and its associated mechanism to its operating position. Wall 99 is also movable to cause the cuttings removing mechanism to accommodate varying quantities of cuttings. In so doing the wall pivots or swings to cause the passageway 110 to increase or decrease in size while compressing the cuttings being fed therethrough.

In general, the operation of the mining machine is identical to that described by Nils D. Levin in his above identified patent, the only exception being in the operation of the cuttings removing mechanism 53 previously described. Because the operation of the machine and its various controls are now well known in the art as taught by Levin it is not re-described herein.

Obviously those skilled in the art may make various changes in the details and arrangement of parts without departing from the spirit and scope of the invention as defined by the claims hereto appended and applicant wishes therefore not to be restricted to the precise construction herein disclosed.

Having thus described and shown an embodiment of the invention, what it is desired to secure by Letters Patent of the United States is:

1. In a kerf cutting mining machine having a main frame and a cutter bar extending longitudinally therefrom, a drive sprocket at the rear of said cutter bar rotating on an upright axis, an endless kerf cutter chain traveling around said cutter bar and sprocket, a kerf cuttings removing mechanism including a drum and blades reciprocating therethrough rotating on an upright axis in a direction opposite to that of said sprocket positioned rearwardly and laterally of said sprocket axis whereby said blades sweep kerf cuttings thrown from said chain as it travels around said sprocket from an area closely adjacent the path of said cutter chain, guide wall means extending laterally of said main frame for directing cuttings discharged from said cutter chain in advance of said cuttings removing mechanism toward it, a movable wall means forming an extension of said wall means cooperating with

said drum to form an expansible way through which said blades force cuttings laterally from said machine adjacent the rear thereof, pivot means adjacent the end of said guide wall means mounting said movable wall means, and means resiliently resisting movement of said movable wall means away from said drum whereby said movable wall means will move to compress said cuttings and will move to accommodate varying quantities and large pieces therein.

2. In a kerf cutting mining machine having a main frame and a cutter bar extending longitudinally therefrom, a drive sprocket at the rear of said cutter bar rotating on an upright axis, an endless kerf cutter chain traveling around said cutter bar and sprocket, a kerf cuttings removing mechanism including a drum and blades reciprocating therethrough rotating on an upright axis in a direction opposite to that of said sprocket positioned rearwardly and laterally of said sprocket axis whereby said blades sweep kerf cuttings thrown from said chain as it travels around said sprocket from an area closely adjacent the path of said cutter chain, guide wall means extending laterally of said main frame for directing cuttings discharged from said cutter chain in advance of said cuttings removing mechanism toward it, said guide wall means including a movable portion cooperating with said drum to form an expansible way through which said blades force cuttings laterally from said machine, and means resiliently resisting movement of said movable wall means away from said drum whereby said movable wall means will move to compress said cuttings and will move to accommodate varying quantities and large pieces therein.

STERLING C. MOON.

References Cited in the file of this patent

UNITED STATES PATENTS

Number	Name	Date
778,699	Nelson	Dec. 27, 1904
1,082,189	Calleson	Dec. 23, 1913
1,344,013	Winkley	June 22, 1920
2,028,977	Gower	Jan. 28, 1936
2,278,119	Richards	Mar. 31, 1942
2,302,461	Richards	Nov. 17, 1942
2,320,307	Saville	May 25, 1943
2,359,422	Jeffrey	Oct. 3, 1944
2,498,606	Hyland	Feb. 12, 1950

FOREIGN PATENTS

Number	Country	Date
468,816	Great Britain	July 13, 1937