



(11) **EP 1 997 553 A2**

(12) **EUROPEAN PATENT APPLICATION**

(43) Date of publication:  
**03.12.2008 Bulletin 2008/49**

(51) Int Cl.:  
**B01F 13/00 (2006.01) B01F 5/06 (2006.01)**  
**B01F 13/10 (2006.01)**

(21) Application number: **08009659.7**

(22) Date of filing: **27.05.2008**

(84) Designated Contracting States:  
**AT BE BG CH CY CZ DE DK EE ES FI FR GB GR HR HU IE IS IT LI LT LU LV MC MT NL NO PL PT RO SE SI SK TR**  
Designated Extension States:  
**AL BA MK RS**

- **Tsudome, Hidekazu**  
**Tokyo 170-8466 (JP)**
- **Ito, Yuzuru**  
**Tokyo 170-8466 (JP)**
- **Endo, Yoshishige**  
**Tokyo 170-8466 (JP)**
- **Togashi, Shigenori**  
**Chiyoda-ku, Tokyo 100-8220 (JP)**

(30) Priority: **28.05.2007 JP 2007140279**

(71) Applicant: **Hitachi Plant Technologies, Ltd.**  
**Toshima-ku**  
**Tokyo 170-8466 (JP)**

(74) Representative: **Beetz & Partner**  
**Patentanwälte**  
**Steinsdorfstrasse 10**  
**80538 München (DE)**

(72) Inventors:  
• **Miyamoto, Tetsuro**  
**Chiyoda-ku, Tokyo 100-8220 (JP)**

(54) **Fluid mixer and method for forming mixed fluid**

(57) A fluid mixer includes: first-fluid introduction paths (11) into which a first fluid is introduced; second-fluid introduction paths (12) which are arranged alternately with the first-fluid introduction paths, and into which a second fluid is introduced; first bifurcation paths (13) formed of ends of the first-fluid introduction paths and ends of the second-fluid introduction paths, the ends bifurcating in two directions; first confluence paths (14) formed by combining ends of the first bifurcation paths with adjacent ends of different first bifurcation paths; n bifurcation paths (19) formed of ends of n-1 confluence paths (18), the ends bifurcating in two directions; n confluence paths (20) formed by combining ends of the n bifurcation paths with adjacent ends of different n bifurcation paths; and mixed-fluid discharging paths (21) formed of the n confluence paths extended to the end, the mixed-fluid discharging path for discharging a mixed fluid.

Fig. 2

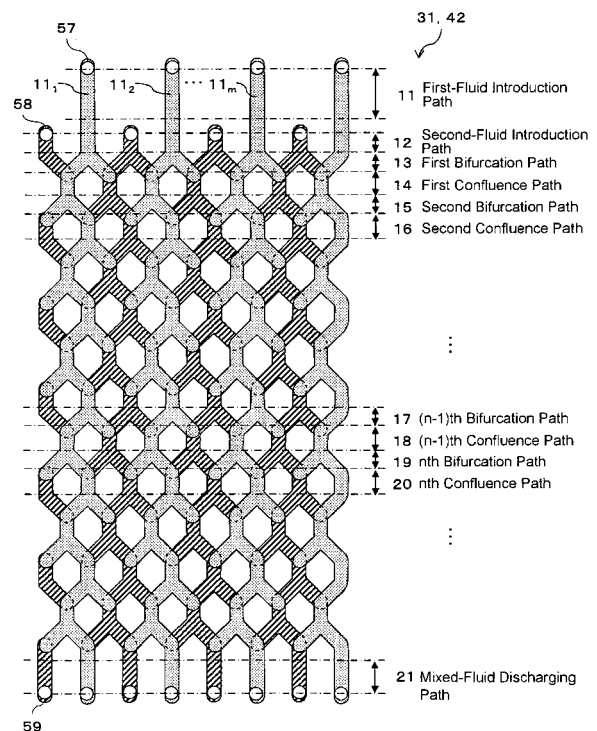

**EP 1 997 553 A2**

## Description

### BACKGROUND OF THE INVENTION

#### Field of the Invention

**[0001]** The present invention pertains to a technological field where two or more of fluids such as liquids and gases are mixed to obtain a mixed fluid. More specifically, the present invention relates to a technology to obtain this mixed fluid in the order of micrometer rapidly.

#### Description of the Related Art

**[0002]** Recently, in the field of chemical synthesis or chemical analysis, attention has been given to the following technique for shortening a reaction time and for suppressing a secondary reaction when two or more chemical substances are chemically reacted to each other. Specifically, these chemical substances are fluidized, and caused to flow through a small pore. After repeatedly converged and divided to form a homogeneous mixed fluid, the substances are chemically reacted to each other. In a fluid mixer for homogenizing such a mixed fluid with high efficiency, a flow path is formed in a substrate by a micro-fabrication technique to have a cross-section with approximately several tens to several hundreds of  $\mu\text{m}$  at one side. The fluid mixer is called a micro-mixer or a micro-reactor.

**[0003]** As such a micro-reactor, the following one has been already known. This micro-reactor includes multiple flat plates appropriately stacked on each other. Each flat plate is provided therein with multiple flow paths as grooves, the flow paths being substantially Y-shaped, and being connected with each other. In this way, a bifurcation portion on the upper side of the Y form of one of the flow paths is connected to a convergence portion on the lower side of the Y form of another one of the flow paths (see, for example, Fig. 2 and Fig. 10 in Japanese Patent Translation Publication No. Hei. 11-511689 (Patent Document 1)).

**[0004]** According to this known technique, two types of fluids put into the micro-reactor are repeatedly converged and divided, when flowing in a straight line through the multiple Y-shaped flow paths that are serially connected with each other. Thereby, the mixing of the fluids progresses.

**[0005]** Moreover, in another known example, multiple flat plates provided with through holes are stacked on each other, and the arrangement and shape of the through holes are devised in a way that two types of fluids are mixed by repeating the convergence and division as passing through the through holes (see, for example, Fig. 1 and Fig. 2 in Japanese Patent Application Publication No. 2002-346353 (Patent Document 2)).

### SUMMARY OF THE INVENTION

**[0006]** In the micro-reactor described in Patent Document 1, the number of the flow path for mixing the two types of fluids is virtually one. Thus, it is necessary to increase, to some degree, the number of stages in the Y-shaped flow paths that are connected serially with each other so as to homogenize the mixed fluid in the order of micrometer. Nevertheless, such an increase in the number of stages increases the pressure loss accompanying the flowing of the fluids. As a result, the productivity of the mixed fluid is inevitably reduced.

**[0007]** In the micro-reactor described in Patent Document 2 as well, the number of flat plates provided with the through holes need to be increased to some degree, the plate being stacked on each other so as to homogenize the mixed fluid in the order of micrometer. Nevertheless, such an increase in the number of stacked flat plates increases the thickness of the micro-reactor, and decreases the controllability on the internal temperature of the reactor. In such a case, it becomes difficult to control the chemical reaction that proceeds while involving endothermic and exothermic reactions caused by the mixing of the two types of fluids.

**[0008]** The present invention aims to solve these problems. An object of the present invention is to provide: a compact fluid mixer having an excellent temperature controllability, and high productivity of forming a highly-homogenized mixed fluid; and a method for forming such a mixed fluid.

**[0009]** To solve the above problems, the present invention provides a fluid mixer which forms a mixed fluid by mixing a first fluid and a second fluid. The fluid mixer is characterized by including multiple means that are: a group of  $m$  number ( $m=2, 3, \dots$ ) of first-fluid introduction paths into which the first fluid is introduced; a group of a plurality of second-fluid introduction paths which are arranged alternately with the first-fluid introduction paths, and into which the second fluid is introduced; a group of first bifurcation paths each formed of one of ends of the first-fluid introduction paths and ends of the second introduction paths, each end bifurcating in two directions; a group of first confluence paths each formed by combining one of the two ends of a first bifurcation path with one of the two ends of another first bifurcation path; a group of  $n$ th bifurcation paths each formed of one of ends of an  $(n-1)$ th confluence path ( $n=2, 3, \dots$ ), each end bifurcating in two directions; a group of  $n$ th confluence paths each formed by combining one of the two ends of an  $n$ th bifurcation path with one of the two ends of another  $n$ th bifurcation path; and a group of mixed-fluid discharging paths each formed of one of the  $n$ th confluence paths positioned at the end and extended, the mixed-fluid discharging path discharging the mixed fluid.

**[0010]** In such a configuration of the present invention, the multiple introduction paths into which a first fluid and a second fluid are introduced make it possible to treat mixtures of the two types of fluids in the multiple conflu-

ence paths arranged in parallel simultaneously. The multiple confluence paths arranged in parallel have the serial n number of stages with the bifurcation paths in between. Fluids are bifurcated after passing through the confluence paths at each stage. Half of the fluid thus bifurcated is converged with half of another fluid adjacent in the parallel direction, this adjacent fluid having been bifurcated similarly. These bifurcation and convergence are repeated to increase the degree of mixing the fluids without increasing the number of stages serially. Accordingly, a large number of serial stages are not required, and thus, the pressure loss accompanying the flowing of the fluids is decreased. Furthermore, since the number of the multiple first fluid and second fluid introduction paths arranged in parallel are easily increased in this configuration, it is easy to increase the amount of the first fluid and second fluid to be introduced.

**[0011]** Moreover, the flow paths through which the first fluid, the second fluid, and the mixed fluids flow, are easily formed highly densely, and also the flow paths can be formed on two or three substrates. Thereby, the flow paths occupy only a small space, and have more specific surfaces at the same time.

**[0012]** The present invention makes it possible to provide: a fluid mixer which is small in size, and which has an excellent temperature controllability and a high productivity of forming a highly-homogenized mixed fluid; and a method for forming such a mixed fluid.

#### BRIEF DESCRIPTION OF THE DRAWINGS

**[0013]** Fig. 1 is an exploded perspective view showing a fluid mixer according to a first embodiment of the present invention.

**[0014]** Fig. 2 is a plan view showing a top view of flow paths provided in the fluid mixer according to the first embodiment.

**[0015]** Figs. 3(a) to 3(c) are plan views showing top views of a first flow-path plate, a second flow-path plate, and a delivery plate, respectively, in the fluid mixer according to the first embodiment.

**[0016]** Fig. 4(a) is a partially enlarged view of Fig. 2 according to the fluid mixer of the first embodiment; Fig. 4(b) is a cross-sectional view in a Y-direction of Fig. 4(a); and Fig. 4(c) is a cross-sectional view in an X direction of Fig. 4(a).

**[0017]** Fig. 5 is an exploded perspective view showing a fluid mixer according to a second embodiment of the present invention.

**[0018]** Fig. 6 is a plan view showing a top view of flow paths provided in the fluid mixer according to the second embodiment.

**[0019]** Figs. 7(a) to 7(c) are plan views showing top views of a first flow-path plate, a third flow-path plate, and a second flow-path plate, respectively, in the fluid mixer according to the second embodiment.

**[0020]** Fig. 8(a) is a partially enlarged view of Fig. 6 according to the fluid mixer of the second embodiment;

Fig. 8(b) is a cross-sectional view in a Y-direction of Fig. 8(a); and Fig. 8(c) is a cross-sectional view in an X direction of Fig. 8(a).

#### 5 Explanation of Reference Numerals

##### [0021]

	10	fluid mixer
10	11, 11A, 11B	first-fluid introduction path
	12, 12B	second-fluid introduction path
	13, 13A, 13B, 13C	first bifurcation path (bifurcation path)
	14, 14A, 14B	first confluence path (confluence path)
15	15, 15A, 15B, 15C	second bifurcation path (bifurcation path)
	16, 16A, 16B,	second confluence path (confluence path)
20	17A, 17B, 17C	(n-1)th bifurcation path (bifurcation path)
	18, 18A, 18B	(n-1)th confluence path (confluence path)
	19, 19A, 19B, 19C	nth bifurcation path (bifurcation path)
25	20	nth confluence path (confluence path)
	21, 21A, 21B	mixed-fluid discharging path (discharging path)
30	30	first flow-path plate (flow-path plate)
	31	first flow path (flow path)
	40	second flow-path plate (flow-path plate)
	42	second flow path (flow path)
35	50	delivery plate
	51	first-fluid inlet path (inlet path)
	52	second-fluid inlet path (inlet path)
	54	mixed-fluid outlet path (outlet path)
	60	third flow-path plate (flow-path plate)
40	63	third flow path (flow path)

#### DETAILED DESCRIPTION OF THE PREFERRED EMBODIMENTS

##### 45 First embodiment

**[0022]** Description will be given of a first embodiment of the present invention with reference to Fig. 1 to Fig. 4 (c).

**[0023]** As shown in an exploded perspective view of Fig. 1, a fluid mixer 10 of the first embodiment is configured of a delivery plate 50 as well as a first flow-path plate 30 and a second flow-path plate 40 that are stacked on the delivery plate 50.

**[0024]** The fluid mixer 10 configured in this manner receives a first fluid and a second fluid from inlet paths 51, 52, respectively, in the delivery plate 50. Then, the

fluids flow through flow paths 31, 42 (see Fig. 2 as necessary) formed in the respective flow-path plates 30, 40, and the fluids are mixed with each other. Consequently, the fluid mixer 10 outputs the fluids as a mixed fluid from an outlet path 54 in the delivery plate 50.

**[0025]** The first flow path 31 is formed into a groove shape by carving one surface (lower surface in the drawing) of the first flow-path plate 30. The second flow path 42 is formed into a groove shape by carving one surface (upper surface in the drawing) of the second flow-path plate 40. The first flow-path plate 30 and the second flow-path plate 40 are brought into contact with each other on those surfaces where the flow paths are carved. Thereby, formed are flow paths (see Fig. 2 as necessary) through which the first and second fluids flow and mix together.

**[0026]** Moreover, a sealing groove 33 is carved in the first flow-path plate 30 as surrounding the first flow path 31. A sealing groove 43 is carved in the second flow-path plate 40 as surrounding the second flow path 42. According, by inserting a sealing member 25 into the sealing grooves 33, 43, the fluids flowing through the first flow path 31 and the second flow path 42 are prevented from leaking out.

**[0027]** Additionally, sealing grooves 53, 53 are carved in the delivery plate 50. The sealing grooves are for inserting sealing members (unillustrated) disposed between the delivery plate 50 and the second flow-path plate 40. The sealing grooves 53, 53 are carved as surrounding a group of first dividing holes 57 through which the first fluid passes, a group of second dividing holes 58 through which the second fluid passes, and a group of third dividing holes 59 through which the mixed fluid passes. Thereby, the first fluid, the second fluid and the mixed fluid between the contact surfaces of the delivery plate 50 and the second flow-path plate 40 are prevented from leaking out, and also the fluids are prevented from mixing with one another.

**[0028]** Furthermore, fastening holes 35, 45, 55 are provided at the respective peripheries of the first flow-path plate 30, the second flow-path plate 40 and the delivery plate 50. The fastening hole is for inserting a fastening member (the illustration is omitted) which fixes these plates stacked on each other. Still furthermore, positioning holes 36, 46, 56 are provided for positioning the first flow path 31, the second flow path 42 and the dividing holes 57, 58, 59 as predetermined (see Fig. 2 as necessary).

**[0029]** The material of the first flow-path plate 30, the second flow-path plate 40 and the delivery plate 50 can be appropriately selected among, for example, metals, silicon, glasses, plastic materials, in accordance with the fluids. Moreover, the dimensions such as the width, depth, and the like of the flow paths 31, 42 preferably range from approximately several tens of  $\mu\text{m}$  to several mm. For processing the flow paths 31, 42, a method of etching, machine processing, or the like, can be appropriately selected.

**[0030]** Meanwhile, in the fluid mixer 10 illustrated in

this embodiment, the flow paths 31, 42 are disposed on a two-dimensional plane. Accordingly, the fluid mixer 10 is in a plate-like form, and has a large specific area as illustrated. Thus, the fluid mixer 10 has an excellent characteristic of a temperature controllability.

**[0031]** For this reason, in a case, for example, where the fluid mixer 10 illustrated in this embodiment is used as a chemical reactor, in controlling the temperature, the entire fluid mixer 10 may be installed in a thermostat (unillustrated), or the fluid mixer 10 may be provided on the top and bottom flat surfaces with a heat adjustment means such as a heater, a Peltier device or a hot water jacket (unillustrated).

**[0032]** The description will be further continued with reference to Fig. 2.

**[0033]** Fig. 2 is a plan view showing a configuration of the flow paths observed from the top surface of the fluid mixer 10 according to the first embodiment, and the first flow path 31 and the second flow path 42 are superimposed on each other. Moreover, exemplified are the flow paths 31, 42 as shown in Fig. 2, in which combinations between bifurcation paths 13, 15, 17, 19 and confluence paths 14, 16, 18, 20 are formed in multiple stages (12 stages in the drawing) in series in which the fluids flow, and in which combinations between the first-fluid introduction paths 11 and second-fluid introduction paths 12 are formed in multiple rows (4 rows in the drawing) in a parallel direction which is perpendicular to the serial direction.

**[0034]** Into the first-fluid introduction paths 11 ( $11_1, 11_2, \dots, 11_m$ ), the first fluids are introduced from the first dividing holes 57 in the delivery plate 50 (see Fig. 1). The multiple first-fluid introduction paths 11 (4 in the drawing) are arranged in parallel to a direction perpendicular to the direction in which the first fluid flows, thereby forming a group.

**[0035]** Into the second-fluid introduction paths 12, the second fluids are introduced from the second dividing holes 58 in the delivery plate 50 (see Fig. 1). The multiple second-fluid introduction paths 12 (4 in the drawing) are arranged alternately with the first-fluid introduction paths 11, thereby forming a group.

**[0036]** The first bifurcation path 13 is formed of an end of the first-fluid introduction path 11 bifurcating into two in the first-fluid flowing direction, as well as an end of the second-fluid introduction path 12 bifurcating into two in the second-fluid flowing direction. These ends are disposed alternately in parallel, thereby forming a group of first bifurcation paths 13.

**[0037]** The first confluence path 14 is formed by combining one of the two ends of a first bifurcation path 13 with one of the two ends of another (adjacent) first bifurcation path 13. The multiple first confluence paths 14 are disposed alternately in parallel, thereby forming a group.

**[0038]** The second bifurcation path 15 is formed of the ends of the first confluence path 14 bifurcating into two in the fluid flowing direction. The multiple second bifurcation paths 15 are disposed in parallel, thereby forming

a group.

**[0039]** The second confluence path 16 is formed by combining one of the two ends of a second bifurcation path 15 with one of the two ends of another (adjacent) second bifurcation path 15. The multiple second confluence paths 16 are disposed in parallel, thereby forming a group.

**[0040]** As described above, in a case where the combination between the group of the first bifurcation paths 13 and the group of the first confluence paths 14 is defined as the first stage and where the combination between the group of second bifurcation paths 15 and the group of second confluence paths 16 is defined as the second stage, the flow paths 31, 42 are configured of an arbitrary number of stages (n stages) connected serially.

**[0041]** In this respect, the nth bifurcation path 19 in the nth stage is formed of the ends of the (n-1)th confluence path 18 (n=2, 3, ...), the ends being bifurcating in two directions. The multiple nth bifurcation paths 19 are disposed in parallel, thereby forming a group.

**[0042]** Moreover, the nth confluence path 20 is formed by combining one of the two ends of an nth bifurcation path 19 with one of the two ends of another (adjacent) nth bifurcation path 19. The multiple nth confluence paths 20 are disposed alternately in parallel, thereby forming a group.

**[0043]** A mixed-fluid discharging path 21 is formed of the nth confluence path 20 positioned at the end (last stage) of the fluid-flowing direction and extended. The mixed-fluid discharging path 21 is a portion to discharge the fluids mixed by repeatedly converging and dividing the first fluids and the second fluids at each stage multiple times (n times), and is connected with the third dividing hole 59 in the delivery plate 50 (see Fig. 1).

**[0044]** The description will be further continued with reference to Figs. 3(a) to 3(c).

**[0045]** Fig. 3(a) is a plan view showing the first flow-path plate 30 observed from the top surface of the fluid mixer 10 (see Fig. 1). The first flow paths 31 and the sealing groove 33 shown by dashed lines are carved in the opposite surface. Fig. 3(b) is a plan view showing the second flow-path plate 40 observed from the top surface of the fluid mixer 10. The flow paths 42 and the sealing groove 43 shown by solid lines are carved in this surface.

**[0046]** The first flow-path plate 30 is provided with a first bifurcation path 13A among the group of the first bifurcation paths 13 (see Fig. 2), the first bifurcation path 13A bifurcating from a first-fluid introduction path 11 A. Moreover, the first flow-path plate 30 is provided with an (n-1)th bifurcation path 17A (n=2, 3, ...), and an (n-1)th confluence path 18A (n=2, 3, ...) and an nth bifurcation path 19A connected with one end of the path 17A. Meanwhile, the other end of the (n-1)th bifurcation path 17A of the first flow-path plate 30 is connected with an (n-1)th confluence path 18B (n=2, 3, ...) and an nth bifurcation path 19B provided to the second flow-path plate 40.

**[0047]** The second flow-path plate 40 is provided with a first bifurcation path 13B among the group of the first

bifurcation paths 13 (see Fig. 2), the first bifurcation path 13B bifurcating from a second-fluid introduction path 12B. Moreover, the second flow-path plate 40 is provided with an (n-1)th bifurcation path 17B (n=2, 3, ...), and the (n-1)th confluence path 18B (n=2, 3, ...) and the nth bifurcation path 19B connected with one end of the path 17B. Meanwhile, the other end of the (n-1)th bifurcation path 17B of the second flow-path plate 40 is connected with the (n-1)th confluence path 18A (n=2, 3, ...) and the nth bifurcation path 19A provided to the first flow-path plate 30.

**[0048]** Fig. 3(c) is a plan view showing the delivery plate 50 observed from the top surface of the fluid mixer 10 (see Fig. 1). The dividing holes 57, 58, 59 shown by solid lines are openings in this surface. The sealing grooves 53 are also carved in this surface.

**[0049]** The first-fluid inlet path 51 communicates with the group of the first-fluid introduction paths 11A on the first flow-path plate 30 via the first dividing holes 57 of the delivery plate 50 and passage holes 47B of the second flow-path plate 40. When the first fluid is received from the opening edge of the first-fluid inlet path 51 opening on the side surface of the delivery plate 50, this first fluid is introduced into the first-fluid introduction paths 11A.

**[0050]** The second-fluid inlet path 52 communicates with the group of the second-fluid introduction paths 12B on the second flow-path plate 40 via the second dividing holes 58 of the delivery plate 50. When the second fluid is received from the opening edge of the second-fluid inlet path 52 opening on the side surface of the delivery plate 50, this second fluid is introduced into the second-fluid introduction paths 12B.

**[0051]** The mixed-fluid outlet path 54 communicates with the group of mixed-fluid discharging paths 21B on the second flow-path plate 40 via the third dividing holes 59 of the delivery plate 50, and also communicates with a group of mixed-fluid discharging paths 21A on the first flow-path plate 30 via passage holes 49B. The mixed fluid obtained by flowing the first fluid and the second fluid through the flow paths 31, 42 is outputted from this mixed-fluid outlet path 54.

**[0052]** As described above, the flow paths 31, 42 through which the first fluid and the second fluid flow to form the mixed fluid can be configured by stacking at least two flow-path plates. Moreover, the converging and dividing of the fluids are repeated while the fluids flowing through these flow paths 31, 42 are curved only to a small extent. Thereby, the pressure loss in the fluids is small, and it is easy to let a large amount of fluids flow. Furthermore, the flow paths are expanded two-dimensionally on the flat surface. Thus, the area generating and receiving heat is large, and the flow paths have an excellent characteristic on a heat controllability.

**[0053]** Next, description will be given of an operation of the fluid mixer according to the first embodiment with reference to Figs. 4(a) to 4(c).

**[0054]** Fig. 4(a) is a partially enlarged view of Fig. 2,

including the first dividing hole 57 and the second dividing hole 58 of the fluid mixer according to the first embodiment. Fig. 4(b) shows cross-sectional views in Y1 and Y2 directions of Fig. 4(a). Fig. 4(c) shows cross-sectional views in X1, X2, X3 and X4 directions of Fig. 4(a).

**[0055]** Firstly, first fluids introduced from the first dividing holes 57 flow in a serial direction of the first-fluid introduction paths 11A, 11A (first-fluid receiving stage). Simultaneously, a second fluid introduced from the second dividing hole 58 flows in a serial direction of the second-fluid introduction path 12B (second-fluid receiving stage).

**[0056]** Then, the first fluids flowing through the first-fluid introduction paths 11A, 11A bifurcate and flow in two directions at the first bifurcation paths 13A, 13A; simultaneously, the second fluid flowing through the second-fluid introduction path 12B bifurcates and flows in two directions at the first bifurcation path 13B (first bifurcation stage).

**[0057]** At this first bifurcation stage, the first fluids and the second fluids are bifurcated at the first bifurcation paths 13A, 13B, respectively, and continue to flow without mixing with each other as shown by the cross-sections in Y1 and Y2 of Fig. 4(b) and by the cross-section in X1 of Fig. 4(c).

**[0058]** Subsequently, one of the first fluids bifurcated in the two directions at the first bifurcation path 13A is converged with one of the second fluids bifurcated in the two directions at the second-fluid introduction path 12B. Then, this converged fluid flows in the serial direction of a first confluence paths 14A and 14B (first confluence stage).

**[0059]** At this first confluence stage, the first fluids flowing through the respective first bifurcation paths 13A and the second fluids flowing through the respective first bifurcation paths 13B converge with each other at the first confluence paths 14A, 14B to form two-layer fluids while maintaining laminar flow states as shown by the cross-sections in Y1 and Y2 of Fig. 4(b) and by the cross-section in X2 of Fig. 4(c).

**[0060]** Thereafter, the two-layer fluids converged at the (n-1)th confluence stage (n=2) described above are further bifurcated in two directions at nth bifurcation paths 15A, 15B (n=2), respectively (nth bifurcation stage).

**[0061]** At this nth bifurcation stage (n=2), the above-described two-layer fluids are bifurcated at the second bifurcation paths 15A, 15B, and continue to flow while maintaining the laminar states as shown by the cross-sections in Y1 and Y2 of Fig. 4(b) and by the cross-section in X3 of Fig. 4(c).

**[0062]** Furthermore, one of the fluids bifurcated from a fluid in the two directions is converged with one of the fluids bifurcated from another fluid in the two directions. Then, this converged fluid flows in a serial direction of an nth confluence path 16A or 16B (n=2) (nth confluence stage).

**[0063]** At this nth confluence stage (n=2), the two-layer fluids flowing through the respective second bifurcation paths 15A and the two-layer fluids flowing through the

respective second bifurcation paths 15B converge with each other at the second confluence paths 16A, 16B to form four-layer fluids while maintaining laminar flow states as shown by the cross-sections in Y1 and Y2 of Fig. 4(b) and by the cross-section in X4 of Fig. 4(c).

**[0064]** After that, by further repeatedly providing multiple stages (n=3, 4 ...) of the above-described nth bifurcation stage and nth confluence stage, the thinner first and second fluids are alternately laminated on each other to form multi-layer fluids, while the mixing progresses. In this way, the converging and dividing are alternately repeated n times, and the number of lamination of the fluid becomes the nth power of 2.

**[0065]** Lastly, fluids obtained at the last stage of the above-described n confluence stages are discharged as mixed fluids from the discharging paths 21 (see Fig. 2) (mixed-fluid discharging stage). In this manner, by mixing the first and second fluids, it is possible to obtain a mixed fluid homogenized in the order of micrometer within a short period of time without increasing the pressure loss accompanying the flowing of the fluids.

#### Second embodiment

**[0066]** Next, description will be given of a second embodiment of the present invention with reference to Fig. 5 to Fig. 8(c). Note that, among members constituting a fluid mixer 10 of the second embodiment, those which have the same configurations and operations as those described in the first embodiment are denoted by the same reference numerals in the drawings. Hereinafter, the description already given is incorporated, and thus specific description will be omitted.

**[0067]** As shown in an exploded perspective view of Fig. 5, a fluid mixer 10 of the second embodiment is configured of the delivery plate 50 as well as the first flow-path plate 30, the second flow-path plate 40, and a third flow-path plate 60 that are stacked on the delivery plate 50.

**[0068]** The fluid mixer 10 configured in this manner receives a first fluid and a second fluid from the inlet paths 51, 52, respectively, in the delivery plate 50. Then, the fluids flow through the flow paths 31, 42 and another flow path 63 (see Fig. 6 as necessary) formed in the respective flow-path plates 30, 40, 60, and the fluids are mixed with each other. Consequently, the fluid mixer 10 outputs the fluids as a mixed fluid from the outlet path 54 in the delivery plate 50.

**[0069]** Fig. 6 is a plan view showing a configuration of the flow paths observed from the top surface of the fluid mixer 10 (see Fig. 5) according to the second embodiment. The first flow path 31, the second flow path 42, and the third flow path 63 are superimposed on each other.

**[0070]** Note that, the specific descriptions of the flow paths 31, 42, 63 shown in Fig. 6 are the same as those already described with reference to Fig. 2. Hereinafter, the descriptions are incorporated, and thus specific descriptions will be omitted.

**[0071]** The description will be further continued with reference to Figs. 7(a) to 7(c).

**[0072]** Fig. 7(a) is a plan view showing the first flow-path plate 30 observed from the top surface of the fluid mixer 10 (see Fig.5). The first flow paths 31 and the sealing groove 33 shown by dashed lines are carved in the opposite surface. Fig. 7(b) is a plan view showing the third flow-path plate 60 observed from the top surface of the fluid mixer 10 (see Fig. 5). The flow paths 63 shown by solid lines are through-holes and the sealing grooves 61, 62 are carved in both surfaces. Fig. 7(c) is a plan view showing the second flow-path plate 40 observed from the top surface of the fluid mixer 10 (see Fig. 5). The second flow paths 42 and the sealing groove 43 shown by solid lines are carved in this surface.

**[0073]** The first flow-path plate 30 is provided with the first bifurcation path 13A among the group of the first bifurcation paths 13 (see Fig. 6), the first bifurcation path 13A bifurcating from a first-fluid introduction path 11B that is provided to the third flow-path plate 60. Moreover, the first flow-path plate 30 is provided with the (n-1)th bifurcation path 17A (n=2, 3, ...), and the nth bifurcation path 19A connected with one end of the path 17A. Meanwhile, the other end of the (n-1)th bifurcation path 17A (n=2, 3, ...) of the first flow-path plate 30 is connected with an nth bifurcation path 19C provided to the second flow-path plate 40. The (n-1)th bifurcation path 17A, an (n-1)th bifurcation path 17C and the nth bifurcation path 19A are jointed with the (n-1)th confluence path 18B that is provided to the third flow-path plate 60.

**[0074]** The second flow-path plate 40 is provided with a first bifurcation path 13C among the group of the first bifurcation paths 13 (see Fig. 6), the first bifurcation path 13C bifurcating from the second-fluid introduction path 12B. Moreover, the second flow-path plate 40 is provided with the (n-1)th bifurcation path 17C (n=2, 3, ...), and the nth bifurcation path 19C connected with one end of the path 17C. Meanwhile, the other end of the (n-1)th bifurcation path 17C of the second flow-path plate 40 is connected with the nth bifurcation path 19A provided to the first flow-path plate 30. The (n-1)th bifurcation path 17A, the (n-1)th bifurcation path 17C and the nth bifurcation path 19A are jointed with the (n-1)th confluence path 18B that is provided to the third flow-path plate 60.

**[0075]** Passage holes 47C provided in the second flow-path plate 40 cause the group of the first-fluid introduction paths 11B on the third flow-path plate 60 and the first dividing holes 57 of the delivery plate 50 (see Fig. 5) to communicate with each other. Passage holes 48C cause the group of the second-fluid introduction paths 12B on the third flow-path plate 60 and the second dividing holes 58 of the delivery plate 50 (see Fig. 5) to communicate with each other. Passage holes 49C cause the group of the mixed-fluid discharging paths 21 on the third flow-path plate 60 and the third dividing holes 59 of the delivery plate 50 (see Fig. 5) to communicate with each other.

**[0076]** In this manner, the flow paths 31, 42, 63 through

which the first fluid and the second fluid flow to form a mixed fluid are configured by stacking the three flow-path plates.

**[0077]** Next, description will be given of an operation of the fluid mixer according to the second embodiment with reference to Figs. 8(a) to 8(c).

**[0078]** Fig. 8(a) is a partially enlarged view of Fig. 6 including the first dividing hole 57 and the second dividing hole 58. Fig. 8(b) shows cross-sectional views in Y1 and Y2 directions of Fig. 8(a). Fig. 8(c) shows cross-sectional views in X1, X2, X3 and X4 directions of Fig. 8(a).

**[0079]** Firstly, first fluids introduced from the first dividing holes 57, 57 flow in a serial direction of the first-fluid introduction paths 11 B, 11 B (first-fluid receiving stage). Simultaneously, a second fluid introduced from the second dividing hole 58 flows in a serial direction of the second-fluid introduction path 12B (second-fluid receiving stage).

**[0080]** Then, the first fluids flowing through the first-fluid introduction paths 11B, 11B bifurcate and flow in two directions at the first bifurcation paths 13A, 13A; simultaneously, the second fluid flowing through the second-fluid introduction path 12B bifurcates and flows in two directions at the first bifurcation path 13C (first bifurcation stage).

**[0081]** At this first bifurcation stage, the first fluids and the second fluids are bifurcated at the first bifurcation paths 13A, 13C, respectively, and continue to flow without mixing with each other as shown by the cross-sections in Y1 and Y2 of Fig. 8(b) and by the cross-section in X1 of Fig. 8(c).

**[0082]** Subsequently, one of the first fluids bifurcated in the two directions at the first bifurcation path 13A is converged with one of the second fluids bifurcated in the two directions at the first bifurcation path 13C. Then, this converged fluid flows in serial directions of the first confluence path 14B (first confluence stage).

**[0083]** At this first confluence stage, the first fluids flowing through the respective first bifurcation paths 13A and the second fluids flowing through the respective first bifurcation paths 13C converge with each other after crashing head-on at the ends of the first confluence paths 14B as shown by the cross-sections in Y1 and Y2 of Fig. 8(b) and by the cross-section in X2 of Fig. 8(c). Thus, swirled fluids are formed with swirl flows at the first confluence paths 14B.

**[0084]** Thereafter, the swirled fluids converged at the (n-1)th confluence stage (n=2) described above are further bifurcated in two directions at the nth bifurcation path 15A, and an nth bifurcation path 15C (n=2), respectively (nth bifurcation stage).

**[0085]** At this nth bifurcation stage (n=2), the above-described swirled fluids are bifurcated at the second bifurcation paths 15A, 15C, and continue to flow while maintaining the swirl flows as shown by the cross-sections in Y1 and Y2 of Fig. 8(b) and by the cross-section in X3 of Fig. 8(c).

**[0086]** Furthermore, one of the fluids bifurcated from

a fluid in the two directions is converged with one of the fluids bifurcated from another fluid in the two directions. Then, this converged fluid flows in a serial direction of the nth confluence path 16B (n=2) (nth confluence stage).

**[0087]** At this nth confluence stage (n=2), the swirled fluids flowing through the respective second bifurcation paths 15A and the swirled fluids flowing through the respective second bifurcation paths 15C converge with each other after crashing head-on at the ends of the second confluence paths 16B as shown by the cross-sections in Y1 and Y2 of Fig. 8(b) and by the cross-section in X4 of Fig. 8(c). Thus, more complex swirled fluids are formed at the second confluence paths 16B.

**[0088]** After that, by further repeatedly providing multiple stages (n=3, 4 ...) of the above-described nth bifurcation stage and nth confluence stage, the thinner first and second fluids are alternately laminated on each other to form swirled fluids, while the mixing progresses.

**[0089]** Lastly, fluids obtained at the last stage of the above-described nth confluence stages are discharged as mixed fluids from the discharging paths 21 (see Fig. 6) (mixed-fluid discharging stage). Accordingly, in the second embodiment, by mixing the first and second fluids while the converging/swirling/dividing are repeated, it is possible to obtain a homogeneous mixed fluid that is divided more minutely than in the first embodiment.

**[0090]** The above-described embodiments are merely examples for explaining the present invention. The present invention is not limited to the above embodiments, and various modifications can be made within the scope of the invention. For instance, the fluid mixer 10 is configured of the delivery plate 50 disposed therein; however, this delivery plate 50 is not an essential component. It is possible to adopt a configuration in which a first fluid and a second fluid are directly poured into the first flow path 31 and the second flow path 42, respectively, or in which a first fluid and a second fluid are directly poured into the third flow path 63. Moreover, in the embodiments, the stacked flow-path plates are hermetically sealed with a sealing material and fixed with the fastening member; however, the flow-path plates may be hermitically sealed and fixed by a method of adhering, bonding, or the like, without the sealing material.

**[0091]** Furthermore, in the present embodiments, the flow paths 31, 42, 63 are formed by carving or drilling the plate materials; however, the flow paths may be configured of tubular pipes.

**[0092]** Additionally, in the method for forming a mixed fluid, the components of the mixed fluid to be formed are not limited to two types. By introducing, as the first fluid and the second fluid, fluids in which a number of components are blended at predetermined proportions in advance, it is possible to form a mixed fluid in which three types or more of components are mixed.

## Claims

1. A fluid mixer (10) which forms a mixed fluid by mixing a first fluid and a second fluid, the fluid mixer (10) comprising:

a group of m number (m = 2, 3, ...) of first-fluid introduction paths (11, 11A, 11B) into which the first fluid is introduced;

a group of a plurality of second-fluid introduction paths (12, 12B) which are arranged alternately with the first-fluid introduction paths (11, 11A, 11B) and into which the second fluid is introduced;

a group of first bifurcation paths (13, 13A, 13B, 13C) each formed of one of ends of the first-fluid introduction paths (11, 11A, 11B) and ends of the second introduction paths (12, 12B), each end bifurcating in two directions;

a group of first confluence paths (14, 14A, 14B) each formed by combining one of the two ends of a first bifurcation path (13, 13A, 13B, 13C) with one of the two ends of another first bifurcation path (13, 13A, 13B, 13C);

a group of nth bifurcation paths (17A, 17B, 17C) each formed of one of ends of an (n-1)th confluence path (14, 14A, 14B) (n = 2, 3, ...), each end bifurcating in two directions;

a group of nth confluence paths (16, 16A, 16B) each formed by combining one of the two ends of an nth bifurcation path (13, 13A, 13B, 13C) with one of the two ends of another nth bifurcation path (15, 15A, 15B, 15C);

a group of mixed-fluid discharging paths (21, 21A, 21B) each formed of one of the nth confluence paths (20) positioned at the end and extended, the mixed-fluid discharging path (21, 21A, 21B) discharging the mixed fluid.

2. The fluid mixer (10) according to claim 1, further comprising:

a first flow-path plate (30) provided with the first bifurcation paths (13, 13A, 13B, 13C) bifurcating from the first-fluid introduction paths (11, 11A, 11B) among the group of the first bifurcation paths (13, 13A, 13B, 13C); and

a second flow-path plate (40) provided with the first bifurcation paths (13, 13A, 13B, 13C) bifurcating from the second-fluid introduction paths (12, 12B) among the group of the first bifurcation paths (13, 13A, 13B, 13C), wherein the (n-1)th bifurcation paths (17A, 17B, 17C) (n = 2, 3, ...), and the (n-1)th confluence paths (18, 18A, 18B) (n = 2, 3, ...) and the nth bifurcation paths (19, 19A, 19B, 19C) connected with one ends of the respective (n-1)th bifurcation paths (17A, 17B, 17C) are provided to any one of the

first flow-path plate (30) and the second flow-path plate (40), and the (n-1)th confluence paths (18, 18A, 18B) (n = 2, 3, ...) and the nth bifurcation paths (19, 19A, 19B, 19C) connected with the other ends of the respective (n-1)th bifurcation paths (17A, 17B, 17C) (n = 2, 3, ...) are provided to one of the first and second flow-path plates (30, 40) that is different from that provided with the (n-1)th bifurcation paths (17A, 17B, 17C).

3. The fluid mixer (10) according to claim 1, further comprising:

a first flow-path plate (30) provided with the first bifurcation paths (13, 13A, 13B, 13C) bifurcating from the first-fluid introduction paths (11, 11A, 11B) among the group of the first bifurcation paths (13, 13A, 13B, 13C);  
 a second flow-path plate (40) provided with the first bifurcation paths (13, 13A, 13B, 13C) bifurcating from the second-fluid introduction paths (12, 12B) among the group of the first bifurcation paths (13, 13A, 13B, 13C); and  
 a third flow-path plate (60), wherein the (n-1)th bifurcation paths (17A, 17B, 17C) (n = 2, 3, ...) and the nth bifurcation paths (19, 19A, 19B, 19C) connected with one ends of the respective (n-1)th bifurcation paths (17A, 17B, 17C) are provided to any one of the first flow-path plate (30) and the second flow-path plate (40),  
 the nth bifurcation paths (19, 19A, 19B, 19C) connected with the other ends of the respective (n-1)th bifurcation paths (17A, 17B, 17C) (n = 2, 3, ...) are provided to one of the first and second flow-path plates (30, 40) that is different from that provided with the (n-1)th bifurcation paths (17A, 17B, 17C), and  
 n-1 confluence paths (18, 18A, 18B) that connect the nth bifurcation paths (19, 19A, 19B, 19C) with the (n-1)th bifurcation paths (17A, 17B, 17C) are provided to the third flow-path plate (60).

4. The fluid mixer (10) according to any of claims 2 and 3, further comprising

a delivery plate (50) including:

a first-fluid inlet path (51) which communicates with the group of the first-fluid introduction paths (11, 11A, 11B), and which receives the first fluid;  
 a second-fluid inlet path (52) which communicates with the group of the second-fluid introduction paths (12, 12B) and which receives the second fluid; and

a mixed-fluid outlet path (54) which communicates with the group of the mixed-fluid discharging paths (21, 21A, 21B), and which outputs the mixed fluid,

wherein the first flow-path plate (30) and the second flow-path plate (40) are stacked on the delivery plate (50).

5. A method for forming a mixed fluid by mixing a first fluid and a second fluid, the method comprising:

a first-fluid receiving stage of introducing the first fluid into a group of m number (m = 2, 3, ...) of first-fluid introduction paths (11, 11A, 11B);  
 a second-fluid receiving stage of introducing the second fluid into a group of a plurality of second-fluid introduction paths (12, 12B) which are arranged alternately with the first-fluid introduction paths (11, 11A, 11B);  
 a first bifurcation stage of bifurcating the first fluid flowing through each of the first-fluid introduction paths (11, 11A, 11B) in two directions and bifurcating the second fluid flowing through each of the second-fluid introduction paths (12, 12B) in two directions;  
 a first confluence stage of converging one of the first fluid bifurcated in the two directions with one of the second fluid bifurcated in the two directions;  
 an nth bifurcation stage of further bifurcating each converged fluid at an (n-1)th confluence stage (n = 2, 3, ...) in two directions;  
 an nth confluence stage of converging one of the fluids bifurcated from a fluid in the two directions at the nth bifurcation stage with one of the fluids bifurcated from another fluid in the two directions at the nth bifurcation stage; and  
 a mixed-fluid discharging stage of discharging the fluid obtained as the mixed fluid at the last stage of the n confluence stages.

Fig. 1

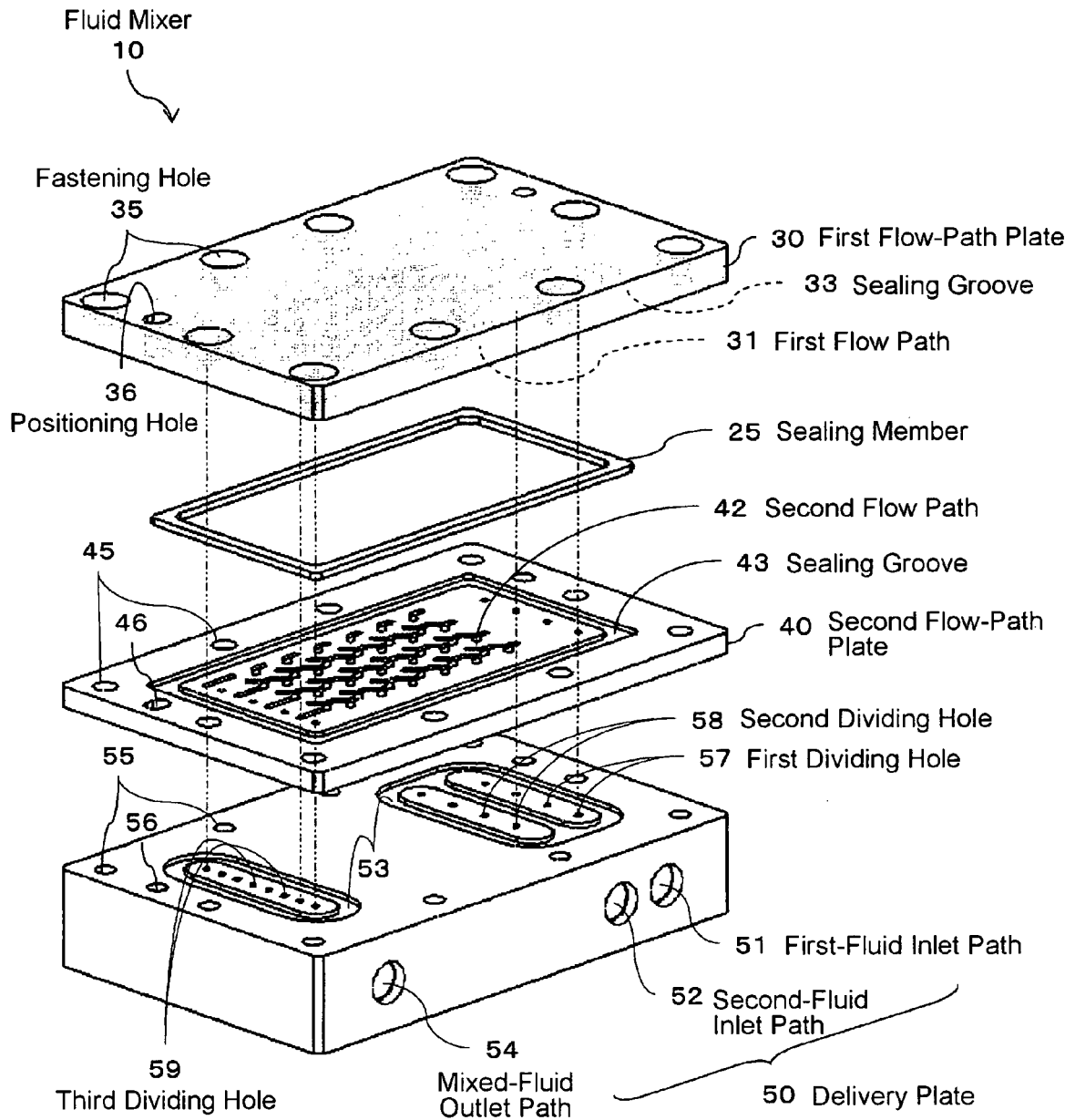

Fig. 2

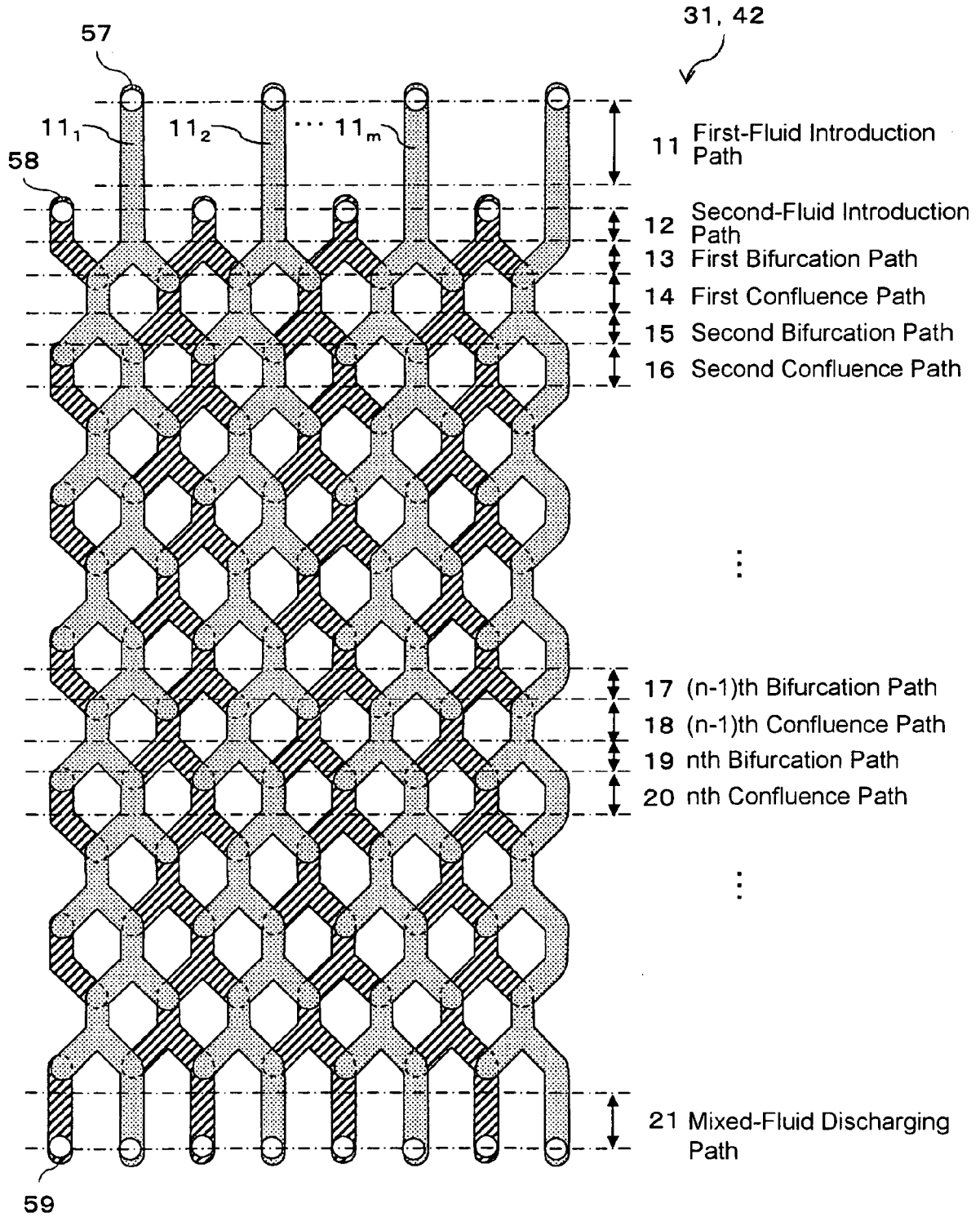

Fig. 3

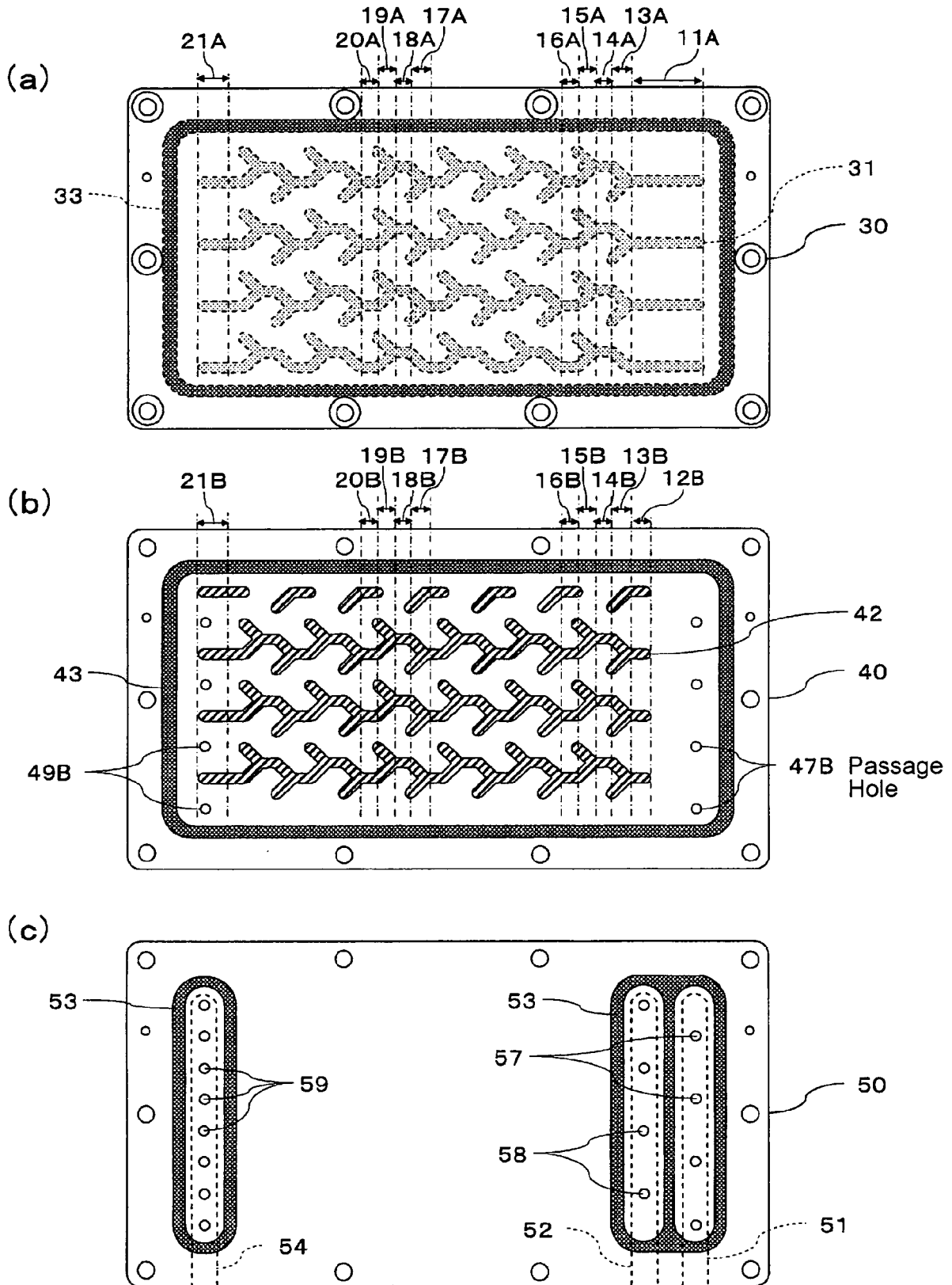

Fig. 4

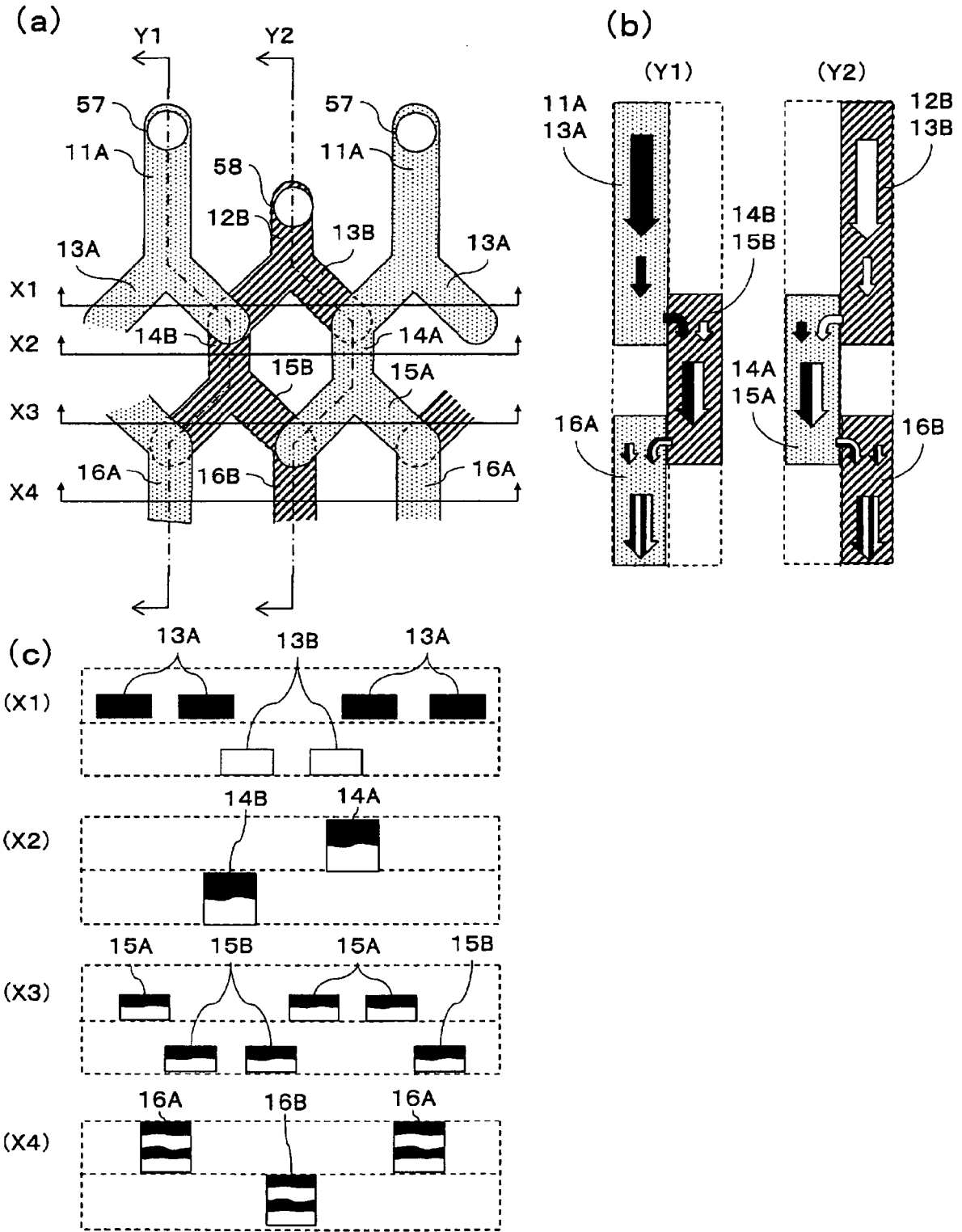

Fig. 5

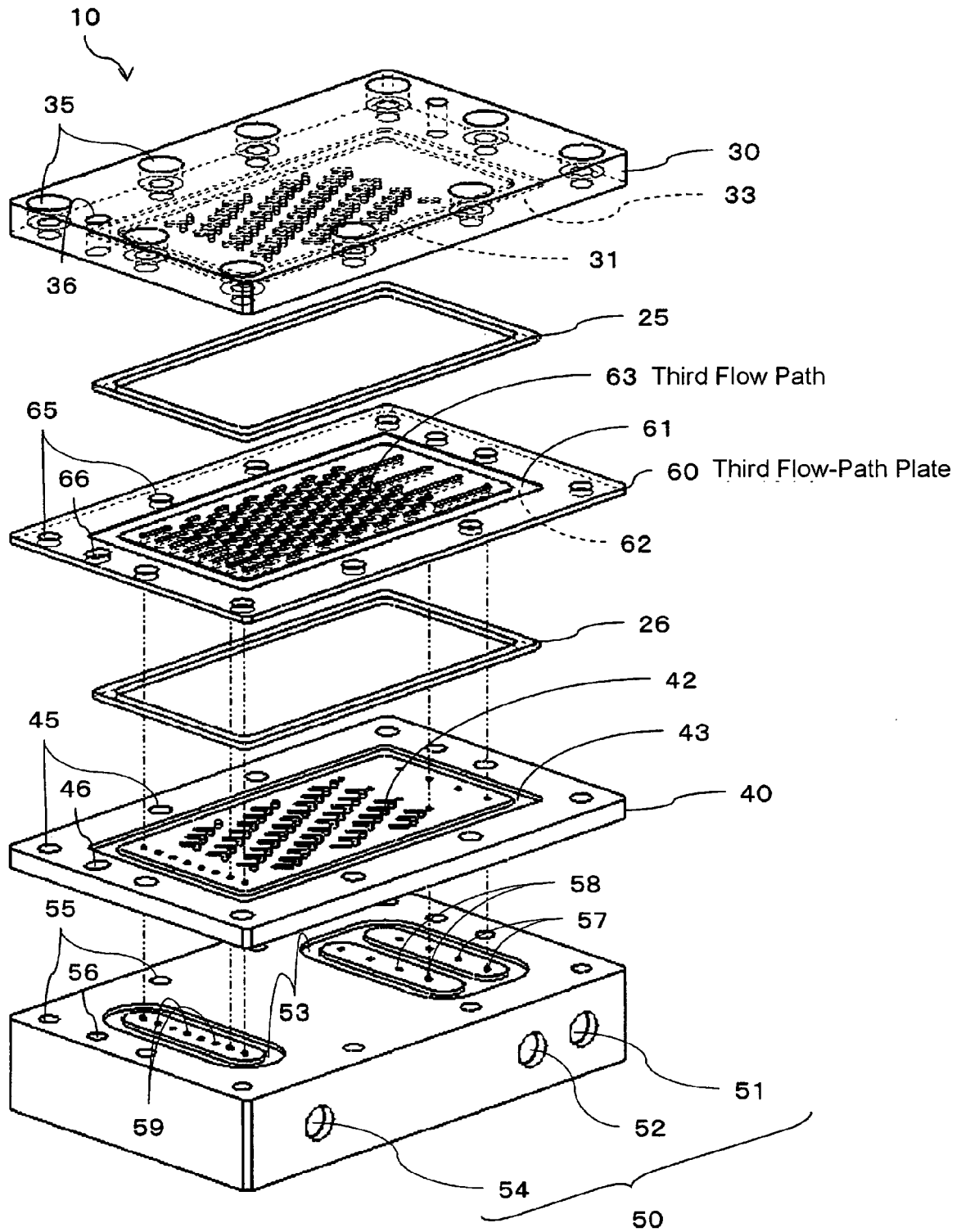

Fig. 6

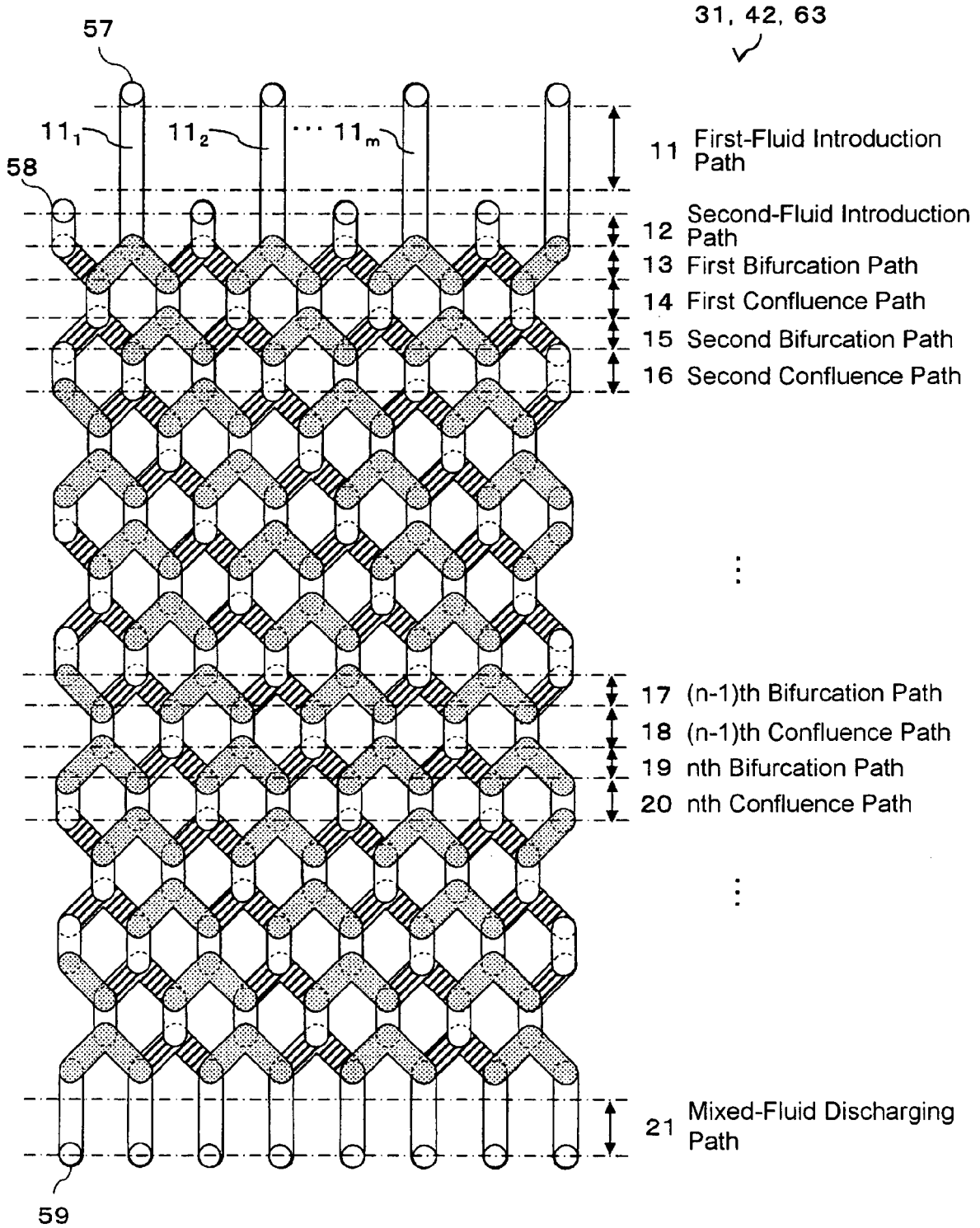

Fig. 7

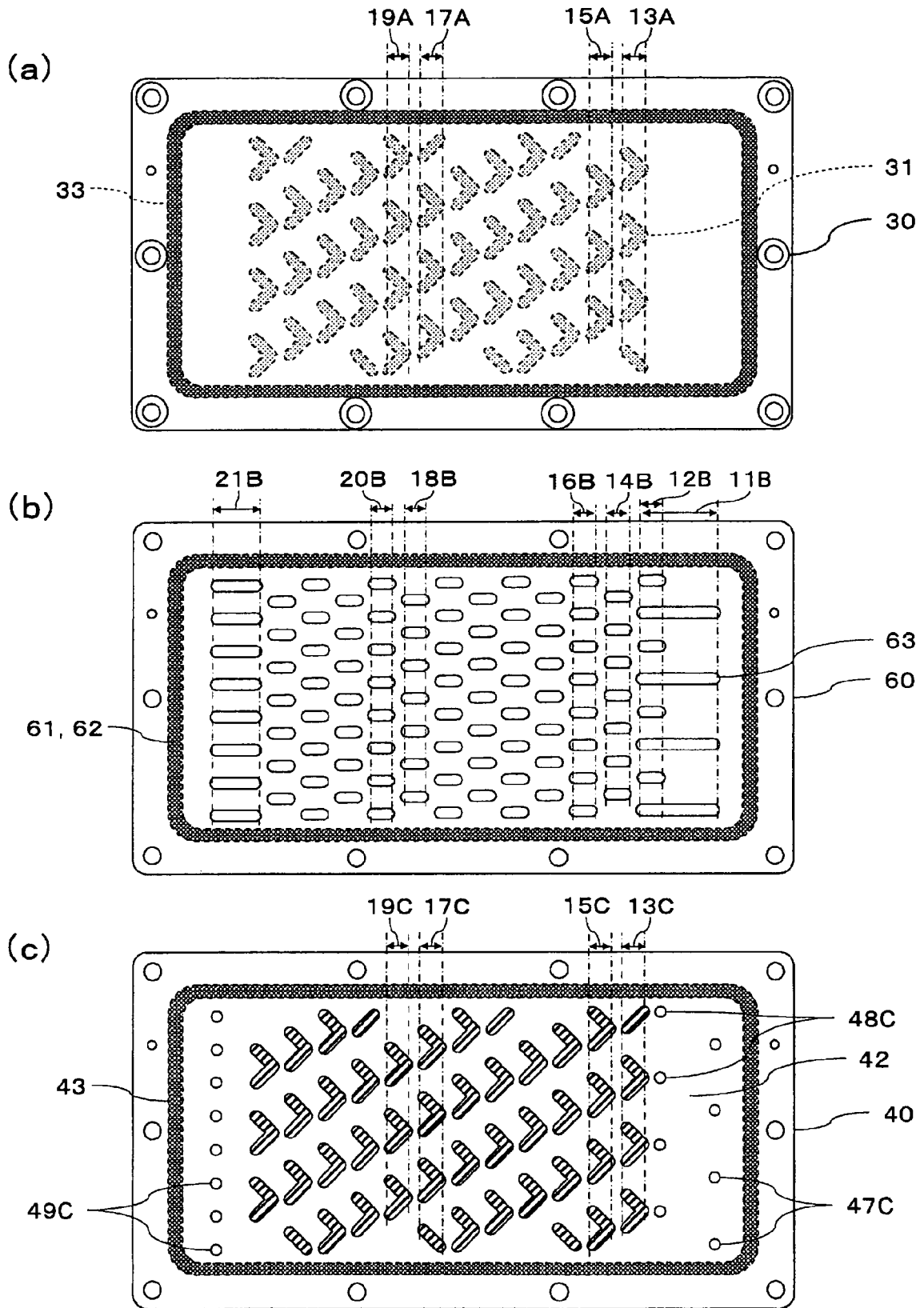
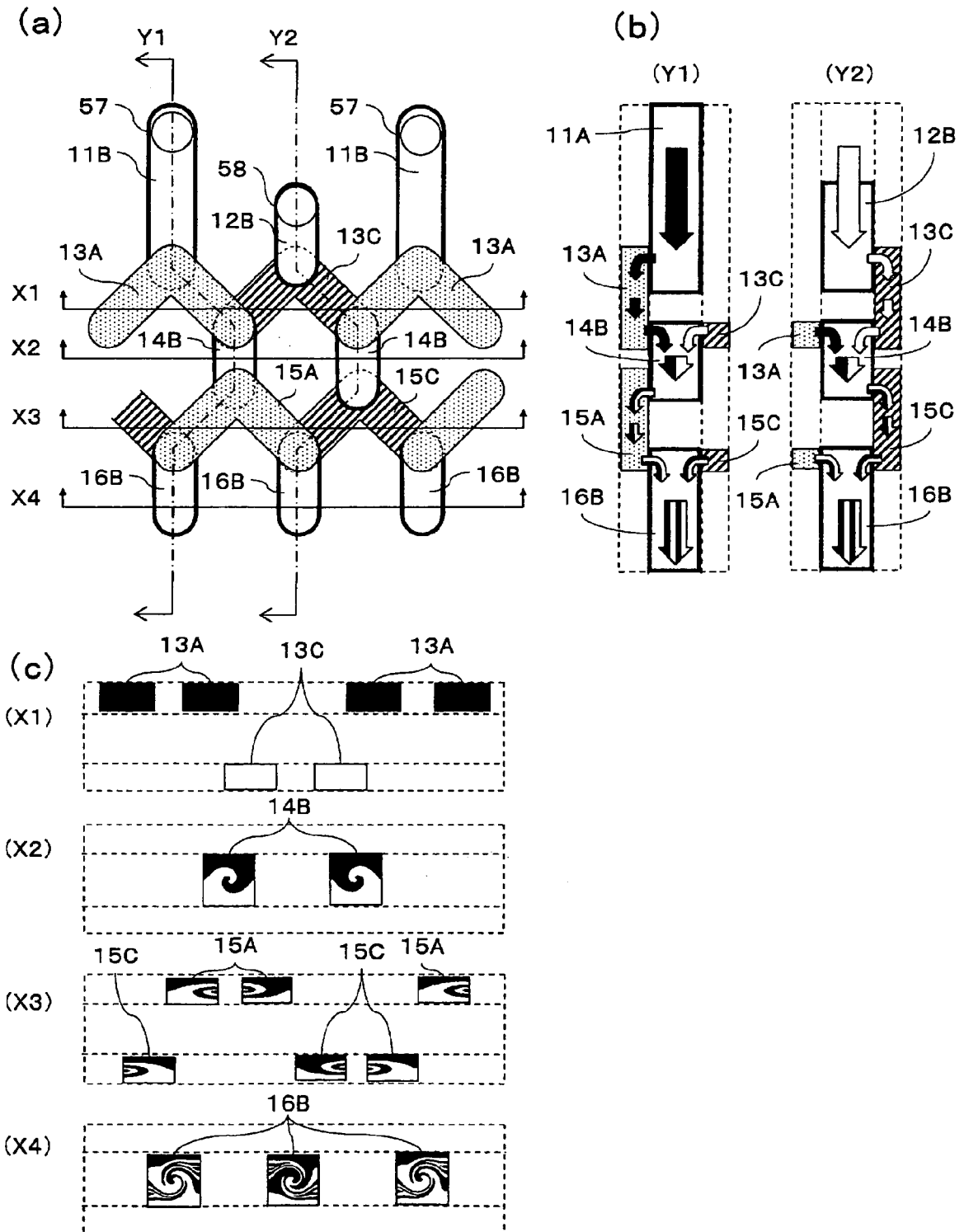

Fig. 8



**REFERENCES CITED IN THE DESCRIPTION**

*This list of references cited by the applicant is for the reader's convenience only. It does not form part of the European patent document. Even though great care has been taken in compiling the references, errors or omissions cannot be excluded and the EPO disclaims all liability in this regard.*

**Patent documents cited in the description**

- JP HEI11511689 B [0003]
- JP 2002346353 A [0005]