

(19) (KR)
(12) (B1)

(51) 。 Int. Cl. 7
H04N 5/335

(45) 2002 10 05
(11) 10 - 0354792
(24) 2002 09 17

(21) 10 - 2000 - 0016659
(22) 2000 03 30

(65) 2000 - 0063085
(43) 2000 10 25

(30) 11 - 88833 1999 03 30 (JP)
2000 - 49505 2000 02 25 (JP)

(73) 가 가 가 22 22

(72) 가 12 - 7 - 14
6 - 1 - 1 - 2 - - 401

(74)
:

(54)

(200) 1 (145) , (145) 가 1
1 1 (201, 202) . , (201) (200)
1 1 (203, 204) . , 1
2 2 가 1
, (201) 2 가 1
가 . , 1 2
가 .

1

1	1	,	,
2a 2f		,	
3		,	
4	2	,	
5a 5n		,	
6	3	,	
7a 7n		,	
8	4	,	
9a 9o		,	
10	5	,	
11a 11n		,	
12		,	
13		,	
14		,	
15		,	
16	14	15	,
17		,	
18		,	
19		,	
20a 20e		.	

가

() , () 가 ()

가

14 APS(Active Pixel Sensor) 가
 (101) (102) (103)
 (T) (103) (104)
 (V_{sig}) () (x) 가
 (V_{sig}) (103) (R)

가 (105) (V_D) 가 15 (111)
 15 CMD(Charge Modulation Device) 가 15 (x) (111)
 가 (111) 가 (V_{sig}) 가
 (111) (reset) 가 (x/R)

가 (R)

가

14 15 16
 16 (131) (resetting)
 (131) (106) (x) (107) (R)
 (131) (107) (V_{sig})

17 (2) 17
 2 (140) (131), 1 (141) 2 (142)
 (131) 1 (141) (143)
 (142) (144) (131) (145)
 (145) 가
 가 (131)
 가 (, FPN)가 (131)
 가 ((146) (147)) ((148)
 (149))

(145) (146) (148)
 (147) (V_{CP}) 가 (V_{CP})
 (131) (C1) 가
 (131) (s1)가 가
 (155) (148) (149) (155)
 (155) (160) (161) (155) (156)
 (164) (164) (169) (OS)

45) , 17 (2) (1
 (131) FPN , (1

(145) (155) (offset) (gain) , , FPN , , (156) , FPN

14) FPN , 18 가 (98 - 173997) . , 2 , 17 ((가 , 17 가 . 17 (145) (153) , (155)가 가 , 2 CDS(Correlated double sampli ng) (168)가 (164) (V_{ref}) . , (155) 가 (2) , (155) (H(j)) (160) (156) (164) (155) (153) (154) , (164) , (145) (155) (156) (145) 가 2 CDS (168) , (155) (156) 가 , (net) . FPN .

18 (145) (2) , , (147)가 (145) , (145) (148) 가 . , (145) (145) FPN

FPN , 19 (2)가 (FPN 98 - 145681) . 19 , (191,192) (190) (145) , (191,192) () (193,194) (V_{ref}) . (191) (155) (155) (160) (H(j), A₂(j)) , (164) , 2 CDS (168) .

20a 20e 19 가 , 가 (t) (193) , (190) (20a 20b) , (V₂) (20d) (V_f)가 , (V₃) (V_{ref})(20e)가 , (190),(193) , (V₂) V_f - V₁ - V₂ , (V₃) V_{ref} - V₂(20d 20e) . V₁가 (V₂) (190) , V₂가 (V₃) (193) . (191) :

(V_f - V₁ - V₂) - (V_{ref} - V₂) = V_f - V_{ref} - V₁.

20a 20c) (t₂) (194) (190) , (V₂) (V_d)가 , (190)가 V_d - V₁ , (V₃) , (V₃) (191) . (V₂) , :

$$(V_d - V_1) - (V_f - V_{ref} - V_1) = V_{ref} + (V_d - V_f)$$

(190) (V_f) (V_d) 가 (V_{ref}) 가 가 $V_d - V_f$,
 19 가 가 (155)
 가 (160)가
 (155) (V_{drop}) ,
 (193, 194) 가 FPM (191) (192),
 (145) FPN

FPN FPN
 FPN
 가 ;

가 가 가 가 1
 ; 가 가 가 1 ;

1 1 1 1 1
 2 1 1 2
 2 1

1 1 가 (CDS) 1 1
 가 1 CDS 1 CDS 1 1
 2 CDS , CDS
 FPN , FPN

10

10

가

가

MOS

가

, MOS

가

, MOS

CDS

가

1

1

1 CDS

1

, 1 CDS

2

1

1

2 CDS

CDS

FPN

, FPN

가 1

1

1

1

1

2

2

1

1 , 가 가 가
가

2 , 가 1 가
2 .

가 1 1 1 , ,

1 , 1 . , ,
2 , 1 2 ,

1 , 가 , 2 가 1
1 , 2 1 2 ,

1 1 2 2 1 2 ; 2

2 , 2

1 2 2 2 ,
FPN .

1 2 1 3
; 4 ; 1 1 2 2 2

3 1 4 2

1 2
3 4 2
FPN

1 2 1 1 가 2

1 , 2 가 1 .

가 가 2 , 가 1 2 1 ,
 , 1 1 1 2
 , 1 1 2 1 1 2

, FPN
 , FPN
 가
 가

(CORRECT)
 , FPN

1 1 1 2
 , FPN

(1)

1, 1 가 (145), (202)
 GND (201), 가 (200), 가 (201), V_{CP} (203),
 (202), 가 (201) (204)
 (203) GND (203) (204)
 (201) 1 (203) (204)
 1 PO, CO, SO (202)
 / PO (200), CO (203)
 / SO (203) / (203) (204)
 (145) (V_{in}) (201) (203) (204)
 04) (V_{out}) (203) (204)

2a 2f 2a
 2f
 2a 2f PO 1 1 (2b)
 1 (201) (200) (145)
 2c CO (V_{in}) (2a S1) t₁
 (2a S2) t₂ SO (2d)
 (201) (211) (V_m) (CO) (feed)
 through) V_{CP} 가 V_{CP} - V_{CP} 가 (2e) 가 ()
 201) V_S (211) (V_m) (V_S - V_{CP}) (V_{in}) (S₁) (S₂) ()

$$V_m(t_2) = V_{CP} - V_{CP} + V_S \quad (1)$$

(V_{out}) SO : V_{SH} 가 ,

$$V_{out}(t_2 + \Delta t) = V_{CP} - V_{CP} + kV_S - V_{SH} \quad (2)$$

(201)(Cc) 가 (204)
 k :

$$k = 1 - C_s/C_c \quad (3)$$

(Cc) (Cs) 10 (Cc)가 (Cs)
 (2) 2 t₄ (212)(Vout) (I_{d2}) V_{drp} ()
 2f) (t₄) (212)(V_{out}) 1 (Sa)

$$S_a(t_4 - t) = V_{cp} - V_{cp} + kV_S - V_{SH} - V_{drp} \quad (4)$$

$$V_{CP} - V_{CP} \text{ 가 } (201) \quad (211) \quad (202) \quad (200) \quad t_2 \quad t_3 \quad (2) \quad (1), \quad (2) \quad (4) \quad t_1 \quad \text{가} \quad (21) \quad V_{CP} \quad V_m \quad t_4 \quad I_{d1} \quad V_{drp} \quad \text{가} \quad (21)$$

$$V_{CP} - V_{CP} - V_{drp}$$

$$S_b \text{ 가 } t_4 \quad V_{SH} \quad (212) \quad 2 \quad S_b \text{ 가 } t_4 \quad V_{SH}$$

$$S_b(t_4 + t) = V_{CP} - V_{CP} - V_{drp} - V_{SH} \quad (5) \quad (2f) \quad (203) \quad V_{SH} \quad (2), \quad (4) \quad t_2 \quad \text{가} \quad (212) \quad (S_a) \quad (S_b) \quad (OS)$$

$$OS = S_a - S_b = kV_S$$

$$V_{SH} \text{ 가 } (V_{drp}), \quad \text{가} \quad \text{가} \quad (V_{CP}) \quad (V_S) \text{가}$$

$$t_3 \quad t_4 \quad (200, 202, 203) \quad (211) \quad (V_m) \quad (212) \quad (V_{out}) \quad \text{가} \quad (211, 212) \quad (2) \quad MOS \quad \text{가}$$

$$(212) \quad (V_{out}) \quad (V_{drp}) \quad (211) \quad (V_m) \quad c(x) \text{ 가 } t \quad (V(x)) \quad (V(x)) \quad I_d(x),$$

$$V(x) = I_d(x) \cdot t/c(x)$$

$$3 \quad MOS \quad (301), \quad MOS \quad (302) \quad (303) \quad a_1, \quad b_1, \quad S_J(X), \quad S_c(x) \text{ 가 } I_d(x) \quad C(x)$$

$$a_1, \quad b_1, \quad b_2 \text{ 가 } I_d(x) \quad C(x)$$

$$I_d(x) = a_1 S_J(x) \quad (8)$$

$$C(x) = b_1 S_J(x) + b_2 S_c(x) \quad (9)$$

$$= (b_1 + b_2 c_0) S_J(x) \quad (10)$$

$$c_0 = S_c(x)/S_J(x) \quad (11)$$

$$a_1, b_1, b_2, c_0$$

$$(7)$$

$V(x) =$
 , 가 , (211)(V_m) (212)(V_{out})
 212)(V_{out}) V_{drp} 가 , (dummy) (210)(V_m) 1 ()
 가 .
 , (7) (8) , (201) (Cc) , 가
 (201) (202) (203) (204) (204) (203)
 (204) (Cs) V_{drp} .
 , (200)가 (145) 1 1 CDS ,
 (145) (V_{in}) 2 2 CDS , , (200)가
 (204) 가 . 2 1 CDS , 가 ()
 204) 2 , 2 (204)
 , CDS , FPN .
 , FPN .
 (201) (204) 10 가 .
 , (201) 가 (204) , 가 .
 (202) MOS (203)
 MOS (211)(V_m) (212)(V_{out}) , MOS M
 OS CDS .
 (2)
 4 2 2 (140) . 4 , 2 17
 2 (145) . , 2 ,
 1 .
 4 (212) , (212) (203)
 (156) (164) (155) (155)
 (156) . (160) (161)
 (207) (203)
 , AND() 1 (205) SA (207)
 (SH) AND (205) (208) (207)
 (160) 2 (161) AND (205) , (H_(j))
 ND (205) . CDS (168) AND (164) , (s_j) A
 8) (169) . OS (169) , CDS (16
 (SH , SA , SW2 , CA , SW) , (c₂) , (s₂)
 (214) 가 .

4, (145) (200) (201) (200) (145)
 (200) (201) (203) 가
 (sw) (202) (202) (201)
 (V_{CP}) (CA)
 (203) (204) (203)
 (s_j) (204) (155)
 (156) (164) (164)
 CDS (168) (OS) (169)
 가 5a 5n 5a 5n
 1 (5b) (sw) (CA)
 (201) (200) (145) (5
 a V₁ S₁) t₁ (5c) (S_A)
 (5a V₁ S₂)
) t₂ (204)
 (sw) (5b), (200)
 (GND) t₃ (CA) (200)
 (V_{CP}) (201) 2
 (156) (155) (164) (H(j), H(j+1),
 H(j+2),...)(5e 5g) (145)
 t_j(j=4, 5,...) (203) (H(j), H(j+1), H(j+2),...)
) (H(j), H(j+1), H(j+2),...)(5i 5k) S_H (5H
) (155) (164) (V_{sr})
 (V_{CP}) 가
 (S_a) 2 (200) (V_{CP})(5l)가 5l, 2
 DS (S_b) 1 (S_a) 2 (S_b) C
 (OS) (168)(5m 5n) (c₂) (s₂)
 2 1 가
 V₁, V₂ V_{sr} (V_{in}), (211) (V_m) (212) (V_{out})
 (164) (4) (5) (164) 1 2 (S_a, S_b)가 2
 (164) CDS (168) (OS) (S_a) 2 (S_b)
 :

$$OS = S_a - S_b = kV_s$$

(6) (155) (V_{CP}),
 (V_{SH}) (V_{drp}) (V_s)
 , FPN
 (V_{drp}) (211) (V₂)
 (212) (V₃) 3
 (211)(V₂) (212)(V₃) V_{drp}
 (211)(V₂) (212)(V₃) 가
 (210)()

1 CDS (reset) 1
 (145) (155) 1
 CDS ()가 2
 2 CDS (155) (1
 64) CDS (168) CDS
 FPN
 가

(3)
 6 3
 (301) 2
 2 4 (304)가 (164) 6
 GND

6 (301) (160) (161) 가 ,
 (161) (301) (sw) (301)
 (161) (H(j), H(j+1),...) (sw) (301) (301)
 (156) (ha(j), ha(j+1), ...) (302)

7a 7n 7a 7n 2 5a 5n
 (Ha(j), Ha(j+1),...) (H(j), H(j+1),...) (sw)
 (Ha(j), Ha(j+1),...) , 7e 7g 가 (155)
 (164) (156) 1 ()
 2 () CDS

3 1 2
 2 (145) 7i 7k
 (203) 가
 가
 4 5a 5n 2 (156) 1
 (156) 2 (203)
 164) (203) (156) 1 2
 (156)가 (155) (156) (155)가 ()
 가 (155)가 가
 가 (156)가 , FPN

(156)가 3 1 () ,
 (203)가 1 (156)

(4)

8 (304) 4 (303) 3 ,

8 (304) (303) (164)
 GND (LG) (303)

9a 9o (303) (LG)가 가 9a 9o 2 5a 5n
 (Ha (j), Ha (j+1),...) (156) , (LG)가
 (303)가 (304) (164)
 가 (LG)가 (303) (Ha (j), Ha (j+1),...) (304)
 (164) 가

6 3 4 ,가 (155) 1 (1
 56) (164) (304) , 3
 , (155) (204)가 ,

4 (155) 4 8 9a 9o , (16
 (303)가 1 (304) (156) 가 (155)
 (155) 가 (155)
 (204)
 FPN

(5)

10 4 AND
 (401) 2 ,

10 , AND (401) (160) (161) 가
 (161) AND (401) , (SH) AND (401)
 , AND (401) (402) , AND (401)
 (161) (Ha (j), Ha (j+1),...) (SH) (402)
 (156) (Hb (j), Hb (j+1),...)

5a 5n (H_b(j), H_b(j+1),...) (H(j), H(j+1),...) (S_H)
 11a 11n 2
 11e 11g 가 , (155)
 (164) (203)가 2 () , 6
 8 , CDS , .

10 11a 11n , 5 가 ,
 (156) (203) 1 2
 (155) (156) (164)
 (203) , (156) (156)
 , FPN ,

12 13 4, 6, 8 10 CDS (168) 12 (V_{SR})가
 2 (21) 2 (22)
 CDS , (21) (C₂) (22)
 (S₂) (C₂) (S₂) 5m 5
 n . CDS (164) 1 (S_a) 2 (S_b)
 , , 13 (V_{SR}) 3
 4 CDS (31,32)가 (33)
 (31,32) (S₃, S₄)
 (S₃, S₄) 5m 5n C₂ C₃ S₂ (33)
 (31,32) 1 (S_a) 2 (S_b)
 (164) , 가
 12 13 CDS (S_a) (S_b)
 , FPN (OS) .

(207) 1 (S_H) ,
 (207) (156)가 2
 (200) (145) (203) .

1 1 1 1 CDS 가
 1 , 가
 2 1 1 2 CDS CDS

, 2
 CDS , , ,
 CDS , , ,

FPN

, FPN

10

가

가

MOS

, MOS

, MOS

CDS

가

DS

C

가

가

가

1

1

1

1

1

2

1

2

가

1

1

가

2

1

2

가

1

1

2

2 , 2 1 2 2

2 , , FPN , 1 2

1 2 3 4 가 .

4 1 가 , FPN

1 2 , 1 가 1 2

MOS , MOS MOS MOS MOS

가 MOS 가 MOS

CDS , MOS

1 2 , 1 1 1

1 2 1 2 , 가

1 , FPN , 가

가 , FPN 가 ,

1 1 1

1

5.

4 , 가 1 ;
 1 1 ,
 1 2 , 2 가 가
 2 , 가 1 가

6.

5 , 1 1 2 1 2 ;
 2 2 , 2

7.

5 , 1 2 1 ;
 3 ; 1 2 2 4
 ; 3 1 4 2

8.

4 , 1 1 가 2
 2 ,
 1 , 2 가 1

9.

4 , MOS ,

10.

5 , 1 1
 ,
 1 1 2

11.

10 , 가
 가

12.

5 , 1 1
 ,
 1 1 2

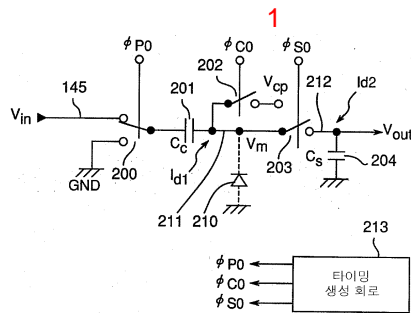

2a

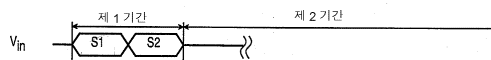

2b

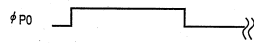

2c

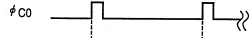

2d

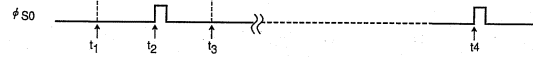

2e

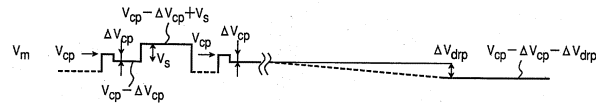

2f

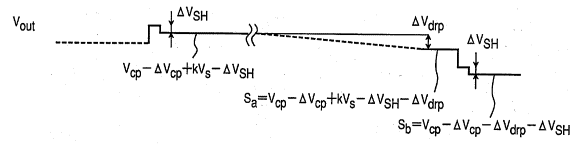

3

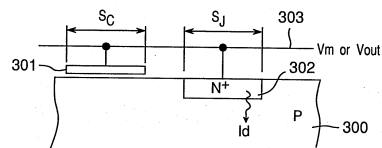

4

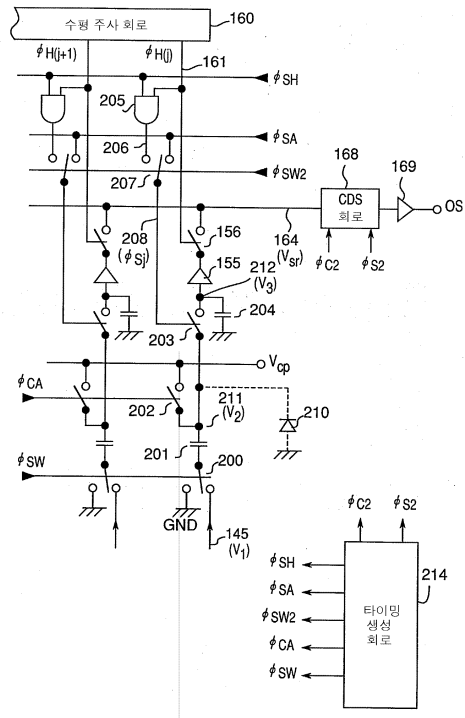

5a

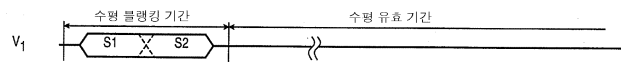

5b

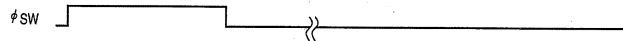

5c

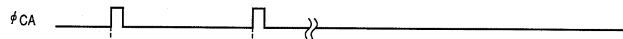

5d

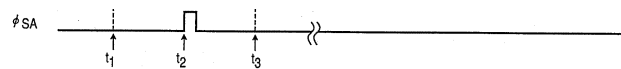

5e

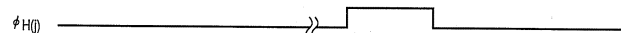

5f

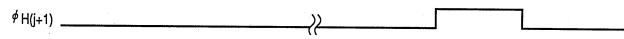

5g

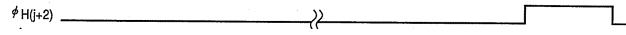

5h

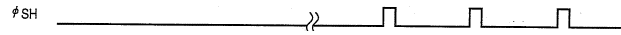

5i

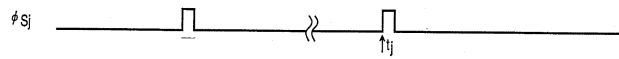

5j

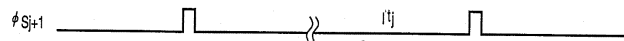

5k

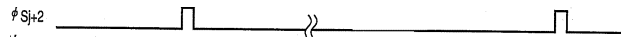

5l

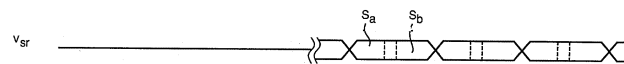

5m

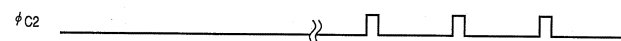

5n

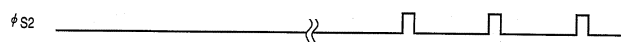

6

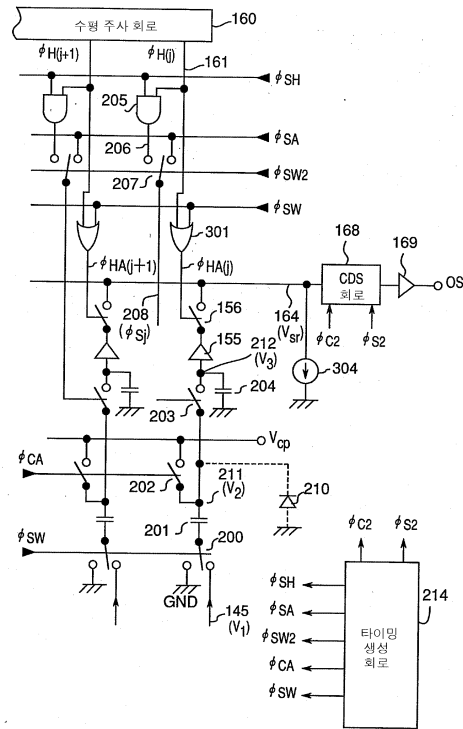

7a

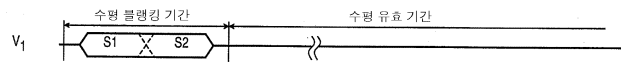

7b

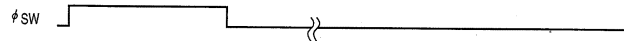

7c

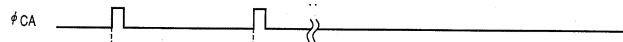

7d

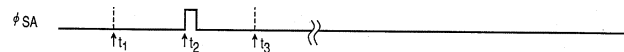

7e

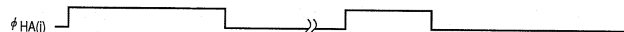

7f

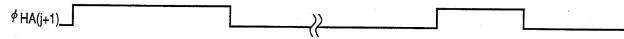

7g

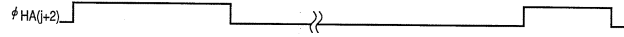

7h

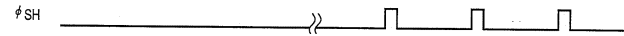

7i

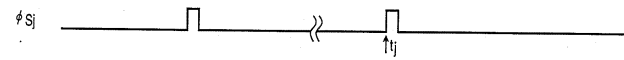

7j

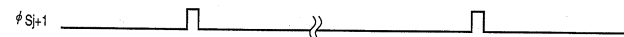

7k

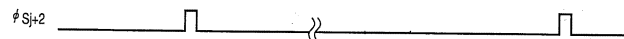

7l

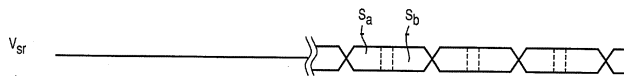

7m

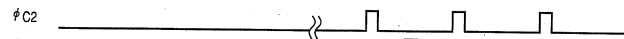

7n

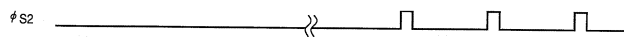

8

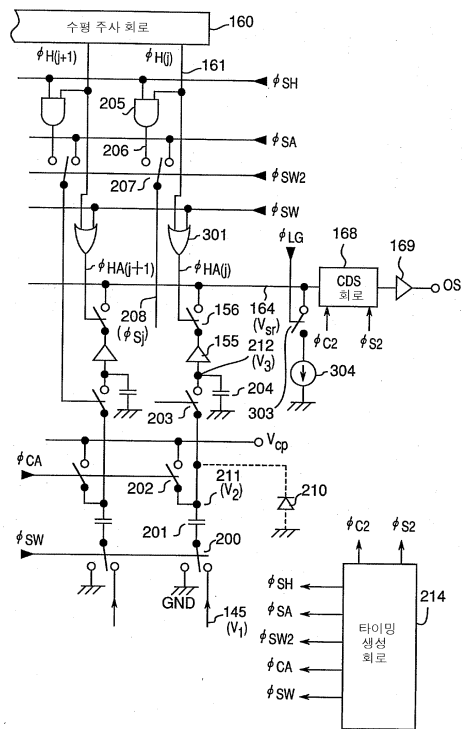

9a

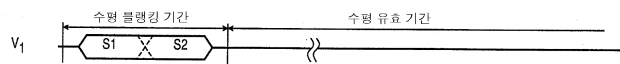

9b

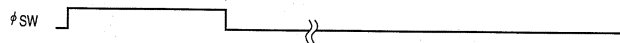

9c

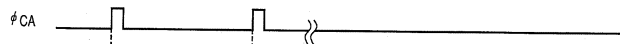

9d

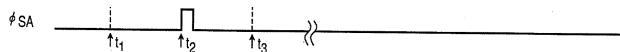

9e

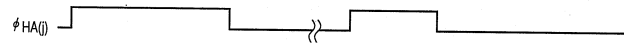

9f

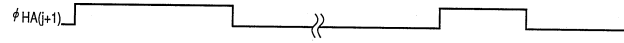

9g

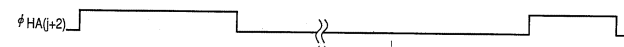

9h

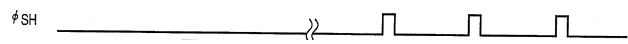

9i

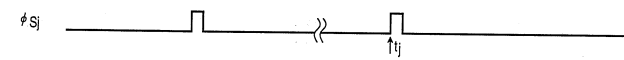

9j

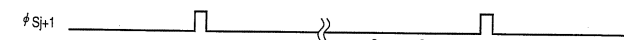

9k

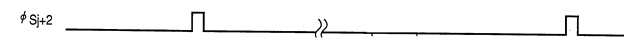

9l

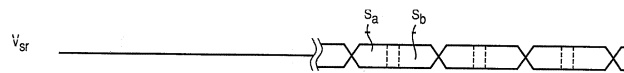

9m

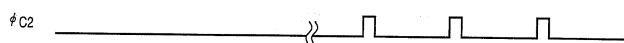

9n

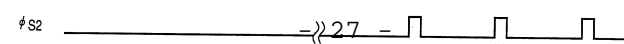

9o

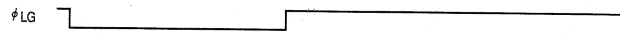

10

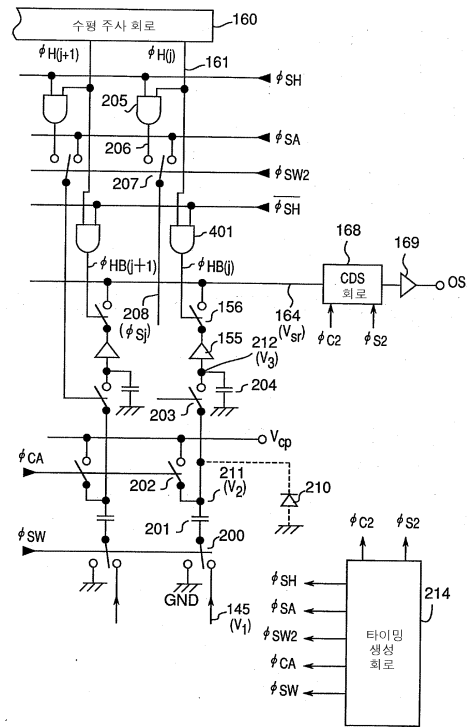

11a

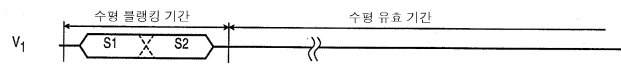

11b

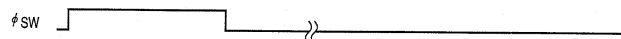

11c

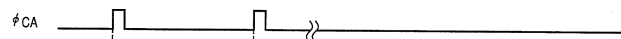

11d

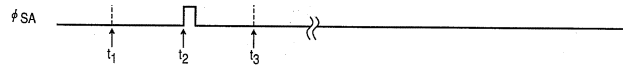

11e

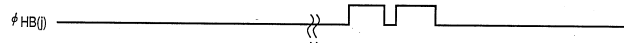

11f

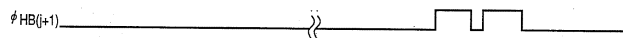

11g

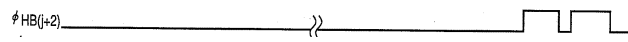

11h

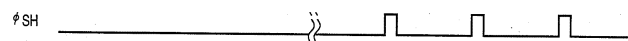

11i

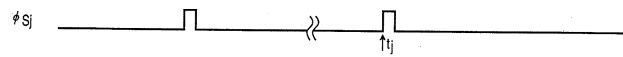

11j

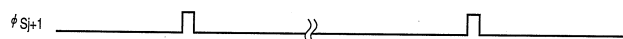

11k

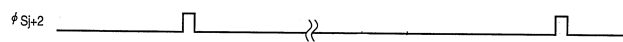

11l

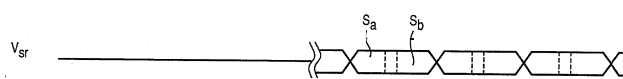

11m

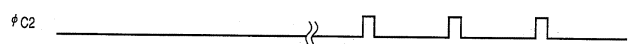

11n

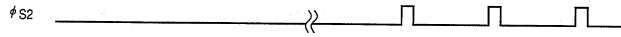

12

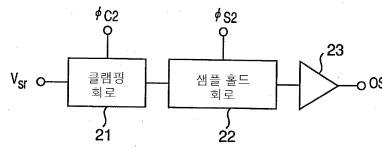

13

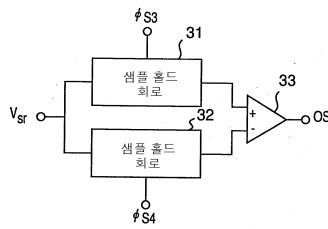

14

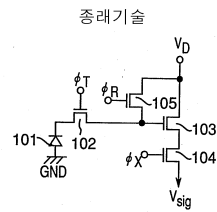

15

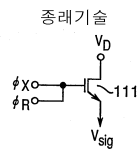

16

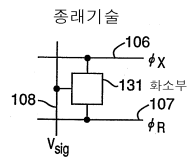

17

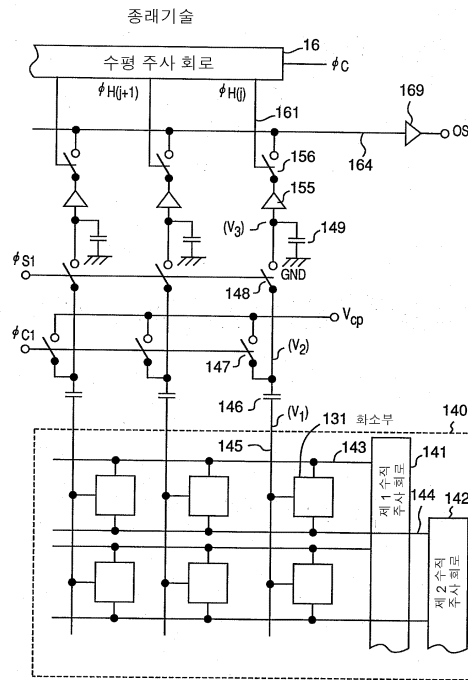

20b

종래기술

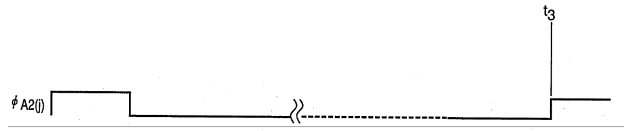

20c

종래기술

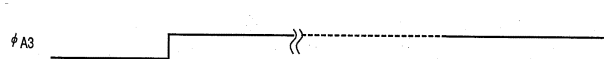

20d

종래기술

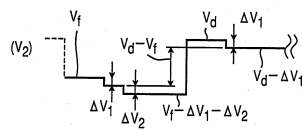

20e

종래기술

