

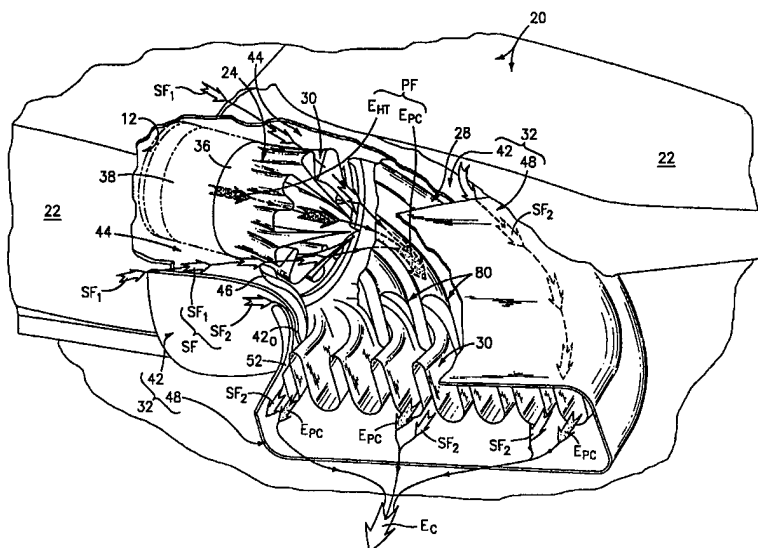

INTERNATIONAL APPLICATION PUBLISHED UNDER THE PATENT COOPERATION TREATY (PCT)

<p>(51) International Patent Classification⁶ : F02K 1/48, 1/38, 1/36, B64D 33/04</p>	<p>A1</p>	<p>(11) International Publication Number: WO 98/59162 (43) International Publication Date: 30 December 1998 (30.12.98)</p>
<p>(21) International Application Number: PCT/US98/11853 (22) International Filing Date: 19 June 1998 (19.06.98) (30) Priority Data: 08/881,191 24 June 1997 (24.06.97) US (71) Applicant: SIKORSKY AIRCRAFT CORPORATION [US/US]; Legal-IP Dept., M/S S316A, 6900 Main Street, P.O. Box 9729, Stratford, CT 06497-9129 (US). (72) Inventors: HAMMOND, Mark, H.; 37 Holly Hill Drive, Southington, CT 06489 (US). PRESZ, Walter, M., Jr.; 40 Grove Street, Wilbraham, MA 01095 (US). (74) Agent: COLLINS, Brian, A.; Sikorsky Aircraft Corporation, Legal-IP Dept., M/S S316A, 6900 Main Street, P.O. Box 9729, Stratford, CT 06497-9129 (US).</p>	<p>(81) Designated States: AU, CA, CN, IL, JP, KR, RU, TR, European patent (AT, BE, CH, CY, DE, DK, ES, FI, FR, GB, GR, IE, IT, LU, MC, NL, PT, SE). Published <i>With international search report.</i></p>	

(54) Title: MULTI-STAGE MIXER/EJECTOR FOR SUPPRESSING INFRARED RADIATION



(57) Abstract

A multi-stage mixer-ejector (20) having at least one exhaust nozzle (24 or 28) which includes inlet conduit adapted for receiving a primary flow PF of engine exhaust and a plurality of adjoined lobes (30) integrally formed in combination with the inlet conduit. The adjoined lobes (30) of the exhaust nozzle (24 or 28) are characterized by a first and second plurality of penetrating lobes (60, 62 or 70, 72) which are axially staggered with respect to each other and which are adapted for admixing low-temperature gaseous fluid with the high-temperature exhaust. In the preferred embodiment, at least one of the plurality of penetrating lobes (60 or 62, 70 or 72) extends into a core region (CR) of the exhaust nozzle (24 or 28) to effect thorough mixing of the low temperature gaseous fluid with the engine exhaust.

FOR THE PURPOSES OF INFORMATION ONLY

Codes used to identify States party to the PCT on the front pages of pamphlets publishing international applications under the PCT.

AL	Albania	ES	Spain	LS	Lesotho	SI	Slovenia
AM	Armenia	FI	Finland	LT	Lithuania	SK	Slovakia
AT	Austria	FR	France	LU	Luxembourg	SN	Senegal
AU	Australia	GA	Gabon	LV	Latvia	SZ	Swaziland
AZ	Azerbaijan	GB	United Kingdom	MC	Monaco	TD	Chad
BA	Bosnia and Herzegovina	GE	Georgia	MD	Republic of Moldova	TG	Togo
BB	Barbados	GH	Ghana	MG	Madagascar	TJ	Tajikistan
BE	Belgium	GN	Guinea	MK	The former Yugoslav Republic of Macedonia	TM	Turkmenistan
BF	Burkina Faso	GR	Greece			TR	Turkey
BG	Bulgaria	HU	Hungary	ML	Mali	TT	Trinidad and Tobago
BJ	Benin	IE	Ireland	MN	Mongolia	UA	Ukraine
BR	Brazil	IL	Israel	MR	Mauritania	UG	Uganda
BY	Belarus	IS	Iceland	MW	Malawi	US	United States of America
CA	Canada	IT	Italy	MX	Mexico	UZ	Uzbekistan
CF	Central African Republic	JP	Japan	NE	Niger	VN	Viet Nam
CG	Congo	KE	Kenya	NL	Netherlands	YU	Yugoslavia
CH	Switzerland	KG	Kyrgyzstan	NO	Norway	ZW	Zimbabwe
CI	Côte d'Ivoire	KP	Democratic People's Republic of Korea	NZ	New Zealand		
CM	Cameroon		Republic of Korea	PL	Poland		
CN	China	KR	Republic of Korea	PT	Portugal		
CU	Cuba	KZ	Kazakstan	RO	Romania		
CZ	Czech Republic	LC	Saint Lucia	RU	Russian Federation		
DE	Germany	LI	Liechtenstein	SD	Sudan		
DK	Denmark	LK	Sri Lanka	SE	Sweden		
EE	Estonia	LR	Liberia	SG	Singapore		

Multi-Stage Mixer/Ejector for Suppressing Infrared Radiation

Related Applications

This invention is related to co-pending, commonly-owned, U.S. Patent application entitled "Exhaust Nozzle for Suppressing Infrared Radiation" (Docket
5 No. S-5299).

Technical Field

This invention is directed to engine mixer/ejectors, and more particularly, to an multi-stage mixer/ejector operative to suppress the infrared signature radiated by the exhaust plume of an engine and/or the various hot metal components thereof.

10 Background Of The Invention

The exhaust plume of gas turbine engines, e.g., military aircraft engines, is a source of high infrared energy which may be used for targeting/tracking purposes by heat seeking missiles and/or various forms of infrared imaging systems, e.g., Night Vision Goggles (NVGs). With respect to the former, heat seeking missiles obtain directional
15 cues from the infrared energy, which directional cues are more precise depending upon the intensity, e.g., temperature, and total energy emitted by the exhaust plume. Regarding the latter, infrared imaging systems amplify the infrared energy by a factor of about 10,000 and may be used by hostile forces for early detection and/or targeting of surface-to-air/air-to-air missiles. Accordingly, it is highly desirable to reduce the infrared
20 emissions (also referred to as the IR signature) of such engines to a practical minimum to avoid detection, acquisition and/or tracking by enemy threats/forces.

Various infrared suppression systems have been designed and fielded which effect mixing of low temperature ambient air with the high temperature engine exhaust to reduce the IR signature radiated therefrom. Generally, it is the principle objectives of
25 such systems to: (a) reduce the infrared energy below a threshold level (e.g., a level capable of being sensed by the perceived threat), (b) maintain engine performance, and, (c) minimize the weight penalties associated therewith. Secondary objectives may include: (i) minimizing system or configuration complexity to reduce fabrication costs, (ii) minimizing the external aerodynamic drag produced by such IR suppressors,

and/or (iii) suppressing the acoustic emissions emanating therefrom which may also be a source of detection.

Hurley U.S. Patent 4,018,046 discloses an InfraRed (IR) suppressor for reducing the infrared radiation emitted from the exhaust plume and/or hot metal parts of a gas turbine engine. The IR suppressor includes an ejector vane assembly which is adapted for receiving a primary flow of engine exhaust and which is operative to entrain a first flow of cooling air into the primary exhaust flow. The primary flow of gases diffused from and entrained by the ejector vane assembly are fed into an arcuate duct which, due to its spatial position relative to the ejector vane assembly, produces an annular space for entraining a second flow of cooling air. The first and second flows are admixed with the primary exhaust flow to effect heat transfer therebetween and, consequently, to suppress the IR signature emitted from the exhaust plume. Additionally, the curved shape of the arcuate duct and/or the use of turning vanes disposed internally thereof, serve to prevent direct line-of-sight viewing into the IR suppressor. That is, the shape prevents viewing of radiant energy emitted by hot internal components such as from the ejector vane assembly or from the turbine section of the engine.

The ejector vane assembly described therein includes a plurality of V-shaped ejector vanes which entrain cooling air at a plurality of angularly spaced positions while additionally serving to introduce air toward the center of the engine exhaust. More specifically, each of the ejector vanes forms a V-shaped channel which is open to ambient air at one end thereof and is oriented to direct flow radially toward the core of the primary exhaust flow. The ejector vane assembly, furthermore, clusters the ejector vanes as close as practicable to the core of the primary exhaust flow and, furthermore, includes a means for adjusting the flow area through the ejector vanes to ameliorate engine performance. That is, the adjustment means effects collapse of each ejector vane so as to increase the flow area and reduce the back-pressure on the engine.

While the ejector vane assembly improves mixing, i.e., reduces the IR signature, by directing cooling air into a core region of the engine exhaust, it will be appreciated that the ejector vane assembly requires a large number of individual components. As such, the multiplicity of components, each being a potential source of repair and maintenance, reduces the overall reliability of the IR suppressor system. Furthermore,

while the adjustment means attempts to reduce flow restriction, the anticipated power loss produced by the ejector vane assembly is on the order of between 3% to 6%. In view of the fact that even small variations in efficiency, i.e., on the order of ½% to 1%, have significant impact on engine performance, such power loss may be viewed as intolerable
5 for certain aircraft and/or aircraft missions wherein maximum gross weight, flight speed, and range are critical design parameters. Moreover, while the IR suppressor employs a simple ejector principle to suppress infrared radiation, it will be appreciated that the manufacture of such IR suppressor, particularly the ejector vane assembly, is highly complex and requires multiple forming, machining, welding, and assembly operations.

10 Presz et al. U.S. Patents 4,835,961 and 4,830,315 describe nozzle configurations for mixing/pumping fluid. More specifically, the Presz '961 and '315 patents describe single and multi-stage mixer/ejector nozzles, respectively, each having a plurality of adjoined lobes formed at an outlet end thereof. The adjoined lobes define a primary flow trough for channeling a primary flow of high velocity/energy fluid, such as the exhaust of
15 a gas turbine engine, and a secondary flow trough for channeling a secondary flow of low velocity/energy fluid such as ambient air. The primary and secondary flow troughs are alternately disposed about the periphery of the nozzle such that thin sheets of high energy fluid flow from the trough outlets, transfer kinetic energy to the low energy fluid, and entrain the secondary flow into the primary flow. Aside from simple viscous or shear
20 mixing, the adjoined lobes produce axial vortices which rapidly admix the primary and secondary flows. As such, the adjoined lobes described in the Presz '961 and '315 patents are known to have utility on aircraft engines to both increase thrust and for suppressing the thermal energy radiated from the engine.

25 While the adjoined lobes serve to rapidly admix the primary and secondary flows to reduce the IR signature, the nozzle configurations disclosed therein fail to fully mix the flows, particularly in the core region of the primary exhaust flow. That is, in all of the embodiments described therein, the lobes entrain the secondary cooling flow into a perimeter region of the flow such that a central core or band of high temperature exhaust remains as the flow exits the nozzle. While the core of high temperature flow will
30 eventually admix downstream, it will be appreciated that the degree of IR suppression is compromised until such energy is diffused.

A need, therefore exists, for providing a multi-stage mixer/ejector which maintains or improves engine performance, rapidly and thoroughly diffuses the IR energy emitted/radiated from a gas turbine engine, and facilitates fabrication via conventional, low-cost, manufacturing methods.

5 **Summary of the Invention**

It is an object of the present invention to provide a multi-stage mixer/ejector for suppressing the InfraRed (IR) radiation emitted by the exhaust plume and/or the hot metal components of an engine while maintaining or improving engine performance.

10 It is another object of the present invention to provide such a multi-stage mixer/ejector which, at each stage of the mixer/ejector, is adapted for entraining a secondary flow of low temperature gaseous fluid into a core region of the primary engine exhaust.

15 It is yet another object of the present invention to provide such a multi-stage mixer/ejector which is readily fabricated by conventional, low-cost, manufacturing methods.

It is yet a further object of the present invention to provide such a multi-stage mixer/ejector wherein the geometry thereof prevents direct line-of-sight viewing into the mixer/ejector.

20 These and other objects of the present invention are achieved by a multi-stage mixer/ejector having at least one exhaust nozzle which includes inlet conduit adapted for receiving a primary flow PF of engine exhaust and a plurality of adjoined lobes integrally formed in combination with the inlet conduit. The adjoined lobes of the exhaust nozzle are characterized by a first and second plurality of penetrating lobes which are axially staggered with respect to each other and which are adapted for admixing low-temperature
25 gaseous fluid with the high-temperature exhaust. In the preferred embodiment, at least one of the plurality of penetrating lobes extends into a core region of the exhaust nozzle to effect thorough mixing of the low temperature gaseous fluid with the engine exhaust.

Brief Description Of The Drawings

A more complete understanding of the present invention and the attendant features and advantages thereof may be had by reference to the following detailed description of the invention when considered in conjunction with the following drawings wherein:

Fig. 1 is a profile view of a helicopter illustrating an exemplary installation of a multi-stage mixer/ejector according to the present invention;

Fig. 2 is a partially broken-away perspective view of a multi-stage mixer/ejector disposed in combination with the aft end of a gas turbine engine, which multi-stage mixer/ejector includes tandemly-arranged first and second stage exhaust nozzles;

Fig. 3a is an isolated perspective view of the first stage exhaust nozzle having a plurality of adjoined lobes forming an outlet end of the exhaust nozzle, wherein the adjoined lobes further include a first and second plurality of penetrating lobes which are axially staggered relative to each other and wherein at least one of the plurality of penetrating lobes extends into a core region of the exhaust nozzle;

Fig. 3b is an end view of the first stage exhaust nozzle wherein the first and second plurality of penetrating lobes alternate about the periphery of the first stage exhaust nozzle;

Fig. 3c is a cross-sectional view taken substantially along line 3c - 3c of Fig. 3b wherein the first and second plurality of penetrating lobes each terminate at a distinct exit plane;

Fig. 4a is an isolated perspective view of the second stage exhaust nozzle having a plurality of adjoined lobes forming an outlet end of the exhaust nozzle, wherein the adjoined lobes further include a first and second plurality of penetrating lobes which are axially staggered relative to each other, and wherein at least one of the plurality of penetrating lobes extends into a core region of the exhaust nozzle;

Fig. 4b is an end view of the second stage exhaust nozzle wherein the first and second plurality of penetrating lobes are inset with respect to each other;

Fig. 4c is a side view taken along line 4c - 4c of Fig. 4b wherein the first and second plurality of penetrating lobes each terminate at a distinct exit plane;

Figs. 5a and 5b compare a baseline, non-staggered, inset nozzle to the staggered, inset, second stage exhaust nozzle according to the present invention for contrasting the flow areas defined by each nozzle;

Fig. 6a depicts an alternate embodiment of the multi-stage mixer/ejector wherein the first stage exhaust nozzle has an unequal number of perimeter and core penetrating lobes;

Fig. 6b depicts an alternate embodiment of the multi-stage mixer/ejector wherein the outlet end of the second stage exhaust nozzle defines a substantially elliptical geometric profile;

Fig. 6c depicts an alternate embodiment of the multi-stage mixer/ejector wherein the outlet end of the second stage exhaust nozzle defines a substantially hour-glass shape;

Fig. 6d depicts an alternate embodiment of the multi-stage mixer/ejector wherein the adjoined lobes of the first stage exhaust nozzle include a first, second and third plurality of penetrating lobes and wherein each plurality of penetrating lobes terminate at a distinct exit plane;

Fig. 6e depicts an alternate embodiment of the multi-stage mixer/ejector wherein an end face of the second stage exhaust nozzle is inclined to effect a gradual stagger of the penetrating lobes in an axial direction.

Best Mode For Carrying Out The Invention

The exemplary embodiments of the present invention will be described in the context of a helicopter gas turbine engine, though, it will be appreciated that the teachings described herein are applicable to any turbo-shaft engine wherein the maximization of shaft horsepower is a principle design objective. This application is to be distinguished from other engine designs, such as turbo-jet or turbo-fan engines, wherein the maximization of thrust, rather than shaft horsepower, is a key design objective.. Furthermore, while the present invention describes such a multi-stage mixer/ejector wherein one such exhaust nozzle employs a bend therein for preventing direct line-of-sight viewing into the gas turbine section of the engine, the teachings are also applicable to in-line ejector configurations.

Referring now to the drawings wherein like reference characters identify corresponding or similar elements throughout the several views, Fig. 1 shows a

helicopter 10 having one or more gas turbine engines 12 for driving a main and tail rotor, 14 and 16, respectively. A multi-stage mixer/ejector 20 according to the present invention is disposed in combination with the aft end of each gas turbine engine 12 and is operative to suppress the InfraRed (IR) signature radiated from the high-temperature exhaust of the respective engine 12. In the context used herein, "to suppress" means that the IR signature emanating from the gas turbine engine 12 is reduced below some predetermined threshold value which is indicative of the acquisition, tracking and/or targeting capability of a particular IR threat.

In Fig. 2, a perspective view of the multi-stage mixer/ejector 20 is shown in combination with the engine 12 and in position relative to the helicopter fuselage 22. Before discussing each element and/or feature of the multi-stage mixer/ejector 20 in detail, a brief overview of the major components and the operation of each will be provided. The multi-stage mixer/ejector 20 comprises tandemly-arranged first and second stage exhaust nozzles 24 and 28, respectively, each having a plurality of adjoined lobes 30, and a shroud means 32 for enveloping the adjoined lobes 30 of each exhaust nozzle. Each of the first and second stage exhaust nozzles 24, 28 is adapted for receiving a primary flow PF of engine exhaust, for diffusing the primary flow PF through the respective adjoined lobes 30, and for entraining a secondary flow SF of low temperature gaseous fluid, e.g., ambient air, into the primary flow PF. More specifically, the effluent primary flow PF entrains the secondary flow SF through flow passages (discussed below) defined by the shroud means 32. Accordingly, in the described embodiment, the multi-stage mixer/ejector 20 entrains two secondary flows SF, i.e., a first flow SF₁ directed toward the exit plane of the first stage exhaust nozzle 24, and a second flow SF₂ directed toward the exit plane of the second stage exhaust nozzle 28. The fluid dynamics principle for entraining such secondary flows SF₁, SF₂ is well-known in the art and is often referred to as a "venturi effect".

In the described embodiment, an inlet conduit 36 of the first stage exhaust nozzle 24 is disposed in combination with the exhaust casing 38 of the engine 12 for receiving the primary upstream flow PF of high temperature engine exhaust E_{HT}. The primary upstream flow PF of high temperature engine exhaust E_{HT} is diffused and admixed with the secondary flow SF₁ via the adjoined lobes 30. The shroud means 32

includes a first stage shroud 42 which generally complements the shape of the first stage exhaust nozzle 24 and which defines a generally annular passage 44 for channeling the respective secondary flow SF_1 . The adjoined lobes 30 of the first stage exhaust nozzle 24 incorporate several inventive features which serve to ameliorate the fluid dynamics/mixing of the primary and secondary flows PF, SF_1 . While these and other features of the first stage exhaust nozzle 24 will be discussed in greater detail below, suffice it to say at this point in the description, that the primary and secondary flows PF, SF_1 admix to produce a primary midstream flow PF of partially-cooled exhaust E_{PC} .

An inlet conduit 46 of the second stage exhaust nozzle 28 is disposed proximal to the adjoined lobes 30 of the first stage nozzle 24 and is adapted to receive the primary midstream flow PF of partially-cooled exhaust E_{PC} . In the described embodiment, the inlet conduit 46 defines a substantially circular opening of sufficient size to envelope the first stage adjoined lobes 30 and, as such, functions in combination with the shroud means 32 to entrain the secondary flow SF_1 . The resultant partially cooled exhaust E_{PC} is diffused and admixed with the secondary flow SF_2 by the adjoined lobes 30 of the second stage nozzle 28. The shroud means 32 includes a second stage shroud 48 which generally complements the shape of the second stage adjoined lobes 30 and which defines a generally tubular passage 52 for channeling the respective secondary flow SF_2 . Furthermore, in the described embodiment, the second stage shroud 48 envelopes the outlet end 42_o of the first stage shroud 42 such that the shrouds 42, 48, in combination, provide a continuum of structure for occluding the underlying exhaust nozzles 24, 28.

The adjoined lobes 30 of the second stage exhaust nozzle 28 incorporate various inventive teachings which ameliorate the fluid dynamics/mixing of the primary and secondary flows PF, SF_2 and produce a primary downstream flow of cooled/suppressed engine exhaust E_C . Furthermore, the second stage exhaust nozzle 28 and the adjoined lobes 30 thereof redirect the primary flow PF to prevent impingement thereof on other fuselage structure. Lastly, the second stage exhaust nozzle 28 and the configuration of the adjoined lobes 30 thereof prevent direct line-of-sight viewing into the gas turbine section of the engine 12. These and other features of the second stage exhaust nozzle 28 will be discussed in subsequent paragraphs.

First Stage Exhaust Nozzle

In Figs. 3a - 3c, various views of the first stage exhaust nozzle 24 are depicted to illustrate the inventive features of the adjoined lobes 30. As shown, the adjoined lobes 30 are integrally formed in combination with the inlet conduit 36 and define an outlet end of the first stage exhaust nozzle 24. In the two-dimensional plane of Fig. 3b, each lobe 30 is defined as extending from peak-to-peak, i.e., between reference points P_K , and is substantially radial with respect to a line 56 projecting from a longitudinal axis 24_A of the exhaust nozzle 24. In the context used herein, "substantially radial" means that the centerline 30_{CL} of each lobe 30 is within about 5 degrees of the angular orientation of such radial line 56. Moreover, each of the adjoined lobes 30 forms an external flow trough 30_{EFT} adapted for channeling the secondary flow SF of low temperature gaseous fluid, while adjacent lobes 30 form an internal flow trough 30_{IFT} adapted for channeling and diffusing the primary flow PF of high temperature exhaust.

In the exemplary embodiment, the adjoined lobes 30 comprise a first and second plurality of penetrating lobes, 60 and 62, respectively, wherein the first and second plurality of penetrating lobes 60, 62 are axially staggered with respect to each other and wherein at least one of the plurality, 60 or 62, is adapted to extend into a "core region" of the exhaust nozzle 24. Before discussing the functional significance of such lobe configuration it is useful to spatially define the core region as well as to define certain structural and geometric features of the penetrating lobes 60, 62.

The core region of the first stage exhaust nozzle 24 may be spatially defined by a three-dimensional reference boundary which is, in turn, defined by the external flow troughs 30_{EFT} of the first plurality of penetrating lobes 60. More specifically, the locus of end points 60_E thereof (see Figs. 3b and 3c) define a two-dimensional reference circle or boundary R_{B2D} . By extending the two-dimensional boundary R_{B2D} axially in three-dimensional space, a three dimensional reference boundary R_{B3D} (Fig. 3c) is defined which spatially defines the core region CR of the exhaust nozzle 24. Hereinafter, the core region CR of the exhaust nozzle 24 shall also mean the core region of the primary flow PF of engine exhaust.

In the described embodiment, the second plurality of penetrating lobes 62 extends into the core region CR so as to direct the secondary flow SF of low temperature gaseous

fluid deeply into the primary flow PF of engine exhaust (see Fig. 3c). In the preferred embodiment, the end points 62_E of the second plurality of penetrating lobes 62 are proximal to the longitudinal axis 24_A of the exhaust nozzle 24. Furthermore, the first and second plurality of penetrating lobes 60, 62 are alternately disposed about the periphery of the exhaust nozzle 24 and are equiangularly spaced relative to the longitudinal axis 24_A .

Additionally, the first and second plurality of penetrating lobes 60, 62 are axially staggered with respect to each other (see Fig. 3c) so as to define at least two exit planes P_{60} , P_{62} for diffusing the secondary flow SF. Furthermore, each external flow trough 30_{EFT} of the penetrating lobes 60, 62, defines a smooth curve 66 along its axial length, which curve 66 is directed inwardly toward the longitudinal axis 24_A of the exhaust nozzle 24. Preferably, the slope of the curve 66 is less than about 30 degrees relative to the longitudinal axis 24_A to avoid flow separation, i.e., separation of the secondary flow SF from the surface of the respective external flow trough 30_{EFT} . Finally, each of the second plurality of penetrating lobes 62 is tapered in radial height and width along its length.

The adjoined lobes 30 of the first stage exhaust nozzle 24 produce axial vortices V which admix the primary and secondary flows PF, SF to effect rapid convective heat transfer therebetween. This mixing principle is generally known in the art and more fully described in Presz, Jr. Et al. U.S. Patent 4,835,961. Improvements thereto, which are the subject of the present invention, relate to modifying the adjoined lobes 30 to axially stagger the penetrating lobes 60, 62, and to cause at least one plurality of lobes 60 or 62 to penetrate into the core region of the primary flow PF. More specifically, the first plurality of penetrating lobes 60 channel the secondary flow SF into a perimeter region PR of the exhaust nozzle 24 (Figs. 3b and 3c) while the second plurality of penetrating lobes 62 channel the secondary flow SF deeply into the core region CR of the exhaust nozzle 24. As such, the secondary flow SF of low temperature gaseous fluid is channeled into substantially all of the primary flow PF to improve the efficacy of the heat transfer and the degree of IR suppression.

Furthermore, the second plurality or "core" penetrating lobes 62 project axially downstream of the first plurality or "perimeter" penetrating lobes 60 and curve inwardly

toward the longitudinal axis 24_A . As such, the penetrating lobes 60, 62 are axially staggered so as to avoid convergence thereof at the same axial station. Such staggering has the effect of reducing back-pressure by geometrically increasing the flow area at a particular axial station. That is, at the exit plane P_{60} of the perimeter penetrating lobes 60, the entire core region CR is open for unrestricted flow of engine exhaust, while at exit plane P_{62} of the core penetrating lobes 62, the perimeter region PR is essentially open for the flow of engine exhaust.

This may be more fully appreciated by comparing the ejector vane assembly discussed in the Background of the Invention with the penetrating lobes 60, 62 of the present invention. With respect thereto, the ejector vane assembly of the prior art is configured such that each ejector vane directs flow into a core region of the engine exhaust and all the ejector vanes converge at the same axial station. As such, the back-pressure produced by the clustered arrangement of ejector vanes results in significant engine power loss. In contrast, the penetrating lobes 60, 62, of the present invention direct flow into the core region while staggering the exit planes P_{60} , P_{62} to facilitate unrestricted flow of engine exhaust.

Second Stage Exhaust Nozzle

In Figs. 4a - 4c, various views of the second stage exhaust nozzle 28 are depicted to illustrate the inventive features of the adjoined lobes 30. As shown, the adjoined lobes 30 are integrally formed in combination with the inlet conduit 46 and define an outlet end of the second stage exhaust nozzle 28. In the two-dimensional plane of Fig. 4b, each lobe 30 is defined as extending from peak-to-peak, i.e., between reference points P_K , and is substantially perpendicular with respect to a line 68 projecting from a midplane P_M of the exhaust nozzle 28. In the context used herein "substantially perpendicular" means that the centerline 30_{CL} of each lobe 30 is within about 5 degrees of the angular orientation of such perpendicular line 76. Moreover, each of the adjoined lobes 30 forms an external flow trough 30_{EFT} adapted for channeling the secondary flow SF of low temperature gaseous fluid (best seen in Fig. 4a), while two adjacent lobes 30 form an internal flow trough 30_{IFT} adapted for channeling and diffusing the primary flow PF of partially-cooled exhaust.

In the exemplary embodiment, the adjoined lobes 30 comprise a first and second plurality of penetrating lobes, 70 and 72, respectively, wherein the first and second plurality of penetrating lobes 70, 72 are axially staggered with respect to each other, and wherein at least one of the plurality, 70 or 72, are adapted to extend into a "core region" of the exhaust nozzle 28. In the described embodiment, the core region of the second stage exhaust nozzle 28 may be spatially defined by a three-dimensional reference boundary which is, in turn, defined by the external flow troughs 30_{EFT} of the first plurality of penetrating lobes 70. More specifically, the locus of end points 70_E thereof (see Fig. 4b) define a first two-dimensional reference curve R_1 which, in combination with a second two dimensional reference curve R_2 reflectively disposed about the midplane P_M , defines a two-dimensional reference boundary R_{B2D} . By extending the two-dimensional boundary R_{B2D} axially in three-dimensional space, a three-dimensional reference boundary R_{B3D} is defined (see Fig. 4c) which spatially defines the core region CR of the exhaust nozzle 28. Hereinafter the core region CR of the exhaust nozzle 28 shall also mean the core region of the primary flow of engine exhaust.

Before discussing the functional significance of the lobe configuration and/or the lobe configuration as it relates to the core region of the engine exhaust, it is useful to define certain structural and geometric features of the penetrating lobes 70, 72. More specifically, in the described embodiment, the second plurality of penetrating lobes 72 extend into the core region CR so as to direct the secondary flow SF of low temperature gaseous fluid into the primary flow PF of engine exhaust. In the preferred embodiment, the second plurality of penetrating lobes 72 fully penetrate or traverse the core region CR so as to divide the primary exhaust flow PF into a plurality of discrete flow segments. Furthermore, the first and second plurality of penetrating lobes 70, 72 are axially staggered with respect to each other (see Fig. 3c) so as to define at least two exit planes P_{70} , P_{72} for diffusing the secondary flow SF. Moreover, in the preferred embodiment, the second plurality of penetrating lobes 72 are "inset" with respect to the first plurality of penetrating lobes 70 at an axial location corresponding to the exit plane P_{70} and, more preferably, are inset at an axial location 74 inboard of the exit plane P_{70} . In the context used herein "inset" means that each external flow trough 30_{EFT} of the second plurality of penetrating lobes 72 is aligned with an internal flow trough 30_{IFT} of the first plurality of

penetrating lobes 70, and crosses the midplane P_M of the exhaust nozzle 28. Also, in the preferred embodiment, the penetrating lobes 70, 72 define a substantially 90 degree bend, which in combination with the inset configuration thereof, define a plurality of turning vanes 80 (see Fig. 4a) for redirecting the primary flow PF.

5 The adjoined lobes 30 of the second stage exhaust nozzle 28 produce axial vortices V (Figs. 4a and 4c) which admix the primary and secondary flows PF, SF to effect rapid convective heat transfer therebetween. In addition to this known mixing principle, the inset configuration of the adjoined lobes 30 causes each plurality of penetrating lobes 70, 72 to cross the midplane P_M , thereby channeling the secondary flow
10 SF into the core region CR of the exhaust nozzle 28. As such, the secondary flow SF of low temperature gaseous fluid is channeled into substantially all of the primary flow PF to improve the efficacy of the heat transfer and the degree of IR suppression.

In addition, the inset configuration of the penetrating lobes 70, 72 facilitates the formation of turning vanes 80 (Fig. 4a) for directing/redirecting the primary exhaust flow
15 PF. That is, the upper and lower nozzle walls collapse inwardly to form the external flow troughs 30_{EFT} while, concomitantly, forming an integral turning duct or vane 80. While the turning vanes 80 serve to direct flow outwardly of the fuselage 22, an equally important function relates to the occlusion of internal components and/or upstream flow from direct-line-of-sight view. That is, the inset configuration of the penetrating
20 lobes 70, 72 in combination with the 90 degree bend of the exhaust nozzle prevents direct line-of-sight viewing into the interior of the second stage exhaust nozzle 28. As such, "hot spots" disposed internally of the exhaust nozzle 28, such as from the gas turbine section of the engine, cannot radiate outwardly so as to become viewable by a heat seeking threat.

25 Furthermore, the second plurality of penetrating lobes 72 project axially downstream of the first plurality of penetrating lobes 70 for providing both engine performance and IR suppression benefits. More specifically, such staggering has the effect of reducing back-pressure by (i) producing two in-line ejector pumps in series, and (ii) geometrically increasing the flow area at a particular axial station. With regard to the
30 former, the first plurality of penetrating lobes 70 are adapted to entrain the secondary flow SF at exit plane P_{70} , and the second plurality of penetrating lobes 72 are adapted to

entrain the secondary flow SF at exit plane P_{72} . As such, the staggered arrangement produces an additive or compounding effect with respect to pumping efficacy. Accordingly, more cooling air is entrained for suppressing the IR signature of the primary exhaust flow PF, and engine back-pressure is reduced by gains in fluid dynamic pumping. With respect to the latter, the geometrical effect on engine performance may be more fully understood by referring to Figs. 5a and 5b wherein the flow area of the second stage exhaust nozzle 28 is compared to a Non-Staggered Inset (NSI) lobed nozzle 86. It should be appreciated that such NSI lobed nozzle 86 is not known in the art but is used herein as a baseline for comparison.

10 In Fig. 5a, the exit plane of the NSI lobed nozzle 86 is overlaid in combination with a section view of the second stage exhaust nozzle 28 at exit plane P_{70} . The profile of the NSI nozzle 86 is shown in dashed lines in areas where the NSI nozzle 86 structurally differs from the second stage exhaust nozzle 28 and in solid lines in areas where the nozzles are essentially identical. By examination of the profiles, it will be appreciated that areas A_{70} represent additional flow area for engine exhaust at the exit plane P_{70} of the second stage exhaust nozzle 28.

In Fig. 5b, the NSI lobed nozzle 86 is again overlaid in combination with a section view of the second stage exhaust nozzle at exit plane P_{72} . The profile of the NSI nozzle is shown in dashed lines in areas where the nozzle 86 structurally differs from the second stage nozzle 28 and a dotted line 88 establishes a minimum upper flow boundary for the second stage nozzle 28. By examination thereof, it will be appreciated, that areas A_{72} represent additional flow area for engine exhaust at the exit plane P_{72} of the second stage exhaust nozzle 28. Accordingly, the total flow area at each of the exit planes P_{70} , P_{72} is larger when compared to the baseline NSI lobed nozzle 86, and, as such, the second stage nozzle 28 is less restrictive with respect to the flow of engine exhaust.

Summary and Alternate Embodiments of the Invention

Returning to Fig. 2, the multi-stage mixer/ejector 20 employs various mechanisms, some known in the art and others which are the subject of this invention, to effect significant IR signature reduction while maintaining and/or improving engine performance. Firstly, as is known in the art, each stage of the mixer/ejector 20 introduces cooling air SF_1 , SF_2 into the primary exhaust flow PF for reducing engine exhaust

temperature. Fluid mixing/pumping is achieved by a venturi effect which relies on the high velocity primary exhaust flow PF to entrain the secondary flows SF_1 , SF_2 of cooling air. As such, the need for additional apparatus to force or pump fluid is eliminated. Furthermore, the shroud means 32 substantially envelops the first and second stage
5 nozzles 24, 28 and, accordingly, serves to occlude the exterior surfaces thereof. Inasmuch as the temperature of such surfaces may be elevated, the shroud means 32 prevents direct viewing of the nozzles 24, 28 and, accordingly, diminishes or eliminates the IR signature radiated from such surfaces.

The staggered configuration of the penetrating lobes 60, 62 or 70, 72 facilitates
10 entrainment of cooling air into the primary exhaust flow PF without degrading engine performance. Firstly, by staggering the lobes 60, 62 or 70, 72, each nozzle 24 or 28 produces two ejector pumps in series, i.e., a first ejector pump at the exit plane P_{60} or P_{70} of the first plurality of penetrating lobes 60 or 70, and a second ejector pump at the exit plane P_{62} , P_{72} of the second plurality of penetrating lobes 62, or 72. As such, the fluid
15 dynamic pumping is augmented to (i) entrain more cooling fluid for suppressing the IR signature of the exhaust plume and (ii) reduce back-pressure for improving engine performance. Secondly, by staggering the penetrating lobes 60, 62 or 70, 72, it is possible to situate individual lobes in the core region of the primary flow without creating a restrictive "choke point" at any one axial station or plane. As such, further IR
20 suppression is achievable without degrading performance.

In the described embodiment, each nozzle, 24 or 28, in combination with its respective shroud, 42 or 48, maintains engine performance, collectively, the multi-stage mixer/ejector 20 improves engine performance by about 1 - 6%. Furthermore, each
25 exhaust nozzle, 24 or 28, in combination with its respective shroud, 42 or 48, is capable of effecting a 30 - 40% diffusion of IR energy within about two (2) diameters downstream of the nozzle, wherein the diameter is the measured relative to the diameter of the engine exhaust cowling 38. Collectively, the multi-stage mixer/ejector 20 effects an energy reduction on the order of about 60 - 80% from the high temperature exhaust E_{HT} to the cooled exhaust E_C .

30 While the IR suppressors of the prior art and the exhaust nozzles used therein typically require multiple forming and assembly steps, the multi-stage mixer/ejector 20

may be formed from conventional low-cost fabrication techniques such as casting or press molding. For example, a highly accurate mold may be fabricated by forming a stereolithography model of the exhaust nozzle, and subsequently, casting a wear and temperature resistance material over the stereolithography model to form a filled casting.

5 The polymer used in the stereolithography process is then removed in a high temperature furnace to form an accurate casting of the exhaust nozzle. Yet another example includes the use of a hydro-forming process wherein a sheet-metal workpiece is fabricated which approximates the size and shape of the nozzle. Hydrostatic pressure is then applied to press-mold the workpiece against an accurate three-dimensional solid model of the

10 nozzle to form the final nozzle configuration. While exhaust nozzles and/or ducts of the prior art typically include individually fabricated and assembled turning vanes for directing exhaust flow, the inset lobe configuration of the second stage exhaust nozzle 28 produces turning vanes 80 as an integral part of the nozzle wall.

Although the invention has been shown and described with respect to exemplary

15 embodiments thereof, it should be understood by those skilled in the art that other changes, omissions and additions may be made therein and thereto, without departing from the spirit and scope of the present invention. For example, while the first stage exhaust nozzle 24 of the mixer/ejector 20 includes an equal number of alternating perimeter and core penetrating lobes 60, 62, it will be understood that the number of

20 lobes need not be equal nor be alternating with respect to each other. Such configuration is shown in Fig. 6a wherein a core penetrating lobe 62' is disposed between pairs of perimeter penetrating lobes 60'. Furthermore, while the penetrating lobes 60, 62 of the first stage exhaust nozzle 24 are shown to be substantially radial, it should be appreciated that the penetrating lobes could be swirled to effect axial rotation of the exhaust flow.

25 Moreover, while the outlet end of the second stage exhaust nozzle 28 defines a substantially rectangular geometric profile, it will be appreciated that other shapes will accommodate the inset configuration of the penetrating lobes 70, 72. For example, in Figs. 6b and 6c, the outlet end may define an elliptical geometric profile as shown in Fig. 6b, or an hour-glass shape as depicted in Fig. 6c. In other embodiments of the

30 invention, the adjoined lobes may include additional penetrating lobes to define a third, fourth or higher plurality of penetrating lobes. Such example is depicted in Fig. 6d

wherein the adjoined lobes 30 include a first, second and third plurality of penetrating lobes 60', 62', and 64', respectively, and wherein each plurality of penetrating lobes 60', 62', 64' terminate at a distinct exit plane P'. While in the described embodiment, each of the penetrating lobes 70, 72 of the second stage nozzle 28 terminate
5 along a substantially vertical plane, it will be appreciated that the end face 70_{EF} may be stepped or inclined so as to effect a gradual stagger of the penetrating lobes in an axial direction.

What is claimed is:

CLAIMS

1 1. A multi-stage mixer/ejector (20) including at least one exhaust nozzle (24
2 or 28), the exhaust nozzle (24 or 28) having an inlet conduit adapted for receiving a
3 primary flow PF of engine exhaust and a plurality of adjoined lobes (30) integrally
4 formed in combination with the inlet conduit and defining an outlet end of the
5 exhaust nozzle (24 or 28), the adjoined lobes (30), furthermore, being adapted for
6 admixing a secondary flow SF of low-temperature gaseous fluid with the primary
7 flow PF, the multi-stage mixer/ejector (20) being characterized by:

8 said adjoined lobes (30) of said exhaust nozzle (24 or 28) defining a first and
9 second plurality of penetrating lobes (60, 62 or 70, 72), said penetrating
10 lobes (60, 62 or 70, 72) being axially staggered with respect to each other.

1 2. The multi-stage mixer/ejector (20) according to claim 1 wherein at least one
2 of said plurality of penetrating lobes (60 or 62, 70 or 72) extends into a core region
3 of the exhaust nozzle (24 or 28).

1 3. A multi-stage mixer/ejector (20) operative to suppress the infrared signature
2 radiated from a primary flow PF of high-temperature exhaust of an engine (12), the
3 multi-stage mixer ejector (20) having tandemly arranged first and second stage
4 exhaust nozzles (24, 28), and a shroud means (32) enveloping the exhaust nozzles
5 (24, 28), said exhaust nozzles (24, 28) in combination with said shroud means (32),
6 operative to entrain a secondary flow SF of low-temperature gaseous fluid into the
7 primary flow;

8 the first stage exhaust nozzle (24) including:

9 an inlet conduit (36) adapted for receiving the primary flow PF of engine
10 exhaust;

11 a plurality of adjoined lobes (30) integrally formed in combination with said
12 inlet conduit (36) and defining an outlet end of the exhaust nozzle (24), each of said
13 adjoined lobes (30) being substantially radially oriented with respect to a
14 longitudinal axis (24_A) defined by said outlet end, said adjoined lobes (30), in

15 combination with said shroud means (32), being adapted for admixing the secondary
16 flow SF of low-temperature gaseous fluid with said primary flow PF of engine
17 exhaust;

18 said multi-stage ejector (20) being characterized by:

19 said adjoined lobes (30) of said first stage exhaust nozzle (24) defining a first
20 and second plurality of penetrating lobes (60, 62), said penetrating lobes (60, 62)
21 each defining an external flow trough (30_{EFT}), said external flow troughs (30_{EFT}) of
22 said first plurality (60) defining a core region (CR);

23 said second plurality of penetrating lobes (62) projecting axially downstream
24 of said first plurality of penetrating lobes (60) and extending into said core
25 region (CR) so as to direct the secondary flow SF of low temperature gaseous fluid
26 deeply into the primary flow PF of engine exhaust.

1 4. The multi-stage mixer/ejector (20) according to claim 3 wherein the end
2 points (62_E) of said second plurality of penetrating lobes (62) are proximal to said
3 longitudinal axis (24_A).

1 5. The multi-stage mixer/ejector (20) according to claim 3 wherein said first
2 and second plurality of penetrating lobes (60, 62) are alternately disposed about the
3 periphery of the first stage exhaust nozzle (24).

1 6. The multi-stage mixer/ejector (20) according to claim 3 wherein said second
2 plurality of penetrating lobes (62) are equiangularly spaced about said longitudinal
3 axis (24_A).

1 7. The multi-stage mixer/ejector (20) according to claim 3 wherein each of said
2 external flow troughs (30_{EFT}) of said second plurality of penetrating lobes (62) define
3 a smooth curve (66) along its length, said smooth curve (66) having a slope less than
4 about 30 degrees relative to said longitudinal axis (24_A).

1 8. The multi-stage mixer/ejector (20) according to claim 7 wherein said second
2 plurality of penetrating lobes (62) taper in radial height and width dimension along
3 its length.

1 9. The multi-stage mixer/ejector (20) according to claim 3 wherein said first
2 and second plurality of penetrating lobes (60, 62) are alternately disposed about the
3 periphery of the first stage exhaust nozzle (24), and wherein said second plurality of
4 penetrating lobes (62) are equiangularly spaced about said longitudinal axis (24_A).

1 10. The multi-stage mixer/ejector (20) according to claim 9 wherein each of said
2 external flow troughs (30_{EFT}) of said second plurality of penetrating lobes (62) define
3 a smooth curve (66) along its length, said smooth curve (66) having a slope less than
4 about 30 degrees relative to said longitudinal axis (24_A).

1 11. The multi-stage mixer/ejector (20) according to claim 10 wherein said
2 second plurality of penetrating lobes (62) taper in radial height and width dimension
3 along its length.

1 12. A multi-stage mixer/ejector (20) operative to suppress the infrared signature
2 radiated from a primary flow PF of high-temperature exhaust of an engine (12), the
3 multi-stage mixer ejector (20) having tandemly arranged first and second stage
4 exhaust nozzles (24, 28), and a shroud means (32) enveloping the exhaust nozzles
5 (24, 28), said exhaust nozzles (24, 28), in combination with said shroud means (32),
6 operative to entrain a secondary flow SF of low-temperature gaseous fluid into the
7 primary flow,

8 the second stage exhaust nozzle (28) including:

9 an inlet conduit (46) adapted for receiving the primary flow PF of engine
10 exhaust;

11 a plurality of adjoined lobes (30) integrally formed in combination with said
12 inlet conduit (46) and defining an outlet end of the exhaust nozzle (28), each of said
13 adjoined lobes (30) being substantially perpendicular with respect midplane P_M
14 defined by said outlet end, said adjoined lobes (30), in combination with said shroud

15 means (32), being adapted for admixing the secondary flow SF of low-temperature
16 gaseous fluid with the primary flow PF of partially cooled exhaust to produce a
17 primary flow of cooled/suppressed engine exhaust;

18 said multi-stage mixer/ejector (20) being characterized by:

19 said adjoined lobes (30) defining a first and second plurality of penetrating
20 lobes (70, 72), said penetrating lobes (70, 72) each defining an external flow
21 trough (30_{EFT}), said external flow troughs (30_{EFT}) of said first plurality (70) defining a
22 core region (CR);

23 said penetrating lobes (70, 72) furthermore being inset with respect to each
24 other; and

25 said second plurality of penetrating lobes (72) projecting axially downstream
26 of said first plurality of penetrating lobes (70) and extending into said core
27 region (CR) so as to direct the secondary flow SF of low temperature gaseous fluid
28 deeply into the primary flow PF of engine exhaust.

1 13. The multi-stage mixer/ejector (20) according to claim 12 wherein the exhaust
2 nozzle (28) is also operative to suppress the infrared signature radiated from the hot
3 metal components of the engine (12), and wherein said penetrating lobes (70,72)
4 define a plurality of turning vanes (80) adapted for redirecting the primary exhaust
5 flow PF.

1 14. The multi-stage mixer/ejector (20) according to claim 12 wherein first
2 plurality of penetrating lobes (70) define an exit plane P_{70} , and wherein said first and
3 second plurality of penetrating lobes (70, 72) are inset at an axial location (74)
4 inboard of said exit plane (P_{70}) for preventing direct line-of-sight viewing into said
5 exhaust nozzle (28).

1 15. The multi-stage mixer/ejector (20) according to claim 12 wherein said inlet
2 conduit (46) defines a substantially circular geometric profile and said penetrating
3 lobes (70, 72) define a substantially rectangular geometric profile.

1 16. The multi-stage mixer/ejector (20) according to claim 12 wherein said
2 second plurality of penetrating lobes (72) define an exit plane P_{72} , and wherein said
3 second plurality of penetrating lobes (72) fully traverse said core region (CR) so as
4 to divide the primary flow into a plurality of discrete flow segments.

5

6 17. A multi-stage mixer/ejector (20) operative to suppress the infrared signature
7 radiated from a primary flow PF of high-temperature exhaust of an engine (12), the
8 multi-stage mixer ejector (20) having tandemly arranged first and second stage
9 exhaust nozzles (24, 28), and a shroud means (32) enveloping the exhaust nozzles
10 (24, 28),

11 the first stage exhaust nozzle (24) including:

12 an inlet conduit (36) adapted for receiving the primary flow PF of high-
13 temperature engine exhaust;

14 a plurality of adjoined lobes (30) integrally formed in combination with said
15 inlet conduit (36) and defining an outlet end of the exhaust nozzle (24), each of said
16 adjoined lobes (30) being substantially radially oriented with respect to a
17 longitudinal axis (24_A) defined by said outlet end, said adjoined lobes (30), in
18 combination with said shroud means (32), being adapted for admixing the secondary
19 flow SF of low-temperature gaseous fluid with said primary flow PF of high-
20 temperature exhaust to produce a primary flow PF of partially-cooled engine
21 exhaust;

22 said second stage exhaust nozzle (28) including:

23 an inlet conduit (46) adapted for receiving the primary flow PF of partially
24 cooled engine exhaust;

25 a plurality of adjoined lobes (30) integrally formed in combination with said
26 inlet conduit (46) and defining an outlet end of the exhaust nozzle (28), each of said
27 adjoined lobes (30) being substantially perpendicular with respect midplane P_M
28 defined by said outlet end, said adjoined lobes (30), in combination with said shroud
29 means (32), being adapted for admixing the secondary flow SF of low-temperature
30 gaseous fluid with the primary flow PF of partially cooled exhaust to produce a
31 primary flow of cooled/suppressed engine exhaust;

32 said multi-stage ejector (20) being characterized by:
33 said adjoined lobes (30) of said first stage exhaust nozzle (24) defining a first
34 and second plurality of penetrating lobes (60, 62), said penetrating lobes (60, 62)
35 each defining an external flow trough (30_{EFT}), said external flow troughs (30_{EFT}) of
36 said first plurality (60) defining a core region (CR);
37 said second plurality of penetrating lobes (62) projecting axially downstream
38 of said first plurality of penetrating lobes (60) and extending into said core
39 region (CR) so as to direct the secondary flow SF of low temperature gaseous fluid
40 deeply into the primary flow PF of high temperature engine exhaust; and
41 said adjoined lobes (30) of said second stage exhaust nozzle (28) defining a
42 first and second plurality of penetrating lobes (70, 72), said penetrating
43 lobes (70, 72) each defining an external flow trough (30_{EFT}), said external flow
44 troughs (30_{EFT}) of said first plurality (70) defining a core region (CR);
45 said penetrating lobes (70, 72) furthermore being inset with respect to each
46 other; and
47 said second plurality of penetrating lobes (72) projecting axially downstream of said
48 first plurality of penetrating lobes (70) and extending into said core region (CR) so
49 as to direct the secondary flow SF of low temperature gaseous fluid deeply into the
50 primary flow PF of high temperature engine exhaust.

1 18. The multi-stage mixer/ejector (20) according to claim 17 wherein said shroud
2 means (32) includes first and second shrouds (42, 48) enveloping said first and
3 second exhaust nozzles (24, 28), respectively, said second shroud enveloping an
4 outlet end (42_o) of said first shroud (42).

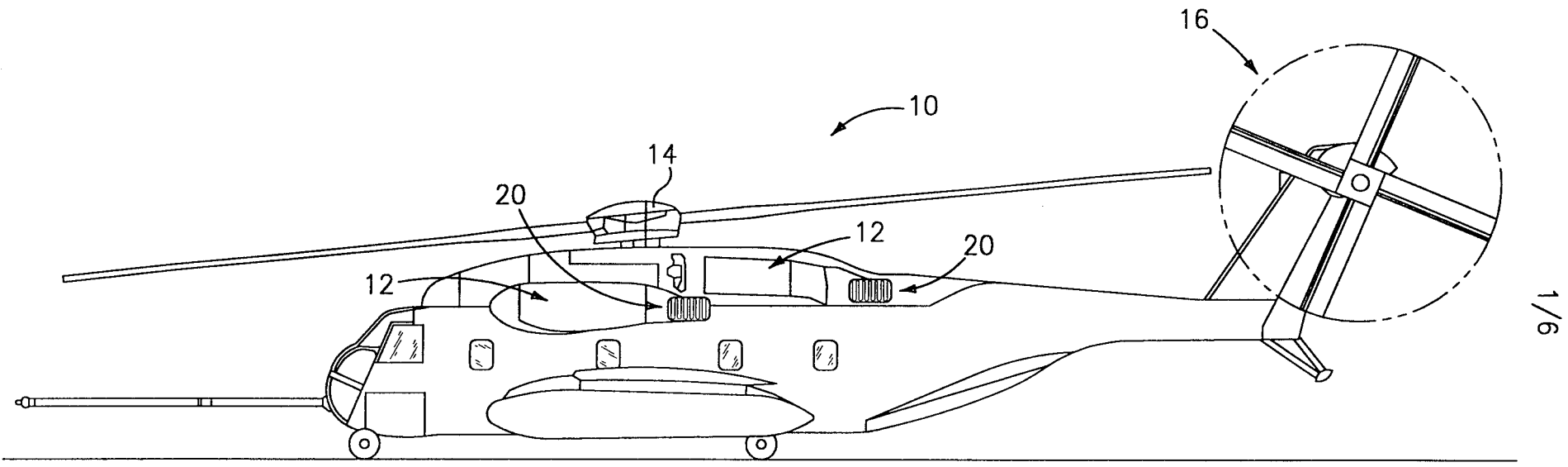

1/6

FIG. 1

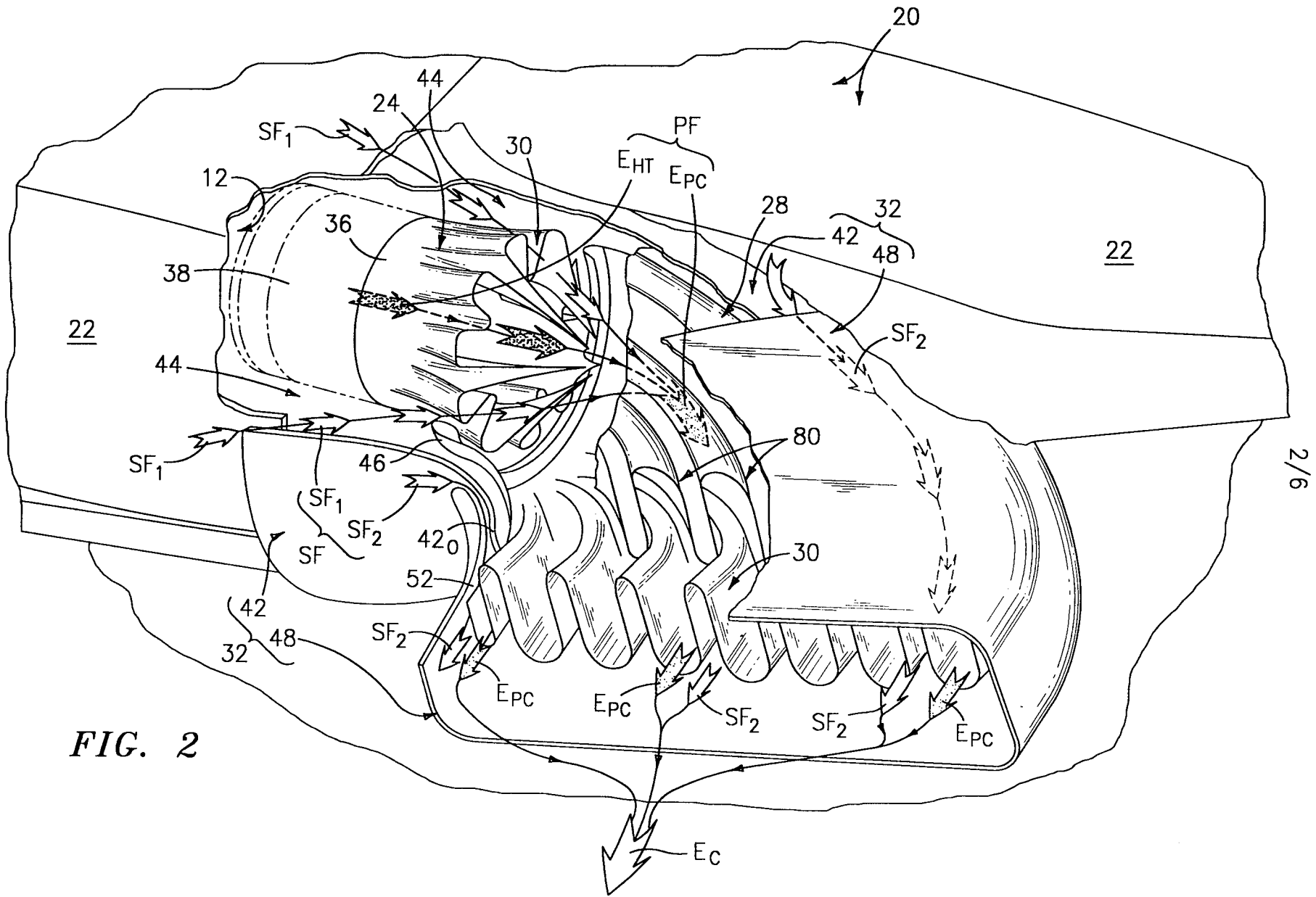

FIG. 2

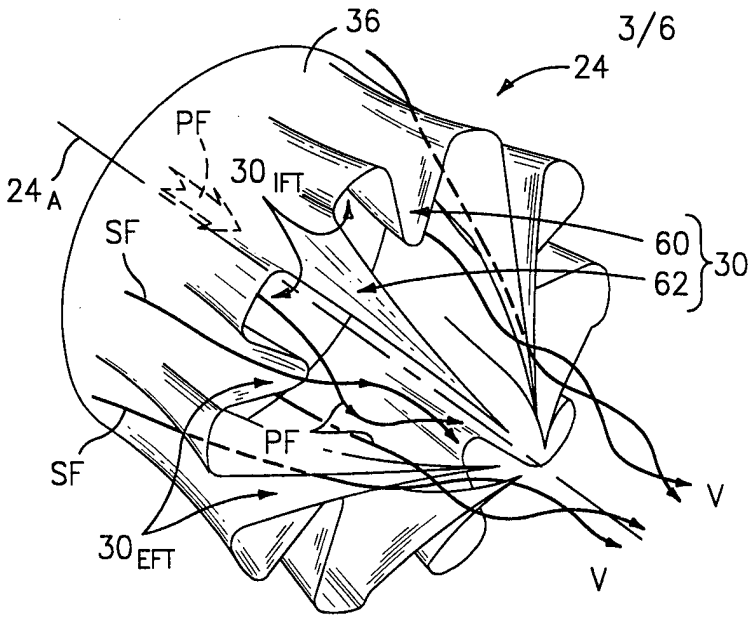

FIG. 3a

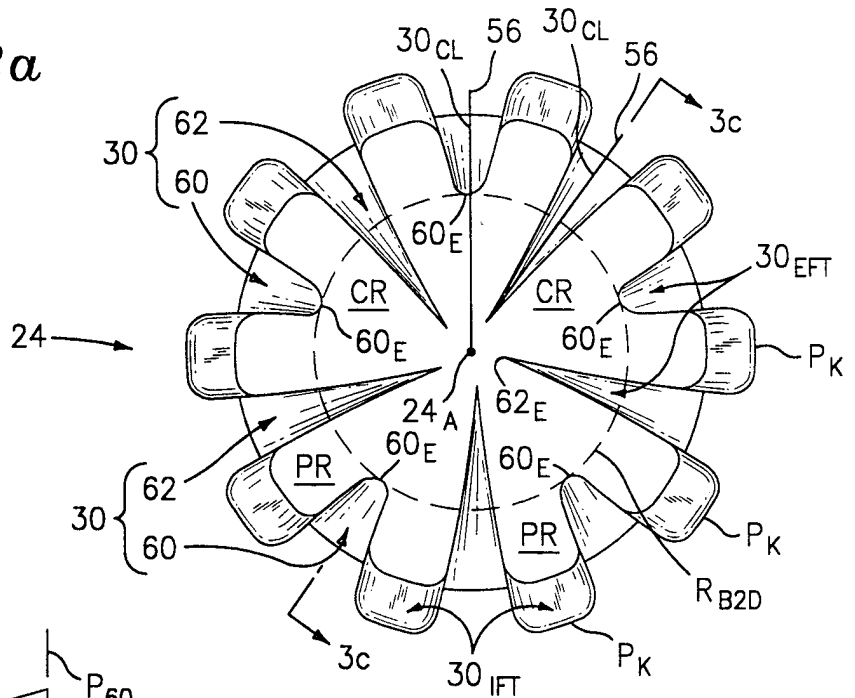

FIG. 3b

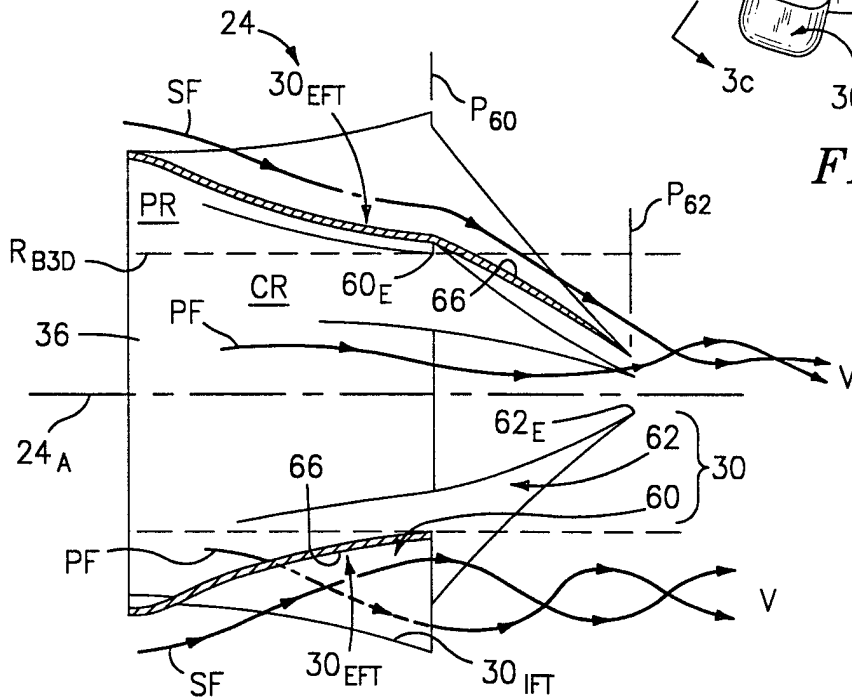

FIG. 3c

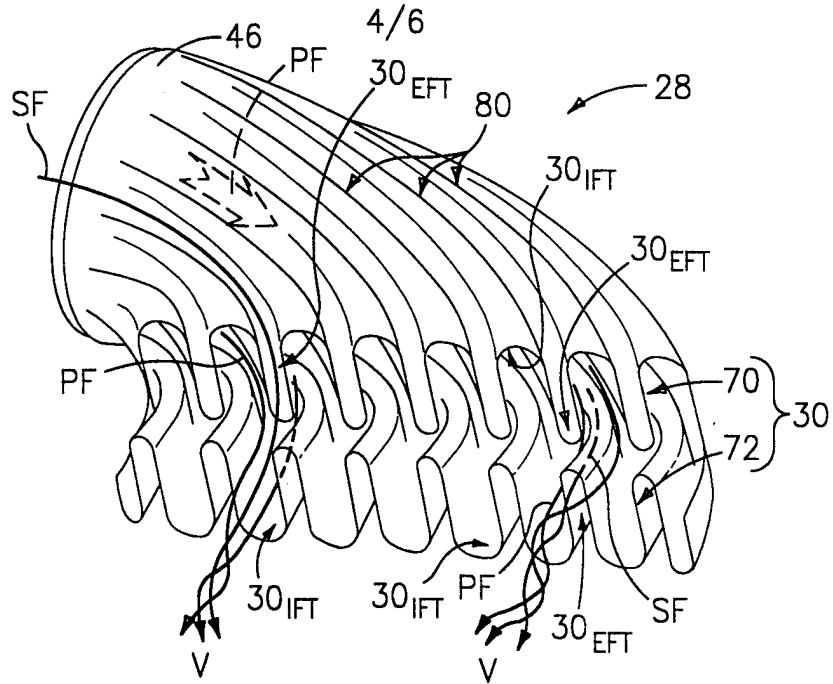

FIG. 4a

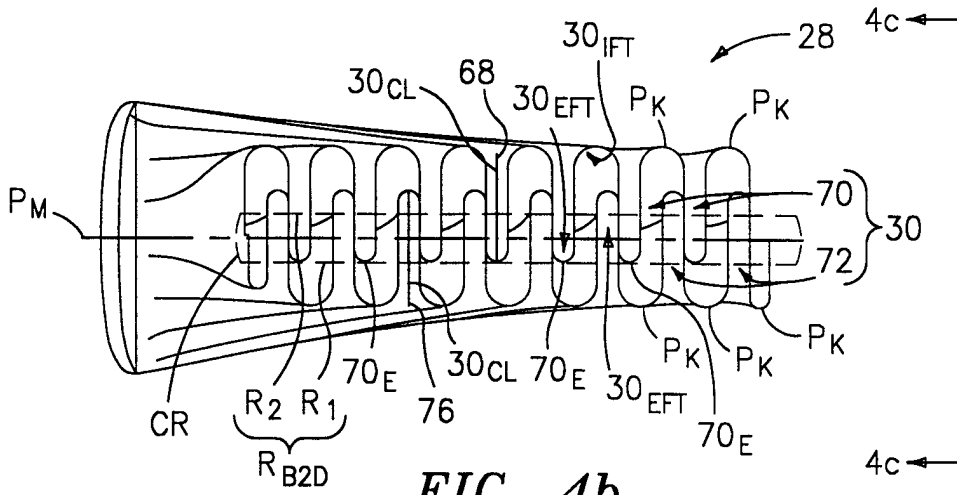

FIG. 4b

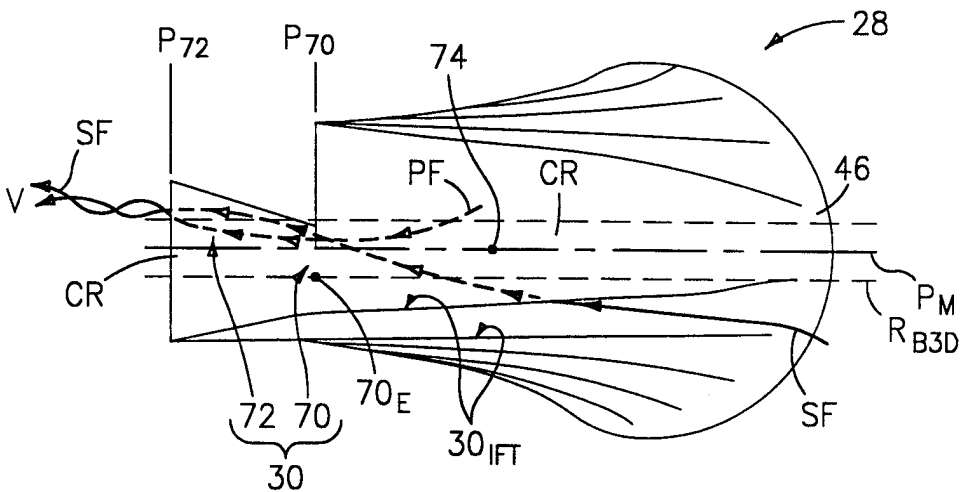

FIG. 4c

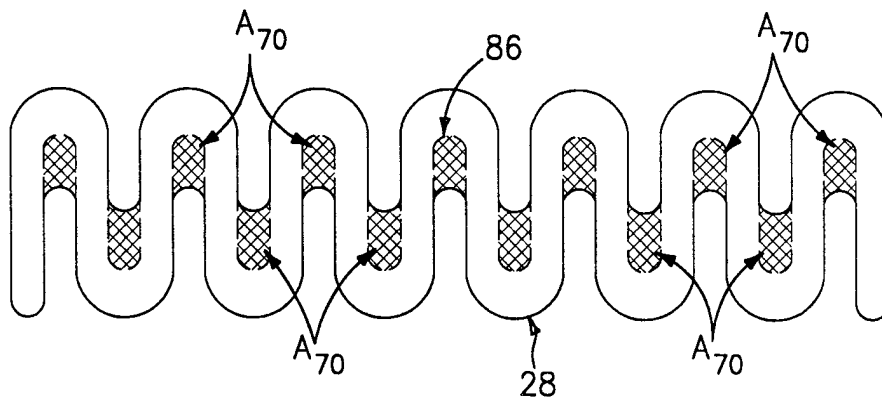

FIG. 5a

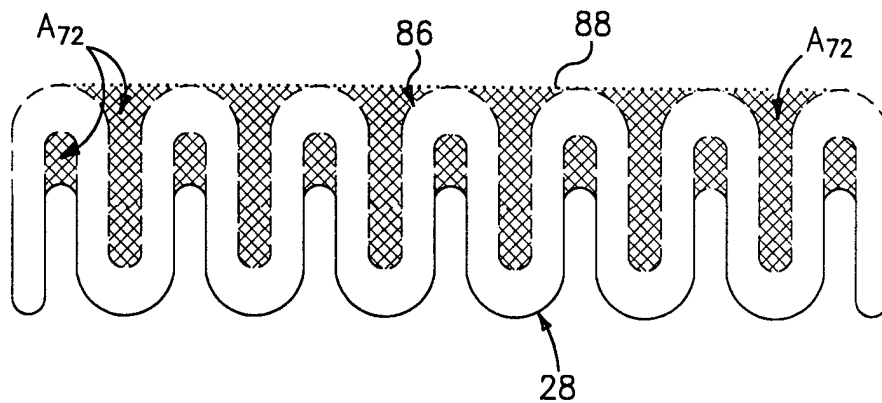

FIG. 5b

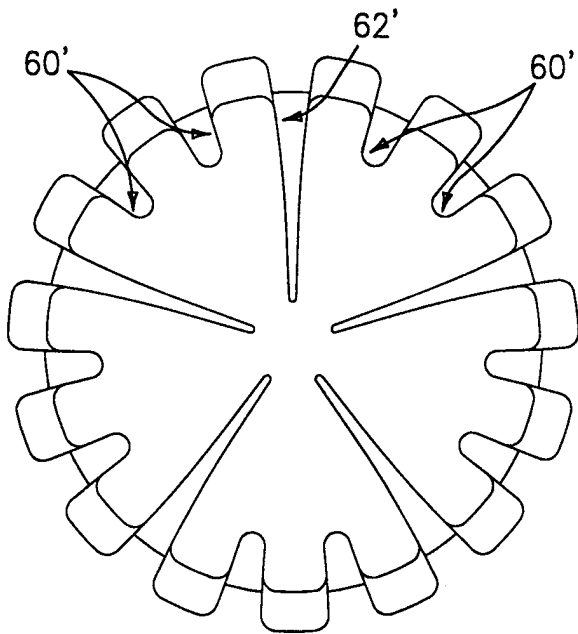

FIG. 6a

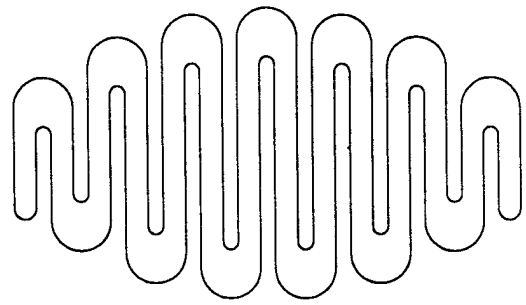

FIG. 6b

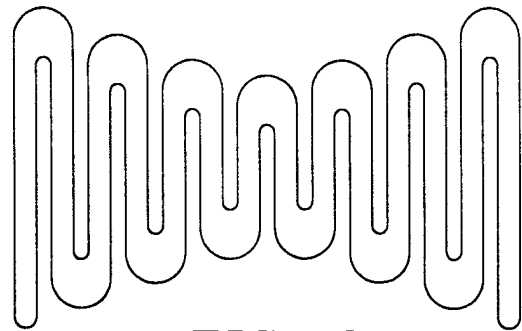

FIG. 6c

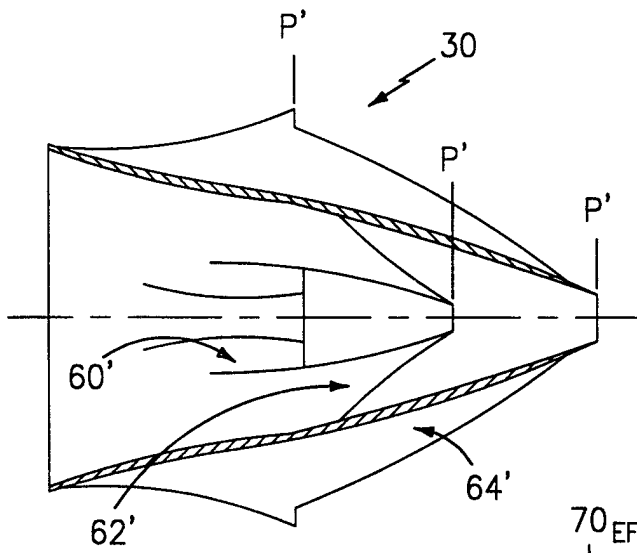

FIG. 6d

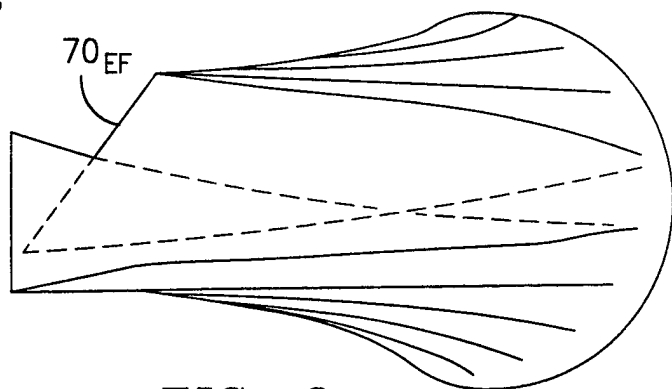

FIG. 6e

INTERNATIONAL SEARCH REPORT

Intern. Application No PCT/US 98/11853

A. CLASSIFICATION OF SUBJECT MATTER

IPC 6 F02K1/48 F02K1/38 F02K1/36 B64D33/04

According to International Patent Classification (IPC) or to both national classification and IPC

B. FIELDS SEARCHED

Minimum documentation searched (classification system followed by classification symbols)

IPC 6 F02K B64D

Documentation searched other than minimum documentation to the extent that such documents are included in the fields searched

Electronic data base consulted during the international search (name of data base and, where practical, search terms used)

C. DOCUMENTS CONSIDERED TO BE RELEVANT

Category °	Citation of document, with indication, where appropriate, of the relevant passages	Relevant to claim No.
X	GB 2 119 859 A (ROLLS ROYCE) 23 November 1983 see page 2, line 55 - line 100	1,2
Y	see page 3, line 56 - line 67; figures 2-4	3-18
Y	FR 2 515 735 A (ROLLS ROYCE) 6 May 1983	3-18
A	see page 2, line 2 - page 5, line 27; figures 1,2	1,2
Y	FR 2 087 076 A (BERTIN & CIE) 31 December 1971 see the whole document	3-18
A	EP 0 635 632 A (NORDAM ; UNITED TECHNOLOGIES CORP (US)) 25 January 1995 see abstract	1-18
	-/--	



Further documents are listed in the continuation of box C.



Patent family members are listed in annex.

° Special categories of cited documents :

- "A" document defining the general state of the art which is not considered to be of particular relevance
- "E" earlier document but published on or after the international filing date
- "L" document which may throw doubts on priority claim(s) or which is cited to establish the publication date of another citation or other special reason (as specified)
- "O" document referring to an oral disclosure, use, exhibition or other means
- "P" document published prior to the international filing date but later than the priority date claimed

- "T" later document published after the international filing date or priority date and not in conflict with the application but cited to understand the principle or theory underlying the invention
- "X" document of particular relevance; the claimed invention cannot be considered novel or cannot be considered to involve an inventive step when the document is taken alone
- "Y" document of particular relevance; the claimed invention cannot be considered to involve an inventive step when the document is combined with one or more other such documents, such combination being obvious to a person skilled in the art.
- "&" document member of the same patent family

Date of the actual completion of the international search

8 October 1998

Date of mailing of the international search report

15/10/1998

Name and mailing address of the ISA

European Patent Office, P.B. 5818 Patentlaan 2
NL - 2280 HV Rijswijk
Tel. (+31-70) 340-2040, Tx. 31 651 epo nl,
Fax: (+31-70) 340-3016

Authorized officer

Iverus, D

INTERNATIONAL SEARCH REPORT

Intern. Patent Application No

PCT/US 98/11853

C.(Continuation) DOCUMENTS CONSIDERED TO BE RELEVANT

Category °	Citation of document, with indication, where appropriate, of the relevant passages	Relevant to claim No.
X	GB 2 085 088 A (UNITED TECHNOLOGIES CORP) 21 April 1982	1,2
A	see the whole document ---	3-11
A	GB 2 160 265 A (ROLLS ROYCE) 18 December 1985 ---	
A	EP 0 761 956 A (UNITED TECHNOLOGIES CORP) 12 March 1997 ---	
A	US 3 048 376 A (HOWALD) 7 August 1962 ---	
A	US 3 084 505 A (CHERCHI) 9 April 1963 -----	

INTERNATIONAL SEARCH REPORT

Information on patent family members

International Application No

PCT/US 98/11853

Patent document cited in search report	A	Publication date	Patent family member(s)	Publication date
GB 2119859	A	23-11-1983	NONE	
FR 2515735	A	06-05-1983	GB 2114229 A CA 1210938 A DE 3239197 A JP 1355527 C JP 58085345 A JP 61002778 B US 4566270 A	17-08-1983 09-09-1986 11-05-1983 24-12-1986 21-05-1983 28-01-1986 28-01-1986
FR 2087076	A	31-12-1971	CA 927614 A DE 2121485 A GB 1345786 A US 3685612 A	05-06-1973 25-11-1971 06-02-1974 22-08-1972
EP 0635632	A	25-01-1995	AT 159567 T CA 2126272 A DE 69406370 D DE 69406370 T JP 7166959 A US 5440875 A	15-11-1997 26-12-1994 27-11-1997 26-03-1998 27-06-1995 15-08-1995
GB 2085088	A	21-04-1982	US 4401269 A CA 1159265 A FR 2491149 A JP 1656791 C JP 3015021 B JP 57083648 A	30-08-1983 27-12-1983 02-04-1982 13-04-1992 28-02-1991 25-05-1982
GB 2160265	A	18-12-1985	DE 3520726 A FR 2565631 A JP 61004849 A	12-12-1985 13-12-1985 10-01-1986
EP 0761956	A	12-03-1997	US 5638675 A JP 9105355 A US 5775095 A	17-06-1997 22-04-1997 07-07-1998
US 3048376	A	07-08-1962	NONE	
US 3084505	A	09-04-1963	NONE	