



(19) **United States**

(12) **Patent Application Publication**
TAKANO

(10) **Pub. No.: US 2017/0079066 A1**

(43) **Pub. Date: Mar. 16, 2017**

(54) **DEVICE**

H04W 74/08 (2006.01)

H04W 16/14 (2006.01)

H04W 72/04 (2006.01)

(71) Applicant: **SONY CORPORATION**, Tokyo (JP)

(72) Inventor: **Hiroaki TAKANO**, Saitama (JP)

(52) **U.S. Cl.**

CPC *H04W 74/004* (2013.01); *H04W 16/14* (2013.01); *H04W 72/0453* (2013.01); *H04W 74/0816* (2013.01); *H04L 5/14* (2013.01); *H04W 84/12* (2013.01)

(73) Assignee: **Sony Corporation**, Tokyo (JP)

(21) Appl. No.: **15/122,849**

(22) PCT Filed: **Jan. 29, 2015**

(57) **ABSTRACT**

(86) PCT No.: **PCT/JP2015/052584**

§ 371 (c)(1),

(2) Date: **Aug. 31, 2016**

There is provided a device including a control unit configured to control a wireless communication device for performing wireless communication of a cellular system so that the wireless communication device transmits a frame including duration information for setting a network allocation vector (NAV) using a frequency band shared between the wireless communication of the cellular system and wireless communication conforming to a wireless local area network (LAN) standard. The control unit controls a base station of the cellular system so that the wireless communication of the cellular system is performed using the frequency band in a period after the transmission of the frame.

(30) **Foreign Application Priority Data**

Mar. 18, 2014 (JP) 2014-055143

Publication Classification

(51) **Int. Cl.**

H04W 74/00 (2006.01)

H04L 5/14 (2006.01)

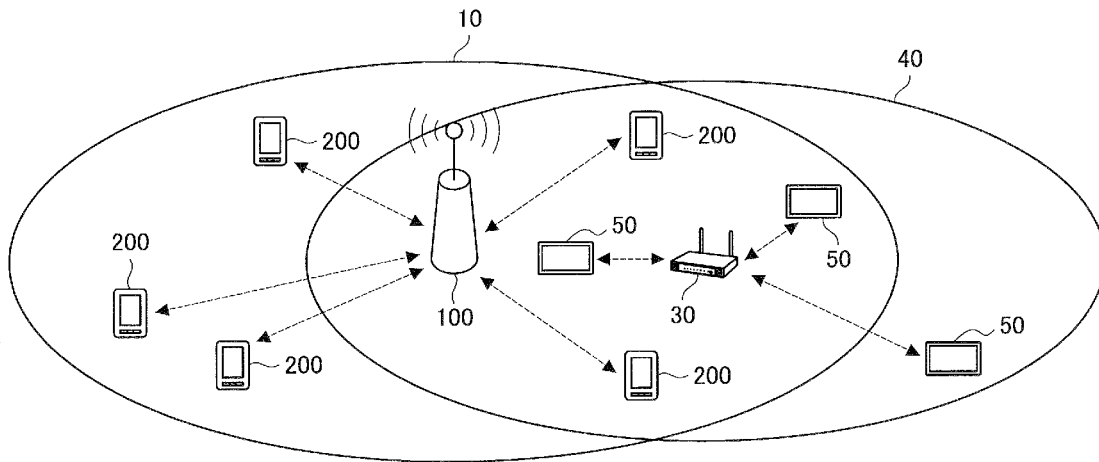


FIG. 1

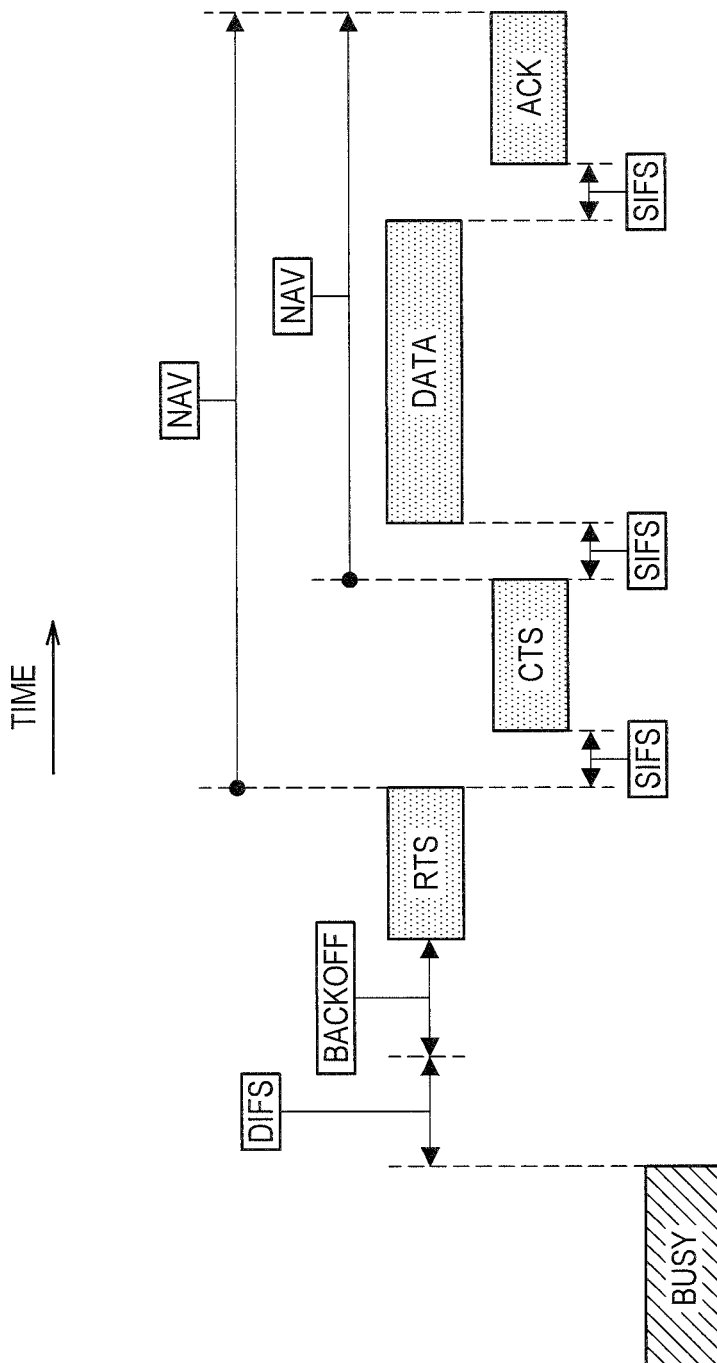


FIG. 2

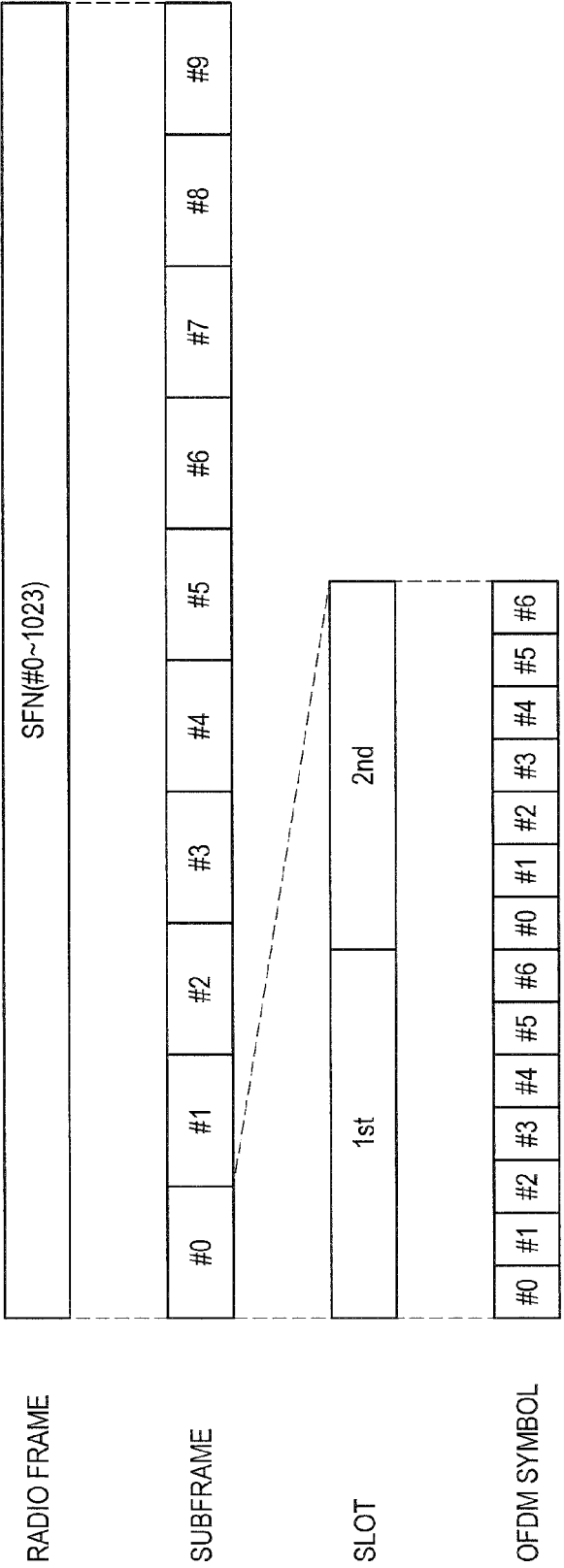


FIG. 3

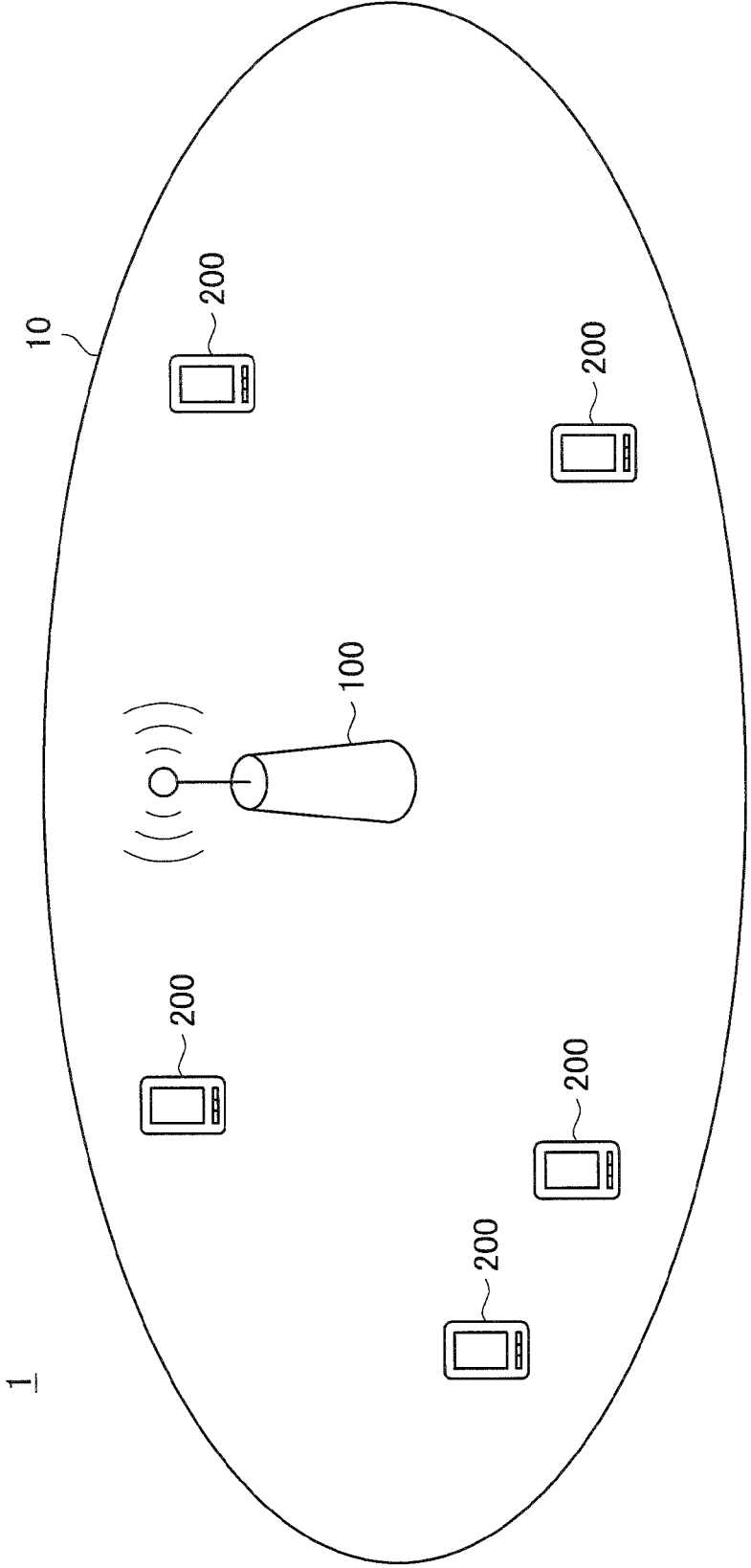


FIG. 4

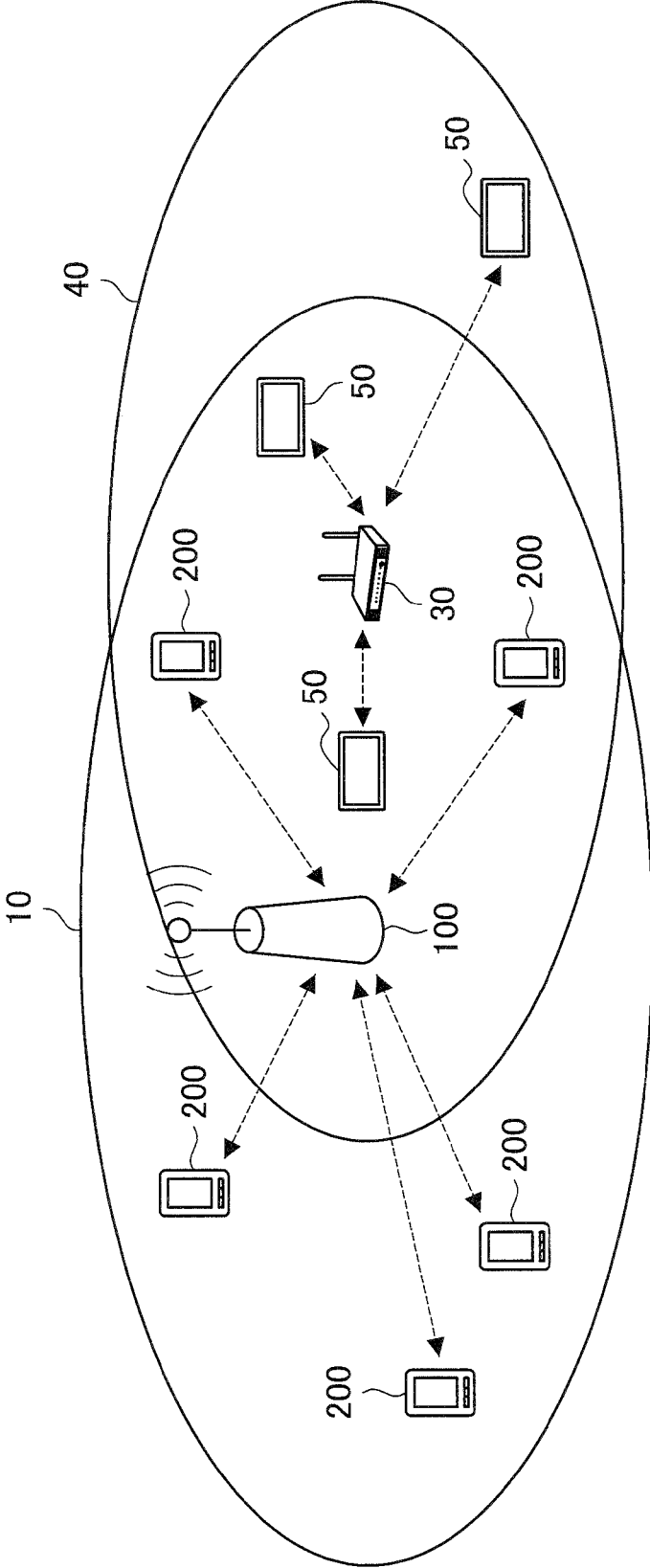


FIG. 5

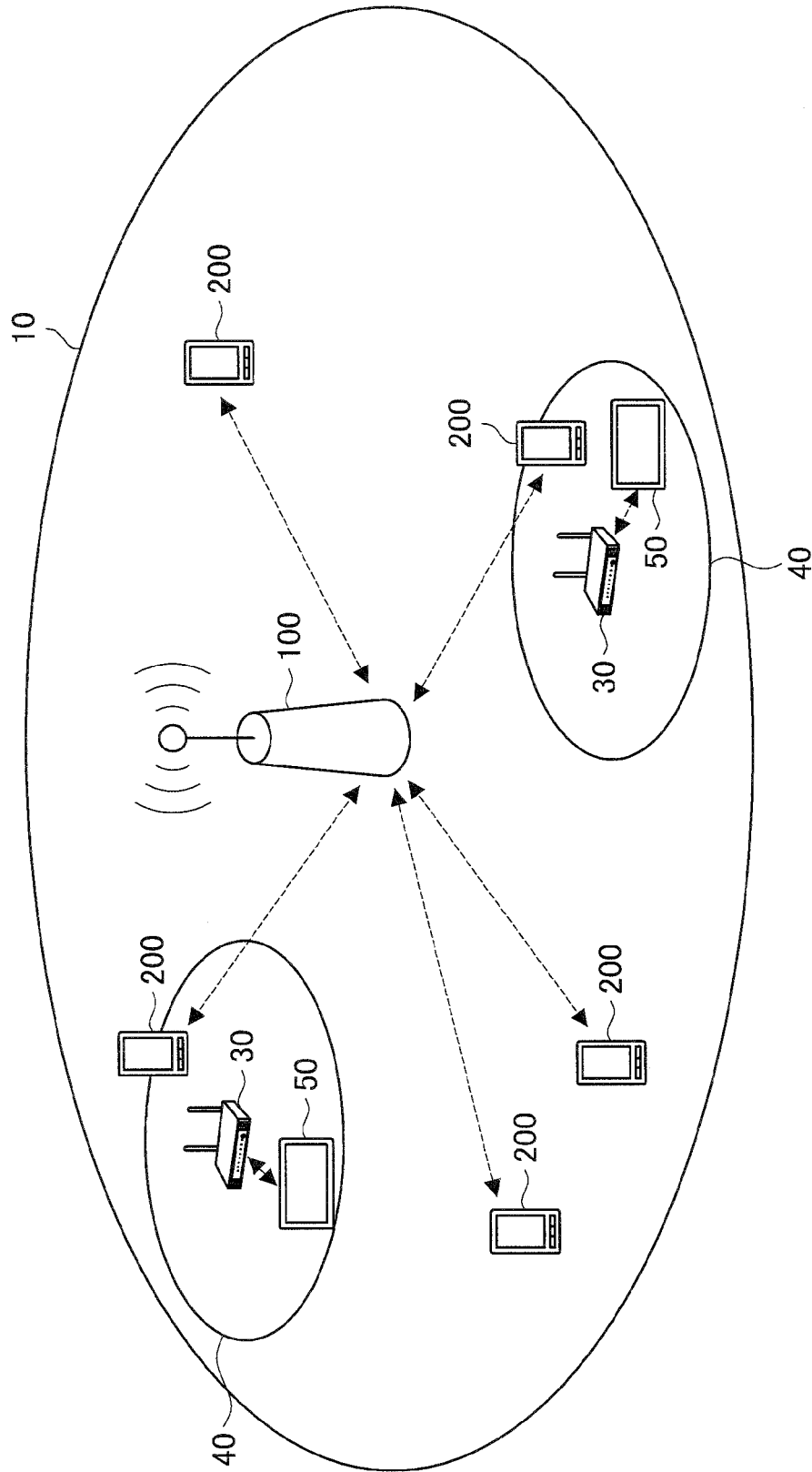


FIG. 6

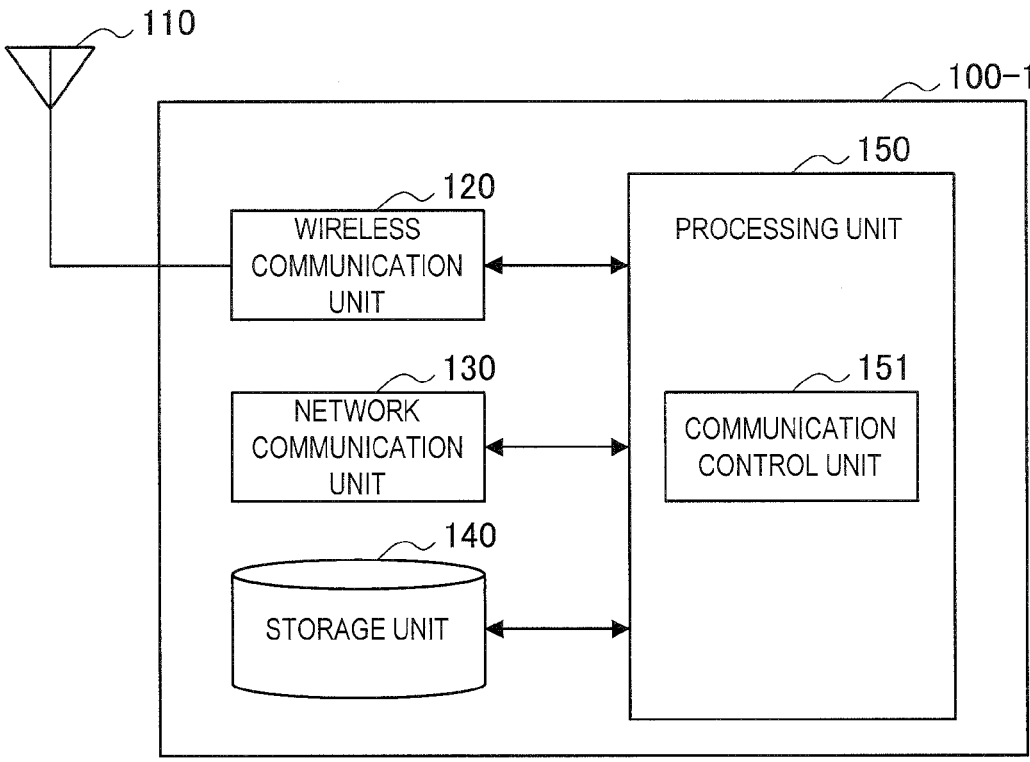


FIG. 7

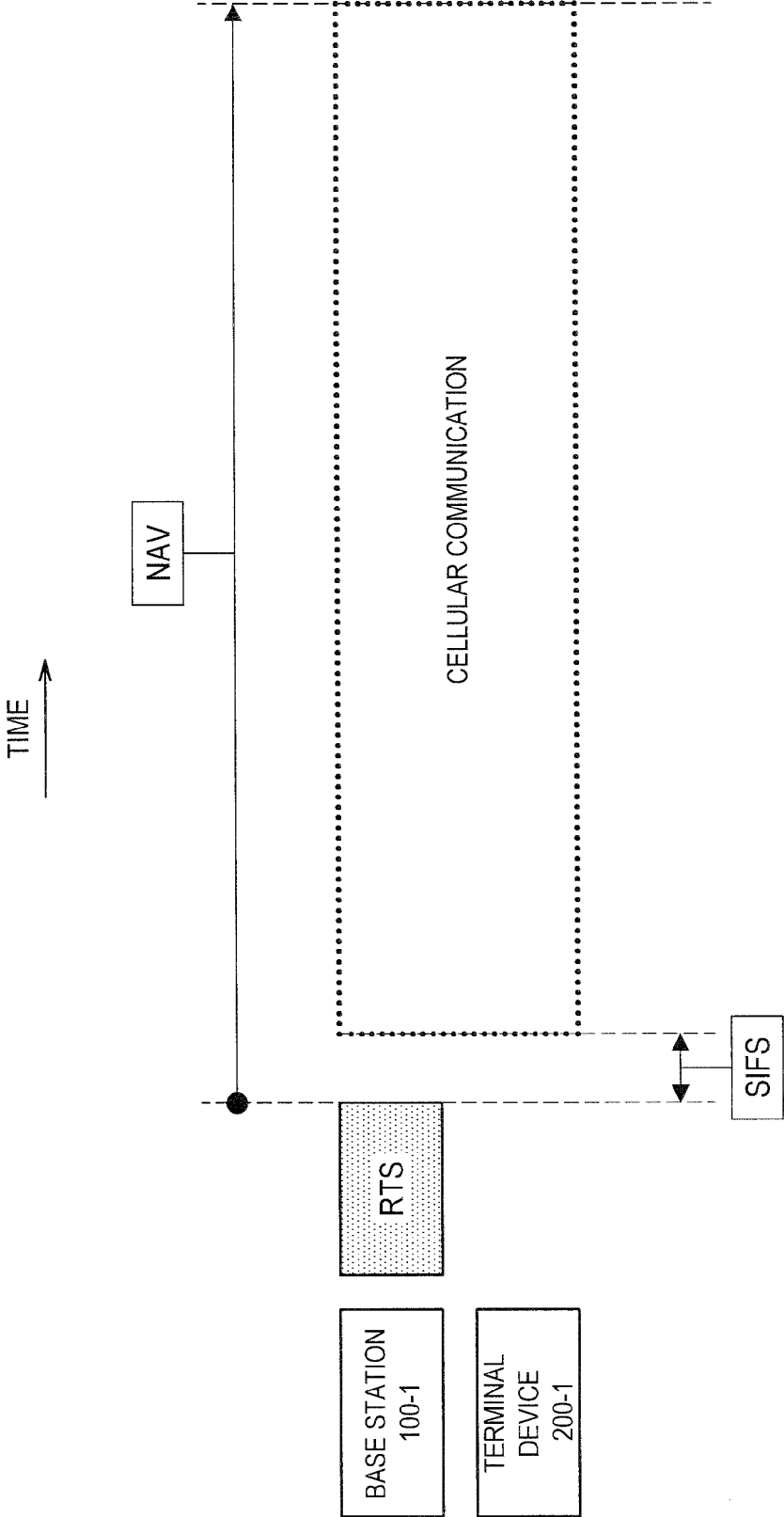


FIG. 8

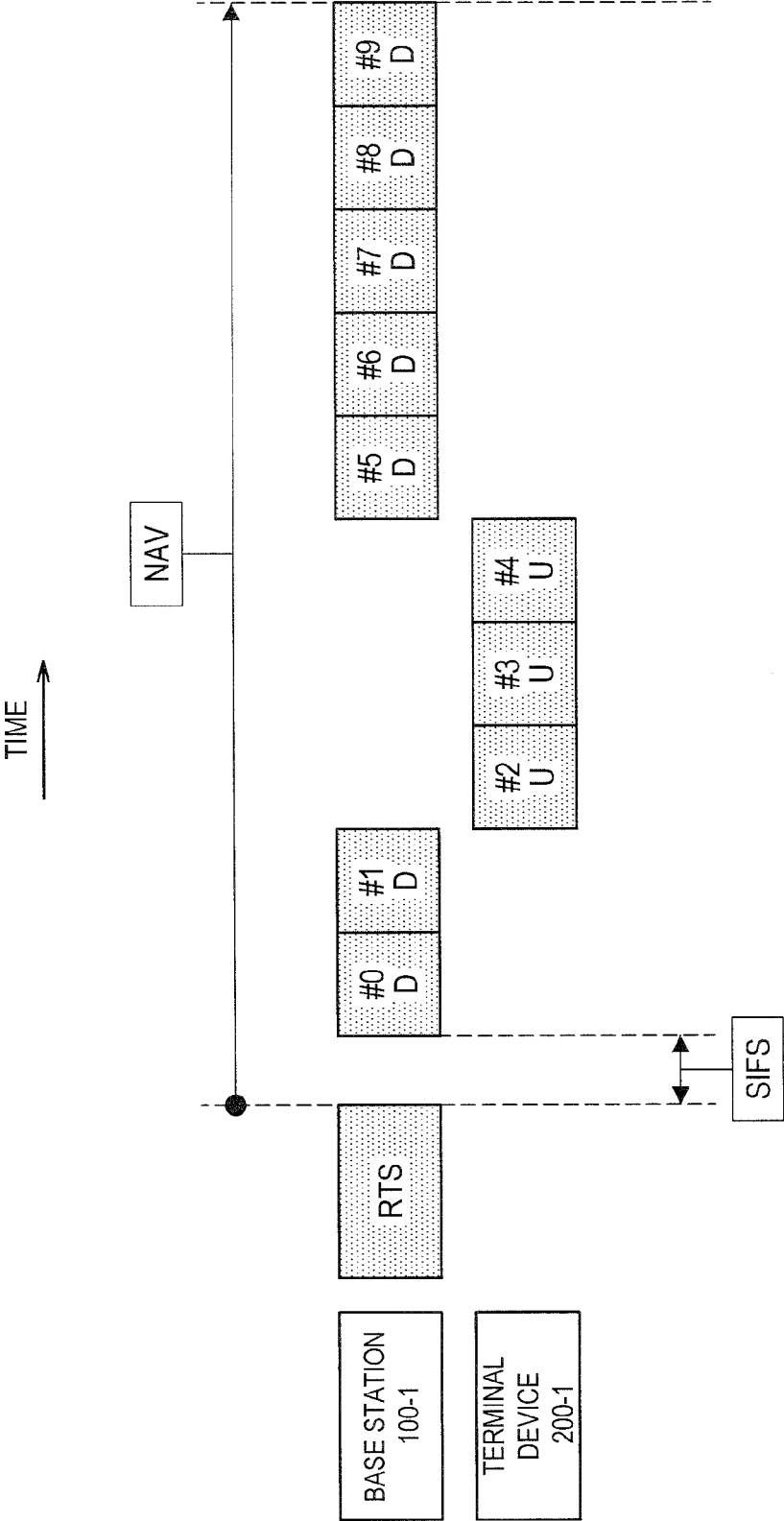


FIG. 9

TIME →

NAV

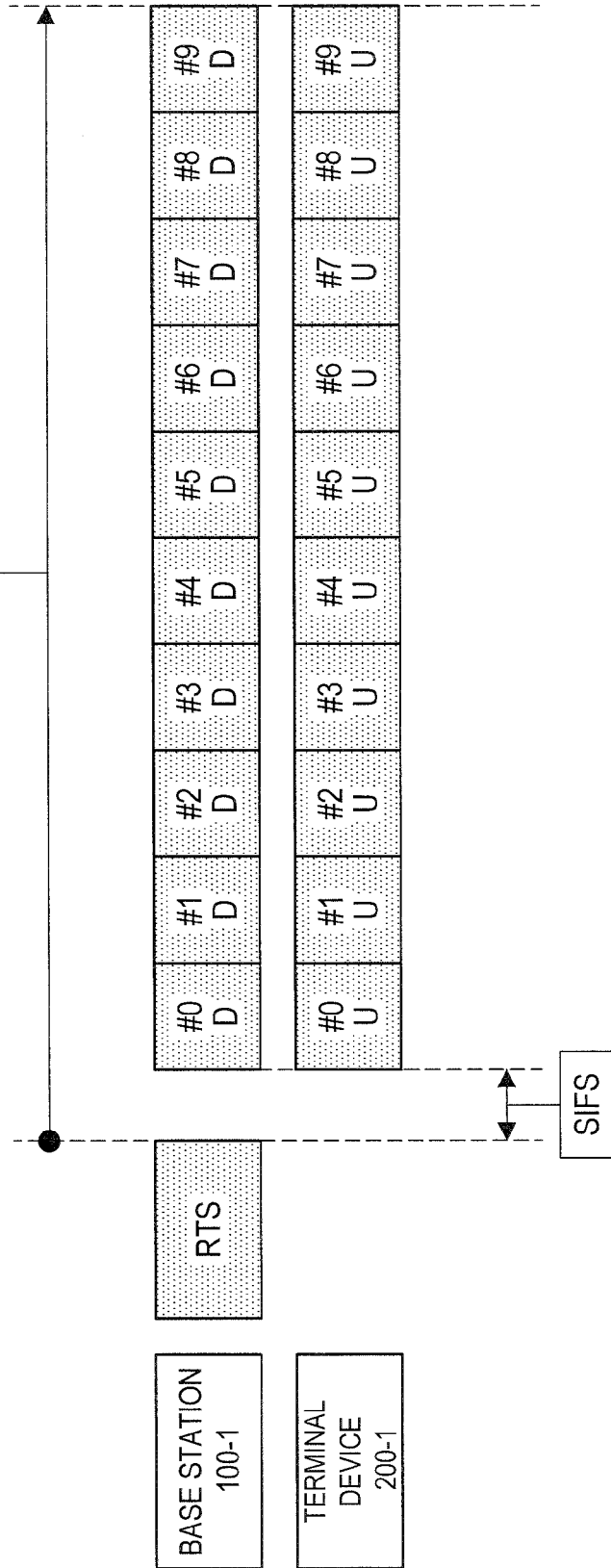
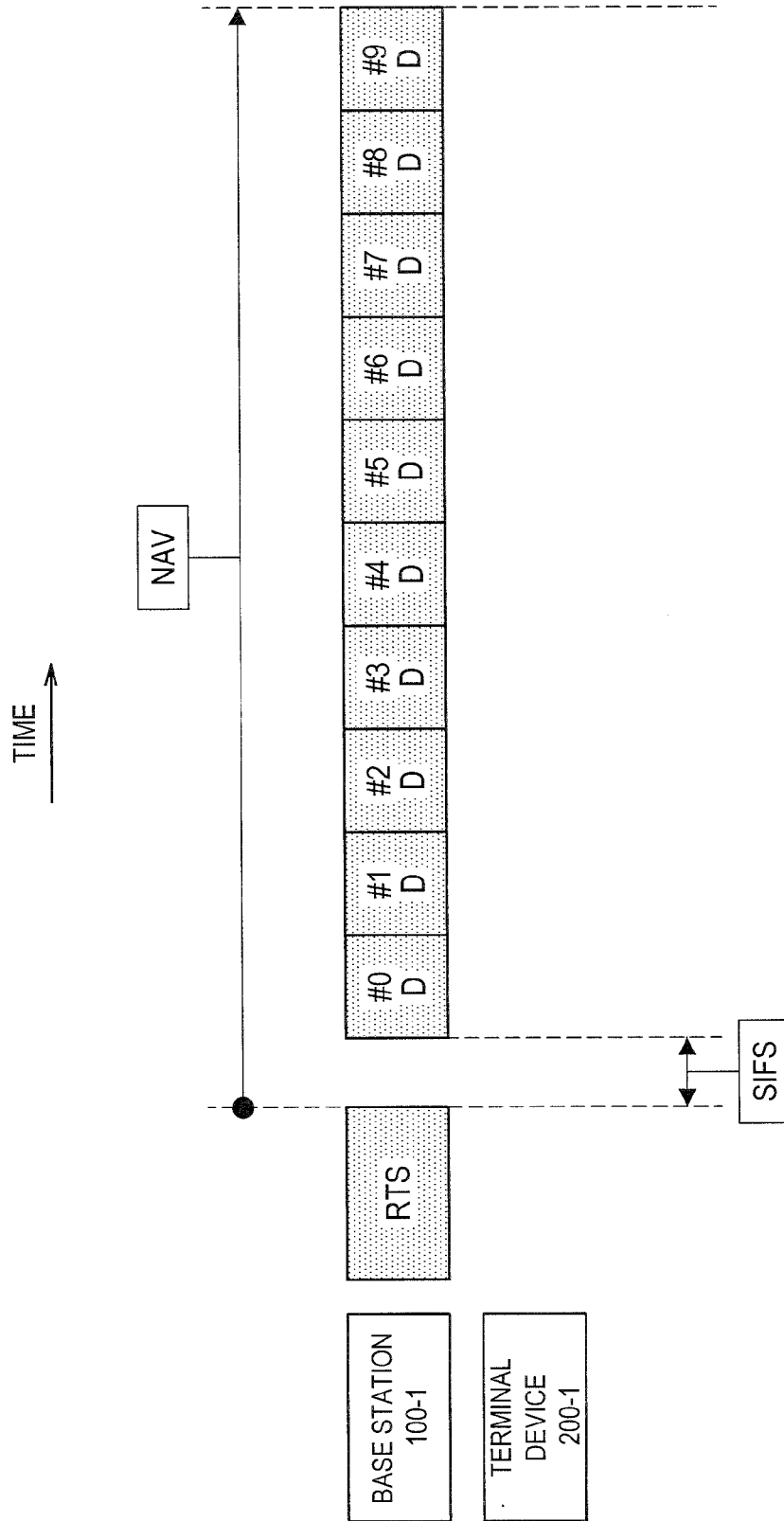


FIG. 10



BASE STATION
100-1

TERMINAL
DEVICE
200-1

FIG. 11

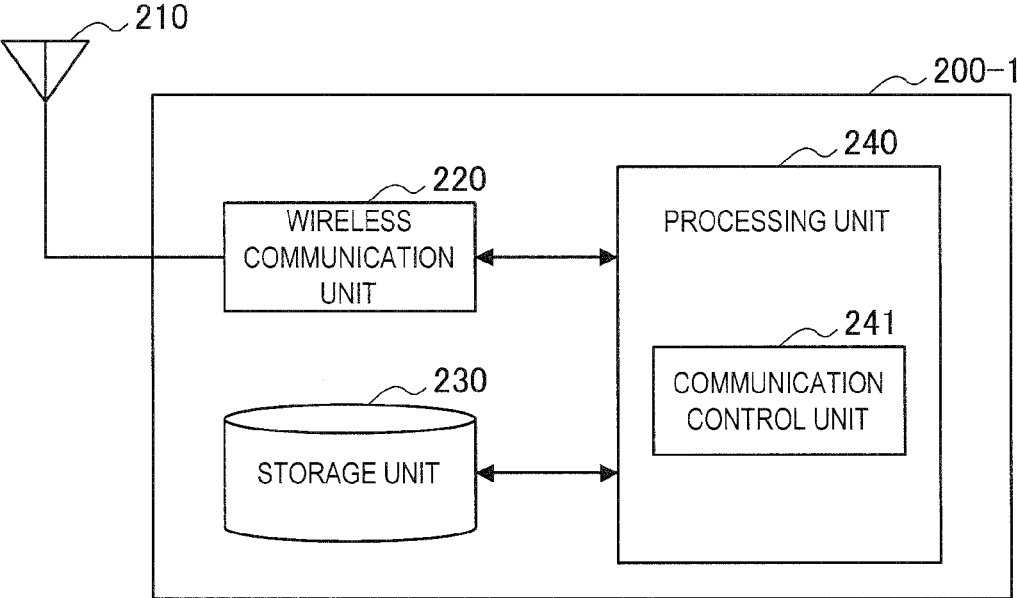


FIG. 12

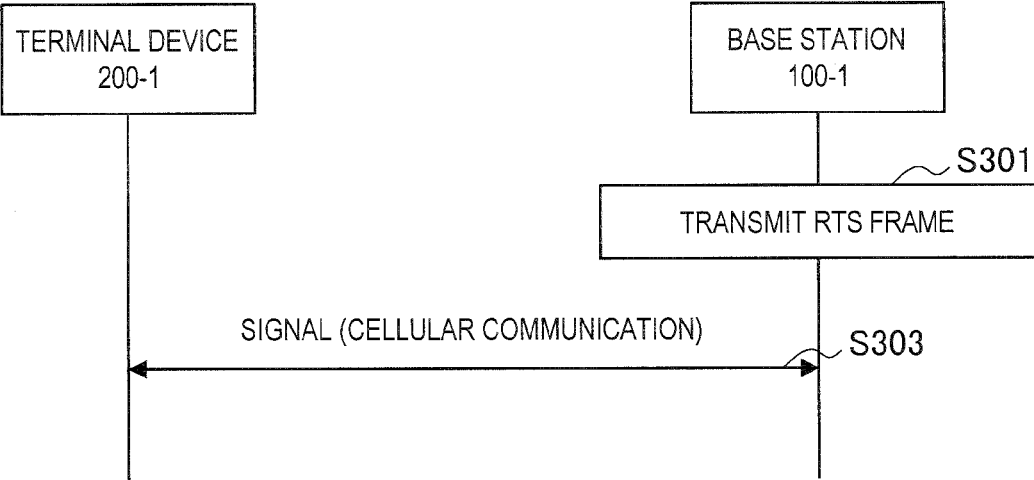


FIG. 13

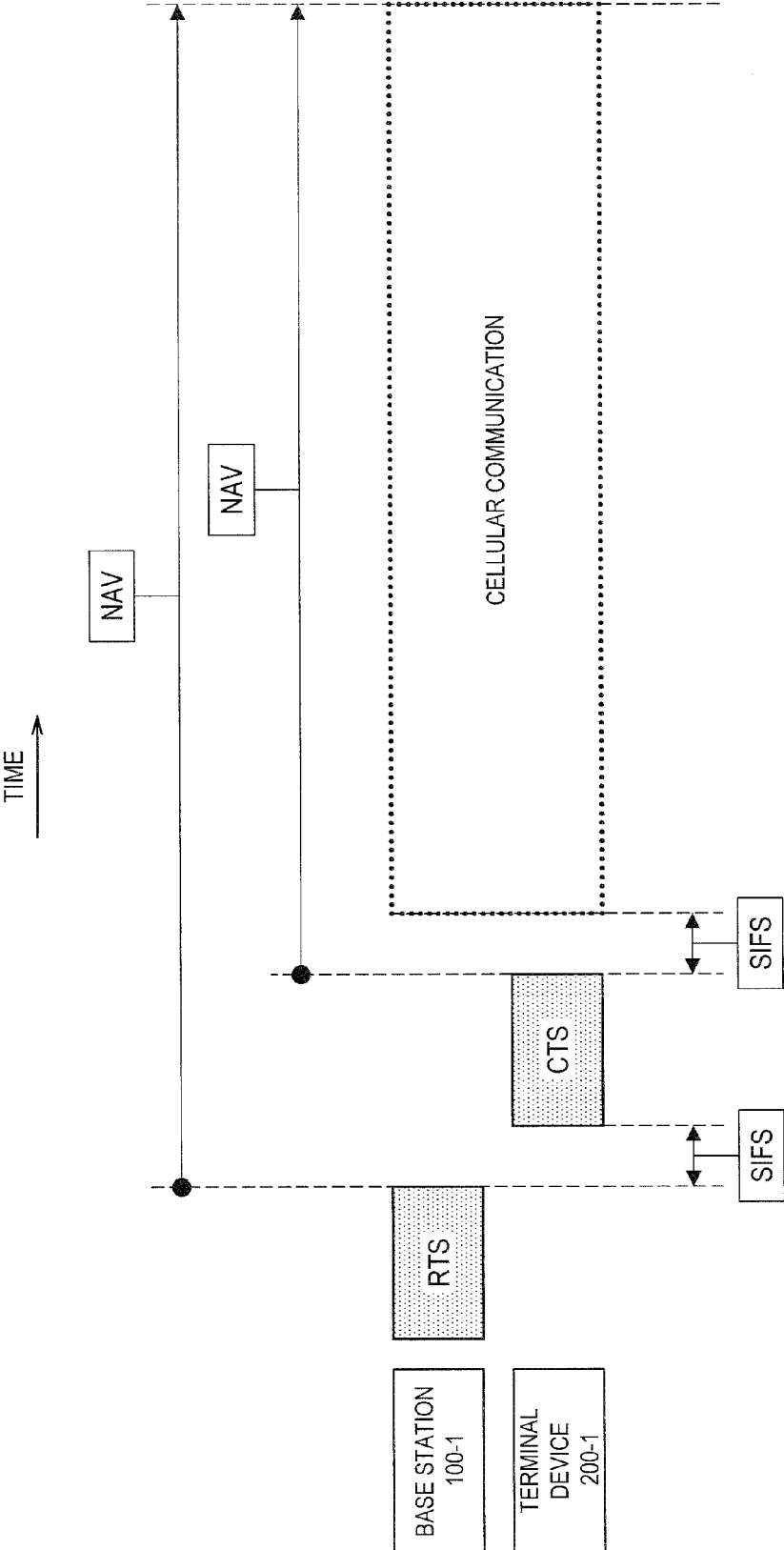


FIG. 14

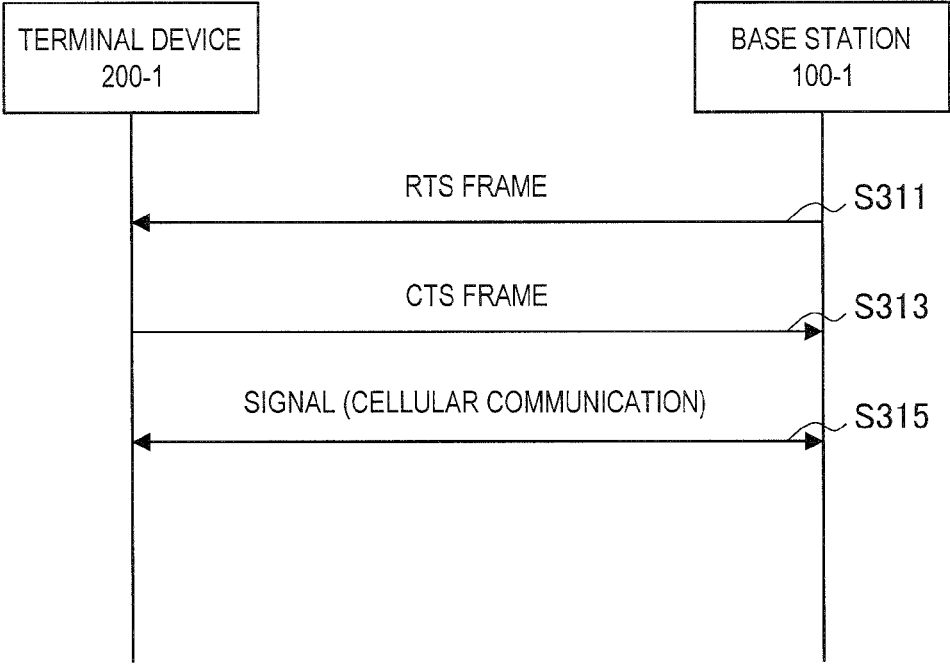


FIG. 15

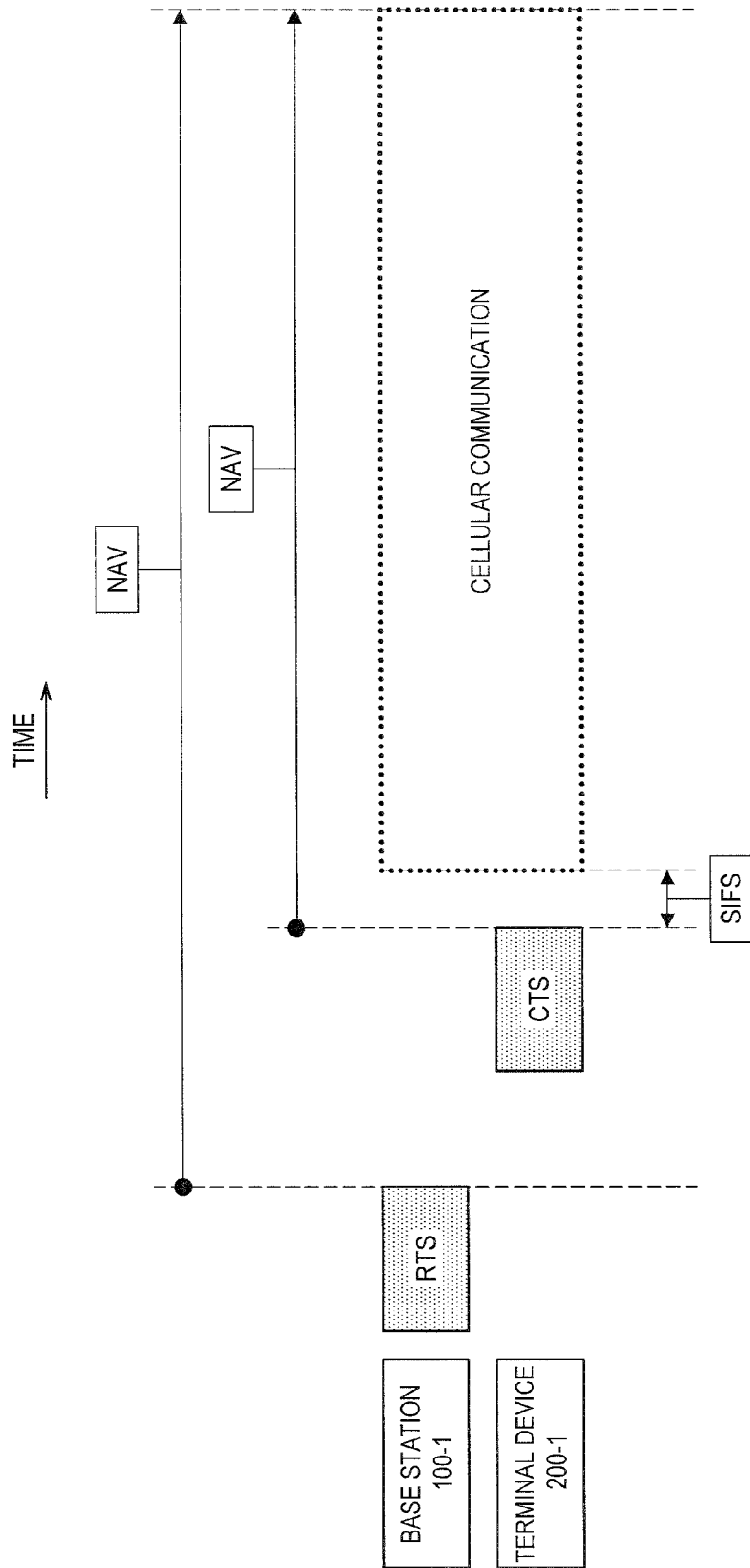


FIG. 16

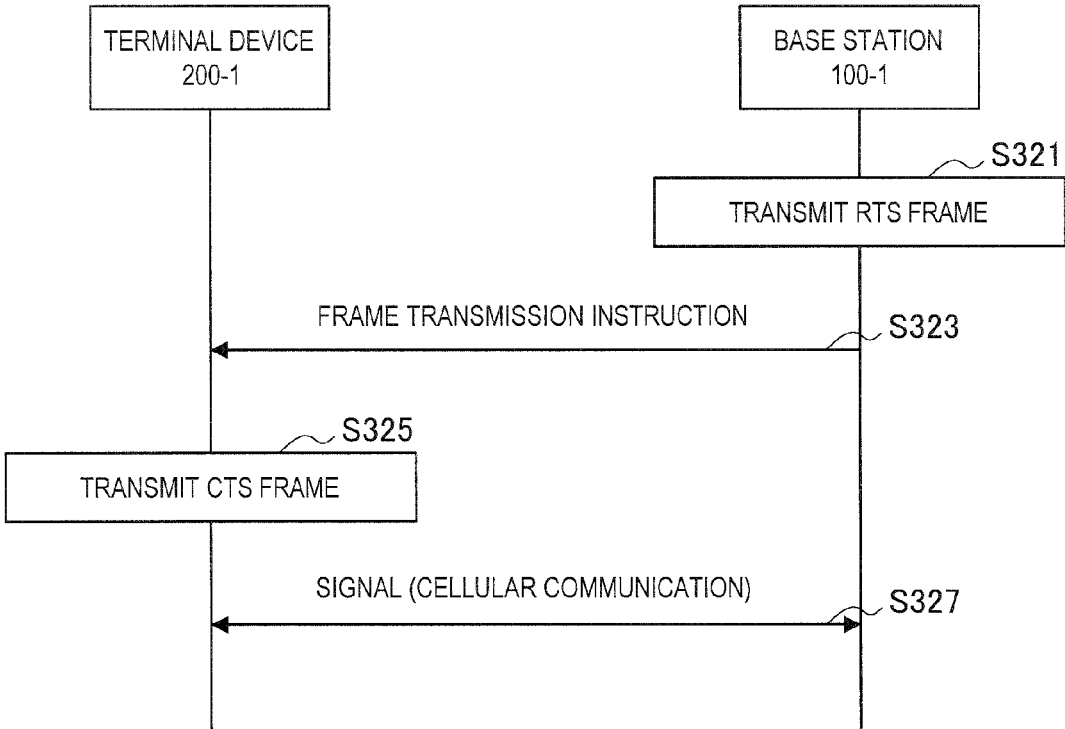


FIG. 17

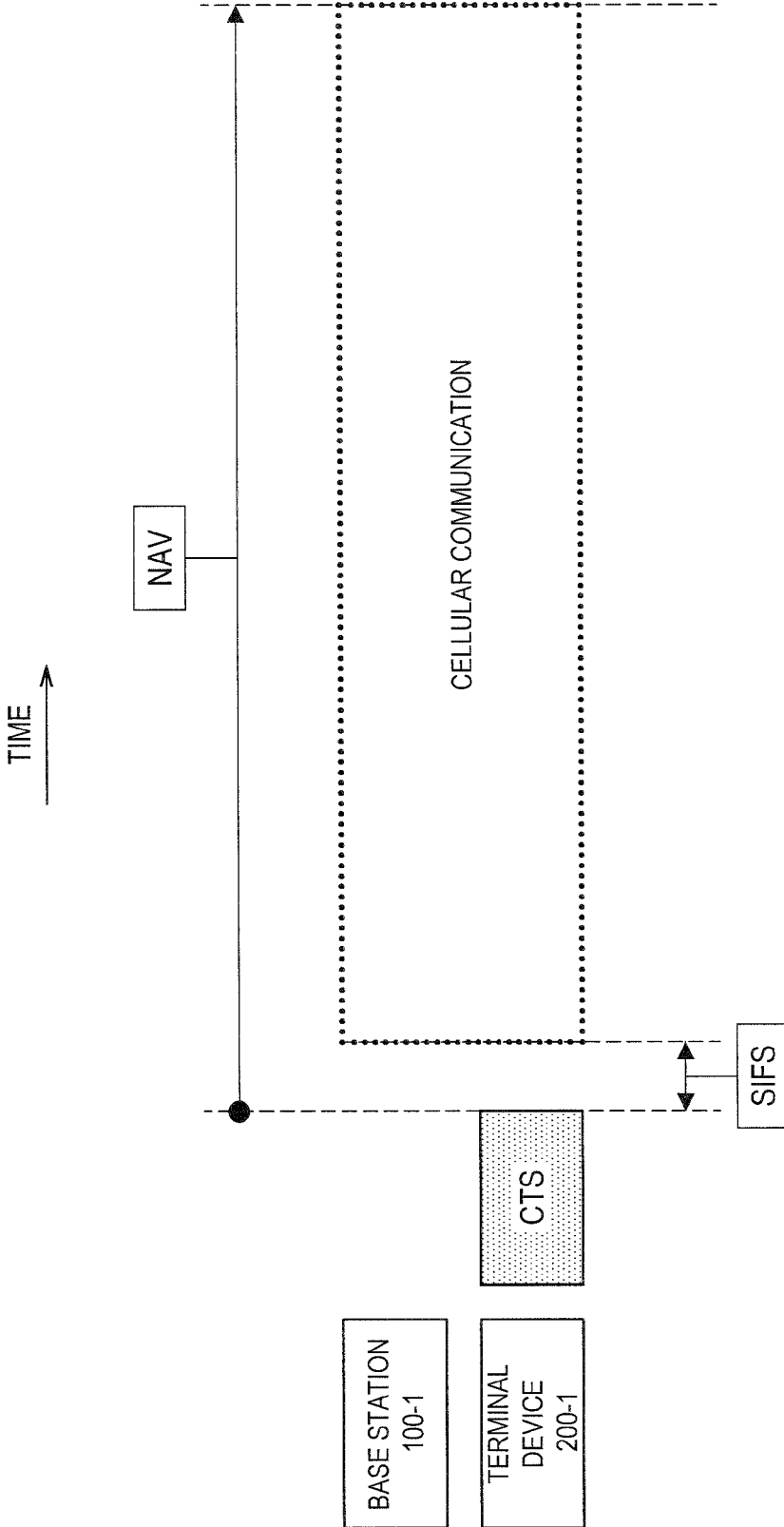


FIG. 18

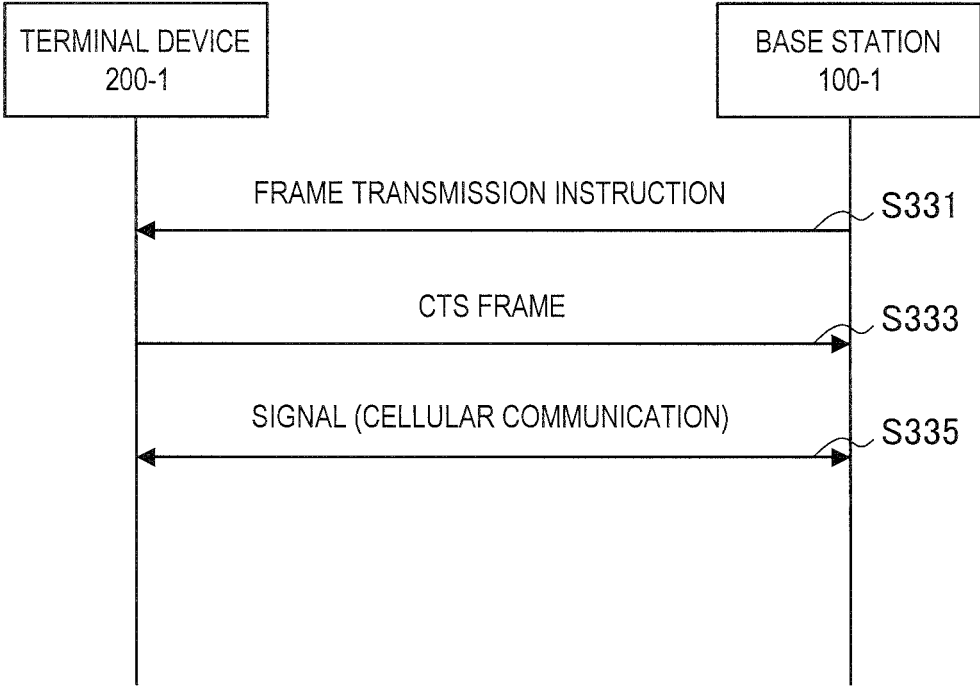


FIG. 19

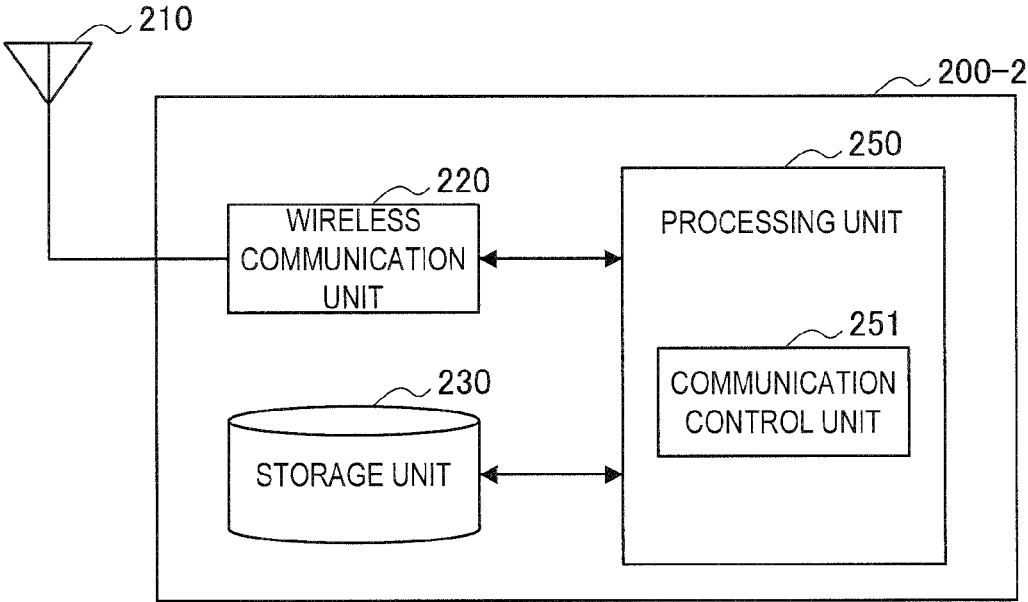


FIG. 20

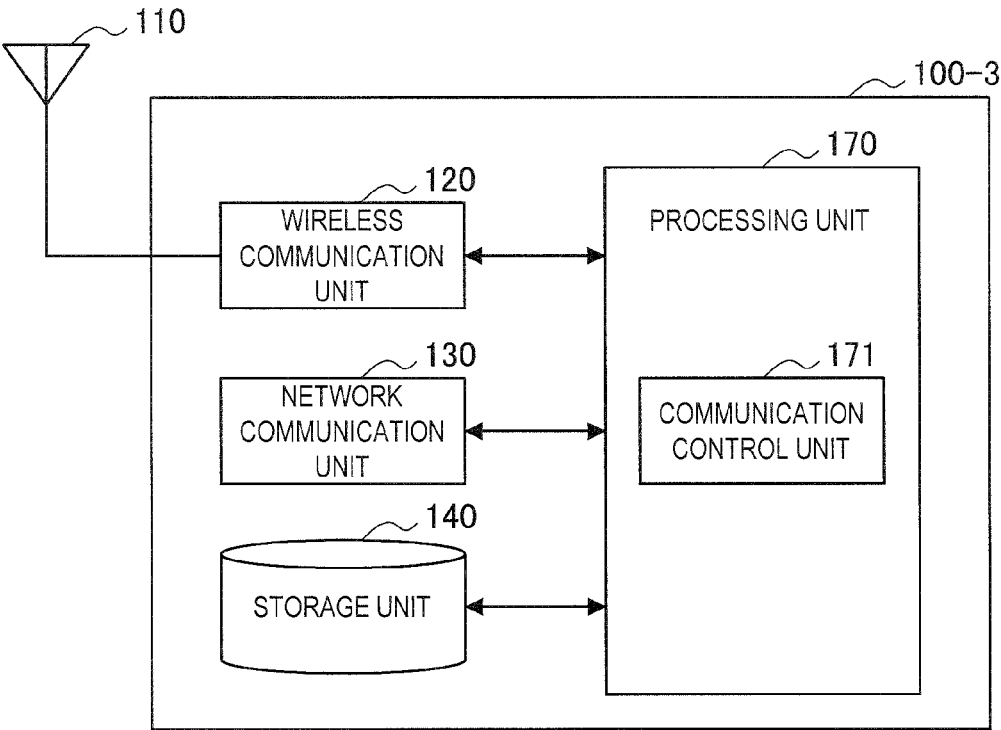


FIG. 21

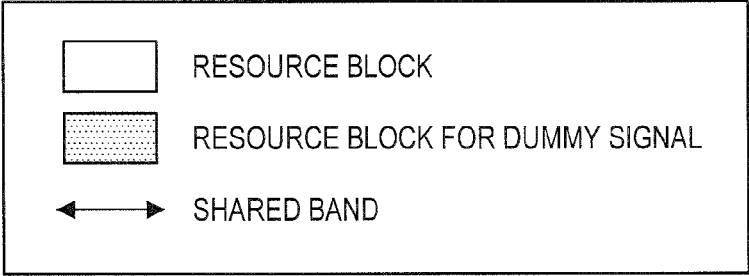
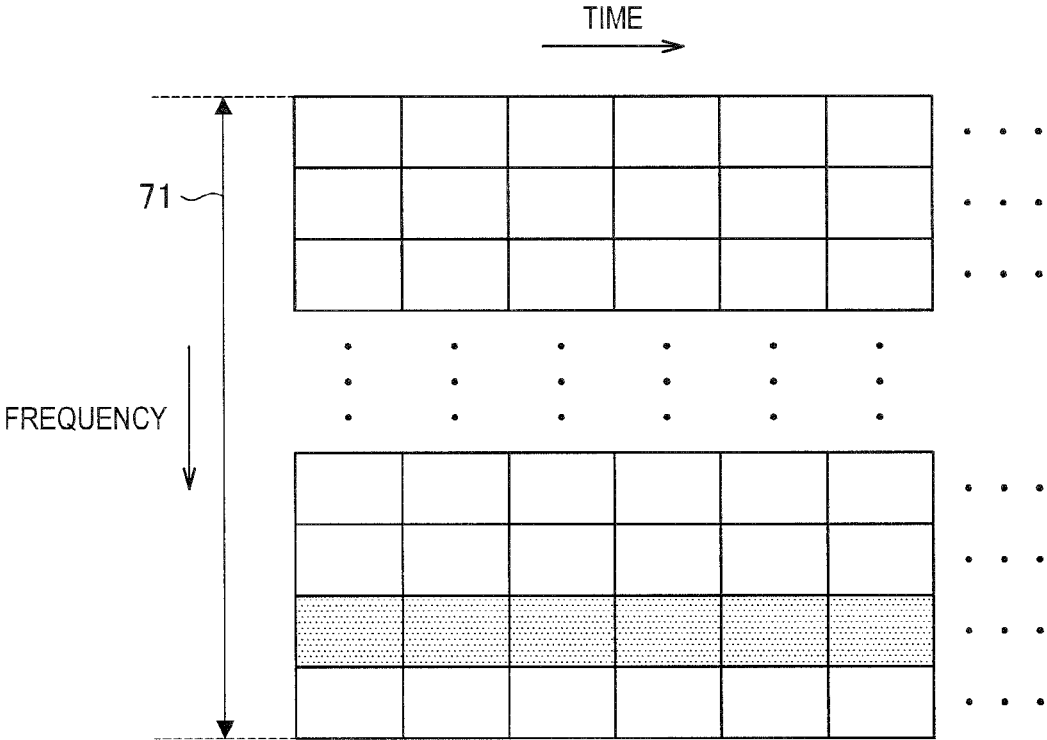
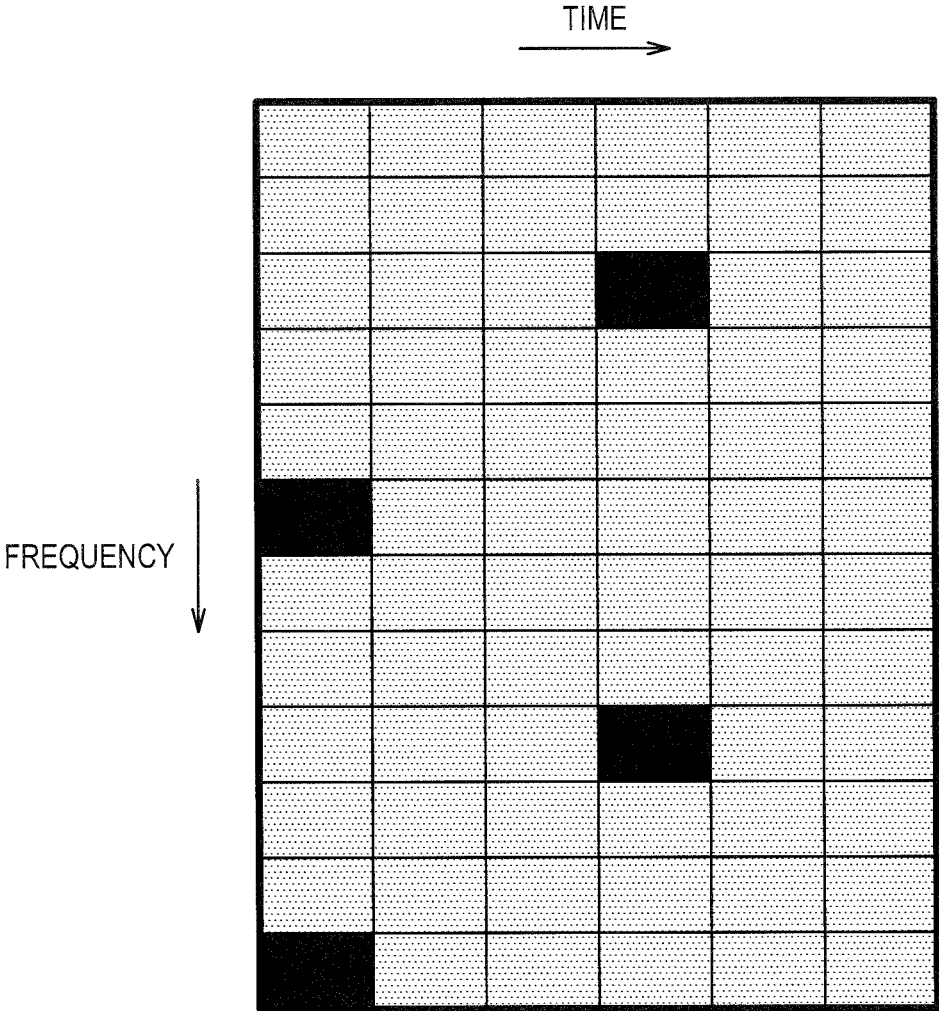


FIG. 22




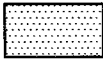

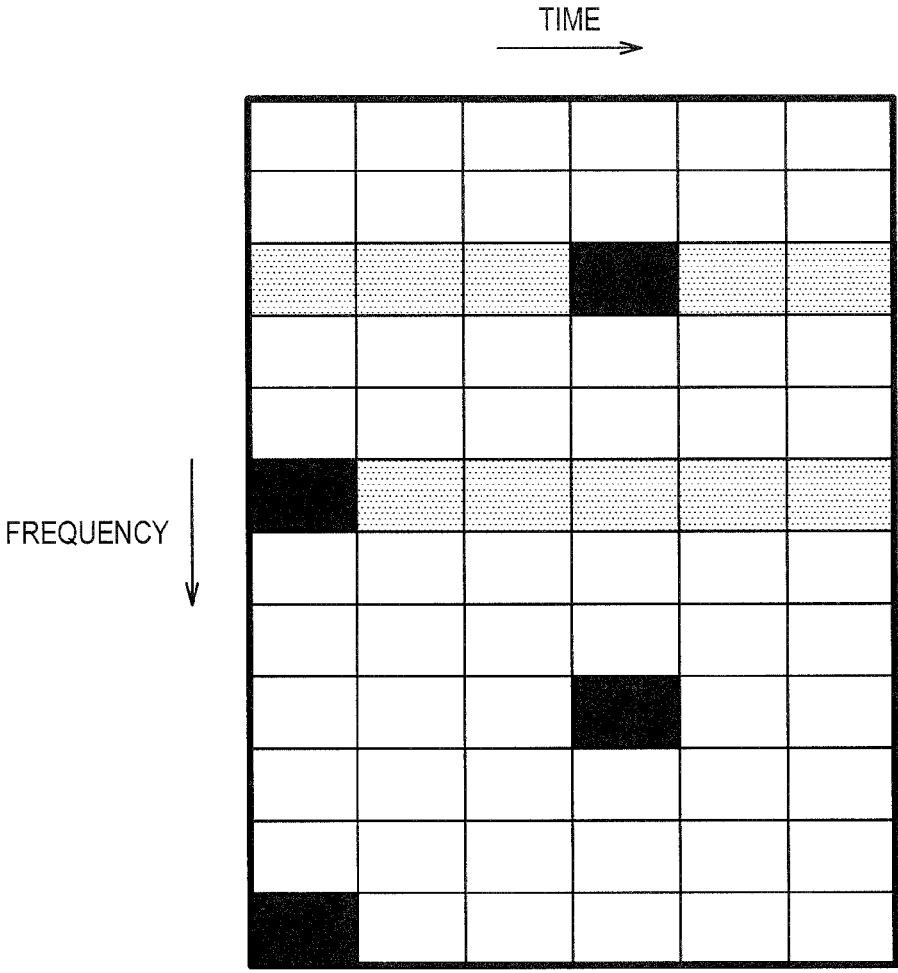
	RESOURCE ELEMENT FOR CRS
	RESOURCE ELEMENT FOR DUMMY SIGNAL
	RESOURCE BLOCK

FIG. 23







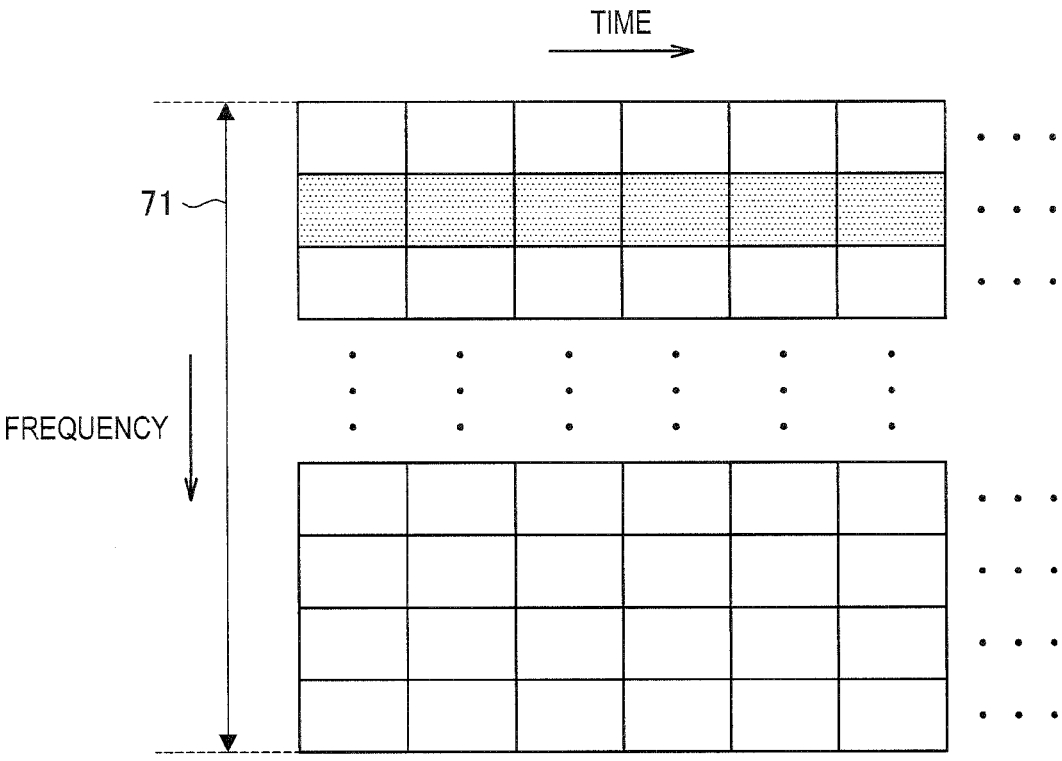
-  RESOURCE ELEMENT
-  RESOURCE ELEMENT FOR CRS
-  RESOURCE ELEMENT FOR DUMMY SIGNAL
-  RESOURCE BLOCK

FIG. 24



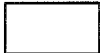


	RESOURCE BLOCK
	RESOURCE BLOCK FOR DUMMY SIGNAL
	SHARED BAND

FIG. 25

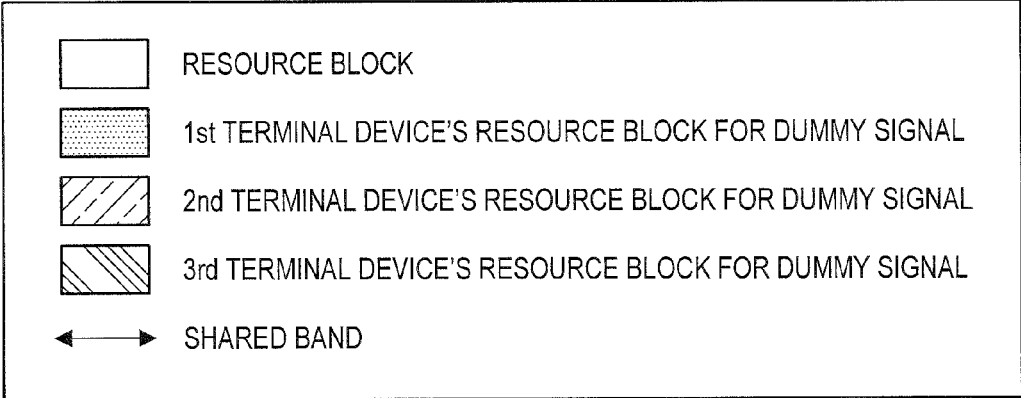
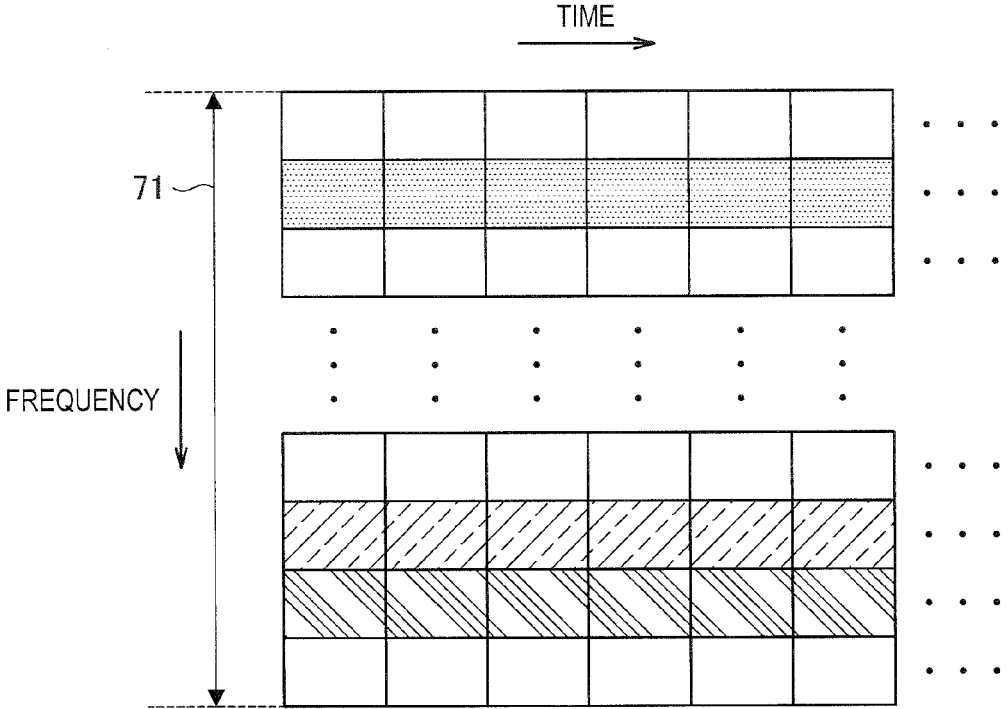


FIG. 26

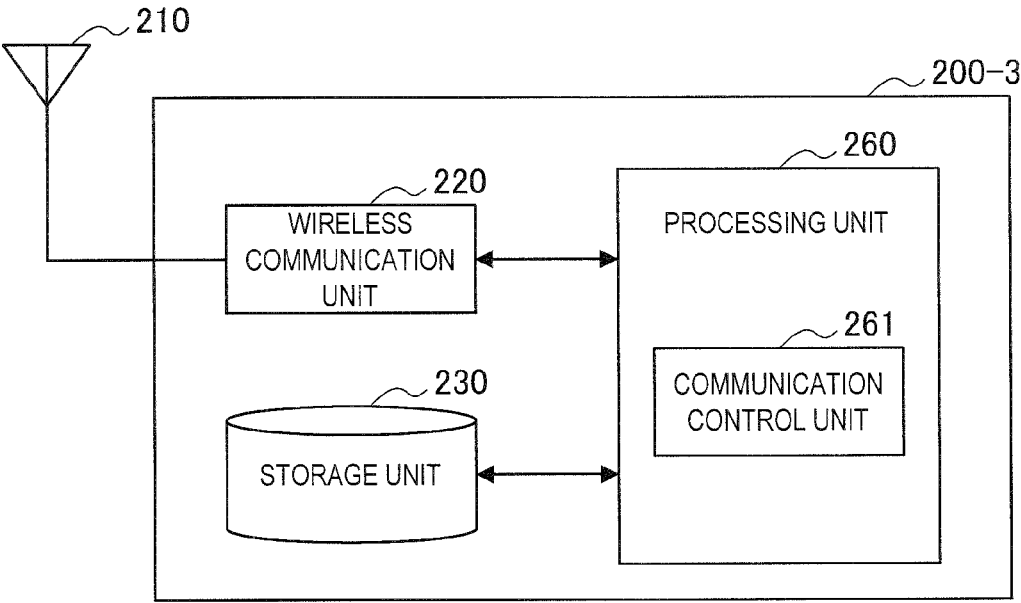


FIG. 27

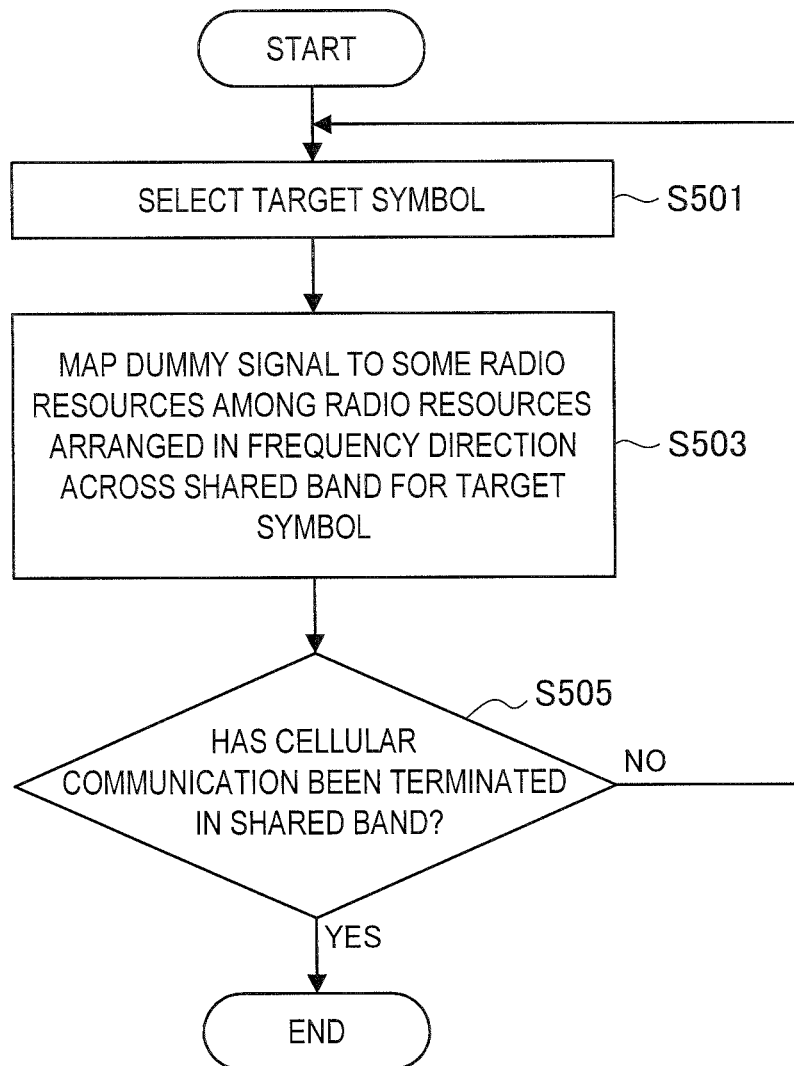


FIG. 28

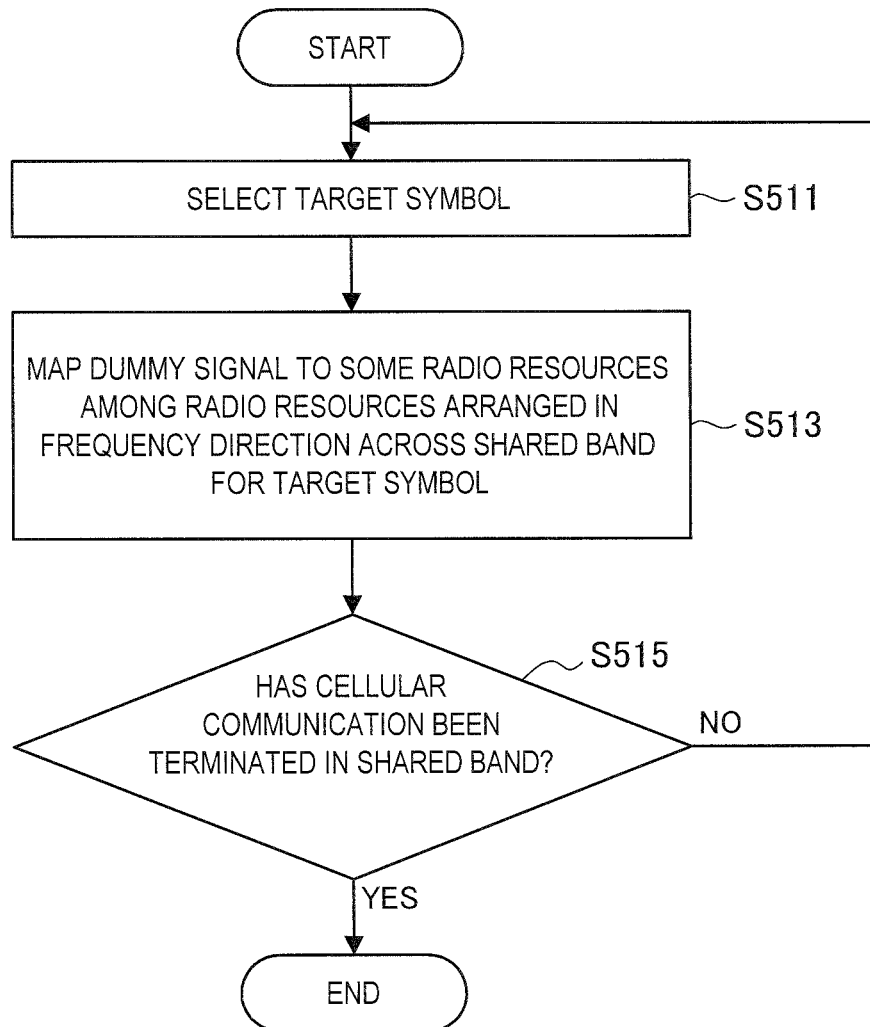
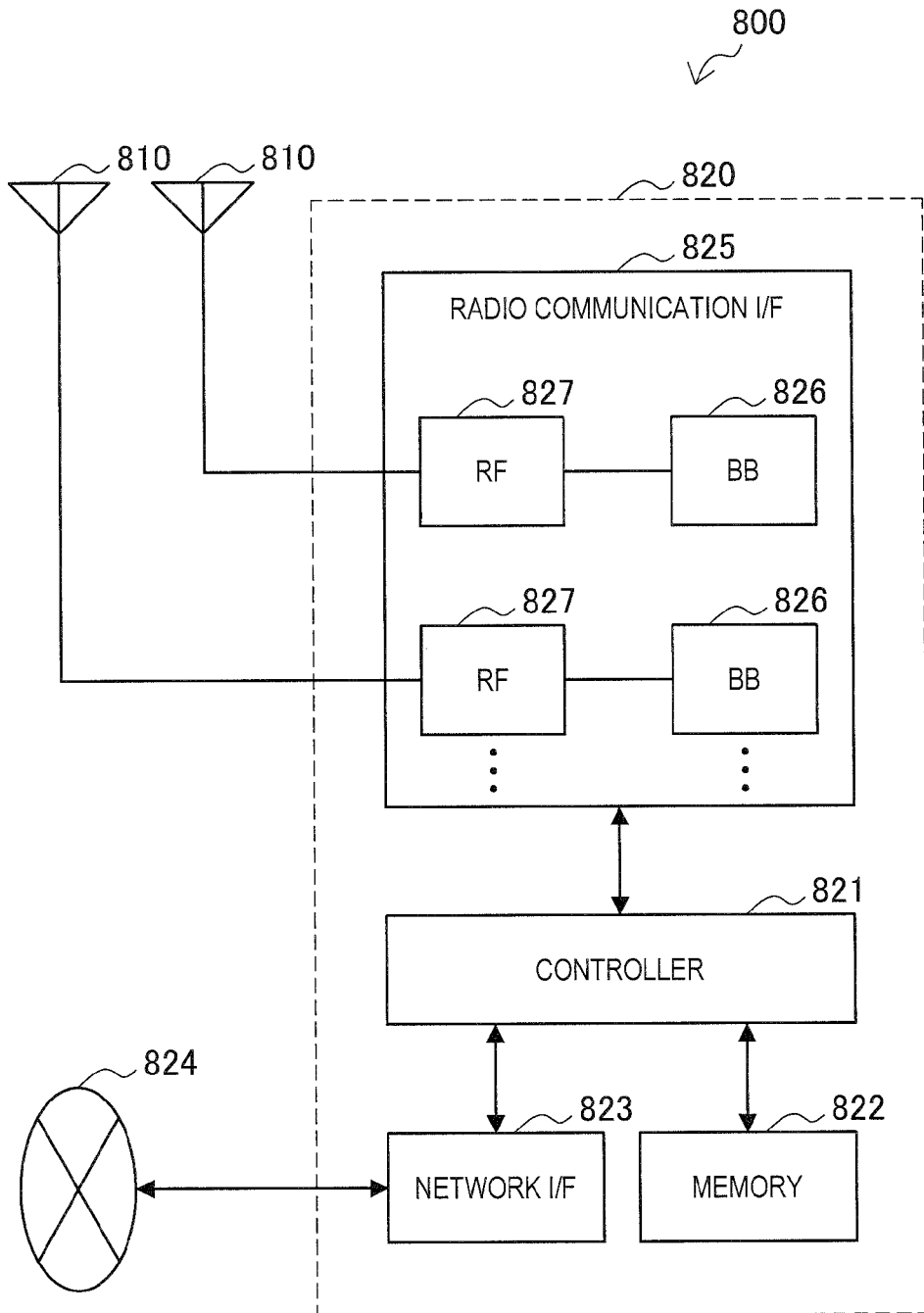


FIG. 29



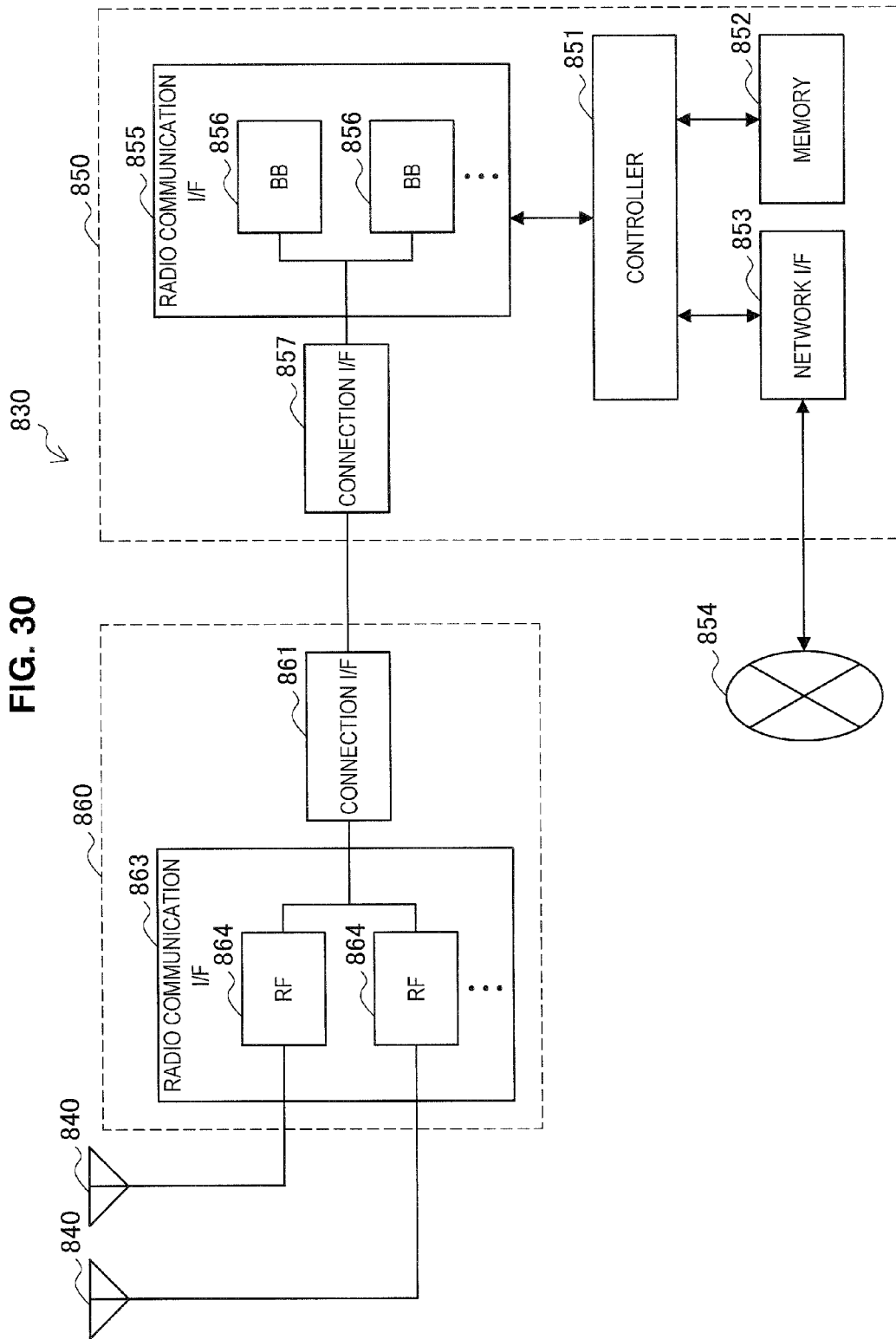


FIG. 31

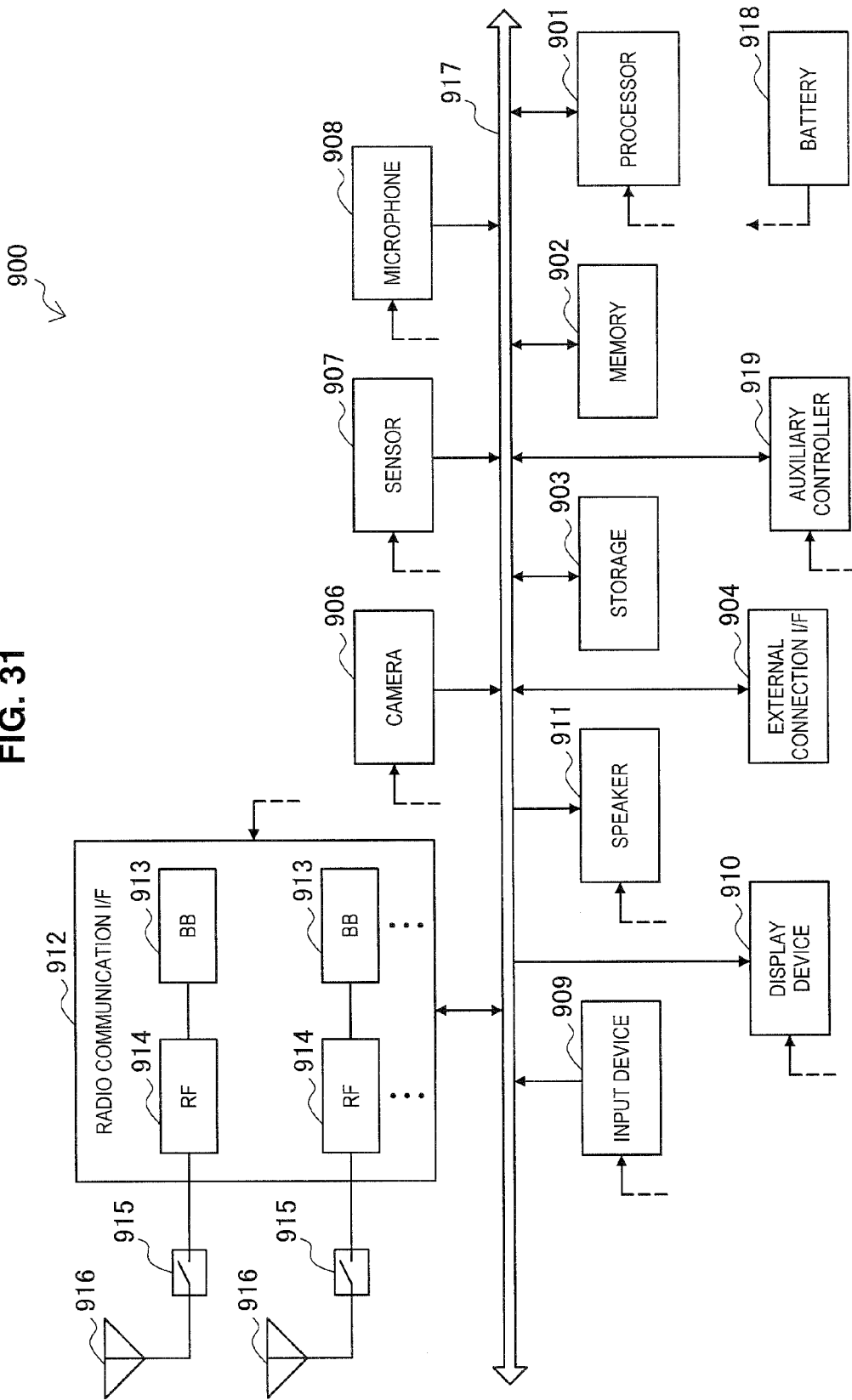
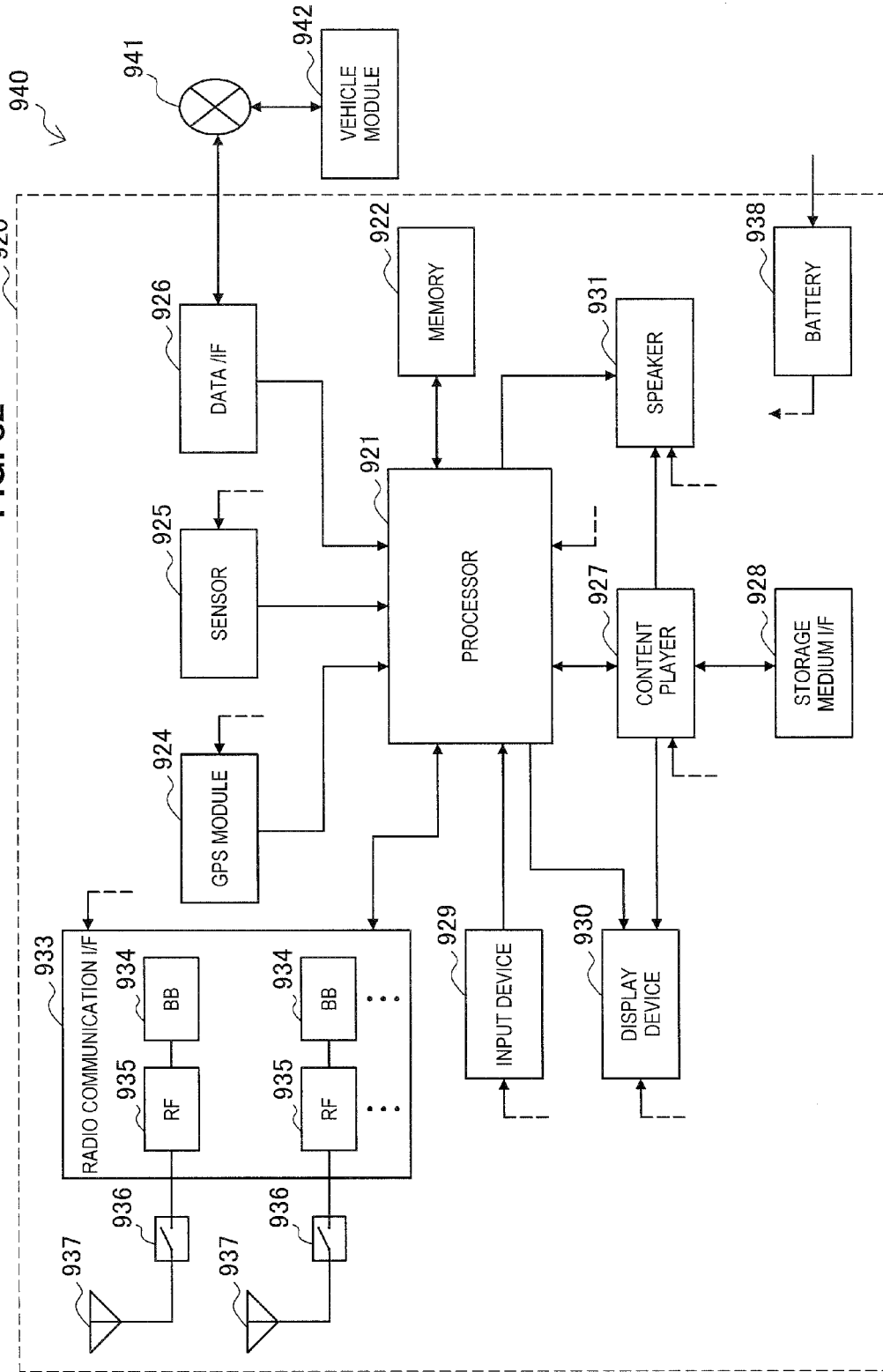


FIG. 32



DEVICE

TECHNICAL FIELD

[0001] The present disclosure relates to a device.

BACKGROUND ART

[0002] In the 3rd Generation Partnership Project (3GPP), various technologies for improving system throughput have been discussed. It may be said that a first shortcut for improving the system throughput is increasing a frequency to be used. In the 3GPP, the technology of carrier aggregation (CA) has been considered in Release 10 and Release 11. CA is a technology for improving the system throughput and a maximum data rate by aggregating component carriers (CCs) having a bandwidth of 20 MHz for use. A frequency band available as a CC must adopt the technology of such CA. Thus, a frequency band available for wireless communication of a cellular system is required.

[0003] For example, in Patent Literature 1, technology which enables a registered frequency band available for a registered provider and an unlicensed band available when a predetermined condition is satisfied to be used in addition to a dedicated frequency band allocated to each provider for exclusive use is disclosed.

CITATION LIST

Patent Literature

[0004] Patent Literature 1: JP 2006-094001A

SUMMARY OF INVENTION

Technical Problem

[0005] However, for example, when a frequency band to be used in other wireless communication (for example, wireless communication of a wireless local area network (LAN)) is also used in wireless communication of a cellular system, a variety of undesired results can be caused. That is, when a frequency band is shared between wireless communication of the cellular system and other wireless communication, a variety of undesired results can be caused.

[0006] As an example, when the above-mentioned frequency band is used in the above-mentioned cellular system, interference between the wireless communication of the above-mentioned cellular system and the other wireless communication (for example, wireless communication of the wireless LAN) is likely to occur in the above-mentioned frequency band. Thus, communication quality of the wireless communication of the above-mentioned cellular system and/or the above-mentioned other wireless communication can deteriorate.

[0007] Therefore, it is desirable to provide a mechanism which enables a frequency band shared between wireless communication of a cellular system and other wireless communication to be more appropriately used in the cellular system.

Solution to Problem

[0008] According to the present disclosure, there is provided a device including: a control unit configured to control a wireless communication device for performing wireless communication of a cellular system so that the wireless

communication device transmits a frame including duration information for setting a network allocation vector (NAV) using a frequency band shared between the wireless communication of the cellular system and wireless communication conforming to a wireless local area network (LAN) standard. The control unit controls a base station of the cellular system so that the wireless communication of the cellular system is performed using the frequency band in a period after the transmission of the frame.

[0009] Also, according to the present disclosure, there is provided a device including: a control unit configured to control a terminal device for performing wireless communication of a cellular system so that the terminal device transmits a frame including duration information for setting an NAV using a frequency band shared between the wireless communication of the cellular system and wireless communication conforming to a wireless LAN standard according to an instruction from a base station of the cellular system.

[0010] Also, according to the present disclosure, there is provided a device including: a control unit configured to control a wireless communication device for performing wireless communication of a cellular system so that the wireless communication device transmits a frame including duration information for setting an NAV using a frequency band shared between the wireless communication of the cellular system and wireless communication conforming to a wireless LAN standard. The control unit controls a terminal device for performing wireless communication of the cellular system so that the wireless communication of the cellular system is performed using the frequency band in a period after the transmission of the frame.

[0011] Also, according to the present disclosure, there is provided a device including: a control unit configured to control a wireless communication device for performing wireless communication of a cellular system so that the wireless communication device transmits a signal using a frequency band shared between the wireless communication of the cellular system and other wireless communication at any time.

Advantageous Effects of Invention

[0012] According to the above-described present disclosure, a frequency band shared between wireless communication of a cellular system and other wireless communication can be more appropriately used in the cellular system. Note that the effects described above are not necessarily limited, and along with or instead of the effects, any effect that is desired to be introduced in the present specification or other effects that can be expected from the present specification may be exhibited.

BRIEF DESCRIPTION OF DRAWINGS

[0013] FIG. 1 is an explanatory diagram illustrating a frame format of Institute of Electrical and Electronics Engineers (IEEE) 802.11.

[0014] FIG. 2 is an explanatory diagram illustrating a frame format of long-term evolution (LTE).

[0015] FIG. 3 is an explanatory diagram illustrating an example of a schematic configuration of a cellular system according to an embodiment of the present disclosure.

[0016] FIG. 4 is an explanatory diagram illustrating an example of a communication area of a wireless local area network (LAN) overlapping a small cell.

[0017] FIG. 5 is an explanatory diagram illustrating an example of a communication area of a wireless LAN overlapping a macro cell.

[0018] FIG. 6 illustrates an example of a configuration of a base station according to a first embodiment.

[0019] FIG. 7 is an explanatory diagram illustrating an example of a period in which cellular communication is performed using a shared band in the first embodiment.

[0020] FIG. 8 is an explanatory diagram illustrating an example of cellular communication when time division duplex (TDD) is adopted.

[0021] FIG. 9 is an explanatory diagram illustrating an example of cellular communication when frequency division duplex (FDD) is adopted.

[0022] FIG. 10 is an explanatory diagram illustrating another example of cellular communication when FDD is adopted.

[0023] FIG. 11 is a block diagram illustrating an example of a configuration of a terminal device according to the first embodiment.

[0024] FIG. 12 is a sequence diagram illustrating an example of a schematic flow of a process according to the first embodiment.

[0025] FIG. 13 is an explanatory diagram illustrating a period in which cellular communication is performed using a shared band in a first modified example of the first embodiment.

[0026] FIG. 14 is a sequence diagram illustrating an example of a schematic flow of a process according to the first modified example of the first embodiment.

[0027] FIG. 15 is an explanatory diagram illustrating a period in which cellular communication is performed using a shared band in a second modified example of the first embodiment.

[0028] FIG. 16 is a sequence diagram illustrating an example of a schematic flow of a process according to the second modified example of the first embodiment.

[0029] FIG. 17 is an explanatory diagram illustrating a period in which cellular communication is performed using a shared band in a third modified example of the first embodiment.

[0030] FIG. 18 is a sequence diagram illustrating an example of a schematic flow of a process according to the third modified example of the first embodiment.

[0031] FIG. 19 is a block diagram illustrating an example of a configuration of a terminal device according to the second embodiment.

[0032] FIG. 20 is a block diagram illustrating an example of a configuration of a base station according to a third embodiment.

[0033] FIG. 21 is an explanatory diagram illustrating an example of some resource blocks (RBs) in which a dummy signal is transmitted.

[0034] FIG. 22 is an explanatory diagram illustrating an example of a resource element (RE) in which a dummy signal is transmitted among some RBs.

[0035] FIG. 23 is an explanatory diagram illustrating an example of some REs in which a dummy signal is transmitted in each RB.

[0036] FIG. 24 is an explanatory diagram illustrating a first example of radio resources in which dummy signals are transmitted by a plurality of terminal devices.

[0037] FIG. 25 is an explanatory diagram illustrating a second example of radio resources in which dummy signals are transmitted by a plurality of terminal devices.

[0038] FIG. 26 is a block diagram illustrating an example of a configuration of a terminal device according to the third embodiment.

[0039] FIG. 27 is a flowchart illustrating an example of a schematic flow of a process by a base station according to the third embodiment.

[0040] FIG. 28 is a flowchart illustrating an example of a schematic flow of a process by the terminal device according to the third embodiment.

[0041] FIG. 29 is a block diagram illustrating a first example of a schematic configuration of an eNB.

[0042] FIG. 30 is a block diagram illustrating a second example of a schematic configuration of an eNB.

[0043] FIG. 31 is a block diagram illustrating an example of a schematic configuration of a smartphone.

[0044] FIG. 32 is a block diagram illustrating an example of a schematic configuration of a car navigation device.

DESCRIPTION OF EMBODIMENT(S)

[0045] Hereinafter, preferred embodiments of the present disclosure will be described in detail and with reference to the attached drawings. Note that, in this specification and the appended drawings, structural elements that have substantially the same function and structure are denoted with the same reference numerals, and repeated explanation of these structural elements is omitted.

[0046] Also, in the present description and drawings, a plurality of elements having substantially the same functional configuration may be distinguished from each other by each of the elements having a different alphabetical letter added to the end of the same reference numeral. For example, a plurality of elements having substantially the same functional configuration may be distinguished from each other as necessary, such as terminal devices 200A, 200B, and 200C. However, if it is not particularly necessary to distinguish each of a plurality of structural elements having substantially the same functional configuration, only the same reference numeral is assigned. For example, if it is not particularly necessary to distinguish between the terminal devices 200A, 200B, and 200C, they are simply referred to as the terminal device 200.

[0047] Also, the description will be given in the following order.

- [0048] 1. Introduction
- [0049] 2. Schematic configuration of system
- [0050] 3. First Embodiment
 - [0051] 3.1. Summary
 - [0052] 3.2. Configuration of base station
 - [0053] 3.3. Configuration of terminal device
 - [0054] 3.4. Flow of process
 - [0055] 3.5. First modified example
 - [0056] 3.6. Second modified example
 - [0057] 3.7 Third modified example
- [0058] 4. Second Embodiment
 - [0059] 4.1. Summary
 - [0060] 4.2. Configuration of base station
 - [0061] 4.3. Flow of process
- [0062] 5. Third Embodiment
 - [0063] 5.1. Summary
 - [0064] 5.2. Configuration of base station
 - [0065] 5.3. Configuration of terminal device

- [0066] 5.4. Flow of process
- [0067] 5.5. Modified example
- [0068] 6. Application example
- [0069] 6.1. Application example related to base station
- [0070] 6.2. Application example related to terminal device
- [0071] 7. Conclusion

1. INTRODUCTION

[0072] First, sharing of a frequency band, technology of wireless communication conforming to a wireless local area network (LAN) standard, and technology of wireless communication of a cellular system will be described with reference to FIGS. 1 and 2.

[0073] (Sharing of Frequency Band)

[0074] A frequency band available for the wireless communication of the cellular system is required. For example, a band of 5 GHz is considered as a frequency band for use in wireless communication of the cellular system (hereinafter referred to as “cellular communication”).

[0075] However, the band of 5 GHz is used in wireless communication conforming to the wireless LAN standard (hereinafter referred to as “wireless LAN communication”). Thus, when the cellular system uses the band of 5 GHz, for example, the band of 5 GHz is shared between cellular communication and wireless LAN communication. Specifically, for example, a frequency band of 5 GHz (for example, a channel of a wireless LAN) is used in the wireless LAN communication at a certain time and used in the cellular communication at another time. Thereby, frequency utilization efficiency of the band of 5 GHz is improved. Also, the wireless LAN standard includes Institute of Electrical and Electronics Engineers (IEEE) 802.11a, 11b, 11g, 11n, 11ac, and 11ad, etc. and these standards are characterized in that IEEE 802.11 is adopted for a media access control (MAC) layer.

[0076] Devices for performing wireless LAN communication are already widespread in the world. Thus, from the viewpoint of backward compatibility, a mechanism for sharing a frequency band between cellular communication and wireless LAN communication without changing an operation of the device for performing the wireless LAN communication is considered as the technology of Long Term Evolution (LTE) and is desired to be defined as a new standard of LTE. Also, a terminal device conforming to the above-mentioned new standard uses the shared frequency band, but a terminal device which does not conform to the above-mentioned new standard is considered as a terminal device not using the shared frequency band.

[0077] In LTE, LTE-Advanced, or a cellular system conforming to a communication standard equivalent thereto, the shared frequency band will be used as, for example, a component carrier (CC). Further, it is assumed that the frequency band of the cellular system is used as a primary component carrier (PCC) and the shared frequency band is used as a secondary component carrier (SCC). Also, a control signal and a data signal can be transmitted and received using a frequency band of the cellular system and the data signal can be transmitted and received using the shared frequency band.

[0078] (Technology of Wireless Communication Conforming to Wireless LAN Standard)

[0079] A frame format of IEEE 802.11 will be described as the technology of wireless communication conforming to

the wireless LAN standard with reference to FIG. 1. FIG. 1 is an explanatory diagram illustrating a frame format of IEEE 802.11.

[0080] In IEEE 802.11, a DATA frame and an acknowledgement (ACK) frame are basic frames. When the DATA frame is correctly received, the ACK frame is a frame which causes a transmitting side to know the success of reception of the DATA frame. Although wireless LAN communication can be performed only by the DATA frame and the ACK frame, two frames such as a request to send (RTS) frame and a clear to send (CTS) frame are generally further used.

[0081] Before the RTS frame is transmitted, each terminal device which performs the wireless LAN communication confirms that no signal is transmitted during a period referred to as a distributed coordination function (DCF) inter-frame space (DIFS). This is referred to as carrier sense. When terminal devices simultaneously start to transmit signals at a point in time at which the DIFS has elapsed, the signals may collide with each other. Thus, each terminal device waits for a backoff time randomly set for each terminal device and transmits a signal if no signal is transmitted for the backoff time.

[0082] Basically, the terminal device cannot transmit the signal while any signal is detected. However, because there is a hidden terminal problem, an RTS frame and a CTS frame including a duration field for setting a value referred to as a network allocation vector (NAV) are added. The NAV is set on the basis of a value included in the duration field. The terminal device setting the NAV avoids transmitting a signal during a period of the NAV.

[0083] First, a first terminal device for transmitting the DATA frame transmits the RTS frame. Then, another terminal device located around the first terminal device receives the RTS frame and acquires a value included in the duration field in the RTS frame. The other terminal device sets, for example, its own NAV to the above-mentioned acquired value and avoids transmitting a signal during the period of the NAV. For example, the period of the NAV is a period from the end of the RTS frame to the end of the ACK frame.

[0084] Also, a second terminal device for receiving the DATA frame transmits the CTS frame after only a short inter-frame space (SIFS) from the end of the RTS frame according to the reception of the RTS frame. Then, another terminal device located around the above-mentioned second terminal device receives the CTS frame and acquires a value included in the duration field in the CTS frame. The other terminal device sets, for example, its own NAV to the above-mentioned acquired value and avoids transmitting a signal during the period of the NAV. The period of the NAV is a period from the end of the CTS frame to the end of the ACK frame. Thereby, for example, it is possible to prevent the other terminal device (that is, a hidden terminal for the above-mentioned first terminal device) close to the above-mentioned second terminal device without being close to the above-mentioned first terminal device from transmitting a signal during communication of the above-mentioned first terminal device and the above-mentioned second terminal device.

[0085] Also, the RTS frame includes a frame control field, a reception address field, a transmission address field, and a frame check sequence (FCS) in addition to the duration field. Also, the CTS frame includes a frame control field, a reception address field, and an FCS in addition to the duration field.

[0086] Also, the DIFS and the DIFS in the standard of the IEEE 802.11 series have, for example, the following lengths.

TABLE 1

	802.11b	802.11g	802.11a	802.11n	802.11ac
SIFS	10 us	10 us	16 us	16 us	16 us
DIFS	50 us	28 us	34 us	34 us	34 us

[0087] (Technology of Wireless Communication of Cellular System)

[0088] (a) Frame Format

[0089] The frame format of LTE will be described with reference to FIG. 2. FIG. 2 is an explanatory diagram illustrating the frame format of LTE.

[0090] First, a unit of time such as a radio frame is used in LTE. One radio frame is 10 ms. Each radio frame is identified by a system frame number (SFN) which is any one of 0 to 1023.

[0091] The radio frame includes 10 sub-frames identified by #0 to #9. Each sub-frame is 1 ms. Further, each sub-frame includes two slots and each slot includes, for example, seven orthogonal frequency division multiplexing (OFDM) symbols.

[0092] That is, each sub-frame includes 14 OFDM symbols. Also, the frame format illustrated in FIG. 2 is a frame format of a downlink and the frame format of an uplink includes a single carrier frequency division multiple access (SC-FDMA) symbol in place of an OFDM symbol.

[0093] (b) Carrier Aggregation

[0094] Component Carriers

[0095] With carrier aggregation in Release 10, up to a maximum of five CCs are aggregated for use by user equipment (UE). Each CC is a band with a maximum width of 20 MHz. Carrier aggregation includes a case in which successive CCs in the frequency direction are used, and a case in which separated CCs in the frequency direction are used. With carrier aggregation, the CCs to be used may be set for each UE.

[0096] PCC and SCC

[0097] In carrier aggregation, one of the multiple CCs used by a UE is a special CC. This special CC is called the primary component carrier (PCC). Also, the remaining CCs among the multiple CCs are called secondary component carriers (SCCs). The PCC may be different depending on the UE.

[0098] Since the PCC is the most important CC among the multiple CCs, it is desirable for the PCC to be the CC with the most stable communication quality.

[0099] Note that in actual practice, which CC to treat as the PCC depends on the implementation.

[0100] The SCC is added to the PCC. In addition, an existing SCC that has been added may also be removed. Note that changing an SCC is conducted by removing an existing SCC and adding a new SCC.

[0101] PCC Determination Method and Changing Method

[0102] When a UE connection is initially established and the status of the UE goes from Radio Resource Control (RRC) Idle to RRC Connected, the CC that the UE used during the establishment of the connection becomes the PCC for that UE. More specifically, a connection is established through a connection establishment procedure. At this point, the status of the UE goes from RRC Idle to RRC Connected.

Also, the CC used in the procedure becomes the PCC for the above UE. Note that the above procedure is a procedure initiated from the UE side.

[0103] Additionally, PCC changing is conducted by a handover between frequencies. More specifically, if a handover is specified in a connection reconfiguration procedure, a PCC handover is conducted, and the PCC is changed. Note that the above procedure is a procedure initiated from the network side.

[0104] Adding SCC

[0105] As discussed above, the SCC is added to the PCC. As a result, the SCC is associated with the PCC. In other words, the SCC is subordinate to the PCC. SCC addition may be conducted through a connection reconfiguration procedure. Note that this procedure is a procedure initiated from the network side.

[0106] Removing SSC

[0107] As discussed above, an SCC may be removed. SSC removal may be conducted through a connection reconfiguration procedure. Specifically, a specific SCC specified in a message is removed. Note that the above procedure is a procedure initiated from the network side.

[0108] In addition, the removal of all SCCs may be conducted through a connection re-establishment procedure.

[0109] Special role of PCC

[0110] The connection establishment procedure, the transmitting and receiving of non-access stratum (NAS) signaling, and the transmitting and receiving of uplink control signals on the physical uplink control channel (PUCCH) are conducted only by the PCC, and not by the SCCs.

[0111] In addition, the detection of a radio link failure (RLF) and a subsequent connection re-establishment procedure are also conducted only by the PCC, and not by the SCCs.

[0112] (Conditions of Backhauling for Carrier Aggregation)

[0113] For example, an ACK of a downlink signal on an SCC is transmitted by the PUCCH of the PCC. Since the ACK is used for the retransmission of data by the evolved Node B (eNB), a delay of the ACK is not acceptable. Consequently, when a first eNB using a CC that acts as the PCC for a UE is different from a second eNB using a CC that acts as an SCC for the UE, a backhaul delay of approximately 10 ms between the first eNB and the second eNB is desirable.

2. SCHEMATIC CONFIGURATION OF CELLULAR SYSTEM

[0114] Next, a schematic configuration of a cellular system **1** according to an embodiment of the present disclosure will be described with reference to FIGS. **3** to **5**. FIG. **3** is an explanatory diagram illustrating an example of the schematic configuration of the cellular system **1** according to the embodiment of the present disclosure. Referring to FIG. **3**, the system **1** includes a base station **100** and a terminal device **200**. The cellular system **1** is, for example, LTE, LTE-Advanced, or a system conforming to a communication standard equivalent thereto.

[0115] (Base Station **100**)

[0116] The base station **100** performs wireless communication (cellular communication) of the cellular system **1**. That is, the base station **100** performs wireless communication with the terminal device **200**. For example, the base station **100** performs wireless communication with the ter-

minal device **200** located within a cell **10** which is a communication area of the base station **100**. Specifically, for example, the base station **100** transmits a downlink signal to the terminal device **200** and receives an uplink signal from the terminal device **200**.

[0117] As an example, the base station **100** is a small base station and the cell **10** is a small cell. As another example, the base station **100** may be a macro base station and the cell **10** may be a macro cell.

[0118] (Terminal Device **200**)

[0119] The terminal device **200** performs wireless communication (cellular communication) of the cellular system.

[0120] For example, the terminal device **200** performs wireless communication with the base station **100**. For example, when the terminal device **200** is located within the cell **10** of the base station **100**, the terminal device **200** performs wireless communication with the base station **100**. Specifically, for example, the terminal device **200** receives the downlink signal from the base station **100** and transmits the uplink signal to the base station **100**.

[0121] Also, the terminal device **200** can perform wireless communication with another terminal device (for example, another terminal device **200** or the like). For example, the terminal device **200** can perform device-to-device (D2D) communication. Also, the terminal device **200** can perform wireless communication within a localized network (LN) formed by the terminal device.

[0122] Also, the terminal device **200** may perform other wireless communication. For example, the terminal device **200** may perform wireless communication (wireless LAN communication) conforming to the wireless LAN standard.

[0123] (Frequency Band to be Used)

[0124] In wireless communication (that is, cellular communication) of the cellular system **1**, the frequency band of the cellular system **1** is used. The frequency band is, for example, a band allocated to a provider of the cellular system **1**, and can be referred to as a licensed band.

[0125] In particular, in the embodiment of the present disclosure, a frequency band to be used in other wireless communication is also used in the cellular communication. That is, a frequency band shared between the cellular communication and the above-mentioned other wireless communication (hereinafter referred to as a “shared band”) is also used in the cellular communication. The above-mentioned other wireless communication is, for example, wireless communication conforming to a wireless LAN standard (that is, wireless LAN communication). Also, the above-mentioned shared band is, for example, a channel of a wireless LAN. As an example, the above-mentioned shared band is a channel of 20 MHz.

[0126] (Other Wireless Communication)

[0127] A communication area of the above-mentioned other wireless communication may be located within the cell **10**. That is, the cell **10** can overlap a communication area of the above-mentioned other wireless communication.

[0128] For example, the other wireless communication is wireless LAN communication and a communication area of the wireless LAN can be located within the cell **10**. That is, the cell **10** can overlap the communication area of the wireless LAN. Hereinafter, in this regard, a specific example will be described with reference to FIGS. **4** and **5**.

[0129] FIG. **4** is an explanatory diagram illustrating an example of a communication area of a wireless LAN overlapping a small cell. Referring to FIG. **4**, the base station **100**

which is a small base station and the terminal device **200** are illustrated. Further, an access point **30** of a wireless LAN and a terminal device **50** for performing wireless LAN communication are located around the base station **100** and the terminal device **200**. A communication area **40** of the access point **30** overlaps the cell **10** which is a small cell.

[0130] FIG. **5** is an explanatory diagram illustrating an example of a communication area of a wireless LAN overlapping a macro cell. Referring to FIG. **5**, the base station **100** which is a macro base station and the terminal device **200** are illustrated. Further, the access point **30** of a wireless LAN and the terminal device **50** for performing wireless LAN communication are located around the base station **100** and the terminal device **200**. The communication area **40** of the access point **30** overlaps the cell **10** which is a macro cell.

[0131] Also, the wireless LAN communication can include wireless communication conforming to a wireless LAN standard between terminal devices which perform the wireless LAN communication in addition to wireless communication between the wireless LAN access point and the terminal device (which perform wireless LAN communication). As an example, the wireless LAN communication can also include wireless communication according to Wi-Fi Direct.

[0132] The cellular system **1** according to the embodiment of the present disclosure has been described above. Also, the cellular system **1** can include a plurality of base stations **100** as well as one base station **100**. Also, the cellular system **1** can include another device in addition to the base station **100** and the terminal device **200**. For example, the cellular system **1** can include core network nodes (for example, a mobility management entity (MME), a serving gateway (S-GW), and a packet data network gateway (P-GW), etc.).

3. FIRST EMBODIMENT

[0133] Next, the first embodiment of the present disclosure will be described with reference to FIGS. **6** to **19**.

3.1. Summary

[0134] First, the summary of the first embodiment will be described.

[0135] Problem According to First Embodiment

[0136] In the wireless LAN standard, carrier sense multiple access with collision avoidance (CSMA/CA) is adopted and each of devices for performing wireless LAN communication (that is, wireless conforming to the wireless LAN standard) (hereinafter referred to as a “wireless LAN device”) transmits a signal by its own determination according to the CSMA/CA.

[0137] For example, a frequency band used in the wireless LAN communication (for example, a channel of a wireless LAN) is also used in cellular communication. That is, a frequency band is shared between the cellular communication and the wireless LAN communication. In this case, for example, even while the above-mentioned frequency band is used in cellular communication, the wireless LAN device can transmit a signal using the above-mentioned frequency band by its own determination according to the CSMA/CA. Thus, interference between the cellular communication and the wireless LAN communication occurs in the above-mentioned frequency band, and communication quality of

the above-mentioned cellular communication and/or wireless LAN communication is likely to deteriorate.

[0138] Therefore, it is desirable to provide a mechanism which enables the frequency band shared between the cellular communication and the other wireless communication to be more appropriately used in the cellular system. More specifically, it is desirable to provide a mechanism capable of preventing a frequency band shared between the cellular communication and the wireless LAN communication from being used in the wireless LAN communication while the above-mentioned frequency band is used in the cellular communication.

[0139] Characteristics of First Embodiment

[0140] According to the first embodiment, through control by the base station 100-1, the wireless communication device for performing the cellular communication transmits a frame including duration information for setting an NAV using the frequency band shared between the cellular communication and the wireless LAN communication. Through control by the base station 100-1, the cellular communication is performed using the above-mentioned frequency band in the period after the transmission of the above-mentioned frame. Also, the above-mentioned wireless communication device is the base station 100-1 or a terminal device 200-1.

[0141] Thereby, for example, while the frequency band shared between the cellular communication and the wireless LAN communication is used in the cellular communication, the above-mentioned frequency band can be prevented from being used in wireless LAN communication.

3.2. Configuration of Base Station

[0142] Next, an example of the configuration of a base station 100-1 according to the first embodiment will be described with reference to FIGS. 6 to 10. FIG. 6 is a block diagram illustrating an example of the configuration of the base station 100-1 according to the first embodiment. Referring to FIG. 6, the base station 100-1 is equipped with an antenna unit 110, a wireless communication unit 120, a network communication unit 130, a storage unit 140, and a processing unit 150.

[0143] (Antenna Unit 110)

[0144] The antenna unit 110 emits a signal output by the wireless communication unit 120 into space as a radio wave. Additionally, the antenna unit 110 converts a radio wave from space into a signal, and outputs the signal to the wireless communication unit 120.

[0145] (Wireless Communication Unit 120)

[0146] The wireless communication unit 120 transmits and receives signals. For example, the wireless communication unit 120 transmits a downlink signal to a terminal device 200-1 positioned within the cell 10, and receives an uplink signal from the terminal device 200-1 positioned within the cell 10.

[0147] For example, the wireless communication unit 120 transmits and receives a signal using the frequency band of the cellular system 1. Also, particularly, in the embodiment of the present disclosure, the wireless communication unit 120 transmits and receives a signal using the frequency band shared between the cellular communication and the other wireless communication (for example, wireless LAN communication) (that is, a shared band).

[0148] (Network Communication Unit 130)

[0149] The network communication unit 130 communicates with other nodes. For example, the network communication unit 130 communicates with core network nodes (for example, MME, S-GW, P-GW, etc.). Also, the network communication unit 130 communicates with another base station 100-1.

[0150] (Storage Unit 140)

[0151] The storage unit 140 temporarily or permanently stores programs and data for the operation of the base station 100-1.

[0152] (Processing Unit 150)

[0153] The processing unit 150 provides various functions of the base station 100-1. The processing unit 150 includes a communication control unit 151. Also, the processing unit 150 can further include another component in addition to the communication control unit 151.

[0154] (Communication Control Unit 151)

[0155] (a) Frame Transmission Using Shared Band

[0156] The communication control unit 151 controls a wireless communication device for performing cellular communication so that the above-mentioned wireless communication device transmits a frame including duration information for setting the NAV using a frequency band shared between the cellular communication and wireless LAN communication (that is, a shared band).

[0157] Wireless Communication Device

[0158] For example, the above-mentioned wireless communication device includes the base station 100-1. That is, the communication control unit 151 controls the base station 100-1 so that the base station 100-1 transmits the above-mentioned frame using the above-mentioned shared band.

[0159] Specifically, for example, the communication control unit 151 triggers the transmission of a frame including duration information for setting the NAV. Then, the processing unit 160 (the communication control unit 151 or another constituent element) generates a frame including duration information for setting the NAV. Also, for example, the processing unit 160 (the communication control unit 151 or another constituent element) generates a signal of a physical layer of the above-mentioned frame according to scrambling, encoding, interleaving, symbol mapping, and/or modulation, etc. and causes the wireless communication unit 120 to transmit the signal.

[0160] According to the transmission of the above-mentioned frame by the above-mentioned base station 100-1, for example, it is possible to cause the wireless LAN device positioned within a region (for example, a cell 10) around the base station 100-1 to receive the above-mentioned frame.

[0161] Frame

[0162] For example, the above-mentioned frame has a duration field and includes the above-mentioned duration information in the duration field.

[0163] As an example, the above-mentioned frame is an RTS frame. As another example, the above-mentioned frame may be a CTS frame. As still another example, the above-mentioned frame may be another type of frame similar to the RTS frame and the CTS frame.

[0164] Duration Information

[0165] As described above, the above-mentioned duration information is information for setting the NAV. For example, the above-mentioned duration information indicates a duration. Also, the duration is a period after the transmission of the above-mentioned frame and covers a period in which the cellular communication is performed using the above-men-

tioned shared band. For example, the duration is determined by the communication control unit **151**.

[0166] According to the transmission of the frame including such duration information, for example, it is possible to cause the wireless LAN device for receiving the frame to set the NAV to cover the period in which the cellular communication is performed using the above-mentioned shared band.

[0167] Consequently, the use of the above-mentioned shared band by the wireless LAN device can be prevented during the period in which the cellular communication is performed using the above-mentioned shared band.

[0168] Also, the duration indicated by the above-mentioned duration information may cover a part of the above-mentioned period in which the cellular communication is performed using the above-mentioned shared band. An additional frame including the duration information for setting the NAV may be transmitted through control by the communication control unit **151** at any timing after the transmission of the above-mentioned frame. Also, another additional frame may be transmitted at any timing after the transmission of the additional frame. One or more additional frames may be transmitted at different timings as described above through control by the communication control unit **151**. Every time an additional frame is transmitted, the wireless LAN device can receive the additional frame and update the NAV on the basis of the duration information included in the additional frame. As a result, the above-mentioned time in which the cellular communication is performed using the above-mentioned shared band can be covered according to the duration information included in the above-mentioned frame and the above-mentioned one or more additional frames. Also, according to this technique, for example, it is possible to further lengthen a period in which the above-mentioned shared band is used in the cellular communication.

[0169] Timing of Transmission

[0170] The above-mentioned frame is transmitted, for example, at a timing at which a period in which no signal is transmitted using the above-mentioned shared band becomes a sum of a DIFS and a backoff time. For example, the communication control unit **151** controls the above-mentioned frame to start to be transmitted as described above.

[0171] Also, the above-mentioned frame may start to be transmitted before the period in which no signal is transmitted using the above-mentioned shared band becomes the DIFS. Thereby, for example, it is possible to more reliably transmit the above-mentioned frame using the above-mentioned shared band. Further, the above-mentioned frame may start to be transmitted after the period in which no signal is transmitted using the above-mentioned shared band is longer than an SIFS (but before the period becomes the DIFS). Thereby, for example, the collision of a signal of the above-mentioned frame with a signal of wireless LAN communication can be avoided.

[0172] (b) Cellular Communication Using Shared Band

[0173] The communication control unit **151** controls the base station **100-1** so that the cellular communication is performed using the above-mentioned shared band in the period after the transmission of the above-mentioned frame.

[0174] Period

[0175] Period Covered by Duration Information

[0176] As described above, for example, the above-mentioned duration information included in the above-mentioned frame indicates the duration. Also, the duration is the period after the transmission of the above-mentioned frame and covers the period in which the cellular communication is performed using the above-mentioned shared band. In other words, the above-mentioned period after the transmission of the above-mentioned frame is a period which is covered by the duration indicated by the duration information included in the above-mentioned frame.

[0177] Start Time-Point of Period

[0178] For example, the above-mentioned period after the transmission of the above-mentioned frame is a period which starts from a point in time at which the SIFS has elapsed from an end time-point of transmission of the above-mentioned frame. Thereby, for example, it is possible to avoid the collision of a signal of the above-mentioned frame with a signal of the wireless LAN communication. Also, thereby, for example, it is possible to further lengthen a time in which the above-mentioned shared band is used in the cellular communication.

[0179] Length of Period

[0180] For example, the above-mentioned period after the transmission of the above-mentioned frame is a period of one or more radio frames of the cellular system **1**. Thereby, for example, the cellular communication can be enabled using the above-mentioned shared band.

Specific Example

[0181] FIG. 7 is an explanatory diagram illustrating an example of a period in which cellular communication is performed using a shared band in the first embodiment. Referring to FIG. 7, first, the base station **100-1** transmits an RTS frame. The base station **100-1** starts cellular communication with the terminal device **200-1** using the shared band at a point in time at which the SIFS has elapsed from an end time-point of transmission of the RTS frame. Also, the base station **100-1** terminates the cellular communication before the passage of the period of the NAV set according to the RTS frame.

[0182] Also, no ACK frame is transmitted in the example of FIG. 7, but an ACK frame may be transmitted before the passage of the period of the above-mentioned NAV. In this case, the cellular communication may be terminated before the transmission start of the ACK frame. This is also applied to FIGS. **8, 9, 10, 13, 15, 17,** and **20** which will be described below as well as FIG. 7.

[0183] Also, FIG. 7 is not Intended to Describe a Length of the Period and it should be noted that the period in which the cellular communication is performed using the shared band can be greater than the length illustrated in FIG. 7 in comparison to the length of the RTS frame and the length of the SIFS. This is applied to FIGS. **8, 9, 10, 13, 15, 17,** and **20** to be described below as well as FIG. 7.

[0184] Duplex Operation

[0185] In the cellular system **1**, TDD and FDD are adopted as the duplex operation. That is, the duplex operation of the cellular system **1** is the TDD or FDD.

[0186] TDD

[0187] As a first example, the TDD is adopted as the duplex operation in the cellular system **1**. That is, the duplex operation of the cellular system **1** is the TDD. In this case, the above-mentioned shared band is used as a band for both a downlink and an uplink in the cellular system **1**. Herein-

after, an example of the cellular communication when the TDD is adopted will be described with reference to FIG. 8.

[0188] FIG. 8 is an explanatory diagram illustrating an example of cellular communication when the TDD is adopted. Referring to FIG. 8, for example, in a downlink subframe within a period in which the cellular communication is performed using a shared band, the base station 100-1 transmits a signal to the terminal device 200-1 using the shared band, and the terminal device 200-1 receives the signal. Also, in an uplink subframe within the above-mentioned period, the terminal device 200-1 transmits a signal to the base station 100-1 using the above-mentioned shared band, and the base station 100-1 receives the signal.

[0189] Also, cellular communication of only one radio frame is illustrated in the example of FIG. 8, but, of course, cellular communication of two or more frames may be performed. This is also applied to FIGS. 9 and 10 which will be described below as well as FIG. 8.

[0190] FDD

[0191] As a second example, the FDD is adopted as the duplex operation in the cellular system 1. That is, the duplex operation of the cellular system 1 is the FDD.

[0192] For example, a partial band included in the above-mentioned shared band in the cellular system 1 is used as a downlink band and another partial band included in the above-mentioned shared band is used as an uplink band. Hereinafter, an example of cellular communication when the FDD is adopted will be described with reference to FIG. 9.

[0193] FIG. 9 is an explanatory diagram illustrating an example of cellular communication when the FDD is adopted. Referring to FIG. 9, for example, within a period in which the cellular communication is performed using a shared band, the base station 100-1 transmits a signal to the terminal device 200-1 using a partial band of the shared band as the downlink band, and the terminal device 200-1 receives the signal. Also, within the above-mentioned period, the terminal device 200-1 transmits a signal to the base station 100-1 using another partial band of the above-mentioned shared band as the uplink band and the base station 100-1 receives the signal.

[0194] Also, two shared bands may be used in place of using the partial band of the shared band as the downlink band and using the other partial band of the shared band as the uplink band. In this case, in the cellular system 1, one of the two shared bands may be used as the downlink band and the other of the two shared bands may be used as the uplink band.

[0195] Also, the shared band may be used as one of the downlink band and the uplink band. For example, the shared band may be used as the downlink band in the cellular system 1. The frequency band of the cellular system 1 may be used as the uplink band corresponding to the above-mentioned shared band. That is, an uplink control signal associated with the shared band may be transmitted to the base station 100-1 by the terminal device 200-1 using the frequency band of the cellular system 1. Hereinafter, in this regard, a specific example will be described with reference to FIG. 10.

[0196] FIG. 10 is an explanatory diagram illustrating another example of cellular communication when the FDD is adopted. Referring to FIG. 10, for example, within a period in which the cellular communication is performed using the shared band, the base station 100-1 may transmit a signal to the terminal device 200-1 using the shared band

as the downlink band, and the terminal device 200 may receive the signal. Also, an uplink control signal associated with the shared band may be transmitted to the base station 100-1 by the terminal device 200-1 using the frequency band of the cellular system 1.

[0197] By using the shared band as the downlink band, for example, a hidden terminal problem can be reduced. Specifically, for example, because the terminal device 200-1 does not transmit an uplink signal using the above-mentioned shared band, interference to wireless LAN communication of the wireless LAN device positioned in the periphery of the terminal device 200-1 is suppressed.

3.3. Configuration of Terminal Device

[0198] Next, an example of a configuration of the terminal device 200-1 according to the first embodiment will be described with reference to FIG. 11. FIG. 11 is a block diagram illustrating the example of the configuration of the terminal device 200-1 according to the first embodiment. Referring to FIG. 11, the terminal device 200-1 includes an antenna unit 210, a wireless communication unit 220, a storage unit 230, and a processing unit 240.

[0199] (Antenna Unit 210)

[0200] The antenna unit 210 emits a signal output by the wireless communication unit 220 into space as a radio wave. Additionally, the antenna unit 210 converts a radio wave from space into a signal, and outputs the signal to the wireless communication unit 220.

[0201] (Wireless Communication Unit 220)

[0202] The wireless communication unit 220 transmits and receives a signal. For example, the wireless communication unit 220 receives a downlink signal from the base station 100-1 and transmits an uplink signal to the base station 100-1 when the terminal device 200-1 is located within the cell 10.

[0203] For example, the wireless communication unit 220 transmits and receives a signal using a frequency band of the cellular system 1. Also, particularly, in the embodiment of the present disclosure, the wireless communication unit 220 transmits and receives a signal using a frequency band shared between cellular communication and other wireless communication (for example, wireless LAN communication) (that is, a shared band).

[0204] (Storage Unit 230)

[0205] The storage unit 230 temporarily or permanently stores programs and data for the operation of the terminal device 200-1.

[0206] (Processing Unit 240)

[0207] The processing unit 240 provides various functions of the terminal device 200-1. The processing unit 240 includes a communication control unit 241. Also, the processing unit 240 can further include other components in addition to the communication control unit 241.

[0208] (Communication Control Unit 241)

[0209] The communication control unit 241 controls the terminal device 200-1.

3.4. Flow of Process

[0210] Next, an example of the process according to the first embodiment will be described with reference to FIG. 12. FIG. 12 is a sequence diagram illustrating an example of a schematic flow of the process according to the first embodiment. Also, the process is executed, for example,

when it is determined (for example, by the base station **100-1**) that the shared band (that is, a frequency band shared between the cellular communication and other wireless communication) is used in the cellular communication.

[0211] The base station **100-1** transmits an RTS frame using a shared band (**S301**).

[0212] The base station **100-1** and the terminal device **200-1** perform cellular communication using the above-mentioned shared band in a period after the transmission of the RTS frame (**S303**). That is, the base station **100-1** and the terminal device **200-1** transmit a signal of the cellular communication in the period.

[0213] Also, as described, the base station **100-1** may transmit another type of frame in place of the RTS frame.

3.5. First Modified Example

[0214] Hereinafter, the first modified example of the first embodiment will be described with reference to FIGS. **13** and **14**.

[0215] Summary

[0216] In the above-mentioned example of the first embodiment, only the base station **100-1** transmits a frame (that is, a frame including duration information for setting an NAV).

[0217] On the other hand, in the first modified example of the first embodiment, the base station **100-1** transmits the frame (that is, the frame including the duration information for setting the NAV), and the terminal device **200-1** transmits another frame including the duration information for setting the NAV according to the reception of the above-mentioned frame.

[0218] Thereby, for example, a hidden terminal problem can be solved.

[0219] (Base Station **100-1**: Communication Control Unit **151**)

[0220] (a) Frame Transmission Using Shared Band

[0221] As described above, the communication control unit **151** controls a wireless communication device for performing cellular communication so that the wireless communication device transmits a frame including duration information for setting the NAV using the above-mentioned shared band.

[0222] Wireless Communication Device

[0223] Even in the first modified example, the above-mentioned wireless communication device includes the base station **100-1**. That is, the communication control unit **151** controls the base station **100-1** so that the base station **100-1** transmits the above-mentioned frame using the above-mentioned shared band.

[0224] Frame

[0225] As described above, for example, the above-mentioned frame has a duration field and includes the above-mentioned duration information in the duration field.

[0226] Particularly, in the first modified example, the above-mentioned frame is a frame for causing another frame including the duration information for setting the NAV to be transmitted to a specific device for receiving the above-mentioned frame.

[0227] Specific Example of Frame and Other Frame

[0228] For example, the above-mentioned frame is an RTS frame and the above-mentioned other frame is a CTS frame. That is, the base station **100** transmits the RTS frame and the above-mentioned specific device transmits the CTS frame according to the reception of the RTS frame.

[0229] Also, the above-mentioned frame may not be the RTS frame. For example, the above-mentioned frame may be another type of frame similar to the RTS frame. Also, the above-mentioned other frame may not be the CTS frame. For example, the above-mentioned other frame may be another type of frame similar to the other frame.

[0230] Specific Device

[0231] The above-mentioned specific device is the terminal device **200-1**. That is, the above-mentioned frame is a frame for causing the above-mentioned other frame to be transmitted to the terminal device **200-1** for receiving the above-mentioned frame.

[0232] As a first example, the above-mentioned frame has a reception address field and includes a predetermined value in the reception address field. The terminal device **200-1** transmits the above-mentioned other frame using the above-mentioned shared band when the above-mentioned frame including the above-mentioned predetermined value in the reception address field is received using the above-mentioned shared band. Also, a predetermined value may be included in another field (for example, a transmission address field) in place of the reception address field, and the terminal device **200-1** may transmit the above-mentioned other frame using the above-mentioned shared band when the frame including the above-mentioned predetermined value is received using the above-mentioned shared band.

[0233] As a second example, the above-mentioned frame has a reception address field and may include an address of a specific terminal device **200-1** in the reception address field. The specific terminal device **200-1** may transmit the above-mentioned other frame using the above-mentioned shared band when a frame including the address of the above-mentioned specific terminal device **200-1** in the reception address field is received using the above-mentioned shared band.

[0234] The above-mentioned frame according to the first modified example has been described above. According to the transmission of the above-mentioned frame, for example, a hidden terminal problem can be solved. More specifically, for example, according to the frame (for example, the RTS frame), it is possible to cause the above-mentioned specific device to transmit the frame (for example, the CTS frame) for setting the NAV. Thus, a wireless LAN device capable of receiving the signal transmitted by the terminal device without receiving a signal transmitted by the base station **100-1** can set the NAV. As a result, interference between the cellular communication and the wireless LAN communication can be suppressed.

[0235] (b) Cellular Communication Using Shared Band

[0236] As described above, the communication control unit **151** controls the base station **100-1** so that the cellular communication is performed using the above-mentioned shared band in the period after the transmission of the above-mentioned frame.

[0237] Period

[0238] Start Time-Point of Period

[0239] For example, the above-mentioned period after the transmission of the above-mentioned frame is a period after the transmission of the above-mentioned other frame. Thereby, for example, it is possible to avoid interference between cellular communication and wireless LAN communication of a wireless LAN device for receiving a signal of the above-mentioned other frame without receiving a signal of the above-mentioned frame.

Specific Example

[0240] FIG. 13 is an explanatory diagram illustrating a period in which cellular communication is performed using a shared band in the first modified example of the first embodiment. Referring to FIG. 13, first, the base station 100-1 transmits an RTS frame. Then, the terminal device 200-1 transmits a CTS frame according to the reception of the RTS frame. At a point in time at which the SIFS has elapsed from an end time-point of the transmission (or the reception) of the above-mentioned CTS frame, the base station 100-1 starts the cellular communication with the terminal device 200-1 using the shared band. Also, the base station 100-1 terminates the cellular communication before the passage of a period of the NAV set according to the RTS frame (or the period of the NAV set according to the CTS frame).

[0241] (Terminal Device 200-1: Communication Control Unit 241)

[0242] In the first modified example, the communication control unit 241 controls the terminal device 200-1 so that the terminal device 200-1 transmits another frame including duration information for setting the NAV using the shared band according to the reception of the above-mentioned frame transmitted using the above-mentioned shared band by the base station 100-1.

[0243] Frame

[0244] The above-mentioned frame and the above-mentioned other frame have been described in relation to the communication control unit 151 of the base station 100-1. Consequently, redundant description will be omitted here.

[0245] Duration Information

[0246] As described above, the above-mentioned duration information included in the above-mentioned other frame is information for setting the NAV. For example, the above-mentioned duration information indicates the duration. Also, the duration is a period after the transmission of the above-mentioned frame and covers the period in which the cellular communication is performed using the above-mentioned shared band.

[0247] For example, the duration is determined on the basis of the duration information included in the above-mentioned frame (for example, by the communication control unit 241). As an example, a period which is a sum of a length of the above-mentioned other frame and a length of the SIFS shorter than the duration indicated by the duration information included in the above-mentioned frame is determined to be the duration indicated by the above-mentioned duration information included in the above-mentioned other frame.

[0248] According to the transmission of the above-mentioned other frame including such duration information, for example, it is possible to cause a wireless LAN device for receiving the above-mentioned other frame to set the NAV to cover the period in which the cellular communication is performed using the above-mentioned shared band. Consequently, the use of the above-mentioned frequency band by the wireless LAN device can be prevented while the cellular communication is performed using the above-mentioned shared band.

[0249] Timing of Transmission

[0250] The above-mentioned other frame, for example, starts to be transmitted at a point in time at which the SIFS has elapsed from an end time-point of the reception of the above-mentioned frame. For example, the communication

control unit 241 performs control so that the above-mentioned other frame starts to be transmitted as described above.

[0251] (Flow of Process)

[0252] FIG. 14 is a sequence diagram illustrating an example of a schematic flow of the process according to the first modified example of the first embodiment. Also, the process is executed, for example, when it is determined that a shared band (that is, a frequency band shared between the cellular communication and the other wireless communication) is used in the cellular communication (for example, by the base station 100-1).

[0253] The base station 100-1 transmits an RTS frame using a shared band (S311).

[0254] The terminal device 200-1 transmits a CTS frame using the shared band according to the reception of the above-mentioned RTS (S313).

[0255] The base station 100-1 and the terminal device 200-1 perform cellular communication using the above-mentioned shared band in a period after the transmission of the CTS frame (S315). That is, the base station 100-1 and the terminal device 200-1 transmit a signal of the cellular communication in the period.

[0256] Also, a group of terminal devices 200-1 for transmitting the CTS frame and a group of terminal devices 200-1 for performing cellular communication may be the same, may partially overlap, or may not overlap.

[0257] Also, as described above, the base station 100-1 may transmit another type of frame in place of the RTS frame. Also, the terminal device 200-1 may transmit another type of frame in place of the CTS frame.

3.6. Second Modified Example

[0258] Hereinafter, the second modified example of the first embodiment will be described with reference to FIGS. 15 and 16.

[0259] Summary

[0260] In the above-mentioned first embodiment, only the base station 100-1 transmits a frame including duration information for setting an NAV.

[0261] On the other hand, in the second modified example of the first embodiment, the base station 100-1 transmits a first frame including duration information for setting the NAV and instructs the terminal device 200-1 to transmit a second frame including duration information for setting the NAV. Also, the terminal device 200-1 transmits the above-mentioned second frame according to the instruction from the base station 100-1. Thereby, for example, a hidden terminal problem can be solved.

[0262] Thereby, for example, the hidden terminal problem can be solved. Also, for example, the terminal device 200-1 may not decrypt a frame transmitted by the base station 100-1, and a burden on the terminal device 200-1 can be reduced. Also, for example, the base station 100-1 can freely select the terminal device 200-1 for transmitting the above-mentioned other frame.

[0263] (Base Station 100-1: Communication Control Unit 151)

[0264] (a) Frame Transmission Using Shared Band

[0265] As described above, the communication control unit 151 controls a wireless communication device for performing cellular communication so that the above-mentioned wireless communication device transmits the frame

including the duration information for setting the NAV using the above-mentioned shared band.

[0266] Wireless Communication Device

[0267] Base Station **100-1**

[0268] Even in the second modified example, the above-mentioned wireless communication device includes the base station **100-1**. That is, the communication control unit **151** controls the base station **100-1** so that the base station **100-1** transmits the frame including the duration information for setting the NAV using the above-mentioned shared band. Also, in the second modified example, the above-mentioned frame transmitted by the base station **100-1** is referred to as a “first frame.”

[0269] Terminal Device **200-1**

[0270] Particularly, in the second modified example, the above-mentioned wireless communication device includes the terminal device **200-1**. That is, the communication control unit **151** controls the terminal device **200-1** so that the terminal device **200-1** transmits a frame including duration information for setting the NAV using the above-mentioned shared band. Also, in the second modified example, the above-mentioned frame transmitted by the terminal device **200-1** is referred to as a “second frame.”

[0271] Instruction for Terminal Device **200-1**

[0272] Specifically, for example, the communication control unit **151** instructs the terminal device **200-1** to transmit the second frame using the above-mentioned shared band. For example, the communication control unit **151** uses another frequency band for the cellular system **1** to instruct the terminal device **200-1** to transmit the second frame using the above-mentioned shared band.

[0273] As an example, through control by the communication control unit **151**, the base station **100-1** transmits a frame transmission instruction message to the terminal device **200-1** using the above-mentioned other frequency band. Thereby, the terminal device **200-1** transmits the above-mentioned second frame using the above-mentioned shared band.

[0274] According to the transmission of the above-mentioned second frame by the terminal device **200-1**, for example, the hidden terminal problem can be solved.

[0275] This is identical to the description of the first modified example.

[0276] Also, according to an instruction for the terminal device **200-1**, for example, it is unnecessary for the terminal device **200-1** to decrypt the first frame transmitted by the base station **100-1**, and a burden of the terminal device **200-1** can be reduced. Also, for example, the base station **100-1** can freely select the terminal device **200-1** which transmits the above-mentioned second frame.

[0277] Provision of Timing Information

[0278] For example, the communication control unit **151** provides the terminal device **200-1** with information which specifies a timing at which the above-mentioned second frame is transmitted (hereinafter referred to as “timing information”).

[0279] Specifically, for example, through control by the communication control unit **151**, the base station **100-1** transmits the frame transmission instruction message including the above-mentioned timing information to the terminal device **200-1** using the above-mentioned other frequency band.

[0280] For example, the above-mentioned timing is any timing after the base station **100-1** transmits the above-mentioned first frame.

[0281] According to the provision of the above-mentioned timing information, for example, the base station **100-1** can control the timing of transmission of the second frame by the terminal device **200-1**. Also, according to the provision of the above-mentioned timing information, for example, it is possible to cause a plurality of terminal devices **200-1** to simultaneously transmit second frames.

[0282] Provision of Duration Information

[0283] Also, for example, the communication control unit **151** provides the terminal device **200-1** with the above-mentioned duration information included in the above-mentioned second frame. Alternatively, the communication control unit **151** provides the terminal device **200-1** with information which specifies the duration information.

[0284] Specifically, for example, through control by the communication control unit **151**, the base station **100-1** transmits a frame transmission instruction message including the above-mentioned duration information included in the above-mentioned second frame (or information which specifies the above-mentioned duration information) to the terminal device **200-1** using the above-mentioned other frequency band.

[0285] For example, the duration indicated by the above-mentioned duration information is a duration from a point in time at which the SIFS has elapsed from an end time-point of the transmission of the above-mentioned second frame to a point in time at which the duration indicated by the duration information included in the above-mentioned first frame ends.

[0286] According to the provision of the above-mentioned duration information, for example, the base station **100-1** can control a period in which a wireless LAN device for receiving the second frame transmitted by the terminal device **200-1** avoids transmitting a signal.

[0287] Frame, Duration Information, Timing of Transmission

[0288] The first frame transmitted by the base station **100-1**, the duration information included in the first frame, and the transmission timing of the frame are the same as described in the example of the first embodiment. Consequently, redundant description will be omitted here.

[0289] Also, the second frame transmitted by the terminal device **200-1**, the duration information included in the second frame, and the transmission timing of the frame will be described in relation to the communication control unit **241** of the terminal device **200-2**.

[0290] (b) Cellular Communication Using Shared Band

[0291] As described above, the communication control unit **151** controls the base station **100-1** so that the cellular communication is performed using the above-mentioned shared band in the period after the transmission of the above-mentioned frame.

[0292] Period

[0293] Start Time-Point of Period

[0294] For example, the above-mentioned period after the transmission of the above-mentioned frame is a period after the transmission of the above-mentioned second frame. Thereby, for example, it is possible to avoid interference between cellular communication and wireless LAN communication of a wireless LAN device for receiving a signal

of the above-mentioned second frame without receiving a signal of the above-mentioned first frame.

Specific Example

[0295] FIG. 15 is an explanatory diagram illustrating a period in which cellular communication is performed using a shared band in the second modified example of the first embodiment. Referring to FIG. 15, first, the base station 100-1 transmits an RTS frame. Also, the terminal device 200-1 transmits a CTS frame at a timing indicated by timing information provided by the base station 100-1. At a point in time at which the SIFS has elapsed from an end time-point of the transmission (or the reception) of the CTS frame, the base station 100-1 starts the cellular communication with the terminal device 200-1 using the shared band. Also, the base station 100-1 terminates the cellular communication before the passage of a period of an NAV set according to the RTS frame (or the period of the NAV set according to the CTS frame).

[0296] (Terminal Device 200-1: Communication Control Unit 241)

[0297] In the second modified example, the communication control unit 241 controls the terminal device 200-1 so that the terminal device 200-1 transmits the second frame including the duration information for setting the NAV using the above-mentioned shared band according to an instruction from the base station 100-1.

[0298] Frame

[0299] For example, the above-mentioned second frame has a duration field and includes the duration information in the duration field.

[0300] As an example, the above-mentioned second frame is a CTS frame. As another example, the above-mentioned second frame may be an RTS frame. As still another example, the above-mentioned second frame may be another type of frame similar to the CTS frame and the RTS frame.

[0301] Duration Information

[0302] As described above, the above-mentioned duration information included in the above-mentioned second frame is information for setting the NAV. For example, the above-mentioned duration information indicates a duration. Also, the duration is a period after the transmission of the above-mentioned second frame and covers the period in which the cellular communication is performed using the above-mentioned shared band. As described above, the above-mentioned duration information is provided, for example, by the base station 100-1.

[0303] According to the transmission of the second frame including such duration information, for example, it is possible to cause the wireless LAN device for receiving the second frame to set the NAV to cover the period in which the cellular communication is performed using the above-mentioned shared band.

[0304] Consequently, the use of the above-mentioned shared band by the wireless LAN device can be prevented while the cellular communication is performed using the above-mentioned shared band.

[0305] Also, the duration indicated by the above-mentioned duration information included in the above-mentioned second frame may cover a part of the above-mentioned period in which the cellular communication is performed using the above-mentioned shared band. An additional frame including the duration information for setting the NAV may be transmitted through control by the

communication control unit 241 at any timing after the transmission of the above-mentioned second frame. The description of this regard is the same as the corresponding description of the communication control unit 151 according to the first embodiment. Consequently, redundant description will be omitted here.

[0306] Timing of Transmission

[0307] The above-mentioned second frame is transmitted, for example, at the timing specified from the above-mentioned timing information provided by the base station 100-1.

[0308] (Flow of Process)

[0309] FIG. 16 is a sequence diagram illustrating an example of a schematic flow of the process according to the second modified example of the first embodiment. Also, the process is executed, for example, when it is determined (for example, by the base station 100-1) that the shared band (that is, a frequency band shared between the cellular communication and other wireless communication) is used in the cellular communication.

[0310] The base station 100-1 transmits an RTS frame using a shared band (S321).

[0311] Also, the base station 100-1 transmits a frame transmission instruction message including timing information and duration information to the terminal device 200-1 using another frequency band for the cellular system 1 (S323).

[0312] The terminal device 200-1 transmits a CTS frame including the above-mentioned duration information at a timing specified from the above-mentioned timing information (S325).

[0313] The base station 100-1 and the terminal device 200-1 perform cellular communication using the above-mentioned shared band in a period after the transmission of the CTS frame (S327). That is, the base station 100-1 and the terminal device 200-1 transmit a signal of the cellular communication in the period.

[0314] Also, a group of terminal devices 200-1 for transmitting the CTS frame and a group of terminal devices 200-1 for performing cellular communication may be the same, may partially overlap, or may not overlap.

[0315] Also, as described above, the base station 100-1 may transmit another type of frame in place of the RTS frame. Also, the terminal device 200-1 may transmit another type of frame in place of the CTS frame.

3.7. Third Modified Example

[0316] Hereinafter, the third modified example of the first embodiment will be described with reference to FIGS. 17 and 18.

[0317] Summary

[0318] In the above-mentioned example of the first embodiment, only the base station 100-1 transmits a frame including duration information for setting an NAV.

[0319] On the other hand, in the third modified example of the first embodiment, the base station 100-1 instructs the terminal device 200-1 to transmit a frame including duration information for setting the NAV. Also, the terminal device 200-1 transmits the above-mentioned frame according to the instruction from the base station 100-1.

[0320] (Base Station **100-1**: Communication Control Unit **151**)

[0321] (a) Frame Transmission Using Shared Band

[0322] As described above, the communication control unit **151** controls a wireless communication device for performing cellular communication so that the above-mentioned wireless communication device transmits the frame including the duration information for setting the NAV using the above-mentioned shared band.

[0323] Wireless Communication Device

[0324] Particularly, in the third modified example, the above-mentioned wireless communication device includes the terminal device **200-1**. That is, the communication control unit **151** controls the terminal device **200-1** so that the terminal device **200-1** transmits the frame including the duration information for setting the NAV using the above-mentioned shared band.

[0325] Also, in the third modified example, the above-mentioned wireless communication device does not include the base station **100-1**.

[0326] Instruction for Terminal Device **200-1**

[0327] Specifically, for example, the communication control unit **151** instructs the terminal device **200-1** to transmit the above-mentioned frame using the above-mentioned shared band. For example, the communication control unit **151** uses another frequency band for the cellular system **1** to instruct the terminal device **200-1** to transmit the above-mentioned frame using the above-mentioned shared band.

[0328] As an example, through control by the communication control unit **151**, the base station **100-1** transmits a frame transmission instruction message to the terminal device **200-1** using the above-mentioned other frequency band. Thereby, the terminal device **200-1** transmits the above-mentioned frame using the above-mentioned shared band.

[0329] Provision of Timing Information

[0330] For example, the communication control unit **151** provides the terminal device **200-1** with information which specifies the timing at which the above-mentioned frame is transmitted (hereinafter referred to as “timing information”).

[0331] Specifically, for example, through control by the communication control unit **151**, the base station **100-1** transmits the frame transmission instruction message including the above-mentioned timing information to the terminal device **200-1** using the above-mentioned other frequency band.

[0332] According to the provision of the above-mentioned timing information, for example, the base station **100-1** can control the timing of the transmission of the frame by the terminal device **200-1**. Also, according to the provision of the above-mentioned timing information, for example, it is possible to cause a plurality of terminal devices **200-1** to simultaneously transmit frames.

[0333] Provision of Duration Information

[0334] Also, for example, the communication control unit **151** provides the terminal device **200-1** with the above-mentioned duration information included in the above-mentioned frame. Alternatively, the communication control unit **151** provides the terminal device **200-1** with information which specifies the duration information.

[0335] Specifically, for example, through control by the communication control unit **151**, the base station **100-1** transmits a frame transmission instruction message including the above-mentioned duration information included in

the above-mentioned frame (or information which specifies the above-mentioned duration information) to the terminal device **200-1** using the above-mentioned other frequency band.

[0336] According to the provision of the above-mentioned duration information, for example, the base station **100-1** can control a period in which a wireless LAN device for receiving the above-mentioned frame avoids transmitting of a signal.

[0337] Frame, Duration Information, Timing of Transmission

[0338] The frame transmitted by terminal device **200-1**, the duration information included in the frame, and the transmission timing of the frame will be described in relation to the communication control unit **241** of the terminal device **200-2**.

[0339] (b) Cellular Communication Using Shared Band

[0340] As described above, the communication control unit **151** controls the base station **100-1** so that the cellular communication is performed using the above-mentioned shared band in the period after the transmission of the above-mentioned frame.

[0341] Period

[0342] Start Time-Point of Period

[0343] For example, the above-mentioned period after the transmission of the above-mentioned frame is a period after the transmission of the above-mentioned frame. Thereby, for example, it is possible to avoid interference between cellular communication and wireless LAN communication of a wireless LAN device for receiving a signal of the above-mentioned frame.

Specific Example

[0344] FIG. 17 is an explanatory diagram illustrating a period in which cellular communication is performed using a shared band in the third modified example of the first embodiment. Referring to FIG. 17, the terminal device **200-1** transmits a CTS frame at a timing indicated by timing information provided by the base station **100-1**. At a point in time at which the SIFS has elapsed from an end time-point of the transmission (or the reception) of the CTS frame, the base station **100-1** starts the cellular communication with the terminal device **200-1** using the shared band. Also, the base station **100-1** terminates the cellular communication before the passage of a period of an NAV set according to the CTS frame.

[0345] (Terminal Device **200-1**: Communication Control Unit **241**)

[0346] In the third modified example, the communication control unit **241** controls the terminal device **200-1** so that the terminal device **200-1** transmits the frame including the duration information for setting the NAV using the above-mentioned shared band according to an instruction from the base station **100-1**.

[0347] Frame

[0348] For example, the above-mentioned frame has a duration field and includes the duration information in the duration field.

[0349] As an example, the above-mentioned frame is a CTS frame. As another example, the above-mentioned frame may be an RTS frame. As still another example, the above-mentioned frame may be another type of frame similar to the CTS frame and the RTS frame.

[0350] Duration Information

[0351] As described above, the above-mentioned duration information included in the above-mentioned frame is information for setting the NAV. For example, the above-mentioned duration information indicates a duration. Also, the duration is a period after the transmission of the above-mentioned frame and covers the period in which the cellular communication is performed using the above-mentioned shared band. As described above, the duration information is provided, for example, by the base station **100-1**.

[0352] According to the transmission of the above-mentioned frame including such duration information, for example, it is possible to cause a wireless LAN device for receiving the above-mentioned frame to set the NAV to cover the period in which the cellular communication is performed using the above-mentioned shared band. Consequently, the use of the above-mentioned frequency band by the wireless LAN device can be prevented while the cellular communication is performed using the above-mentioned shared band.

[0353] Also, the duration indicated by the above-mentioned duration information included in the above-mentioned frame may cover a part of the above-mentioned period in which the cellular communication is performed using the above-mentioned shared band. An additional frame including the duration information for setting the NAV may be transmitted through control by the communication control unit **241** at any timing after the transmission of the above-mentioned frame. The description of this regard is the same as the corresponding description of the communication control unit **151** according to the first embodiment. Consequently, redundant description will be omitted here.

[0354] Timing of Transmission

[0355] The above-mentioned frame is transmitted, for example, at the timing specified from the above-mentioned timing information provided by the base station **100-1**.

[0356] (Flow of Process)

[0357] FIG. **18** is a sequence diagram illustrating an example of a schematic flow of the process according to the third modified example of the first embodiment. Also, the process is executed, for example, when it is determined (for example, by the base station **100-1**) that the shared band (that is, a frequency band shared between the cellular communication and other wireless communication) is used in the cellular communication.

[0358] Also, the base station **100-1** transmits a frame transmission instruction message including timing information and duration information to the terminal device **200-1** (**S331**).

[0359] The terminal device **200-1** transmits a CTS frame including the above-mentioned duration information at a timing specified from the above-mentioned timing information (**S333**).

[0360] The base station **100-1** and the terminal device **200-1** perform cellular communication using the above-mentioned shared band in a period after the transmission of the CTS frame (**S335**). That is, the base station **100-1** and the terminal device **200-1** transmit a signal of the cellular communication in the period.

[0361] Also, a group of terminal devices **200-1** for transmitting the CTS frame and a group of terminal devices **200-1** for performing cellular communication may be the same, may partially overlap, or may not overlap.

[0362] Also, as described above, the terminal device **200-1** may transmit another type of frame in place of the CTS frame.

4. SECOND EMBODIMENT

[0363] Next, the second embodiment of the present disclosure will be described with reference to FIGS. **20** and **21**.

4.1. Summary

[0364] First, the summary of the second embodiment will be described.

[0365] According to the first embodiment, through control by the base station **100-1**, the wireless communication device for performing the cellular communication transmits the frame including duration information for setting the NAV using the shared band (that is, a frequency band shared between the cellular communication and wireless LAN communication). Through control by the base station **100-1**, the cellular communication is performed using the above-mentioned frequency band in the period after the transmission of the above-mentioned frame. Also, the above-mentioned wireless communication device is the base station **100-1** or the terminal device **200-1**.

[0366] On the other hand, according to the second embodiment, through control by a terminal device **200-2**, a wireless communication device for performing cellular communication transmits a frame including duration information for setting an NAV using a shared band. Through control by the terminal device **200-2**, the cellular communication is performed using the above-mentioned frequency band in a period after the transmission of the above-mentioned frame. Also, the above-mentioned wireless communication device is the terminal device **200-2** or another terminal device **200-2**.

[0367] Thereby, for example, while the shared band (that is, the frequency band shared between the cellular communication and the wireless LAN communication) is used in wireless communication between the terminal devices in the cellular system, the above-mentioned shared band can be prevented from being used in wireless LAN communication.

4.2. Configuration of Terminal Device

[0368] Next, an example of the configuration of a terminal device **200-2** according to the second embodiment will be described with reference to FIG. **19**. FIG. **19** is a block diagram illustrating the example of the configuration of the terminal device **200-2** according to the second embodiment. Referring to FIG. **19**, the terminal device **200-2** includes an antenna unit **210**, a wireless communication unit **220**, a storage unit **230**, and a processing unit **250**.

[0369] Here, the description of the antenna unit **210**, the wireless communication unit **220**, and the storage unit **230** is not different between the first embodiment and the second embodiment except for a difference of reference signs. Consequently, here, only the processing unit **250** will be described and redundant description will be omitted.

[0370] (Processing Unit **250**)

[0371] The processing unit **250** provides various functions of the terminal device **200-2**. The processing unit **250** includes a communication control unit **251**. Also, the processing unit **250** can further include another component in addition to the communication control unit **251**.

[0372] (Communication Control Unit 251)

[0373] For example, the terminal device 200-1 operates in a first mode or a second mode, and the communication control unit 251 performs control according to the first mode or the second mode.

[0374] (a) First Mode

[0375] Frame Transmission Using Shared Band

[0376] In the first mode, the communication control unit 251 controls a wireless communication device for performing cellular communication so that the above-mentioned wireless communication device transmits a frame including duration information for setting an NAV using a frequency band shared between cellular communication and wireless LAN communication (that is, a shared band). For example, the above-mentioned wireless communication device includes the terminal device 200-2 (which operates in the first mode) or another terminal device 200-2 (which operates in the second mode).

[0377] The description of the communication control unit 251 in this regard is the same as the corresponding description for the communication control unit 151 of the base station 100-1 according to the above-mentioned first embodiment, except for differences related to entities (the base station 100-1 and the terminal device 200-2) which perform control and a control target (that is, the wireless communication device). Consequently, redundant description will be omitted here.

[0378] Also, additionally, in the first embodiment, through control by the communication control unit 151 of the base station 100-1, the base station 100-1 or the terminal apparatus 200-1 transmits the above-mentioned frame using the above-mentioned shared band. On the other hand, in the second embodiment, the terminal device 200-1 or the other terminal device 200-1 transmits the above-mentioned frame using the above-mentioned shared band through control by the communication control unit 251 of the terminal device 200-2. However, the description of the technique of the control, the frame to be transmitted, the duration information, and the timing of the transmission are the same, for example, between the first and second embodiments.

[0379] Cellular Communication Using Shared Band

[0380] In the first mode, the communication control unit 251 controls the terminal device 200-2 so that the cellular communication is performed using the above-mentioned shared band in the period after the transmission of the above-mentioned frame.

[0381] For example, the communication control unit 251 controls the terminal device 200-2 so that the wireless communication between terminal devices in the cellular system 1 is performed using the above-mentioned shared band in the above-mentioned period.

[0382] The description of the communication control unit 251 in this regard is the same as the corresponding description for the communication control unit 151 of the base station 100-1 according to the above-mentioned first embodiment, except for differences related to the entities (the base station 100-1 and the terminal device 200-2) which perform control and a type of cellular communication. Consequently, redundant description will be omitted here.

[0383] Also, additionally, in the first embodiment, through control by the communication control unit 151 of the base station 100-1, cellular communication between the base station 100-1 and the terminal apparatus 200-1 is performed using the above-mentioned shared band. On the other hand,

in the second embodiment, the cellular communication between the terminal device 200-2 and the other terminal device 200-2 is performed using the above-mentioned shared band through control by the communication control unit 251 of the terminal device 200-2. However, the description of the period and the duplex operation are the same, for example, between the first and second embodiments.

[0384] (b) Second Mode

[0385] Frame Transmission Using Shared Band

[0386] In the second mode, the communication control unit 251 controls the terminal device 200-1 so that the terminal device 200-2 transmits a frame including duration information for setting an NAV using the above-mentioned shared band.

[0387] For example, the communication control unit 251 controls the terminal device 200-1 so that the terminal device 200-2 transmits a frame including duration information for setting the NAV using the above-mentioned shared band according to the reception of the frame (that is, the frame including the duration information for setting the NAV) transmitted using the above-mentioned shared band by the terminal device 200-2 (which operates in the first mode).

[0388] Also, for example, the communication control unit 251 controls the terminal device 200-2 so that the terminal device 200-2 transmits the frame including the duration information for setting the NAV using the above-mentioned shared band according to an instruction from the terminal device 200-2 (which operates in the first mode).

[0389] The description of the communication control unit 251 in this regard is the same as the corresponding description for the communication control unit 241 of the terminal device 200-1 according to the above-mentioned first embodiment, except for differences related to a partner device (the base station 100-1 and the terminal device 200-2 (which operates in the first mode)). Consequently, redundant description will be omitted here.

[0390] Also, additionally, in the first embodiment, through control by the communication control unit 241 of the terminal device 200-1, the terminal device 200-1 transmits a frame including duration information for setting the NAV using the above-mentioned shared band according to a frame transmitted by the base station 100-1 or an instruction from the base station 100-1. On the other hand, in the second embodiment, through control by the communication control unit 251 of the terminal device 200-2, the terminal device 200-2 (which operates in the second mode) transmits a frame including duration information for setting the NAV using the above-mentioned shared band according to a frame transmitted by another terminal device 200-2 (which operates in the first mode) or an instruction from the other terminal device 200-2. However, the description of the technique of the control, the frame to be transmitted, the duration information, and the timing of the transmission are the same, for example, between the first and second embodiments.

[0391] Also, in the first embodiment, for example, frame transmission and cellular communication are performed between the base station 100-1 and the terminal device 200-1, for example, in FIGS. 7, 8, 9, 10, 13, 15, 17, and 20. On the other hand, in the second embodiment, for example, the frame transmission/reception and the cellular communication (wireless communication between the terminal devices in the cellular system) between the terminal device

200-2 (which operates in the first mode) and the terminal device **200-2** (which operates in the second mode) are similarly performed.

4.3. Flow of Process

[0392] The example of the process according to the second embodiment is the same as the examples of the process described with reference to FIGS. **12**, **14**, **16**, and **18**, except for differences related to the entities. Consequently, redundant description will be omitted here.

[0393] Also, additionally, the process according to the first embodiment is a process by the base station **100-1** and the terminal device **200-1**, and the process according to the second embodiment is a process by the terminal device **200-2** (which operates in the first mode) and the terminal device **200-2** (which operates in the second mode).

5. THIRD EMBODIMENT

[0394] Next, the third embodiment of the present disclosure will be described with reference to FIGS. **20** to **28**.

5.1. Summary

[0395] First, the summary of the third embodiment will be described.

[0396] Problem According to Third Embodiment

[0397] For example, a device for performing wireless LAN communication can transmit a signal (for example, a signal of an RTS frame) using a frequency band (channel) when a period in which no signal is transmitted using the frequency band reaches a sum of a DIFS and a backoff time. For example, the DIFS is shorter than a symbol of LTE (an OFDM symbol or an SC-FDMA symbol).

[0398] For example, a frequency band (for example, a channel of a wireless LAN) is shared between the cellular communication and the wireless LAN communication. In this case, for example, it may be impossible to transmit any signal of the cellular system using the above-mentioned frequency band in any symbol even while the above-mentioned frequency band is used in the cellular communication. Thus, the device for performing the wireless LAN communication is likely to transmit a signal (for example, a signal of an RTS frame) using the above-mentioned frequency band even while the above-mentioned frequency band is used in cellular communication. Thus, the interference between the cellular communication and the wireless LAN communication occurs in the above-mentioned frequency band and the communication quality of the above-mentioned cellular communication and/or the above-mentioned other wireless communication is likely to deteriorate.

[0399] Therefore, it is desirable to provide a mechanism for enabling the frequency band shared between the cellular communication and the other wireless communication to be more appropriately used in the cellular system. More specifically, it is desirable to provide a mechanism capable of preventing the above-mentioned frequency band from being used in the above-mentioned other wireless communication while the frequency band shared between the cellular communication and the other wireless communication (for example, wireless LAN communication) is used in the cellular communication.

[0400] Characteristics of Third Embodiment

[0401] According to the third embodiment, at any time, a wireless communication device for performing cellular

communication is controlled so that the above-mentioned wireless communication device transmits a signal using a frequency band shared between the cellular communication and other wireless communication (that is, a shared band). Thereby, for example, it is possible to prevent the above-mentioned frequency band from being used in the above-mentioned other wireless communication while the frequency band shared between the cellular communication and the other wireless communication (for example, wireless LAN communication) is used in the cellular communication.

5.2. Configuration of Base Station

[0402] Next, an example of the configuration of a base station **100-3** according to the third embodiment will be described with reference to FIGS. **20** to **25**. FIG. **20** is a block diagram illustrating an example of the configuration of the base station **100-3** according to the third embodiment. Referring to FIG. **20**, the base station **100-3** is equipped with an antenna unit **110**, a wireless communication unit **120**, a network communication unit **130**, a storage unit **140**, and a processing unit **170**.

[0403] Here, the description of the antenna unit **110**, the wireless communication unit **120**, the network communication unit **130**, and the storage unit **140** is not different between the first embodiment and the third embodiment, except for a difference of reference signs. Consequently, here, only the processing unit **170** will be described and redundant description will be omitted.

[0404] (Processing unit **170**)

[0405] The processing unit **170** provides various functions of the base station **100-3**. The processing unit **170** includes a communication control unit **171**. Also, the processing unit **170** can further include another component in addition to the communication control unit **171**.

[0406] (Communication Control Unit **171**)

[0407] The communication control unit **171** controls a wireless communication device for performing the cellular communication so that the above-mentioned wireless communication device transmits a signal using the above-mentioned shared at any time. The above-mentioned shared band is a frequency band shared between wireless communication (that is, a cellular communication) of the cellular system **1** and other wireless communication.

[0408] (a) Other Wireless Communication

[0409] For example, the above-mentioned wireless communication is wireless communication (that is, wireless LAN communication) conforming to a wireless LAN standard. In this case, the above-mentioned shared band is shared between the cellular communication and the wireless LAN communication. The above-mentioned shared band is, for example, a channel of a wireless LAN.

[0410] (b) Unit of Time

[0411] The communication control unit **171** controls the above-mentioned wireless communication device so that the above-mentioned wireless communication device transmits a signal using the above-mentioned shared band in each symbol. The above-mentioned symbol is, for example, an OFDM symbol or an SC-FDMA symbol.

[0412] Thereby, for example, it is possible to eliminate a non-signal time.

[0413] (c) Wireless Communication Device

[0414] The above-mentioned wireless communication device is at least one of the base station 100-3 and the terminal device 200-3.

[0415] Case of FDD

[0416] Downlink Band

[0417] As a first example, the FDD is adopted in the cellular system 1 (that is, the duplex operation of the cellular system 1 is the FDD) and the above-mentioned shared band is used as the downlink band in the cellular system 1. In this case, the above-mentioned wireless communication device is the base station 100-3. That is, the communication control unit 171 controls the base station 100-3 so that the base station 100-3 transmits a signal using a shared band (downlink band) at any time.

[0418] Specifically, for example, the communication control unit 171 maps a signal to one or more resource elements within the above-mentioned shared band in each symbol. Thereby, the base station 100-3 transmits the signal using the above-mentioned shared band in each symbol.

[0419] Uplink Band

[0420] As a second example, the FDD is adopted in the cellular system 1 (that is, the duplex operation of the cellular system 1 is the FDD) and the above-mentioned shared band is used as the uplink band in the cellular system 1. In this case, the above-mentioned wireless communication device is a terminal device 200-3. That is, the communication control unit 171 controls the terminal device 200-3 so that the base station 100-3 transmits a signal using the above-mentioned shared band (uplink band) at any time.

[0421] Specifically, for example, the communication control unit 171 instructs the terminal device 200-3 to transmit a signal using the above-mentioned shared band at any time for the uplink.

[0422] Thereby, for example, the terminal device 200-3 can transmit a signal using the above-mentioned shared band at any time (in each symbol). Also, for example, this instruction can be performed according to RRC signaling or system information.

[0423] Case of TDD

[0424] As a third example, the TDD is adopted in the cellular system 1 (that is, the duplex operation of the cellular system 1 is the TDD) and the above-mentioned shared band is used as the downlink and uplink bands in the cellular system 1. In this case, the above-mentioned wireless communication device is the base station 100-3 and the terminal device 200-3.

[0425] For example, the communication control unit 171 controls the base station 100-3 so that the base station 100-3 transmits a signal using the above-mentioned shared band at any downlink time. Specifically, for example, the communication control unit 171 maps a signal to one or more resource elements within the above-mentioned shared band in each symbol for a downlink sub-frame. Thereby, the base station 100-3 transmits a signal using the above-mentioned shared band in each symbol within the downlink sub-frame.

[0426] Also, for example, the communication control unit 171 controls the terminal device 200-3 so that the terminal device 200-3 transmits a signal using the above-mentioned shared band at any uplink time. Specifically, for example, the communication control unit 171 instructs the terminal device 200-3 to transmit a signal using the above-mentioned shared band at any time for the uplink. Thereby, for example, the terminal device 200-3 can transmit a signal using the

above-mentioned shared band at any uplink time (in each symbol within the uplink sub-frame). Also, for example, this instruction can be performed according to RRC signaling or system information.

[0427] (d) Transmission Power

[0428] For example, the communication control unit 171 controls the above-mentioned wireless communication device so that transmission power of a signal to be transmitted using the above-mentioned shared band is greater than or equal to predetermined transmission power at any time.

[0429] For example, the above-mentioned wireless communication device is a base station 100-3 and the communication control unit 171 controls the base station 100-3 so that the transmission power of the signal to be transmitted using the above-mentioned shared band is greater than or equal to the predetermined transmission power at any time for the downlink. Specifically, for example, the communication control unit 171 allocates power greater than or equal to the above-mentioned predetermined transmission power to the signal to be transmitted using the above-mentioned shared band in each symbol.

[0430] Also, for example, the above-mentioned wireless communication system is the terminal device 200-3 and the communication control unit 171 controls the terminal device 200-3 so that the transmission power of the signal to be transmitted using the above-mentioned shared band is greater than or equal to the predetermined transmission power at any time for the uplink. Specifically, for example, the communication control unit 171 indicates the transmission power of a signal to be transmitted using the above-mentioned shared band to the terminal device 200-3.

[0431] Thereby, for example, in a device for performing other wireless communication (for example, wireless LAN communication), reception power of the above-mentioned signal can reach desired power. As a result, the device can more reliably avoid the transmission of a signal using the above-mentioned shared band.

[0432] (e) Technique of Transmission of Signal

[0433] Transmission of Dummy Signal

[0434] For example, the communication control unit 171 controls the base station 100-3 so that the base station 100-3 transmits a dummy signal using the above-mentioned shared band in at least a symbol in which neither a data signal nor a control signal of the cellular system 1 is transmitted using the above-mentioned shared band. Thereby, for example, it is possible to reliably transmit a signal in each symbol of downlink.

[0435] Also, the above-mentioned dummy signal is, for example, any signal other than signals (a control signal and a data signal) of the cellular system. The above-mentioned dummy signal is a busy tone for a device for performing wireless LAN communication.

[0436] Transmission of Dummy Signal in Some Radio Resources

[0437] For example, the communication control unit 171 controls the base station 100-3 so that the base station 100-3 transmits the above-mentioned dummy signal in some radio resources among radio resources arranged in a frequency direction across the above-mentioned shared band in at least the above-mentioned symbol.

[0438] Specifically, for example, the communication control unit 171 maps a dummy signal to one or more resource

elements (REs) within the above-mentioned shared band in at least a symbol in which a data signal and a control signal are not transmitted.

[0439] Transmission in Some Resource Blocks (RBs)

[0440] For example, some radio resources mentioned above are some RBs among RBs arranged in a frequency direction across the above-mentioned shared band. That is, the base station **100-3** transmits a dummy signal in some RBs among the RBs arranged in the frequency direction across the above-mentioned shared band. Hereinafter, in this regard, a specific example will be described with reference to FIGS. **21** and **22**.

[0441] FIG. **21** is an explanatory diagram illustrating an example of some RBs in which a dummy signal is transmitted. Referring to FIG. **21**, a shared band **71** and RBs arranged across a plurality of slots are illustrated. In this example, a dummy signal is transmitted in one specific RB among the RBs arranged in the frequency direction across the shared band **71** within each slot. Also, no dummy signal is transmitted in the other RBs.

[0442] FIG. **22** is an explanatory diagram illustrating a first example of an RE in which a dummy signal is transmitted. Referring to FIG. **22**, one of some RBs in which the dummy signal (for example, illustrated in FIG. **21**) is transmitted is illustrated. In this example, the dummy signal is transmitted in all REs other than a cell-specific reference signal (CRS) RE among REs included in the RB.

[0443] Thereby, for example, it is possible to allocate an RB in which no dummy signal is transmitted. Consequently, backward compatibility can be more easily secured.

[0444] Also, the dummy signal is transmitted in only one RB in the example of FIG. **21**, but, of course, the dummy signal may be transmitted in two or more RBs. Also, an RB band in which the dummy signal is transmitted is common between slots in the example of FIG. **21**, but, of course, the RB band in which the dummy signal is transmitted may be different between slots.

[0445] Also, the dummy signal is transmitted in all REs except for a CRS RE in the RB in the example of FIG. **22**, but, of course, the dummy signal may be transmitted in some REs in the RB. As an example, no dummy signal may be transmitted in one or more sub-carriers among 12 sub-carriers of the RB. As another example, no dummy signal may be transmitted in one or more symbols in which another signal is transmitted. As a specific example, no dummy signal may be transmitted in one or more symbols (that is, first to third OFDM symbols in a first slot of a sub-frame) in which signals of control channels such as a PDCCH and a PCFICH are transmitted. Also, as still another specific example, no dummy signal may be transmitted in one or more symbols in which a data signal is transmitted.

[0446] Transmission in Each RB

[0447] Also, some radio resources mentioned above may be some REs included in each RB arranged in the frequency direction across the above-mentioned shared band. That is, the base station **100-3** may transmit a dummy signal in some REs included in each RB arranged in the frequency direction across the above-mentioned shared band. Hereinafter, in this regard, a specific example will be described with reference to FIG. **23**.

[0448] FIG. **23** is an explanatory diagram illustrating a second example of an RE in which a dummy signal is transmitted. Referring to FIG. **23**, an RB when a dummy signal is transmitted in each RB is illustrated. In this

example, the dummy signal is transmitted in one or two specific REs among 12 REs arranged in the frequency direction across an RB within each symbol. Also, no dummy signal is transmitted in other REs.

[0449] Also, a dummy signal is transmitted in only REs of two sub-carriers in the example of FIG. **23**, but, of course, the dummy signal may be transmitted in an RE of one sub-carrier or may be transmitted in REs of three or more sub-carriers. Also, a sub-carrier of an RE in which the dummy signal is transmitted is common between symbols in the example of FIG. **23**, but, of course, the sub-carrier of the RE in which the dummy signal is transmitted may be different between symbols. Also, no dummy signal may be transmitted in one or more symbols in which another signal is transmitted among seven symbols of an RB. As a specific example, no dummy signal may be transmitted in one or more symbols (that is, first to third OFDM symbols of a first slot of a sub-frame) in which signals of control channels such as the PDCCH and the PCFICH are transmitted. As another specific example, no dummy signal may be transmitted in one or more symbols in which the data signal is transmitted.

[0450] (f) Transmission of Signal by Plurality of Terminal Devices

[0451] Instruction for Plurality of Terminal Devices

[0452] For example, the communication control unit **171** instructs each of the plurality of terminal devices **200-3** to transmit a signal using the above-mentioned shared band at any time for the uplink. For example, this instruction can be performed according to RRC signaling or system information.

[0453] Thereby, for example, because the plurality of terminal devices **200-3** transmit signals, the signals reach a wider area. Thus, the transmission of a signal using the above-mentioned shared band by the device for performing other wireless communication (for example, wireless LAN communication) can be more reliably suppressed.

[0454] Radio Resource for Transmitting Dummy Signal

[0455] Also, for example, the communication control unit **171** instructs a plurality of terminal devices to transmit the above-mentioned dummy signal in some radio resources among radio resources arranged in a frequency direction across the above-mentioned shared band in at least a symbol in which neither a data signal nor a control signal of the cellular system **1** is transmitted using the above-mentioned shared band for the uplink.

[0456] Specifically, for example, the communication control unit **171** instructs the plurality of terminal devices to transmit the dummy signal. Also, the communication control unit **171** designates a radio resource for transmitting the dummy signal at the time of such an instruction.

[0457] Common Radio Resource

[0458] Some radio resources mentioned above are common among a plurality of terminal devices **200-3**. That is, the communication control unit **171** instructs the plurality of terminal devices **200-3** to transmit the above-mentioned dummy signals in a common radio resource among the above-mentioned plurality of terminal devices **200-3** in at least the above-mentioned symbol for the uplink. Hereinafter, a specific example of the radio resource will be described with reference to FIG. **24**.

[0459] FIG. **24** is an explanatory diagram illustrating a first example of radio resources in which dummy signals are transmitted by the plurality of terminal devices **200-3**.

Referring to FIG. 24, a shared band 71 and RBs arranged across a plurality of slots are illustrated. In this example, the plurality of terminal devices 200-3 transmit the dummy signals in the same RB among the RBs arranged in the frequency direction across the shared band 71 within each slot.

[0460] Thereby, for example, in the cellular system 1, it is possible to allocate more RBs in which no dummy signal is transmitted.

[0461] Separate Radio Resources

[0462] Also, some radio resources mentioned above may be different between at least two of the plurality of terminal devices 200-3. That is, the communication control unit 171 may instruct the at least two of the plurality of terminal devices 200-3 to transmit the above-mentioned dummy signals in different radio resources. Hereinafter, a specific example of the radio resource will be described with reference to FIG. 25.

[0463] FIG. 25 is an explanatory diagram illustrating a second example of radio resources in which dummy signals are transmitted by the plurality of terminal devices 200-3. Referring to FIG. 25, a shared band 71 and RBs arranged across a plurality of slots are illustrated. In this example, first to third terminal devices 200-3 transmit dummy signals in different RBs among the RBs arranged in the frequency direction across the shared band 71 within each slot.

[0464] As described above, the communication control unit 171 controls a wireless communication device for performing the cellular communication so that the above-mentioned wireless communication device transmits a signal using the shared band at any time. Thereby, for example, while a frequency band shared between the cellular communication and other wireless communication (for example, wireless LAN communication) (that is, a shared band) is used in the cellular communication, it is possible to prevent the above-mentioned frequency band from being used in the above-mentioned other wireless communication. Also, according to this technique, for example, a wireless LAN communication device which cannot set the NAV can be prevented from using the above-mentioned frequency band (that is, the shared band).

5.3. Configuration of Base Station

[0465] Next, an example of the configuration of terminal device 200-3 according to the third embodiment will be described with reference to FIG. 26. FIG. 26 is a block diagram illustrating an example of the configuration of the terminal device 200-3 according to the third embodiment. Referring to FIG. 26, the terminal device 200-3 is equipped with an antenna unit 210, a wireless communication unit 220, a storage unit 230, and a processing unit 260.

[0466] Here, the description of the antenna unit 210, the wireless communication unit 220, and the storage unit 230 is not different between the first embodiment and the third embodiment, except for a difference of reference signs. Consequently, here, only the processing unit 260 will be described and redundant description will be omitted.

[0467] (Processing Unit 260)

[0468] The processing unit 260 provides various functions of the terminal device 200-3. The processing unit 260 includes a communication control unit 261. Also, the processing unit 260 can further include another component in addition to the communication control unit 261.

[0469] (Communication Control Unit 261)

[0470] The communication control unit 261 controls the terminal device 200-3 so that the terminal device 200-3 transmits a signal using a shared band at any time for the uplink. The above-mentioned shared band is a frequency band to be shared between cellular communication and other wireless communication.

[0471] Also, the above-mentioned frequency band is an uplink band when an FDD is adopted or downlink and uplink bands when a TDD is adopted.

[0472] (a) Other Wireless Communication and Unit of Time

[0473] For example, the above-mentioned other wireless communication is wireless communication (that is, wireless LAN communication) conforming to the wireless LAN standard.

[0474] Also, for example, the communication control unit 261 controls the terminal device 200-3 so that the terminal device 200-3 transmits a signal using the above-mentioned shared band in each symbol. The above-mentioned symbol is, for example, an SC-FDMA symbol.

[0475] (b) Trigger of Control

[0476] For example, the communication control unit 261 controls the terminal device 200-3 so that the terminal device 200-3 transmits a signal using a shared band at any time according to an instruction by the base station 100-3.

[0477] (c) Transmission Power

[0478] For example, the communication control unit 261 controls the terminal device 200-3 so that transmission power of a signal to be transmitted using the above-mentioned shared band is greater than or equal to predetermined transmission power at any time. Specifically, for example, the communication control unit 261 allocates power greater than or equal to the above-mentioned predetermined transmission power to a signal to be transmitted using the above-mentioned shared band in each symbol. Also, for example, the predetermined transmission power is indicated by the base station 100-3.

[0479] Thereby, for example, in a device for performing other wireless communication (for example, wireless LAN communication), reception power of the above-mentioned signal can reach desired power. As a result, the device can reliably avoid the transmission of a signal using the above-mentioned shared band.

[0480] (d) Technique of Transmission of Signal

[0481] Transmission of Dummy Signal

[0482] For example, the communication control unit 261 controls the terminal device 200-3 so that the terminal device 200-3 transmits a dummy signal using the above-mentioned shared band in at least a symbol in which neither a data signal nor a control signal of the cellular system 1 is transmitted using the above-mentioned shared band. Thereby, for example, it is possible to reliably transmit a signal in each symbol of uplink.

[0483] Also, the description of a specific technique of transmission of a dummy signal by the terminal device 200-3 is the same as the description of the specific technique of transmission of a dummy signal by the base station 100-3 described above, except for a difference related to a link direction (downlink and uplink).

[0484] Consequently, here, redundant description will be omitted.

[0485] As described above, the communication control unit 261 controls the terminal device 200-3 so that the

terminal device **200-3** transmits a signal using the shared band at any time. Thereby, it is possible to prevent a frequency band shared between cellular communication and other wireless communication (for example, wireless LAN communication) (that is, a shared band) from being used in the above-mentioned other wireless communication, for example, while the above-mentioned frequency band is used in the uplink communication.

5.4. Flow of Process

[0486] Next, an example of a process according to the third embodiment will be described with reference to FIGS. **27** and **28**.

[0487] (Process by Base Station)

[0488] FIG. **27** is a flowchart illustrating an example of a schematic flow of a process by the base station **100-3** according to the third embodiment.

[0489] The communication control unit **171** selects a target symbol (**S501**).

[0490] The communication control unit **171** maps a dummy signal to some radio resources among radio resources arranged in the frequency direction across the shared band for the target symbol (**S503**).

[0491] When cellular communication using the shared band has been terminated (**S505**: YES), the process ends. Otherwise (**S505**: NO), the communication control unit **171** selects the next symbol as the target symbol (**S501**).

[0492] (Process by Terminal Device)

[0493] FIG. **28** is a flowchart illustrating an example of a schematic flow of a process by the terminal device **200-3** according to the third embodiment. The process is executed by the terminal device **200-3** according to an instruction by the base station **100-3**.

[0494] The communication control unit **261** selects a target symbol (**S511**).

[0495] The communication control unit **261** maps a dummy signal to some radio resources among radio resources arranged in the frequency direction across the shared band for the target symbol (**S513**).

[0496] When the cellular communication using the shared band has been terminated (**S515**: YES), the process ends. Otherwise (**S515**: NO), the communication control unit **261** selects the next symbol as the target symbol (**S511**).

5.5. Modified Example

Summary

[0497] In the above-mentioned example of the third embodiment, for example, the base station **100-3** instructs the terminal device **200-3** to transmit a signal using a shared band (for example, in each symbol) at any time for the uplink. Also, for example, the terminal device **200-3** transmits a signal using the shared band (for example, in each symbol) at any time according to an instruction by the base station **100-3**.

[0498] On the other hand, in the modified example of the third embodiment, the terminal device **200-3** transmits a signal using the shared band at any time (for example, in each symbol) independently without depending upon the instruction by the base station **100-3**.

[0499] Thereby, for example, while a frequency band shared between cellular communication and other wireless communication (that is, a shared band) is used in wireless

communication between the terminal devices (for example, D2D communication or wireless communication within the LN) in the cellular system, the above-mentioned frequency band can be prevented from being used in the above-mentioned other wireless communication.

[0500] (Terminal Device **200-3**: Communication Control Unit **261**)

[0501] In the modified example of the third embodiment, the communication control unit **261** controls the terminal device **200-3** so that the terminal device **200-3** transmits a signal using the shared band at any time.

[0502] The description of the communication control unit **261** in this regard is the same as the corresponding description for the communication control unit **261** according to the above-mentioned third embodiment, except for differences related to the involvement of a base station and a link direction. Consequently, here, redundant description will be omitted.

[0503] Also, in the above-mentioned example of the third embodiment, for example, the communication control unit **261** controls the terminal device **200-3** so that the terminal device **200-3** transmits a signal using the shared band at any time according to an instruction by the base station **100-3**. On the other hand, in the modified example of the third embodiment, the communication control unit **261** controls the terminal device **200-3** so that the terminal device **200-3** transmits a signal using the shared band at any time independently (for example, in a period in which the shared band is used in the cellular communication).

[0504] Also, in the above-mentioned example of the third embodiment, for example, the communication control unit **261** controls the terminal device **200-3** so that the terminal device **200-3** transmits a signal using the shared band at any time for the uplink. On the other hand, in the modified example of the third embodiment, for example, the communication control unit **261** controls the terminal device **200-3** so that the terminal device **200-3** transmits a signal using a shared band at any time during wireless communication between the terminal devices in the cellular system **1**.

[0505] (Flow of Process)

[0506] An example of the process of the terminal device **200-3** according to the modified example of the third embodiment is the same as the example of the process of the terminal device **200-3** described with reference to FIG. **30**. Consequently, here, redundant description will be omitted.

5.6. Combination of Third Embodiment and First Embodiment/Second Embodiment

Combination of Third Embodiment and First Embodiment

[0507] The third embodiment may be combined with the above-mentioned first embodiment. For example, an operation according to the third embodiment may be applied to the above-mentioned first embodiment.

[0508] For example, the communication control unit **151** of the base station **100-1** may further perform an operation of the communication control unit **171** of the base station **100-3** and the communication control unit **241** of the terminal device **200-1** may further perform an operation of the communication control unit **261** of the terminal device **200-3**.

[0509] Specifically, for example, when the cellular communication is performed using the shared band in the first

embodiment, a technique according to the third embodiment may be used. Specifically, for example, a signal may be transmitted using the shared band at any time (for example, in each symbol) while the cellular communication is performed using the shared band. Thereby, for example, it is possible to more reliably prevent the shared band from being used in the wireless LAN communication while the shared band is used in the cellular communication. For example, a wireless LAN device which cannot set the NAV is also prevented from using the above-mentioned shared band.

[0510] (Combination of Third Embodiment and Second Embodiment)

[0511] The third embodiment may be combined with the above-mentioned second embodiment. For example, an operation according to the third embodiment may be applied to the above-mentioned second embodiment.

[0512] For example, the communication control unit **251** of the terminal device **200-2** may further perform an operation of the communication control unit **171** of the base station **100-3** and/or an operation of the communication control unit **261** of the terminal device **200-2**.

[0513] Specifically, for example, when the cellular communication (for example, wireless communication between terminal devices in the cellular system **1**) is performed using the shared band in the second embodiment, a technique according to the third embodiment may be used. Specifically, for example, a signal may be transmitted using the shared band at any time (for example, in each symbol) while the cellular communication is performed using the shared band. Thereby, for example, it is possible to more reliably prevent the shared band from being used in the wireless LAN communication while the shared band is used in the cellular communication. For example, a wireless LAN device which cannot set the NAV is also prevented from using the above-mentioned shared band.

6. APPLICATIONS

[0514] Technology according to the present disclosure is applicable to various products. For example, the base station **100** may be implemented as a type of eNB such as a macro eNB or a small eNB. The small eNB may be an eNB to cover a cell smaller than a macro cell such as a pico eNB, a micro eNB, or a home (femto) eNB. Conversely, the base station **100** may also be realized as another type of base station, such as a NodeB or a base transceiver station (BTS). The base station **100** may also include a main unit that controls wireless communication (also called a base station device), and one or more remote radio heads (RRHs) placed in a location separate from the main unit. Also, various types of terminals to be described below temporarily or semi-permanently execute a base station function and therefore may operate as the base station **100**.

[0515] In addition, the terminal device **200** may be realized as, for example, a mobile terminal such as a smartphone, a tablet personal computer (PC), a notebook PC, a portable game console, a portable/dongle-style mobile router, or a digital camera, or as an in-vehicle terminal such as a car navigation device. In addition, the terminal device **200** may also be realized as a terminal that conducts machine-to-machine (M2M) communication (also called a machine-type communication (MTC) terminal). Furthermore, at least a part of constituent elements of the terminal

device **200** may be realized as a module mounted onboard these terminals (for example, an integrated circuit module configured on a single die).

6.1. Application Examples Regarding Base Station

First Application Example

[0516] FIG. **31** is a block diagram illustrating a first example of a schematic configuration of an eNB to which the technology of the present disclosure may be applied. An eNB **800** includes one or more antennas **810** and a base station device **820**. Each antenna **810** and the base station device **820** may be connected to each other via an RF cable.

[0517] Each of the antennas **810** includes a single or multiple antenna elements (such as multiple antenna elements included in an MIMO antenna), and is used for the base station device **820** to transmit and receive radio signals. The eNB **800** may include the multiple antennas **810**, as illustrated in FIG. **29**. For example, the multiple antennas **810** may be compatible with multiple frequency bands used by the eNB **800**. Although FIG. **29** illustrates the example in which the eNB **800** includes the multiple antennas **810**, the eNB **800** may also include a single antenna **810**.

[0518] The base station device **820** includes a controller **821**, a memory **822**, a network interface **823**, and a wireless communication interface **825**.

[0519] The controller **821** may be, for example, a CPU or a DSP, and operates various functions of a higher layer of the base station device **820**. For example, the controller **821** generates a data packet from data in signals processed by the wireless communication interface **825**, and transfers the generated packet via the network interface **823**. The controller **821** may bundle data from multiple base band processors to generate the bundled packet, and transfer the generated bundled packet. The controller **821** may have logical functions of performing control such as radio resource control, radio bearer control, mobility management, admission control, and scheduling. The control may be performed in cooperation with an eNB or a core network node in the vicinity. The memory **822** includes RAM and ROM, and stores a program that is executed by the controller **821**, and various types of control data (such as a terminal list, transmission power data, and scheduling data).

[0520] The network interface **823** is a communication interface for connecting the base station device **820** to a core network **824**. The controller **821** may communicate with a core network node or another eNB via the network interface **823**. In that case, the eNB **800**, and the core network node or the other eNB may be connected to each other through a logical interface (such as an S1 interface and an X2 interface). The network interface **823** may also be a wired communication interface or a wireless communication interface for radio backhaul. If the network interface **823** is a wireless communication interface, the network interface **823** may use a higher frequency band for wireless communication than a frequency band used by the wireless communication interface **825**.

[0521] The wireless communication interface **825** supports any cellular communication scheme such as LTE and LTE-Advanced, and provides radio connection to a terminal positioned in a cell of the eNB **800** via the antenna **810**. The wireless communication interface **825** may typically include, for example, a baseband (BB) processor **826** and an RF circuit **827**. The BB processor **826** may perform, for

example, encoding/decoding, modulating/demodulating, and multiplexing/demultiplexing, and performs various types of signal processing of layers (such as L1, medium access control (MAC), radio link control (RLC), and a packet data convergence protocol (PDCP)). The BB processor 826 may have a part or all of the above-mentioned logical functions instead of the controller 821. The BB processor 826 may be a memory that stores a communication control program, or a module that includes a processor and a related circuit configured to execute the program. Updating the program may allow the functions of the BB processor 826 to be changed. The module may be a card or a blade that is inserted into a slot of the base station device 820. Alternatively, the module may also be a chip that is mounted on the card or the blade. Meanwhile, the RF circuit 827 may include, for example, a mixer, a filter, and an amplifier, and transmits and receives radio signals via the antenna 810.

[0522] The wireless communication interface 825 may include the multiple BB processors 826, as illustrated in FIG. 29. For example, the multiple BB processors 826 may be compatible with multiple frequency bands used by the eNB 800. The wireless communication interface 825 may include the multiple RF circuits 827, as illustrated in FIG. 29. For example, the multiple RF circuits 827 may be compatible with multiple antenna elements. Although FIG. 29 illustrates the example in which the wireless communication interface 825 includes the multiple BB processors 826 and the multiple RF circuits 827, the wireless communication interface 825 may also include a single BB processor 826 or a single RF circuit 827.

[0523] Furthermore, in addition to a cellular communication scheme, the wireless communication interface 825 may support a radio LAN communication scheme. In that case, the wireless communication interface 825 may include the BB processor 826 and the RF circuit 827 in the radio LAN communication scheme.

[0524] In the eNB 800 illustrated in FIG. 29, the communication control unit 151 described with reference to FIG. 6 may be implemented in the wireless communication interface 825 (for example, the BB processor). Alternatively, at least a part of the communication control unit 151 may be implemented in the controller 821. As one example, the eNB 800 is equipped with a module including a part (for example, the BB processor 826) or all of the wireless communication interface 825 and/or the controller 821, and the communication control unit 151 may be implemented in the module. In this case, the above-mentioned module may store a program for causing the processor to function as the communication control unit 151 (in other words, a program for causing the processor to execute the operation of the communication control unit 151) and execute the program. As another example, a program for causing the processor to function as the communication control unit 151 is installed in the eNB 800, and the wireless communication interface 825 (for example, the BB processor 826) and/or the controller 821 may execute the program. As mentioned above, the eNB 800, the base station device 820, or the above-mentioned module may be provided as the device including the communication control unit 151, and the program for causing the processor to function as the communication control unit 151 may be provided. Also, a readable storage medium storing the above-mentioned program may be provided. With respect to these points, the communication

control unit 171 described with reference to FIG. 20 are also similar to the communication control unit 151.

[0525] Also, in the eNB 800 illustrated in FIG. 29, the wireless communication unit 120 described with reference to FIG. 6 may be implemented in the wireless communication interface 825 (for example, the RF circuit 827). Also, the antenna unit 110 may be implemented in the antenna 810. Also, the network communication unit 130 may be implemented in the controller 821 and/or the network interface 823.

[0526] (Second Application Example)

[0527] FIG. 30 is a block diagram illustrating a second example of a schematic configuration of an eNB to which the technology of the present disclosure may be applied. An eNB 830 includes one or more antennas 840, a base station device 850, and an RRH 860. Each antenna 840 and the RRH 860 may be connected to each other via an RF cable. The base station device 850 and the RRH 860 may be connected to each other via a high speed line such as an optical fiber cable.

[0528] Each of the antennas 840 includes a single or multiple antenna elements (such as multiple antenna elements included in an MIMO antenna), and is used for the RRH 860 to transmit and receive radio signals. The eNB 830 may include the multiple antennas 840, as illustrated in FIG. 30. For example, the multiple antennas 840 may be compatible with multiple frequency bands used by the eNB 830.

[0529] Although FIG. 30 illustrates the example in which the eNB 830 includes the multiple antennas 840, the eNB 830 may also include a single antenna 840.

[0530] The base station device 850 includes a controller 851, a memory 852, a network interface 853, a wireless communication interface 855, and a connection interface 857. The controller 851, the memory 852, and the network interface 853 are the same as the controller 821, the memory 822, and the network interface 823 described with reference to FIG. 29.

[0531] The wireless communication interface 855 supports any cellular communication scheme such as LTE and LTE-Advanced, and provides wireless communication to a terminal positioned in a sector corresponding to the RRH 860 via the RRH 860 and the antenna 840. The wireless communication interface 855 may typically include, for example, a BB processor 856. The BB processor 856 is the same as the BB processor 826 described with reference to FIG. 29, except the BB processor 856 is connected to the RF circuit 864 of the RRH 860 via the connection interface 857. The wireless communication interface 855 may include the multiple BB processors 856, as illustrated in FIG. 30. For example, the multiple BB processors 856 may be compatible with multiple frequency bands used by the eNB 830. Although FIG. 30 illustrates the example in which the wireless communication interface 855 includes the multiple BB processors 856, the wireless communication interface 855 may also include a single BB processor 856.

[0532] Furthermore, in addition to a cellular communication scheme, the wireless communication interface 855 may support a radio LAN communication scheme. In that case, the wireless communication interface 825 may include the BB processor 856 in the radio LAN communication scheme.

[0533] The connection interface 857 is an interface for connecting the base station device 850 (wireless communication interface 855) to the RRH 860. The connection interface 857 may also be a communication module for

communication in the above-mentioned high speed line that connects the base station device **850** (wireless communication interface **855**) to the RRH **860**.

[0534] The RRH **860** includes a connection interface **861** and a wireless communication interface **863**.

[0535] The connection interface **861** is an interface for connecting the RRH **860** (wireless communication interface **863**) to the base station device **850**. The connection interface **861** may also be a communication module for communication in the above-mentioned high speed line.

[0536] The wireless communication interface **863** transmits and receives radio signals via the antenna **840**. The wireless communication interface **863** may typically include, for example, the RF circuit **864**. The RF circuit **864** may include, for example, a mixer, a filter, and an amplifier, and transmits and receives radio signals via the antenna **840**. The wireless communication interface **863** may include multiple RF circuits **864**, as illustrated in FIG. 30. For example, the multiple RF circuits **864** may support multiple antenna elements. Although FIG. 30 illustrates the example in which the wireless communication interface **863** includes the multiple RF circuits **864**, the wireless communication interface **863** may also include a single RF circuit **864**.

[0537] In the eNB **830** illustrated in FIG. 32, the communication control unit **151** described with reference to FIG. 6 may be implemented in the wireless communication interface **855** (for example, the BB processor). Alternatively, at least a part of the communication control unit **151** may be implemented in the controller **851**. As one example, the eNB **830** is equipped with a module including a part (for example, the BB processor **856**) or all of the wireless communication interface **855** and/or the controller **851**, and the communication control unit **151** may be implemented in the module. In this case, the above-mentioned module may store a program for causing the processor to function as the communication control unit **151** (in other words, a program for causing the processor to execute the operation of the communication control unit **151**) and execute the program. As another example, a program for causing the processor to function as the communication control unit **151** is installed in the eNB **830**, and the wireless communication interface **855** (for example, the BB processor **856**) and/or the controller **851** may execute the program. As mentioned above, the eNB **830**, the base station device **850**, or the above-mentioned module may be provided as the device including the communication control unit **151**, and the program for causing the processor to function as the communication control unit **151** may be provided. Also, a readable storage medium storing the above-mentioned program may be provided. With respect to these points, the communication control unit **171** described with reference to FIG. 20 is also similar to the communication control unit **151**.

[0538] Also, in the eNB **830** illustrated in FIG. 30, the wireless communication unit **120** described, for example, with reference to FIG. 6 may be implemented in the wireless communication interface **863** (for example, the RF circuit **864**). Also, the antenna unit **110** may be implemented in the antenna **840**. Also, the network communication unit **130** may be implemented in the controller **851** and/or the network interface **853**.

[0539] <6.2. Application Examples Regarding Terminal Device>

First Application Example

[0540] FIG. 31 is a block diagram illustrating an example of a schematic configuration of a smartphone **900** to which the technology of the present disclosure may be applied. The smartphone **900** includes a processor **901**, a memory **902**, a storage **903**, an external connection interface **904**, a camera **906**, a sensor **907**, a microphone **908**, an input device **909**, a display device **910**, a speaker **911**, a wireless communication interface **912**, one or more antenna switches **915**, one or more antennas **916**, a bus **917**, a battery **918**, and an auxiliary controller **919**.

[0541] The processor **901** may be, for example, a CPU or a system on a chip (SoC), and controls functions of an application layer and another layer of the smartphone **900**. The memory **902** includes RAM and ROM, and stores a program that is executed by the processor **901**, and data. The storage **903** may include a storage medium such as a semiconductor memory and a hard disk. The external connection interface **904** is an interface for connecting an external device such as a memory card and a universal serial bus (USB) device to the smartphone **900**.

[0542] The camera **906** includes an image sensor such as a charge coupled device (CCD) and a complementary metal oxide semiconductor (CMOS), and generates a captured image. The sensor **907** may include a group of sensors such as a measurement sensor, a gyro sensor, a geomagnetic sensor, and an acceleration sensor. The microphone **908** converts sounds that are input to the smartphone **900** to audio signals. The input device **909** includes, for example, a touch sensor configured to detect touch onto a screen of the display device **910**, a keypad, a keyboard, a button, or a switch, and receives an operation or an information input from a user. The display device **910** includes a screen such as a liquid crystal display (LCD) and an organic light-emitting diode (OLED) display, and displays an output image of the smartphone **900**. The speaker **911** converts audio signals that are output from the smartphone **900** to sounds.

[0543] The wireless communication interface **912** supports any cellular communication scheme such as LTE and LTE-Advanced, and performs wireless communication. The wireless communication interface **912** may typically include, for example, a BB processor **913** and an RF circuit **914**. The BB processor **913** may perform, for example, encoding/decoding, modulating/demodulating, and multiplexing/demultiplexing, and performs various types of signal processing for wireless communication. Meanwhile, the RF circuit **914** may include, for example, a mixer, a filter, and an amplifier, and transmits and receives radio signals via the antenna **916**. The wireless communication interface **912** may also be a one chip module that has the BB processor **913** and the RF circuit **914** integrated thereon. The wireless communication interface **912** may include the multiple BB processors **913** and the multiple RF circuits **914**, as illustrated in FIG. 31. Although FIG. 31 illustrates the example in which the wireless communication interface **912** includes the multiple BB processors **913** and the multiple RF circuits **914**, the wireless communication interface **912** may also include a single BB processor **913** or a single RF circuit **914**.

[0544] Furthermore, in addition to a cellular communication scheme, the wireless communication interface **912** may

support a radio LAN communication scheme. In that case, the wireless communication interface 912 may include the BB processor 913 and the RF circuit 914 in the radio LAN communication scheme. Furthermore, in addition to a cellular communication scheme, the wireless communication interface 912 may support another type of wireless communication scheme such as a short-distance wireless communication scheme and a near field communication scheme. In that case, the wireless communication interface 912 may include the BB processor 913 and the RF circuit 914 for each wireless communication scheme.

[0545] Each of the antenna switches 915 switches connection destinations of the antennas 916 among multiple circuits (such as circuits for different wireless communication schemes) included in the wireless communication interface 912.

[0546] Each of the antennas 916 includes a single or multiple antenna elements (such as multiple antenna elements included in an MIMO antenna), and is used for the wireless communication interface 912 to transmit and receive radio signals. The smartphone 900 may include the multiple antennas 916, as illustrated in FIG. 31. Although FIG. 31 illustrates the example in which the smartphone 900 includes the multiple antennas 916, the smartphone 900 may also include a single antenna 916.

[0547] Furthermore, the smartphone 900 may include the antenna 916 for each wireless communication scheme. In that case, the antenna switches 915 may be omitted from the configuration of the smartphone 900.

[0548] The bus 917 connects the processor 901, the memory 902, the storage 903, the external connection interface 904, the camera 906, the sensor 907, the microphone 908, the input device 909, the display device 910, the speaker 911, the wireless communication interface 912, and the auxiliary controller 919 to each other. The battery 918 supplies power to blocks of the smartphone 900 illustrated in FIG. 31 via feeder lines, which are partially shown as dashed lines in the figure. The auxiliary controller 919 operates a minimum necessary function of the smartphone 900, for example, in a sleep mode.

[0549] In the smartphone 900 illustrated in FIG. 31, the communication control unit 241 described with reference to FIG. 11 may be implemented in the wireless communication interface 912 (for example, the BB processor 913). Alternatively, at least a part of the communication control unit 241 may be implemented in the processor 901 or the auxiliary controller 919. As one example, the smartphone 900 is equipped with a module including a part (for example, the BB processor 913) or all of the wireless communication interface 912, the processor 901 and/or the auxiliary controller 919, and the communication control unit 241 may be implemented in the module. In this case, the above-mentioned module may store a program for causing the processor to function as the communication control unit 241 (in other words, a program for causing the processor to execute the operation of the communication control unit 241) and execute the program. As another example, a program for causing the processor to function as the communication control unit 241 is installed in the smartphone 900, and the wireless communication interface 912 (for example, the BB processor 913), the processor 901, and/or the auxiliary controller 919 may execute the program. As mentioned above, the smartphone 900, the base station device 820, or the above-mentioned module may be provided as the device

including the communication control unit 241, and the program for causing the processor to function as the communication control unit 241 may be provided. Also, a readable storage medium storing the above-mentioned program may be provided. With respect to these points, the communication control unit 251 described with reference to FIG. 19 and the communication control unit 261 described with reference to FIG. 26 are also similar to the communication control unit 241.

[0550] Also, in the smartphone 900 illustrated in FIG. 31, the wireless communication unit 220 described, for example, with reference to FIG. 11 may be implemented in the wireless communication interface 912 (for example, the RF circuit 914). Also, the antenna unit 210 may be implemented in the antenna 916.

Second Application Example

[0551] FIG. 32 is a block diagram illustrating an example of a schematic configuration of a car navigation device 920 to which the technology of the present disclosure may be applied. The car navigation device 920 includes a processor 921, a memory 922, a global positioning system (GPS) module 924, a sensor 925, a data interface 926, a content player 927, a storage medium interface 928, an input device 929, a display device 930, a speaker 931, a wireless communication interface 933, one or more antenna switches 936, one or more antennas 937, and a battery 938.

[0552] The processor 921 may be, for example, a CPU or a SoC, and controls a navigation function and another function of the car navigation device 920. The memory 922 includes RAM and ROM, and stores a program that is executed by the processor 921, and data.

[0553] The GPS module 924 uses GPS signals received from a GPS satellite to measure a position (such as latitude, longitude, and altitude) of the car navigation device 920. The sensor 925 may include a group of sensors such as a gyro sensor, a geomagnetic sensor, and an air pressure sensor. The data interface 926 is connected to, for example, an in-vehicle network 941 via a terminal that is not shown, and acquires data generated by the vehicle, such as vehicle speed data.

[0554] The content player 927 reproduces content stored in a storage medium (such as a CD and a DVD) that is inserted into the storage medium interface 928. The input device 929 includes, for example, a touch sensor configured to detect touch onto a screen of the display device 930, a button, or a switch, and receives an operation or an information input from a user. The display device 930 includes a screen such as a LCD or an OLED display, and displays an image of the navigation function or content that is reproduced. The speaker 931 outputs sounds of the navigation function or the content that is reproduced.

[0555] The wireless communication interface 933 supports any cellular communication scheme such as LET and LTE-Advanced, and performs wireless communication. The wireless communication interface 933 may typically include, for example, a BB processor 934 and an RF circuit 935. The BB processor 934 may perform, for example, encoding/decoding, modulating/demodulating, and multiplexing/demultiplexing, and performs various types of signal processing for wireless communication. Meanwhile, the RF circuit 935 may include, for example, a mixer, a filter, and an amplifier, and transmits and receives radio signals via the antenna 937. The wireless communication interface 933 may be a one chip module having the BB processor 934 and

the RF circuit 935 integrated thereon. The wireless communication interface 933 may include the multiple BB processors 934 and the multiple RF circuits 935, as illustrated in FIG. 32. Although FIG. 32 illustrates the example in which the wireless communication interface 933 includes the multiple BB processors 934 and the multiple RF circuits 935, the wireless communication interface 933 may also include a single BB processor 934 or a single RF circuit 935.

[0556] Furthermore, in addition to a cellular communication scheme, the wireless communication interface 933 may support a radio LAN communication scheme. In that case, the wireless communication interface 933 may include the BB processor 934 and the RF circuit 935 in the radio LAN communication scheme. Furthermore, in addition to a cellular communication scheme, the wireless communication interface 933 may support another type of wireless communication scheme such as a short-distance wireless communication scheme and a near field communication scheme. In that case, the wireless communication interface 933 may include the BB processor 934 and the RF circuit 935 for each wireless communication scheme.

[0557] Each of the antenna switches 936 switches connection destinations of the antennas 937 among multiple circuits (such as circuits for different wireless communication schemes) included in the wireless communication interface 933.

[0558] Each of the antennas 937 includes a single or multiple antenna elements (such as multiple antenna elements included in an MIMO antenna), and is used for the wireless communication interface 933 to transmit and receive radio signals. The car navigation device 920 may include the multiple antennas 937, as illustrated in FIG. 32. Although FIG. 32 illustrates the example in which the car navigation device 920 includes the multiple antennas 937, the car navigation device 920 may also include a single antenna 937.

[0559] Furthermore, the car navigation device 920 may include the antenna 937 for each wireless communication scheme. In that case, the antenna switches 936 may be omitted from the configuration of the car navigation device 920.

[0560] The battery 938 supplies power to blocks of the car navigation device 920 illustrated in FIG. 32 via feeder lines that are partially shown as dashed lines in the figure. The battery 938 accumulates power supplied from the vehicle.

[0561] In the car navigation device 920 illustrated in FIG. 32, the communication control unit 241 described with reference to FIG. 11 may be implemented in the wireless communication interface 933 (for example, the BB processor 934).

[0562] Alternatively, at least a part of the communication control unit 241 may be implemented in the processor 921. As one example, the car navigation device 920 is equipped with a module including a part (for example, the BB processor 934) or all of the wireless communication interface 933, and/or processor 921, and the communication control unit 241 may be implemented in the module. In this case, the above-mentioned module may store a program for causing the processor to function as the communication control unit 241 (in other words, a program for causing the processor to execute the operation of the communication control unit 241) and execute the program. As another example, a program for causing the processor to function as the communication control unit 241 is installed in the car

navigation device 920, and the wireless communication interface 933 (for example, the BB processor 934), and/or the processor 921 may execute the program. As mentioned above, the car navigation device 920, the base station device 820, or the above-mentioned module may be provided as the device including the communication control unit 241, and the program for causing the processor to function as the communication control unit 241 may be provided. Also, a readable storage medium storing the above-mentioned program may be provided. With respect to these points, the communication control unit 251 described with reference to FIG. 19 and the communication control unit 261 described with reference to FIG. 26 are also similar to the communication control unit 241.

[0563] Also, in the car navigation device 920 illustrated in FIG. 32, the wireless communication unit 220 described, for example, with reference to FIG. 11 may be implemented in the wireless communication interface 933 (for example, the RF circuit 935). Also, the antenna unit 210 may be implemented in the antenna 937.

[0564] The technology of the present disclosure may also be realized as an in-vehicle system (or a vehicle) 940 including one or more blocks of the car navigation device 920, the in-vehicle network 941, and a vehicle module 942. That is, the in-vehicle system (or the vehicle) 940 may be provided as a device including the communication control unit 241 (or the communication control unit 251 or 261). The vehicle module 942 generates vehicle data such as vehicle speed, engine speed, and trouble information, and outputs the generated data to the in-vehicle network 941.

7. CONCLUSION

[0565] The devices and the processes according to the embodiments of the present disclosure have been described with reference to FIGS. 1 to 32.

First Embodiment

[0566] According to the first embodiment, through control by the base station 100-1, the wireless communication device for performing the cellular communication transmits a frame including duration information for setting an NAV using a frequency band shared between the cellular communication and wireless LAN communication. Through control by the base station 100-1, the cellular communication is performed using the above-mentioned frequency band in a period after the transmission of the above-mentioned frame. Also, the above-mentioned wireless communication device is the base station 100-1 or the terminal device 200-1.

[0567] Thereby, for example, while the frequency band shared between the cellular communication and the wireless LAN communication is used in wireless communication between the terminal devices in the cellular system, the above-mentioned frequency band can be prevented from being used in wireless LAN communication.

Second Embodiment

[0568] According to the second embodiment, through control by the terminal device 200-2, a wireless communication device for performing cellular communication transmits a frame including duration information for setting an NAV using a frequency band shared between the cellular communication and wireless LAN communication. Through

control by the terminal device **200-2**, the cellular communication is performed using the above-mentioned shared band in a period after the transmission of the above-mentioned frame. Also, the above-mentioned wireless communication device is the terminal device **200-2** or another terminal device **200-2**.

[0569] Thereby, for example, while the frequency band shared between the cellular communication and the wireless LAN communication is used in wireless communication between the terminal devices in the cellular system, the above-mentioned frequency band can be prevented from being used in wireless LAN communication.

Third Embodiment

[0570] According to the third embodiment, a wireless communication device for performing cellular communication is controlled so that the above-mentioned wireless communication device transmits a signal using a frequency band (that is, shared band) shared between the cellular communication and other wireless communication.

[0571] Thereby, for example, a frequency band shared between the cellular communication and the other wireless communication (for example, wireless LAN communication) can be prevented from being used in the above-mentioned other wireless communication while the frequency band is used for the cellular communication.

[0572] As described above, according to the embodiment of the present disclosure, for example, it is possible to more appropriately use a frequency band shared between wireless communication of a cellular system and other wireless communication in the above-mentioned cellular system.

[0573] The preferred embodiment(s) of the present disclosure has/have been described above with reference to the accompanying drawings, whilst the present disclosure is not limited to the above examples, of course. A person skilled in the art may find various alterations and modifications within the scope of the appended claims, and it should be understood that they will naturally come under the technical scope of the present disclosure.

[0574] Although an example in which the cellular system is a system conforming to LTE, LTE-Advanced, or a compliant communication scheme has been described, the present disclosure is not limited to such an example. For example, the communication system may be a system conforming to another communication standard.

[0575] Also, for example, an example in which other wireless communication different from wireless communication of the cellular system is wireless LAN communication (that is, wireless communication conforming to the wireless LAN standard) has been described, but the present disclosure is not limited to the relevant examples. For example, the above-mentioned other wireless communication may be wireless communication (wireless communication conforming to another communication standard adopting CSMA) other than the wireless LAN communication.

[0576] Also, the processing steps in each process in this specification are not strictly limited to execution in a time series following the sequence described in a flowchart or a sequence diagram. For example, the processing steps in each process may be executed in a sequence that differs from a sequence described herein as a flowchart or a sequence diagram, and furthermore may be executed in parallel.

[0577] Also, it is possible to create a computer program for causing the processor (for example, a CPU, a DSP, etc.)

provided in a device (for example, the base station and/or the terminal device) of the present description to function as the components (for example, the communication control unit) of the above-mentioned device (in other words, a computer program for causing the above-mentioned processor to execute the operation of the components of the above-mentioned device). Also, a storage medium storing the computer program may be provided. Also, a device (for example, a completed product or a module (a component, a processing circuit, a chip, etc.) for a completed product) including a memory that stores the above-mentioned computer program and one or more processors capable of executing the above-mentioned computer program may be provided. Also, a method including the operation of the components of the above-mentioned device (for example, the communication control unit) is included in the technology according to the present disclosure.

[0578] In addition, the advantageous effects described in this specification are merely for the sake of explanation or illustration, and are not limiting. In other words, instead of or in addition to the above advantageous effects, technology according to the present disclosure may exhibit other advantageous effects that are clear to persons skilled in the art from the description of this specification.

[0579] Additionally, the present technology may also be configured as below.

(1)

[0580] A device including:

[0581] a control unit configured to control a wireless communication device for performing wireless communication of a cellular system so that the wireless communication device transmits a frame including duration information for setting a network allocation vector (NAV) using a frequency band shared between the wireless communication of the cellular system and wireless communication conforming to a wireless local area network (LAN) standard,

[0582] wherein the control unit controls a base station of the cellular system so that the wireless communication of the cellular system is performed using the frequency band in a period after the transmission of the frame.

(2)

[0583] The device according to (1), wherein the wireless communication device includes the base station.

(3)

[0584] The device according to (2), wherein the period is a period which starts at a point in time at which a short inter-frame space (SIFS) has elapsed from an end time-point of the transmission of the frame.

(4)

[0585] The device according to (2), wherein the frame is a frame for causing another frame including the duration information for setting the NAV to be transmitted to a specific device for receiving the frame.

(5)

[0586] The device according to (4),

[0587] wherein the frame is a request to send (RTS) frame, and

[0588] wherein the other frame is a clear to send (CTS) frame.

(6)

[0589] The device according to (4) or (5), wherein the period is a period after the transmission of the other frame.

(7)

[0590] The device according to (1) or (2), wherein the wireless communication device includes a terminal device for performing wireless communication of the cellular system.

(8)

[0591] The device according to (7), wherein the control unit instructs the terminal device to transmit the frame using the frequency band.

(9)

[0592] The device according to (8), wherein, the control unit uses another frequency band for the cellular system to instruct the terminal device to transmit the frame using the frequency band.

(10)

[0593] The device according to (8) or (9), wherein the control unit provides the terminal device with information which specifies a timing at which the frame is transmitted.

(11)

[0594] The device according to any one of (8) to (10), wherein the control unit provides the terminal device with the duration information or information which specifies the duration information.

(12)

[0595] The device according to any one of (1) to (11), wherein the duration information indicates a duration which covers at least the period.

(13)

[0596] The device according to any one of (1) to (12), wherein the frame is an RTS frame or a CTS frame.

(14)

[0597] The device according to any one of (1) to (13), wherein the control unit controls a wireless communication device for performing wireless communication of the cellular system so that the wireless communication device transmits a signal using the frequency band at any time during the period.

(15)

[0598] The device according to any one of (1) to (14), wherein the device is the base station, a base station device for the base station, or a module for the base station device.

(16)

[0599] A device including:

[0600] a control unit configured to control a terminal device for performing wireless communication of a cellular system so that the terminal device transmits a frame including duration information for setting a NAV using a frequency band shared between the wireless communication of the cellular system and wireless communication conforming to a wireless LAN standard according to an instruction from a base station of the cellular system.

(17)

[0601] A device including:

[0602] a control unit configured to control a wireless communication device for performing wireless communication of a cellular system so that the wireless communication device transmits a frame including duration information for setting a NAV using a frequency band shared between the wireless communication of the cellular system and wireless communication conforming to a wireless LAN standard,

[0603] wherein the control unit controls a terminal device for performing wireless communication of the cellular system so that the wireless communication of the cellular

system is performed using the frequency band in a period after the transmission of the frame.

(18)

[0604] The device according to (17), wherein the control unit controls the terminal device so that wireless communication between terminal devices in the cellular system is performed using the frequency band in the period.

(19)

[0605] A device including:

[0606] a control unit configured to control a wireless communication device for performing wireless communication of a cellular system so that the wireless communication device transmits a signal using a frequency band shared between the wireless communication of the cellular system and other wireless communication at any time.

(20)

[0607] The device according to (19), wherein the control unit controls the wireless communication device so that a transmission power of a signal to be transmitted using the frequency band is greater than or equal to a predetermined transmission power at any time.

(21)

[0608] The device according to (19) or (20), wherein the control unit controls the wireless communication device so that the wireless communication device transmits the signal using the frequency band in each symbol.

(22)

[0609] The device according to (21), wherein the control unit controls the wireless communication device so that the wireless communication device transmits a dummy signal using the frequency band in at least a symbol in which neither a data signal nor a control signal of the cellular system are transmitted using the frequency band.

(23)

[0610] The device according to (22), wherein the control unit controls the wireless communication device so that the wireless communication device transmits the dummy signal in some radio resources among radio resources arranged in a frequency direction across the frequency band in at least the symbol.

(24)

[0611] The device according to (23), wherein the some radio resources are some resource blocks among resource blocks arranged in the frequency direction across the frequency band.

(25)

[0612] The device according to (23), wherein the some radio resources are some resource elements included in each resource block arranged in the frequency direction across the frequency band.

(26)

[0613] The device according to any one of (19) to (25),
[0614] wherein the device is a base station for performing wireless communication of the cellular system, a base station device for the base station, or a module for the base station device, and

[0615] wherein the control unit instructs a terminal device for performing wireless communication of the cellular system to transmit the signal using the frequency band at any time for an uplink.

(27)

[0616] The device according to (26), wherein the control unit instructs each of a plurality of terminal devices for

performing wireless communication of the cellular system to transmit the signal using the frequency band at any time for the uplink.

(28)

[0617] The device according to (26) or (27),

[0618] wherein the control unit instructs a plurality of terminal devices to transmit a dummy signal in some radio resources among radio resources arranged in a frequency direction across the frequency band in at least a symbol in which neither a data signal nor a control signal of the cellular system are transmitted using the frequency band for the uplink, and

[0619] wherein the some radio resources are common among the plurality of terminal devices.

(29)

[0620] The device according to any one of (19) to (25),

[0621] wherein the device is a terminal device for performing wireless communication of the cellular system or a module for the terminal device, and

[0622] wherein the control unit controls the terminal device so that the terminal device transmits the signal using the frequency band at any time for an uplink.

(30)

[0623] The device according to any one of (19) to (25), wherein the device is a base station for performing wireless communication of the cellular system, a base station device for the base station, or a module for the base station device.

(31)

[0624] The device according to any one of (19) to (25), wherein the device is a terminal device for performing wireless communication of the cellular system or a module for the terminal device.

(32)

[0625] The device according to any one of (1) to (16), (19) to (25), and (30),

[0626] wherein a duplex operation of the cellular system is frequency division duplex (FDD), and

[0627] wherein the frequency band is used as a downlink band in the cellular system.

(33)

[0628] A method including:

[0629] controlling, by a processor, a wireless communication device for performing wireless communication of a cellular system so that the wireless communication device transmits a frame including duration information for setting a network allocation vector (NAV) using a frequency band shared between the wireless communication of the cellular system and wireless communication conforming to a wireless local area network (LAN) standard; and

[0630] controlling, by a processor, a base station of the cellular system so that the wireless communication of the cellular system is performed using the frequency band in a period after the transmission of the frame.

(34)

[0631] A program for causing a processor to execute:

[0632] controlling a wireless communication device for performing wireless communication of a cellular system so that the wireless communication device transmits a frame including duration information for setting a network allocation vector (NAV) using a frequency band shared between the wireless communication of the cellular system and wireless communication conforming to a wireless local area network (LAN) standard; and

[0633] controlling a base station of the cellular system so that the wireless communication of the cellular system is performed using the frequency band in a period after the transmission of the frame.

(35)

[0634] A readable recording medium having a program recorded thereon, the program causing a processor to execute:

[0635] controlling a wireless communication device for performing wireless communication of a cellular system so that the wireless communication device transmits a frame including duration information for setting a network allocation vector (NAV) using a frequency band shared between the wireless communication of the cellular system and wireless communication conforming to a wireless local area network (LAN) standard; and

[0636] controlling a base station of the cellular system so that the wireless communication of the cellular system is performed using the frequency band in a period after the transmission of the frame.

(36)

[0637] A method including:

[0638] controlling, by a processor, a terminal device for performing wireless communication of a cellular system so that the terminal device transmits a frame including duration information for setting a NAV using a frequency band shared between the wireless communication of the cellular system and wireless communication conforming to a wireless LAN standard according to an instruction from a base station of the cellular system.

(37)

[0639] A program for causing a processor to execute:

[0640] controlling a terminal device for performing wireless communication of a cellular system so that the terminal device transmits a frame including duration information for setting a NAV using a frequency band shared between the wireless communication of the cellular system and wireless communication conforming to a wireless LAN standard according to an instruction from a base station of the cellular system.

(38)

[0641] A readable recording medium having a program recorded thereon, the program causing a processor to execute:

[0642] controlling a terminal device for performing wireless communication of a cellular system so that the terminal device transmits a frame including duration information for setting a NAV using a frequency band shared between the wireless communication of the cellular system and wireless communication conforming to a wireless LAN standard according to an instruction from a base station of the cellular system.

(39)

[0643] A method including:

[0644] controlling, by a processor, a wireless communication device for performing wireless communication of a cellular system so that the wireless communication device transmits a frame including duration information for setting a NAV using a frequency band shared between the wireless communication of the cellular system and wireless communication conforming to a wireless LAN standard; and

[0645] controlling, by a processor, a terminal device for performing wireless communication of the cellular system

so that the wireless communication of the cellular system is performed using the frequency band in a period after the transmission of the frame.

(40)

[0646] A program for causing a processor to execute:

[0647] controlling a wireless communication device for performing wireless communication of a cellular system so that the wireless communication device transmits a frame including duration information for setting a NAV using a frequency band shared between the wireless communication of the cellular system and wireless communication conforming to a wireless LAN standard; and

[0648] controlling a terminal device for performing wireless communication of the cellular system so that the wireless communication of the cellular system is performed using the frequency band in a period after the transmission of the frame.

(41)

[0649] A readable recording medium having a program recorded thereon, the program causing a processor to execute:

[0650] controlling a wireless communication device for performing wireless communication of a cellular system so that the wireless communication device transmits a frame including duration information for setting a NAV using a frequency band shared between the wireless communication of the cellular system and wireless communication conforming to a wireless LAN standard; and

[0651] controlling a terminal device for performing wireless communication of the cellular system so that the wireless communication of the cellular system is performed using the frequency band in a period after the transmission of the frame.

(42)

[0652] A method including:

[0653] controlling, by a processor, a wireless communication device for performing wireless communication of a cellular system so that the wireless communication device transmits a signal using a frequency band shared between the wireless communication of the cellular system and other wireless communication at any time.

(43)

[0654] A program for causing a processor to execute:

[0655] controlling a wireless communication device for performing wireless communication of a cellular system so that the wireless communication device transmits a signal using a frequency band shared between the wireless communication of the cellular system and other wireless communication at any time.

(44)

[0656] A readable recording medium having a program recorded thereon, the program causing a processor to execute:

[0657] controlling a wireless communication device for performing wireless communication of a cellular system so that the wireless communication device transmits a signal using a frequency band shared between the wireless communication of the cellular system and other wireless communication at any time.

REFERENCE SIGNS LIST

[0658] 1 cellular system
[0659] 10 cell
[0660] 30 access point

[0661] 40 communication area
[0662] 50 terminal device
[0663] 71 shared band
[0664] 100 base station
[0665] 151, 171 communication control unit
[0666] 200 terminal device
[0667] 241, 251, 261 communication control unit

1: A device comprising:

circuitry configured to control a wireless communication device for performing wireless communication of a cellular system so that the wireless communication device transmits a frame including duration information for setting a network allocation vector (NAV) using a frequency band shared between the wireless communication of the cellular system and wireless communication conforming to a wireless local area network (LAN) standard,

wherein the circuitry controls a base station of the cellular system so that the wireless communication of the cellular system is performed using the frequency band in a period after the transmission of the frame.

2: The device according to claim 1, wherein the wireless communication device includes the base station.

3: The device according to claim 2, wherein the period is a period which starts at a point in time at which a short inter-frame space (SIFS) has elapsed from an end time-point of the transmission of the frame.

4: The device according to claim 2, wherein the frame is a frame for causing another frame including the duration information for setting the NAV to be transmitted to a specific device for receiving the frame.

5: The device according to claim 4,

wherein the frame is a request to send (RTS) frame, and wherein the other frame is a clear to send (CTS) frame.

6: The device according to claim 4, wherein the period is a period after the transmission of the other frame.

7: The device according to claim 1, wherein the wireless communication device includes a terminal device for performing wireless communication of the cellular system.

8: The device according to claim 7, wherein the circuitry instructs the terminal device to transmit the frame using the frequency band.

9: The device according to claim 8, wherein, the circuitry uses another frequency band for the cellular system to instruct the terminal device to transmit the frame using the frequency band.

10: The device according to claim 8, wherein the circuitry provides the terminal device with information which specifies a timing at which the frame is transmitted.

11: The device according to claim 8, wherein the circuitry provides the terminal device with the duration information or information which specifies the duration information.

12: The device according to claim 1, wherein the duration information indicates a duration which covers at least the period.

13: The device according to claim 1, wherein the frame is an RTS frame or a CTS frame.

14: The device according to claim 1, wherein the circuitry controls a wireless communication device for performing wireless communication of the cellular system so that the wireless communication device transmits a signal using the frequency band at any time during the period.

15: The device according to claim **1**, wherein the device is the base station, a base station device for the base station, or a module for the base station device.

16: A device comprising:

circuitry configured to control a terminal device for performing wireless communication of a cellular system so that the terminal device transmits a frame including duration information for setting a NAV using a frequency band shared between the wireless communication of the cellular system and wireless communication conforming to a wireless LAN standard according to an instruction from a base station of the cellular system.

17: A device comprising:

circuitry configured to control a wireless communication device for performing wireless communication of a cellular system so that the wireless communication

device transmits a frame including duration information for setting a NAV using a frequency band shared between the wireless communication of the cellular system and wireless communication conforming to a wireless LAN standard,

wherein the circuitry controls a terminal device for performing wireless communication of the cellular system so that the wireless communication of the cellular system is performed using the frequency band in a period after the transmission of the frame.

18-31. (canceled)

32: The device according to claim **1**,

wherein a duplex operation of the cellular system is frequency division duplex (FDD), and wherein the frequency band is used as a downlink band in the cellular system.

* * * * *