

E. BROWN.
MACHINE FOR MAKING HINGES.

No. 10,943.

Patented May 16, 1854.

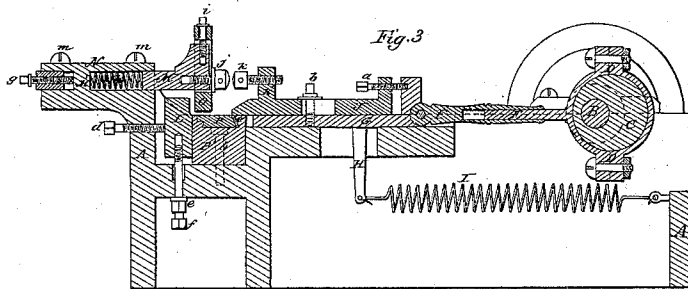
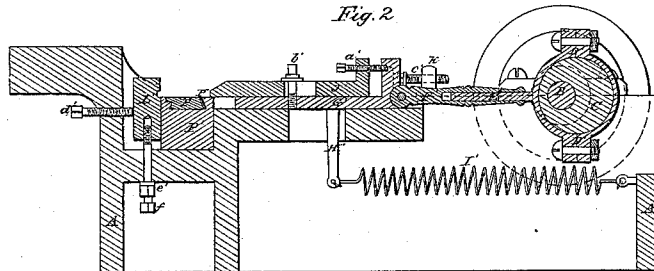
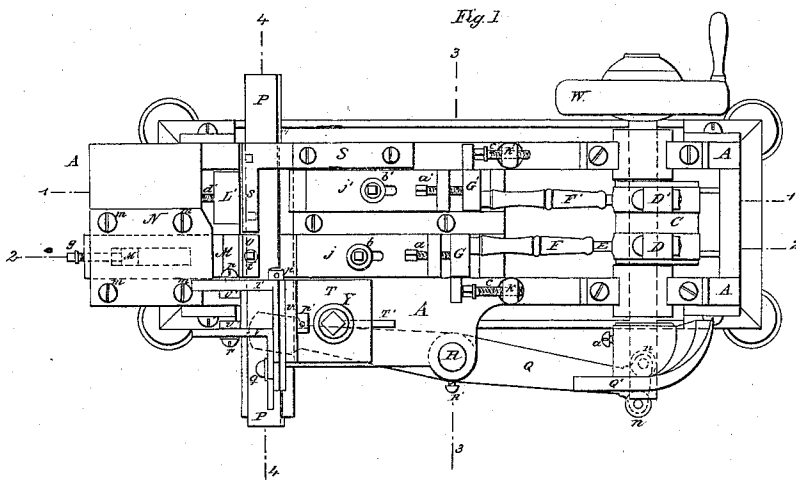

E. BROWN.
MACHINE FOR MAKING HINGES.

No. 10,943.

Patented May 16, 1854.

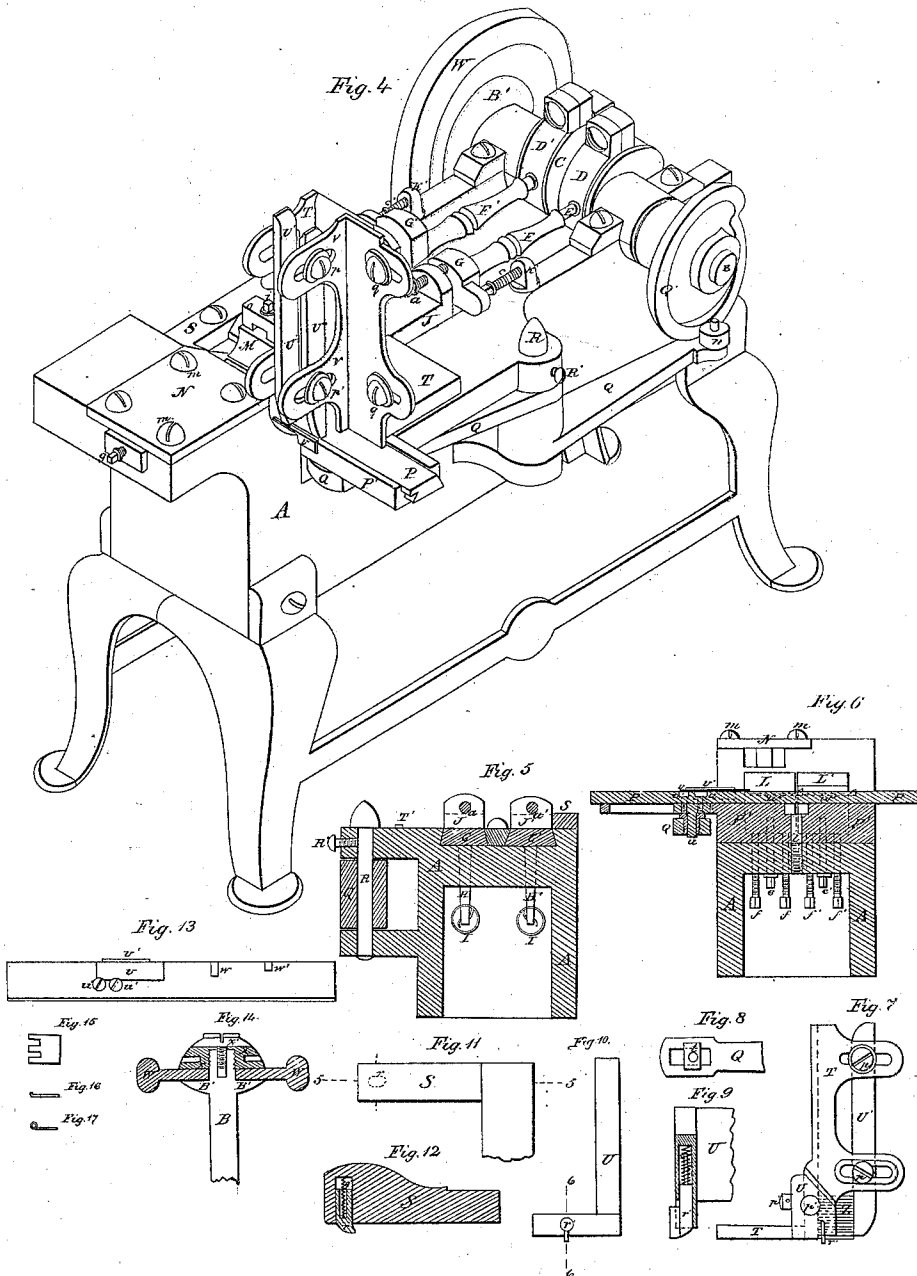

UNITED STATES PATENT OFFICE.

EDWARD BROWN, OF WATERBURY, CONNECTICUT, ASSIGNOR TO THE SCOVILL
MANUFACTURING CO.

MACHINE FOR MAKING HINGES.

Specification of Letters Patent No. 10,943, dated May 16, 1854.

To all whom it may concern:

Be it known that I, EDWARD BROWN, of the city of Waterbury, in the county of New Haven, in the State of Connecticut, have invented a new and useful Improvement in Machinery for Making Hinges; and I do hereby declare that the following is a full and exact description thereof.

The nature of my invention consists in providing machinery furnished with feeding-ways into which the skeleton hinges, previously cut out to the required form, are placed, and then introduced, one by one, by means of a feeding-slide, before dies where the knuckles are turned, by means of punches, and the finished hinges then ejected from the machine.

To enable others skilled in the art, to make and use my invention I will proceed to describe its construction and operation, reference being had to the annexed drawings forming a part of this specification, in which—

Figure 1, is a top view. Fig. 2, is a longitudinal vertical section drawn through the lines 1, 1, in Fig. 1. Fig. 3 is a similar view drawn through the lines 2, 2, in Fig. 1. Fig. 4 is a perspective view of a complete machine. Fig. 5, is a vertical cross section through lines 3, 3 in Fig. 1. Fig. 6, is a similar view through lines 4, 4, in Fig. 1. Fig. 7, is a side-view of the feeding-ways. Fig. 8 shows the manner of attaching the end of the lever *q* to the feeding-slide. Fig. 9 is a view of the preventor in the feeding-ways. Fig. 10 is a bottom-view of the preventor. Fig. 11, is a top-view of gage, *S*, showing the position of the preventor *r'*. Fig. 12 is a vertical section of the same through lines 5, 5 in Fig. 11. Fig. 13 is a top-view of the feeding-slide. Fig. 14 is a sectional view of the band-wheel with frictional coupling; Fig. 15, skeleton hinge before being operated upon by the machine. Fig. 16, appearance of hinge after having received the first curve; Fig. 17, the knuckle completed.

Similar letters refer to like parts.

A is the frame.

B is the driving-shaft; B', shoulder on shaft B.

C is the eccentric.

D D' are the eccentric bands; E E', sliding-rod of eccentric; F F', hollow eccentric rods; G G', slides moved by eccentrics;

H H', arms attached to slides G G'; I I', springs attached to H H'; J J', sliding punches; K K', studs fastened to frame A; L L', dies; M, sliding gage; M', stud; N, top-plate; O, vertical slide; P, feeding-slide; P', bed of feeding-slide; P'', gip; Q, feeding-lever; Q', cam; R, center pin of lever Q; R', set-screw; S, fast gage; T, bottom part of the feeding-ways; T', feather of sliding-ways; U, adjustable feeding-gage; U', adjustable side-piece of feeding-ways; V, angular adjustable side-piece of feeding-ways; W, band-wheel; X, friction-nut; X', jam-screw.

Y is a bolt.

Z shows the plates; *a a'*, set-screws; *b b'*, bolts; *c c'*, set-screws; *d d'*, set-screws; *e e'*, bolts; *f f'*, set-screws; *g*, set-screws; *h*, spiral spring; *i*, set-screw; *j*, bolt; *k*, set-screw; *l'*, stud for set-screw *k*; *l*, bolt; *m*, bolts; *n*, rollers on lever Q; *o*, set-screw; *p p'*, bolts; *q*, bolts; *q'*, spiral spring; *r r'*, preventors; *s*, spiral springs; *t*, self-adjustable slide; *u*, pin; *u'*, bolts; *v*, catches; *v'*, shoulder; *w w'*, spring-catches.

The skeleton hinges Z having been placed within the feeding-ways U U', *b b'* and T, in a horizontal position one above the other, motion is communicated to the band-wheel, W, which imparts movement, by means of the shaft B, to the cam Q'. Consequently the lever Q is made to move upon its axis R with a vibrating motion; and the lever Q being connected with the feeding-slide in the manner shown at Fig. 6 and Fig. 8 a horizontal movement is imparted to the slide P. The lower hinge is now carried by the catcher *v*, out of the feeding-ways, before the die L. The sliding-punch J, operated by eccentric C now comes up and presses the hinge against the die L, and gives it the first curve, as shown in Fig. 16. At the next revolution of the shaft the feeding-slide returns, and the catcher *v* takes another hinge, the previous hinge being retained by spring-catcher *w* in front of the die L', where the hinge Z receives the finishing turn, by means of the sliding-punch J' in the manner as shown at Fig. 17. At the third revolution of shaft B this hinge is again prevented from returning with the feeding-slide P by means of the preventor *r* (Figs. 11 and 12); and the spring-catcher *w'* carries it out of the machine.

Dies L L' are adjustable by screws $f f'$, and bolts $e e'$ draw them down to these set screws, while bolts d and d' fasten the dies against bed P'. To prevent plate Z from rising while the plate Z is in front of the die L, gage O is used, which is adjustable by set-screw i and bolt j to the thickness of the plate Z. This gage O has also a motion lengthwise which is also used to insure the correct curving of plate Z. When punch J advances, set-screw K comes in contact with bolt j and pushes slide M and gage O forward, spring h throws it back, and set-screw, g , determines the length of the motion.

Punches J J' are adjustable to the width of plate Z by set screws a and a' which bear against an upright shoulder on slides G G' in Figs. 1 and 2. The length of the motion of punches J and J' can be adjusted by set-screws c and c' in Figs. 1 and 2 which work in studs K and K' and strike against a lip extending from slides G G'. The slides G G' are worked by the eccentric, C, having rods E E' sliding within hollow rods F F'. These hollow rods are hinged to the slides G G'. To the lower parts of the slides G G' are attached arms H H'; and to the lower ends of these arms spiral springs I I' are fastened. When the revolution of the cam has pushed forward the eccentric rods E E' and with them the slides G G' the springs suddenly withdraw the slides G G' as fast as the eccentric permits, until the slides G G' come in contact with set-screws c and c' .

Fig. 14 shows the arrangement of the adjustable friction coupling. The pulley or gear W is placed on the shaft B against the shoulder B'. The friction nut X is now screwed up against the pulley or gear so tight as to give friction enough to the pulley or gear to drive the machinery. The jam-screw X' is now screwed up against the nut X and holds the nut X in its position. Now if by an accident or other cause the machinery becomes deranged, or any foreign substance should intervene to prevent the proper operation of the machinery, the work is entirely stopped by the pulley W becoming a loose pulley. Thus it will be perceived that by means of the adjustable friction coupling more or less power may be communicated to the machinery as may be desired.

The feeding-ways seen in Figs. 1, 4, and 7 consist of an upright piece T having slots on one side through which the set-screws, p

pass. These set-screws p sustain an upright piece U' which is adjustable to the width of the plates. b , is another adjustable side of the feeding-ways having slots on each of its sides with bolts p and q . The bolts fasten on to T. The bolts p sustain an upright piece U'. The four pieces T, U' and b form an adjustable feeding-box which requires to be gaged in such manner as to accommodate the sizes of the hinge that is desired to be retained by them.

The lower part of the upright piece Fig. 7 is furnished with an angular gage U, in which the preventor r' works. This angular gage is regulated by the set-screws p' by means of which it can be adjusted to the thickness of the hinges; and set so that only one plate can pass through on to the feeding-slide at one time.

The frame A where the feeding-ways stand is furnished with a feather T' having a corresponding groove i the bottom part of the upright piece T. The bottom part of the upright piece has a slot through which a bolt, Y, passes by means of which the entire ways are fastened to the frame A. The bolt, Y, permits a longitudinal adjustment of the ways.

Having thus described my invention I claim:—

1. I claim the slides G G', regulated by set screws, substantially as described.
2. I claim the eccentric rods E, E', sliding within the hollow rods F, F', and connected with the slides G G'.
3. I claim the sliding punches J, J', with adjusting-screws, arranged as set forth.
4. I claim the sliding-gage, O, with its longitudinal motion and set screws, for the purpose of securing the hinges while turning the knuckle, in the manner substantially as set forth.
5. I claim the fast gage, S, with the preventor r .
6. I claim the slide P, with the catcher v and the spring-catchers w, w' .
7. I claim the gage U, in combination with the preventor r' , for the purpose of preventing the hinge from returning with the feeding-slide; the whole being arranged and combined in the manner set forth, or in any other manner substantially the same.

EDWARD BROWN.

In presence of—

G. L. TOWNSEND,
THEODORE S. BUEL.