

(21) Application No: 1419226.4  
 (22) Date of Filing: 29.10.2014

(51) INT CL:  
 E06B 3/663 (2006.01)

(71) Applicant(s):  
**Bostik Limited**  
 (Incorporated in the United Kingdom)  
 Ulverscroft Road, Leicester LE4 6BW,  
 United Kingdom

(56) Documents Cited:  
**GB 2070119 A**                      **GB 1159001 A**  
**EP 0113209 A**                      **WO 2004/106690 A**  
**DE 002620964 A**                      **FR 001079389 A**  
**NL 007603812 A**

(72) Inventor(s):  
**Peadar Sefia McCready**  
**Alex Demetriou**

(58) Field of Search:  
 INT CL **E06B**  
 Other: **WPI EPODOC**

(74) Agent and/or Address for Service:  
**Patent Outsourcing Limited**  
 1 King Street, BAKEWELL, Derbyshire, DE45 1DZ,  
 United Kingdom

(54) Title of the Invention: **Spacer bar to improve gas barrier in insulated glass unit**  
 Abstract Title: **Spacer bar to improve gas barrier in an insulated glazing unit**

(57) A spacer bar for use in an insulated glazing unit (IGU) has an elongate strip 230 forming an external wall and two side wall strips (224, 226) mounted perpendicular to the wall. The side walls are spaced apart to form a cavity 222, and are positioned inward of the edges of the external wall to each provide a ledge (232, 234) for accommodating a glazing pane (212, 214). Another strip 220 may be located across the free edges of the side walls to enclose the cavity. The enclosure may contain a desiccant material, and the covering strip may also include perforations 236 that allow the flow of gas to and from the enclosure. The ledges and outer faces of the side wall can be coated with an adhesive or sealant (240, 242) for adhering glass panes. Also disclosed is an IGU including the spacer bar and its method of manufacture.

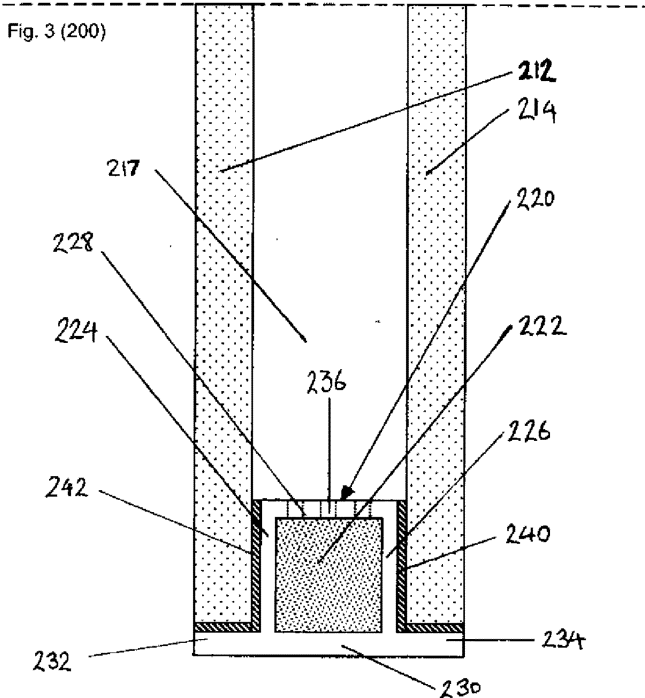

Fig. 1 (10)

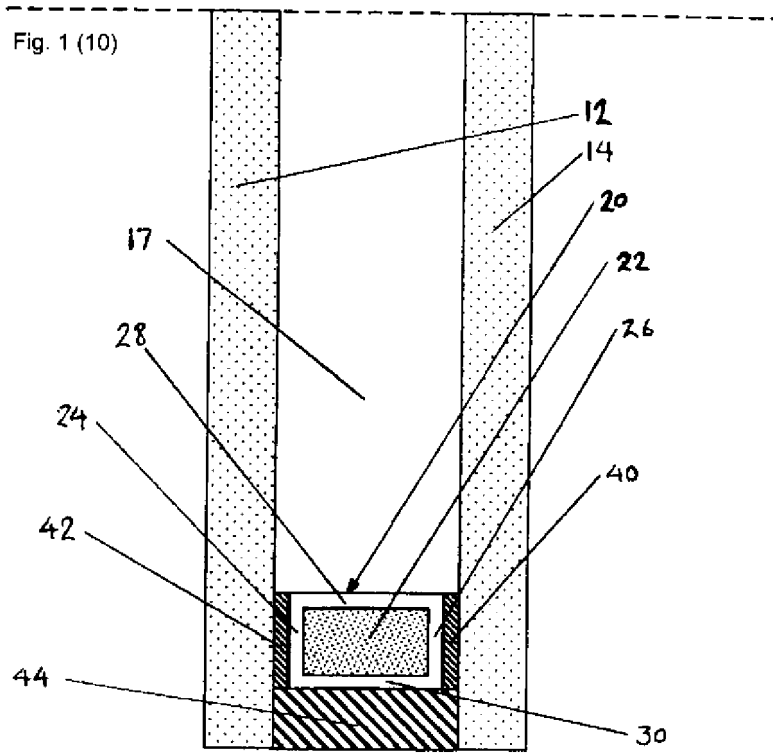

Fig. 2 (100)

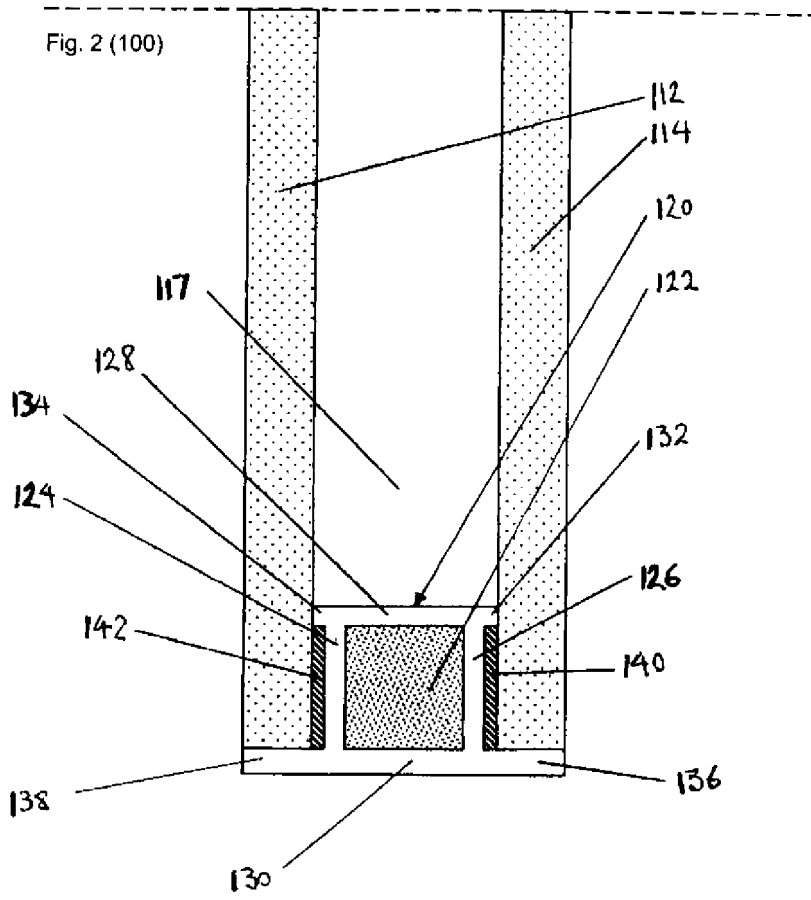

Fig. 3 (200)

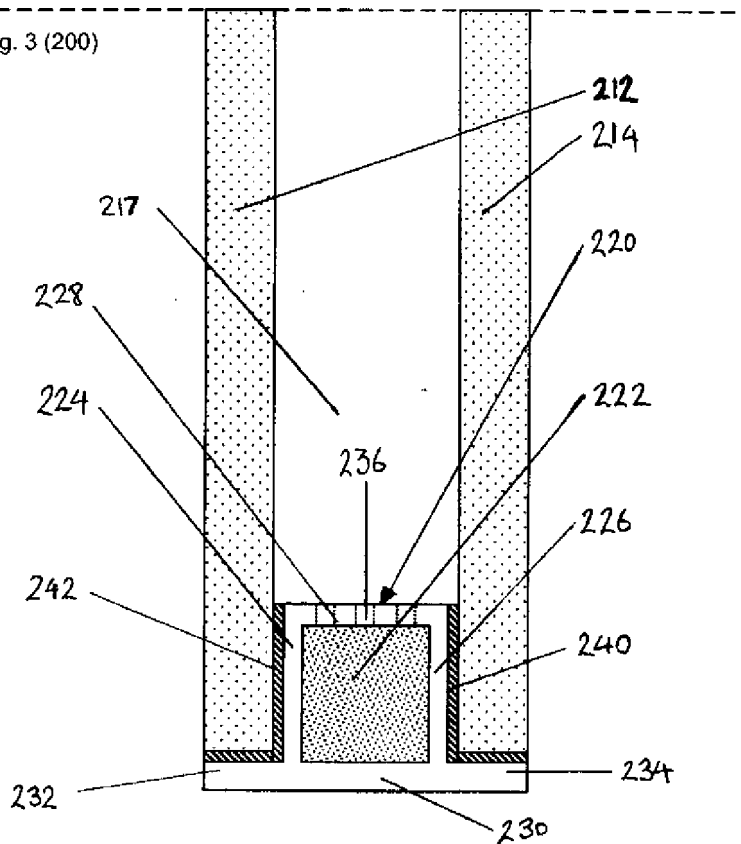
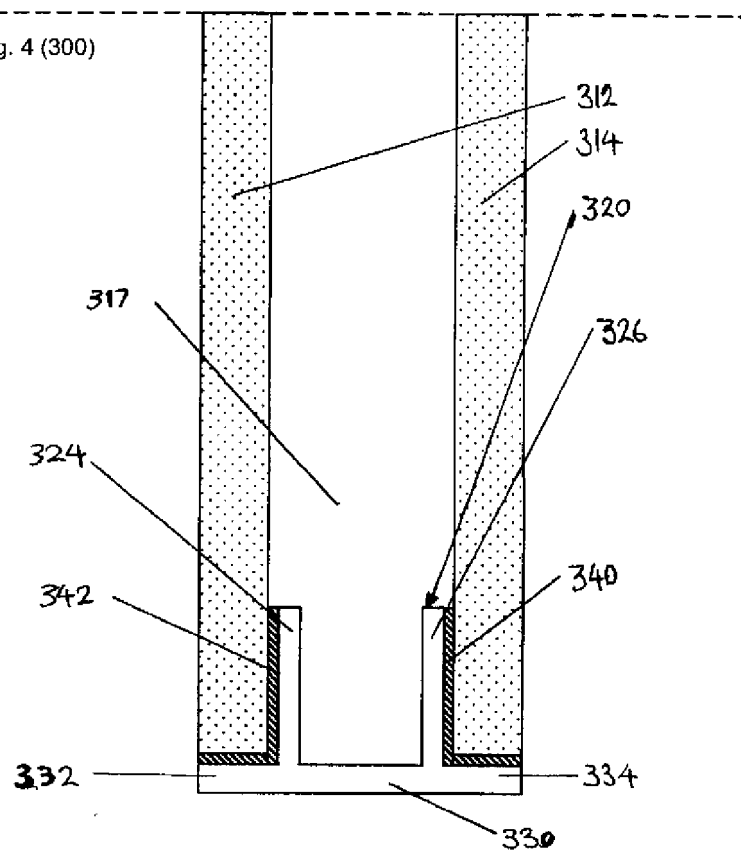

Fig. 4 (300)



## Spacer Bar to Improve Gas Barrier in Insulated Glass Unit

This invention relates to a spacer bar for use in constructing double glazed or insulated glass units, to such units so constructed and to a method for constructing an insulated glass unit comprising of at least two panes of glass separated by such a spacer, so as to form an effective gas barrier to gas, such as moisture, transfer into the internal cavity present in such units.

The Insulated Glass Units (IGUs) most widely used are made using a system where two separate and identical panes of glass are cut and sealed together. A spacer, pressed between the edges of the two panes is used to separate them, typically proximate the perimeter of the panes to create an internal gap, in the form of an internal cavity that is essential to the thermally insulating properties of IGUs. The spacer bar is sealed between the two panes of glass using a secondary sealant adhered to two faces of the bar. A primary hot melt sealant is used to seal the exterior edge of the glass and spacer. To further improve their insulating properties most IGU cavities are filled with a gas having a lower thermal conductivity than air, such as argon.

Because of its role of sealing a unit between the glass panes, and also bridging between the exterior edge and the internal cavity, the spacer is of great importance to the thermal efficiency of any IGU. There are two common technologies used in spacer design, standard metal spacers, normally made from aluminium or stainless steel and warm-edge spacers. As metal spacer material aluminium though light, strong and relatively inexpensive is a good thermal conductor and therefore can compromise the efficiency of the unit. Warm-edge spacers are becoming more prevalent though they can be less structurally sound, and are formed from polymers, such as in the form of polymeric composites or structural foams. Both standard and warm-edge systems use a very similar shaped spacer form. This is typically a hollow rectangular bar containing a desiccant to help draw out any remaining moisture within the internal cavity of the IGU at its time of creation.

With the currently accepted system for IGU production and spacer design, several issues can arise with the units. The permeability of the various sealants to moisture can lead to condensation or mould forming within the cavity, making the unit unsightly the water also acting as a thermal bridge. Of the various sealants that can be used in the systems, the least permeable sealants being the most complex and expensive to produce. Also, any pressure differential produced within the cavity can also lead to deflection of the glass panes and spacers, such as inwardly, making the window unsightly and also possibly compromising the

seal. The hot melt plastic used to seal the whole unit after the spacer has been adhered to the glass panes can, at high ambient temperatures, soften leading to pane-slippage, this can occur during transportation or installation particularly in warm climates. Movement of the panes can adversely affect the seals within a unit and its structural integrity.

Issues of permeability have been addressed in several spacer designs, as in US4171601. This provides an arrangement of adhesive combined with inwardly sloping faces of the spacer to form recesses for substantially continuous direct contact of frame members with panes to block passage of vapour and decrease permeability. Another approach to reducing gas escape from within the cavity is by creating a long thin diffusion path created by a U-shaped spacer as in EP01613990A1. An attempt to increase stability is apparent in GB2310880A as it discloses a rectangular cross-sectioned spacer bar with flanges extending from said cross section to form surfaces for engagement with the edges of the glass panel, helping to retain the panes in their correct position as the adhesive on their faces sets. A review of the various considerations can be found in Wolf, "Silicone Sealed Insulating Glass Units", a Dow Corning Publication and available from the internet.

While the above structures offer some advantages in certain areas, the intrinsic issues that are present within spacer design have not been tackled in a combined effort across all fronts. The present invention seeks to provide an IGU and method of producing that IGU with a spacer aiding its structural integrity, reducing or eliminating pane and spacer deflection and significantly improving the gas barrier provided by the spacer and the primary sealant.

The present invention in its various aspects is as set out in the appended claims.

The present invention provides, an elongate spacer bar for use in constructing an insulated glazed unit (IGU), the bar comprising: an elongate strip in the form of an external wall; further elongate strips in the form of side walls mounted perpendicular to the external wall; the elongate strips being of equal length; wherein: the side walls extend an equal distance away from the external wall; the side walls are parallel and separated by a lateral distance so as to form a cavity; the height of the side walls is less than a width of the external wall; the side walls are each mounted; at a first edge, perpendicular to one face of the external wall, and both on said one face of the external wall.

The mounting of the side walls on the external wall provides external ledges suitable for accommodating glazing panes used in the construction of an IGU separated by said lateral distance. This has the advantage that the spacer bar cannot inadvertently be pushed too far into the space between the glazing panes. In addition, it provides a periphery to the IGU that is made of the material of the spacer bar, which is typically a resilient and less fragile material than the glazing panes. The potential for breaking the IGU before installation, such as in a window frame, is therefore reduced. In particular, a significant advantage is that the external ledges provide, for a given intrusion of the spacer into the IGU internal cavity, a longer interface in which primary sealant may be applied so as to adhere the panes to the spacer. Whilst this has a benefit of improved strength, the bond being longer, this is not generally perceived to be an issue with such units, however, what is beneficial is that the pathway for moisture to permeate into the IGU internal cavity is longer and therefore either, for a given sealant, the cavity is better secured against moisture ingress (which gives rise to failure of the unit) or a sealants having higher moisture permeability per unit length may be used this giving increased flexibility in the materials used. A combination of the above features, the ledge giving location of the spacer around the periphery and the flexibility in use of materials means that hot melt sealant manufacture of IGU's is facilitated.

The present invention in its various aspects also provides that it is not necessary to use a secondary sealant. Secondary sealants are generally less effective as moisture barriers than primary sealants and the alternative construction of the present invention gives rise to a simpler construction, requiring less production steps to produce as well as using less material.

The elongate spacer bar of the present invention may comprise a further elongate strip being of equal length to the other elongate strips and of width equal to said lateral distance and mounted laterally to said side walls directly adjacent to a second edge of said side walls, said second edge being remote from said first edge, the further strip serving to form a

rectangular enclosure. The further elongate strip is preferably thinner than external wall so that the further strip may distort by a small amount so as to allow a degree of slope of the side walls, due to external pressure on the glass. This relieves localised pressure on the glass and reduces the chances of glass breakage at pressure points of the external corners of the enclosure.

In the above description and in this document a definition has been used of 'parallel'. Such as in the side walls (224, 226) extend an equal distance away from the external wall (230) the side walls (224, 226) are parallel. For the purposes of the present invention the term parallel means parallel or substantially parallel such that the angle of inclination of the surfaces to one another is from  $-3^\circ$  to  $3^\circ$  ( $0^\circ$  being perpendicular to the external wall (230, 330)). Preferably this is from  $0^\circ$  to  $3^\circ$ , positive angles being angles of taper away (and outward from one another) from the external wall. Such a taper, preferably in the range of  $1^\circ$  to  $3^\circ$ , enables the glass to distort inward without giving rise to a pressure point on the edge of the glass. Such a taper, preferably in the range of  $-1^\circ$  to  $-3^\circ$ , enables the glass to distort outward without giving rise to a pressure point at the edge of the glass, where crack propagation may start. However, the competing alternative, and preferable in its own right, perfectly parallel sides in which the thickness of the adhesive is therefore minimised for any given IGU joint using the spacer bar of the present invention.

The elongate spacer bar of the present invention may comprise a plurality of perforations so as to allow a flow of gas to and from said enclosure. The perforations are preferably present in the further elongate strip feature as previously described. Whilst the perforations have a conventional function of allowing gas transfer to from said enclosure they also facilitate a degree of distortion of the further elongate strip so that any vacuum or partial vacuum formed in the internal cavity, which brings the panes of glass together (bowing inward under external there pressure) and would otherwise give rise to a high stress point adjacent the second edge of the side. This is as considered above regarding the thickness of the wall in a combination of a reduced thickness and perforations is further preferable.

The elongate spacer bar of the present invention having an enclosure may contain a desiccant material in that enclosure. Not only does the present invention provide a spacer bar having a geometry for convenient location and improved sealing properties, it also enables a sealing material to be readily incorporated so that any moisture ingress into, or residual moisture on formation of, the internal cavity of the IGU can be removed.

The elongate spacer bar of the present invention may comprise one face of the external wall not being enclosed by said lateral distance, and thus representing two ledges, and sides of the said side walls perpendicular to said one face and also forming said ledges is coated

with an adhesive material for adhering glass. Whilst the ledges as mentioned are present in all embodiments of the spacer bar the present invention the location of an adhesive material on that ledge provides that the adhesive is correctly placed in the region required for use. This is particularly useful in situations where the adhesive is subsequently activated for adhesion to panes of glass, such as by means of heat.

For the purposes of the present invention an adhesive and a sealant are considered synonymous, this on the basis that suitable adhesives are adhesives which are good sealants against moisture ingress. Adhesives not being good sealants against moisture ingress are not adhesive as regards the present invention. A good sealant against moisture ingress has a water-vapour permeability in the form of a 3 mm sheet of 18g/m<sup>2</sup> per day at 20°C or less.

An insulated glazing unit comprising first and second equidistantly spaced panes of glass of the same dimensions wherein the perimeter of said panes is about that whole perimeter held apart by location on said ledges of an elongate spacer bar of the present invention or a plurality of such spacer bars and held in that position by means of said adhesive material, the perimeter enclosing a hermetically sealed internal cavity. The benefits of the geometry of the present invention, as mentioned herein, are realised on construction of an insulated glazing unit.

For the present invention the adhesive material used may be a hot melt adhesive. A particular problem, especially in countries of a hot climate is that IGU is repaired by hot melt adhesive can, over time in hot conditions, distort as the sealant can become plastic at high ambient temperature. The spacer bar of the present invention and IGU is formed with that spacer bar are much more thermally stable as the spacer bar has only one dimensional of movement available to it, out of the space between the panes of glass. Further, the increased length for adhesive material on the ledge of the present invention means that the strength of adhesion, not normally considered an issue with such products is improved this is because of the hot conditions it is not actually the strength of the adhesion but the yield stress of the joint (the adhesive being considered a viscous fluid for these purposes) is higher.

The spacer has a rectangular cross section with extending wings encompassing the edges of the panes to improve gas loss rates. The winged design also increases the length and adds a 90 degree change of direction to the path of diffusion for escaping argon, thus increasing its effective, but not actual, length in the plane of the glazing sheets. This diffusion path is kept from widening by a pressure differential present within the IGU. The pressure differential presses both glass and spacer more tightly together.

The present invention enables construction of an IGU also according to the present invention and this provides the benefits of:

Structural stability and ease and efficiency of assembly are also improved by the geometry of the spacer. The wings prevent pane slippage that can occur during the sealing process when being assembled or during transportation.

The increase in the interfacial depth of seal (the standard depth of spacer plus the thickness of glass) and its form encapsulating the edge of the unit also results in less sealant being required. This also provides the potential to use the spacer in conjunction with more highly permeable and inexpensive sealants.

The geometry and winged nature of the spacer also aids prevention of inward deflection of the spacer bar due to its fixed position to the exterior edge of glass panes.

The present invention avoids the use of a secondary sealant so as to simplify manufacture.

The present invention avoids the use of a secondary sealant so as to reduce material consumption.

By providing IGU edge protection the present invention produces the possibilities of breakage by edge impact of an IGU, such as during installation.

The present invention and background will now be illustrated by means of the attached drawings.

The following schematic drawings illustrate the prior art:

**Figure 1** (10) the basic construction of a conventional double-paned insulated glass unit (IGU)

**Figure 2** (100) shows known Prior Art GB2310880A

The following schematic drawings illustrate the present invention:

**Figure 3** (200) shows the present invention;

**Figure 4** (300) shows the variation of the present invention without the interior wall to the spacer bar and desiccant reservoir;

In the above drawings the following features are provided:

**Figure 1** (10) comprises the features:

12 Glass pane;

14 Glass pane;

17 Internal cavity;

20 Spacer bar;

22 Desiccant;

24 Side wall;

26 Side wall;

28 Interior wall;

30 External wall;

40 Primary adhesive;

42 Primary adhesive and

44 Secondary adhesive.

**Figure 2 (100)** comprises the features:

112 Glass pane;

114 Glass pane;

117 Internal cavity;

120 Spacer bar;

122 Desiccant reservoir;

124 Side wall;

126 Side wall;

128 Interior wall;

130 External wall;

132 Protrusion;

134 Protrusion ;

136 Flange;

138 Flange;

140 Primary adhesive and

142 Primary adhesive.

**Figure 3 (200)** comprises the features:

212 Glass pane;

214 Glass pane;

217 Internal cavity;

220 Spacer bar;

222 Desiccant reservoir;

224 Side wall;

226 Side wall;

228 Interior wall;

230 External wall;

232 Flange;

234 Flange;

236 Perforations;

240 Primary adhesive and

242 Primary adhesive.

**Figure 4** (300) comprises the features:

312 Glass pane;

314 Glass pane;

317 Internal cavity;

320 Spacer bar;

324 Side wall;

326 Side wall;

330 External wall;

332 Flange;

334 Flange;

340 Primary adhesive and

342 Primary adhesive.

The drawings will now be described with reference to the Figures:

**Figure 1** shows a known IGU illustrating the standard configuration for such a unit. Two panes of glass 12, 14 are separated by a spacer bar 20 adhered to the glass via a primary adhesive 40, 42. The internal cavity 17 is defined by the width of the spacer bar and the amount of adhesive sealant used. The cavities typically have a width ranging between 6mm-20mm and in some IGUs are filled with an inert gas such as argon or have an induced partial vacuum. The argon or partial vacuum both significantly increase the thermal efficiency of the IGU, although a vacuum can lead to issues of pane deflection due to any pressure differential created between the cavity and ambient pressure.

The type of glass used in the construction of IGUs varies and depends entirely on the client's requirements for the unit: toughened glass; laminated glass; low-E glass or acoustic glass can all be used, but most IGUs are made with two identical panes of glass 4mm thick. The present invention is considered suitable for use with glazing panes between 2 and 6 mm thick.

The spacer bar dictates the width of the internal cavity 17 and forms part of the seal which is vital to the integrity of the window. Spacers are traditionally made from aluminium due to it being lightweight, strong and reasonably inexpensive. However it can reduce the thermal efficiency of the IGU due to its high thermal conductivity. Spacers are conventionally substantially rectangular, hollow bars to allow for a desiccant reservoir 22 within the spacer. A representative desiccant is pure 3A molecular sieve or a 3A compound. The desiccant acts to draw out any moisture from within the internal cavity after sealing. There is therefore a concentration gradient between the moisture present in atmospheric air surrounding the IGU and that within the IGU. Moisture will therefore penetrate the internal cavity should the opportunity be available for this to occur. Further, ingress of moisture, such as during hot/cold heat cycling can lead to listing of the internal faces of the glass panes 12, 14 this rendering the IGU less thermally efficient, of lower clarity and aesthetically unappealing.

The primary adhesive 40, 42, which is normally a poly isobutyl sealant is applied to the spacer bar on each of its side walls 26, 24 and acts as the first seal that holds the spacer bar in place against the glass panes 12, 14 and plus retains the panes imposition, held at a uniform distance to one another. The adhesive is also critical as moisture barrier. This is because the glass of the glass panes 12, 14 and the metal of the spacer bar 20 are normally impermeable to moisture. Further, this arrangement of the panes prevents the metal of the spacer from being pressed directly against the glass of the panes during manufacture and transport. As will be appreciated, localised pressure on a pane of glass can lead to higher localised forces and breakage of the glass panes.

To supplement the primary adhesive, 90% of European IGUs employ a dual sealing process in conjunction with the spacer to create a moisture barrier and effectively seal the window. This involves the use of a secondary adhesive 44 as well as the primary adhesive. There are a number of types of secondary adhesives used to make this seal including polysulphide, polyurethane and silicone adhesives. The preferred form of adhesive is a hot melt adhesive; however, adhesives may also act by irreversible chemical action in a setting process. The two sealants 40, 42, 44 form an effective gas and moisture barrier between the atmosphere and the internal cavity.

The manufacture of high quality IGUs preferably takes place in an enclosed and conditioned environment. A relative humidity of less than 62% and an ambient temperature of less than 24°C help to reduce the risk of excess moisture being absorbed by the IGUs during production, as well as preventing dust from entering the units.

The first step of the production of a conventional IGU is to, where required, automatically fill the spacer bar with desiccant before being applied with the primary adhesive. This is preferably performed without the desiccant coming into contact with the ambient moisture, so conserving its moisture absorbing capabilities before going inside the IGU. Once the spacer has been applied with primary adhesive it is applied to one of the pre-washed glass panes, 12. If the processing line is not properly enclosed or the drying of the glass not complete then moisture could be present between the glass and primary adhesive. This could lead to an imperfect seal and later compromise the whole IGU. The risk of this is reduced by the next step which is to use a large glass press, i.e. one of at least the same or greater area than that presented by the large face of the IGU, to attach and adhere the second pane via the primary adhesive to the spacer. Due to the small amount of primary adhesive used in this process, with a low thermal mass, issues can arise if the primary adhesive is hot melt, because it will cool so rapidly against the glass that a perfectly aligned seal is difficult to attain.

Once the two panes of glass and spacer are removed from the glass press the secondary adhesive can be applied. The amount of secondary adhesive used is dictated by the gap between the spacer and the edge of the glass and is directly linked to the rigidity of the IGU. The depth of the secondary sealant combined with the depth of the spacer also define the length of the diffusion path into the internal cavity. Once the secondary sealant has set the IGU is ready for use.

**Figure 2 (100)** shows a known prior art IGU that has not been taken up by the industry, due to various intrinsic limitations, but is described due to its superficial similarity to the present invention, in particular, it avoids the use of a secondary sealant. As will be evident from viewing Figure 2 the basic layout of the IGU is similar to that mentioned above regarding a conventional design as shown in Figure 1.

The design employs a spacer 120 with a geometry produced to remove the need for a secondary adhesive by employing flanges 138, 136, which are extruded from the external wall 130 of the spacer, to stabilise the unit. The spacer also incorporates protrusions 132, 134 from the interior wall 128 of the spacer.

The IGU in Figure 2 relies upon a small amount of primary adhesive 140, 142 to maintain the seal between spacer and the glass panes 112, 114 and hold the entire IGU together as a rigid unit. The small amount of adhesive leads to issues with the sealing process as the low thermal mass leads to hot melt adhesive cooling very rapidly against the glass which makes a properly aligned seal difficult to attain.

The pressing process involved in the construction of IGUs would help to improve the seal however new issues also arise at this stage when using the spacer outlined in figure 2. The seal of the primary adhesive which is even more vital in this design due to the lack of secondary adhesive is aided by the even pressing against the spacer, yet due to the spacer's design the glass can only be pressed into the adhesive to the depth of the protrusions 132, 134, where the glass 112, 114, meets the spacer. This reduces the chances of attaining a proper seal with the vital primary adhesive. The pressing can create pressure points where the metal of the protrusions meets directly with the panes of the glass, this can lead to cracking of the panes of glass.

The use of small quantity of primary adhesive applied only on the side walls of the spacer and lack of any extra primary adhesive or a secondary adhesive also significantly reduces the effectiveness of the moisture barrier formed by the spacer as it shortens the diffusion path for moisture to enter into the internal cavity 117.

**Figure 3 (200)** shows an IGU of the present invention where some similarities to conventional spacer design are apparent. The spacer bar 220 is substantially rectangular and constructed from aluminium to reduce production costs and produce a finished result that is light, strong and deformation resistant. The hollow nature of the spacer allows for a

desiccant reservoir 222. The desiccant draws out any moisture from within the internal cavity 217 through the perforations 236 in the interior wall 228.

The innovation of the present invention, in its various forms, lies in the spacer bar's geometry, the design uses the spacer form to improve the gas barrier and seal that are vital to an IGU for a given sealant material. The present invention is designed so that only a small amount of primary adhesive 240, 242, and no secondary adhesive is required to produce a proper seal and gas barrier between the atmosphere and the internal cavity 217.

The spacer has flanges 232, 234 extruding from the external wall 230. The flanges extend over the edges of the glass panes 212, 214 and by doing so help to brace the window, aiding the IGUs structural integrity. The spacer design, by extending around the edges of the panes via the flanges also avoids pane slippages from occurring. In this way it aids assembly but also helps to prevent issues after production as pane slippages can occur during transportation or if the IGU is subject to high temperatures.

The primary adhesive 240, 242 is applied to the spacer on both the side walls 224, 226 and the inner faces of the flanges 232, 234, which increases the interfacial depth of the seal. The inclusion of a right angle in the diffusion path also makes it more tortuous and resistant to moisture permeation.

By incorporating stabilising flanges and removing any secondary adhesive the invention also aids efficiency of assembly; fewer processes are required to produce an IGU using this spacer as no secondary adhesive application and setting is required to complete a dual seal system. The spacer does not compromise the effectiveness of the pressing process as in the known prior art illustrated in fig. 2. The nature of the design allows for equal distribution of force across the adhesive while pressing without creating pressure points. The present invention also avoids the issues that can arise when areas of glass meet exposed metal with no adhesive to act as a buffer.

The natural pressure differential created within an IGU can lead to inward deflection of a spacer however the flanges of the invention reduce the risk of this occurring. The pressure differential actually aids the design as it helps to press the spacer more tightly against the glass via the primary adhesive 240, 242. The sealant being adhered to two sides of each pane provides shear and tensile strength which also assist the IGU's seal integrity.

The advantages to seal integrity created by the geometry, paired with the present invention's lack of need for a secondary adhesive means that only small amounts of adhesive are required to create a strong and effective seal and gas barrier. This also provides the

opportunity for the spacer to be used in conjunction with more highly permeable and therefore less expensive adhesives without any loss of performance.

**Figure 4** (300) shows a variation on the present invention with a slightly different geometry to the spacer. In a situation where the internal cavity of an IGU is present as a vacuum or partial vacuum then a desiccant may not be necessary. This embodiment of the invention which has no desiccant reservoir could be utilised in the event that the IGU has an induced partial vacuum within the internal cavity rather than being filled with a gas with a low thermal conductivity, such as the inert gas argon.

If there is a situation where there is a large pressure differential between the atmosphere and internal cavity due to the induced vacuum then there could be issues with a spacer design such as the one illustrated in fig 3. The pressure differential can result in deflection of the glass panes 312,314 inwards. If this occurred when using the spacer 220 rather than 320 then it could lead to an excessive pressure being generated at the corners where the side walls 224, 226 meet the interior wall 228. This could give rise to both weakening and destabilising of the joint as the glass is pried away from the spacer, or even cracking of the panes 212, 214 as the point pressure builds. To avoid this, the spacer 320 is provided, with this design the inward deflection and bowing of the glass panes 312, 314 is accommodated by the distortion of the angle between 332 and 324 from a right angle to an obtuse angle. This variation of the present invention therefore provides the same long diffusion path through the primary adhesive 340 and 342, providing an effective moisture barrier in a situation where a partial vacuum is utilised within the internal cavity 317.

In the present invention the sealant may be first applied to the spacer bar before the panes of glass are applied to the sealant. The lower thermal mass of the spacer bar provides a longer open time for the sealant, particularly when the sealant is a hot melt adhesive.

In the present invention spacer bar or bars preferably do not directly physically contact the panes of glass. This reduces the possibilities for localised pressure points and cracking of glass, particularly where the spacer bar is a metal, such as aluminium.

In the present invention the spacer bar or bars may be constructed from aluminium but may be preferably constructed from a plastics material, such as polyvinyl chloride or a poly alkylene.

All measurements in this document are taken at 20°C and 1 atm pressure unless otherwise stated. A vacuum means 300mmHg or less.

## Claims,

1. An elongate spacer bar (220, 320) for use in constructing an insulated glazed unit (IGU), the bar comprising:

an elongate strip in the form of an external wall (230);

further elongate strips in the form of side walls (224, 226) mounted perpendicular to the external wall (230);

the elongate strips (224, 226, 230) being of equal length;

wherein:

the side walls (224, 226) extend an equal distance away from the external wall (230);

the side walls (224, 226) are parallel and separated by a lateral distance so as to form a cavity (322);

the height of the side walls (224, 226) is less than a width of the external wall;

the side walls (224, 226) are each mounted at a first edge perpendicular to, and on one face of the external wall (230),

the mounting of the side walls (224, 226) on the external wall (230) provides external ledges suitable for accommodating the full thickness of a glazing pane for use in the construction of an IGU separated by said lateral distance.

2. The elongate spacer bar (220) of claim 1 comprising a further elongate strip (236) being of equal length to the other elongate strips (224, 226, 230) and of width equal to said lateral distance and mounted laterally to said side walls (224, 226) directly adjacent to a second edge of said side walls, said second edge being remote from said first edge, the further strip (236) serving to form a rectangular enclosure (222).

3. The elongate spacer bar (220) of claim 2 warring said further elongate strip (236) comprises a plurality of perforations so as to allow a flow of gas to and from said enclosure (222).

4. The elongate spacer bar of claim 2 or claim 3 wherein said enclosure (222) contains a desiccant material.

5. The elongate spacer bar of any preceding claim wherein the one face of the external wall (230, 330) not being enclosed by said lateral distance, and thus representing two

ledges, and sides of the said side walls (224, 226) perpendicular to said one face and also forming said ledges is coated with an adhesive material for adhering glass (312, 314).

6. An insulated glazing unit comprising first (212, 312) and second (214, 314) equidistantly spaced panes of glass of the same dimensions wherein the perimeter of said panes is, about their whole perimeter, held apart by location on said ledges of an elongate spacer bar or bars of any preceding claim and held in that position by means of said adhesive material, the perimeter enclosing a hermetically sealed internal cavity (217, 317) .

7. The insulated glazing unit of claim 6 wherein the adhesive material is a hot melt adhesive.

8. The insulated glazing unit of claims 6 or 7 wherein the spacer bar or bars do not directly physically contact the panes of glass.

9. The insulated glazing unit of any of claims 6 to 8 wherein the spacer bar is constructed from aluminium.

10. A method of manufacturing an insulated glazing unit, the method comprising:  
providing an elongate spacer bar as provided in any of claims 1 to 5;  
providing two panes of glass of the same dimensions;  
providing a sealant for adhering the panes of glass to the spacer bar;  
adhering the panes of glass about their perimeter to the spacer bar, being in one or more pieces, the spacer bar being placed around the whole perimeter of the panes of glass.

11. The method of claim 8 wherein the sealant is a hot melt adhesive.

12. The method of claim 8 or 9 wherein the sealant is first applied to the spacer bar before the panes of glass are applied to the sealant.

13. The method of any of claims 10 to 12 wherein the spacer bar or bars do not directly physically contact the panes of glass.

14. The method of any of claims 10 to 13 wherein the spacer bar is constructed from aluminium.



**Application No:** GB1419226.4

**Examiner:** Mr Matthew Dance

**Claims searched:** 1-14

**Date of search:** 18 March 2015

**Patents Act 1977: Search Report under Section 17**

**Documents considered to be relevant:**

Category	Relevant to claims	Identity of document and passage or figure of particular relevance
X	1-14	GB2070119 A (SAAR GUMMIWERK GMBH) See especially Figure 3 and Abstract, showing panes (12, 14) which are bonded by adhesive to a spacer bar with ledges (28, 30), side walls (16a), cavity 26 for desiccant material and perforation 44
X	1-14	NL7603812 A (SIV SOC ITALIANA VETRO) See Abstract and Figure 1 showing metal spacer bar 1 having ledges (3, 3') and perforation 2
X	1-14	GB1159001 A (BARNES) See Figures 1 & 6, and page 1, lines 62-77, disclosing a spacer bar with cavity "a" for desiccant material and perforations "a2"
X	1-14	FR1079389 A (BELGE) See Figures, showing a spacer bar with ledges and a perforated cavity containing desiccant material, wherein the side walls and ledges are covered in an adhesive (16, 17)
X	1-14	EP0113209 A (OMNIGLASS) See Figure 7
X	1-14	WO 2004/106690 A (FULLER) See at least Figure 1 showing panes of glass (32, 36), side walls (16, 22), sealant 34 and desiccant material 30
X	1-14	DE2620964 A (HASSELBACHER) See Figures 1 & 2, showing aluminium spacer bar with ledges, to which sealant is applied (14, 28) to attach a pane of glass

**Categories:**

X	Document indicating lack of novelty or inventive step	A	Document indicating technological background and/or state of the art.
Y	Document indicating lack of inventive step if combined with one or more other documents of same category.	P	Document published on or after the declared priority date but before the filing date of this invention.
&	Member of the same patent family	E	Patent document published on or after, but with priority date earlier than, the filing date of this application.

**Field of Search:**

Search of GB, EP, WO & US patent documents classified in the following areas of the UKC<sup>X</sup> :

--



Worldwide search of patent documents classified in the following areas of the IPC

E06B

The following online and other databases have been used in the preparation of this search report

WPI, EPODOC

**International Classification:**

<b>Subclass</b>	<b>Subgroup</b>	<b>Valid From</b>
E06B	0003/663	01/01/2006