

(19) **DANMARK**

(10) **DK/EP 3205778 T3**



Patent- og
Varemærkestyrelsen

(12) **Oversættelse af
europæisk patentskrift**

-
- (51) Int.Cl.: **E 02 F 3/92 (2006.01)**
- (45) Oversættelsen bekendtgjort den: **2019-03-18**
- (80) Dato for Den Europæiske Patentmyndigheds bekendtgørelse om meddelelse af patentet: **2018-12-12**
- (86) Europæisk ansøgning nr.: **17154845.6**
- (86) Europæisk indleveringsdag: **2017-02-06**
- (87) Den europæiske ansøgnings publiceringsdag: **2017-08-16**
- (30) Prioritet: **2016-02-05 BE 201605092**
- (84) Designerede stater: **AL AT BE BG CH CY CZ DE DK EE ES FI FR GB GR HR HU IE IS IT LI LT LU LV MC MK MT NL NO PL PT RO RS SE SI SK SM TR**
- (73) Patenthaver: **Baggerwerken Decloedt en Zoon N.V., Slijkensesteenweg 2, 8400 Oostende, Belgien**
- (72) Opfinder: **TACK, Bruno, Vrijestraat 10, 9960 Assenede, Belgien**
- (74) Fuldmægtig i Danmark: **NORDIC PATENT SERVICE A/S, Bredgade 30, 1260 København K, Danmark**
- (54) Benævnelse: **GRAVEHOVED OG TILHØRENDE FREMGANGSMÅDE TIL AT UDARBEJDE EN RENDE I EN HAVBUND**
- (56) Fremdragne publikationer:
WO-A1-2012/104314
WO-A1-2013/174932
GB-A-2 097 839

DESCRIPTION

TECHNICAL FIELD OF THE INVENTION

[0001] The invention relates to a dredging head which is configured to form a trench in an underwater bottom. The invention likewise relates to a dredging device comprising the dredging head, and a method for forming a trench in an underwater bottom while making use of the dredging head.

BACKGROUND OF THE INVENTION

[0002] The forming of a trench in an underwater bottom is for instance usual when arranging cables, conduits or other elongate objects in an underwater bottom. A known device for forming a trench in an underwater bottom is described for instance in WO 01/92650 A1. Described herein is a remotely operated vehicle, or ROV, which in use travels over an underwater bottom. A series of water jets arranged on an outward foldable arm fluidize the underwater bottom, whereby a trench is formed in which a cable or other elongate object can then be arranged. The known trench-forming vehicle can operate reasonably accurately, although production (or forward progress) is relatively slow, among other reasons because the vehicle moves over the underwater bottom and the supplied power is relatively low. Forming a trench in a sandy bottom with the known vehicle is in addition problematic. A trench formed in a sandy bottom has a gentle degree of natural slope, for instance about 1/3 (1 m in vertical direction and 3 m in horizontal direction). In order to form a trench of for instance 2 m deep with a bottom width of 0.5 m in sand the trench has to be $0.5 + 2 \cdot 3 \cdot 2 = 12.5$ m wide on the upper side. Required for this purpose is a vehicle with a width which far exceeds 15 m (making allowance for the caterpillar tracks and a safe distance to the formed trench). Such a vehicle is not easy to make and operate.

[0003] Further also applied are ploughing devices which are pulled on a tow cable behind a vessel over an underwater bottom and form a V-shaped trench therein. Such devices are lacking in accuracy since the plough is generally a great distance away on the underwater bottom and route corrections therefore take effect slowly. Great power is in addition generally necessary because the plough must push the bottom material laterally and upward. A plough must also have considerable dimensions in the case of a sandy bottom with a gentle degree of natural slope. The plough cannot adapt sufficiently well in the case of varying types of ground. A device and method according to the prior art are disclosed in WO2013/174932A1.

[0004] Although the known devices are able to form a trench in an underwater bottom, they generally lack the necessary accuracy. For the purpose of laying cables and conduits in an underwater bottom it may well be important to be able to form a trench with a route which does not differ much from an intended optimal route. If there is indeed a difference, this can result in

great losses. Because during forming of the trench bottom material is removed which must be subsequently redeposited into the trench - in any case when burying cables, conduits and the like - it may also be important to not remove too much bottom material during forming of the trench, since this reduces efficiency. It should finally also be noted that the above stated inaccuracy is a particular problem in the case of underwater bottoms with a relatively high cohesion, such as bottoms comprising clay.

SUMMARY OF THE INVENTION

[0005] The present invention has for its object, among others, to provide a dredging head for forming a trench in an underwater bottom with an improved accuracy and efficiency compared to the known device, particularly also in bottoms comprising clay.

The dredging head according to the invention comprises for this purpose a dredging head according to claim 1. The dredging head for forming a trench in an underwater bottom comprises a connecting part for connecting to a suction-blow conduit of a dredging vessel to be moved in a dragging direction, and a visor for pivoting around a horizontal axis running transversely of the dragging direction with an opening facing toward the bottom for taking up bottom material dislodged by a lower edge of the visor, wherein the dredging head further comprises a discharge device for the dislodged bottom material, which discharge device comprises an inlet for the bottom material connecting to the opening of the visor and at least one outlet which is configured such that during movement in the dragging direction the bottom material can be discharged to at least one lateral side of the formed trench.

[0006] A dredging head according to the invention allows a trench to be formed in efficient manner in an underwater bottom. The invention provides for this purpose a method wherein the invented dredging head is connected to a suction-blow conduit of a dredging vessel, a dredge pump of the dredging vessel carries water through the suction-blow conduit in the direction of the dredging head and the dredging head is moved over the underwater bottom in a dragging direction along an intended route of the trench, wherein an opening of the visor of the dredging head facing toward the bottom takes up bottom material dislodged by a lower edge of the visor and, via the inlet of the discharge device connecting to the opening of the visor, discharges this material to the at least one outlet of the discharge device which is configured such that during movement in the dragging direction the bottom material is discharged to at least one lateral side of the formed trench. Discharge of the dislodged bottom material to one or both lateral sides is realized in that the suction-blow conduit of the dredging vessel blows water through the dredging head, wherein the dislodged bottom material is entrained in the water flow and via the discharge device comes to lie adjacently of the formed trench.

[0007] The dredging head according to the invention is accurate, among other reasons because steering adjustment can be made relatively quickly and, if desired, it can be (temporarily) removed from the bottom. Relatively little power is moreover required, among other reasons because the dislodged bottom material is immediately carried away from the

dredging head. This reduces the ground resistance. The distance over which the dislodged bottom material is blown away can also be controlled by regulating the flow rate of the water flow through the suction-blow conduit, for instance from the bridge of the vessel. This makes the dredging head particularly suitable for use in varying types of ground because the dredging head itself need not be adapted. This makes forming of a trench much more flexible.

[0008] Because the bottom material removed by the trench forming is deposited on preferably both sides along the route, and so in the immediate vicinity of the formed trench, in an embodiment of the method according to the invention the formed trench can be filled in efficient manner by moving the bottom material discharged and heaped on at least one lateral side into the trench with an apparatus suitable for the purpose, such as a bulldozer. For the purpose of laying cables, conduits or other elongate objects, in another embodiment of the method the formed trench is provided with the object prior to filling thereof.

[0009] The dredging head is connected to a suction-blow conduit of a dredging vessel, for instance a trailing suction hopper dredger. The dredging head is provided in known manner with a visor which can be rotated between a lowered and a raised position around an axis running transversely of a dragging direction. The visor has a suction opening facing toward the bottom for suctioning up bottom material dislodged by a lower edge of the visor. During dredging of an underwater bottom the dredging head connected to the suction-blow conduit is lowered underwater and dragged in the lowered position in a dragging direction of the trailing suction hopper dredger over the bottom for dredging, wherein bottom material is dislodged. The dislodged bottom material is generally suctioned away with a quantity of water to a bin of the dredging vessel by the suction-blow conduit connected to a dredge pump. However, with proper use of the dredging head according to the invention the flow through the suction-blow conduit is switched from a suctioning position to a blowing position, wherein water is pumped through the suction-blow conduit in the direction of the dredging head. This can for instance take place with hydraulic controls in the suction-blow conduit.

[0010] An embodiment of the invented dredging head has the feature that the discharge device comprises two outlets which are configured such that during movement in the dragging direction the bottom material can be discharged on both lateral sides of the formed trench. The bottom material deposited on one or both lateral sides is preferably situated in the immediate vicinity of the formed trench. This is understood to mean a distance adjacently of the trench of a maximum of 20 times the trench width, more preferably a maximum of 15 times the trench width, still more preferably a maximum of 10 times the trench width and most preferably a maximum of 5 times the trench width.

[0011] Another embodiment according to the invention provides a dredging head wherein the discharge device is connected for pivoting around a horizontal axis running transversely of the dragging direction to the connecting part or the suction-blow conduit. This embodiment allows adjustment of the angular position of the discharge device, in particular the angular position of the at least one outlet of the discharge device, relative to the horizontal plane. It hereby becomes possible to determine the distance adjacently of the trench at which on average the

excavated bottom material comes to lie during forming of the trench. It is also possible to connect the discharge device for pivoting around a horizontal axis running parallel to the dragging direction to the connecting part or the suction-blow conduit.

[0012] In a practical embodiment of the invented dredging head the discharge device is attached, preferably rigidly, to the visor or forms a part of the visor. The angular position of the discharge device can hereby be adjusted together with the angular position of the visor.

[0013] A further embodiment of the invention provides a dredging head wherein at least one of the connecting part, the visor and the discharge device is connected for pivoting around a vertical axis to the suction-blow conduit or the connecting part. Such a connection allows at least one of the connecting part, the visor and the discharge device to rotate in a horizontal plane during forming of the trench. This enhances the accuracy of the route being followed. Under the influence of current and waves a dredging vessel will generally follow a route which varies to some extent from a desired route. Because the dredging head is connected via the suction-blow conduit to the dredging vessel, the route followed by the dredging head depends on the route of the dredging vessel. The present embodiment allows, within limits, the route of the dredging head to be made independent of the route of the dredging vessel.

[0014] An embodiment which is useful in this respect is obtained with a dredging head wherein the at least one pivoting connection is controlled by an actuator. In another embodiment the connecting part is connected for pivoting around a vertical axis to the suction-blow conduit.

[0015] The actuators with which at least one of the connecting part, the visor and the discharge device can be pivoted around a vertical and/or a horizontal axis preferably comprise hydraulic cylinders, piston rods of which engage on a wall part of the respective component for controlling, and the cylinder housing of which engages on a fixed wall part, for instance of the suction-blow conduit. The wall part can be moved by extending or, conversely, retracting the movable cylinder rod. The connecting part for instance can thus be rotated in a horizontal plane by retracting a piston rod arranged on port side on an upper wall part of the connecting part (as seen in upstream direction) so that the dredging head is moved more to port side. It is for instance also possible to carry the discharge device to a raised position by retracting a piston rod arranged on an upper wall part of the discharge device, or to move it in the direction of a lowered position by extending the piston rod.

[0016] The route followed by the dredging head can further be set more precisely by providing a dredging head in an embodiment which further comprises a steering fin which extends in the dragging direction and which is configured to penetrate into the underwater bottom. Such a steering fin produces a reaction force in the underwater bottom with which the dredging head can be steered more effectively in a desired direction.

[0017] A practical embodiment of the dredging head is characterized in that an underside of the connecting part comprises one or more steering fins. Such steering fins can for instance comprise a number of plates welded to the underside of the connecting part, preferably parallel

to each other.

[0018] Yet another embodiment according to the invention provides a dredging head wherein the lower edge of the visor comprises at least two series of cutting tools for penetrating into the bottom, wherein each series extends along a line transversely of the dragging direction, and wherein the cutting tools of a first series penetrate less deeply into the bottom than the cutting tools of a second series located downstream relative to the first series. Such a setup allows a relatively deep trench to be formed in the underwater bottom in one pass of the dredging head, wherein the first series of cutting tools forms a trench to a first depth, which first depth is further deepened to a greater second depth with the second series of cutting tools. The geometry of the cutting tools can for instance be adapted here to the ground condition. The depth to which the first and second series of cutting tools can be inserted can be selected within broad limits. Suitable excavating depths for each series depend on, among other factors, the ground condition and can amount for instance to between 10-80 cm, more preferably to between 20-70 cm and most preferably to between 30-50 cm.

[0019] The accuracy with which the dredging head can follow a desired route can be further improved by providing an embodiment wherein the connecting part comprises two lateral walls and the walls are provided with laterally extending blades. These blades preferably have a concave front surface, wherein the front surface faces in an upstream direction during forming of the trench. A side edge of the blades preferably runs obliquely upward, this such that the blades widen in upward direction. A trench is hereby obtained which widens a little from the bottom upwards. Such an upward widening trench section allows the suction-blow conduit to be placed at an angle in the trench, whereby the dredging head can better follow a desired route.

[0020] The discharge device can in principle take any form as long as it comprises an inlet for the bottom material connecting to the opening of the visor, and one or more outlets. A suitable embodiment comprises a box-like holder body, an end surface of which connects to the opening of the visor. On another side the holder body comprises one or more spout-like outlets which are oriented in lateral direction relative to the formed trench (or a vertical central plane of the dredging head).

[0021] The dredging head is particularly suitable for forming a relatively narrow trench. An embodiment of the dredging head is characterized for this purpose in that it has a width transversely of the dragging direction of a maximum of 3 m, more preferably a maximum of 2.5 m, still more preferably a maximum of 2 m and most preferably a maximum of 1 m.

[0022] The invention likewise relates to a dredging device for forming a trench in an underwater bottom, comprising a dredging vessel configured for movement in a dragging direction and a dredging head according to the invention connected to a suction-blow conduit of the dredging vessel.

[0023] An embodiment of the dredging device comprises control means for controlling the

dredging head, in particular for controlling the position of the dredging head. The dredging head or components of the dredging head, such as the visor, the discharge device and/or the connecting part, are for this purpose preferably connected for pivoting around a horizontal and/or vertical axis running transversely of the dragging direction to a fixed component, for instance the suction-blow conduit. The pivoting connections are controlled in embodiments by an actuator, preferably a hydraulic cylinder, wherein the control means are configured to control the actuators. Such control means are per se known and are for instance used in the known trailing suction hopper dredger to adjust the angular position of the visor relative to the horizontal plane.

[0024] Provided in yet another aspect of the invention is a method for forming a trench in an underwater bottom with the dredging device. The dredging head is connected here to the suction-blow conduit of the dredging vessel, a dredge pump of the dredging vessel carries water through the suction-blow conduit in the direction of the dredging head and the dredging head is moved over the underwater bottom in a dragging direction along an intended route of the trench. An opening of the visor of the dredging head facing toward the bottom takes up bottom material dislodged by a lower edge of the visor and, via the inlet of the discharge device connecting to the opening of the visor, discharges this material to the at least one outlet of the discharge device which is configured such that during movement in the dragging direction the bottom material is discharged to at least one lateral side of the formed trench.

[0025] The method according to the invention is particularly suitable for forming a trench in a cohesive underwater bottom, preferably an underwater bottom comprising clay.

[0026] It is expressly stated that the embodiments of the invention described in this patent application can be combined in any possible combination of these embodiments, and that each embodiment can individually form the subject-matter of a divisional patent application.

BRIEF DESCRIPTION OF THE FIGURES

[0027] The invention will now be further elucidated on the basis of the following figures and description of a preferred embodiment, without the invention otherwise being limited thereto. In the figures:

Figure 1 is a schematic side view of a dredging device according to an embodiment of the invention;

Figures 2A-2C are schematic rear views of a dredging device according to an embodiment of the invention;

Figure 3 is a schematic perspective top view of a dredging head according to an embodiment of the invention;

Figure 4 is a schematic perspective side view of the dredging head shown in figure 3;

Figure 5 is a schematic perspective side view of the dredging head shown in figure 3; and

Figure 6 is finally a schematic rear of the dredging head shown in figure 3 during the forming of a trench in an underwater bottom.

DESCRIPTION OF EXEMPLARY EMBODIMENTS

[0028] Figure 1 shows a dredging vessel 1 which is provided with a motor, not shown in the drawing, for driving a propeller 2 via a propeller shaft for the purpose of propelling dredging vessel 1 in a dragging direction 7. Also present are devices, not shown in the drawings, for steering dredging vessel 1, such as a rudder and transversely placed propellers for facilitating manoeuvring.

[0029] A dredge pump, not shown in the drawings, is arranged in dredging vessel 1. Arranged against a side wall of the dredging vessel is a suction-blow conduit 3, one end of which is connected to the dredge pump. In the present embodiment the suction-blow conduit 3 comprises two members 3a and 3b which are connected to each other by means of a coupling 3c allowing some relative angular displacement. The connection between upper member 3a of suction-blow conduit 3 and the vessel also allows angular displacement in the vertical plane and about a substantially horizontal axis 3d. For support of the movable end of upper member 3a of suction-blow conduit 3 this member is connected to a cable 4a, the other end of which is connected to a winch 5a. For support of the movable end of lower member 3b of suction-blow conduit 3 this member is likewise connected to a cable 4b, the other end of which is connected to a winch 5b. It is thus possible using winches 5a, 5b to vary the height of suction-blow conduit 3. It will be apparent that, also subject to the depth of the underwater bottom, the number of members of suction-blow conduit 3 can be increased or decreased, with a corresponding adjustment of the number of cables 4 and winches 5. A dredging head 6 according to the invention is arranged on the free end of second member 3b of suction-blow conduit 3.

[0030] Referring to figure 3, an embodiment of dredging head 6 is shown. Dredging head 6 comprises a connecting part 8 which is connectable to suction-blow conduit 3 and which in the shown embodiment comprises a fixed connecting part 8a and a movable connecting part 8b connected for pivoting around vertical shaft 9 to fixed connecting part 8a. Fixed connecting part 8a can be attached fixedly to suction-blow conduit 3 with flange 10. Dredging head 6 further comprises a visor 12 which is rotatable relative to connecting part 8 around a shaft 11 running transversely of dragging direction 7 and which has an opening 13 facing toward the bottom for taking up dislodged bottom material 14. In the shown embodiment a lower edge of visor 12 comprises two series of cutting devices (15a, 15b) for penetrating into the bottom. Cutting devices (15a, 15b) are per se known and can comprise any type of tooth. Each series of cutting devices (15a, 15b) extends along a line transversely of dragging direction 7. Cutting devices 15a of the first series moreover penetrate less deeply into the bottom than cutting

devices 15b of the second series of cutting devices 15b lying upstream relative to the first series. The cutting devices can for instance be mounted in usual manner on a toothed beam running transversely of dragging direction 7.

[0031] Dredging head 6 is further provided with a discharge device 16 for discharging the dislodged bottom material 14 laterally of the formed trench. In shown embodiment discharge device 16 comprises a box-like body comprising two side walls (16a, 16b), an upper wall 16c and a lower wall 16d. Discharge device 16 connects with a first end surface 17a to an opening (not shown) in a rear wall of visor 12. First end surface 17a thus forms an inlet for dislodged bottom material coming from visor opening 13. Discharge device 16 further comprises a second end surface 17b which is located opposite first end surface 17a and which connects to two spout-like parts (18a, 18b). Each part (18a, 18b) is provided with an outlet (19a, 19b) along which dislodged bottom material can escape. Spout-like parts (18a, 18b) form a throughfeed channel for the bottom material and both extend outward from a vertical plane of symmetry 20 of dredging head 6 at an oblique angle 21 to a horizontal plane 22, see for instance figure 4. As is made clear in figure 6, outlets (19a, 19b) are configured such that during the movement of dredging head 6 in dragging direction 7 the bottom material 14 is discharged to both lateral sides of the formed trench 23 and deposited there as according to arrows (24a, 24b). In order to form a relatively narrow trench 23 the shown dredging head 6 can have a width of a maximum of 2 m transversely of the dragging direction 7.

[0032] In the shown embodiment of dredging head 6 the discharge device 16 is attached fixedly to visor 12 via end surface 17a, for instance by means of a welded connection. Discharge device 16 can thus pivot, together with visor 12, around the horizontal shaft 11 running transversely of dragging direction 7. The angular position of visor 12 and discharge device 16 relative to the horizontal plane 22 can be adjusted by an actuator in the form of a hydraulic cylinder 25 which can be controlled from dredging vessel 1 with appropriate and per se known control means (not shown).

[0033] In the shown embodiment movable connecting part 8b is connected for pivoting around a vertical shaft 9 to fixed connecting part 8a, which is in turn fixedly connected to lower member 3b of suction-blow conduit 3. The angular position of movable connecting part 8a (and so also of visor 12 and discharge device 16) relative to the vertical central plane 20 can be adjusted by a second actuator in the form of a hydraulic cylinder 26 which engages on fixed connecting part 8a at a distance from the vertical central plane 20 and can be controlled from dredging vessel 1 with appropriate and per se known control means (not shown). Rotation shaft 9 lies here in the vertical central plane 20. By extending hydraulic cylinder 26 the dredging head 6 will be moved around rotation shaft 9 from port side BB to starboard side SB as according to arrow 27, see figure 3. By subsequently retracting the rod of hydraulic cylinder 26 the dredging head 6 will be moved around rotation shaft 9 from starboard side SB to port side BB as according to arrow 28, see figure 3. The control of dredging head 6 can be further improved by providing an underside of movable connecting part 8b with a number of steering fins 29 which extend in the dragging direction and which are configured to penetrate into the underwater bottom.

[0034] The above described control mechanism makes it possible to control dredging head 6 relative to the course of dredging vessel 1. This is illustrated in figures 2A-2C. Because of the effects of current and the like a dredging vessel 1 will not be able to follow a route precisely corresponding to the desired route of trench 23. In figure 2A dredging vessel 1 is located in a position wherein suction-blow conduit 3 extends substantially vertically downward and is situated directly above the desired route of trench 23. In figure 2B dredging vessel 1 has a position more toward the starboard side SB relative to the desired route. In order to nevertheless move dredging head 6 forward accurately along the route it is steered toward the port side BB. Finally, in figure 2C dredging vessel 1 has a position more toward the port side BB relative to the desired route. In order to nevertheless move dredging head 6 forward accurately along the route it is in this case steered toward the starboard side SB. A trench 23 can in this way be excavated in accurate manner along a predetermined desired route.

[0035] In order to ensure that side walls (23a, 23b) of the formed trench 23 widen upward to some extent (see figure 6) so that suction-blow conduit part 3b can move forward to some extent at an oblique angle in trench 23, side walls of movable connecting part 8b can be provided with laterally extending blades 30. Blades 30 preferably have a concave front surface 30a, wherein front surface 30a faces in an upstream direction during the forming of trench 23. A side edge 30b of blades 30 preferably runs obliquely upward, this such that blades 30 widen toward the top. A trench 23 is hereby obtained which widens a little from the bottom upward.

[0036] With the described dredging head 6 a trench 23 can be formed in accurate manner in an underwater bottom preferably comprising clay. Dredging head 6 is connected here to suction-blow conduit 3 of dredging vessel 1, and a dredge pump (not shown) of dredging vessel 1 carries water through suction-blow conduit 3 in the direction of dredging head 6 while dredging head 6 is moved over the underwater bottom in a dragging direction 7 along an intended route of trench 23. The opening 13 of visor 12 of dredging head 6 facing toward the bottom takes up bottom material dislodged by cutting devices (15a, 15b) and this material is discharged by the generated water flow via the inlet of discharge device 16 connecting to opening 13 to outlets (19a, 19b) of discharge device 16. During movement in dragging direction 7 the thus discharged bottom material is discharged via the outlets to the lateral sides of the formed trench 23 and deposited there.

[0037] If an object has to be buried in the formed trench 23, the formed trench 23 can if desired be filled by moving the bottom material discharged and heaped on the lateral sides into trench 23 with an implement suitable for the purpose, such as a plough, with the proviso that prior to filling thereof the formed trench 23 is provided with the object, for instance a cable or conduit.

[0038] The invention is not limited to the above described embodiment and also comprises modifications thereof, to the extent these fall within the scope of the claims appended below.

REFERENCES CITED IN THE DESCRIPTION

This list of references cited by the applicant is for the reader's convenience only. It does not form part of the European patent document. Even though great care has been taken in compiling the references, errors or omissions cannot be excluded and the EPO disclaims all liability in this regard.

Patent documents cited in the description

- WO0192650A1 [0002]
- WO2013174932A1 [0003]

Krav

1. Gravehoved til udarbejdelse af en rende i en havbund, hvor gravehovedet omfatter en forbindelsesdel med forbindelse til et sugetrykkredsløb på et gravefartøj
5 beregnet til bevægelse i en trækretning, og hvor gravehovedet omfatter en skærm til drejning omkring en horisontal akse på tværs af trækretningen med en åbning, der vender mod bunden til optagning af bundmateriale løsnet af en nedre kant på skærmen, **kendetegnet ved, at** gravehovedet desuden omfatter en udledningsanordning til det løsnede bundmateriale, hvilken udledningsanordning
10 indeholder et indløb til bundmaterialet med forbindelse til åbningen i skærmen og i det mindste et udløb, som er udformet på en sådan måde, at bundmaterialet ved bevægelse i trækretningen kan udledes til i det mindste en lateral side af den udarbejdede rende.
- 15 2. Gravehoved ifølge krav 1, hvor udledningsanordningen omfatter to udløb, som er udformet på en sådan måde, at bundmaterialet ved bevægelse i trækretningen kan udledes på begge laterale sider af den udarbejdede rende.
3. Gravehoved ifølge krav 1 eller 2, hvor udledningsanordningen er forbundet med
20 forbindelsesdelen eller sugetrykkredsløbet med henblik på at kunne dreje omkring en horisontal akse parallelt med trækretningen.
4. Gravehoved ifølge et hvilket som helst af de foregående krav, hvor udledningsanordningen er fastgjort til skærmen eller udgør en del af skærmen.
25
5. Gravehoved ifølge et hvilket som helst af de foregående krav, hvor i det mindste en af hhv. forbindelsesdelen, skærmen og udledningsanordningen er forbundet med sugetrykkredsløbet eller forbindelsesdelen med henblik på at kunne dreje omkring en vertikal akse.

- 5 **6.** Gravehoved ifølge krav 5, hvor den mindst ene drejeforbindelse styres af en aktuator, foretrukket en hydraulisk cylinder.
- 7.** Gravehoved ifølge krav 5 eller 6, hvor forbindelsesdelen er forbundet med sugetrykkredsløbet for at kunne dreje omkring en vertikal akse.
- 10 **8.** Gravehoved ifølge et hvilket som helst af de foregående krav, der desuden omfatter en styrefinne, som strækker sig i trækretningen og er udformet til at trænge ned i havbunden.
- 15 **9.** Gravehoved ifølge krav 8, hvor en underside af forbindelsesdelen omfatter en eller flere styrefinner.
- 10.** Gravehoved ifølge et hvilket som helst af de foregående krav, hvor den nederste kant på skærmen indeholder mindst to serier af skæreværktøjer til at trænge ned i bunden, hvor hver serie strækker sig langs en linje på tværs af trækretningen, og
20 hvor den første serie skæreværktøjer trænger mindre dybt ned i bunden end den anden serie skæreværktøjer placeret efter den første serie.
- 11.** Gravehoved ifølge et hvilket som helst af de foregående krav, hvor forbindelsesdelen omfatter to laterale vægge, og væggene er forsynet med skovle,
25 der strækker sig lateralt.
- 12.** Graveanordning til at udarbejde en rende i en havbund, omfattende et gravefartøj beregnet til bevægelse i en trækretning og et gravehoved ifølge et hvilket som helst af kravene 1-11 forbundet med et sugetrykkredsløb på et gravefartøj.
30
- 13.** Graveanordning ifølge krav 12, desuden omfattende en styremekanisme til at styre gravehovedet, hvor den mindst ene drejeforbindelse på gravehovedet styres af en aktuator, og styremekanismen er beregnet til at styre aktuatoren.

14. Fremgangsmåde til at fremstille en rende i en havbund med en graveanordning ifølge et hvilket som helst af kravene 12-13, hvor gravehovedet er forbundet med sugetrykkredsløbet på gravefartøjet, en opmudringspumpe på gravefartøjet fører vand gennem sugetrykkredsløbet i retning mod gravehovedet, og gravehovedet bevæges over havbunden i en trækretning langs en planlagt rute af

5 renden, **kendetegnet ved, at** en åbning i skærmen på gravehovedet, som vender mod bunden, optager bundmateriale løsnet af en nedre kant på skærmen, og via indløbet på udledningsanordningen forbundet med åbningen i skærmen udleder dette materiale til det mindst ene udløb på udledningsanordningen, som er udformet

10 på en sådan måde, at bundmaterialet ved bevægelse i trækretningen kan udledes til i det mindste en lateral side af den udarbejdede rende.

15. Fremgangsmåde ifølge krav 14, hvor den udarbejdede rende fyldes ved at bevæge bundmaterialet, som er udledt og anbragt på i det mindste en lateral side,

15 ned i renden med et arbejdsredskab egnet til formålet, f.eks. en plov, og hvor den udarbejdede rende er forsynet med et emne, som f.eks. et kabel eller kredsløb, forud for fyldning af denne.

DRAWINGS

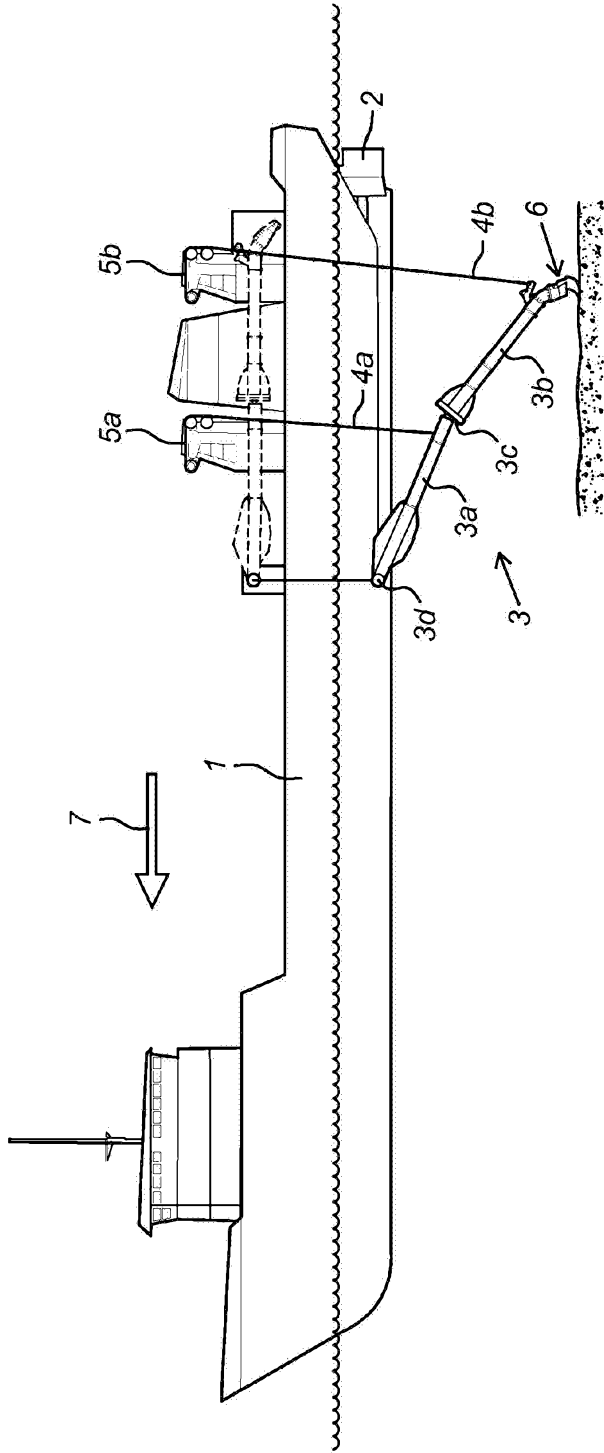
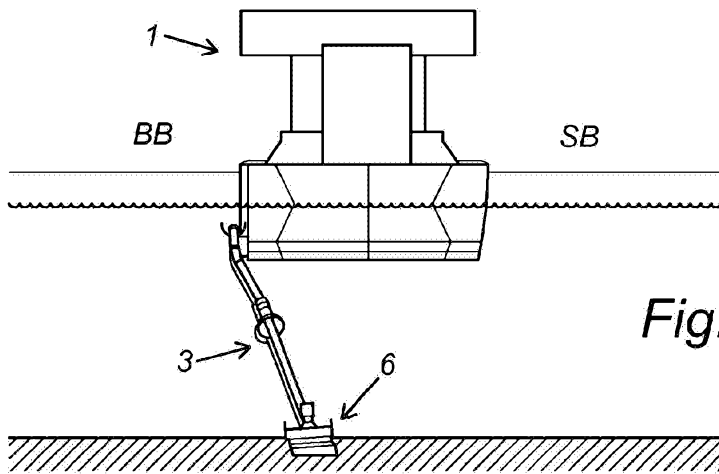
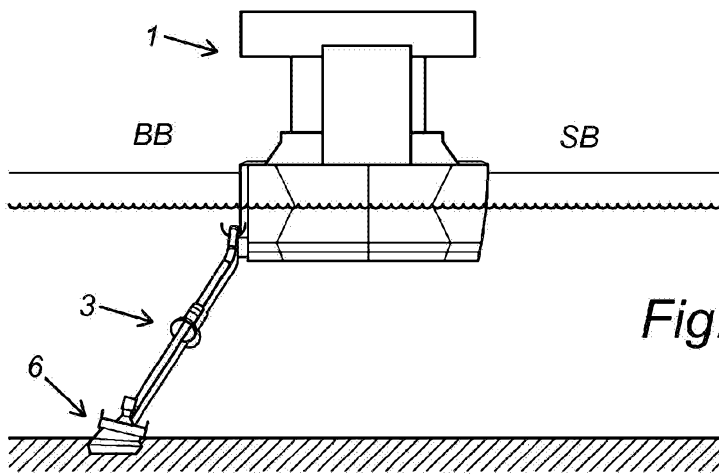
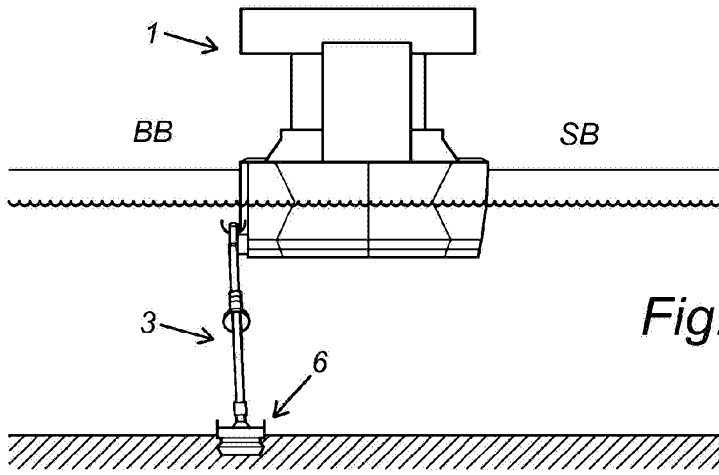

Fig. 1



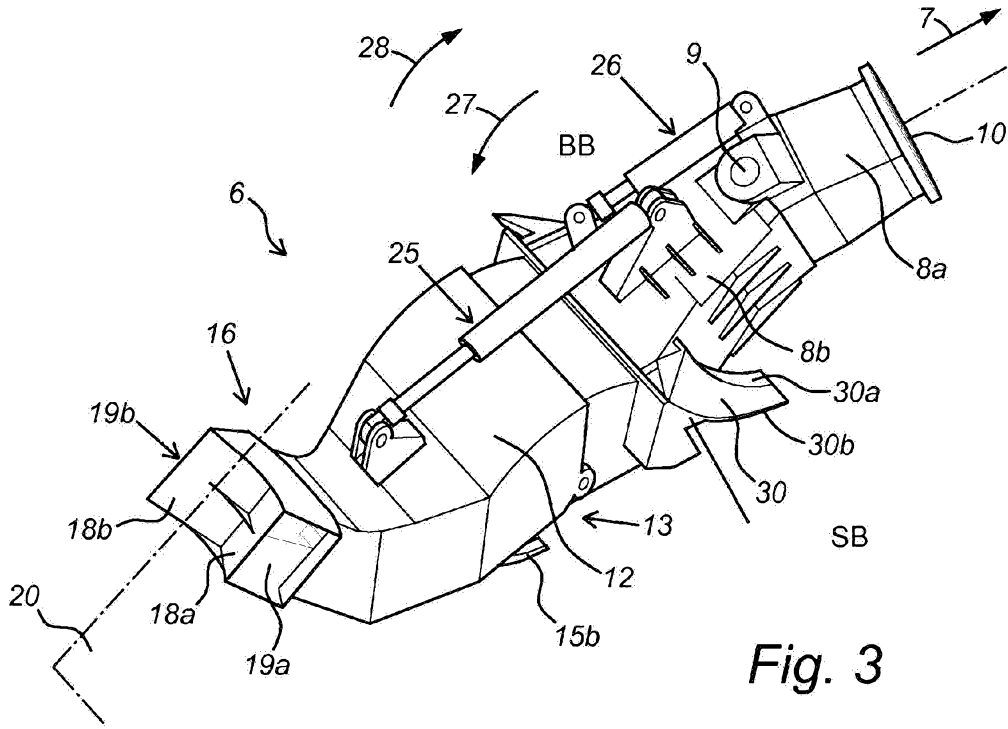

Fig. 3

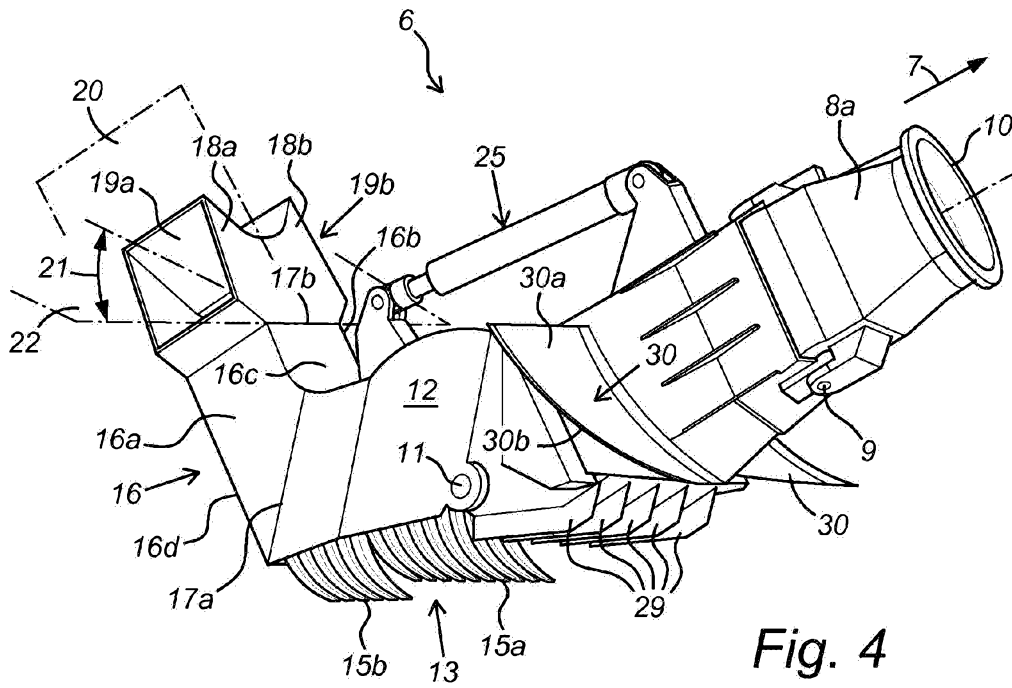

Fig. 4

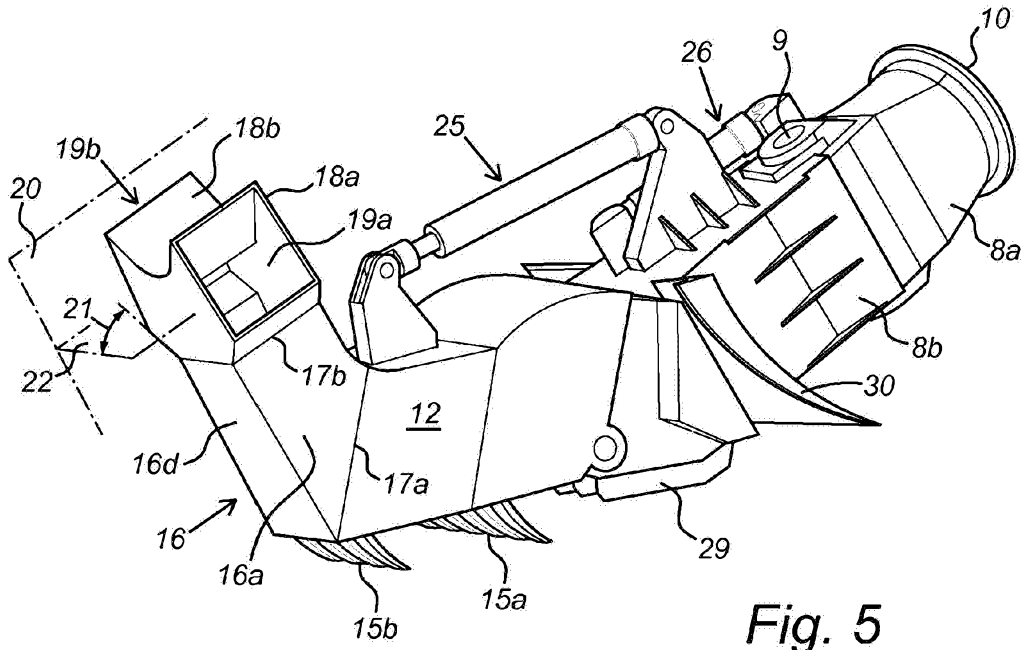

Fig. 5

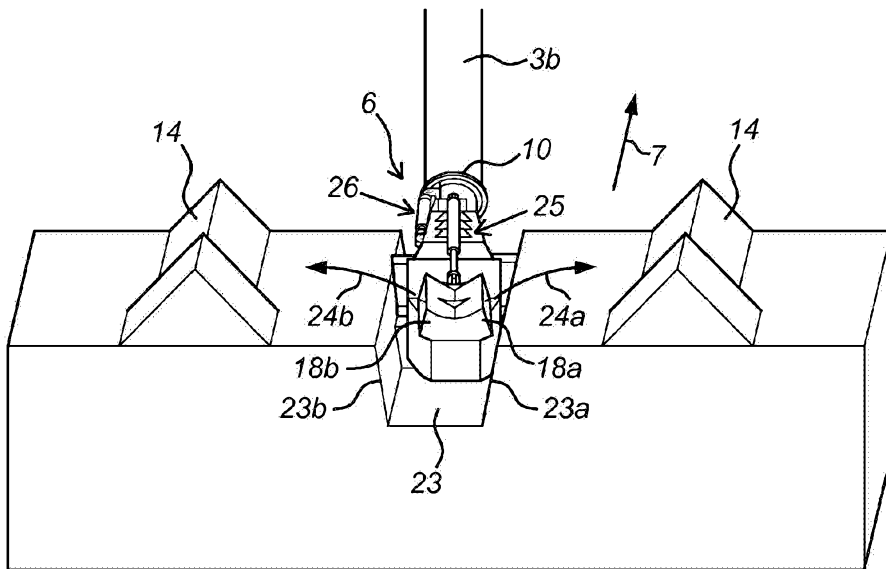

Fig. 6