

(19) World Intellectual Property Organization
International Bureau



(43) International Publication Date
15 May 2008 (15.05.2008)

PCT

(10) International Publication Number
WO 2008/057328 A2

(51) International Patent Classification:
A61L 31/14 (2006.01)

(74) Agents: CANNING, Kevin, J. et al.; Lahive & Cockfield, LLP, One Post Office Square, Boston, MA 02109-2127 (US).

(21) International Application Number:
PCT/US2007/022860

(81) Designated States (unless otherwise indicated, for every kind of national protection available): AE, AG, AL, AM, AT, AU, AZ, BA, BB, BG, BH, BR, BW, BY, BZ, CA, CH, CN, CO, CR, CU, CZ, DE, DK, DM, DO, DZ, EC, EE, EG, ES, FI, GB, GD, GE, GH, GM, GT, HN, HR, HU, ID, IL, IN, IS, JP, KE, KG, KM, KN, KP, KR, KZ, LA, LC, LK, LR, LS, LT, LU, LY, MA, MD, ME, MG, MK, MN, MW, MX, MY, MZ, NA, NG, NI, NO, NZ, OM, PG, PH, PL, PT, RO, RS, RU, SC, SD, SE, SG, SK, SL, SM, SV, SY, TJ, TM, TN, TR, TT, TZ, UA, UG, US, UZ, VC, VN, ZA, ZM, ZW.

(22) International Filing Date: 30 October 2007 (30.10.2007)

(25) Filing Language: English

(26) Publication Language: English

(30) Priority Data:
60/856,983 6 November 2006 (06.11.2006) US

(71) Applicant (for all designated States except US): ATRIUM MEDICAL CORPORATION [US/US]; 5 Wentworth Drive, Hudson, NH 03051 (US).

(84) Designated States (unless otherwise indicated, for every kind of regional protection available): ARIPO (BW, GH, GM, KE, LS, MW, MZ, NA, SD, SL, SZ, TZ, UG, ZM, ZW), Eurasian (AM, AZ, BY, KG, KZ, MD, RU, TJ, TM), European (AT, BE, BG, CH, CY, CZ, DE, DK, EE, ES, FI, FR, GB, GR, HU, IE, IS, IT, LT, LU, LV, MC, MT, NL, PL, PT, RO, SE, SI, SK, TR), OAPI (BF, BJ, CF, CG, CI, CM, GA, GN, GQ, GW, ML, MR, NE, SN, TD, TG).

(72) Inventors; and

(75) Inventors/Applicants (for US only): HERWECK, Steve, A. [US/US]; 4 Crestwood Lane, Nashua, NH 03062 (US). FERRARO, Joseph [US/US]; 36 Sherwood Road, Londonderry, NH 03053 (US). MARTAKOS, Paul [US/US]; 1 Regis Drive, Pelham, NH 03076 (US). KARWOSKI, Theodore [US/US]; 61 Hannah Drive, Hollis, NH 03049 (US). HORTON, Anthony, Richard [US/US]; 629 Belmont Street, Manchester, NH 03104 (US).

Published:
— without international search report and to be republished upon receipt of that report

(54) Title: TISSUE SEPARATING DEVICE WITH REINFORCED SUPPORT FOR ANCHORING MECHANISMS

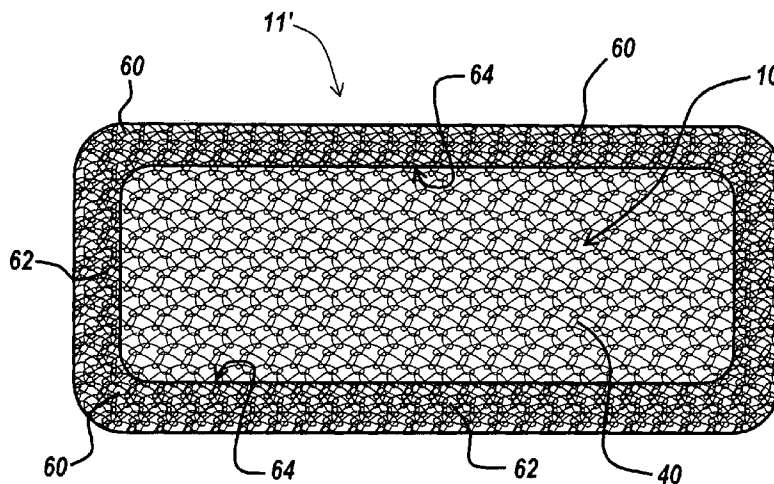

(57) Abstract: A barrier layer device is formed of an underlying biocompatible structure having a barrier layer coating that can exhibit anti-inflammatory properties, non-inflammatory properties, and/or adhesion-limiting properties, as well as generate a modulated healing effect on injured tissue. As implemented herein, the barrier layer is a non-polymeric cross-linked gel derived at least in part from a fatty acid compound, and may include a therapeutic agent. The underlying structure can be in the form of a surgical mesh. The barrier device is further provided with reinforced sections or portions to aid with the fastening of the barrier device for implantation purposes and prohibits or substantially reduces the occurrence of excessive stretching and tearing. The barrier device is implantable in a patient for short term or long term applications, and can include controlled release of the therapeutic agent.

WO 2008/057328 A2

TISSUE SEPARATING DEVICE WITH REINFORCED SUPPORT FOR ANCHORING MECHANISMS

RELATED APPLICATION

[0001] This application claims priority to, and the benefit of, co-pending United States Provisional Application 60/856983, filed November 6, 2006, for all subject matter common to both applications. The disclosure of said provisional application is hereby incorporated by reference in its entirety.

FIELD OF THE INVENTION

[0002] The present invention relates to implantable devices forming separating layers, and more particularly to a device having an internal reinforced support structure for temporary or permanent tissue anchoring mechanisms, that is able to deliver therapeutic agents to a targeted location, as desired, and makes use of one or more modulated healing or adhesion limiting surfaces. The reinforced anchoring support structure has locations of improved mechanical strength for surgically fixating or anchoring the device to soft tissue during implantation.

BACKGROUND OF THE INVENTION

[0003] Biocompatible medical films are most often used in surgical settings as a physical barrier to help separate certain organs from adjacent tissues and medical devices following surgical intervention or blunt dissection to minimize adhesion formation. For example, SEPRAFILM®, a product of Genzyme Corporation of Cambridge, MA, is used in patients undergoing either open or laparoscopic abdominal or pelvic surgeries as an implantable treatment intended to reduce the incidence, extent, and severity of postoperative adhesion formation between different tissues and organs and implantable medical devices such as soft tissue support membranes and mesh, or combinations of non-absorbable films and meshes.

[0004] US Patent No. 5,017,229 is directed to a water insoluble, biocompatible gel that includes the reaction product of hyaluronic acid, a polyanionic polysaccharide, and an activating agent. The gel described in the '229 patent can be provided in the form of an

adhesion prevention composition, such as a membrane or composition suitable for incorporation into a syringe. The gel is described as being able to form a film by being cast into a sheet form, extruded, compressed, or allowed to dehydrate in a flat sheet. When modified with polysaccharide, the biodegradable film forms the above-described SEPRAFILM® adhesion-limiting or adhesion barrier product made commercially available as a dehydrated bio-dissolvable single layer sheet.

[0005] However, such commercially available adhesion prevention and adhesion barrier film products often can be difficult to handle and apply to the targeted location due to their chemical make up and rapid bio-dissolvable properties. The composition and limited structural strength properties of these bio-dissolvable products result in the material that forms the products softening relatively quickly upon exposure to fluids, thus making handling difficult during most open and laparoscopic surgical intervention operations. Furthermore, many of these bio-dissolvable films are made intentionally to be thin and without reinforcement or anchoring support to minimize tissue disruption. Consequently, these films end up being structurally weak (i.e., easily torn or folded during handling). These characteristics of the film products result in a very low level of mechanical fixation integrity and a very low level of handling stability during surgical manipulation and implantation. It should be noted that these characteristics are intentional, principally to enhance rapid body fluid absorption and subsequent chemical breakdown and liquefaction by body fluids for complete absorption and removal by the body. Chemically stabilized adhesion prevention film products engineered solely for adhesion prevention or temporary barrier separation are also known to be difficult to handle during surgery because of a tendency for the materials to adhere to themselves, and are known to tear and fold undesirably during handling and implantation.

[0006] Surgical meshes, which are used to reinforce weakened areas of abdominal, pelvic, or thoracic tissues, or to replace a portion of internal structural soft tissue that has neither been damaged nor removed surgically, can also be made to have anti-adhesion properties. PCT Application Publication No. WO 2004/028583 is directed to compositions, devices, and methods for maintaining or improving the integrity of body passageways following surgery or injury. Surgical mesh drug eluting delivery devices can include one or more therapeutic agents provided with a drug eluting mesh wrap implant placed adjacent to medical devices and internal tissue as described therein. The meshes are available in various

single layer, multi-layer, and 3-dimensional configurations made without bioabsorbable adhesion coatings and films. The meshes are most often constructed of synthetic non-absorbable polymer materials, such as polyethylene, polytetrafluoroethylene, and polypropylene, and can include a carrier having a therapeutic agent attached thereto, incorporated within, or coated thereon. The mesh structure for this surgical application serves as a drug eluting delivery apparatus for local therapeutic delivery within the body. Affixing the carrier and or coating directly onto the surgical mesh makes it easier to handle the device without the drawbacks of film, namely tearing, folding, and rapid dissolving when contacting body fluids, and the lack of fixation or anchoring means. Non-absorbable mesh structures generally provide more handling strength and directional placement control during installation than bio-absorbable or bio-dissolvable polymer films. However, surgical mesh structures are not structurally designed to create a separating layer between tissue and/or medical devices due to their inherent porous structure. Such devices do enable some form of mechanical fixation or anchoring ability not possible with films, but the strength of the mesh structures can be insufficient to adequately hold fixation and anchoring devices without tearing, material disruption, elongation, and/or separation from its anchoring mechanism(s).

[0007] For most surgical procedures involving internal tissue reconstruction, dissection, or soft tissue repair, there is often a need to reinforce the surgically affected area with a non-absorbable implantable structure (such as a mesh or porous polymeric film). Such devices require an anchor, suture, adhesive, or tack to hold the mesh (or other device) in place within the patient's body to avoid migration, material separation, folding, wrinkling, or clumping of the implanted device after the surgery is complete.

[0008] Known implantable reinforcement devices, including non-absorbable surgical mesh and porous polymer films, are designed to promote either uninhibited cellular in-growth or limited cellular in-growth through the medical device over time. After tissue begins growing into and through the surgically implanted porous mesh or film, the implanted device is further anchored or held in place by that ingrown tissue, in addition to the surgically applied mechanical anchoring means. However, prior to such tissue in-growth, which can take days, weeks, or even months, depending on the condition of the patient and the location of the implant and damaged tissue, it is necessary to hold the mesh, or other device, in place with such fasteners as anchors, sutures, tacks, or adhesives.

[0009] These various mechanical fasteners involve either passage directly through an existing hole in the porous implant, or forcibly puncturing the implant, forming a new button hole or other aperture through the device, causing some damage to the material during the anchoring process. Apertures or points of anchoring created in the porous mesh and film devices are subject to increased mechanical stress because the fastener or adhesive applying additional force against the apertures or points of anchoring to hold the implant in place against soft tissue. These increased fixation stresses have, at times, resulted in the device becoming separated from its anchoring mechanism due to excessive material stretching and/or tearing. At the apertures or points of anchoring, the underlying tissue during normal physical activity can sometimes unpredictably pull the anchoring means through the aperture or button hole, leaving this portion of the implanted device un-anchored. Even more problematic for the medical user is that when tensioning the implant to remove folds or wrinkles, an anchored location pulls free, or pulls through the mesh device.

[0010] The tearing of the device at or near areas of anchoring mechanisms, depending on the particular fastener used, can allow the implanted device to become disrupted from its preferred location, or to lift up and off the anchoring mechanism, leaving the non-attached portion of the device disconnected from the tissue it was meant to reinforce. The excessive stretching and tearing, either during surgical installation or following surgery during normal physical activity can result in complications derived from the implant becoming un-anchored or disconnected from the tissue, which can be clinically detrimental to the patient. Such detachment events are often referred to as “re-occurrences”, and generally require surgical re-intervention, additional blunt dissection, or separation of adjoining tissues to re-establish a desirable and anatomically suitable fixation spot to re-attach the implant material. In the event the implant anchoring hole has torn or has elongated under stress conditions, often the implant cannot be repaired or re-attached at the location of the tear or stretch, thus requiring removal of the implant and/or introduction of a replacement implant device, requiring additional anchors to new tissue locations to patch over the damage caused by the events related to the first implant.

SUMMARY

[0011] A tissue separating layer implantable device is provided, with or without the ability to deliver therapeutic agents, but having a structure predisposed to promoting tissue

in-growth on one side and providing adhesion-limiting characteristics on an opposite side, with one or more surfaces that modulate healing, and limit or reduce the degree of adhesion formation with adjacent tissues and/or other medical devices, while also being reinforced to prevent or substantially reduce the occurrence of excessive stretching and tearing at locations of anchoring, and to prevent anchors from passing through the device and releasing. The anchoring of the device to the tissue can occur with adhesive, sutures, staples, tacks, or other anchoring or fastening devices commonly applied for affixing mesh or film directly to tissue.

[0012] Accordingly, the present invention includes a biocompatible surgical mesh structure, with one or more anchoring support elements coupled thereto, and a barrier layer formed on or with at least portions of the surgical mesh and the anchoring support element. The barrier layer, uniformly impregnated into portions of the porous mesh structure and anchoring support elements, combines and holds the surgical mesh, the anchoring support element, and any additional layers together. The resulting device has little to no multi-layer distinction, other than an increased thickness at anchoring support element locations. The anchoring support element can also be in the form of a surgical mesh, or other constructions having different porosities, structures, and characteristics, including alternative materials, and provides added strength to the surgical mesh to avoid unwanted anchoring device separation due to tearing or stretching at anchoring locations during implantation of the device, and during post-operative conditions of normal physical activity by the patient.

BRIEF DESCRIPTION OF THE FIGURES

[0013] These and other characteristics of the present invention will be more fully understood by reference to the following detailed description in conjunction with the attached drawings, in which:

[0014] **FIG. 1** a diagrammatic illustration of a barrier layer realized as a stand alone film, according to one embodiment of the present invention;

[0015] **FIGS. 2A, 2B, and 2C** are cross-sectional views of the barrier layer in accordance with one aspect of the present invention;

[0016] **FIGS. 3A, 3B, 3C, 3D, 3E, and 3F** are diagrammatic views of the barrier layer in accordance with another aspect of the present invention;

- [0017] **FIG. 4** is a flow chart illustrating a method of making the barrier layer of the present invention, in accordance with one embodiment of the present invention;
- [0018] **FIGS. 5A** and **5B** are perspective and cross-sectional views of the barrier layer in combination with a medical device, in accordance with one embodiment of the present invention;
- [0019] **FIG. 6** is a flow chart illustrating a method of combining the barrier layer with a medical device, in accordance with one embodiment of the present invention;
- [0020] **FIG. 7** is a flow chart illustrating another variation of the method of **FIG. 6**, in accordance with one embodiment of the present invention;
- [0021] **FIGS. 8A, 8B,** and **8C** are diagrammatic illustrations of the barrier coupled with various medical devices;
- [0022] **FIG. 9** is a diagrammatic illustration of a barrier device, formed of a mesh medical device in combination with the barrier layer, and further including a reinforcement element, in accordance with one embodiment of the present invention;
- [0023] **FIG. 10** is a zoomed in perspective illustration of a corner of the barrier device of **FIG. 9**, in accordance with one embodiment of the present invention;
- [0024] **FIG. 11** is a diagrammatic illustration of a barrier device demonstrating a variety of different reinforcement elements, in accordance with a plurality of embodiments of the present invention;
- [0025] **FIG. 12** is a cross-sectional illustration of the barrier device of **FIG. 9**, in accordance with one aspect of the present invention;
- [0026] **FIG. 13** is a flowchart illustrating a method of combining the barrier layer with a mesh medical device with anchoring support element to form a barrier device, in accordance with one embodiment of the present invention;
- [0027] **FIG. 14** is a diagrammatic illustration of a barrier device having multiple layers of anchoring support elements, in accordance with a plurality of embodiments of the present invention; and
- [0028] **FIGS. 15A** and **15B** are diagrammatic illustrations of additional embodiments of barrier devices having anchoring support elements of varying structural properties, in accordance with aspects of the present invention.

DETAILED DESCRIPTION

[0029] An illustrative embodiment of the present invention relates to the provision of a barrier layer that can exhibit modulated healing properties, anti-inflammatory properties, non-inflammatory properties, and/or adhesion-limiting properties, and corresponding method of making, along with a combined barrier layer and medical device, to form a barrier device. The barrier layer itself can be combined with another medical device, such as a device having a mesh structure, which can provide underlying internal support to the barrier layer while the barrier layer can provide any of the above mentioned properties to the medical device, in addition to improved healing and delivery of therapeutic agents. The barrier layer is generally formed of a biocompatible oil, or an oil composition formed in part of a biocompatible oil. In addition, the oil composition can include a therapeutic agent component, such as a drug or other bioactive agent. As implemented herein, the barrier layer is a non-polymeric cross-linked gel derived at least in part from a fatty acid compound. The barrier layer in the present invention is combined with an underlying structure, such as a surgical mesh, to create the inventive barrier device. The barrier device includes one or more anchoring support elements that reinforce the device at locations where the device is anchored to the soft tissue of the patient. The anchoring support elements improve internal hole stability, resistance to hole elongation, disruption, or tearing, and resistance to material separation from support tissue while also healing the underlying tissue. The barrier device of the present invention is implantable in a patient for short term or long term applications, and can include controlled release of the therapeutic agent.

[0030] There are a number of terms and phrases utilized herein that are well understood by those of ordinary skill in the art. Additional clarification and confirmation of some of these terms and phrases is provided immediately below and throughout this disclosure.

[0031] The term "bio-absorbable" generally refers to having the property or characteristic of being able to penetrate the tissue of a patient's body. In certain embodiments of the present invention bio-absorption occurs through a lipophilic mechanism. The bio-absorbable substance is soluble in the phospholipid bi-layer of cells of body tissue, and therefore impacts how the bio-absorbable substance penetrates into the cells.

[0032] It should be noted that a bio-absorbable substance is different from a biodegradable substance. Biodegradable is generally defined as capable of being decomposed by biological agents, or capable of being broken down by microorganisms or

biological processes, in a manner that does not result in cellular uptake or absorption of the biodegradable substance. Biodegradation thus relates to the breaking down and distributing of a substance through the patient's body, versus the consumption by or penetration into the localized cells of the patient's body tissue. Biodegradable substances, such as polymers, can cause inflammatory response due to either the parent substance or those substances formed during breakdown, and they may or may not be absorbed by tissues. Bio-absorbable substances break down into substances or components that do not cause an inflammatory response and can be consumed by the cells forming the body tissues.

[0033] The phrase "controlled release" generally refers to the release of a biologically active agent in a predictable manner over a desired period of time. Controlled release includes the provision of an initial burst of release upon implantation, followed by the predictable release over the predetermined time period. Accordingly, controlled release includes such embodiments as those that release substantially all or a significant portion of the biologically active agent in a predictable manner, and a substantially lesser amount of the biologically active agent for a duration thereafter. Additional embodiments include delivery of a biologically active agent to a targeted location along with the bioabsorbable gel components at the cellular level

[0034] It should be noted that the phrase "cross-linked gel", as utilized herein with reference to the present invention, refers to a gel that is non-polymeric and is derived from an oil composition comprising molecules covalently cross-linked into a three-dimensional network by one or more of ester, ether, peroxide, and carbon-carbon bonds in a substantially random configuration that can reversibly convert into oil compounds. In various preferred embodiments, the oil composition comprises a fatty acid molecule, a glyceride, and combinations thereof.

[0035] Furthermore, "curing" with respect to the present invention generally refers to thickening, hardening, or drying of a material brought about by heat, UV light, chemical means, reaction with biologically active agent and/or reactive gasses.

[0036] Modulated healing is intended to refer to the in-vivo effect observed post-implant in which the biological response is altered resulting in a significant reduction in foreign body response. As utilized herein, the phrase "modulated healing" and variants of this language

generally refers to a process involving different cascades or sequences of naturally occurring tissue repair in response to localized tissue injury. Modulated healing encompasses many different biologic processes, including epithelial growth, fibrin deposition, platelet activation and attachment, inhibition, proliferation and/or differentiation, connective fibrous tissue production and function, angiogenesis, and several stages of acute and/or chronic inflammation, and their interplay with each other. The reversibly cross-linked gel of the barrier layer has been shown experimentally in animal models not to produce or induce a protracted inflammatory response and not to lead to excessive formation of connective fibrous tissue following tissue injury. The reversibly cross-linked gel of the tissue separating layer has also been shown experimentally in animal models not to produce or induce a fibrin deposition and platelet attachment to a blood contact surface following vascular injury. Likewise, the reversibly cross-linked gel of the barrier layer has exhibited a complimentary or synergistic modulated healing effect. Such a healing effect results in a less dense, but uniformly confluent cellular overgrowth of a porous implanted mesh structure with little to no fibrous capsule formation, which is otherwise commonly seen with conventional permanent mechanical barrier devices on the implant device. Accordingly, the cross-linked gel of the barrier layer 10 provides an excellent absorbable cellular interface suitable for use with a surgical implant with reinforced anchoring support that results in a modulated healing effect, avoiding the generation of scar tissue and promoting the formation of healthy tissue at a modulated or delayed period in time following the injury.

[0037] It should be noted that as utilized herein, the term fish oil fatty acid includes but is not limited to omega-3 fatty acid, fish oil fatty acid, free fatty acid, monoglycerides, diglycerides, or triglycerides, esters of fatty acids, or a combination thereof. The fish oil fatty acid includes one or more of arachidic acid, gadoleic acid, arachidonic acid, eicosapentaenoic acid, docosahexaenoic acid or derivatives, analogs and pharmaceutically acceptable salts thereof. Furthermore, as utilized herein, the term free fatty acid includes but is not limited to one or more of butyric acid, caproic acid, caprylic acid, capric acid, lauric acid, myristic acid, palmitic acid, palmitoleic acid, stearic acid, oleic acid, vaccenic acid, linoleic acid, alpha-linolenic acid, gamma-linolenic acid, behenic acid, erucic acid, lignoceric acid, analogs and pharmaceutically acceptable salts thereof. The biocompatible oils, including fish oil, are cured as described herein to form a hydrophobic cross-linked gel, creating the barrier layer 10.

[0038] Likewise, it should be noted that as utilized herein to describe the present invention, the term "vitamin E" and the term "alpha and gamma-tocopherols", are intended to refer to the same or substantially similar substance, such that they are interchangeable and the use of one includes an implicit reference to both. Further included in association with the term vitamin E are such variations including but not limited to one or more of alpha and gamma-tocopherols, beta-tocopherol, delta-tocopherol, gamma-tocopherol, alpha-tocotrienol, beta-tocotrienol, delta-tocotrienol, gamma-tocotrienol, alpha and gamma-tocopherols acetate, beta-tocopherol acetate, gamma-tocopherol acetate, delta-tocopherol acetate, alpha-tocotrienol acetate, beta-tocotrienol acetate, delta-tocotrienol acetate, gamma-tocotrienol acetate, alpha and gamma-tocopherols succinate, beta-tocopherol succinate, gamma-tocopherol succinate, delta-tocopherol succinate, alpha-tocotrienol succinate, beta-tocotrienol succinate, delta-tocotrienol succinate, gamma-tocotrienol succinate, mixed tocopherols, vitamin E TPGS, derivatives, analogs and pharmaceutically acceptable salts thereof.

[0039] With regard to the aforementioned oils, it is generally known that the greater the degree of unsaturation in the fatty acids the lower the melting point of a fat, and the longer the hydrocarbon chain the higher the melting point of the fat. A polyunsaturated fat, thus, has a lower melting point, and a saturated fat has a higher melting point. Those fats having a lower melting point are more often oils at room temperature. Those fats having a higher melting point are more often waxes or solids at room temperature. Therefore, a fat having the physical state of a liquid at room temperature is an oil. In general, polyunsaturated fats are liquid oils at room temperature, and saturated fats are waxes or solids at room temperature.

[0040] Polyunsaturated fats are one of four basic types of fat derived by the body from food. The other fats include saturated fat, as well as monounsaturated fat and cholesterol. Polyunsaturated fats can be further composed of omega-3 fatty acids and omega-6 fatty acids. Under the convention of naming the unsaturated fatty acid according to the position of its first double bond of carbons, those fatty acids having their first double bond at the third carbon atom from the methyl end of the molecule are referred to as omega-3 fatty acids. Likewise, a first double bond at the sixth carbon atom is called an omega-6 fatty acid. There can be both monounsaturated and polyunsaturated omega fatty acids.

[0041] Omega-3 and omega-6 fatty acids are also known as essential fatty acids because they are important for maintaining good health, despite the fact that the human body cannot make them on its own. As such, omega-3 and omega-6 fatty acids must be obtained from external sources, such as food. Omega-3 fatty acids can be further characterized as containing eicosapentaenoic acid (EPA), docosahexanoic acid (DHA), and alpha-linolenic acid (ALA). Both EPA and DHA are known to have anti-inflammatory effects and wound healing effects within the human body.

[0042] Oil that is hydrogenated becomes a waxy solid. Attempts have been made to convert the polyunsaturated oils into a wax or solid to allow the oil to adhere to a device for a longer period of time. One such approach is known as hydrogenation, which is a chemical reaction that adds hydrogen atoms to an unsaturated fat (oil) thus saturating it and making it solid at room temperature. This reaction requires a catalyst, such as a heavy metal, and high pressure. The resultant material forms a non-cross linked semi-solid. Hydrogenation can reduce or eliminate omega-3 fatty acids and any therapeutic effects (both anti-inflammatory and wound healing) they offer.

[0043] For long term controlled release applications, synthetic polymers, as previously mentioned, have been utilized in combination with a therapeutic agent. Such a combination provides a platform for the controlled long term release of the therapeutic agent from a medical device. However, synthetic polymer coatings have been determined to cause inflammation in body tissue. Therefore, the polymer coatings often must include at least one therapeutic agent that has an anti-inflammatory effect to counter the inflammation caused by the polymer delivery agent. In addition, patients that receive a synthetic polymer coating based implant must also follow a course of systemic anti-inflammatory therapy, to offset the inflammatory properties of the non-absorbable polymer. Typical anti-inflammatory agents are immunosuppressants and systemic delivery of anti-inflammatory agents can sometimes lead to additional medical complications, such as infection or sepsis, which can lead to long term hospitalization or death. Use of the non-polymeric cross-linked gel of the inventive barrier layer described herein can negate the necessity of anti-inflammatory therapy, and the corresponding related risks described, because there is no inflammatory reaction to the oil barrier.

[0044] The term “barrier” or “barrier layer” is utilized to two primary ways in the present application. A “barrier layer” is intended to refer to a device that can be a stand-alone film or can be a coating or layer placed on another medical device. In both instance, the barrier layer serves as a barrier between tissue of a patient and either a medical device or other tissue. A “barrier layer device” is intended to relate to a device having a barrier layer applied thereto as a layer or coating, or encapsulating the underlying medical device, as later described herein.

[0045] **FIGS. 1 through 15B**, wherein like parts are designated by like reference numerals throughout, illustrate example embodiments of non-polymeric biological and physical oil barrier layers and barrier devices according to the present invention. Although the present invention will be described with reference to the example embodiments illustrated in the figures, it should be understood that many alternative forms can embody the present invention. One of ordinary skill in the art will additionally appreciate different ways to alter the parameters of the embodiments disclosed, such as the size, shape, or type of elements or materials, in a manner still in keeping with the spirit and scope of the present invention.

[0046] **FIG. 1** illustrates a non-polymeric biological oil barrier layer 10 in accordance with one embodiment of the present invention. The barrier layer 10 is flexible, to the extent that it can be placed in a flat, curved, or rolled, configuration within a patient. The barrier layer 10 is implantable, for both short term and long term applications. Depending on the particular formulation of the barrier layer 10, the barrier layer 10 will be present after implantation for a period of hours to days, weeks, or possibly months.

[0047] The barrier layer 10 is formed of an oil component. The oil component can be either an oil, or an oil composition. The oil component can be a naturally occurring oil, such as fish oil, cod liver oil, cranberry oil, or other oils having desired characteristics. One example embodiment of the present invention makes use of a fish oil in part because of the high content of omega-3 fatty acids, which provide healing support for damaged tissue, as discussed below. The fish oil also serves as an adhesion-limiting agent. In addition, the fish oil maintains anti-inflammatory or non-inflammatory properties as well. The present invention is not limited to formation of the film with fish oil as the naturally occurring oil. However, the following description makes reference to the use of fish oil as one example

embodiment. Other naturally occurring oils can be utilized in accordance with the present invention as described herein.

[0048] It should further be noted that **FIG. 1** represents merely one embodiment of the barrier layer 10. The barrier layer 10 serves as a biological oil barrier and, depending on degree of cure, can also serve as a physical barrier, as depicted. The biological oil barrier is represented by the application of the fatty acid based oil, such as fish oil, onto a medical device. Such a configuration provides a biological oil barrier layer that provides a non-inflammatory or anti-inflammatory barrier coating. Using a number of different methods as described below, the biological oil can be cured to create a non-polymeric cross-linked gel. In the instance of the medical device taking the form of a surgical mesh, the biological oil can be cured to the extent that the cells or pores of the mesh are substantially or completely bridged by the cured biological oil creating a physical barrier. With such a configuration there can remain some biological oil that is not cured but is inter-dispersed within the cured oil and maintains the biological oil barrier layer 10 as well. Thus, substantial curing creates both a biological oil barrier layer and a physical barrier or tissue separating layer. The physical barrier provides modulated healing and adhesion-limiting properties of the barrier as discussed herein. Additional embodiments can include the provision of the substantially cured oil forming the biological oil barrier layer with physical layer, and then a subsequent application of the biological oil as a top coat. This creates a more substantial biological oil barrier layer supported by the combination biological oil barrier layer and physical barrier layer. Other embodiments can include the provision of a partially or substantially cured biological oil barrier layer that coats all or a portion of a surgical mesh without bridging the cells of the mesh. In such embodiments, the biological oil forms a barrier between the body tissue at the location of implantation and the physical structure of the mesh or other device.

[0049] Prior to further describing the invention, it may be helpful to an understanding thereof to generally and briefly describe injury and the biological response thereto.

[0050] Vascular injury causing intimal thickening can be broadly categorized as being either biologically or mechanically induced. Biologically mediated vascular injury includes, but is not limited to, injury attributed to infectious disorders including endotoxins and herpes viruses, such as cytomegalovirus; metabolic disorders, such as atherosclerosis; and vascular injury resulting from hypothermia, and irradiation. Mechanically mediated vascular injury

includes, but is not limited to, vascular injury caused by catheterization procedures or vascular scraping procedures, such as percutaneous transluminal coronary angioplasty; vascular surgery; transplantation surgery; laser treatment; and other invasive procedures which disrupt the integrity of the vascular intima or endothelium. Generally, neointima formation is a healing response to a vascular injury.

[0051] Wound healing upon vascular injury occurs in several stages. The first stage is the inflammatory phase. The inflammatory phase is characterized by hemostasis and inflammation. Collagen exposed during wound formation activates the clotting cascade (both the intrinsic and extrinsic pathways), initiating the inflammatory phase. After injury to tissue occurs, the cell membranes, damaged from the wound formation, release thromboxane A₂ and prostaglandin 2- α , which are potent vasoconstrictors. This initial response helps to limit hemorrhage. After a short period, capillary vasodilatation occurs secondary to local histamine release, and the cells of inflammation are able to migrate to the wound bed. The timeline for cell migration in a normal wound healing process is predictable. Platelets, the first response cell, release multiple chemokines, including epidermal growth factor (EGF), fibronectin, fibrinogen, histamine, platelet-derived growth factor (PDGF), serotonin, and von Willebrand factor. These factors help stabilize the wound through clot formation. These mediators act to control bleeding and limit the extent of injury. Platelet degranulation also activates the complement cascade, specifically C5a, which is a potent chemoattractant for neutrophils.

[0052] As the inflammatory phase continues, more immune response cells migrate to the wound. The second response cell to migrate to the wound, the neutrophil, is responsible for debris scavenging, complement-mediated opsonization of bacteria, and bacteria destruction via oxidative burst mechanisms (i.e., superoxide and hydrogen peroxide formation). The neutrophils kill bacteria and decontaminate the wound from foreign debris.

[0053] The next cells present in the wound are the leukocytes and the macrophages (monocytes). The macrophage, referred to as the orchestrator, is essential for wound healing. Numerous enzymes and cytokines are secreted by the macrophage. These include collagenases, which debride the wound; interleukins and tumor necrosis factor (TNF), which stimulate fibroblasts (produce collagen) and promote angiogenesis; and transforming growth

factor (TGF), which stimulates keratinocytes. This step marks the transition into the process of tissue reconstruction, i.e., the proliferative phase.

[0054] The second stage of wound healing is the proliferative phase. Epithelialization, angiogenesis, granulation tissue formation, and collagen deposition are the principal steps in this anabolic portion of wound healing. Epithelialization occurs early in wound repair. At the edges of wounds, epidermis immediately begins thickening. Marginal basal cells begin to migrate across the wound along fibrin strands stopping when they contact each other (contact inhibition). Within the first 48 hours after injury, the entire wound is epithelialized. Layering of epithelialization is re-established. The depths of the wound at this point contain inflammatory cells and fibrin strands. Aging effects are important in wound healing as many, if not most, problem wounds occur in an older population. For example, cells from older patients are less likely to proliferate and have shorter life spans and cells from older patients are less responsive to cytokines.

[0055] Heart disease can be caused by a partial vascular occlusion of the blood vessels that supply the heart, which is preceded by intimal smooth muscle cell hyperplasia. The underlying cause of the intimal smooth muscle cell hyperplasia is vascular smooth muscle injury and disruption of the integrity of the endothelial lining. Intimal thickening following arterial injury can be divided into three sequential steps: 1) initiation of smooth muscle cell proliferation following vascular injury, 2) smooth muscle cell migration to the intima, and 3) further proliferation of smooth muscle cells in the intima with deposition of matrix. Investigations of the pathogenesis of intimal thickening have shown that, following arterial injury, platelets, endothelial cells, macrophages and smooth muscle cells release paracrine and autocrine growth factors (such as platelet derived growth factor, epidermal growth factor, insulin-like growth factor, and transforming growth factor) and cytokines that result in the smooth muscle cell proliferation and migration. T-cells and macrophages also migrate into the neointima. This cascade of events is not limited to arterial injury, but also occurs following injury to veins and arterioles.

[0056] Chronic inflammation, or granulomatous inflammation, can cause further complications during the healing of vascular injury. Granulomas are aggregates of particular types of chronic inflammatory cells which form nodules in the millimeter size range. Granulomas may be confluent, forming larger areas. Essential components of a granuloma

are collections of modified macrophages, termed epithelioid cells, usually with a surrounding zone of lymphocytes. Epithelioid cells are so named by tradition because of their histological resemblance to epithelial cells, but are not in fact epithelial; they are derived from blood monocytes, like all macrophages. Epithelioid cells are less phagocytic than other macrophages and appear to be modified for secretory functions. The full extent of their functions is still unclear. Macrophages in granulomas are commonly further modified to form multinucleate giant cells. These arise by fusion of epithelioid macrophages without nuclear or cellular division forming huge single cells which may contain dozens of nuclei. In some circumstances the nuclei are arranged round the periphery of the cell, termed a Langhans-type giant cell; in other circumstances the nuclei are randomly scattered throughout the cytoplasm (i.e., the foreign body type of giant cell which is formed in response to the presence of other indigestible foreign material in the tissue). Areas of granulomatous inflammation commonly undergo necrosis.

[0057] Formation of granulomatous inflammation seems to require the presence of indigestible foreign material (derived from bacteria or other sources) and/or a cell-mediated immune reaction against the injurious agent (type IV hypersensitivity reaction).

[0058] One aspect of the barrier layer 10 mentioned above is that it has modulated healing and adhesion-limiting characteristics or properties. By adhesion-limiting, what is meant is a characteristic whereby the incidence, extent, and severity of postoperative adhesions induced by trauma, desiccational air injury, blunt dissection, or other lacerations or tissue injuries, between different tissue structures and organs and medical devices, is reduced (or changed). The adhesion-limiting characteristic of the present invention results from the bio-absorbable and non-polymeric materials used to form the barrier layer 10 surfaces.

[0059] More specifically, the barrier layer 10 provides a lubricious and/or physical non-adhesive surface against adhesion prone tissue. The barrier layer 10 itself, in its partially or substantially cured configuration, can provide a physical adhesion-limiting barrier between two sections of tissue, or the barrier layer 10 can form a modulated healing surface on a medical device, such as the mesh 40. The use of the naturally occurring oil, such as fish oil, either in its native state or when processed into a cross-linked gel or film coating provides an unexpected gliding surface against normally tacky moist tissue, which helps to reduce

localized tissue abrasion injury and foreign body reaction. With less mechanical injury, there is less of an injury-induced inflammatory response, and less proliferative cell remodeling. The biological oil barrier created by the fatty acid oil derived barrier layer 10 likewise provides anti-inflammatory and less tissue stimulating or biologically reactive properties, thus further reducing the occurrence of inflammatory response and adhesion related events due to inflammation. The surface of the barrier layer 10 provides the modulated healing and mechanical adhesion-limiting characteristics. One of ordinary skill in the art will appreciate that different oil chemistry makeup, ingredients, and blends will have different healthier stimulus, adhesive limited effects, or cellular response reaction properties. The fatty acids used to form the oils into the gel or film can be modified to be more liquefied, emulsified, softer, more rigid, or more gel-like, solid, or waxy, as desired. Accordingly, the degree of modulated healing response and/or adhesive limiting and tissue reactive properties offered by the barrier layer 10 can vary by modifying either the physical properties and/or chemical properties of the fatty acid containing oil. The modification of the oils from a more liquid physical state to a more gel-like or solid, but still flexible, physical state is further implemented through the curing process. As the oils are cured, especially in the case of fatty acid-based oils such as fish oil, reversible cross-links form creating a gel. As the curing process is performed over increasing time durations and/or increasing temperature or intensity conditions, more cross-links form transitioning the gel from a relatively wet liquid gel to a relatively solid-like, but still flexible, dry to the touch gel structure.

[0060] Another aspect of the present invention is that the barrier layer 10 can be formed of the bio-absorbable material, such as naturally occurring fish oil, in accordance with the example embodiment described herein. The bio-absorbable properties of the naturally occurring oil enable the barrier layer 10 to be absorbed slowly by the ingestion of the fatty acid components by cells of the body tissue (i.e., bio-absorbable). In example embodiments of the present invention, the bio-absorbable barrier layer contains lipids, many of which originate as triglycerides. It has previously been demonstrated that triglyceride byproducts, such as partially hydrolyzed triglycerides and fatty acid molecules can integrate into cellular membranes and enhance the solubility of drugs into the cell. Whole triglycerides are known not to enhance cellular uptake as well as partially hydrolyzed triglyceride, because it is difficult for whole triglycerides to cross cell membranes due to their relatively larger molecular size. Other naturally occurring and synthetic oils, such as vitamin E compounds,

can also integrate into cellular membranes resulting in decreased membrane fluidity and cellular uptake.

[0061] Compounds that move too rapidly through a tissue may not be effective in providing a sufficiently concentrated dose in a region of interest. Conversely, compounds that do not migrate in a tissue may never reach the region of interest. Cellular uptake enhancers such as fatty acids and cellular uptake inhibitors such as alpha and gamma-tocopherols can be used alone or in combination to provide an effective transport of a given compound to a given cell target, region, or specific tissue location. Both fatty acids and alpha and gamma-tocopherols can be incorporated into the barrier layer of the present invention described herein. Accordingly, fatty acids and alpha and gamma-tocopherols can be combined in differing amounts and ratios to contribute to a barrier layer in a manner that provides control over the cellular uptake characteristics of the barrier layer and any therapeutic agents mixed therein.

[0062] For example, the type, blend, or amount of alpha and gamma-tocopherols can be varied in the barrier layer. Alpha and gamma-tocopherols are known to slow autoxidation in fish oil by reducing hydro peroxide formation, which results in a decrease in the amount of cross-linking in cured fish oil. In addition alpha and gamma-tocopherols can be used to increase solubility of drugs in the fish oil forming the barrier layer. Thus, varying the amount of alpha and gamma-tocopherols present in the barrier layer can impact the resulting formation. Alpha and gamma-tocopherols have been determined experimentally to provide a synergistic protective effect to therapeutic drugs and compounds during curing, which increases the resulting drug load in the barrier layer after curing. Furthermore, with certain therapeutic drugs, the increase of alpha and gamma-tocopherols in combination with fatty acids in the barrier layer serves to slow and extend the rate of drug release due to the increased solubility of the drug in the alpha and gamma-tocopherols component of the barrier layer. This reflects the cellular uptake inhibitor functionality of alpha and gamma-tocopherol compounds, in that the localized delivery and cellular uptake of the drug can be further modulated or controlled, slowed, and extended over time during barrier layer surface absorption by the localized tissue.

[0063] It should further be emphasized that the bio-absorbable nature of the barrier layer results in the barrier layer 10 being completely absorbed through cell mediated fatty acid

metabolic pathway over time by the localized cells in contact with the barrier layer. There are no known substances in the barrier layer surfaces, or break down byproducts of the barrier layer, that induce an inflammatory response during the naturally occurring fatty acid absorption process. The barrier layer 10 is generally composed of, or derived from, omega-3 fatty acids bound to triglycerides, potentially also including a mixture of free fatty acids and, depending upon the drug, options combinations with vitamin E (alpha and gamma-tocopherols). The triglycerides are broken down by lipases (enzymes) which result in free fatty acids that can then be transported across cell membranes. Subsequently, fatty acid metabolism by the cell occurs to metabolize any substances originating with the barrier layer. The bio-absorbable nature of the barrier layer of the present invention results in the barrier layer modulating healing and limiting adhesion formation while being completely absorbed over time, ultimately leaving only an underlying reinforced delivery or other medical device structure that is biocompatible. There is no known foreign body reaction or inflammatory response to the components forming the bio-absorbable barrier layer, or reinforced anchoring support elements.

[0064] Although the barrier layer of the present invention is bio-absorbable to the extent that the barrier layer 10 experiences uptake and consumption into or through localized body tissues, in the specific embodiment described herein formed using naturally occurring oils, or synthetic equivalents, the exemplar oils are also lipid based oils. The lipid content of the oils provides a highly bio-absorbable barrier layer 10. More specifically, there is a phospholipids layer in each cell of the body tissue. The fish oil, and equivalent oils, contain lipids as well. There is a lipophilic action that results where the lipids are attracted by each other in an effort to escape the aqueous environment surrounding the lipids.

[0065] A further aspect of the barrier layer 10 is that the specific type of oil can be varied, and can contain elements beneficial to modulating healing. The barrier layer 10 also breaks down during the absorption process into smaller fatty acid components, which can contribute to the localized tissue healing process involving cellular in-growth and remodeling of the barrier layer device. The addition of therapeutic agents to the barrier layer 10 component specifically for a localized drug delivery indication can be further utilized for additional beneficial biological effects, such as pain stimulation reduction or reduction in bacterial colonization, bio film formulation and adhesion, or localized infection minimization.

[0066] As described previously, the process of modulated healing and cellular remodeling with barrier layer implants with reinforced anchoring support involves different cascades or sequences of naturally occurring tissue repair in response to localized tissue injury, and it encompasses many different biologic processes, including epithelial growth, inhibition, proliferation and/or differentiation, connective fibrous tissue production and function, angiogenesis, and several stages of acute and/or chronic inflammation. The reversibly cross-linked gel of the barrier layer has been shown experimentally in animal models not to produce or induce a protracted inflammatory response and to delay healing or formation of connective fibrous tissue following tissue injury. Likewise, the reversibly cross-linked gel of the barrier layer has exhibited a complimentary or synergistic modulated healing effect, which results in a less dense, but uniformly confluent cellular overgrowth of a porous implanted mesh structure with little to no fibrous capsule formation, which is otherwise commonly seen with conventional permanent mechanical barrier devices. Accordingly, the cross-linked gel of the barrier layer 10 provides an excellent absorbable cellular interface suitable for use with a surgical implant with reinforced anchoring support.

[0067] Another aspect of the barrier layer 10 mentioned above is that the barrier layer 10 can contain therapeutic agents for local delivery to the body tissue in contact with the device. Therapeutic agents have been delivered to a localized target location within a human utilizing a number of different methods in the past. For example, agents may be delivered nasally, transdermally, intravenously, orally, or via other conventional systemic delivery methods. Local therapeutic delivery from a biological oil barrier layer device can be made to vary the therapeutic agent release rate (i.e., quick release or slow release) as part of the desired modulated healing effect of the barrier film surfaces.

[0068] As utilized herein, the phrase "therapeutic agent(s)" refers to a number of different drugs or biologically active agents available, as well as future agents that may be beneficial for use with the barrier layer of the present invention. Therapeutic agents can be added to the barrier layer 10, and/or the medical device in combination with the barrier layer 10 as discussed herein. The therapeutic agent component can take a number of different forms including additional modulated healing agents, adhesion-limiting agents, anti-oxidants, anti-inflammatory agents, anti-coagulant agents, thrombolysing agents, drugs to alter lipid metabolism, anti-proliferating agents, anti-neoplastics, tissue growth stimulants, functional protein/factor delivery agents, bactericidal agents, anti-biofilm adhesion agents, anti-

infective agents, imaging agents, anesthetic agents, therapeutic agents, tissue absorption enhancers, antibiotics, germicides, anti-fungal agents, anti-septics, analgesics, prodrugs, and any additional desired therapeutic agents such as those listed in Table 1 below.

Table #1

CLASS	EXAMPLES
Antioxidants	Alpha and gamma-tocopherols, fatty acids, lazaroid, probucol, phenolic antioxidant, resveretrol, AGI-1067, vitamin E
Antihypertensive Agents	Diltiazem, nifedipine, verapamil
Antiinflammatory Agents	Glucocorticoids (e.g. dexamethazone, methylprednisolone), fatty acids, leflunomide, NSAIDS, ibuprofen, acetaminophen, hydrocortizone acetate, hydrocortizone sodium phosphate, macrophage-targeted bisphosphonates
Growth Factor Antagonists	Angiopeptin, trapidil, suramin
Antiplatelet Agents	Aspirin, fatty acids, dipyridamole, ticlopidine, clopidogrel, GP IIb/IIIa inhibitors, abciximab
Anticoagulant Agents	Bivalirudin, heparin (low molecular weight and unfractionated), wafarin, hirudin, enoxaparin, citrate
Thrombolytic Agents	Alteplase, reteplase, streptase, urokinase, TPA, citrate, abciximab, viperinex
Drugs to Alter Lipid Metabolism (e.g. statins)	Fluvastatin, fatty acids, alpha and gamma-tocopherols, fish oil, colestipol, lovastatin, atorvastatin, amlopidine
ACE Inhibitors	Elanapril, fosinopril, cilazapril
Antihypertensive Agents	Prazosin, doxazosin
Antiproliferatives and Antineoplastics	Cyclosporine, cochicine, mitomycin C, sirolimus micophenonic acid, rapamycin, everolimus, tacrolimus, paclitaxel, QP-2, actinomycin, estradiols, dexamethasone, methatrexate, fatty acids, cilostazol, prednisone, cyclosporine, doxorubicin, ranpirnas, troglitzon, valsarten, pemirolast, C-MYC antisense, angiopeptin, vincristine, PCNA ribozyme, 2-chloro-deoxyadenosine
Tissue growth stimulants	Bone morphogeneic protein, fibroblast growth factor
Promotion of hollow organ occlusion or thrombosis	Alcohol, surgical sealant polymers, polyvinyl particles, 2-octyl cyanoacrylate, hydrogels, collagen, liposomes, polymer surgical adhesives
Functional Protein/Factor	Insulin, human growth hormone, estradiols, nitric oxide,

delivery	endothelial progenitor cell antibodies
Second messenger targeting	Protein kinase inhibitors
Angiogenic	Angiopoetin, VEGF
Anti-Angiogenic	Endostatin
Inhibition of Protein Synthesis/ECM formation	Halofuginone, prolyl hydroxylase inhibitors, C-proteinase inhibitors
Antiinfective Agents	Penicillin, gentamycin, adriamycin, cefazolin, amikacin, ceftazidime, tobramycin, levofloxacin, silver, copper, hydroxyapatite, vancomycin, ciprofloxacin, rifampin, mupirocin, RIP, kanamycin, brominated furonone, algae byproducts, bacitracin, oxacillin, nafcillin, floxacillin, clindamycin, cephradine, neomycin, methicillin, oxytetracycline hydrochloride, Selenium., sirolimus, rapamycin, minocycline, rifampin, cephalosporin
Gene Delivery	Genes for nitric oxide synthase, human growth hormone, antisense oligonucleotides
Local Tissue perfusion	Alcohol, H ₂ O, saline, fish oils, vegetable oils, liposomes, fatty acid derived from fish oils, vitamin E
Nitric oxide Donor Derivatives	NCX 4016 – nitric oxide donor derivative of aspirin, SNAP
Gases	Nitric oxide, compound solutions
Imaging Agents	Halogenated xanthenes, diatrizoate meglumine, diatrizoate sodium, MRI contrast agents, PET/CT contrast agents, ultrasound contrast agents
Anesthetic Agents	Lidocaine, benzocaine, bupivacaine, levobupivacaine, ropivacaine, xylocaine
Descaling Agents	Nitric acid, acetic acid, hypochlorite
Anti-Fibrotic Agents	Interferon gamma -1b, Interleukin - 10
Immunosuppressive/Immunomodulatory Agents	Cyclosporine, rapamycin, mycophenolate mofetil, leflunomide, tacrolimus, tranilast, interferon gamma-1b, mizoribine
Chemotherapeutic Agents	Doxorubicin, paclitaxel, tacrolimus, sirolimus, fludarabine, ranpirinase, cyclosporine
Tissue Absorption Enhancers	Fish oil, squid oil, omega 3 fatty acids, vegetable oils, lipophilic and hydrophilic solutions suitable for enhancing medication tissue absorption, distribution and permeation
Adhesion-limiting Agents	Hyaluronic acid, fatty acids, fish oil, vitamin E, human plasma derived surgical sealants, biodegradable hydrogels, surgical adhesives, and agents comprised of hyaluronate and carboxymethylcellulose that are combined with dimethylaminopropyl, ethylcarbodiimide, hydrochloride,

	PLA, PLGA
Ribonucleases	Ranpirnase
Germicides	Betadine, iodine, silver acetate, silver nitrate, furan derivatives, nitrofurazone, benzalkonium chloride, benzoic acid, salicylic acid, hypochlorites, peroxides, thiosulfates, salicylanilide
Antiseptics	Selenium, hydrogen peroxide
Analgesics	Bupivacaine, naproxen, ibuprofen, acetylsalicylic acid, levobupivacaine, ropivacaine, xylocaine

[0069] Some specific examples of therapeutic agents useful in modulating or controlling localized tissue trauma response to cellular re-modeling with medical implants with barrier layers and/or modulated healing, and/or cellular proliferation involved in healing response include, modulated healing or anti-proliferating compounds including cerivastatin, cilostazol, fluvastatin, lovastatin, paclitaxel, pravastatin, m-Tor effecting compounds such as sirolimus, including, rapamycin, a rapamycin carbohydrate derivative (for example, as described in US Patent Application Publication 2004/0235762), a rapamycin derivative (for example, as described in US Patent No. 6,200,985), pro-drugs derived from rapamycin, analogs of rapamycin, including, everolimus, seco-rapamycin, seco-everolimus, and simvastatin. With systemic administration of such compounds orally, intravenously, or otherwise, the compounds are generally diluted throughout the body without specific localized delivery effect. There are drawbacks to a systemic delivery of a therapeutic agent, one of which is uncontrolled distribution that can occur when the therapeutic agent travels to all portions of the patient's body and creates undesired or unexpected effects at areas not targeted for treatment by the therapeutic agent. Furthermore, large doses of the therapeutic agent only amplify the undesired effects at non-target areas. As a result, the amount of therapeutic agent that results in application to a specific targeted location in a patient may have to be reduced when administered systemically to reduce complications from toxicity resulting from a higher systemic dosing of the therapeutic agent.

[0070] Accordingly, an alternative to the systemic administration of a therapeutic agent is the use of a targeted local therapeutic agent delivery approach. With local delivery of a therapeutic agent, the therapeutic agent is administered using a medical device or apparatus (such as the barrier device of the present invention), directly by hand, or sprayed on the tissue, at a selected targeted tissue location of the patient that requires treatment. The

therapeutic agent emits, or is otherwise delivered, from the medical device apparatus, and/or carrier (such as the barrier layer), and is applied to the targeted tissue location. The local delivery of a therapeutic agent enables a more concentrated and higher quantity of therapeutic agent to be delivered directly at the location of the implanted device, without having broader systemic distribution and potential remote target side effects.

[0071] Targeted local therapeutic agent delivery using a medical device with one or more barrier layers can be further broken into two categories, namely, short term and long term bioavailability to localized tissue ranging generally within a matter of seconds or minutes to a few days or weeks to a number of months. Conventionally, to achieve the long term bioavailability and delivery of a therapeutic agent to localized tissue, the therapeutic agent must be combined with a delivery agent, or otherwise formed with a physical impediment as a part of the medical device, to maximize absorption transfer of the therapeutic agent over an extended period of time while being absorbed by the local tissue.

[0072] Prior attempts to create surgically applied films and drug delivery platforms, such as in the field of soft tissue reinforcement, repair, or adhesion prevention, involving any soft tissue surgical intervention, make use of high molecular weight synthetic polymer base materials, including bio-degradable and bio-erodable polymer films, non-absorbable polymer films, polymer gels and/or polymer coatings, to deliver therapeutic agents. Essentially, the polymer complexes in the platform release the drug or agent by allowing the drug to escape out from the polymer as it begins to dissolve at a predetermined rate once implanted at a location within the patient. Regardless of how beneficial to the local targeted tissue, most known polymer delivery materials release the therapeutic agent based release properties of the bulk polymer to elute the therapeutic agent or compound into adjacent or localized tissue and interstitial body fluids. Accordingly, the effect of the therapeutic agent is substantially local at the surface of the tissue making contact with the medical device having the coating. In some instances the effect of the therapeutic agent is further localized to the specific locations of, for example, stent struts or mesh that are anchored against the tissue location being treated. These prior approaches can create two different but undesirable local effects. One effect is the potential for an undesirable large quantity of drug into interstitial body fluids effecting bio-availability or cellular uptake of the drug, causing a localized or toxic effect. A second effect is an extended foreign body reaction to the carrier

polymer after the therapeutic compound has been exhausted out of the polymer changing its local biochemical condition to adjacent tissue.

[0073] The barrier layer 10 of the present barrier device invention, however, makes use of biocompatible oils to form a non-polymeric bio-absorbable oil based therapeutic agent delivery platform, if desired. Furthermore, the barrier layer 10 can be formed in a manner that creates the potential for controlled long term release of a therapeutic agent, while still maintaining the modulated healing, adhesion-limiting, and/or anti-inflammatory benefits of the oil component of the barrier layer 10.

[0074] More specifically, it is known that oil that is oxygenated becomes a waxy solid. Attempts have been made to convert the polyunsaturated oils into a wax or solid to allow the oil to adhere to a device for a longer period of time. One such approach applies the oil to the medical device and allows the oil to dry.

[0075] With the present invention, and in the field of soft tissue reinforcement applications, and in part because of the lipophilic mechanism enabled by the bio-absorbable lipid based barrier layer 10 of the present invention, the uptake of the therapeutic agent is facilitated by the delivery of the therapeutic agent to the cell membrane by the bio-absorbable barrier layer 10, and not by drug release or elution out from the physical matrix used to form the barrier layer surfaces. Further, the therapeutic agent is not freely released into interstitial body fluids that are subject to systemic circulation, but rather, is delivered deployed locally into the cells and tissue in contact with the barrier layer surfaces. In prior configurations using polymer based coatings, the once immobilized drugs or agents are released out from the polymer structure at a rate regardless of the reaction or need for the drug on the part of the cells receiving the drug.

[0076] In addition, the bio-absorbable oil used to form the barrier layer 10 is a naturally occurring oil, or synthetic equivalent, containing the omega-3 fatty acids (including DHA and EPA), and the process used for forming the barrier layer 10 of the present invention can be tailored to avoid causing detrimental effects to the beneficial properties of the omega-3 fatty acids, or at least effects too detrimental to have any lasting effect. Certain properties of the fatty acids may lose their effectiveness during curing, however other desired properties

are maintained. Example embodiments illustrating the formation and different configurations of the barrier layer 10 are provided herein.

[0077] To summarize, the barrier layer 10 of the present invention serves as a non-polymeric biological oil barrier layer and can also serve as a therapeutically loadable physical barrier layer to modulate healing and/or limit adhesion formation to the device when sufficiently cured, altered chemically, and structured into a barrier layer. In accordance with the example embodiments described herein, the barrier layer is formed of a non-polymeric cross-linked gel, dry to the touch, which can be derived from fatty acid compounds. The fatty acids include omega-3 fatty acids when the oil utilized to form the barrier layer is fish oil or an analog or derivative thereof. As liquid pharmaceutical grade fish oil is heated, autoxidation occurs with the absorption of oxygen into the fish oil to create hydroperoxides in an amount dependent upon the amount of unsaturated (C=C) sites in the fish oil. However, the (C=C) bonds are not consumed in the initial reaction. Concurrent with the formation of hydroperoxides is the isomerization of (C=C) double bonds from cis to trans in addition to double bond conjugation. It has been demonstrated that hydroperoxide formation increases with temperature. Heating of the fish oil allows for cross-linking between the fish oil unsaturated chains using a combination of peroxide (C-O-O-C), ether (C-O-C), and hydrocarbon (C-C) bridges. The formation of the cross-links results in gelation of the barrier layer after the (C=C) bonds have substantially isomerized into the trans configuration. The (C=C) bonds can also form C-C cross-linking bridges in the glyceride hydrocarbon chains using a Diels-Alder Reaction. In addition to solidifying the barrier layer through cross-linking, both the hydroperoxide and (C=C) bonds can undergo secondary reactions converting them into lower molecular weight secondary oxidation byproducts including aldehydes, ketones, alcohols, fatty acids, esters, lactones, ethers, and hydrocarbons.

[0078] Accordingly, the barrier layer non-polymeric cross-linked gel derived from fatty acid compounds, such as those derived from fish oil, include a reversible cross-linked structure of triglyceride and fatty acid molecules in addition to free and bound glycerol, monoglyceride, diglyceride, and triglyceride, fatty acid, anhydride, lactone, aliphatic peroxide, aldehyde, and ketone molecules. There are a substantial amount of ester bonds remaining after curing in addition to peroxide linkages forming the majority of the cross-links in the gel. The barrier layer degrades into fatty acid, short and long chain alcohol, and

glyceride molecules, which are all non-inflammatory and likewise consumable by cells in the soft tissue to which the barrier layer is applied. Thus, the barrier layer is bio-absorbable.

[0079] **FIGS. 2A, 2B, and 2C** illustrate side views of multiple different embodiments of the barrier layer 10 when cured into a flexible cross-linked gel. In **FIG. 2A**, a barrier layer 10A is shown having two tiers, a first tier 20 and a second tier 22. The first tier 20 and the second tier 22 as shown are formed of different materials. The different materials can be, for example, different forms of fish oil, different naturally occurring oils or biocompatible oils other than fish oil, or therapeutic components as will be discussed later herein. The different materials bind together to form the barrier layer 10A.

[0080] **FIG. 2B** shows a barrier layer 10B having a first tier 24, a second tier 26, and a third tier 28. In the illustrative embodiment shown, each of the tiers 24, 26, and 28 is formed of the same material. The plurality of tiers indicates the ability to create a thicker barrier layer 10 if desired. The greater the number of tiers, the thicker the resulting film. The thickness of the barrier layer 10 can have an effect on the overall strength and durability of the barrier layer 10. A thicker film can be made to be generally stronger and more durable, or can be made to be weaker and less durable, depending on the clinical application. In addition, the thickness of the barrier layer 10 can also affect the duration of time that the barrier layer 10 lasts and provides modulated healing or limited adhesion after implantation. A thicker barrier layer 10 provides more material to be absorbed by the body, and thus will last longer than a thinner barrier layer 10 of the same chemical makeup, which ultimately influences the implementation of the modulated healing. One of ordinary skill in the art will appreciate that the thickness of the barrier layer 10 can vary both by varying the thickness of each tier 24, 26, and 28, and by varying the number of tiers 24, 26, and 28. Accordingly, the present invention is not limited to the particular layer combinations illustrated.

[0081] **FIG. 2C** shows another barrier layer 10C, having four tiers, a first tier 30, a second tier 32, a third tier 34, and a fourth tier 36. In this example embodiment, the first tier 30 and the third tier 34 are formed of the same material, while the second tier 32 and the fourth tier 36 are formed of a material different from each other and different from that of the first tier 30 and the third tier 34. Accordingly, this embodiment illustrates the ability to change the number of tiers, as well as the material used to form each of the tiers 30, 32, 34, and 36. Again, the different materials can be derived from different forms of fish oil,

different naturally occurring oils other than fish oil, or therapeutic components as will be discussed later herein.

[0082] **FIGS. 3A through 3F** show additional embodiments or configurations of the barrier layer 10. The embodiments include barrier layer 10D in a circular configuration, barrier layer 10E in an oval configuration, barrier layer 10F in a U-bend configuration, barrier layer 10G in a square configuration having a circular aperture, barrier layer 10H in a wave configuration, and barrier layer 10I in an irregular shape configuration. Each of the configurations of the barrier layer 10D through 10I represent different types of configurations. The configurations illustrated are by no means the only possible configurations for the barrier layer 10. One of ordinary skill in the art will appreciate that the specific shape or configuration of the barrier layer 10 can vary as desired. A more prevalent configuration is the rectangular or oblong configuration of **FIG. 1**. However, **FIGS. 3A through 3F** illustrate a number of different alternative embodiments, and indicate some of the many possible configurations.

[0083] **FIG. 4** is a flowchart illustrating one example method for the formation of the barrier layer 10. A surface is provided having a release agent (step 100). The surface can be prepared by the application of the release agent, or the release agent can be pre-existing. The release agent can be a number of different solutions, including for example, polyvinyl alcohol (PVA). The release agent can be applied in a number of different ways as well, including but not limited to casting, impregnating, spraying, dipping, coating, painting, and the like. It should be noted that the release agent can be applied optionally to the surface immediately prior to the remaining steps or well in advance of the remaining steps, so long as when the remaining steps are executed there is a release agent on the surface. It should further be noted that the need of an optional release agent can be eliminated if the surface itself has inherent characteristics similar to one having a release agent. Specifically, the surface can instead have a Teflon® coating, or other similar more permanent release surface. In such an instance, there is no need for a release agent, or subsequent removal of the release agent from the barrier layer formed.

[0084] An oil component is applied to the surface on top of the release agent (step 102). As noted previously, the oil component can be a naturally occurring oil, such as fish oil, cod liver oil, cranberry oil, or other oils having desired characteristics. In addition, the oil

component can be an oil composition, meaning a composition containing oil in addition to other substances. For example, the oil composition can be formed of the oil component in addition to a solvent and/or a preservative. Solvents can include a number of different alternatives, including ethanol or N-Methyl-2-Pyrrolidone (NMP). The preservative can also include a number of different alternatives, including vitamin E. One of ordinary skill in the art will appreciate that there are a number of different solvents and preservatives available for use with the oil component to form the oil composition, and as such the present invention is not limited to only those listed in the examples herein. The solvent can be useful to alter the physical properties of the oil, as well as prepare the oil for combination with a therapeutic agent as described below. The preservative can also be useful in altering the physical properties of the oil component, as well as protecting some of the beneficial properties of the oil component during certain curing processes. Such beneficial properties include the healing and anti-inflammatory characteristics previously mentioned.

[0085] The oil component can be combined with one or more therapeutic agents to form an oil composition. Thus, if the added therapeutic benefit of a particular therapeutic agent or agents is desired, the therapeutic agent(s) can be added to the oil component prior to application to the surface, along with the oil component during application to the surface (including mixing with the oil component prior to application), or after the oil component has been applied (step 104). The different alternatives for adding the therapeutic agent(s) are determined in part based on the desired effect and in part on the particular therapeutic agent(s) being added. Some therapeutic agents may have reduced effect if present during a subsequent curing step. Some therapeutic agents may be more useful intermixed with the oil component to extend the release period, or applied to the surface of the oil component, resulting in a faster release because of increased exposure. One of ordinary skill in the art will appreciate that a number of different factors, such as those listed above in addition to others, can influence when in the process the therapeutic agent is added to the oil component, or the barrier layer 10. Accordingly, the present invention is not limited to the specific combinations described, but is intended to anticipate all such possible variations for adding the therapeutic agent(s).

[0086] For example, if 80% of a therapeutic agent is rendered ineffective during curing, the remaining 20% of therapeutic agent, combined with and delivered by the barrier can be efficacious in treating a medical disorder, and in some cases have a relatively greater

therapeutic effect than the same quantity of agent delivered with a polymeric or other type of coating or barrier. This result can be modified with the variance of alpha and gamma-tocopherols to protect the therapeutic agent during the curing process, and then slow and extend the delivery of the therapeutic agent during absorption of the barrier layer into the tissue.

[0087] The oil component (or composition if mixed with other substances) is then hardened into the barrier layer 10 (step 106). The step of hardening can include hardening, or curing, such as by introduction of UV light, heat, oxygen or other reactive gases, chemical curing, or other curing or hardening method. The purpose of the hardening or curing is to transform the more liquid consistency of the oil component or oil composition into a more solid film, while still maintaining sufficient flexibility to allow bending and wrapping of the film as desired.

[0088] After the barrier layer 10 has formed, another determination is made as to whether therapeutic agents should be applied to the film. If desired, the therapeutic agent(s) is added to the barrier layer 10 (step 108). Subsequently, the barrier layer 10 is removed from the surface (step 110). Once again, there is opportunity to apply a therapeutic agent(s) to the barrier layer 10 on one or both sides of the barrier layer 10. If such therapeutic agent(s) is desired, the therapeutic agent(s) is applied (step 112). The additional therapeutic agent can also be applied in the form of a non-cured or minimally cured oil, such as fish oil. The oil can likewise include other therapeutic agents mixed therewith. The resulting structure of such an application forms the underlying barrier layer 10 that is cured to form the film, with a top coating of oil and potentially additional therapeutic agent layered on top. This structure enables the provision of a short term release of therapeutic from the oil top layer combined with a longer term release from the cured film, which takes more time to degrade.

[0089] After application of the therapeutic agent(s), or after the barrier layer 10 is removed from the surface, the barrier layer 10 is sterilized. The sterilization process can be implemented in a number of different ways. For example, sterilization can be implemented utilizing ethylene oxide, gamma radiation, E beam, steam, gas plasma, or vaporized hydrogen peroxide (VHP). One of ordinary skill in the art will appreciate that other sterilization processes can also be applied, and that those listed herein are merely examples

of sterilization processes that result in a sterilization of the barrier layer 10, preferably without having a detrimental effect on the barrier layer.

[0090] It should be noted that the oil component or oil composition can be added multiple times to create multiple tiers in forming the barrier layer 10. For example, if a thicker barrier layer 10 is desired, additional tiers of the oil component or oil composition can be added after steps 100, 104, 106, 108, 110, or 112. Different variations relating to when the oil is hardened and when other substances are added to the oil are possible in a number of different process configurations. Accordingly, the present invention is not limited to the specific sequence illustrated. Rather, different combinations of the basic steps illustrated are anticipated by the present invention.

[0091] **FIGS. 5A** and **5B** illustrate the barrier layer 10 and a medical device in the form of a mesh 40, which together form a barrier device 11. In **FIG. 5A**, the barrier layer 10 and mesh 40 are shown in exploded view, while **FIG. 5B** shows the barrier layer 10 coupled with the mesh 40 to form the barrier device 11. The mesh 40 is merely one example medical device that can be entirely impregnated or 100% coupled with the barrier layer 10. In the instance of the mesh 40, it can be useful to have one side of the fully impregnated mesh support to be made having an irregular or non-smooth surface to encourage faster or less delayed tissue in-growth, and the other side of the mesh with a smoother barrier layer 10. The smoother side of the barrier layer 10 can exhibit a more uniform tissue contacting support for gliding on tissue without dragging or pulling on the underlying tissue during installation, a smooth surface which limits the rate and/or attachment on adjacent tissue, a smooth surface which restricts the rate of in-growth, and provides improved adhesion-limiting, anti-inflammatory, and/or non-inflammatory surface properties. The coupling of the barrier layer 10 with the mesh 40 achieves such a device.

[0092] As understood by one of ordinary skill in the art, the properties of the mesh 40 and the barrier layer 10 can vary. There may be a requirement for the mesh 40 to have one side, or a portion of a side, that has adhesion-limiting properties for a period of several days. There may be a requirement for the mesh 40 to have one side, or a portion of a side, that has an irregular, non-smooth or thin barrier layer with mechanical or biochemical properties that last for a period of several hours to several days. As a further alternative, multiple locations on the mesh 40 may be required to have irregular, non-smooth, or roughened properties. As

such, the barrier layer 10 can be applied to all sides, or portions of sides, or portions of one side of the mesh 40, whether it results in an irregular, smooth, bumpy, roughened, uniform, non-uniform, thickened, thin, or varying layer, or a layer that coats individual strands of a mesh structure, leaving the interstitial spaces open.

[0093] In addition, the requirement may be for the barrier layer adhesion-limiting, or reduced adhesion properties to last several weeks, several months, or even longer. Accordingly, the rate of degradation can also be varied by changing such properties as amount of readily reversible versus slow to reverse cross-linking, thickness, and existence of additives, such as vitamin E compounds (alpha and gamma-tocopherol) to achieve longer or shorter term adhesion-limiting and/or modulated healing properties. In addition, there may be a desire to include a therapeutic agent to further reduce inflammation, signaling via the mTOR pathway, or in selected clinical indications enhance cellular proliferation or speed up healing via the natural antigenic responding or inflammatory pathways, or to provide reduced localized pain stimulation at the site of the medical device fixation, or anchoring means, or to provide localized antibiotic delivery to reduce biofilm adhesion and biofilm formation, or anti-infective agent therapy, or other therapeutic measures, in combination with the use of the mesh 40. Accordingly, the therapeutic agent(s) can be added to the barrier layer 10, or coated thereon, or made mechanically different from location to location, to achieve the desired controlled release of the therapeutic agent after implantation. As previously described, combinations of various cure rates and methods used to apply the biological oils can be used, including for example one or more top coatings placed onto the barrier layer with lesser cured or non-cured oils with and/or without therapeutic agents made part of the barrier layer 10.

[0094] The particular properties or characteristics of the mesh 40 are determined based on the desired use of the mesh 40. A common implementation is for the mesh 40 to be formed of a bio-compatible material, such as polypropylene, however other bio-compatible materials can be utilized, such as a porous mesh or porous polymer film formed of the same or similar substance as the barrier layer 10 (i.e., oil based).

[0095] **FIG. 6** is a flowchart illustrating one example method for forming the medical device (i.e., mesh 40) and barrier layer 10 combination. The medical device is provided (step 150). The medical device can be, for example, the mesh 40.

[0096] A determination is made as to whether a release agent should be added to the medical device to aid in removing the device from its location (e.g., on a surface) after combination with the barrier layer 10. If a release agent is required, the release agent is applied to the medical device (step 152). An example release agent for such an application is polyvinyl alcohol.

[0097] The medical device is then combined with the barrier layer 10 (step 154). Depending on the particular medical device, the combination with the barrier layer 10 can be implemented more efficiently by either applying the barrier layer 10 to the medical device, or placing the medical device on the barrier layer 10. For example, in the case of the mesh 40, the mesh 40 can be placed on top of the barrier layer 10, or the barrier layer 10 can be placed on top of the mesh 40.

[0098] The medical device and the barrier layer are then cured to create a bond (step 156). The curing process can be one of several known processes, including but not limited to applying heat, or UV light, or chemical curing, to cure the barrier layer. In the instance of the curing occurring with the liquid form of the barrier layer that is poured over and/or through the mesh, the curing creates a coating in and around the mesh 40, encapsulating the mesh within the barrier layer 10. After curing, if there is any release agent present, the release agent is washed away using water, or some other washing agent (step 158).

[0099] **FIG. 7** is a flowchart illustrating another example method of forming a medical device with a barrier layer. A surface is prepared with a release agent, such as PVA (step 170), as needed. The medical device is placed on the surface (step 172). In the example embodiment, the medical device is the mesh 40. The oil component or oil composition is applied to the medical device (step 174). In the instance of the mesh 40, the oil component or oil composition is poured or sprayed onto the mesh 40. In such an embodiment the barrier layer 10 will fall substantially to a bottom side of the mesh 40 (due to gravitational pull), leaving a thinner coating or amount at a top side of the mesh 40, but still substantially encapsulating the mesh within the liquid of the barrier layer 10 material. Such a coating process provides for a barrier layer on all sides of the medical device (mesh 40). The combined oil component/composition and mesh 40 are then cured (step 176) using methods such as application of heat, UV light, oxygen and other reactive gases, chemical cross-linker, or hardening processes, to form the barrier layer in combination with the mesh 40. The

combined barrier layer and mesh are then removed from the surface (step 178) and the release agent is washed away (step 180).

[00100] As with the method of FIG. 6, if desired, a therapeutic agent can be added to the oil component or oil composition at any point along the process forming the combined barrier layer 10 and mesh 40, including being a component of the oil composition. As discussed previously, consideration must be given as to whether the therapeutic agent may be affected by the curing process, or other aspects of the process.

[00101] Furthermore, the formation of the oil composition can be done in accordance with different alternatives to the methods described. For example, prior to forming the barrier layer 10, a preservative and/or compatibilizer, such as Vitamin E can be mixed with the oil component to form the oil composition. A solvent can be mixed with a therapeutic agent, and then added to the oil to form the oil composition. The solvent can be chosen from a number of different alternatives, including ethanol or N-Methyl-2-Pyrrolidone (NMP). The solvent can later be removed with vacuum or heat.

[00102] In addition, it should again be noted that the oil component or oil composition can be added multiple times to create multiple tiers in forming the barrier layer 10. If a thicker barrier layer 10 is desired, additional tiers of the oil component or oil composition can be added after steps 174 and 176. Different variations relating to when the oil is hardened and when other substances are added to the oil are possible in a number of different process configurations. Accordingly, the present invention is not limited to the specific sequence illustrated. Rather, different combinations of the basic steps illustrated are anticipated by the present invention.

[00103] Depending on the type of therapeutic agent component added to the barrier layer 10, the resulting barrier layer 10 can maintain its bio-absorbable characteristics if the therapeutic agent component is also bio-absorbable.

[00104] The therapeutic agent component, as described herein, has some form of therapeutic or biological effect. The oil component or oil composition component can also have a therapeutic or biological effect. Specifically, the barrier layer 10 (and its oil constituents) enable the cells of body tissue of a patient to absorb the barrier layer 10 itself,

rather than breaking down the film and discharging by-products of the film for ultimate elimination by the patient's body.

[00105] As previously stated, and in accordance with embodiments of the present invention, the barrier layer 10 is formed of a biocompatible oil, or composition including a naturally occurring oil, such as fish oil, cod liver oil, cranberry oil, and the like, or a synthetic oil including at least the required fatty acids and lipids in accordance with characteristics of the natural oils. A characteristic of the biocompatible oil is that the oil includes lipids, which contributes to the lipophilic action described later herein, that is helpful in the delivery of therapeutic agents to the cells of the body tissue. In addition, the biocompatible oil can include the essential omega-3 fatty acids in accordance with several embodiments of the present invention.

[00106] **FIGS. 8A, 8B, and 8C** illustrate some of the other forms of medical devices mentioned above in combination with the barrier layer 10 of the present invention. **FIG. 8A** shows a graft 50 with the barrier layer 10 coupled or adhered thereto. **FIG. 8B** shows a catheter balloon 52 with the barrier layer 10 coupled or adhered thereto. **FIG. 8C** shows a stent 54 with the barrier layer 10 coupled or adhered thereto. Each of the medical devices illustrated, in addition to others not specifically illustrated or discussed, can be combined with the barrier layer 10 using the methods described herein, or variations thereof. Accordingly, the present invention is not limited to the example embodiments illustrated. Rather the embodiments illustrated are merely example implementations of the present invention.

[00107] In addition to the above-described configurations, the present invention can take the form of the barrier layer 10 formed with, or within, the medical device in the form of the mesh 40, with an anchoring support element 60, to form a reinforced barrier device 11' having a modulated healing barrier surface. In **FIGS. 9 and 10**, the barrier layer 10 and mesh 40 are shown with the barrier layer 10 coupled with the mesh 40. Again, the mesh 40 is merely one example medical device that can be coupled with the barrier layer 10. The mesh 40 can have one or more tissue contacting surfaces that exhibit a rougher surface to encourage tissue in-growth, and the opposite side of the mesh can have an adhesion-limiting, anti-inflammatory, and/or non-inflammatory surface or coating that is substantially smoother to prevent the mesh from injuring surrounding tissue or causing inflammation. The

smoother surfaces of the mesh 40 and barrier layer 10 combination act to delay healing, reduce adhesion formations, and are less disruptive, and more lubricious. It should additionally be noted that the mesh 40 and barrier layer 10 combination can further exhibit different surface topography, different surface gradients uniformity, and different levels of dryness, tackiness or smoothness properties. The barrier layer 10, in the example embodiment illustrated, is integrally coupled with the mesh 40 to the extent that the mesh 40 structure is fully enveloped or encapsulated within the barrier layer 10, and not merely coupled on one side of the mesh 40 with the barrier layer 10. As discussed below, this results in a thinner layer of the barrier layer 10 on a top side of the mesh 40 (as oriented during application of the barrier layer material) and a thicker layer of the barrier layer 10 occurring on a bottom side of the mesh 40; however the entirety of the mesh structure, if desired, is fully enveloped or encapsulated within a thin or thick layer of the barrier layer 10. The coupling of the barrier layer 10 with the mesh 40 achieves such a device.

[00108] The mesh 40 further includes the anchoring support element 60, which in the illustrative embodiment of the present figure is in the form of a frame of mesh that follows along the perimeter of the mesh 40. Thus, with a rectangular or oblong shaped mesh 40, the frame of the anchoring support element 60 is likewise rectangular or oblong in shape. One of ordinary skill in the art will appreciate that the shape of the anchoring support element 60 depends upon the shape of the underlying mesh 40 or desired anatomical application. Essentially, the function of the anchoring support element 60 is to provide added structural integrity and strength at the locations along which a surgeon is most likely to anchor, suture, or tack the reinforced barrier device 11' to soft tissue. Therefore, a border-like or perimeter frame, or perimeter patch-like structures having an approximate perimeter support ratio of about 3:5 (or 60%) or less is sufficient to provide adequate anchoring support. This perimeter support ratio can be calculated by determining the total area of the anchoring support element 60 and dividing it by the total area of the underlying mesh 40. The result is the ratio of about 3:5 (or 60%) or less. It should be noted, and as later discussed, the anchoring support element 60 can be continuous or can be dis-continuous; it is the total area of any anchoring support element 60 components that is compared with the total area of the underlying mesh 40 that results in the perimeter support ratio determination. An anchoring support element 60 having approximately 0.25 inches to 1 inch of width (W) extending from the edge of the mesh 40 is likely sufficient for many applications. However, it should be noted that this 0.25 inch to 1 inch dimension is merely exemplary of what may be a useful

width. More importantly, the width (W) of the anchoring support element 60 extending from the edge of the perimeter of the mesh 40 is best defined as that width dimension that is sufficient enough or required to provide enhanced strength, tear resistance, elongation prevention when implanted, and also to provide a surgeon or other medical user with adequate area to target for the insertion of anchors, sutures, tacks, adhesive, and the like, to hold the reinforced barrier device 11' in place in the patient. The duration of the anchoring function is preferably until modulated healing and cellular growth has transformed to a point whereby the underlying mesh 40 has become substantially healed or substantially incorporated with tissue to further anchor the underlying medical device and hold it in place. The additional layer of the anchoring support element 60 can be formed by either a separate layer or fold in the underlying mesh material, to significantly increase the strength and an aversion to tearing when apertures and/or button holes are created in the anchoring support element 60 and the mesh 40 to anchor the reinforced barrier device 11' in place. The additional layer of the anchoring support element 60 also significantly increases the resistance to stretching, or allowing an anchor to pull through the reinforced barrier device 11'. The anchoring support element 60, while adding strength to the device, does not significantly alter the flexibility of the reinforced barrier device 11' relative to a single layer mesh 40 with barrier layer 10. Thus, the purpose of the anchoring support element 60 is not to rigidify the mesh 40 or the overall reinforced barrier device 11'. Instead, the anchoring support element 60 is sized and dimensioned to provide anchoring reinforcement at locations where apertures are formed, or attachments are made, to anchor the reinforced barrier device 11' in place during implantation, and after patient recovery.

[00109] The anchoring support element 60 can take a number of different structural forms, including the same structure as the underlying mesh 40, with the same orientation of grids, or with slightly out of phase alignment of the cells or grid of the mesh shape. In addition, the anchoring support element 60 can take other structural forms, such as a mesh with different sized and/or shaped mesh cells or pores, a more solid structural form, a denser weave, or a structure having more cells in its mesh shape than the underlying mesh 40, or made with variable surface finishes including smooth, rough or gradual finish features. In addition, the thickness and cross-sectional shape of each thread or bar forming the mesh of the anchoring support element 60 can likewise vary relative to the underlying mesh 40. Furthermore, the anchoring support element 60 can have a different structure from a mesh structure, being more solid and more rigid.

[00110] The anchoring support element 60 is described herein as being primarily for the purpose of strengthening the mesh 40 and providing better resistance to tearing. However, it should be appreciated that the anchoring support element 60 can also be utilized to increase the rigidity of the mesh 40, or create a device that expands and straightens the mesh 40 upon implantation.

[00111] The anchoring support element 60 can be held together (permanently or temporarily) with the underlying mesh 40 prior to the application of the barrier layer 10 coating in order to hold the anchoring support element 60 in place during application of the barrier layer 10. For example, a plurality of permanent attachment welds 62 can be provided to join the anchoring support element 60 with the mesh by use of heat, pressure, and/or ultrasonic means. Alternatively, other fastening mechanisms, including temporary or permanent adhesives, or other welds (such as laser or chemical etching) can be utilized, so long as they are formed of biocompatible materials for embodiments relating to implantable devices.

[00112] In addition, it should be noted that the combination of the barrier layer 10 with the mesh 40 and the anchoring support element 60 creates a combination of components that together have increased strength while still maintaining a desired flexibility. The barrier layer 10, once cured, immobilizes the anchoring support element 60 relative to the underlying mesh 40, such that there is no slippage or movement of the anchoring support element 60 relative to the mesh 40. This results in an increased strength of the combined components that is greater than any of the individual mesh 40, anchoring support element 60, or barrier layer 10 coating independently. The immobilization of the components relative to each other increases the overall strength, while the overall structure remains flexible due primarily to the individual flexibilities of the cured barrier layer 10 and of the mesh 40 and anchoring support elements 60. Further, the barrier layer 10 acts as an adhesive to hold the mesh 40 and the anchoring support element 60 together, regardless of whether there is a weld or other form of fastening mechanism holding the two components together.

[00113] FIG. 11 is representative of a plurality of different shapes, sizes, and locations for the placement of a fragmented plurality of anchoring support elements 60'. As illustrated, the anchoring support element 60' need not be in the shape of a perimeter frame. In particular, the anchoring support element 60' can have a number of different shapes, sizes,

forms, symmetries, non-symmetries, and locations along the underlying mesh 40 structure. Ideally, if the frame structure of **FIGS. 9** and **10** is not utilized, and instead some form or collection of anchoring support elements 60' is used, then each anchoring support element 60' should be placed at locations on the mesh 40 that would be likely locations for hosting or receiving a suture, tack, anchor, or adhesive. This can include locations anywhere along the perimeter of the mesh 40, as well as locations found interior to the edge of the mesh 40.

[00114] **FIG. 12** is a cross-sectional view of the reinforced barrier device 11' of **FIGS. 9** and **10**, in accordance with one example embodiment. The reinforced barrier device 11' has the underlying mesh 40 structure with the anchoring support element 60 disposed on the mesh 40 for a portion of the mesh 40 surface area. Both of the mesh 40 and the anchoring support element 60 are encapsulated within the barrier layer 10, which in this embodiment is of the type described in the method of **FIG. 7** herein, where an oil component or oil composition is applied to the mesh structure, falls substantially to a bottom side of the mesh 40 (due to gravitational pull) leaving a thinner coating or amount at a top side of the mesh 40, but still substantially encapsulating the mesh within the liquid of the barrier layer 10 material. The combined oil component/composition and mesh 40 are then cured to form the barrier layer 10 in combination with the mesh 40, i.e., the reinforced barrier device 11'. It should be noted that the barrier layer can be finished a number of different ways, including as an irregular roughened or non-smooth surface, as a smooth surface, or any combination of rough and smooth surface finishes, which impacts the degree of delay resulting in the modulated healing process, and also influences the limits placed on adhesion formations.

[00115] In one embodiment illustrated in **FIG. 12**, the barrier layer material is particularly proficient at smoothing out a transition 64 between the anchoring support element 60 and the underlying mesh 40. As can be seen in **FIG. 12**, the transition 64 between the anchoring support element 60 and the mesh 40 is actually a step between the two components that can be made more gradual or is smoothed out by the oil component/composition as it spreads and covers the two mesh devices to form a single unified device. The underlying abrupt step transition is smoothed over by the more gradual drop of the oil component/composition used to form the barrier layer 10, which is then cured to maintain the smoothing transition 64. This optional smooth transition 64, depending on the location of the reinforced barrier device 11' implantation, can be helpful in reducing or eliminating an edge that would otherwise fill in with connective tissue. If the anchoring support element 60 were tack

welded, or otherwise fixed, to the underlying mesh 40 and implanted in a patient without the addition of the oil component/composition that is cured to form the barrier layer, then there would be a more abrupt step transition that would exhibit a more pronounced edge. The optional smooth transition 64 created by the provision of the barrier layer 10 in combination with the anchoring support element 60 and the underlying mesh 40 structure creates a reinforced barrier device 11' that does not have any abrupt or sharp edges that could cause irritation when placed against tissue. Over time, the bioabsorbable barrier layer 10 is absorbed into the tissue (along with any therapeutic agent that may be provided in the barrier layer 10) and tissue in-growth occurs, replacing the barrier layer 10 and smooth transition 64 with healed tissue.

[00116] It should be additionally noted that **FIG. 12** further illustrates that which has been previously described, which is the existence of a relatively thinner barrier layer 10 at a top side 66 of the reinforced barrier device 11' and a relatively thicker barrier layer 10 at a bottom side 68 of the reinforced barrier device 11'. This, again, is the result of the oil component/composition being applied to the mesh structure and sliding down (due to gravity) to pool at the bottom side 68 of the mesh 40 prior to being cured. Once cured, the barrier layer 10 maintains this structure until implanted and absorbed away over time. The thicker barrier layer 10 on the bottom side 68 of the mesh 40 can provide desired smooth side (or alternatively a rough finish despite being thicker) of the reinforced barrier device 11', while the top side 66 of the reinforced barrier device 11' has the thinner barrier layer 10 resulting a less smooth (i.e., irregular) finish creating the rougher side. The rougher side provides an environment more predisposed to promoting faster tissue in-growth or surface incorporation, while the smoother bottom side 68 exhibits a more delayed form of the modulated healing and is more predisposed to provide an extended adhesion-limiting functionality.

[00117] As understood by one of ordinary skill in the art, the properties of the mesh 40 and the barrier layer 10 can vary. There may be a requirement for the mesh 40 to have one side, or a portion of a side (or of the barrier layer surface), that has adhesion-limiting properties and modulated healing properties for a period of several days. Alternatively, multiple sides of the mesh 40 may be required to have extended modulating healing or extended adhesion-limiting properties. As such, the barrier layer 10 can be applied to all sides, or portions of sides, or portions of one side of the mesh 40.

[00118] In addition, the requirement may be for the adhesion-limiting properties to last several weeks, or even longer. Accordingly, the rate of bioabsorption can also be varied by changing such properties as amount of cross-linking, thickness, and existence of additives, such as vitamin E compounds to achieve longer or shorter term adhesion-limiting properties. In addition, there may be a desire to include a therapeutic agent to reduce inflammation, provide antibiotic therapy, or other therapeutic measures, in combination with the use of the mesh 40. Accordingly, the therapeutic agent(s) can be added to the barrier layer 10 to achieve the desired controlled release of the therapeutic agent after implantation. As previously described, combinations of cured oils top coated with lesser cured or non-cured oils and therapeutic agents can form the barrier layer 10.

[00119] The particular properties or characteristics of the mesh 40 are determined based on the desired use of the mesh 40. A common implementation is for the mesh 40 to be formed of a bio-compatible material, such as polypropylene, however other bio-compatible materials can be utilized, such as a mesh formed of the same or similar substance as the barrier layer 10 (i.e., oil based).

EXAMPLE #1

[00120] An embodiment of the present invention was implemented in a rat model to demonstrate the performance of the barrier layer of the present invention relative to other known surgical mesh devices. The devices were implanted in a rat to repair abdominal wall defects. Healing characteristics, adhesion formation and tenacity, and inflammatory response associated with these materials were compared.

[00121] A polypropylene mesh material (PROLITE™) provided by Atrium Medical Corporation of Hudson, NH, coated with one embodiment of the barrier layer described herein. The polypropylene mesh with barrier layer was compared with a bare polypropylene control mesh, and DUALMESH® biomaterial provided by W. L. Gore & Associates, Inc.

[00122] Five samples of each mesh type were implanted according to a random schedule. On the day of surgery, the animals were anesthetized with an injection of 50 mg/kg Nembutal IP. The animal was prepped for surgery, and a midline abdominal incision was made. A portion of rectus muscle and fascia was removed leaving an approximately 20mm

x 30mm full thickness defect in the abdominal wall. Using 4-0 Prolene, the appropriate patch was sutured into place repairing the existing defect. An overlap of mesh was placed over the defect to ensure proper repair, with the mesh samples being 2.5 cm x 3.5 cm in size. The mesh was placed such that the smoother side was toward the viscera in the case of the polypropylene mesh with barrier layer, and the appropriate side of the Gore DUALMESH® was also placed towards the viscera. Suture knots were made on the abdominal wall side of the implant rather than the visceral side as to not interfere with tissue attachment. The mesh was sutured around the entire perimeter to ensure adequate placement. The subdermal and subcutaneous layers were closed with Vicryl. The skin was closed using surgical staples. The animals received Buprenorphine for pain. The mesh was explanted at approximately 30 days.

Sample Explanation:

[00123] Approximately 30 days after implantation, the animals were again anesthetized for explant of the mesh samples. The skin staples were removed, and a vertical incision through the skin and subcutaneous tissue was made lateral to both the implantation site and patch. Through this incision, the implant was inspected and photos were taken to document adhesion formation. Upon gross examination, the same investigator evaluated each sample for adherent intraperitoneal tissues and assigned an adhesion grade to each sample (Jenkins SD, Klamer TW, Parteka JJ, and Condon RE. A comparison of prosthetic materials used to repair abdominal wall defects. *Surgery* 1983; 94:392-8). In general, the adhesions were scored as: 0- no adhesions; 1- minimal adhesions that could be freed by gentle blunt dissection; 2- moderate adhesions that could be freed by aggressive blunt dissection; 3- dense adhesion that require sharp dissection.

[00124] Once the gross evaluation was complete, the mid-portion of the abdominal cavity was excised including the implant, and adhesive tissue not completely separated from the implant, and the overlying subcutaneous and skin. Sections were then fixed and processed for histological evaluation. The histology samples were stained with Hematoxylin and Eosin, Trichrome, GS1, and Vimentin.

Results

Polypropylene Mesh Control:

[00125] These patches had a mean adhesion score of 2.1. Adhesions consisted of omentum, epididymal fat, and one had intestinal adhesions. Many of the adhesions were at the edges of the patch/tissue interface. The adhesions required aggressive blunt dissection to remove them. There was a moderate inflammatory response associated around the fibers of the mesh. There was a tight association of fat to the implant surface on the peritoneal cavity side, meaning the adhesions were not fully removed.

Gore DUALMESH® Control:

[00126] Patches were entirely covered with adhesions. The adhesions consisted of epididymal fat, omentum and bowel. The mean adhesion score was 2.9. There was a capsule covering the entire patch that needed sharp dissection to free from material. Adhesions pulled free from capsule with blunt dissection. A moderate to severe inflammatory response was observed in association with the skin side of the implant. The thin fibrous capsule on the peritoneal side of the implant was avascular and in some implants was loosely adherent to associated tissue.

Polypropylene Mesh with Barrier Layer (embodiment of present invention):

[00127] These patches had a mean adhesion score of 1.6. Adhesions included epididymal fat and some omentum. The adhesions dissociated from the patches relatively easily. There was a mild to minimal inflammatory response associated with the exposed polypropylene fibers of this material. Vimentin staining showed a layer of mesothelial cells formed on the tissue on the peritoneal cavity side of the implant.

[00128] The polypropylene mesh with barrier layer in accordance with one embodiment of the present invention showed good results in terms of adhesion minimization, tenacity of adhesions formed, and a low inflammatory response. The coated mesh product was also easy to handle, place, and suture for repair of an abdominal wall defect in this model.

EXAMPLE #2

[00129] Mechanical testing has been conducted showing an increase in burst strength with the reinforcement element compared to a device without the additional reinforcement element. Testing was conducted using an Instron device to measure burst strength both with and without a 5 mm titanium tack inserted into the device. The material was hydrated in phosphate buffered saline for 1 hour at 37 °C. A 1" x 3" strip was laid over a piece of 0.5" thick rubber backing material, and the 5 mm ProTack titanium helical tack was used to fasten the mesh to the underlying rubber substrate. The test strip, with the rubber attached was laid over a cylinder with a 1.875" opening in the center that was attached to the bottom jaw of the Instron device. A ring of the same diameter was placed on top of the mesh strip and clamped in place to keep the material from moving during the test. A 0.25" diameter rod was attached to the top Instron jaw, directly above the mesh. The rod was forced through the mesh where the tack was inserted at a constant displacement rate of 300 mm/min and the burst strength of the mesh was recorded. Strips of mesh without tacking were tested in a similar manner to determine the effect of the tack on the burst strength of the material. The results are shown in the chart below:

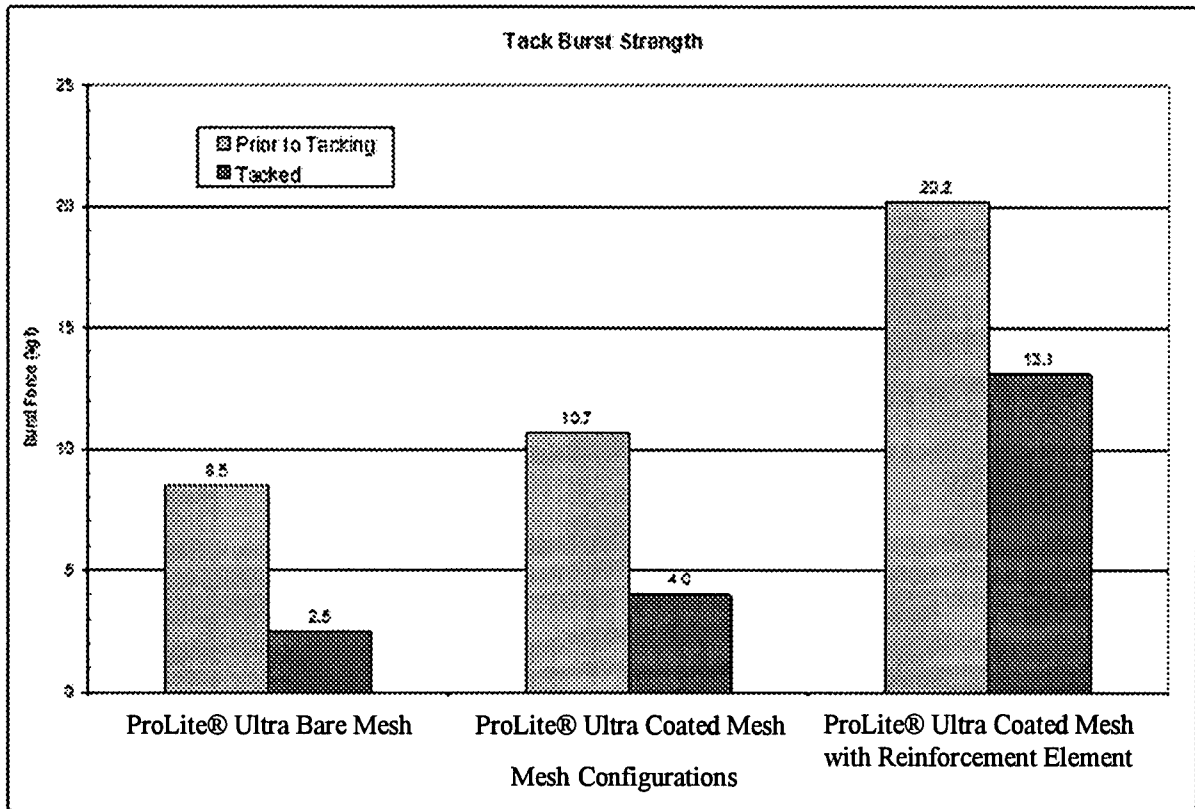

[00130] These data clearly show that the inventive article significantly increases the mechanical fixation strength.

[00131] The oil component itself, in the form of fish oil for example, can provide therapeutic benefits in the form of reduced inflammation, and improved healing, if the fish oil composition is not substantially modified during the process that takes the fish oil and forms it into the barrier layer 10. Some prior attempts to use natural oils as coatings have involved mixing the oil with a solvent, or curing the oil in a manner that destroys the beneficial aspects of the oil. The solvent utilized in the example barrier layer 10 embodiment of the present invention (NMP) does not have such detrimental effects on the therapeutic properties of the fish oil. Thus, the benefits of the omega-3 fatty acids, and the EPA and DHA substances are substantially preserved in the barrier layer of the present invention.

[00132] Therefore, the barrier layer 10 of the present invention includes the bio-absorbable biocompatible oil (i.e., fish oil). The barrier layer 10 is thus able to be absorbed by the cells of the body tissue. With the present invention, because of the lipophilic action enabled by the bio-absorbable lipid based barrier layer 10 of the present invention, the intake by the tissue cells of the barrier layer 10, and any therapeutic agent component, is substantially controlled by the cells themselves. In configurations using polymer based materials, the drugs were released at a rate regardless of the reaction or need for the drug on the part of the cells receiving the drug. With the barrier layer 10 of the present invention, the cells can intake as much of the barrier layer 10, and correspondingly the therapeutic agent, as is needed by the damaged cell requiring treatment.

[00133] In addition, the bio-absorbable nature of the barrier layer 10 results in the barrier layer 10 being completely absorbed over time by the cells of the body tissue. There is no break down of the barrier layer 10 into sub parts and substances that are inflammatory and are eventually distributed throughout the body and in some instances disposed of by the body, as is the case with biodegradable synthetic polymer coatings. The bio-absorbable nature of the barrier layer 10 of the present invention results in the barrier layer 10 being absorbed, leaving only the medical device structure, if the barrier layer 10 is not implanted alone. There is no inflammatory foreign body response to the barrier layer 10.

[00134] Furthermore, the barrier layer 10 provides a lubricious and/or adhesive surface against tissue, such that the layer sticks or adheres to tissue against which it is placed. The barrier layer 10 can additionally provide an adhesion-limiting barrier between two sections

of tissue, or the barrier layer 10 can form an adhesion-limiting surface on a medical device, such as the mesh 40. The use of the naturally occurring oil, such as fish oil, provides extra lubrication to the surface of the medical device, which helps to reduce injury. With less injury, there is less of an inflammatory response and less healing required. Likewise the fatty acid derived cross-linked gel that makes up the barrier layer maintains anti-inflammatory properties which also substantially lowers the inflammatory response of the tissue. The reduced inflammation also reduces adhesions.

[00135] Combination of the barrier layer 10 coating or material with the mesh 40, and in some instances the mesh 40 and anchoring support element 60, creates the barrier device 11, 11' that exhibits strong structural integrity, a resistance to tearing even when punctured, and good flexibility, while also providing an adhesion-limiting, anti-inflammatory, and/or non-inflammatory coating that is fully bioabsorbable leaving a biocompatible structure that supports tissue in-growth and encapsulation. The added strength of the anchoring support element 60 provides a swath (or additional layer) of mesh material through which the medical user can insert anchors, sutures, or tacks, or to which adhesive can be applied, to hold the barrier device 11, 11' in place until the tissue grows to envelope the barrier device 11, 11'. The barrier layer 10 provides for a smooth transition between instances of the anchoring support element 60 and the underlying mesh 40 structure, preventing irritation from abrupt edges of material. The flexibility of the mesh 40 is likewise maintained even with the addition of the anchoring support element 60.

[00136] FIG. 13 is a flowchart illustrating an example method of forming the reinforced barrier device 11'. A surface is prepared with a release agent, such as PVA (step 190), as needed. The medical device is placed on the surface (step 192). In the example embodiment, the medical device is the mesh 40 tack welded or otherwise fastened together with the anchoring support element 60. It should be noted that the attachment of the anchoring support element 60 can occur prior to the present illustrative method, as described, or can be a step in the formation of the reinforced barrier device 11'. In addition, and as illustrated, the anchoring support element 60 can include a plurality of anchoring support elements 60 disposed on the mesh 40, if desired. The oil component or oil composition is applied to the medical device (step 194). In the instance of the mesh 40, the oil component or oil composition is poured or sprayed onto the mesh 40. In such an embodiment the barrier layer 10 will fall substantially to a bottom side of the mesh 40 (due to gravitational

pull), leaving a thinner coating or amount at a top side of the mesh 40, but still substantially encapsulating the mesh within the liquid of the barrier layer 10 material. The combined oil component/composition and mesh 40 are then cured (step 196) using methods such as application of heat, UV light, oxygen and other reactive gases, chemical cross-linker, or hardening processes, to form the barrier layer in combination with the mesh 40. The combined barrier layer and mesh are then removed from the surface (step 198) and the release agent is washed away (step 200), leaving the reinforced barrier device 11'.

[00137] As with previous methods, if desired, a therapeutic agent can be added to the oil component or oil composition at any point along the process forming the combined barrier layer 10 and mesh 40, including being a component of the oil composition. As discussed previously, consideration must be given as to whether the therapeutic agent may be affected by the curing process, or other aspects of the process.

[00138] Furthermore, the formation of the oil composition can be done in accordance with different alternatives to the methods described. For example, prior to forming the barrier layer 10, a preservative and/or compatibilizer, such as Vitamin E can be mixed with the oil component to form the oil composition. A solvent can be mixed with a therapeutic agent, and then added to the oil to form the oil composition. The solvent can be chosen from a number of different alternatives, including ethanol or N-Methyl-2-Pyrrolidone (NMP). The solvent can later be removed with vacuum or heat.

[00139] In addition, it should again be noted that the oil component or oil composition can be added multiple times to create multiple tiers in forming the barrier layer 10. If a thicker barrier layer 10 is desired, additional tiers of the oil component or oil composition can be added after steps 194 and 196. Different variations relating to when the oil is hardened or cured and when other substances are added to the oil are possible in a number of different process configurations. Accordingly, the present invention is not limited to the specific sequence illustrated. Rather, different combinations of the basic steps illustrated are anticipated by the present invention.

[00140] **FIG. 14** is a diagrammatic illustration of yet another embodiment of a reinforced barrier device 11'' in accordance with aspects of the present invention. The reinforced barrier device 11'' includes the underlying mesh 40, and the anchoring support element 60.

In addition, a second layer of anchoring support element 60' is provided on top of the first anchoring support element 60, prior to combination with the barrier layer 10. The second layer of anchoring support element 60' provides even further strengthening of the reinforced barrier device 11'', increasing the resistance to tearing, and providing additional rigidity because of the increasing number of layers. With the addition of the second layer of anchoring support element 60', a smoothing transition 64' requires more of the barrier layer 10 to fill in the step between the second layer of anchoring support element 60' and the underlying mesh 40. One of ordinary skill in the art will appreciate that a plurality of layers of anchoring support elements 60, 60' can be coupled together and then combined with the barrier layer 10. The number of layers can vary to change strength and rigidity characteristics, and the materials used for each layer can also vary.

[00141] **FIGS. 15A and 15B** are diagrammatic illustrations of additional embodiments of a reinforced barrier device 11''', and 11'''' in accordance with further aspects of the present invention. The reinforced barrier device 11''' includes the underlying mesh 40, and an anchoring support element 60''. The anchoring support element 60'' provides a different mesh pattern from the underlying mesh 40. In addition, the anchoring support element 60'' is offset from the underlying mesh 40, meaning that the apertures between the mesh 40 elements are at least partially blocked by the anchoring support element 60''. A smoothing transition 64'' fills in the step between the anchoring support element 60'' and the underlying mesh 40, as with other embodiments. In addition, the anchoring support element 60'' is formed of a different material from that of the underlying mesh 40. Furthermore, in **FIG. 15B**, the reinforced barrier device 11'''' includes the underlying mesh 40, and an anchoring support element 60'''. The anchoring support element 60''' provides still another mesh pattern from the underlying mesh 40. In addition, the anchoring support element 60''' is offset from the underlying mesh 40, meaning that the apertures between the mesh 40 elements are at least partially blocked by the anchoring support element 60'''. A smoothing transition 64''' fills in the step between the anchoring support element 60''' and the underlying mesh 40, as with other embodiments. In addition, the anchoring support element 60''' is formed of a different material from that of the underlying mesh 40, and is itself formed of two different materials. The weave density of the anchoring support element 60''' is also greater than that of the underlying mesh 40, while the weave density of the anchoring support element 60'' of **FIG. 15A** is less dense than that of the underlying mesh 40. One of ordinary skill in the art will additionally appreciate that a variety of materials having

different material properties can be used to vary the strength and rigidity characteristics of the barrier devices described herein.

[00142] The barrier devices 11 of the present invention with their anchoring support elements 60 as described herein all further exhibit a feature that greatly improves visibility of the device during an implantation procedure. Specifically, through the light transmitting properties of the barrier layer 10, and specifically through the characteristics of the oil-based material that is utilized to form the barrier layer as described herein, the edges of the barrier devices 11 are illuminated when a light is applied to the barrier devices 11. Specifically, when a light is provided at various angles to illuminate an area during a surgical operation, including implantation of a barrier device 11, the light translates through the barrier layer 10 and at any cut or otherwise terminating edge, the edge is illuminated in a manner that outlines or highlights the edge relative to the other portions of the barrier device 11. This illumination of the edges of the barrier devices 11 makes it easier for a surgical user to find the edges and know where the reinforcing anchoring support elements 60 are placed on the underlying mesh, due to the light that outlines or highlights the relevant edges.

[00143] Numerous modifications and alternative embodiments of the present invention will be apparent to those skilled in the art in view of the foregoing description. Accordingly, this description is to be construed as illustrative only and is for the purpose of teaching those skilled in the art the best mode for carrying out the present invention. Details of the structure may vary substantially without departing from the spirit of the present invention, and exclusive use of all modifications that come within the scope of the appended claims is reserved. It is intended that the present invention be limited only to the extent required by the appended claims and the applicable rules of law.

[00144] It is also to be understood that the following claims are to cover all generic and specific features of the invention described herein, and all statements of the scope of the invention which, as a matter of language, might be said to fall therebetween.

CLAIMS

What is claimed is:

1. A barrier layer device, comprising:
 - a base surgical mesh structure;
 - at least one anchoring support element disposed on a surface of the surgical mesh structure and configured to receive an anchoring mechanism; and
 - a barrier layer formed on at least a portion of the surgical mesh structure and the at least one anchoring support element;wherein the barrier layer is formed of a non-polymeric cross-linked gel.
2. The device of claim 1, wherein the at least one anchoring support element comprises a biocompatible mesh.
3. The device of claim 1, wherein the cross-linked gel is derived from at least one fatty acid compound.
4. The device of claim 1, wherein the barrier layer generates a modulated healing effect on injured tissue in contact with the barrier layer through a cellular absorption process that delays contact by the injured tissue with the base surgical mesh structure until cell remodeling can begin.
5. The device of claim 1, wherein the barrier layer comprises a biological oil barrier, a physical adhesion-limiting barrier, or both.
6. The device of claim 1, wherein the cross-linked gel comprises one or more of an oil that is at least partially cured, an oil composition that is at least partially cured, a biological oil that is at least partially cured, or a fish oil that is at least partially cured.
7. The device of claim 1, wherein the cross-linked gel is derived from oil containing at least one component selected from a group of components comprised of lipids and omega-3 fatty acids.

8. The device of claim 1, wherein the barrier layer comprises at least one therapeutic agent component.
9. The device of claim 8, wherein the therapeutic agent component comprises an agent selected from a group consisting of antioxidants, anti-inflammatory agents, anti-coagulant agents, drugs to alter lipid metabolism, anti-proliferatives, anti-neoplastics, tissue growth stimulants, functional protein/factor delivery agents, anti-infective agents, imaging agents, anesthetic agents, chemotherapeutic agents, tissue absorption enhancers, adhesion-limiting agents, germicides, analgesics, prodrugs, and antiseptics.
10. The device of claim 1, wherein the barrier layer is configured to provide controlled release of a therapeutic agent component.
11. The device of claim 1, wherein the barrier layer comprises an oil composition that includes an oil component in combination with at least one component selected from a group of components comprised of an additional oil component, a therapeutic agent component, a solvent, and a preservative.
12. The device of claim 1, wherein the barrier layer is bio-absorbable.
13. The device of claim 1, wherein the barrier layer maintains anti-inflammatory properties.
14. The device of claim 1, wherein the barrier layer comprises a cured cross-linked gel derived from at least one fatty acid compound and an interdispersed biological oil, such that the cured cross-linked gel and the biological oil create a biological oil barrier and a physical adhesion-limiting barrier on the surgical mesh structure and the at least one anchoring support element.
15. The device of claim 1, wherein the barrier layer is configured on two sides of the surgical mesh structure.
16. The device of claim 1, wherein the barrier layer further comprises alpha-tocopherol or a derivative or analog thereof.

17. The device of claim 1, further comprising at least a second anchoring support element disposed on a surface of the at least one anchoring support element.
18. The device of claim 1, wherein the at least one anchoring support element maintains structurally different material properties from the surgical mesh structure.
19. The device of claim 1, where the at least one anchoring support element maintains a structurally different mesh pattern from the surgical mesh structure.
20. The device of claim 1, wherein the barrier layer comprises a layer of material disposed on strands of the surgical mesh structure, such that the coating provides the barrier layer between the strands and any bodily fluid or tissue upon implantation in a patient.
21. The device of claim 1, wherein the barrier layer comprises a layer of material encapsulating the surgical mesh structure.
22. The device of claim 1, wherein the barrier layer encapsulates the surgical mesh structure with a relatively thinner layer on a first side of the surgical mesh and a relatively thicker layer on an opposite side of the surgical mesh.
23. The device of claim 1, wherein the barrier layer encapsulates the surgical mesh structure while maintaining interstitial spaces between struts of the surgical mesh structure.
24. A barrier layer device, comprising:
 - a base surgical mesh structure;
 - at least one anchoring support element disposed on a surface of the surgical mesh structure and configured to receive an anchoring mechanism; and
 - a barrier layer formed on at least a portion of the surgical mesh structure and the at least one anchoring support element;wherein the barrier layer is formed of a non-polymeric cross-linked gel; and
wherein the barrier layer smoothes the surface of the surgical mesh, which is configured for positioning against tissue upon implantation.
25. A barrier layer device, comprising:

a base surgical mesh structure;
at least one anchoring support element disposed on a surface of the surgical mesh structure and configured to receive an anchoring mechanism; and
a barrier layer formed on at least a portion of the surgical mesh structure and the at least one anchoring support element;
wherein the barrier layer is formed of a non-polymeric cross-linked gel having a modulated healing effect on injured tissue when placed against the injured tissue upon implantation.

26. A method of making a barrier layer device, the method comprising:

providing a surgical mesh structure;
disposing at least one anchoring support element on a surface of the surgical mesh structure configured to receive an anchoring mechanism;
coupling the at least one anchoring support element to the surgical mesh structure;
and
creating a barrier layer formed on at least a portion of the surgical mesh structure and the at least one anchoring support element;
wherein the barrier layer is formed of a non-polymeric cross-linked gel.

27. The method of claim 26, wherein the at least one anchoring support element comprises a surgical mesh structure.

28. The method of claim 26, further comprising providing at least a second anchoring support element disposed on a surface of the at least one anchoring support element.

29. The method of claim 26, wherein the at least one anchoring support element maintains structurally different material properties from the surgical mesh structure.

30. The method of claim 26, where the at least one anchoring support element maintains a structurally different mesh pattern from the surgical mesh structure.

31. The method of claim 26, wherein creating the barrier layer comprises:
providing a biological oil or oil composition;

applying the oil or oil composition to the surgical mesh structure and the at least one anchoring support element; and

curing the oil or oil composition on the surgical mesh structure and the at least one anchoring support element to form the barrier layer.

32. The method of claim 31, further comprising partially curing the biological oil or oil composition prior to applying the oil or oil composition to the surgical mesh structure and the at least one anchoring support element to thicken the oil or oil composition.

33. The method of claim 31, further comprising applying the oil or oil composition using multiple tiers.

34. The method of claim 31, further comprising applying an additional tier of oil or oil composition after curing the oil or oil composition on the barrier layer device.

35. The method of claim 26, wherein curing comprises applying a curing mechanism selected from a group of curing mechanisms comprising heat, UV light, chemical means, and reactive gasses.

36. The method of claim 26, wherein the cross-linked gel is derived from at least one fatty acid compound.

37. The method of claim 26, wherein the barrier layer comprises at least one type of layer selected from a group of layers comprising a biological oil barrier and a physical adhesion-limiting barrier.

38. The method of claim 26, further comprising adding at least one therapeutic agent to the barrier layer.

39. The method of claim 26, wherein the barrier layer is configured to provide controlled release of a therapeutic agent component.

40. The method of claim 26, wherein the barrier layer is bio-absorbable.

41. The method of claim 26, wherein the barrier layer maintains anti-inflammatory properties.
42. The method of claim 26, wherein the barrier layer further comprises alpha tocopherol or a derivative or analog thereof.
43. The method of claim 26, further comprising sterilizing the barrier layer, surgical mesh structure, and the at least one anchoring support element with a method of sterilization selected from a group of methods of sterilization comprising ethylene oxide, gamma radiation, e-beam, steam, gas plasma, and vaporized hydrogen peroxide (VHP).

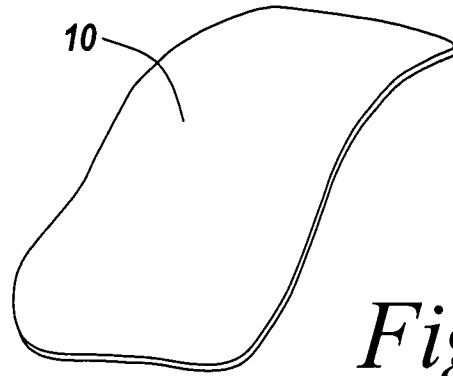

Fig. 1

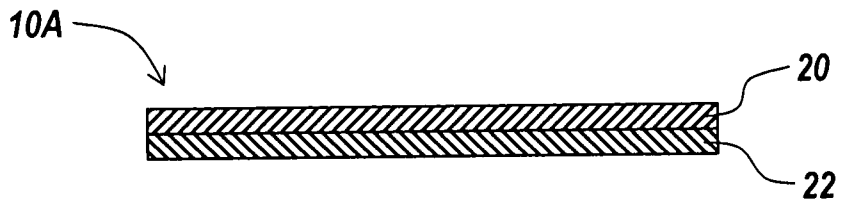

Fig. 2A

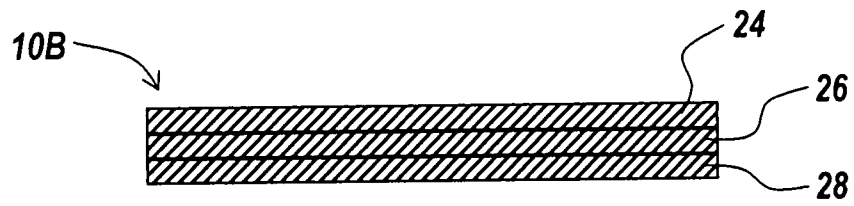

Fig. 2B



Fig. 2C

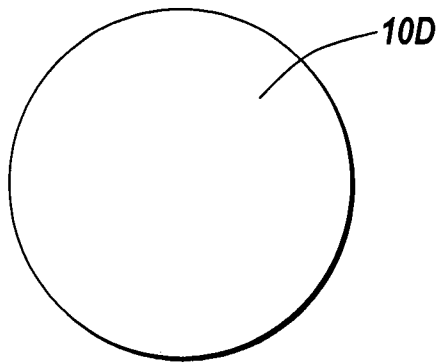

Fig. 3A

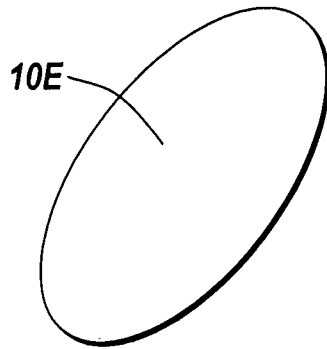

Fig. 3B

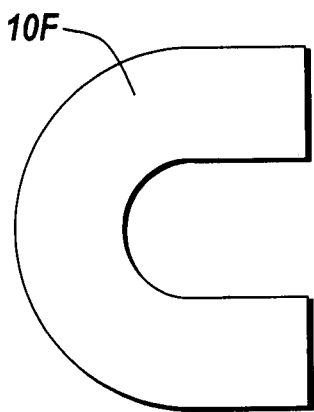

Fig. 3C

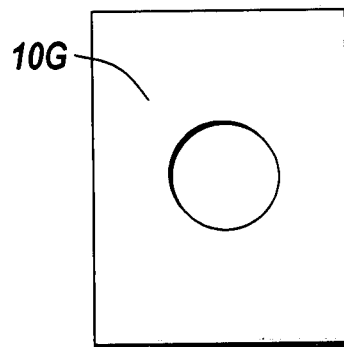

Fig. 3D

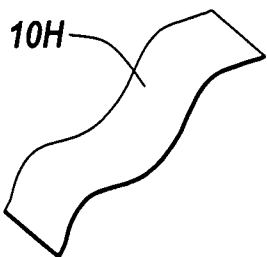

Fig. 3E

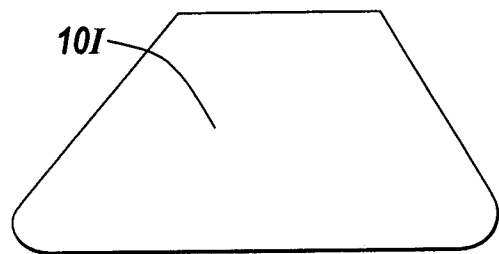
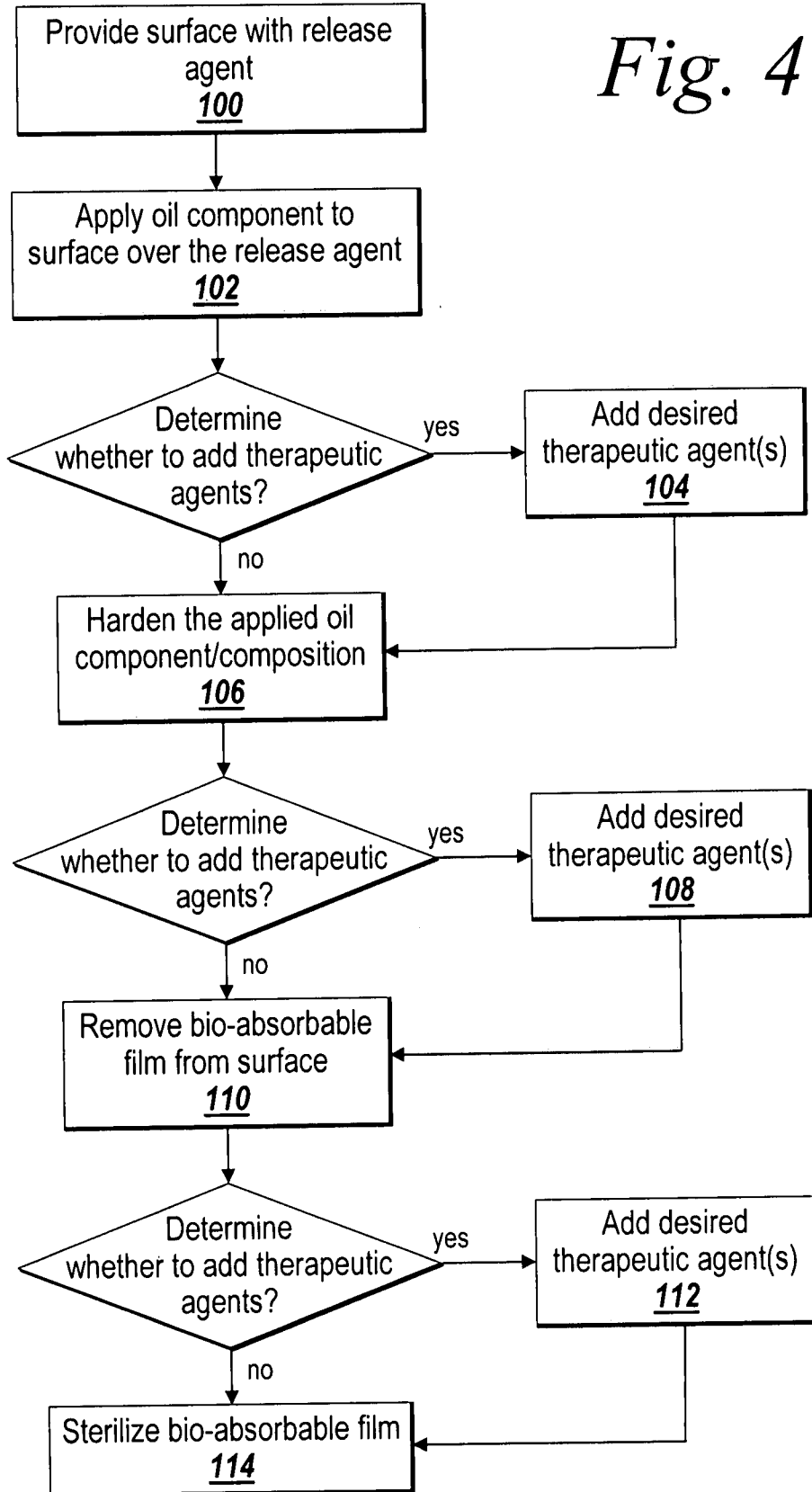

Fig. 3F

Fig. 4



4/11

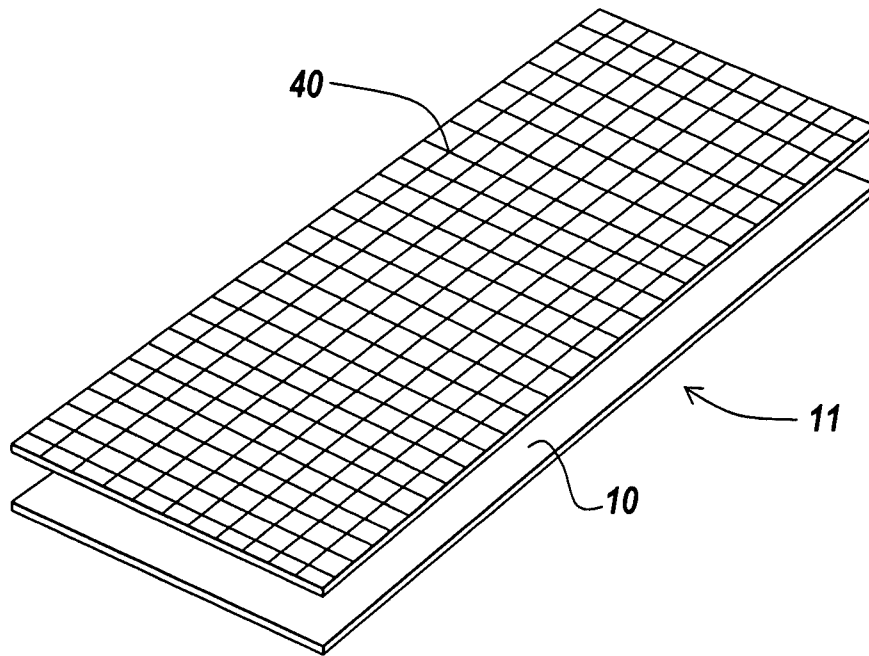

Fig. 5A

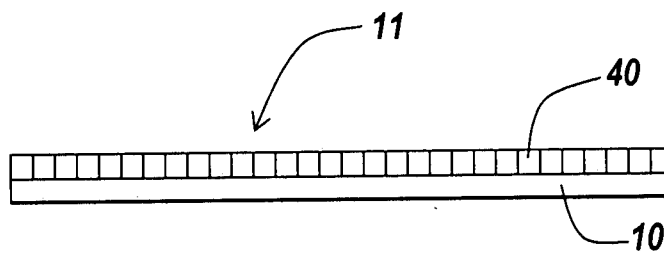
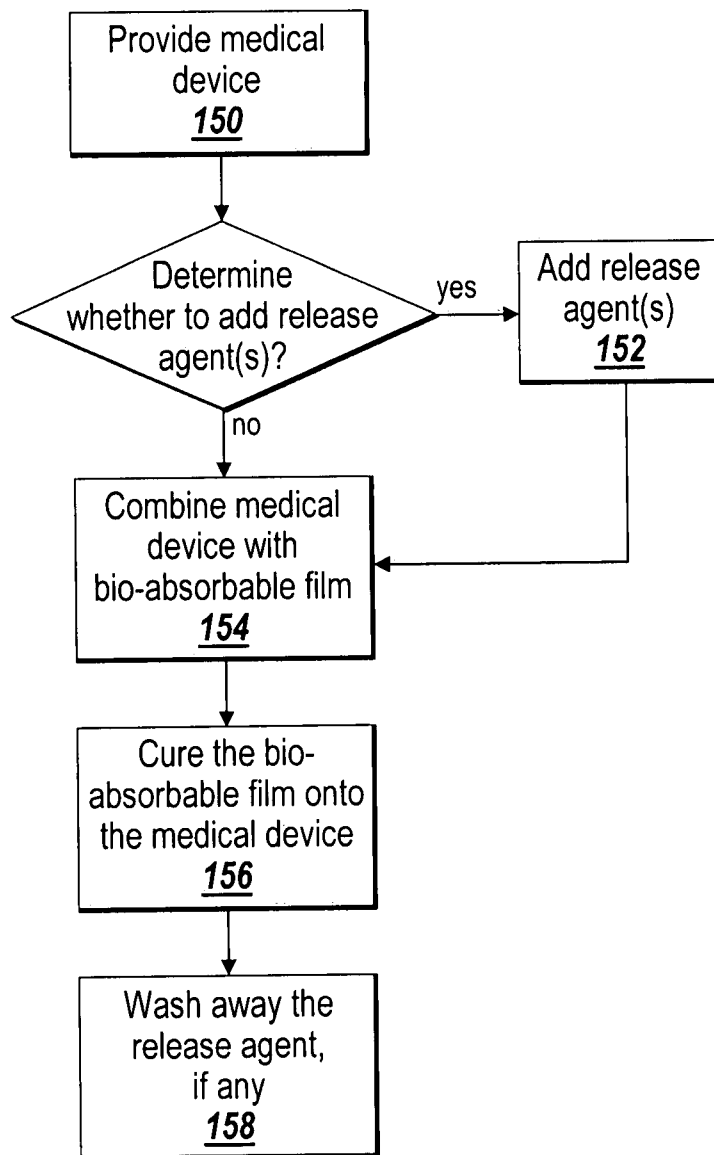
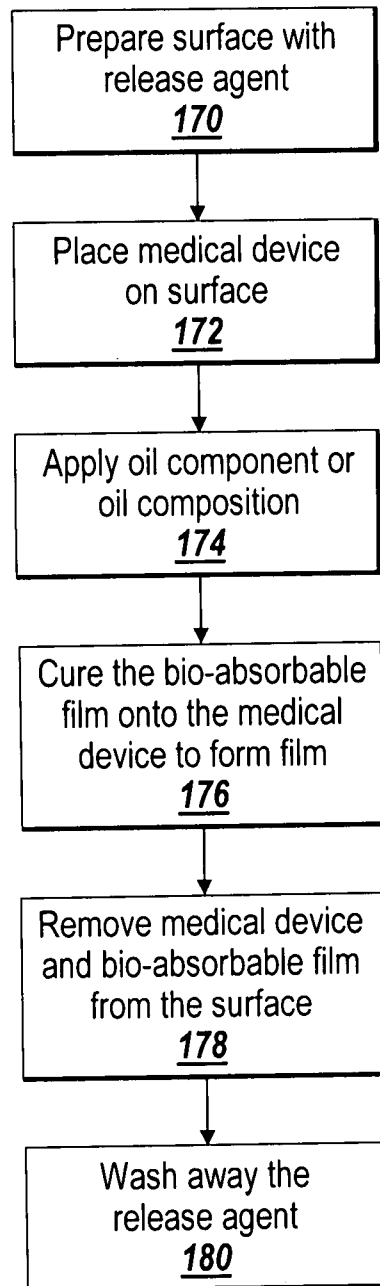

Fig. 5B

5/11

*Fig. 6*

6/11

*Fig. 7*

7/11

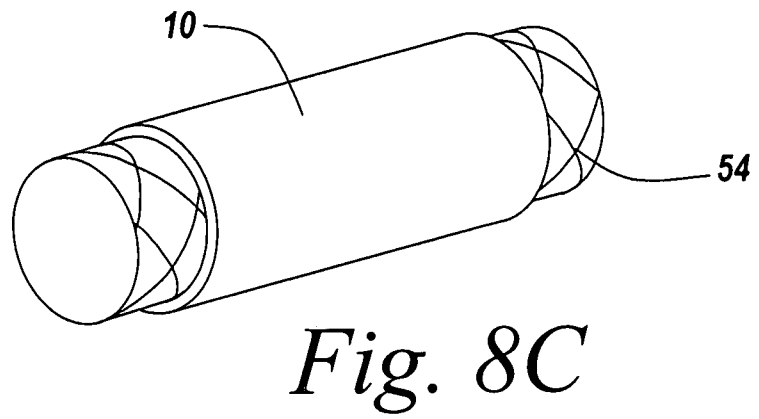
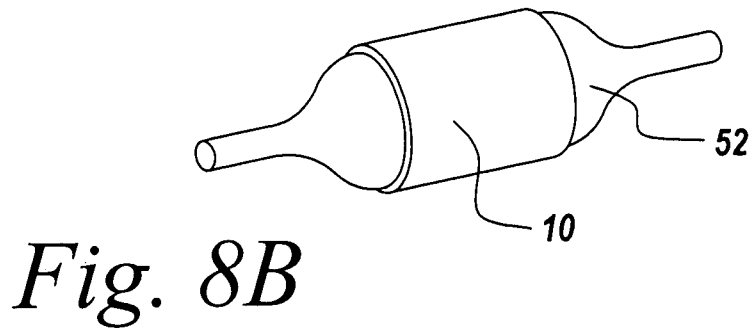
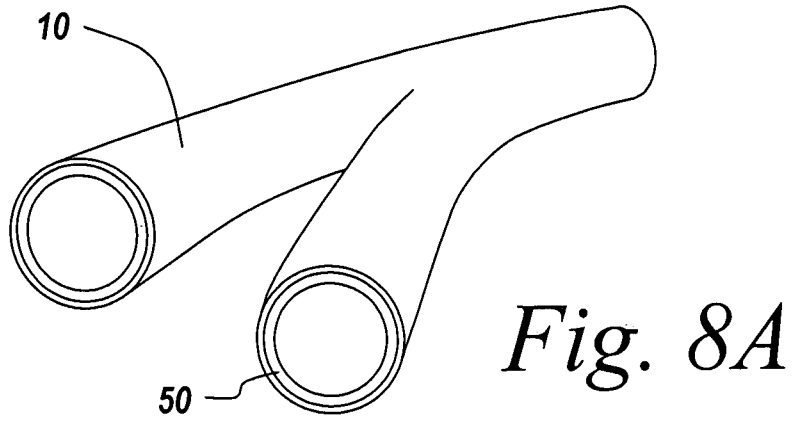

8/11

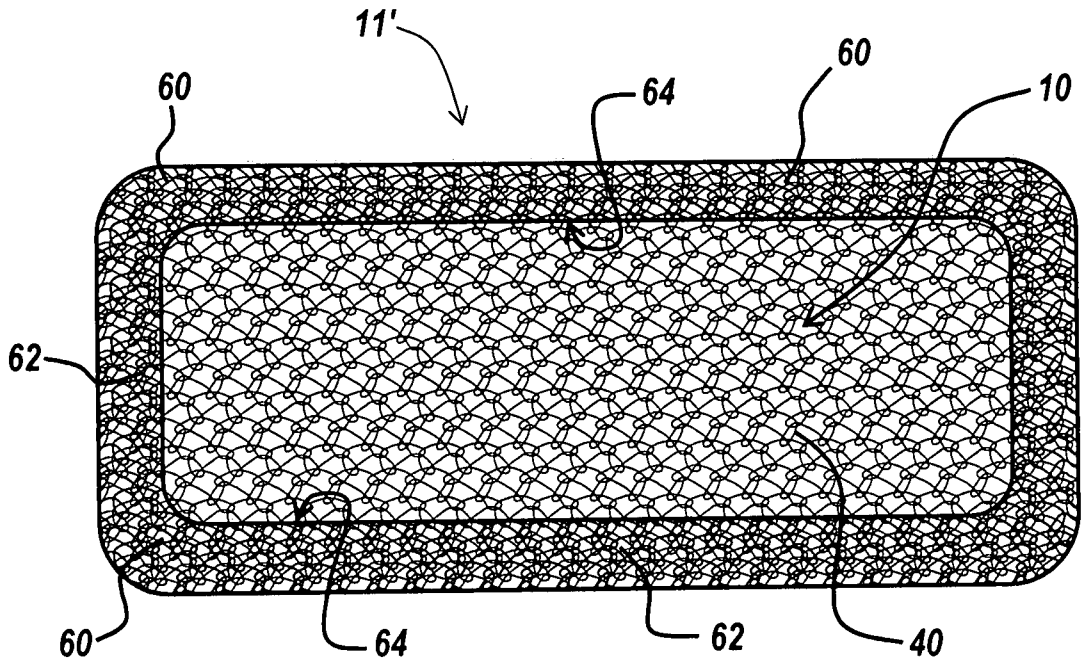

Fig. 9

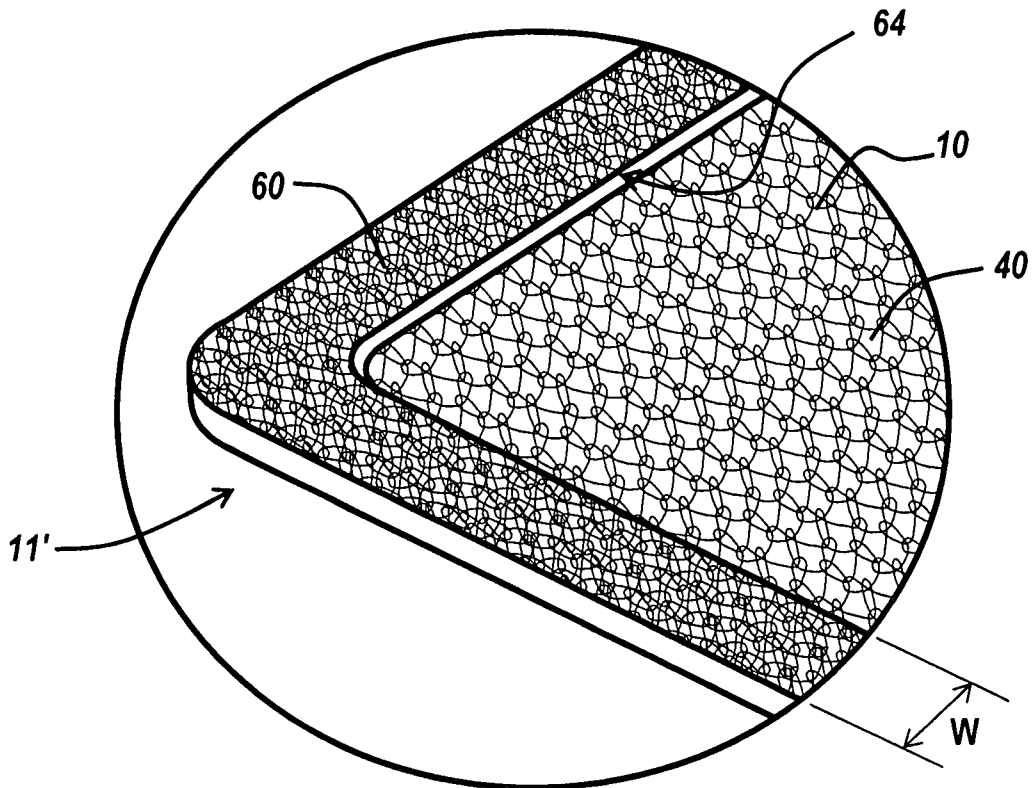

Fig. 10

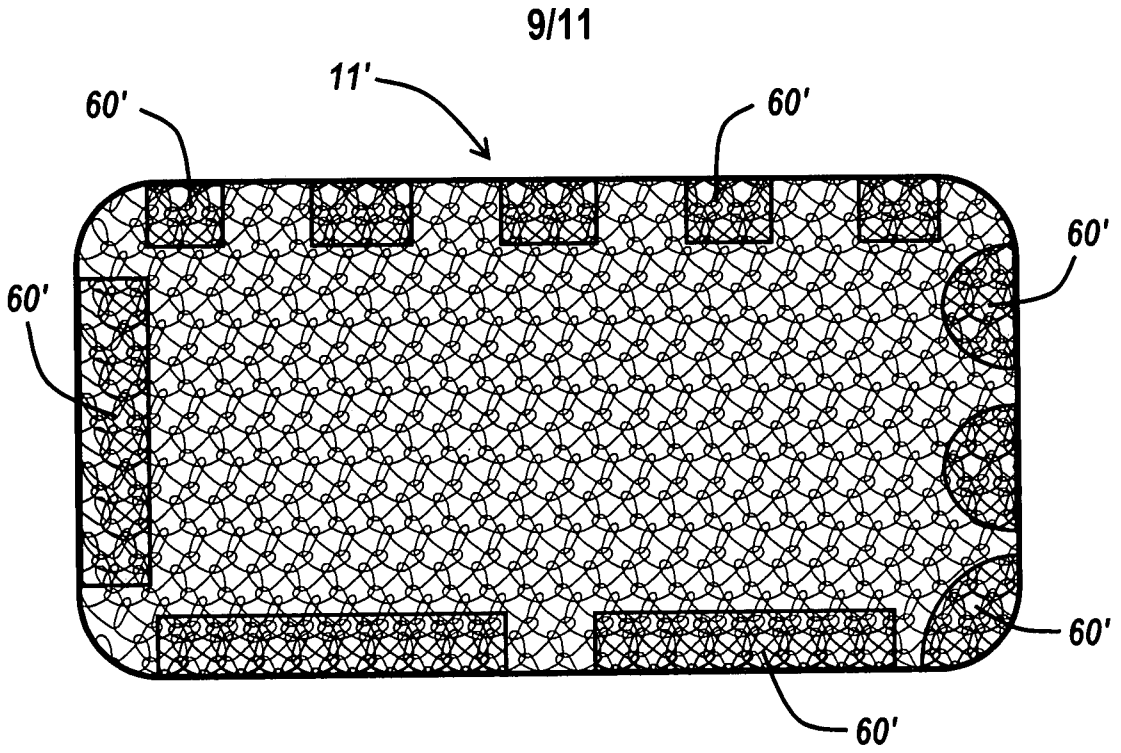

Fig. 11

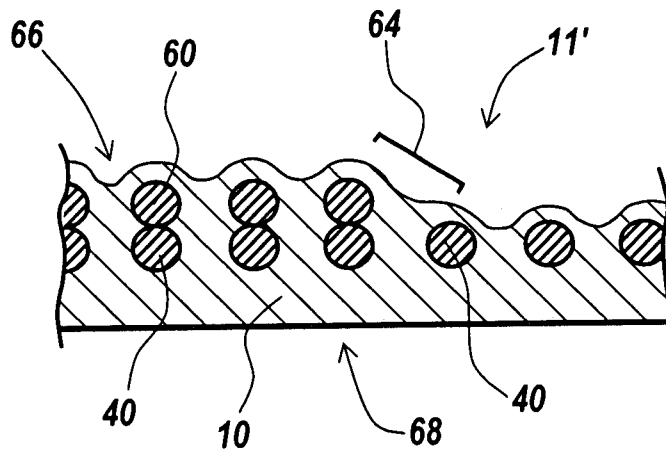
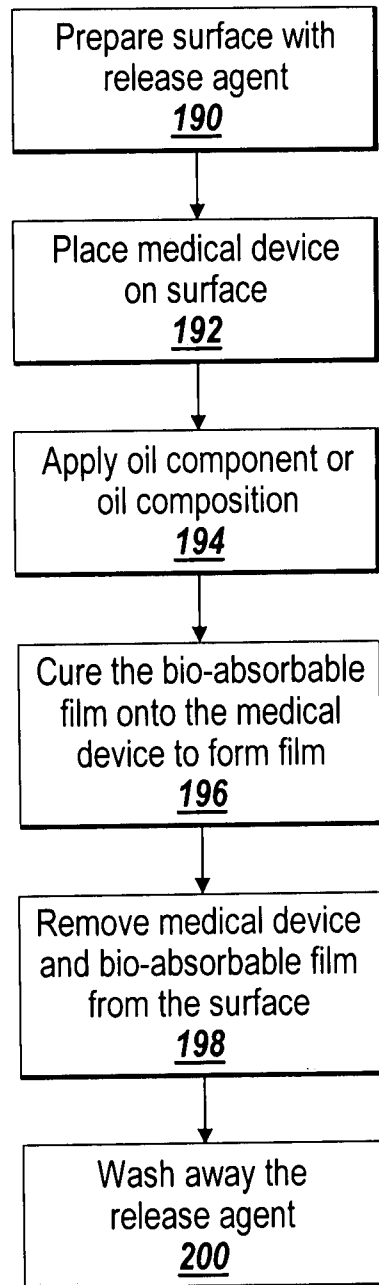

Fig. 12

10/11

*Fig. 13*

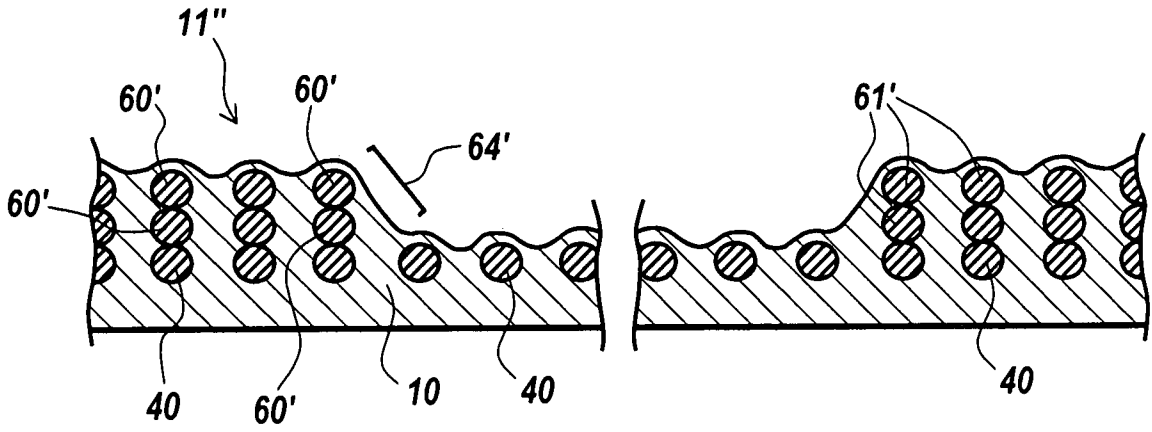

Fig. 14

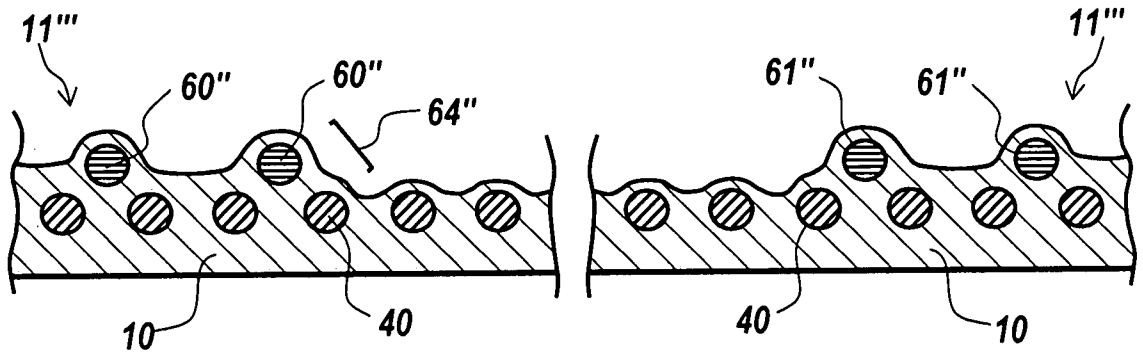

Fig. 15A

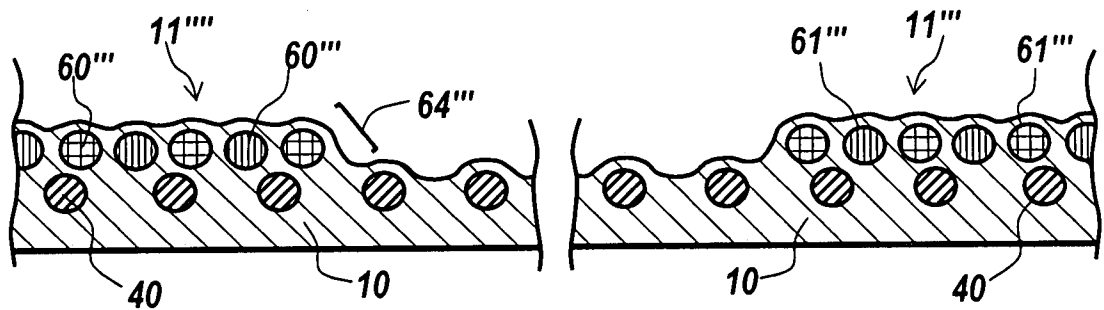

Fig. 15B