

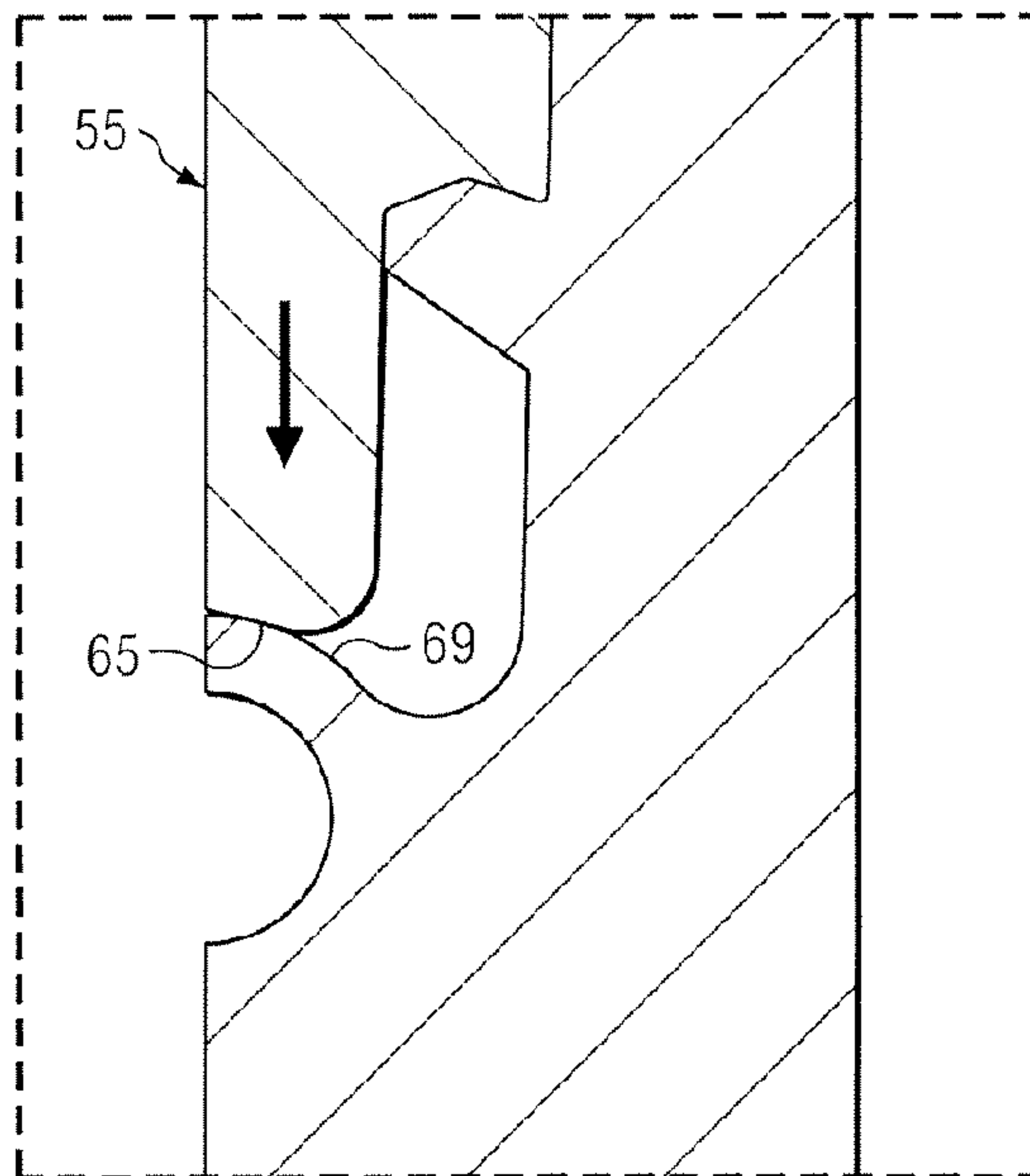

(86) Date de dépôt PCT/PCT Filing Date: 2010/10/20
 (87) Date publication PCT/PCT Publication Date: 2011/05/12
 (45) Date de délivrance/Issue Date: 2017/09/26
 (85) Entrée phase nationale/National Entry: 2012/05/09
 (86) N° demande PCT/PCT Application No.: US 2010/053372
 (87) N° publication PCT/PCT Publication No.: 2011/056429
 (30) Priorité/Priority: 2009/11/04 (US12/612,376)

(51) Cl.Int./Int.Cl. *F16L 15/04* (2006.01),
F16L 15/06 (2006.01)
 (72) Inventeur/Inventor:
LENG, KUO-TSUNG, US
 (73) Propriétaire/Owner:
GANDY TECHNOLOGIES CORPORATION, US
 (74) Agent: KIRBY EADES GALE BAKER

(54) Titre : RACCORD DE TUYAU FILETE A UN JOINT FLEXIBLE ACTIVE PAR PRESSION
 (54) Title: THREADED PIPE CONNECTION WITH A PRESSURE ENERGIZED FLEX-SEAL



(57) **Abrégé/Abstract:**

A threaded pipe connection is shown which features a pressure energized flex-seal structure. The connection includes a first box member having a box end, the box end having an end opening defining an interior surface with internal threads, the internal threads being defined by crests and roots and opposing flanks. A second, mating pin member has a pin end with a pin nose, the pin end having an exterior surface with mating external threads, the external threads also having crests and roots and opposing flanks, at least selected ones of which move into engagement with the internal threads of the box when the connection is made up. A flex-seal region is located on the box end interior surface which is designed to engage a cooperating energizing surface on the mating pin end to thereby form a primary containment seal upon make up of the connection.

(12) INTERNATIONAL APPLICATION PUBLISHED UNDER THE PATENT COOPERATION TREATY (PCT)

(19) World Intellectual Property Organization
International Bureau(43) International Publication Date
12 May 2011 (12.05.2011)(10) International Publication Number
WO 2011/056429 A1(51) International Patent Classification:
F16L 15/04 (2006.01)(21) International Application Number:
PCT/US2010/053372(22) International Filing Date:
20 October 2010 (20.10.2010)

(25) Filing Language: English

(26) Publication Language: English

(30) Priority Data:
12/612,376 4 November 2009 (04.11.2009) US(71) Applicant (for all designated States except US): **GANDY TECHNOLOGIES CORPORATION** [US/US]; 200 River Pointe Drive, Suite 110, Conroe, TX 77304 (US).

(72) Inventor; and

(75) Inventor/Applicant (for US only): **LENG, Kuo-Tsung** [US/US]; 2810 Pineleaf Drive, Sugar Land, TX 77479 (US).(74) Agent: **GUNTER, Charles, D.**; Whitaker, Chalk, Swindle & Sawyer, LLP, 301 Commerce Street, Suite 3500, Fort Worth, TX 76102-4186 (US).

(81) Designated States (unless otherwise indicated, for every kind of national protection available): AE, AG, AL, AM, AO, AT, AU, AZ, BA, BB, BG, BH, BR, BW, BY, BZ, CA, CH, CL, CN, CO, CR, CU, CZ, DE, DK, DM, DO, DZ, EC, EE, EG, ES, FI, GB, GD, GE, GH, GM, GT, HN, HR, HU, ID, IL, IN, IS, JP, KE, KG, KM, KN, KP, KR, KZ, LA, LC, LK, LR, LS, LT, LU, LY, MA, MD, ME, MG, MK, MN, MW, MX, MY, MZ, NA, NG, NI, NO, NZ, OM, PE, PG, PH, PL, PT, RO, RS, RU, SC, SD, SE, SG, SK, SL, SM, ST, SV, SY, TH, TJ, TM, TN, TR, TT, TZ, UA, UG, US, UZ, VC, VN, ZA, ZM, ZW.

(84) Designated States (unless otherwise indicated, for every kind of regional protection available): ARIPO (BW, GH, GM, KE, LR, LS, MW, MZ, NA, SD, SL, SZ, TZ, UG, ZM, ZW), Eurasian (AM, AZ, BY, KG, KZ, MD, RU, TJ, TM), European (AL, AT, BE, BG, CH, CY, CZ, DE, DK, EE, ES, FI, FR, GB, GR, HR, HU, IE, IS, IT, LT, LU, LV, MC, MK, MT, NL, NO, PL, PT, RO, RS, SE, SI, SK, SM, TR), OAPI (BF, BJ, CF, CG, CI, CM, GA, GN, GQ, GW, ML, MR, NE, SN, TD, TG).

[Continued on next page]

(54) Title: THREADED PIPE CONNECTION WITH A PRESSURE ENERGIZED FLEX-SEAL

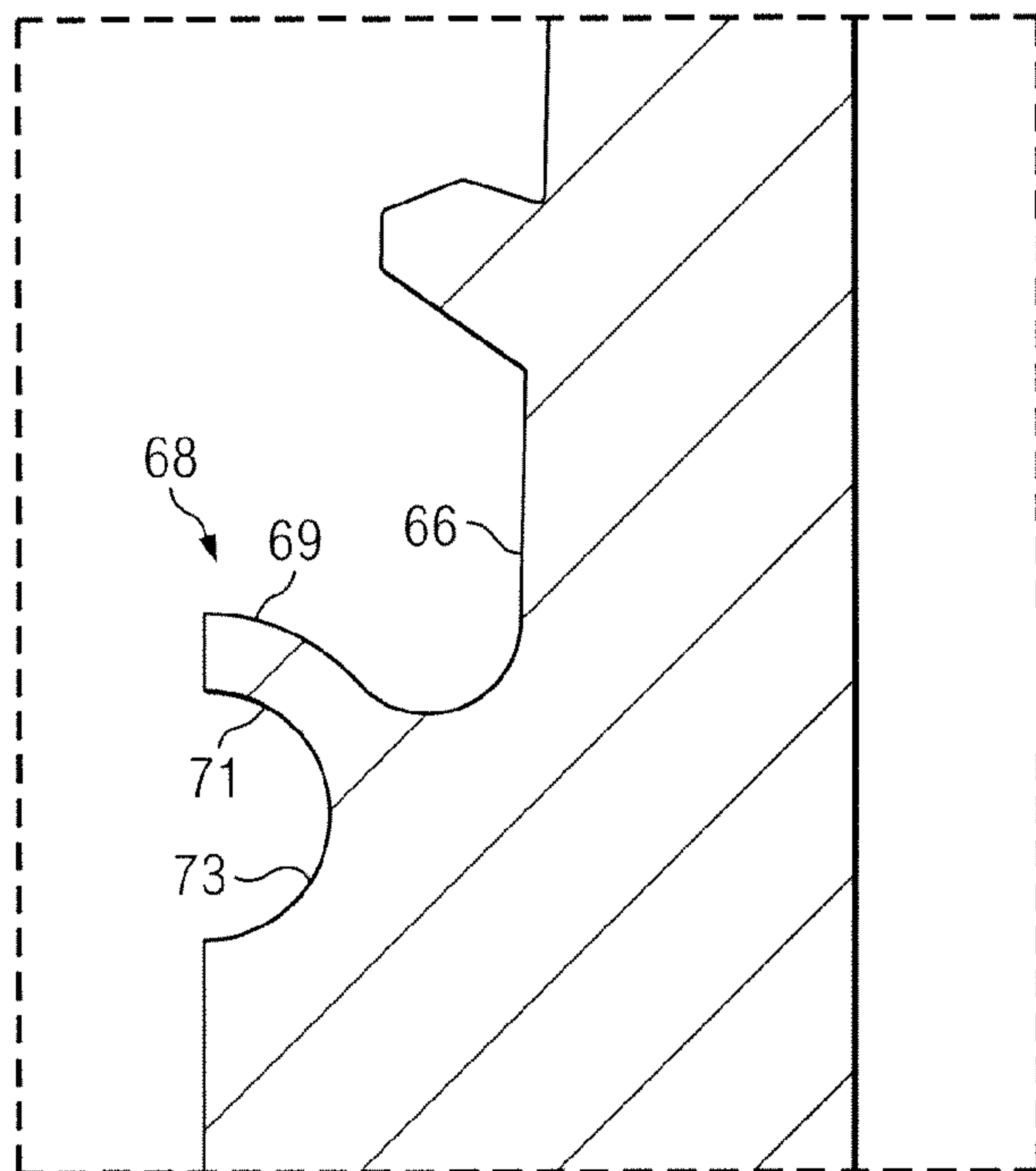

FIG. 6

(57) Abstract: A threaded pipe connection is shown which features a pressure energized flex-seal structure. The connection includes a first box member having a box end, the box end having an end opening defining an interior surface with internal threads, the internal threads being defined by crests and roots and opposing flanks. A second, mating pin member has a pin end with a pin nose, the pin end having an exterior surface with mating external threads, the external threads also having crests and roots and opposing flanks, at least selected ones of which move into engagement with the internal threads of the box when the connection is made up. A flex-seal region is located on the box end interior surface which is designed to engage a cooperating energizing surface on the mating pin end to thereby form a primary containment seal upon make up of the connection.

WO 2011/056429 A1

WO 2011/056429 A1 

Published:

— *with international search report (Art. 21(3))*

- 1 -

THREADED PIPE CONNECTION WITH A PRESSURE ENERGIZED FLEX-SEAL

Description

Technical Field

This invention relates generally to threaded tubular joints or connections and, more specifically, to a tubular joint for connecting the male or pin end of a pipe member to the female or box end of a pipe member in which a tapered radius seal surface provides a pressure energized seal for the connection.

Background Art

A variety of threaded connections are known in the prior art for joining tubular flow conduits in an end-to-end relationship to form a continuous flow path for transporting fluid. Typical examples of such flow conduits include casing, expandable casing, tubing, drill pipe and risers for oil, gas, water and waste disposal wells, and in horizontal and trenchless drilling applications. In the case of oil field casing and tubing, it is a common practice to use metal pipes of a definite length, with sections of pipe joined to form a string. The string of pipes effectively creates one lengthier pipe, intended to provide a means to reach the depth at which the reservoirs of gas or oil are found in order for extraction to the surface.

The pipe sections are secured together at their ends by an externally threaded connector, or "pin" that is threadedly received within an internally threaded connector or "box". Typically, each pipe section will have a pin on one pipe end and a box at the opposite pipe end. Some pipe has an internally threaded coupling secured to one end of a double pin pipe section to produce the box. The individual pipe sections are frequently referred to as a "pipe joint". Tubing and casing pipe joints are usually 30 ft. in length but can vary in length from 20 ft. to 40 ft. or longer.

The various pipe strings used in constructing a well are usually assembled on the floor of a drilling or workover rig. The pipe string is lengthened and lowered into the well as succeeding pipe joints are added to the string. During this assembly procedure, the pipe joint being added to the string is lowered, pin down or pin up, into an upwardly or downwardly facing box projecting from the drilling rig floor. This procedure is commonly referred to as "stabbing" the pin into the box. After being stabbed, the added pipe joint

- 2 -

is rotated to engage the threads of the pin and box, securing the joint to the string. The process is basically reversed in order to disassemble the pipe string. Once free of the box, the removed joint is moved to a storage location.

5 Oil and gas wells are currently being drilled which extend for thousands of feet into the surrounding subterranean formations. The connections for strings of drill pipe, tubing or casing must be able to withstand the total weight of a string of pipe many thousands of feet long. Since the drill string must also be used for the purpose of drilling, the joints must be able to withstand high torque loads, as well. Additionally, wells may not be
10 driven in exactly vertical fashion or even in straight line fashion. Horizontal oil and gas well drilling operations are common today. Other common horizontal drilling operations include the so-called "trenchless drilling" operations performed, for example, by municipalities for water and sewer line installations. This type of drilling places bending loads on the drill, casing or tubing strings at various places along the length thereof. In
15 other operations, sections of tubing or casing are sometimes driven into place, resulting in compressive loads being exerted. Thus, in addition to withstanding tremendous tensile loads, the threaded connections in the pipe string must also be able to absorb considerable compression loads.

20 The pipe strings of the type under consideration must have joints that provide a seal against leakage between mating threaded members. This can be achieved by providing a traditional metal-to-metal seal, upon make-up and a number of such designs exist in the prior art. With these types of seal systems, it is important that the mating sealing sections be free of defects or damage because, unless substantial surface-to-surface
25 contact is maintained, leakage will likely occur. Damage can occur, however, as during the assembling of the joints in that the components to be assembled are heavy and unwieldy. Thus, it is often too difficult to handle the pipe sections without damage, particularly as a new pipe section is being "stabbed" into a box or coupling. The result is that threads can be blemished and that sealing surfaces can be damaged.

30 Known prior art threaded connections used on oil field tubular goods often utilized a combination of specially designed "premium" threads and tapered (conical) sealing surfaces that engage to form a metal-to-metal seal to contain high pressures. The

- 3 -

premium threads often generated radial interference as a means for retaining the make-up torque of the connection and also to provide a secure seal. In some designs, a resilient seal ring was also included.

5 In order to contain high pressures, the radial interference of the prior art metal-to-metal conical sealing surfaces must be significantly greater than that of the threads to generate sufficient bearing stress to overcome the effect of machining tolerances and taper on the height of the threads most adjacent the seal and the effects of excessive pipe compound trapped in the threaded area. The presence of excessive metal-to-metal contact bearing stress at the conical sealing surfaces of the prior art containment seals often resulted in make-up damage, i.e., galling with the result that the sealing mechanism did not function reliably. More importantly, conical seals have a desirable nominal axial makeup position. Non-shouldered premium connections have critical diametrical tolerances and makeup torque restrictions to guarantee an axial makeup position so the conical seal does not accumulate excess or deficient diametrical interferences.

Known prior art designs also exist that combine a conical metal-to-metal seal with a wedge or other "hook" thread design as a torque stop. These type designs typically required a shallower angle for the metal-to-metal seal because of lenient axial tolerances required to machine the threads. In order to generate enough radial interference in the metal-to-metal seal to effect an efficient sealing mechanism, a great deal of rotation was required between initial contact of the sealing regions to final make-up. The longer the metal-to-metal seals were in contact during such rotation, the greater the tendency for galling. On the other hand, if interference was decreased to lessen the amount of rotational contact, sufficient contact forces were not always present to effect a reliable seal at final make-up.

Thus, despite the improvements in thread forms and seal structures for such thread forms discussed above, a need continues to exist for a thread form and associated seal arrangement which is capable of coupling tubular pipe sections quickly and efficiently, which forms a secure seal, which provides a more versatile design than existing designs, and which is economical to produce.

Disclosure of Invention

Certain embodiments provide a threaded connection characterized as having a pressure energized seal region capable of sealing both liquids and gases, the connection comprising: a first box member having a box end, the box end having
5 an end opening defining an interior surface with internal threads, the internal threads being defined by crests and roots and opposing flanks; a second, mating pin member having a pin end with a pin nose, the pin end having an exterior surface with mating external threads, the external threads also having crests and roots and opposing flanks, at least selected ones of which move into
10 engagement with the internal threads of the box when the connection is made up; a flex-seal region on the box end interior surface which is designed to engage a cooperating energizing surface on the mating pin end to thereby form a primary containment seal upon make up of the connection; and wherein the flex-seal region on the box end interior surface forms a tapered radius seal with the
15 cooperating pin nose; wherein the tapered radius seal on the box end interior surface, in cross section, comprises a circumferential lip ring which extends radially inward from the box root; wherein the lip ring includes an outer surface and a radially sloping interior surface, the pin nose making contact with the outer surface as the connection is made up; wherein a machined recess is located
20 behind the lip ring radially sloping interior surface in a location opposite the outer surface of the lip ring which provides a flexible property to the lip ring, whereby the lip ring forms a bendable region which acts like a spring upon contact with the pin nose when the pin nose contacts the lip ring outer surface; wherein the machined recess of the flex-seal region comprises a concave recess which is
25 shaped as a smoothly sloping arcuate surface which extends to and forms a portion of the lip ring radially sloping interior surface, and wherein any fluid present in the interior of the connection acts on the concave recess, thereby pressure energizing the flex-seal region during use; and wherein the threaded connection is a flush connection with the pin member outside diameter being the
30 same as the box member outside diameter.

- 4a -

Certain embodiments provide a further modification of the basic thread forms and associated seal structures discussed above which provides improved design characteristics and performance over the prior art.

5 Certain embodiments also provide a threaded pipe connection having an improved pressure containment seal which meets or exceeds the capabilities of presently available tapered or conical metal-to-metal containment seals.

10 The threaded connection of the disclosed embodiments has a unique pressure energized seal region which is capable of sealing both liquids and gases. The improved connection includes a first member having a box end, the box end having an end opening defining an interior surface with internal threads, the internal threads being defined by crests and roots and opposing flanks. The connection also includes a second, mating member having a pin end with a pin nose, the pin end having an exterior surface with mating external threads. The external threads of the pin member also have crests and roots and opposing flanks, at least selected ones
15 of which move into engagement with the internal threads of the box when the connection is made up. A special flex-seal region on the box end interior surface is designed to engage a cooperating energizing surface on the mating pin end to thereby form a primary containment seal upon make up of the connection. The flex-seal region on the box end interior surface forms a tapered radius seal with the
20 cooperating pin nose.

Preferably, the tapered radius seal on the box end interior surface, in cross section, comprises a lip ring region which extends radially inward from the box root. The lip ring region includes a radially sloping outer region and a radially sloping interior

- 4b -

region, the pin nose making contact with the radially sloping outer region as the connection is made up. In one preferred form of the invention, a concave recess is located behind the lip ring radially sloping interior region, whereby the lip ring region forms a bendable region which is flexible like a spring upon contact with the pin
5 nose.

Contact pressure between the pin nose and the lip ring region of the box interior is maintained within a controlled range due to the spring effect of the lip ring region of the

- 5 -

box end. The flex-seal region of the connection is an integral metal-to-metal seal located at one end of a box thread relief groove of the box member. The flex-seal region is intentionally located distant from the box end opening so that the seal is shielded from potential damage due to the pin during stabbing and make up of the connection. When
5 fluid is present in the interior of the connection during use, the fluid present acts on the concave recess which is located behind the lip ring radially sloping interior region, thereby further pressure energizing the flex-seal region. The connection can have mating threaded surfaces of a variety of conventional types which are selected, for example, from the group consisting of API 8 Round, API 10 Round and API Buttress
10 threads. The flex-seal feature of the invention can also be used with connections having a variety of premium threads.

Additional objects, features and advantages will be apparent in the written description which follows.

15

Brief Description of Drawings

Figure 1 is a partial, quarter-sectional view of the box end of a section of pipe showing a premium thread form used thereon.

20

Figure 2 is another quarter-sectional view of the thread form of Figure 1 but also showing the pin member which engages the box end to form a threaded connection.

Figure 3 is an isolated view of one thread of the box member of Figure 1, showing the relative geometry thereof.

25

Figure 4 is a view of the same thread form on a box member, the threads in this case being essentially mirror images of the threads on the box of Figure 1.

30

Figure 5 is a quarter-sectional view similar to Figure 2 of a threaded pipe connection of the invention showing the box end of the first pipe member and the pin end of the second, mating pipe member moving into engagement, the box member being provided with the novel flex-seal structure of the invention.

- 6 -

Figure 6 is a close-up view of the flex-seal region of the threaded connection of Figure 5.

Figure 7 is a view similar to Figure 5, but showing the pin and box members of the connection moving into engagement.

Figure 8 is a close-up, isolated view of the flex-seal region of the threaded connection of Figure 7 showing the completed engagement between the pin and box members of the connection.

Figure 9 is a quarter-sectional view, similar to Figure 7, but showing an alternative form of the flex-seal and showing the pin member engaging the box end to form a threaded connection.

Figure 10 is an isolated view of the flex-seal region of Figure 9, showing the relative geometry thereof.

Best Mode for Carrying Out the Invention

The flex-seal feature of the invention will now be described with reference to a particular type of thread form which Applicant refers to as the "arrow thread form." This particular thread form is described in greater detail in U.S. Publication Number 2011/0012349, entitled "Arrow-shaped Thread Form For Tubular Connections." However, as will be apparent to those skilled in the art, the flex-seal feature of the present invention could be applied to a variety of types of thread forms known in the prior art. For example, such threaded connections are known for joining flow conduits in an end-to-end relationship to form a continuous flow path for transporting fluid. As discussed above, such threaded connections are used in pipe strings employed for the production of hydrocarbons and other forms of energy from subsurface earth formations. The previously described examples of such pipe strings include drill pipe, well casing and production tubing, referred to herein as "oil field tubular goods." Other threaded connections which can utilize the seal structure of the invention are used in the horizontal/trenchless drilling fields. There are also other non-oil field applications associated with the construction industry which could utilize the containment seal of the invention, as well. All of these type goods employ threaded

- 7 -

connections of the type under consideration for connecting adjacent conduit sections or pipe joints.

There have been numerous advances in thread technology used in oil field applications in recent years. For example, the previously mentioned "wedge" threads are known having a thread form which provides an unusually strong connection while controlling the stress and strain in the connected pin and box members of the connection. Such thread forms typically feature mating helical threads which are tapered in thread width in opposite directions to provide wedge-like engagement of the opposing thread flanks to limit rotational make-up of the connection. While the containment seal structure of the invention can certainly be utilized with "wedge" and other premium connections, it is not limited to these more exotic forms. The principles of the invention make it well suited for use "standard" types of threaded connections, such as API 8 Round, API 10 Round, API buttress, as well as the premium connections such as the wedge thread connections.

Turning to Figure 1 of the drawings, there is shown a quarter, cross-sectional view of a box end of a section of tubular pipe, such as a section of oil field casing, employing a particular type of premium thread form, the section of pipe being designed generally as 11. Figure 2 of the drawings is a similar quarter, cross-sectional view, but showing the box end 11 being made up with a mating pin end 12 to form the threaded pipe connection. Premium thread forms of this general type can be applied to a wide variety of tubular goods. Typical applications could include, but are not limited to, oil and gas offshore and onshore sub surface casing, intermediate casing, production casing, expandable casing, work over tubing, production tubing, tiebacks, risers, pile driving casing, line pipe, drill pipe, TNT pipe, flush joints, HDD pipe, water well pipe, liners for constructions, mining pipe, and disposal wells. Also, those skilled in the art will understand that thread forms of this generally type can be used in a variety of known types of pipe connections, including connections which are swaged, expanded, upset or non-upset and can be tapered or "cylindrical", non-tapered connections. The thread forms can also be used in connections which are helically structured as wedge threads such as those described in U.S. Pat. No. 30,647 (Blöse) and U.S. Pat. No. 34,467 (Reeves).

- 8 -

Figure 3 shows one isolated thread from the box end of Figure 1 in section and in greater detail. As has been mentioned, the box end 11 of the tubular member has pin threads with thread crests 13 and thread roots 15. The crests 13 and roots 15 of the box member 11 are adapted to be made up with a mating pin member (illustrated as 12 in
5 Figure 2), having a complimentary thread structure. The pin end is essentially a mirror image of the box end. The box thread crests 13 are formed between a stab flank 17 and a load flank 19 of the pin thread (see Figure 3). The thread crests 13 are approximately parallel to the thread roots 15.

10 As used herein, the term "load flank" will be understood to designate that sidewall of a thread that faces away from the outer end from the respective male or female member on which the thread is formed, and the term "stab flank" will be understood to refer to that
15 sidewall surface that faces toward the outer end of the respective male or female member as the connection is made up. With respect to the thread shown in Figure 1, the box mouth or outer end would be located toward the top of the drawing.

As will be appreciated from Figures 1 and 2, the stab flanks 17 and load flanks 19 of the thread form are each designed to form a specially designed interfit between the two
20 mating thread surfaces of the pin end and box end of the threaded connection. This specially designed profile interfit is present on both the stab flank 17 and the load flank 19 of the threads making up the thread form. In the preferred form of the thread illustrated in Figures 1-3, the stab flanks 17 and load flanks 19 are each comprised of
25 only two facets, 21, 23 and 25, 27, respectively. It can also be seen from Figure 1 that the facets on the stab flanks 17 and the corresponding facets on the load flanks 19 of the thread form both lean in the same direction in imaginary parallel planes (illustrated as 27,
29 and 31, 33), so that the facets form an "arrow-shape" when viewed in profile.

It will be observed, with respect to Figure 3, that the facet 23 forms a negative angle or
30 "hook" with respect to the thread root 15 and to the horizontal axis of the pipe string (illustrated as 37 in Figure 2). By "negative" angle is meant that the angle formed between the facet 23 and the adjacent thread root surface 15 is an acute angle whereby the facet 23 flares or leans inwardly toward the thread root 15. In like fashion, the facet 21 forms a positive angle with respect to the surface 15. As will be appreciated with

- 9 -

respect to Figure 3, the facets 21 and 25 are all inclined in the same direction while the facets 23 and 27 are all inclined in the same direction. While in the preferred version of the thread form, the facets 21 and 25 are parallel and the facets 23 and 27 are parallel, it will be appreciated that the respective flanks could have facets which are not perfectly parallel, as well, as long as they continue to lean in the same general direction. It should also be noted that the unique profile interfit of the stab and load flanks of the thread form differs from, for example, a traditional "dovetail" thread. In the traditional dovetail thread, the stab and load flanks flare outwardly in opposite directions from the longitudinal axis of the pipe and from the thread roots. The thread crests of the traditional dovetail are also wider than the width of the thread at the thread roots. In the case of the present thread form illustrated in Figure 3, however, the width of the thread root "w" is slightly greater than the width of the thread crest 13.

Each of the flanks of the thread form has a given thread height which is made up by the combined height of the two facets on the flank, illustrated as "h1" and "h2" in Figure 3. In the version of the thread form illustrated in Figure 3, the height of each thread flank 17, 19 is approximately equal. However, it will be appreciated that, in other versions of the thread form, the facet heights may differ. For example, the facet height of one of the stab or load flank facets adjacent the thread roots can be greater than the remaining facet heights of the particular thread.

As was briefly mentioned, thread forms of the type under consideration can either be cylindrical threads, or can be tapered threads having a given angle of taper with respect to a longitudinal axis of the pipe. In the engaged connection shown in Figure 2, the thread crests and roots are on an imaginary axis 35 which is parallel to the longitudinal axis 37 of the pipe.

As has been briefly described, in some cases, the thread forms can be helically structured as a wedge. In other words, both the pin and box threads are machined as helical wedge threads and thus have progressively changing axial width along the helical length thereof. In other words, with reference to Figure 2, the threads on the pin member 12 could be machined so that the thread width of each successive thread progressively decreases from the inner extent of the pin member along the helical length thereof to the

- 10 -

outer extent adjacent the mouth of the pin member. The axial thread width of the box member would progressively decrease in the opposite direction. The progressively changing axial width of the pin and box threads provides a wedging interfit to limit axial make-up of the tubular connection. Further details of "wedge" thread forms can be
5 gained from the previously referenced U.S. Pat. No. 30,647, and similar references which will be familiar to those skilled in the art of thread form design.

Figure 4 of the drawings illustrates another version of the premium thread form under consideration, which will be referred to herein as the "reverse arrow-shape profile." The
10 thread form shown in Figure 4 is again a box member 39 having external threads with stab flanks 41 and load flanks 43 and flat crests 45 and roots 47 for mating with the mating internal threads of a pin to make up a pipe connection. In the form of the invention illustrated in Figure 4, however, the facets making up the stab flanks 41 and
15 load flanks 43 are each facing exactly oppositely in direction from the facets in the thread form of Figure 3 so that the thread flanks form a "reverse arrow-shape" in profile. In other words, with reference to Figure 4, the reverse arrow-shape profile is essentially the opposite or mirror image of the regular arrow-shaped profile which has been discussed up to this point. However, in common with the first form of the thread which has been
20 described, the "reverse arrow-shape" profile of Figure 4 has stab and load flanks which are made up of only two facets, such as the facets 49 and 51. The facets 49 and 51 also lean in different directions, as was true in the cases of facets 21, 23 and 25, 27 in Figure 3. The thread form of Figure 4 differs from the regular arrow-shaped profile of Figures 1-3 in that the threads are formed with a positively sloped facet 53 at the root of the load flank.

25 The assembly of a typical connection will be briefly discussed with respect to Figures 1 and 2 of the drawings. As has been explained, assembly of the pipe string normally involves a pipe joint being added to the existing string by lowering a section of pipe pin end down, into an upwardly facing box projecting from the drilling rig floor. After being
30 stabbed into position, the added pipe joint is rotated to engage the threads of the pin and box, thereby securing the joint to the pipe string. The connections of the invention are generally free-running with the respective thread roots and crests, i.e., 13, 15 in Figure 2, first making contact. Next in the order of assembly, the facet surfaces 21 and 25 make

contact with their respective counterparts in the pin end. Finally, the facet surfaces 23 and 27 make contact with their respective counterpart surfaces in the box end of the connection.

5 Figure 5 of the drawings illustrates the improved flex-seal structure of the present invention as applied to a connection having the previously described premium thread form. The actual thread form illustrated in Figure 5 is identical to that described with respect to Figure 4 above. Figure 5 actually shows the beginning assembly or stabbing
 10 in of the pin member 55 into the box member 57. The box member 57 which is illustrated in Figure 5 again has a box end with an end opening (generally at 59) which defines an interior surface with internal threads. The threads are again defined by crests 61 and roots 63 as well as by the respective opposing flanks. The pin member 55 has a pin end with a pin nose 65. The pin end has an exterior surface with mating external threads which also have thread crests and roots and opposing flanks, at least selected ones of
 15 which move into engagement with the internal threads of the box member 57 when the connection is made up.

In the case of the connection illustrated in Figure 5, the box member 57 has a special flex-seal region, designated generally as 67, which is illustrated in close-up fashion in
 20 Figure 6. The flex-seal region 67 is designed to engage a cooperating energizing surface on the mating pin member 55 to thereby form a primary containment seal upon make up of the connection. The cooperating energizing surface can be seen to be the pin nose 65, as will be apparent from Figures 7 and 8 which show the further steps in the make up assembly of the connection. As will be apparent in the description which follows, the
 25 flex-seal region of the connection is an integral metal-to-metal seal located at an inner extent of the internally threaded surface of the box end of the connection. As can be seen from Figure 6, the flex-seal region is preferably located adjacent a box thread relief groove (66 in Figure 6) of the box member. The flex-seal is located distant from the box end opening 59 so that the seal is shielded from potential damage due to the pin 55
 30 during stabbing and make up of the connection.

The flex-seal region 67 actually comprises a tapered radius seal with the cooperating pin nose 65. With reference to Figure 6, by "tapered radius seal" is meant the convex curved

- 12 -

lip region 68. Thus, as can be seen in Figure 6, the tapered radius seal region on the box end interior surface, in cross section, comprises a circumferential lip ring region which extends radially inward from the box root 63 toward the central axis (37 in Figure 5) of the connection.

5

As can be seen in Figure 6, the lip ring region 68 includes a radially sloping outer region 69 and a radially sloping interior region 71. As shown in Figures 7 and 8, the pin nose 65 makes contact with the radially sloping outer region 69 as the connection is made up. As will be apparent from Figure 6, some material has been machined away behind the convex curved lip region 68. The machined region forms a concave recess (73 in Figure 6) which is located behind the lip ring radially sloping interior region 71, whereby the lip ring region forms a bendable region which is flexible like a spring upon contact with the pin nose 65. Contact pressure between the pin nose 65 and the lip ring region of the box interior is maintained within a controlled range due to the spring effect of the lip ring region of the box end.

10

15

It will also be apparent from Figures 5-8 that any fluid present in the interior of the connection acts on the concave recess (73 in Figure 6) which is located behind the lip ring radially sloping interior region, thereby pressure energizing the flex-seal region during use. Thus, there are two complimentary forces at work on the flex-seal region of the connection in use. First of all, the lip ring region 68 is flexible like a spring due to the fact that some of the material is removed to form the recess 73. As a result, the lip region 68 is not rigid, but rather can deflect upon contact with the pin nose 65. The second force acting upon the flex-seal region is caused by internal fluid pressure within the interior of the connection acting upon the recess region 73.

20

25

As a result, besides functioning mechanically as a spring-like element, the flex-seal is also a fluid pressure energized seal mechanism. The supporting area of the seal is less than the contact region between the pin nose 65 and the surface 69 which pressure is acting upon. The supporting bearing pressure will increase at a rate higher than the internal pressure, thus providing a positively energized seal. The make up of the connection provides the initial bearing pressure at the flex-seal region that will assure the further energized seal mechanism once the internal pressure is acting upon the seal

30

- 13 -

region. In fact, the pressure acting upon the components of the seal region can be altered by increasing or decreasing the depth of the concave recess 73.

Figure 9 illustrates another connection of the invention with a slightly different flex-seal region, designated generally as 75. Once again, the box member 77 has a special flex-seal region which is illustrated in close-up fashion in Figure 10. The flex-seal region 75 is designed to engage a cooperating energizing surface on the mating pin member 79 to thereby form a primary containment seal upon make up of the connection. In the case of the flex-seal region 75 illustrated in Figures 9 and 10, the pin nose 81 again contacts the radially sloping outer region 83 of the convex curved lip region 85 on the box member. Contact between these surfaces creates a first metal-to-metal seal located at an inner extent of the internally threaded surface of the box end of the connection. However, in this case, the box member has an additional land 87 located behind the recess 89 which also forms a metal-to-metal seal with the interior surface 91 of the pin nose. This, in effect, creates a double metal-to-metal seal configuration for the connection. The first seal region is formed between the outer extent of the pin nose and the convex curved lip region 85 of the box member while the second seal region is formed between the internal radial surface of the land 87 and the interior surface 91 of the pin nose.

Even though the connection of Figures 9 and 10 features a double metal-to-metal seal configuration, the remaining recess region (90 in Figure 10) continues to be acted upon by any fluid present in the interior of the connection to further energize the flex-seal region during use. Thus, there continue to be two complimentary forces at work on the flex-seal region of the connection in use. First of all, the lip ring region 85 is flexible like a spring due to the fact that some of the material is removed to form the recess 89. As a result, the lip region 85 is not rigid, but rather can deflect upon contact with the outer extent of the pin nose 81. The second force acting upon the flex-seal region is caused by internal fluid pressure within the interior of the connection acting upon the recess region 90.

An invention has been provided with several advantages. The lip seal region of the connection of the invention blocks the internal pressure at a strategic point so that any

- 14 -

tendency to leak, as well as the degree of pin and box thread separation is minimized. The lip seal is an integral metal-to-metal seal at the end of the box thread relief groove. The lip seal is intentionally located at the far back end of the connection so that it is shielded from potential damage due to the pin nose during the stabbing or make up operation. The lip seal needs only a very low interference at make-up to provide a positive energized seal capability. The lip seal is flexible so that it will not introduce a high stress on the pin nose section of the connection during make-up. This feature of the flex-seal provides positive sealing while decreasing the danger of a galling problem. Contact pressure between the pin nose and the box interior surface is controlled due to the spring-effect of the flex-seal region of the connection. The lip seal needs far less metal-to-metal contact traveling due to make-up and therefore is again less likely to have a galling problem. The lip seal is more leak resistant than certain of the prior art designs where any surface galling or impurity particles present on any of the compressed contact surfaces would downgrade the sealing ability of the structure in a conventional shrink fit metal-to-metal seal. The lip seal has the potential to expand the seal surface due to the flexible energized lip mechanism to a broader area and to thus minimize the leakage problem. In one version of the flex-seal configuration of the invention, a double metal-to-metal seal structure is provided.

While the invention has been shown in only two of its forms, it is not thus limited but is susceptible to various changes and modifications.

CLAIMS:

1. A threaded connection characterized as having a pressure energized seal
5 region capable of sealing both liquids and gases, the connection comprising:

a first box member having a box end, the box end having an end opening
defining an interior surface with internal threads, the internal threads being defined
by crests and roots and opposing flanks;

10 a second, mating pin member having a pin end with a pin nose, the pin end
having an exterior surface with mating external threads, the external threads also
having crests and roots and opposing flanks, at least selected ones of which move
into engagement with the internal threads of the box when the connection is made
up;

15 a flex-seal region on the box end interior surface which is designed to
engage a cooperating energizing surface on the mating pin end to thereby form a
primary containment seal upon make up of the connection;

and wherein the flex-seal region on the box end interior surface forms a
tapered radius seal with the cooperating pin nose;

20 wherein the tapered radius seal on the box end interior surface, in cross
section, comprises a circumferential lip ring which extends radially inward from the
box root;

wherein the lip ring includes an outer surface and a radially sloping interior
surface, the pin nose making contact with the outer surface as the connection is
made up;

25 wherein a machined recess is located behind the lip ring radially sloping
interior surface in a location opposite the outer surface of the lip ring which
provides a flexible property to the lip ring, whereby the lip ring forms a bendable
region which acts like a spring upon contact with the pin nose when the pin nose
contacts the lip ring outer surface;

wherein the machined recess of the flex-seal region comprises a concave recess which is shaped as a smoothly sloping arcuate surface which extends to and forms a portion of the lip ring radially sloping interior surface, and wherein any fluid present in the interior of the connection acts on the concave recess, thereby
5 pressure energizing the flex-seal region during use;

and wherein the threaded connection is a flush connection with the pin member outside diameter being the same as the box member outside diameter.

2. The threaded connection of Claim 1, wherein contact pressure between the
10 pin nose and the lip ring of the box interior surface is maintained within a controlled range due to the spring effect of the lip ring of the box end.

3. The threaded connection of Claim 2, wherein the flex-seal region of the connection is an integral metal-to-metal seal located at an inner extent of the box
15 end internal threads.

4. The threaded connection of Claim 3, wherein the flex-seal region is located distant from the end opening of the box member so that the seal is shielded from potential damage due to the pin during stabbing and make-up of the connection.

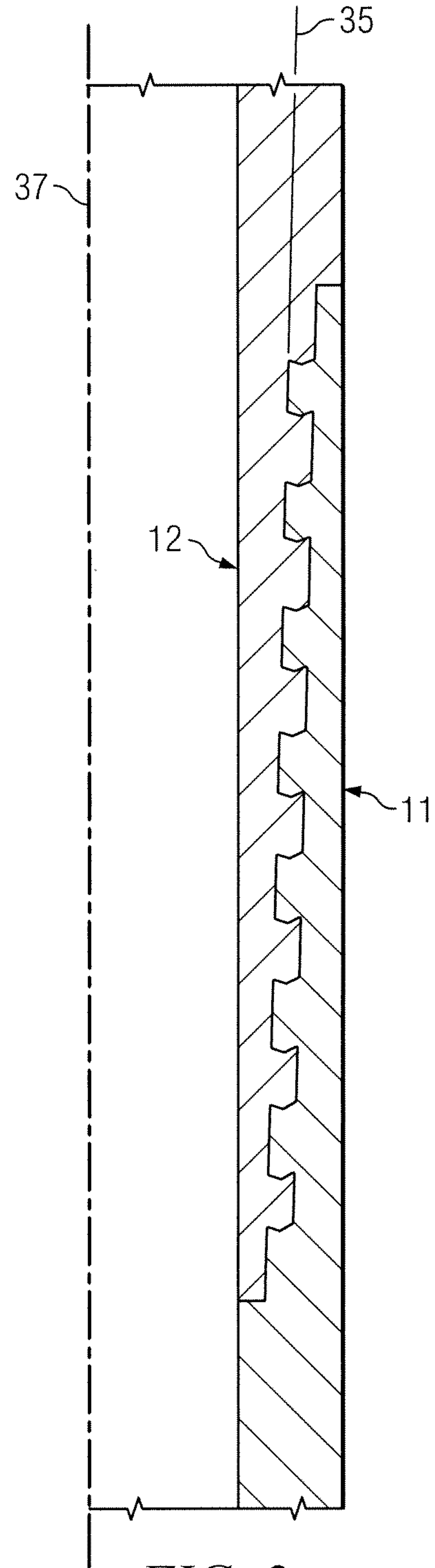
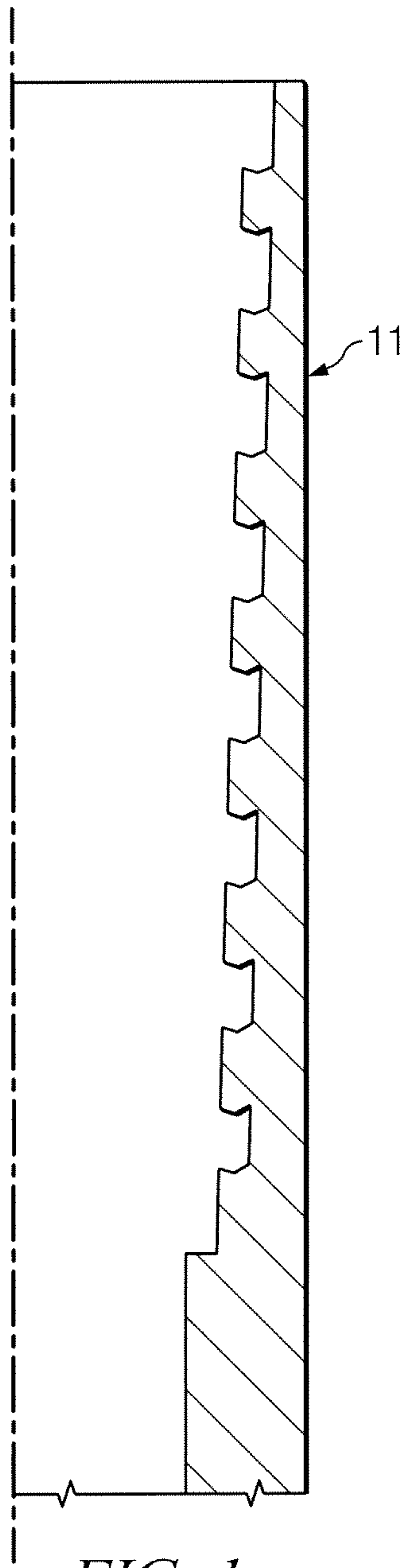

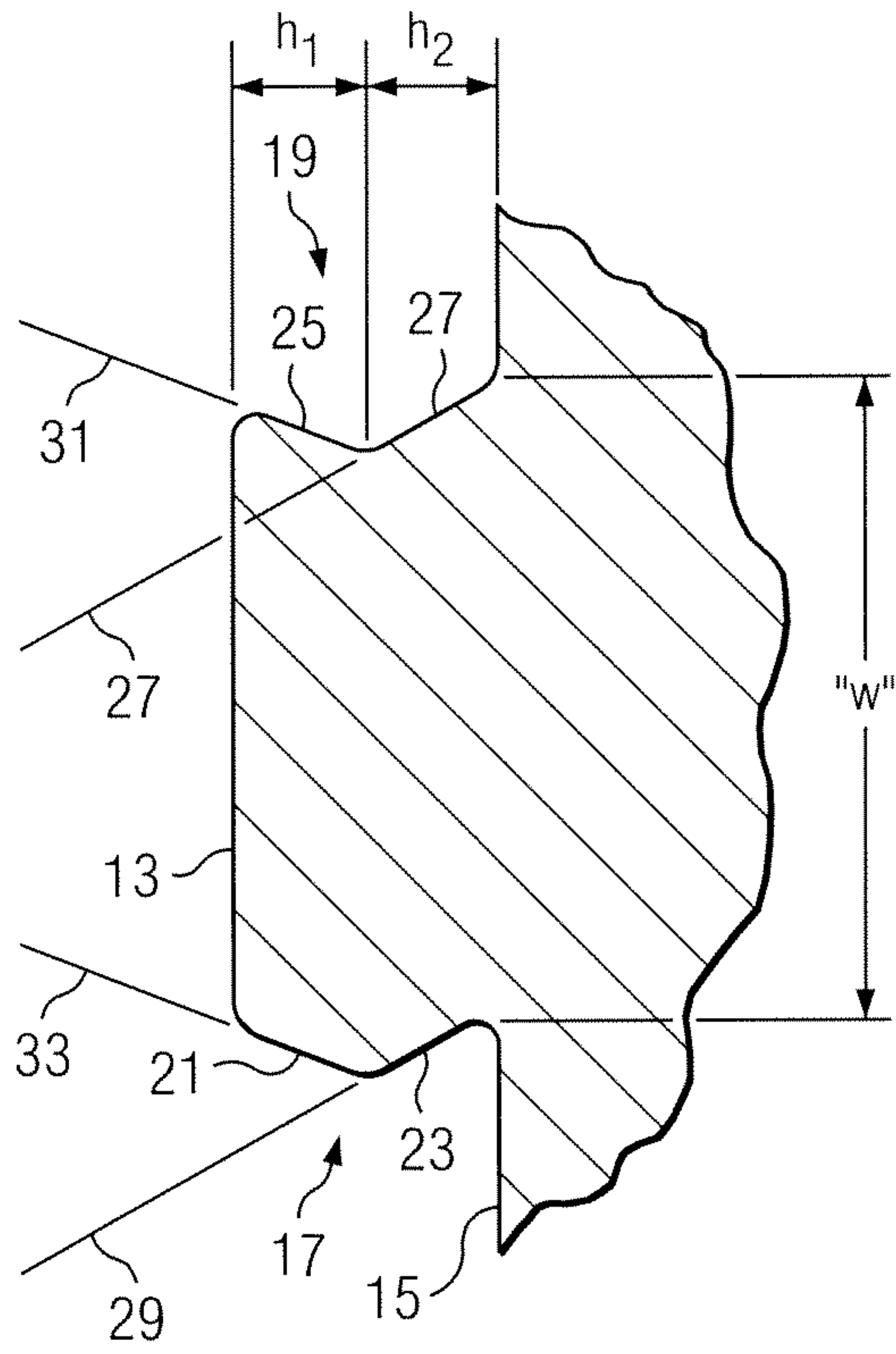

FIG. 3

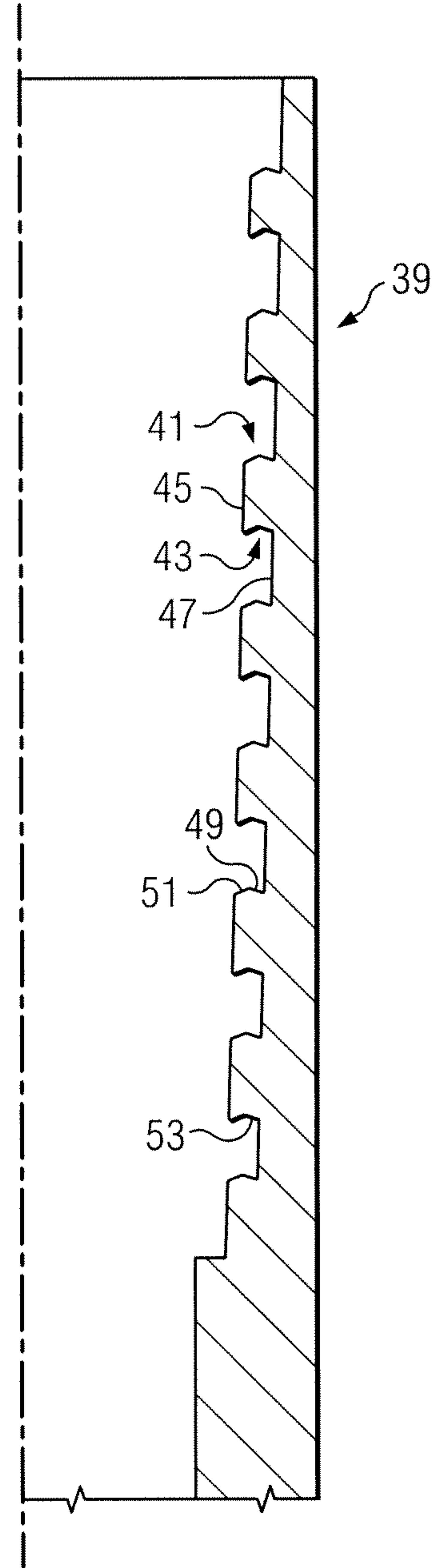
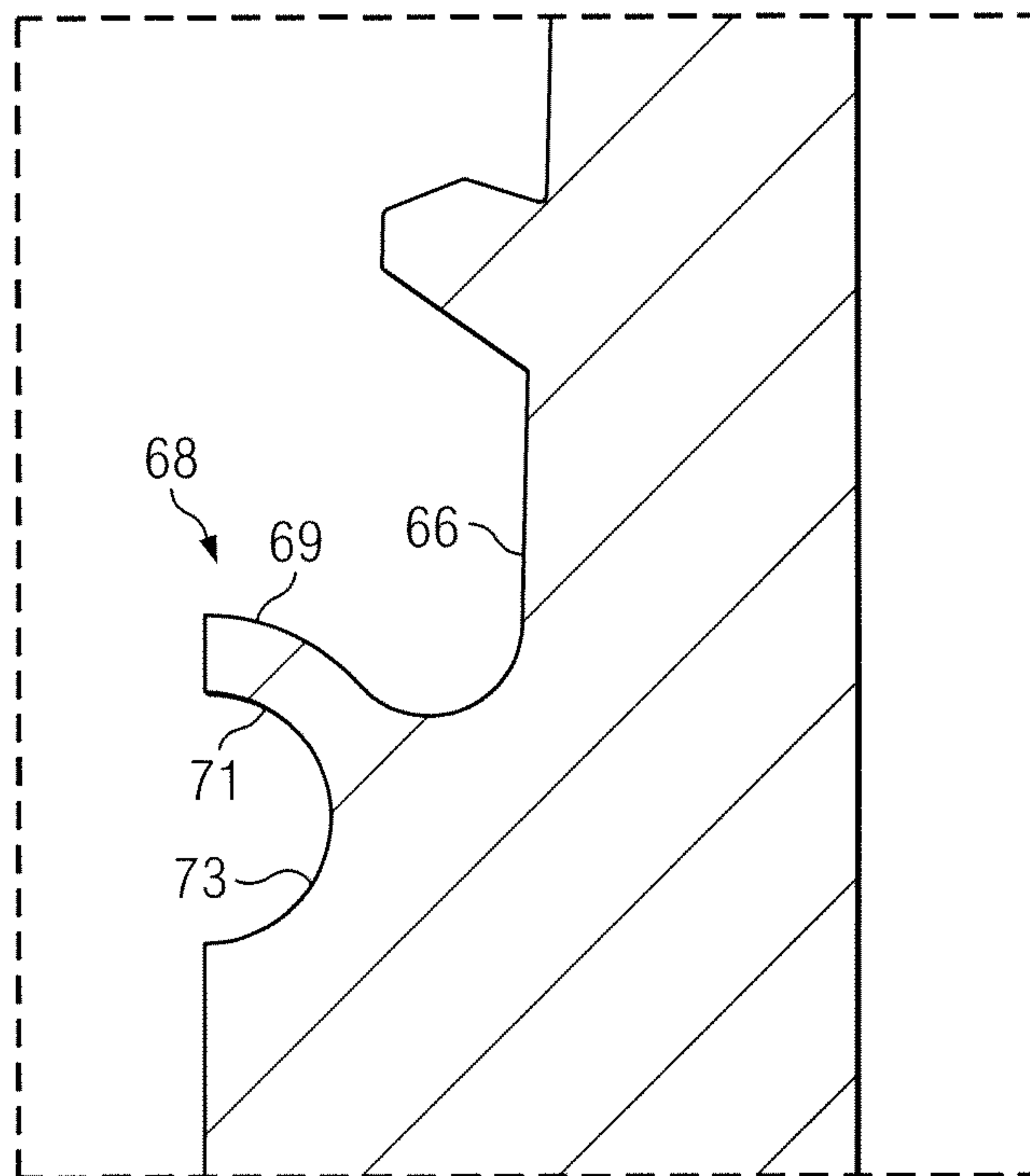
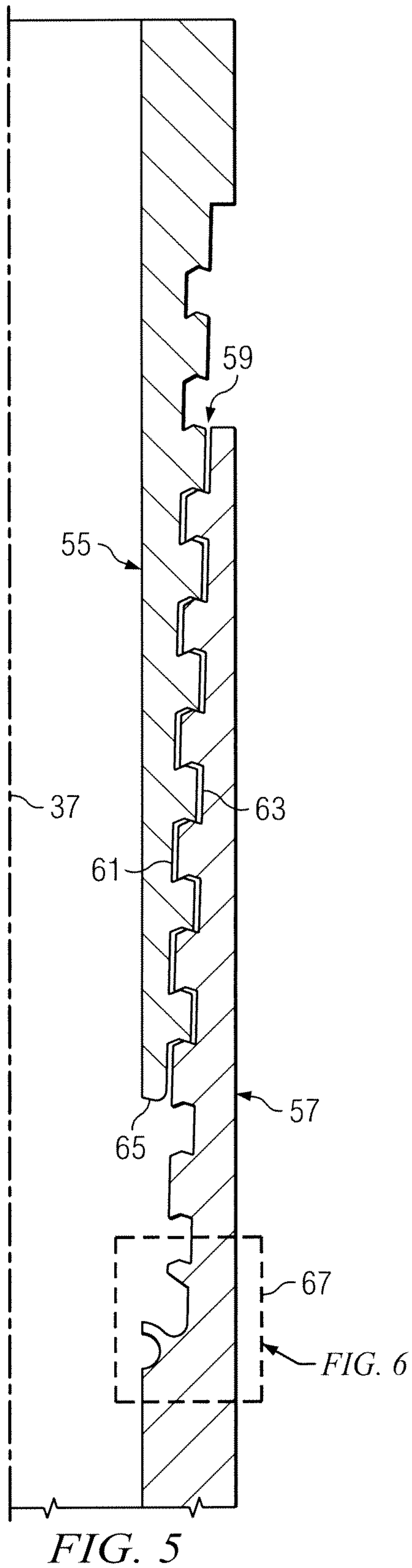
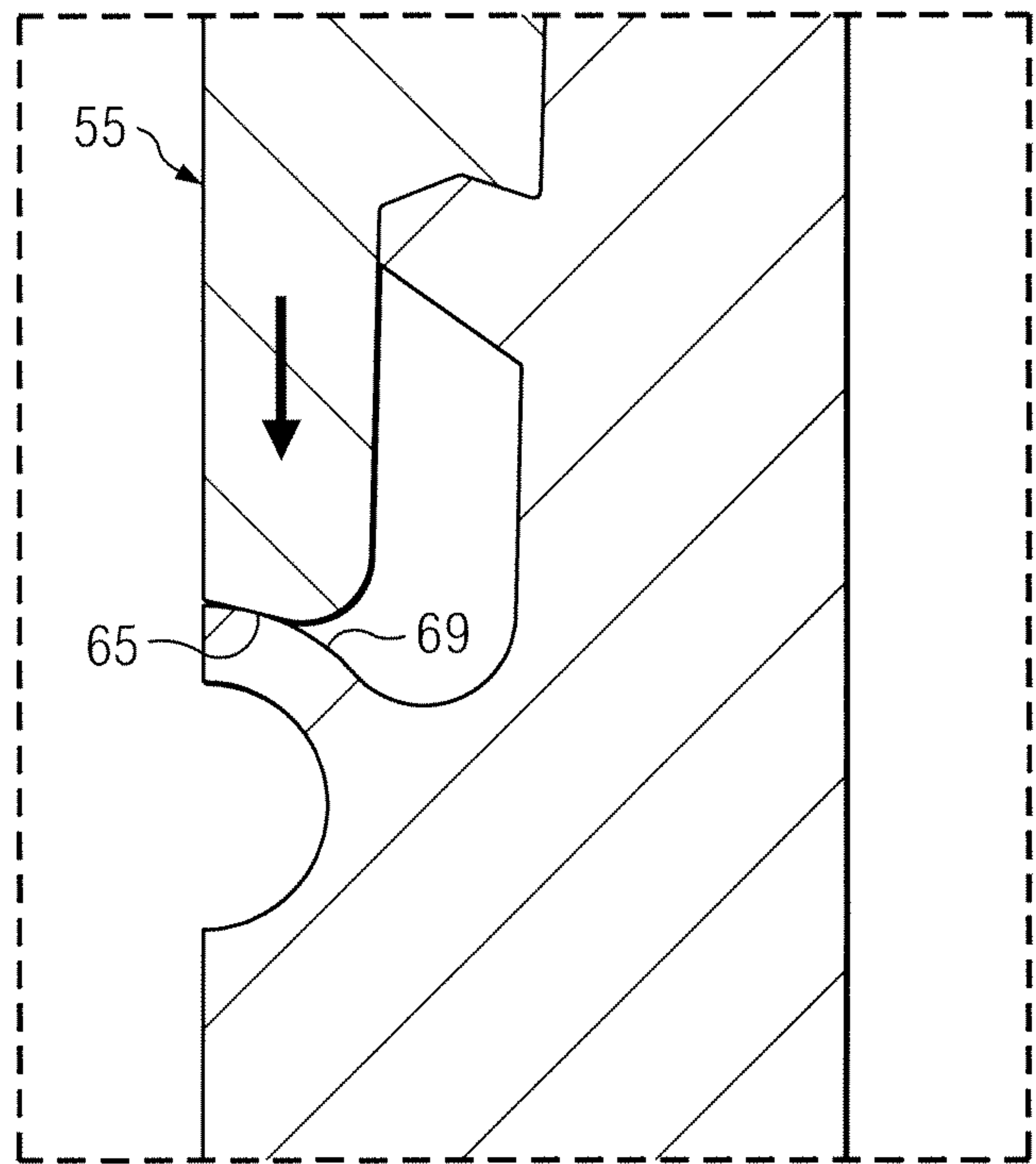
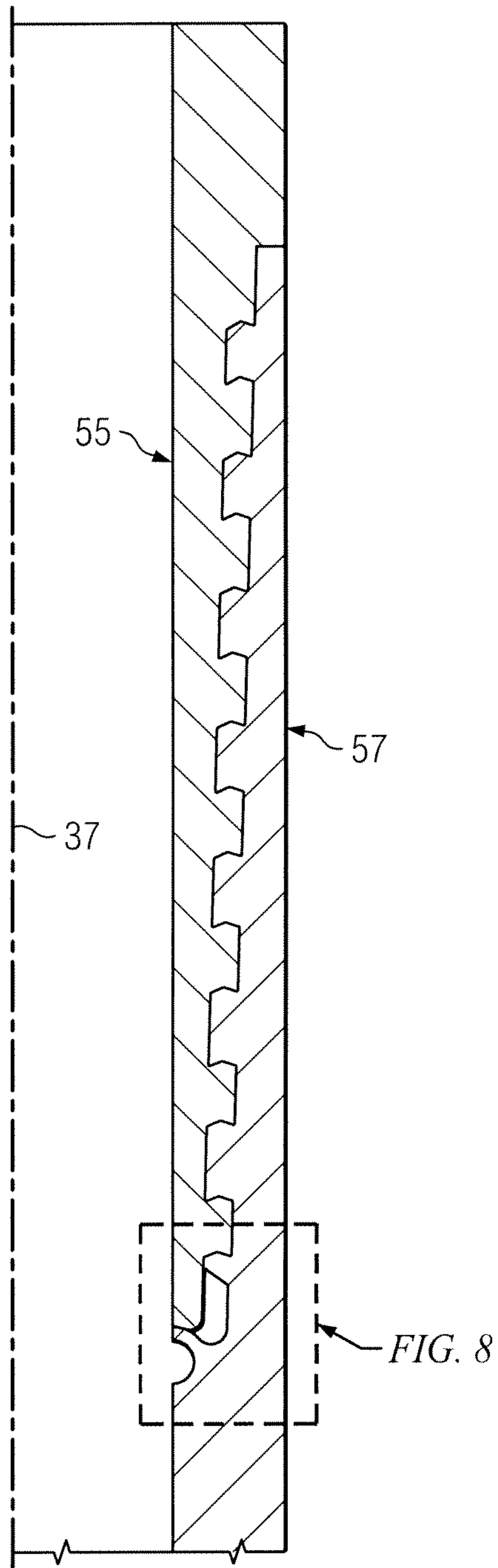

FIG. 4





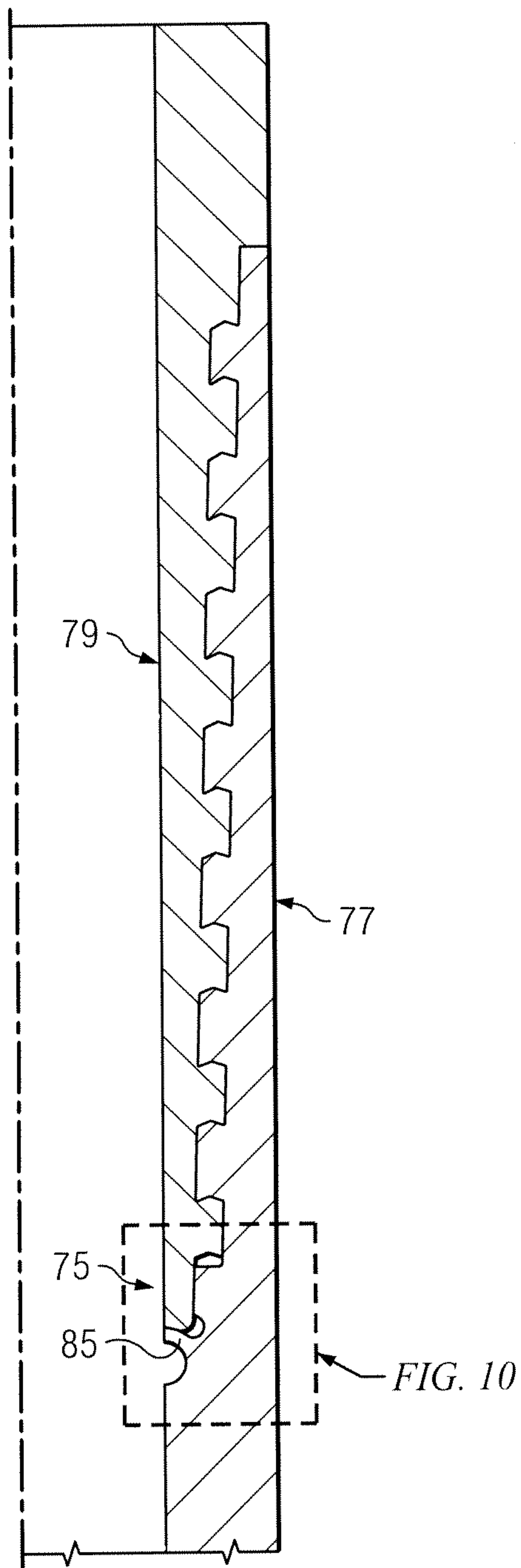

FIG. 9

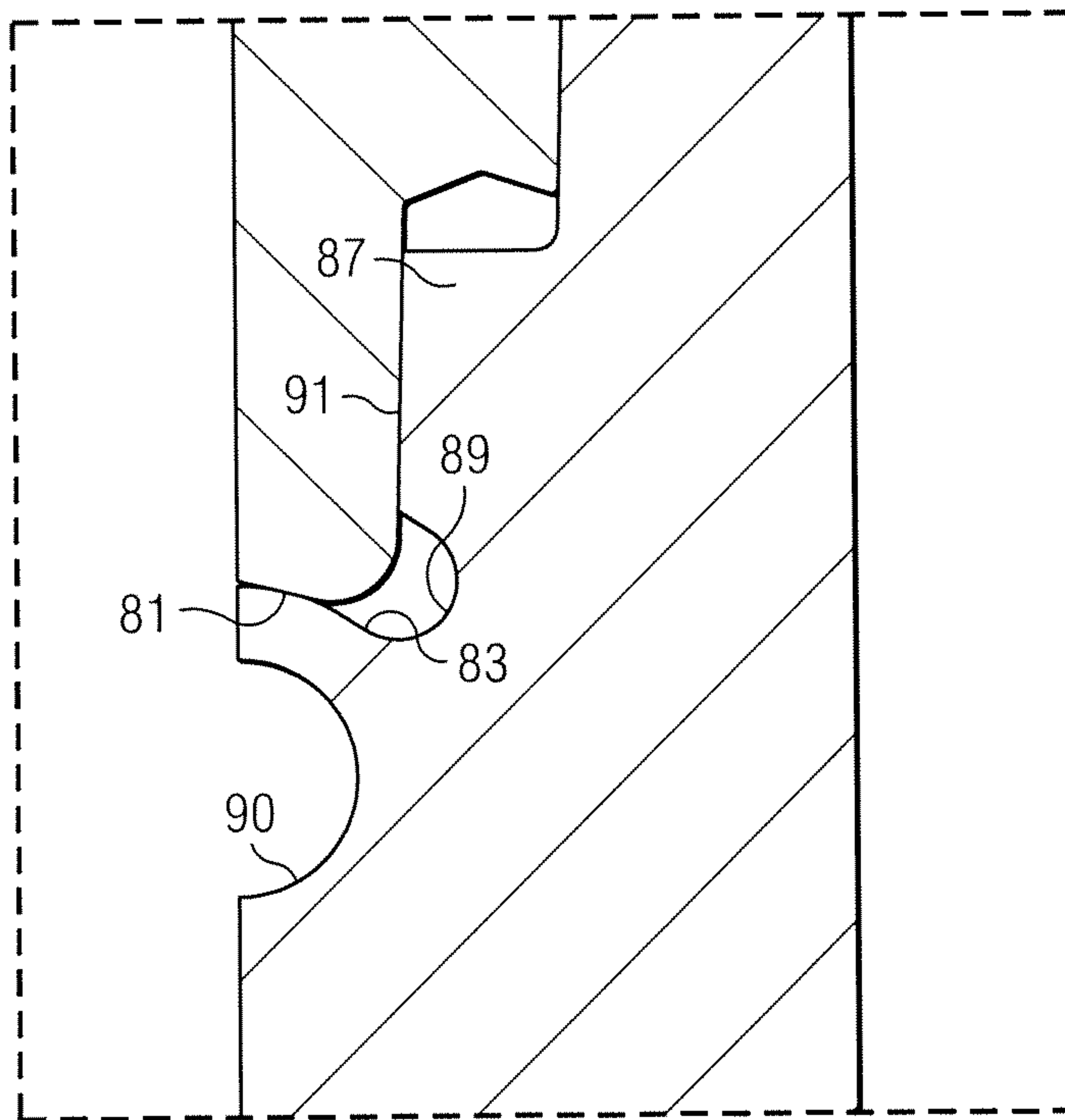

FIG. 10

