

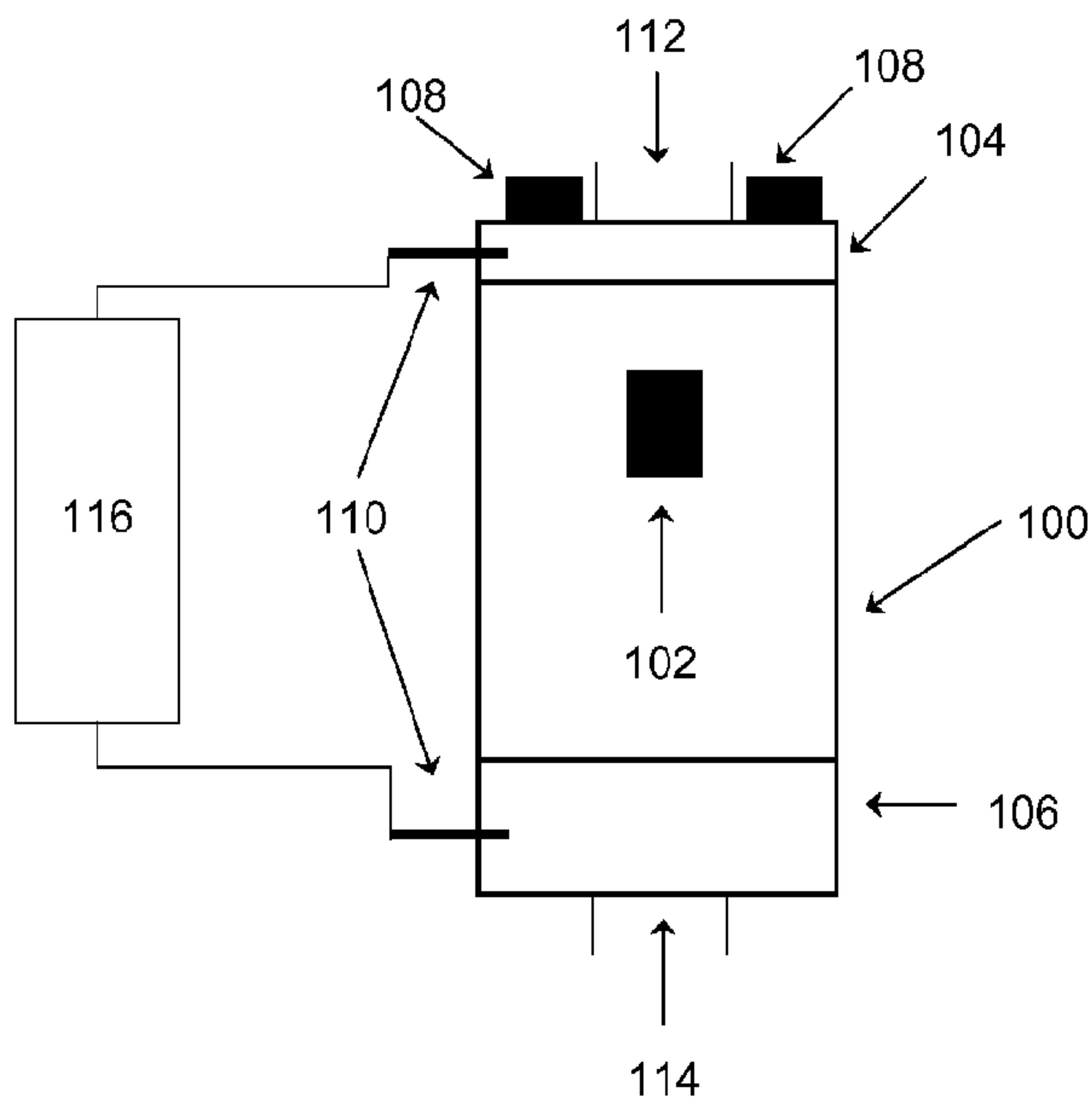

(86) Date de dépôt PCT/PCT Filing Date: 2011/06/08
 (87) Date publication PCT/PCT Publication Date: 2011/12/15
 (45) Date de délivrance/Issue Date: 2018/08/21
 (85) Entrée phase nationale/National Entry: 2012/12/04
 (86) N° demande PCT/PCT Application No.: US 2011/039609
 (87) N° publication PCT/PCT Publication No.: 2011/156477
 (30) Priorité/Priority: 2010/06/09 (US61/352,908)

(51) Cl.Int./Int.Cl. *B08B 7/02* (2006.01),
B01D 65/02 (2006.01), *B08B 5/04* (2006.01),
B60S 3/00 (2006.01), *B60S 5/00* (2006.01)
 (72) Inventeurs/Inventors:
 SAPPOK, ALEXANDER, US;
 BROMBERG, LESLIE, US
 (73) Propriétaire/Owner:
 FILTER SENSING TECHNOLOGIES, INC., US
 (74) Agent: DEETH WILLIAMS WALL LLP

(54) Titre : PROCÉDE ET SYSTÈME POUR ÉLIMINER LE RETENTAT DES FILTRES
 (54) Title: METHOD AND SYSTEM FOR REMOVING RETENTATE FROM FILTERS



(57) **Abrégé/Abstract:**

A cleaning system and method of cleaning filters that removes the ash in the plugged regions is disclosed. The filter is subjected to vibrations, which serve to loosen trapped and packed retentate from the filter. The loosened retentate is then captured by a collection bin. The cleaning system can be integral with the intended application, such as within an automobile. In another embodiment, the cleaning system is a separate cleaning station, where the filter is removing from its intended application, cleaned, and then reinstalled.

(12) INTERNATIONAL APPLICATION PUBLISHED UNDER THE PATENT COOPERATION TREATY (PCT)

(19) World Intellectual Property Organization
International Bureau(43) International Publication Date
15 December 2011 (15.12.2011)(10) International Publication Number
WO 2011/156477 A3

- (51) **International Patent Classification:**
B08B 7/02 (2006.01) **B01D 65/02** (2006.01)
B60S 3/00 (2006.01) **B08B 5/04** (2006.01)
B60S 5/00 (2006.01)
- (21) **International Application Number:**
PCT/US2011/039609
- (22) **International Filing Date:**
8 June 2011 (08.06.2011)
- (25) **Filing Language:** English
- (26) **Publication Language:** English
- (30) **Priority Data:**
61/352,908 9 June 2010 (09.06.2010) US
- (71) **Applicant (for all designated States except US):** **FILTER SENSING TECHNOLOGIES, INC.** [US/US]; 38 Second Street, Cambridge, Massachusetts 02141 (US).
- (72) **Inventors; and**
- (75) **Inventors/Applicants (for US only):** **SAPPOK, Alexander** [US/US]; 38 Second Street, Cambridge, Massachusetts 02141 (US). **BROMBERG, Leslie** [US/US]; 176 Wilshire Drive, Sharon, Massachusetts 02067 (US).
- (74) **Agents:** **NIELDS, LEMACK & FRAME, LLC** et al.; Suite 5, 176 E. Main St., Westborough, Massachusetts 01581 (US).
- (81) **Designated States (unless otherwise indicated, for every kind of national protection available):** AE, AG, AL, AM, AO, AT, AU, AZ, BA, BB, BG, BH, BR, BW, BY, BZ, CA, CH, CL, CN, CO, CR, CU, CZ, DE, DK, DM, DO, DZ, EC, EE, EG, ES, FI, GB, GD, GE, GH, GM, GT, HN, HR, HU, ID, IL, IN, IS, JP, KE, KG, KM, KN, KP, KR, KZ, LA, LC, LK, LR, LS, LT, LU, LY, MA, MD, ME, MG, MK, MN, MW, MX, MY, MZ, NA, NG, NI, NO, NZ, OM, PE, PG, PH, PL, PT, RO, RS, RU, SC, SD, SE, SG, SK, SL, SM, ST, SV, SY, TH, TJ, TM, TN, TR, TT, TZ, UA, UG, US, UZ, VC, VN, ZA, ZM, ZW.
- (84) **Designated States (unless otherwise indicated, for every kind of regional protection available):** ARIPO (BW, GH, GM, KE, LR, LS, MW, MZ, NA, SD, SL, SZ, TZ, UG, ZM, ZW), Eurasian (AM, AZ, BY, KG, KZ, MD, RU, TJ, TM), European (AL, AT, BE, BG, CH, CY, CZ, DE, DK, EE, ES, FI, FR, GB, GR, HR, HU, IE, IS, IT, LT, LU, LV, MC, MK, MT, NL, NO, PL, PT, RO, RS, SE, SI, SK, SM, TR), OAPI (BF, BJ, CF, CG, CI, CM, GA, GN, GQ, GW, ML, MR, NE, SN, TD, TG).

[Continued on next page]

(54) **Title:** METHOD AND SYSTEM FOR REMOVING RETENTATE FROM FILTERS

Figure 1.

(57) **Abstract:** A cleaning system and method of cleaning filters that removes the ash in the plugged regions is disclosed. The filter is subjected to vibrations, which serve to loosen trapped and packed retentate from the filter. The loosened retentate is then captured by a collection bin. The cleaning system can be integral with the intended application, such as within an automobile. In another embodiment, the cleaning system is a separate cleaning station, where the filter is removing from its intended application, cleaned, and then reinstalled.

WO 2011/156477 A3 

Published:

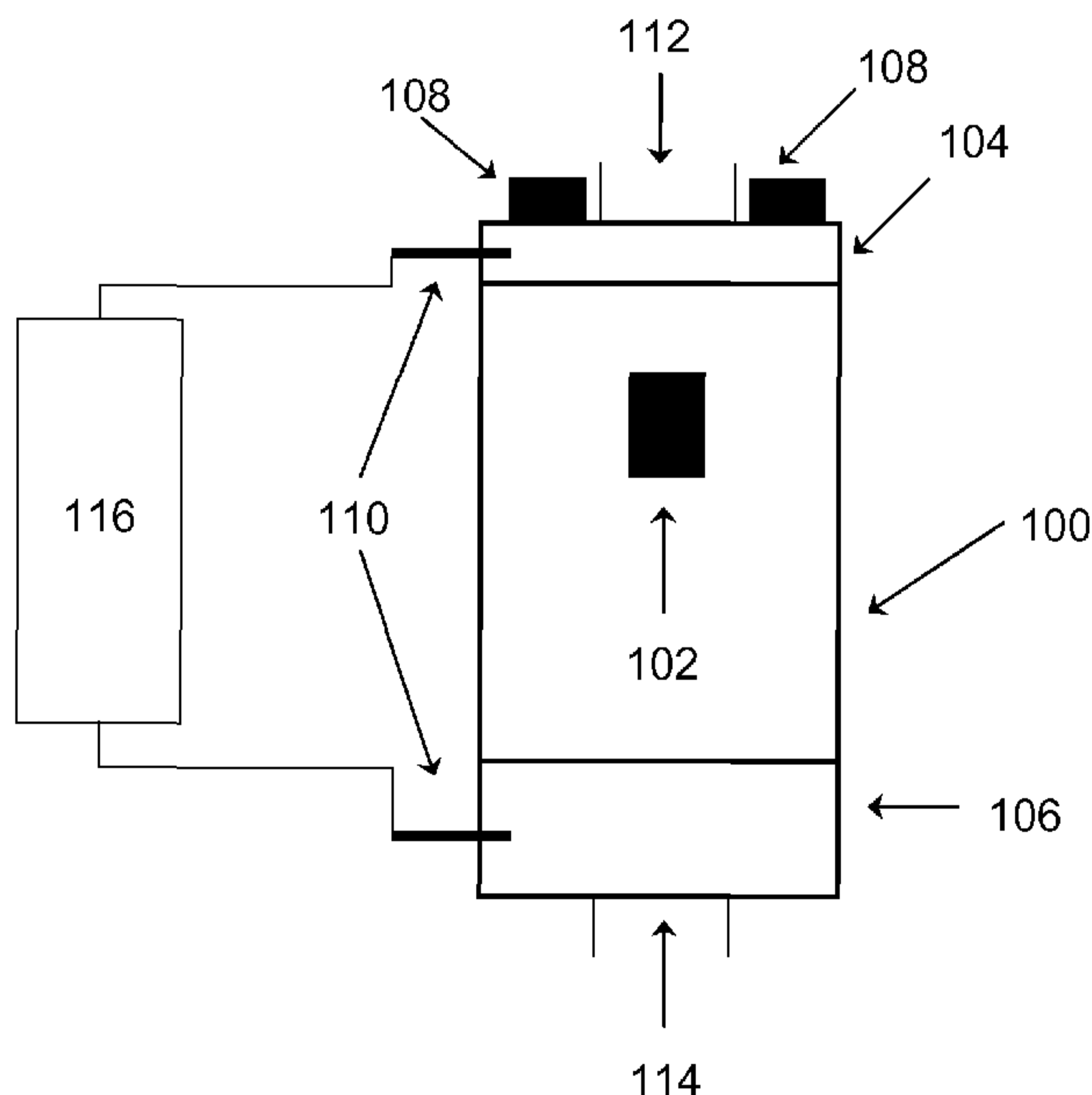
- *with international search report (Art. 21(3))*
- *before the expiration of the time limit for amending the claims and to be republished in the event of receipt of amendments (Rule 48.2(h))*

(88) Date of publication of the international search report:
29 March 2012

Method and System for Removing Retentate from Filters

BACKGROUND OF THE INVENTION

In many applications, there is a need to effectively and efficiently clean filters. In particular, there is a need to clean expensive filters, restoring them to a condition in which the filters can be reused. Additionally, many filters are difficult to clean using conventional means. A common method of cleaning filters uses forced air to blow off the retentate. There are a number of disadvantages to using forced air for filter cleaning.

First, forced air methods and systems generate airborne particles and dust that may pose health and environmental hazards. Many forced air cleaning systems require large and expensive secondary dust collection and filtration systems.

Second, forced air is not always effective at removing retentate from filters. In particular, filters with small pores, channels, pleats, or the like; or filters in which the retentate has become sintered, stuck, or otherwise adhered to itself or the filter surface may not effectively be cleaned by the use of forced air.

Third, forced air filter cleaning methods are ineffective at removing retentate packed in areas of the filter that experience little-to-no airflow.

Finally, ineffective filter cleaning reduces the useful life of the filter, and may cause efficiency losses or damage to the systems in which the improperly cleaned filters are used.

While there are many types of filters, diesel particulate filters, in particular, are especially difficult to clean using forced air. Diesel particulate filters are used to reduce soot emissions from a wide range of sources, including internal combustion engines. Although there are many types of diesel particulate filters, the most common are ceramic honeycomb-type wall-flow filters. These filters may be cordierite, silicon carbide, mullite, aluminum titanate, or any other suitable material. The wall-flow filters generally contain thousands of small channels, the walls of which are composed of a porous material. The ends of the channels may be alternately blocked at opposite ends of the filter (checkerboard pattern). Particulate-laden exhaust that enters the open end of a filter inlet channel is forced to flow through the porous filter walls to the adjacent outlet channel. The soot particles in the exhaust are trapped in the wall pores or in a cake layer along the channel surface.

In addition to ceramic wall-flow filters, a number of other diesel particulate filters exist including metal foam, sintered metal, and fiber-based (ceramic, glass, paper, and others) filters. These filters may contain pleats, channels, or a porous matrix, among other configurations.

Diesel particulate filters are effective at trapping in excess of 99% of engine-out soot in some cases. The trapped soot is periodically or continuously removed from the filter by regeneration. The regeneration process oxidizes the soot, but leaves incombustible ash behind.

Over time, the incombustible ash builds up in the filter, either in a layer along the filter walls, or in a plug at the back of the filter channels. Ash generally consists of metallic components, originating in lubricant additives, such as Mg, Ca, and Zn forming various sulfates, phosphates, and oxides. Trace metals in fuels (Na, K, Ca, and other elements found in biofuels for example) and engine wear metals and corrosion particles may also contribute. In cases where fuel-borne additives are used for filter regeneration, such as Ce, Fe, Pt, and others, these elements may also contribute significantly to ash accumulation in diesel particulate filters.

The build-up of ash restricts exhaust flow, increases exhaust backpressure, and negatively impacts engine fuel consumption. The ash further reduces the filter's soot storage capacity. In extreme cases, filter plugging can cause excessive exhaust backpressure leading to failure of the engine, exhaust, or machine system. One means of mitigating the negative effects of ash build-up on the filter and system (engine, vehicle, etc.) performance is to clean the filter, i.e., to remove the ash.

Common systems and methods employed to clean diesel particulate filters include forward and reverse blowing, through the use of forced air. Additionally, the filter may be heated (generally up to 650 C) to oxidize and remove soot as well. While filter heating is effective at removing the soot, it is relatively ineffective at removing ash at these temperatures.

One reason that diesel particulate filters are difficult to clean is due to the manner in which the ash accumulates in the filter, as well as its composition. Initially, beginning with a clean filter, the ash accumulates in a thin layer along the filter walls. This thin layer or membrane may actually provide a reduction in filter pressure drop

when the filter is also loaded with soot, as the ash layer may prevent soot from accumulating in the filter pores (depth filtration). Generally, the beneficial ash membrane is formed with less than 15 g/L specific ash loading, resulting in an ash layer that is on the order of 50 microns thick; however the pressure drop benefits may be realized with much thinner ash layers and lower specific ash loadings. Depending on the ash composition and properties, these values may differ, however.

As more ash accumulates in the filter, the pressure drop may increase significantly, such that any initial benefit is lost, and for a given level of soot load, the pressure drop across a particulate filter containing soot and ash is greater than the pressure drop across a filter containing the same amount of soot but no ash. Specific ash levels above 25 - 30 g/L may result in a significant increase in filter pressure drop, loss of soot storage capacity, as well as increase in regeneration frequency.

At these elevated ash levels, the majority of the ash (75% or more) may be packed toward the back of the filter, forming plugs in the filter channels. In some cases, for filters with 150,000 miles of on-road use, the ash may completely plug over 50% of the length of the DPF channels. The ash accumulated in the channel end-plugs may also pack, sinter, or fuse together or to the filter surface. As the ash accumulated in the plugs completely blocks the flow of exhaust through the ash-plugged region of the filter, it contributes significantly to filter pressure drop, generally more so than the porous ash accumulated in a thin layer along the filter walls.

Considering the ash distribution in the DPF, an ideal cleaning process is one that removes all of the ash from the plugs, but leaves a small thin layer along the channel walls. Removing the ash from the end plugs significantly

increases the available area for soot deposition, and reduces pressure drop. Leaving a thin layer of ash along the filter walls, preserves the beneficial effect of the ash membrane from preventing soot depth filtration, and provides some reduction in pressure drop.

Conventional forced air systems accomplish exactly the opposite of the ideal cleaning method proposed above. These systems and methods remove much of the ash in the layer along the channel walls (region of the DPF subject to highest flows), but are ineffective at removing ash in the plugged regions (most of the ash) of the filter which experience no, or negligible, flows.

Therefore, an improved cleaning system and method for use with filters, and particularly diesel particulate filters, is needed.

SUMMARY OF THE INVENTION

A cleaning system and method of cleaning filters that removes the ash in the plugged regions is disclosed. The filter is subjected to vibrations, which serve to loosen trapped and packed retentate from the filter. The loosened retentate is then captured by a collection bin. The cleaning system can be integral with the intended application, such as within an automobile. In another embodiment, the cleaning system is a separate cleaning station, where the filter is removing from its intended application, cleaned, and then reinstalled.

BRIEF DESCRIPTION OF THE FIGURES

FIG. 1 represents one embodiment of a filter cleaning system;

FIG. 2 represents a cross section of several channels in the filter of FIG. 1;

FIG. 3 represents a perspective view of one embodiment of the filter cleaning system;

FIG. 4 represents a filter cleaning station;

FIG. 5 represents a filter cleaning system integrated with a machine, such as a vehicle; and

FIG. 6 shows the requirements for a specific impulse of 0.1 m/s, for a mass of 70 kg.

DETAILED DESCRIPTION OF THE INVENTION

FIG. 1 depicts a vibration-based filter cleaning system according to one embodiment. A diesel particulate filter **100** is made up of a housing containing the filter element (not shown). The filter element may be of any type, but is generally a ceramic honeycomb contained within a metal housing or can. Together the filter element and housing form the diesel particulate filter **100**. The diesel particulate filter **100** may be removed from its application prior to cleaning. An end cap **104** is affixed to the filter outlet, and an ash collection bin **106** is affixed to the filter inlet. The end cap **104** and ash collection bin **106** may be affixed to the filter using conventional v-band clamps or other clamps commonly used in these applications, for example. One or more vibrating elements **102** may be attached to the filter housing **100**. Additional vibrating elements **108** may be attached to either or both end cap **104** and ash collection bin **106**. Additional vibrating elements **108** are shown attached to the end cap **104**.

The ash collection bin **106** may be a container of suitable composition, metal, plastic, composite material, or the like. In another embodiment the ash collection bin **106** may be a filter bag, plastic bag, or any other particle containment system affixed to the diesel particulate filter **100** inlet.

The vibrating elements **102**, **108** may be mechanically connected to one or more of the diesel particulate filter **100**, end cap **104** or ash collection bin **106**. In one example, the vibrating elements **108** may be bolted to the end cap **104** or ash collection bin **106** and the vibrating element **102** may be affixed to the diesel particulate filter **100** using a band clamp, such as a hose clamp.

The vibrating elements **102**, **108** may or may not contact the filter element directly. Filter end cap **104** and ash collection bin **106** may or may not be used. In another example, the filter end cap **104** is not used and the vibrating elements **108** may contact the filter element surface directly, such as the inlet or outlet surface. In this example, the vibrating elements **108** and **102** may be hand-held and manually pressed against the filter element surface or filter housing by the operator. The vibrating elements **108** and **102** may be held in place or moved along the diesel particulate filter **100** surfaces, including the outer housing and filter element surfaces.

In one embodiment, the vibrating elements **102**, **108** may be conventional vibrating motors, magnetostrictive elements, piezoelectric actuators, pneumatic vibrating elements, or any other device suitable for generating vibrations. Vibrating elements **102**, **108** may be supplied with power from an external supply or conventional electrical outlet, and may also be connected to a control system (not pictured). In another embodiment, the vibrating elements **102**, **108** may be ultrasonic or acoustic transducers. Additional couplant,

such as gel, water, or other suitable material may or may not be used to improve the transfer of vibration energy from the vibrating elements **102** and **108** to the diesel particulate filter **100**. The vibrations generated by vibrating elements **102**, **108** may be periodic or random, and continuous or pulsed.

The vibrating elements **102**, **108** may be affixed in any position or orientation relative to filter **100**. In one embodiment, the vibrating elements **102**, **108** may be adjusted (position optimized) to target regions of the filter with the highest ash deposits, such as the end-plugs. In many cases, the majority of the ash deposits are found as end-plugs in the back of the filter channels. Positioning the vibrating elements **102**, **108** close to the end plugs represents one means of specifically focusing the vibration energy on those regions of the filter **100** with the most accumulated ash. Prior to cleaning, the location and length of the ash deposits may be measured. Measuring the insertion length of a thin wire rod inserted down one or more diesel particulate filter **100** channels represents one means for determining the length of the ash plugs. Measurements of ash deposit location, although not required, may be used to determine the most appropriate location for the vibrating elements **102**, **108** to target the ash deposits.

The position of the vibrating elements **102**, **108** may or may not be altered or adjusted during the cleaning process. In one embodiment, the vibrating elements **102**, **108** may remain fixed during the cleaning process. In another embodiment, the position of the vibrating elements **102**, **108** may be continuously or intermittently adjusted during the cleaning process. In one example, vibrations are applied to a specific region of the filter **100** until no more ash is removed. The position of the vibrating elements **102**, **108** is then adjusted to focus the vibration energy on another

region of the filter **100** still containing ash deposits. Any range of vibrating frequencies and forces may be used. One or more vibrating elements **102**, **108** may be used.

In one embodiment, radio frequency-based filter soot and ash probes **110** may also be attached to the end cap **104** and ash collection bin **106** or the filter housing **100**. The filter housing **100**, end cap **104**, and ash collection bin **106** form a microwave cavity. The RF probes **110** may be connected to a control unit and power supply **116**. The RF probes **110** may be used to provide information on the amount of ash and soot in the filter as well as to detect filter failures, such as cracking or melting. Any frequency range of operation is suitable. Higher frequencies increase measurement spatial resolution. Measurements from the RF probes **110** may be used to determine when to clean the filter, and also when to stop cleaning the filter, in one example.

Additionally, in some embodiments, one or more connections **112** and **114** may be used. These connections may be part of the end cap **104**, the ash collection bin **106**, or both. The connections **112** and **114** may allow for the use of air flow, or any other suitable fluid flow to remove the retentate (ash/soot) dislodged by the vibrations. In another embodiment, a vacuum may be applied to at least one of these connections to remove the retentate. Air flow or vacuum is by no means required for system operation, but may be applied. Pressure transducers (not pictured) may also be used to monitor filter **100** pressure drop before, during, and after the cleaning process, to provide one measure of cleaning system effectiveness, and suitability for reuse of the cleaned filter.

The operation of the system shown in FIG. 1 will now be described. Vibrations and forces applied by vibrating elements **102**, **108** cause the ash deposits to break-up. In

one embodiment, low frequency vibrations, in conjunction with elevated forces, may be applied to break up the ash accumulated in the plugs. This may be followed by high frequency vibrations, but low applied forces, which may be used to cause the dislodged ash to fall out of the inlet section of filter **100** into the ash collection bin **106**. One particular method may utilize frequencies below 60 Hz to loosen and break up the ash deposits, and frequencies above 100 Hz to remove the ash from the filter **100**. In another embodiment, higher frequencies around 1 kHz may be used. The vibrations may be used to remove ash, soot, and any other contaminant material from the filter **100**.

The duration of the applied vibrations may be less than 10 minutes in one example. The applied frequencies and forces may be constant or variable. In another example, low frequency and high force vibrations are applied for 2 minutes followed by the application of high frequency and low force vibrations for another 2 minutes, and the process alternated over the entire cleaning duration, which may be 10 minutes. The duration of the applied vibrations may be any duration, and may be less than or greater than 10 minutes.

During the cleaning process, the location, orientation, and number of vibrating elements **102** and **108** may be varied or adjusted. The applied forces and vibrating frequencies may also be varied. In one example, the vibrations and forces may be varied by adjusting the voltage applied to a vibrating motor, or the internal weights on the motor shaft. In another example, simply placing absorbing material between the vibrating elements and filter (such as rubber matting or foam) may also damp the vibrations. In yet another example, the pressure and flow rate may be varied if pneumatic elements are used.

In one embodiment, the cleaning process may be monitored and controlled using the RF sensors **110**. In such a system, the cleaning process parameters (vibration, forces, and displacement) may be adjusted or optimized based on the measured rate of retentate removal. The filter **100** cleaning process may be stopped once filter **100** retentate is reduced to acceptable levels as determined by the RF sensors **110**. In another example, visual observations of the ash removal, mass of ash removed, or filter **100** pressure drop, may be used to determine when the cleaning process is finished, or to adjust process parameters. In yet another example, the cleaning process may be terminated when a certain predetermined time has elapsed. Any number of measurement systems and methods including x-ray, terahertz imaging, borescope inspection of the filter channels, and manual measurements of ash plug length using a wire rod may be used to determine ash levels in the filter **100** to adjust cleaning process parameters or determine when to stop filter **100** cleaning.

In another embodiment, the filter **100** may be first heated above 650 degrees C, preferably in the range of 700 to 1,000 degrees C. This heating may induce a volume change in the ash plugs, (expansion or shrinkage) which may facilitate their removal using vibrations. The heating may be accomplished using the existing filter regeneration system on the engine, or via external heaters or furnaces.

FIG. 2 provides additional details of the vibration cleaning process. A cross section of three channels of a diesel particulate filter **200** is shown. The figure shows the porous channel walls **202** an inlet channel **204** and accumulated ash **206** in a layer along the inlet channel walls and in a plug at the back of the channel. Two outlet channels **208** are also shown. Applied vibrations **210**, **212**, and **214** are schematically depicted.

The vibrations may be applied perpendicular to the channels as in **210** and **212** or parallel to the channels as in **214**, or at any angle or orientation to the channels and filter **200**. The orientation of the applied vibrations may or may not change during the cleaning operation. The vibrations may be induced on the channels or filter directly, or through the filter housing. The vibrations **210**, **212**, and **214** are used to break up, dislodge, and remove the ash or retentate **206** from the channels. In one embodiment, vibrations perpendicular to the channels **210** and **212** may be used to break up and loosen the ash plugs and deposits **206**. The loosened ash deposits may be removed from the channel **204** by application of parallel vibrations **214** causing the loosened ash to move down the channel **204** and fall out of the filter. Flows of air or other gases or liquids may or may not be used to aid in ash removal. Any orientation of the vibrations **210**, **212**, and **214** may be used in any sequence.

FIG. 3 presents a particular embodiment showing a particulate filter **300** to which an ash collection bin **302** and end cap **304** have been fixed. A vibrating motor **306** is mounted to the top of the end cap **304**. A vibrating collar **308** is also mounted around the circumference of the filter **300**. The vibrating collar **308** may contain one or more vibrating elements **310** such as magnetostrictive elements or other suitable elements. The position of the vibrating collar **308** may be adjusted during the cleaning process to target areas of the filter **300** containing high concentration regions of ash or ash that is difficult to remove, such as in the end plugs.

Although the vibrating elements **306** and **310** are shown mounted on the housing **300** or caps **304** externally to the filter element contained within housing **300**, the vibrating elements may be mounted directly on the filter element, such

as by placing the vibrating motor **306** directly on the face of the filter, in one example. In another example, the filter element may be removed from its housing **300** prior to application of the vibrations.

Application of vibrations from elements **306** and **310** cause the ash to be dislodged and fall into the ash collection bin or bag **302**. In this manner, no airborne ash dust is created.

FIG. 4 depicts an ash cleaning station. The station is comprised of a support structure **400**, isolating elements **406**, and a support surface **402**. One or more vibrating elements **408** are fixed to the support surface **402**. The vibrating elements **408** may be connected to a power supply and control unit (not shown). The support surface **402** is physically connected to the support structures **400** via isolating elements **406**, which serve to reduce the transfer of vibrations from support surface **402** to support structure **400**.

A filter fixture **404** may be connected to support surface **402**. The support fixture **404** allows a filter to be mounted in the horizontal or vertical direction, or any direction chosen by the operator. The support fixture **404** may or may not be used. In the event the fixture **404** is not used, the filter (not pictured) may be held in place manually by the operator, or some other means.

The vibrating element **408** is used to induce vibrations in the support surface **402** which are then transferred to the filter placed on the support surface **402**. The position of the filter on the support surface may be varied during the cleaning process. The filter placed on the support structure **402** may or may not contain an end cap **304** and an ash collection bin **302** as shown in FIG. 3. If the filter does not contain an end cap **304** or ash collection bin **302**,

an enclosure or ash collection bin or system may be mounted on support surface **402** to collect and contain the ash removed from the filter.

The vibrations induced on the filter placed on the support structure **402** by vibrating element **408** are used to loosen, dislodge, and remove the ash from the filter. The filter may have additional vibrating elements fixed directly to it, as shown in FIG. 1 and FIG. 3, or vibrating element **408** may be the sole source of the vibrations. One or more vibrating elements **408** may be used. The frequency, force, displacement, and other process control parameters may also be adjusted.

FIG. 5 shows a vibration-based filter cleaning system applied directly to a diesel particulate filter **508** installed on machine **500**. Machine **500** may be any machine containing a particulate filter **508**. The machine **500** may be stationary or contain one or more traction devices **502** for moving the machine. Particulate filter may be connected to an engine **504** via a conduit **506**. Exhaust from the filter **508** may be directed away from the machine **500** via conduit **510**. The particulate filter **508** and conduit **506** and **510** may be oriented horizontally, vertically, or at any angle with respect to the machine **500**.

One or more vibrating elements **512** may be attached to filter **508**. The vibrating elements **512** may further be connected to a power supply and controller, not shown. A connection **516** may be used to allow for an ash collection bin **518** to be connected to exhaust conduit **506**. A valve, plug or gating mechanism **514** may also be inserted into exhaust conduit **506**. The gating mechanism **514** has a first position where exhaust flows from the engine **504** to the filter **508**, and a second position where retentate flows upstream from the filter **508** to the ash collection bin **518**.

The vibrating element **512** may be used to loosen, dislodge, and remove ash from filter **508** while it is still installed on machine **500**. In one example, the ash thus dislodged and removed, is blown from the filter **508** and exhaust conduit **506** by application of reverse flow directed into exhaust conduit **510** with the engine off. A source of fluid flow, such as an air compressor or blower, may be in communication with conduit **510** to blow fluid upstream through the filter **508**. The ash may be carried by this flow into collection bin **518** via a conduit **506**. The collection bin **518** may be a container, bag, or second filter element. The collection bin **518** may be removed to dispose of the collected ash. Valve, plug or gating mechanism **514** may or may not be used to prevent the ash from blowing to the engine **504**. Application of reverse flow may or may not be required to remove the ash from the system. A vacuum system (not pictured) may be connected to connection **516** in place of the collection bin **518**, in another example. In another embodiment, filter cleaning may be accomplished using vibrations alone, such as when the filter **508** is mounted in a vertical orientation.

A particular example of a cleaning method will now be discussed. The vibrations applied to the filter can be characterized by an impulse on the filter. In this manner, the different "shaking" processes can be scaled and compared. Effective filter cleaning using vibrations can be obtained with relatively short shaking times, if the filter experiences a sudden loss in momentum (that is, it hits a surface). In one example, the speed just before the impact is about 5-10 cm/s without compromising the material integrity. Faster speeds result in substantial vibrations and sound. The specific impulse resulting for an almost instantaneous deceleration of the filter is then < 0.1 m/s (normalized by the mass of the filter).

The impulses can be generated in a harmonic manner, by using either mechanical or electrical means using pneumatic vibrators, vibrating motors, magnetostrictive elements, piezoelectric elements, ultrasonic or acoustic transducers, and the like. In the case where magnetostrictive elements are used, they may be driven in a non-harmonic manner, using a square-wave-like driving current.

In a particular example, the filter assembly, which includes the DPF, the can, matting and sensors, has a mass of about 70 kg. If the frequency of the vibrating element is f , then the time the force is applied is, approximately, $0.5/f$. The force F required to generate a specific impulse of 0.1 m/s with a mass of 70 kg operating at 500 Hz is about 7000 N. The corresponding acceleration provided by such a system is approximately 10 g.

The required power can also be calculated. The displacement of half a cycle is on the order of 50 microns. Thus the power required to drive the system is about 400 W.

Lower frequencies require lower power but larger displacements. Thus, at 60 Hz, the required force is 800 N, and the power is about 42 W. The acceleration from the shaking motion is however, only about 1 g. FIG. 6 shows the requirements for a specific impulse of 0.1 m/s, for a mass of 70 kg. The lower frequencies can be achieved using conventional motors (unbalanced motors). The higher frequencies can be achieved by using a magnetostrictive element, or other suitable devices.

Magnetostrictive materials are a class of ferromagnetic materials that change their length upon the application of a magnetic field. Several materials experience magnetostriction. At room temperature, TERFENOL-D is one example. In another example, three such actuators are fixed to support surface **402** in FIG. 4 or vibrating collar **308** in

FIG. 3. Each actuator is about 1 cm in diameter and 3 cm long, but wider or longer actuators can be used. They are driven by a high power audio amplifier.

The actuators have an elongation of about 100 microns, and require power of a few hundred Watts. The resonant frequency of the relatively short actuator is much higher than the operating frequency, and the field penetration is also fast. Operated at 500 Hz, the 3 actuators deliver about 6700 N, agreeing with the force required for shaking a mass of 70 kg at 500 Hz

Using square waveforms to drive the actuator is particularly helpful when the downward motion of the filter assembly is stopped, as it is at this time that it is likely that the ash will dislodge and fall to the receptacle at the bottom. The direction of acceleration can be easily changed by driving the actuators with different phases. It is possible even to drive the support surface **402** (FIG. 4) with different frequencies.

The vibration-based cleaning system and methods disclosed herein may be applied independently, or in conjunction with other cleaning methods such as forced air and thermal regenerators. Measurements of filter loading state and filter integrity (cracking, melting) may or may not be applied. Radio-frequency and microwave sensors, pressure sensors, flow measurements, ultrasonic measurements, x-ray measurements, ash mass measurements, and similar systems and parameters may also be used to determine the effectiveness of the cleaning process. Detectable powders, such as fluorescent powders, in one example, may be introduced into the reverse flow through the filter to detect filter failures. Other powders may also be used. Detection of the powders on the opposite side of the filter from which they were introduced may indicate a failure of the filter. In situ measurements or estimates of filter retentate levels

may also be used for real-time control of process parameters such as vibration orientation, frequency, and applied force during the cleaning process for example. The cleaning process may be stopped after a pre-determined amount of time has elapsed, or after a certain amount of retentate has been removed from the filter, or after residual retentate levels in the filter have been reduced to acceptable levels.

To aid the cleaning, charged particles can be added to the flows applied to the filter in order to neutralize charges present in the ash or soot or other retentate that helps it agglomerate and/or hold on to the walls of the filter. For best neutralization, both positive and negative charges can be applied. In the case of both charge polarities, the charges can be in the same space, or they can alternate in space or time. The charges can be generated by external corona discharges, among other production means.

It is intended that the examples and description provided in this disclosure be interpreted as illustrative and not in a limiting sense. The vibration-based cleaning system and methods disclosed are equally applicable to all types of diesel particulate filters, and all type of filters for that matter (pleated filters, paper filters, filter bags being some examples), regardless of material composition, configuration, or design. Further, the retentate may be soot, or ash, or any other material accumulated in filters. The retentate removed from the filter may be accumulated in plugs at the end of the filter channels, in layers on the filter surface, or in the filter pores.

What is claimed is:

1. A method of cleaning retentate from a filter, comprising:
providing one or more RF sensors for measuring the amount of retentate in the filter;
applying forced vibrations to a filter element, said forced vibrations being used to dislodge and remove retentate from the filter;
collecting said retentate in a retentate collection system; and
stopping the forced vibrations after the amount of retentate is reduced to a level as measured by the one or more RF sensors.
2. The method of claim 1, wherein said applying forced vibrations comprises applying vibrations of a first frequency and a first energy for a first time period to loosen said retentate.
3. The method of claim 2, wherein said applying forced vibration further comprises applying vibrations of a second frequency and a second energy for a second time period, after said first time period.
4. The method of claim 3, wherein said first frequency is less than said second frequency.
5. The method of claim 3, wherein said first frequency is less than 60 Hz and said second frequency is greater than 100 Hz.
6. The method of claim 3, wherein said first energy is greater than said second energy.
7. The method of claim 1, wherein the application of forced vibrations is stopped after a predetermined amount of time or after a specified amount of retentate has been removed from said filter element.
8. The method of claim 1, wherein measurements of filter retentate levels are used to vary the applied forced vibrations.
9. The method of claim 1, further comprising using a fluid to remove retentate dislodged by

said forced vibrations.

10. The method of claim 9, wherein said fluid is a liquid.
11. The method of claim 9, wherein said fluid is a gas.
12. The method of claim 1, wherein the direction of the forced vibrations is variable.
13. The method of claim 1, wherein forced vibrations perpendicular or parallel to channels of the filter element are used to break up and loosen retentate in the filter element.
14. The method of claim 13, wherein forced vibration parallel to the channels are used to remove the loosened retentate from the filter element.
15. The method of claim 1, wherein a location where the forced vibrations are applied varies while the filter element is being cleaned.
16. The method of claim 1, further comprising measuring ash deposits in the filter element, wherein a location where the forced vibrations are applied is based on measured ash deposits.

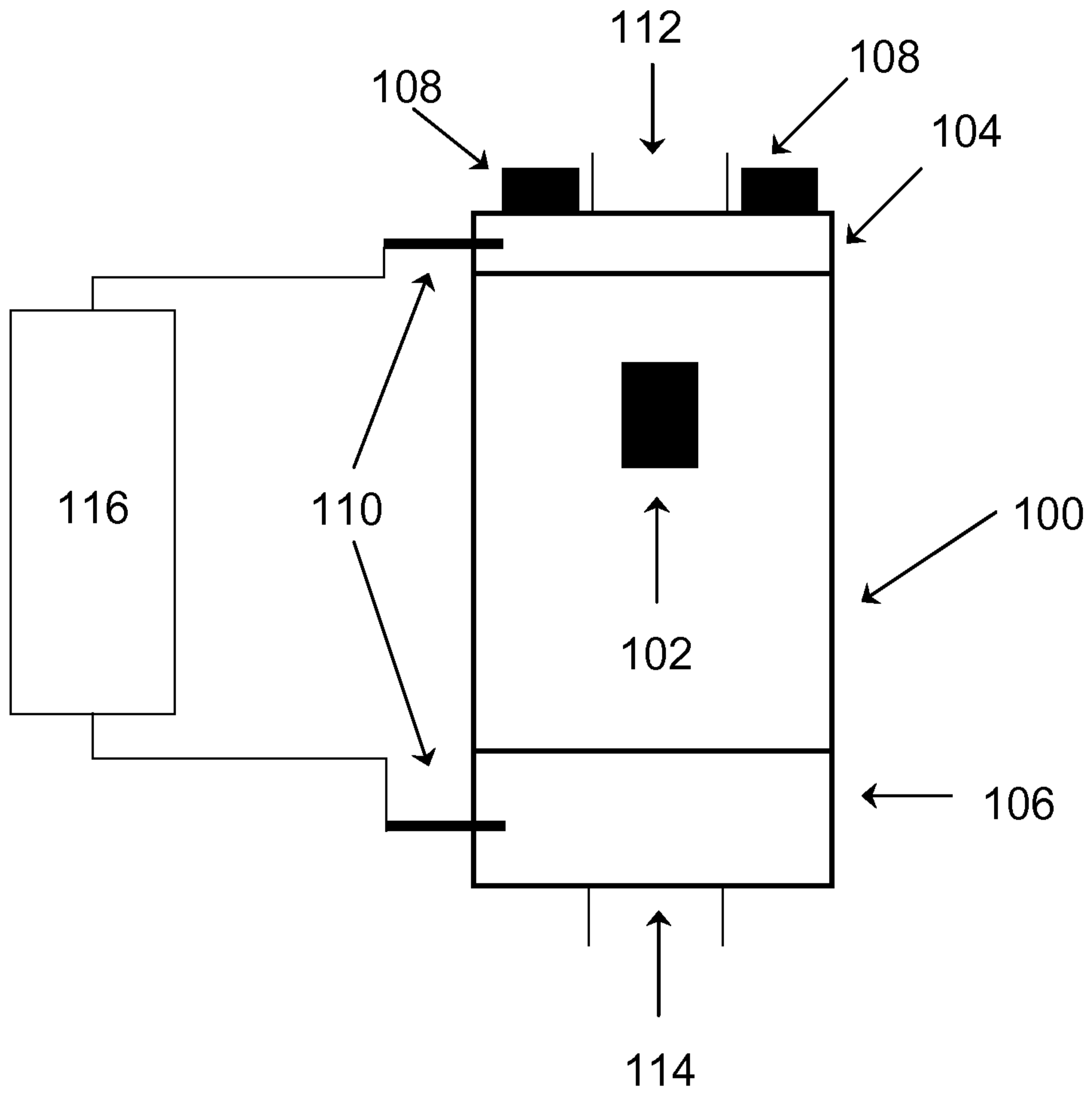

Figure 1.

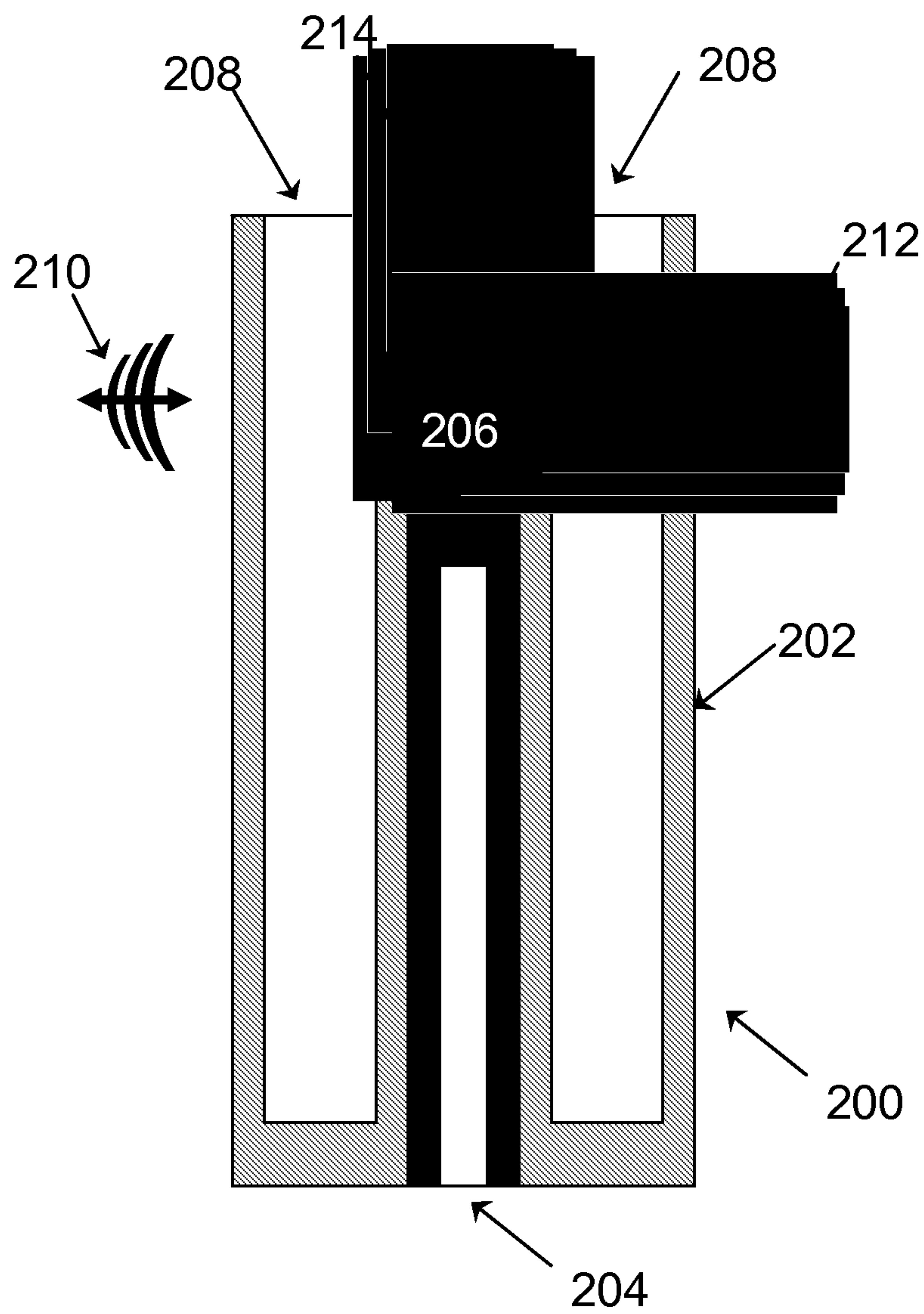

Figure 2.

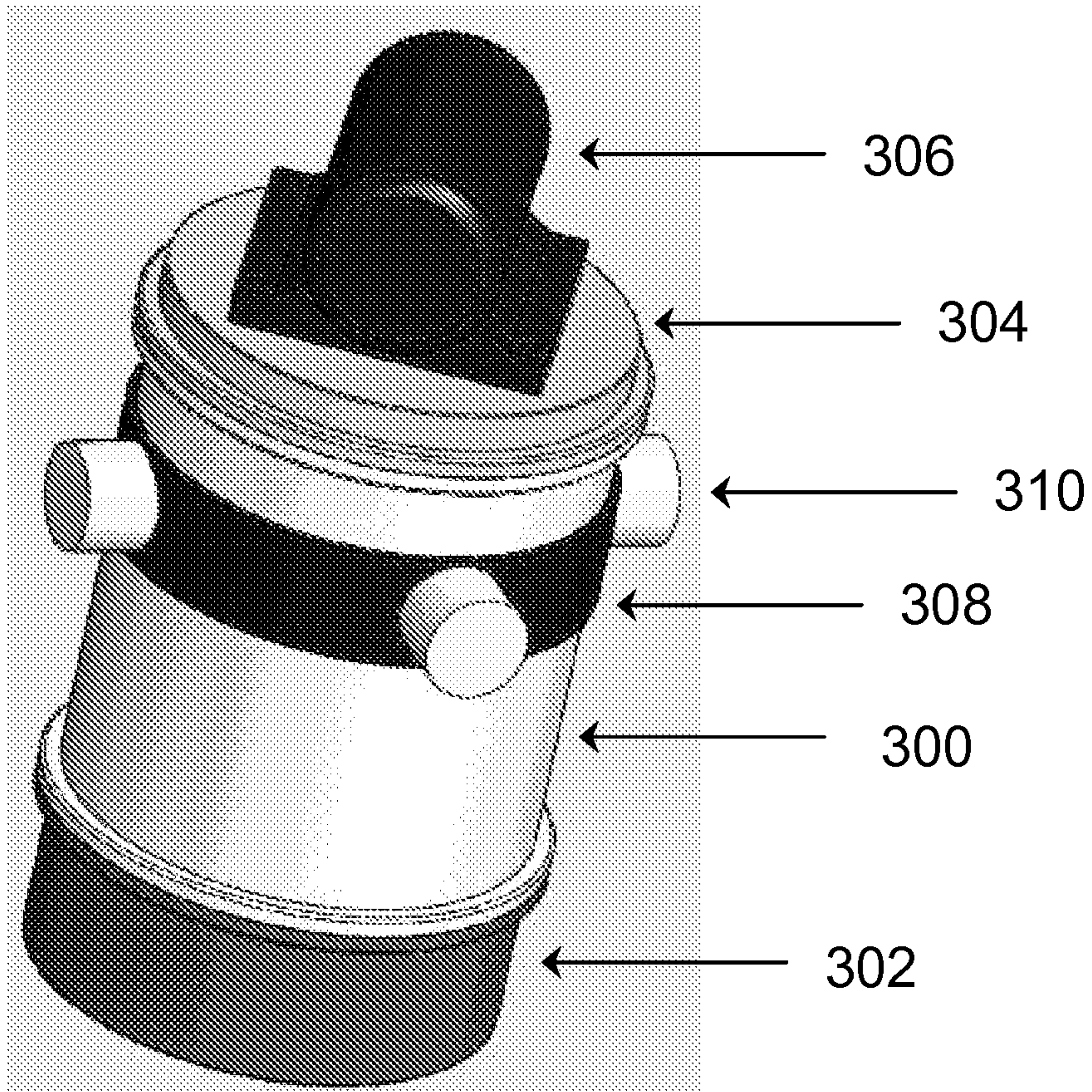

Figure 3.

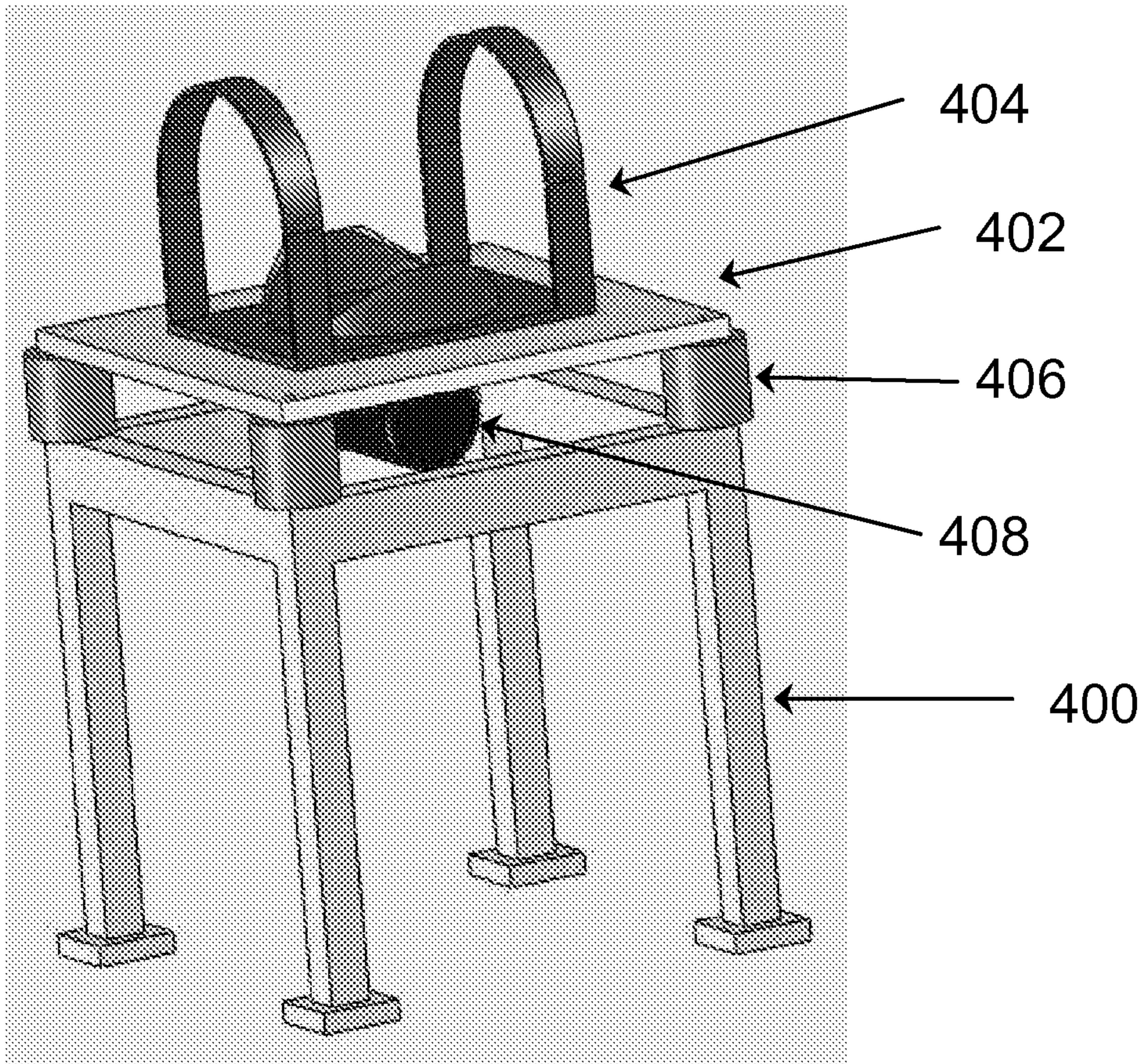

Figure 4.

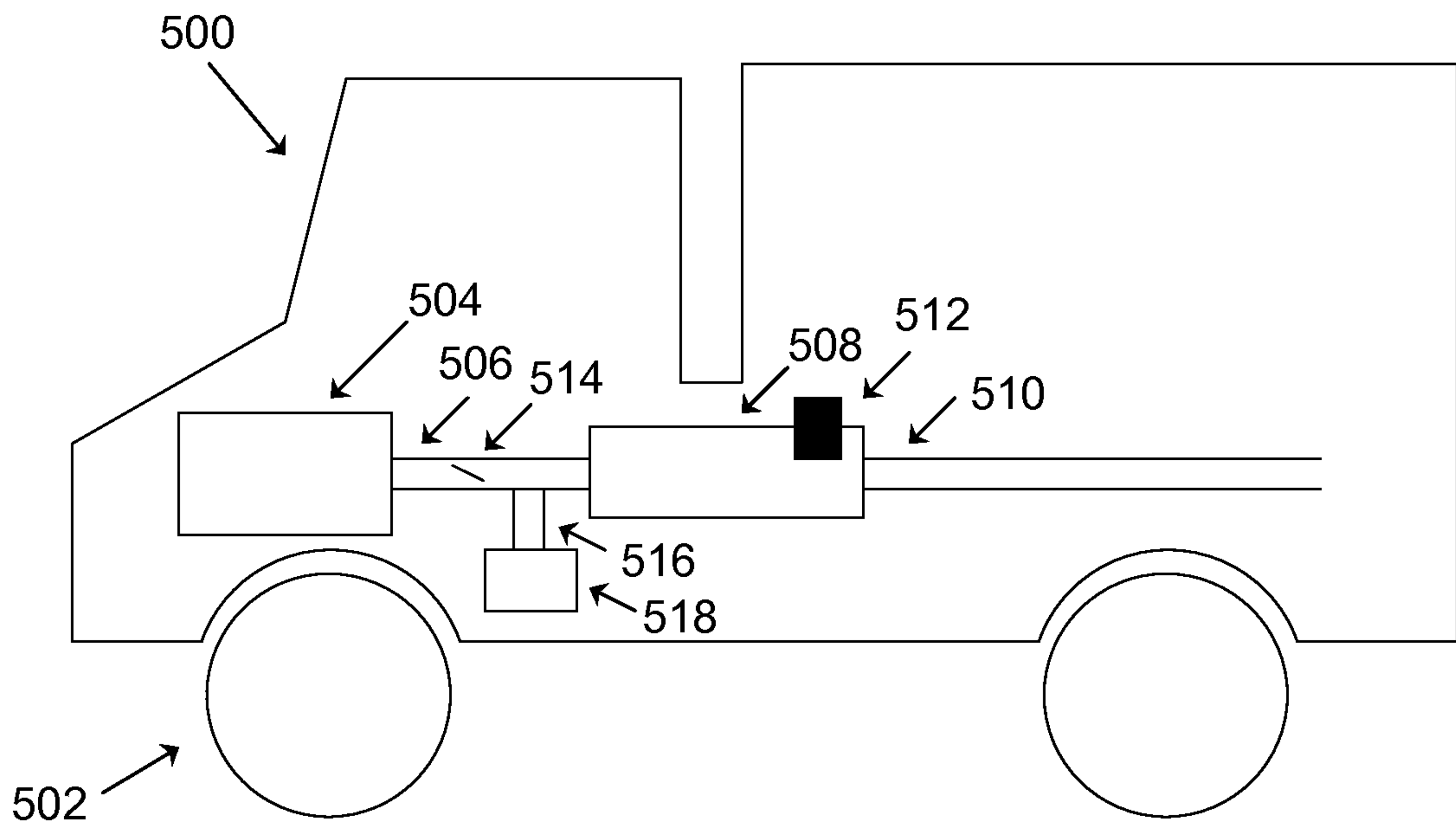

Figure 5.

Frequency	Hz	60	120	500	1000	2500
Half-cycle	s	8.3E-03	4.2E-03	1.0E-03	5.0E-04	2.0E-04
Impulse	m/s	0.1	0.1	0.1	0.1	0.1
acceleration	m/s ²	12	24	100	200	500
Mass	kg	70	70	70	70	70
Force	N	840	1680	7000	14000	35000
Displacement	m	4.2E-04	2.1E-04	5.0E-05	2.5E-05	1.0E-05
Work	J	0.35	0.35	0.35	0.35	0.35
Power	W	42	84	350	700	1750

Figure 6.

