

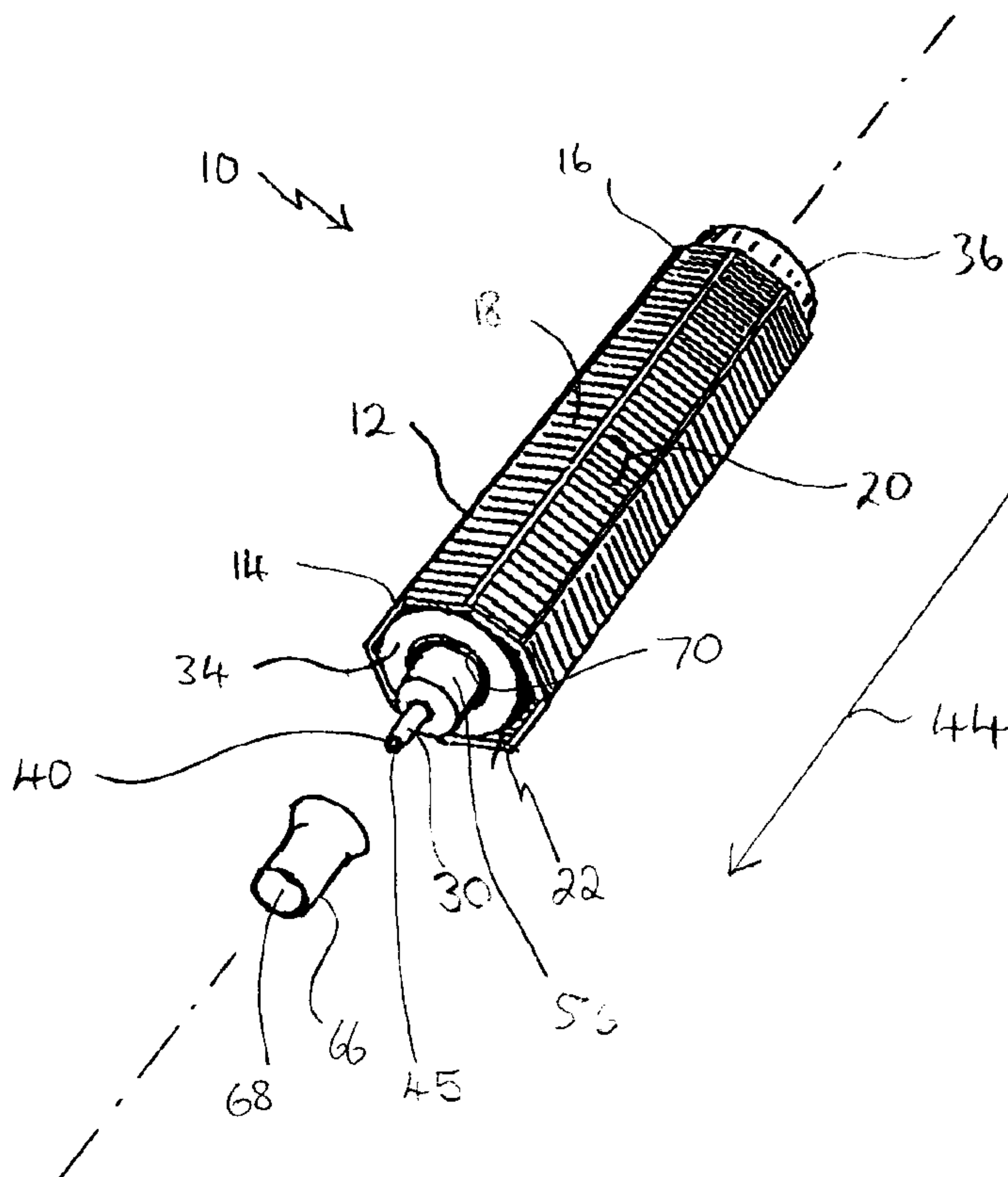

(22) Date de dépôt/Filing Date: 2000/02/11
(41) Mise à la disp. pub./Open to Public Insp.: 2001/08/11

(51) Cl.Int.⁷/Int.Cl.⁷ B01D 17/022, B01D 53/88, B01D 27/06, B01D 46/02
(71) Demandeur/Applicant: MUNRO, JAMES EDWARD, CA
(72) Inventeur/Inventor: MUNRO, JAMES EDWARD, CA
(74) Agent: THOMPSON, DOUGLAS B.

(54) Titre : UN FILTRE POUR UN APPAREIL DE FILTRATION DE LIQUIDES
(54) Title: A FILTER FOR A FLUIDS FILTRATION APPARATUS



(57) Abrégé/Abstract:

A filter for a fluid filtration apparatus which includes a containment envelope made from a filtration medium. The envelope has an inlet, an exterior surface, an interior. The envelope is wound in a spiral configuration with the inlet end centrally positioned thereby forming a spiral filtration core. The spiral filtration core has a central feed passage that communicates with the inlet of the envelope. When mixed fluids are directed into the central feed passage, a first fluid passes through the filtration medium forming the envelope and migrates along the exterior surface of the envelope to exit the spiral filtration core, and a second fluid unable to pass through the filtration medium migrates along the interior of the envelope.

ABSTRACT OF THE DISCLOSURE

A filter for a fluid filtration apparatus which includes a containment envelope made from a filtration medium. The envelope has an inlet, an exterior surface, an interior. The
5 envelope is wound in a spiral configuration with the inlet end centrally positioned thereby forming a spiral filtration core. The spiral filtration core has a central feed passage that communicates with the inlet of the envelope. When mixed fluids are directed into the central feed passage, a first fluid
10 passes through the filtration medium forming the envelope and migrates along the exterior surface of the envelope to exit the spiral filtration core, and a second fluid unable to pass through the filtration medium migrates along the interior of the envelope.

TITLE OF THE INVENTION:

A Filter For A Fluids Filtration Apparatus

NAME(S) OF INVENTOR(S):

5 James Edward Munro

FIELD OF THE INVENTION

The present invention relates to a filter for a fluids
filtration apparatus

10

BACKGROUND OF THE INVENTION

The effectiveness of a filter depends to a great extent
upon the amount of surface area that the filter contains. As
a general rule the greater the surface area, the more effective
15 the filter.

The effectiveness of the filter also depends upon the
amount of surface area that is use. Fluids flowing through a
filter follow a path of least resistance. This "channelling"
20 of fluids along the path of least resistance often results in
only a portion of the surface area of the filter being used,
which greatly diminishes surface area exposure of the fluids
to the filtration medium.

25 SUMMARY OF THE INVENTION

What is required is a filter for a fluids filtration
apparatus that will provide an increased surface area for
filtration and which will be less prone to channelling.

30 According to the present invention there is provided a
filter for a fluid filtration apparatus. The filter includes
a containment envelope made from a filtration medium. The
containment envelope has an inlet, an exterior surface, and an
interior. The containment envelope is wound in a spiral
35 configuration with the inlet end centrally positioned thereby

forming a spiral filtration core. The spiral filtration core has a central feed passage that communicates with the inlet of the envelope. When mixed fluids are directed into the central feed passage, a first fluid passes through the filtration medium forming the envelope and migrates along the exterior surface of the envelope to exit the spiral filtration core, and a second fluid unable to pass through the filtration medium migrates along the interior of the envelope.

10 The above described spiral filtration core, provides a considerable surface area of filtration medium to which fluids are exposed, along with a flow path that is unlikely to be subject to channelling. The spiral configuration permits a comparatively large filtration surface area to be packed into
15 a relatively small space. The life and solids loading capability of the filter is increased. This configuration can be used in a wide variety of filtration applications by selecting an appropriate filtration medium. In tests it has proven to be effective in separating fluids having differing
20 properties. For such application a filtration medium is used that will enable a first fluid to pass, but will prevent or resist the passage of a second fluid.

Although beneficial results may be obtained through the
25 use of the filter, as described above, some filtration processes are more effective if undertaken under pressure. Even more beneficial results may, therefore, be obtained when the spiral filtration core is contained to limit its radial expansion, so that it does not expand to the point of bursting.
30 When operating under pressure, a pressure differential is created between the pressure inside of the envelope and the pressure outside of the envelope. This pressure differential helps accelerate the process of separating the fluids.

35 Although beneficial results may be obtained through the use of the filter, as described above, the process of separating the fluids may also be accelerated through the use

of a catalyst. Even more beneficial results may, therefore, be obtained when a fluid permeable spacer material is wound in a spiral configuration with the containment envelope. The spacer material can be either positioned inside of the
5 containment envelope or outside of the containment envelope. A mesh is the preferred type of suitable spacer. The material out of which the mesh is made is selected to trigger a reaction, such as oxidization.

10 BRIEF DESCRIPTION OF THE DRAWINGS

These and other features of the invention will become more apparent from the following description in which reference is made to the appended drawings, wherein:

FIGURE 1 is a perspective view of a preferred embodiment
15 of filter constructed in accordance with the teachings of the present invention.

FIGURE 2 is an exploded perspective view of the filter illustrated in **FIGURE 1**.

FIGURE 3 is a side elevation view, in section, of the
20 filter illustrated in **FIGURE 1**.

FIGURE 4 is a cutaway perspective view of a fluids filtration apparatus equipped with the filter illustrated in **FIGURE 1**.

25 DETAILED DESCRIPTION OF THE PREFERRED EMBODIMENT

The preferred embodiment, a filter for a fluids filtration apparatus generally identified by reference numeral 10, will now be described with reference to **FIGURES 1** through **4**.

30 Referring to **FIGURE 2**, filter 10 has a housing 12 having a first end 14, a second end 16, and peripheral sidewalls 18 defining an interior cavity 20. A spiral filtration core 22 is disposed within interior cavity 20 of housing 12. Spiral filtration core 22 has a first end 54 and a second end 50.
35 Spiral filtration core 22 consists of a containment envelope 24 made from filtration medium and a fluid permeable spacer material 26. Containment envelope 24 has an inlet 25, an

exterior surface 29, an interior 31 and a closed end 27 remote from inlet 25. In order to form spiral filtration core 22 fluid permeable spacer material 26 and containment envelope 24 are wound in a spiral configuration with inlet end 25 of envelope centrally positioned in spiral filtration core 22. Fluid permeable spacer material 26 helps in the formation of a plurality of flow spaces 33 in spiral filtration core 22 along exterior surface 29 of envelope 24, and can also serve a dual function serving as a catalyst substrate, as will hereinafter be further described.

Spiral filtration core 22 has a central feed passage 28 that communicates with inlet 25 of envelope 24. Fluids being filtered are directed under pressure into central feed passage 28 via a feed tube 30. Feed tube 30 has a first end 40, a second end 42, and a peripheral sidewall 43. An inlet 45 is positioned at first end 40. Second end 42 is closed. A plurality of outlets 32 are positioned along a length of peripheral sidewall 43 allow a fluid entering at first end 40 of feed tube 30 to pass radially outward from feed tube 30 into inlet 35 of envelope 24. Although outlets 32 can have any one of several shapes, it is preferred that outlets 32 be slotted. Optionally, a catalyst substrate 37 may be positioned

The use and operation of filter 10 will now be described with reference to **FIGURES 1** through **4**. Referring to **FIGURE 3**, mixed fluids, indicated by arrow 51 are directed through feed tube 30 into central feed passage 28 where the mixed fluids pass through slotted outlet 32 into inlet 25 of envelope 24. A first fluid passes through the filtration medium out of which envelope 24 is made, as indicated by arrows 53, and migrates through fluid permeable spacer material 26 along exterior surface 29 of envelope 24 to exit spiral filtration core 22. A second fluid, unable to pass through the filtration medium out of which envelope 24 is made, migrates along interior 31 of envelope 24, as indicated by arrows 55 until it reaches closed end 27. When filter 10 is being used for a batch

processing application, envelope 24 is removed and emptied when it becomes filled with the second fluid. Envelope 24 is, then, cleaned and reused. Alternatively, envelope 24 can be backwashed without being removed. In continuous flow applications, the second fluid overflows back through inlet 25.

It will be understood that in operation, spiral filtration core 22 tends to expand as fluids enter inlet 25 of envelope 24. Referring to **FIGURE 2**, constricting bands 34 and 36 are, therefore, positioned around spiral filtration core 22 to limit such expansion. In pressure applications, it is preferred that spiral filtration core 22 be contained within housing 12, so that expansion is limited by peripheral sidewalls 18 of housing 12. As long as the expansion is confined so that filtration core 22 does not burst due to pressure, creating a pressure differential between interior 31 of envelope 24 and exterior surface 29 of envelope 24 serves to enhance the filtration process.

20

It has been found that advantages accrue from the use of a sheet of mesh. When the mesh is placed along exterior surface 29 of envelope 24, prior to winding filtration core 22, the mesh serves as fluid permeable spacer material 26. However, the mesh can be made from either reactive or non-reactive materials and can, therefore, serve as a catalyst substrate. Although some benefits can be obtained when fluid permeable spacer material 26 is also, a catalyst substrate, it is more beneficial to have a catalyst substrate within envelope 24. Where a catalyst substrate 37 within envelope 24 is desired, mesh is inserted into interior 31 of envelope 24 prior to winding filtration core 22. An example of a reactive material is a $MN O^2$ catalyst coating on a mesh substrate which promotes an oxidization reaction. Examples of non-reactive materials are teflon or stainless steel mesh which is unaffected by a large variety of fluids to be treated. Mesh is flexible enough to allow spiral filtration core 22 to be formed, and yet is rigid

enough to enable spiral filtration core 22 to retain its spiral shape and is strong enough to provide firm support for filtration medium 24 when spiral filtration core 22 is operated under pressure. Mesh can also be given a reactive coating or
5 a static charge to promote secondary processing of the first fluid.

Referring to **FIGURES 1 and 2**, spiral filtration core 22 fits within housing 12. Feed tube 30 extends from central feed
10 passage 28 at first end 54 of spiral filtration core 22. An annular travelling seal 56 is positioned at first end 54 of spiral filtration core 22. Travelling seal 56 has a central passage 64. Feed tube 30 is positioned in central passage 64, so that travelling seal 56 encircles in close fitting relation
15 first end 40 of feed tube 30. Travelling seal 56 provides a seal between feed tube 30 and central feed passage 28. A further O-ring seal 70 is used in conjunction with travelling seal 56. Optionally, a spiral spring 58 may be used in conjunction with travelling seal 56 to assist with alignment
20 when filter 10 is installed in housing 12.

In the oil industry, waste gas is diverted to a flare to be burned. Freezing problems are encountered in pipes leading to the flare in winter weather due to condensation. Filter 10,
25 as described above, can be used to remove water from such waste gas. For such applications envelope 24 is made using a hydrophobic filter medium. Referring to **FIGURE 4**, at least one but, preferably, several filters 10 are situated within a pressure vessel 101. Pressure vessel 101 has a mixed fluids
30 inlet 126 for fluids to be filtered (in this case - "wet" gas containing gas with entrained water vapour), a first outlet 138 for recovery of the first fluid (in this case - "dry" gas) and a second outlet 152 for recovery of the second fluid (in this case - water). Pressure vessel 101 has a body 100 with a first
35 end 102, a second end 104 and peripheral sidewalls 106. Filters 10 are situated within pressure vessel 101, and second end 104 of body 100 is closed with a lid 108 and sealed by an

O-ring seal 110. A tube 112 extends from first end 102 through lid 108 at second end 104 of body 100. Tube 112 has a first end 114 and a second end 116. First end 114 is secured to first end 102 of body 100. A threaded connector 118 matingly
5 engages second end 116 of tube 112, thereby providing a clamping force against lid 108 to urge O-ring seal 110 into sealing engagement with second end 104 of body 100. A cover 122 is secured at second end 104 of body 100 by securing means, illustrated as a clamp 124. A pressure gauge 122 extends
10 through cover 122. A bypass safety valve 132 leading to a bypass pipe 144 is connected to inlet pipe 128. A manual shut off valve 134 is provided to facilitate maintenance and replacement of bypass safety valve 132. A pressure gauge 136 is used to measure a pressure of fluid in inlet pipe 128.
15 "Wet" gas is fed through an inlet pipe 128 in a direction indicated by arrow 130 into mixed fluids inlet 126. The fluid moves under pressure through mixed fluids inlet 126 into first end 40 of feed tubes 30 of each filter 10. Referring to **FIGURE 3**, the hydrophobic filtration medium of envelope 24 allows gas
20 to pass, but retains water within envelope 24. "Wet" gas migrates radially outward through outlets 32 of feed tube 30 into inlet 25 of envelope 24. The "dry" gas passes through the filtration medium out of which envelope 24 is made, as indicated by arrows 53, and migrates through fluid permeable
25 spacer material 26 along exterior surface 29 of envelope 24 to exit spiral filtration core 22. Referring to **FIGURE 4**, this "dry" gas then passes through first outlet 138 into a first outlet pipe 140, as indicated by arrow 142. As previously described, a bypass pipe 144 connects inlet pipe 128 to safety
30 valve 132. When the flow through pressure vessel 101 is restricted, for example by a clogged filter, pressure builds up. When this pressure build up rises above a selected value in inlet pipe 128, safety valve 132 is activated to open and relieve the pressure. When safety valve 132 opens, the gas
35 stream is able to bypass pressure vessel 101 through bypass pipe 144. Referring to **FIGURE 3**, hydrophobic filtration medium 24 is impermeable by water. Water cannot pass through envelope

24 tends to condense on the filtration medium out of which envelope 24 is made. As condensate accumulates, water migrates along interior 31 of envelope 24, as indicated by arrows 55. The condensation can be accelerated by the selection of an appropriate catalyst substrate 37. Even if a non-reactive mesh is used as a catalyst substrate, it will provide a surface onto which water vapour may condense. In a batch process, water would be allowed to accumulate in envelope 24, and envelope 24 would periodically be removed and emptied. It is preferred, however, that the process be continuous. In order to make the process continuous, water is allowed to overflow back out of inlet 25. Water which overflows accumulates in a second fluid collection area 150 at first end 102 of body 100, from where it is removed through a second outlet 152 into a second outlet pipe 154 as indicated by arrow 156. It is recommended that second outlet 152 be float controlled so that second outlet 152 opens to allow water to drain into second outlet pipe 154, whenever the float rises above a preset level.

It will be apparent to one skilled in the art that other fluids can be filtered by merely changing the filtration medium out of which envelope 24 is fabricated. For example, a hydrophobic fluid can be separated from a mixture with water, when the filtration medium out of which envelope 24 is fabricated is a hydrophillic material. Referring to **FIGURE 4**, a mixed fluid of water and hydrophobic fluid is fed into inlet 25 of envelope 24. Water passes through the hydrophillic filtration medium out of which envelope 24 is made and then migrates through fluid permeable spacer material 26 along exterior surface 29 of envelope 24 to exit spiral filtration core 22. The hydrophobic fluid is unable to pass through the filtration medium out of which envelope 24 is made. The hydrophobic fluids must, therefore, migrates along interior 31 of envelope 24, as indicated by arrows 55. As previously described, an appropriate catalyst substrate 37 may be selected to accelerate the separation process. As previously described, the unit can be configured for either batch processing or

continuous processing. Depending upon the nature and volume of fluids being separated, batch processing may be more appropriate. Once envelope 24 is removed, it can be cleaned and reused.

5

It will be apparent to one skilled in the art that the described filter can be used in separating solids from liquids, separating liquids for liquids, separating gases from liquids, separating gases from gases, and for separating solid particles
10 from gases. It will also be apparent to one skilled in the art that closed end 27 of envelope 24 could be left open in whole or in part, if pressure was not required for the separation and if an alternative flow path was arranged from end 27. It will further be apparent to one skilled in the art that the
15 described filter could work to a limited degree with a reversal of flow from the exterior surface into the interior of the envelope. The limitation of such a reversal or inverse flow is that instead of pressure tending expand the envelope, pressure would tend to collapse the envelope. The collapse of
20 the envelope would prevent is from functioning as intended. It will finally be apparent to one skilled in the art that modifications may be made to the illustrated embodiment without departing from the spirit and scope of the invention as hereinafter defined in the Claims.

25

THE EMBODIMENTS OF THE INVENTION IN WHICH AN EXCLUSIVE PROPERTY OR PRIVILEGE IS CLAIMED ARE DEFINED AS FOLLOWS:

- 5 1. A filter for a fluid filtration apparatus, comprising:
a containment envelope made from a filtration medium, the envelope having an inlet, an exterior surface, an interior and being wound in a spiral configuration with the inlet end centrally positioned thereby forming a spiral filtration core;
10 the spiral filtration core having a central feed passage that communicates with the inlet of the envelope, such that when mixed fluids are directed into the central feed passage, a first fluid passes through the filtration medium forming the envelope and migrates along the exterior surface of the
15 envelope to exit the spiral filtration core, and a second fluid unable to pass through the filtration medium migrates along the interior of the envelope.
2. The filter as defined in Claim 1, wherein the second fluid
20 becomes trapped within the envelope, eventually filling the envelope to capacity.
3. The filter as defined in Claim 1, wherein the second fluid fills the envelope and then overflows back out through the
25 inlet.
4. The filter as defined in Claim 1, wherein a fluid permeable spacer material is wound in a spiral configuration with the containment envelope thereby forming a flow space in the spiral
30 filtration core for the migration of the first fluid along the exterior surface of the envelope.
5. The filter as defined in Claim 1, wherein a catalyst substrate is positioned within the containment envelope to
35 promote the separation of the first fluid and the second fluid.
6. The filter as defined in Claim 1, wherein the filtration

medium is hydrophobic.

7. The filter as defined in Claim 1, wherein a housing is provided having an interior cavity, the spiral filtration core being positioned within the interior cavity, the housing limiting radial expansion of the spiral filtration core.

8. The filter as defined in Claim 1, wherein a feed tube is positioned in the central feed passage.

9. The filter as defined in Claim 8, wherein the feed tube has a first end, a second end, and a peripheral sidewall, with an inlet at one of the first end and the second end and at least one outlet through the peripheral sidewall.

10. The filter as defined in Claim 9, wherein there are a plurality of slotted outlets through the peripheral sidewall.

11. The filter as defined in Claim 8, wherein an annular fluid impermeable stop encircles one end of the feed tube and provides a seal between the feed tube and the central feed passage.

12. The filter as defined in Claim 1, wherein constricting bands are positioned around the spiral filtration core to limit radial expansion of the spiral filtration core.

13. The filter as defined in Claim 4, wherein the fluid permeable spacer material is a mesh.

14. The filter as defined in Claim 5, wherein the catalyst substrate is a material selected to promote an oxidization reaction with the first fluid.

15. The filter as defined in Claim 13, wherein the mesh is of stainless steel.

16. The filter as defined in Claim 1, wherein the filtration medium is a teflon coated polyurethane membrane.

17. The filter as defined in Claim 5, wherein the catalyst
5 substrate is statically charged.

18. A filter for a fluid filtration apparatus, comprising:
a containment envelope made from a filtration medium, the
envelope having an inlet, an exterior surface, and an interior;
5 a layer of fluid permeable mesh material;
the containment envelope and the layer of fluid permeable
mesh material being wound in a spiral configuration with the
inlet of the envelope centrally positioned thereby forming a
spiral filtration core with a flow space formed in the spiral
10 filtration core along the exterior surface of the envelope by
the layer of fluid permeable mesh material;
the spiral filtration core having a central feed passage
that communicates with the inlet of the envelope, such that
when mixed fluids are directed into the central feed passage,
15 a first fluid passes through the filtration medium and migrates
through the fluid permeable mesh material along the exterior
surface of the envelope to exit the spiral filtration core, and
a second fluid unable to pass through the filtration medium
migrates along the interior of the envelope; and
20 means for limiting radial expansion of the spiral
filtration core.

19. A filter for a fluid filtration apparatus, comprising:
a containment envelope made from a filtration medium, the
envelope having an inlet, an exterior surface, and an interior;

5

the containment envelope and the layer of fluid permeable
mesh material being wound in a spiral configuration with the
inlet of the envelope centrally positioned thereby forming a
spiral filtration core with a flow space formed in the spiral
10 filtration core along the exterior surface of the envelope by
the layer of fluid permeable mesh material;

the spiral filtration core having a central feed passage
that communicates with the inlet of the envelope, such that
when mixed fluids are directed into the central feed passage,
15 a first fluid passes through the filtration medium and migrates
through the fluid permeable mesh material along the exterior
surface of the envelope to exit the spiral filtration core, and
a second fluid unable to pass through the filtration medium
migrates along the interior of the envelope;

20 a catalyst substrate being positioned within the
containment envelope to promote the separation of the first
fluid and the second fluid; and

means for limiting radial expansion of the spiral
filtration core.

25

20. A fluid filtration apparatus, comprising:

a pressure vessel having an inlet for mixed fluids, a first outlet for recovery of a first fluid;

5 several filter housings positioned within the pressure vessel, each of the housings containing a filter, the filter comprising:

a containment envelope made from a filtration medium, the envelope having an inlet, an exterior surface, and an interior;

10 the containment envelope being wound in a spiral configuration with the inlet of the envelope centrally positioned thereby forming a spiral filtration core with a flow space formed in the spiral filtration core along the exterior surface of the envelope;

15 the spiral filtration core having a central feed passage that communicates with the inlet of the envelope, a feed tube being positioned in the central feed passage to direct mixed fluids flowing through the mixed fluids inlet of the pressure vessel into the inlet of the envelope, such that mixed fluids are directed into the inlet of the envelope, a first fluid passes through the filtration medium and migrates along the exterior surface of the envelope to exit the spiral filtration core and pass to the first fluids outlet of the pressure vessel, and a second fluid unable to pass through the filtration medium migrates along the interior and fills the envelope, the spiral filtration core expanding radially during operation due to a pressure differential between the interior of the envelope and the exterior surface of the envelope such

20 radial expansion being confined by the filter housing.

21. The fluid filtration apparatus as defined in Claim 20, wherein the pressure vessel has a second outlet for recovery of a second fluid, the second fluid overflowing the spiral filtration core once the envelope is filled and migrating back through the inlet of the envelope to the second fluids outlet of the pressure vessel.

35

22. The filter as defined in Claim 20, wherein a fluid permeable spacer material is wound in a spiral configuration with the containment envelope thereby forming a flow space in the spiral filtration core for the migration of the first fluid
5 along the exterior surface of the envelope.

23. The filter as defined in Claim 20, wherein a catalyst substrate is positioned within the containment envelope to promote the separation of the first fluid and the second fluid.
10

24. The filter as defined in Claim 23, wherein the catalyst substrate is statically charged.

25. The fluid filtration apparatus as defined in Claim 20,
15 wherein the pressure vessel has means for backwashing the filter.

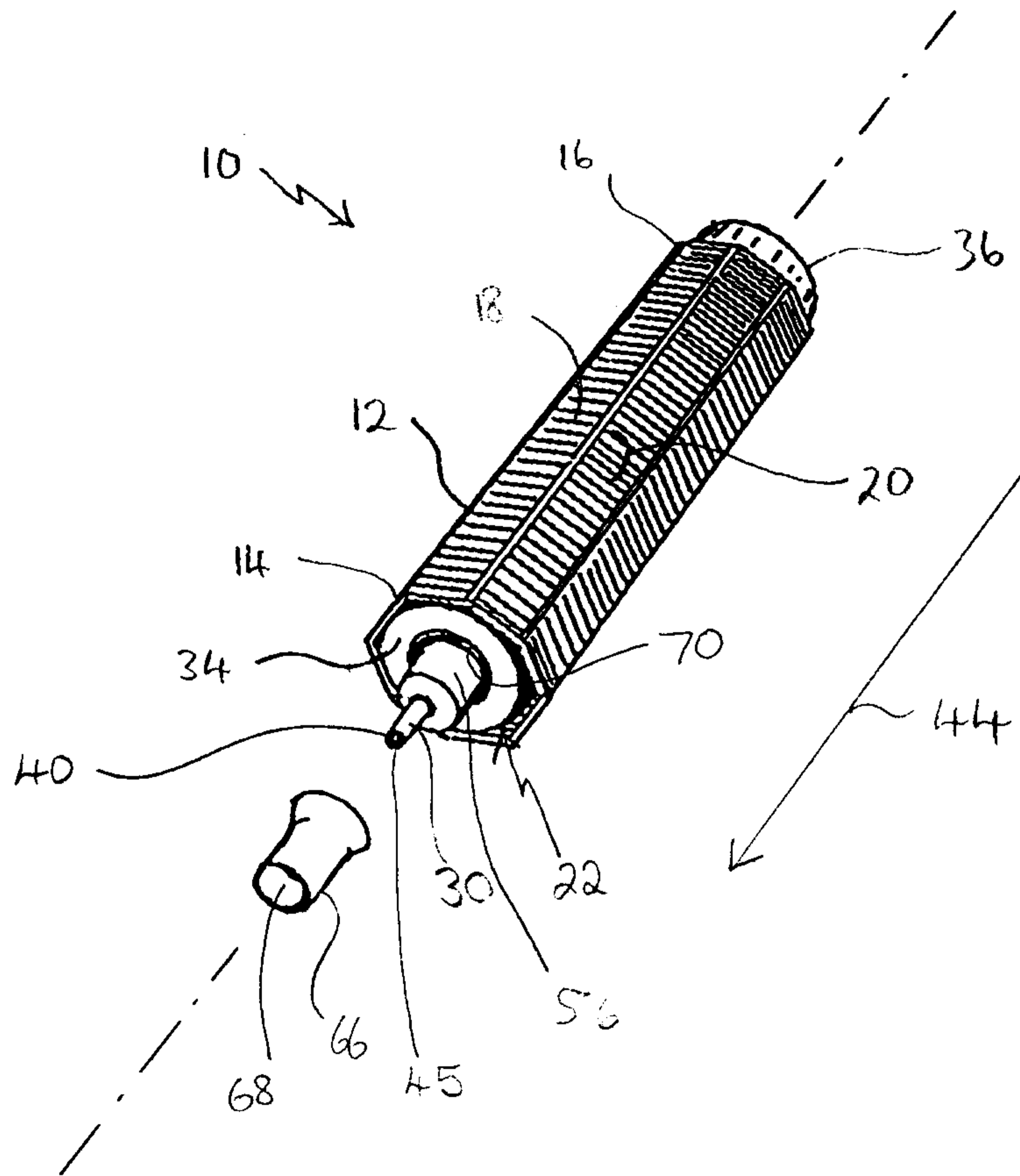

FIGURE 1

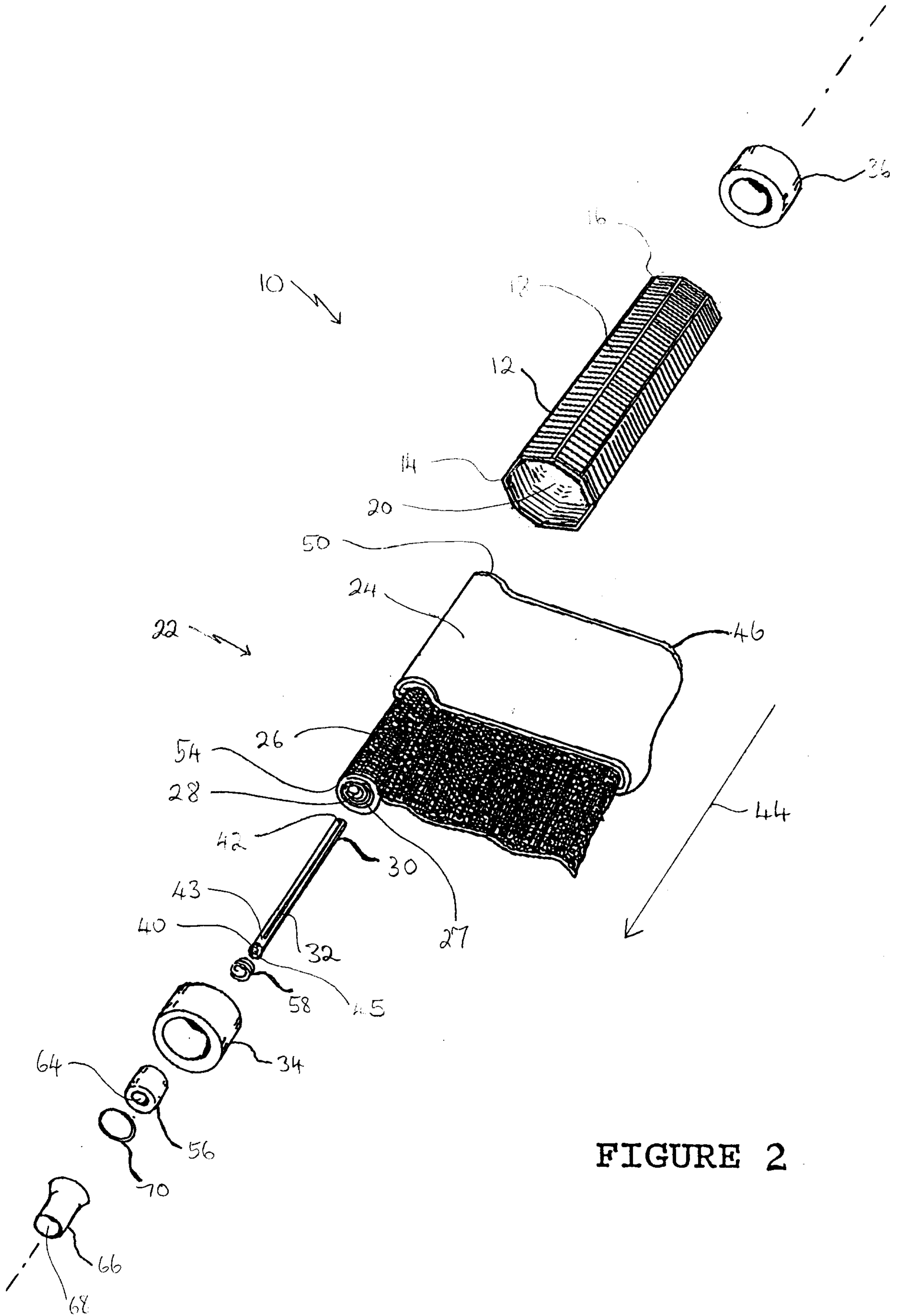

FIGURE 2

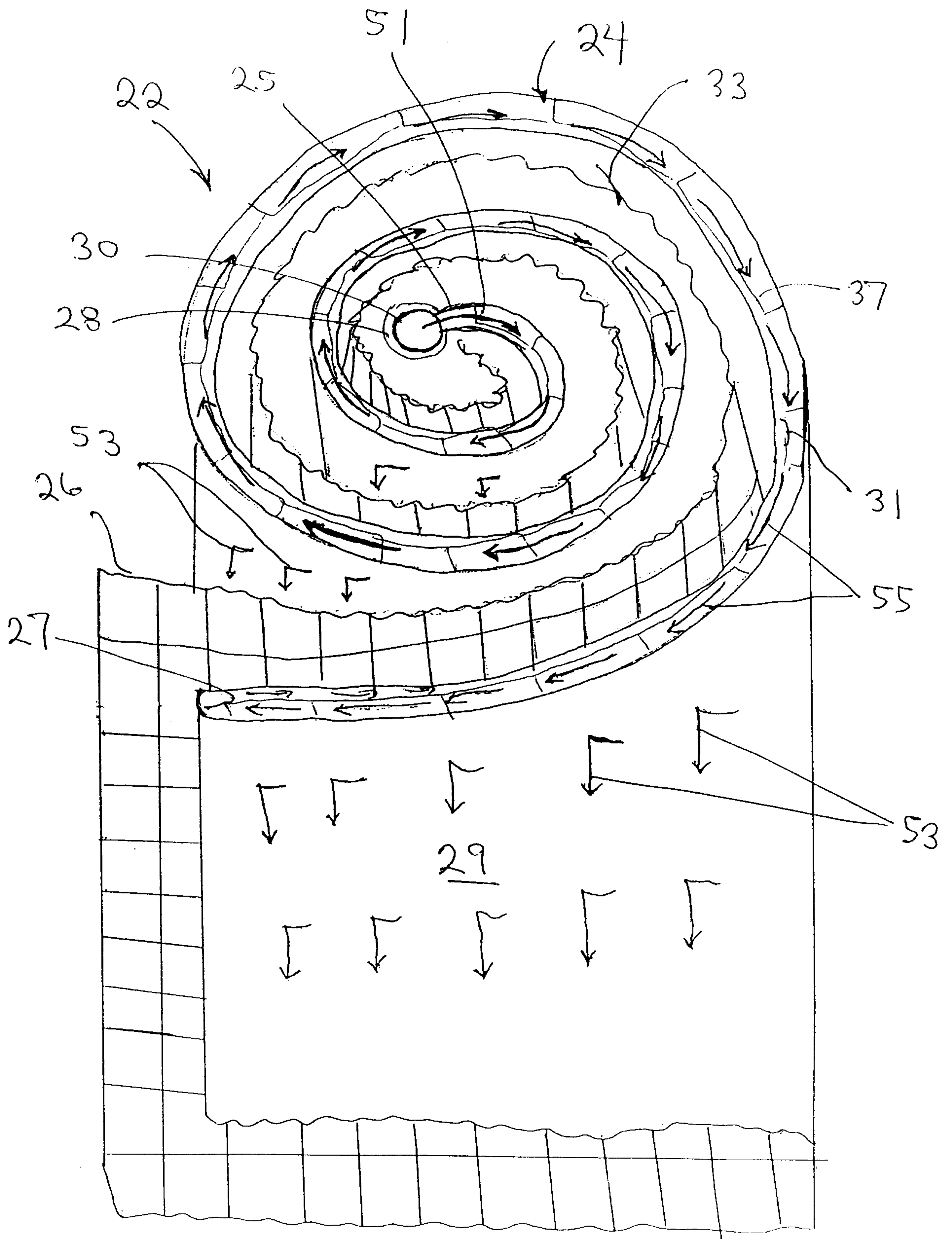

FIGURE 3

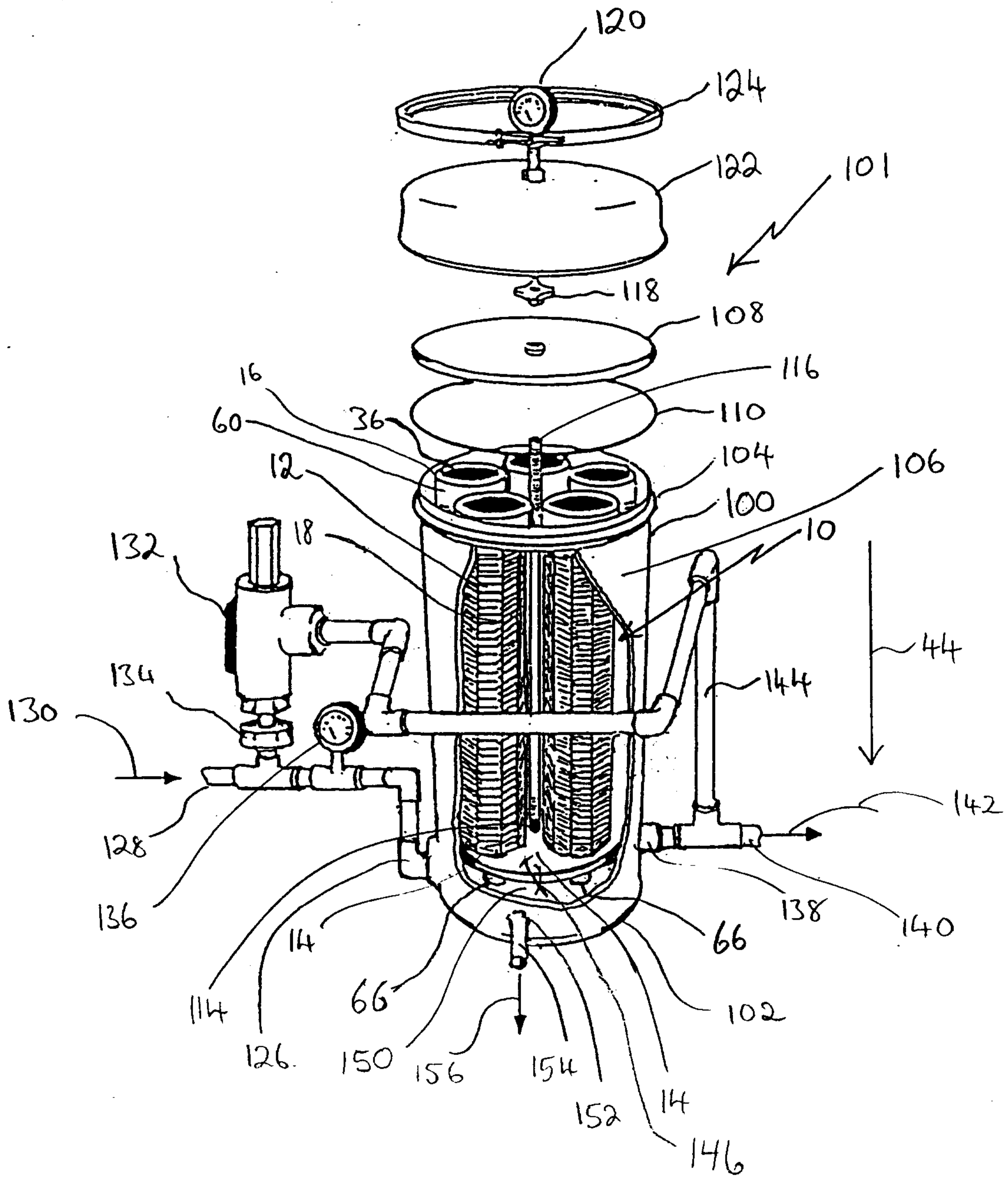

FIGURE 4

