

(No Model.)

5 Sheets—Sheet 1.

W. N. WHITELEY & W. BAYLEY.
KNOTTER FOR GRAIN BINDERS.

No. 525,672.

Patented Sept. 4, 1894.

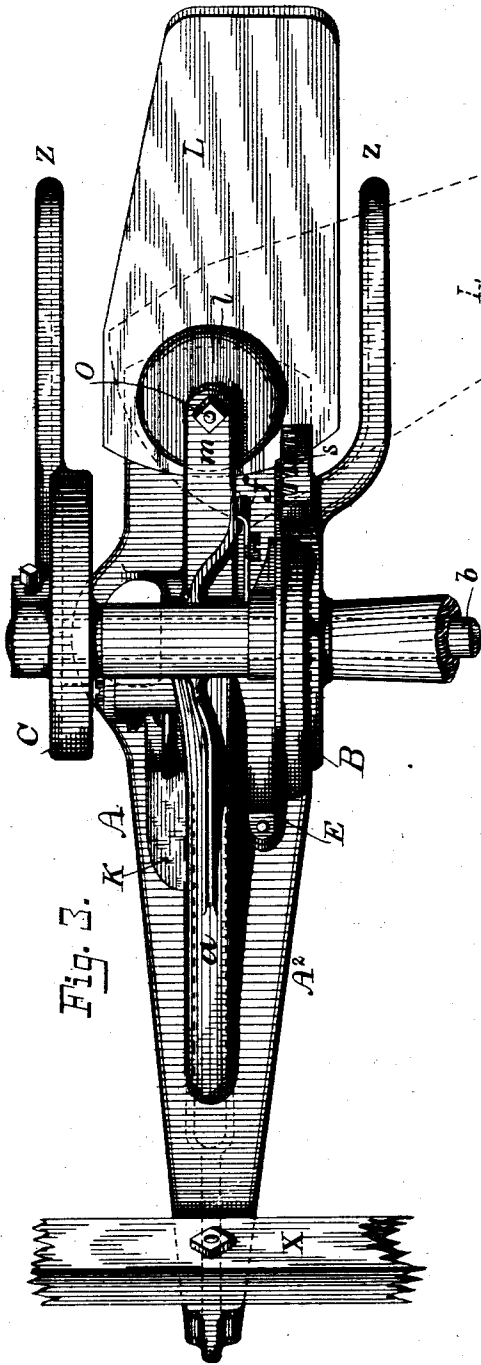

Fig. 3.

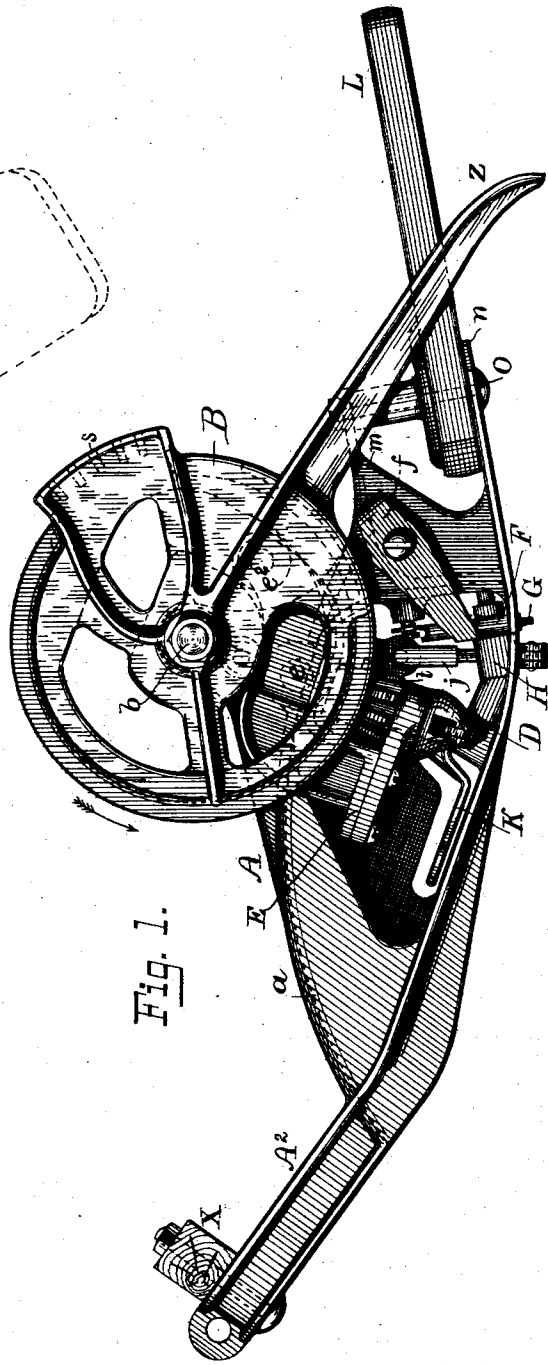

Fig. 1.

Witnesses:

Oscar & Perrigo
Fred State

Inventors:

William N. Whiteley
William Bayley

(No Model.)

5 Sheets—Sheet 2.

W. N. WHITELEY & W. BAYLEY.
KNOTTER FOR GRAIN BINDERS.

No. 525,672.

Patented Sept. 4, 1894.

Fig. 4.

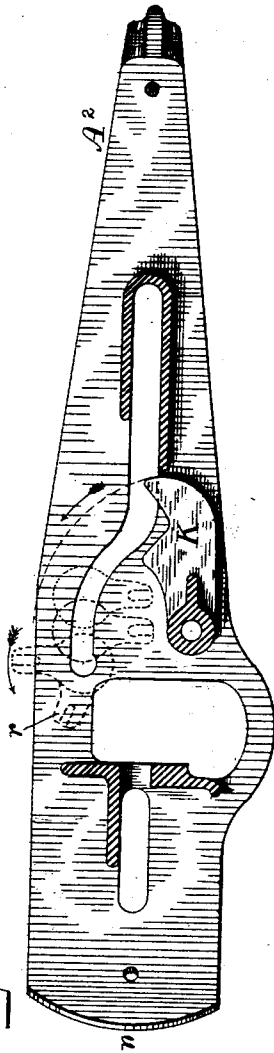
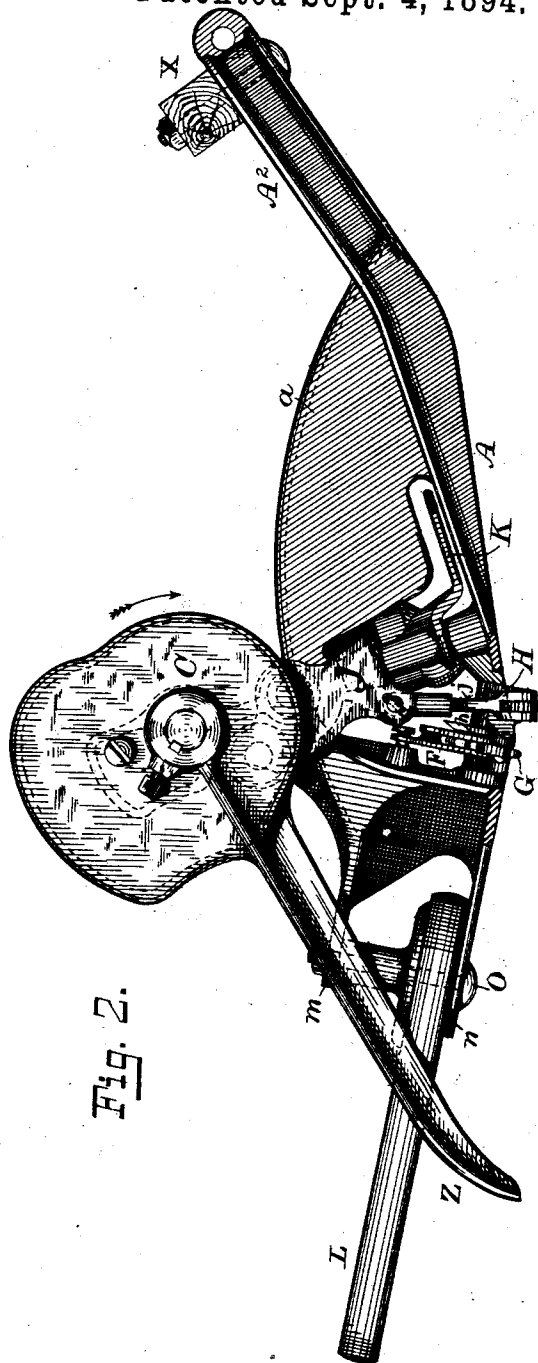

Fig. 2.



Witnesses:

Oscar C. Perrigo
Fred State

Inventors:

William N. Whiteley
William Bayley

W. N. WHITELEY & W. BAYLEY.
KNOTTER FOR GRAIN BINDERS.

No. 525,672.

Patented Sept. 4. 1894.

Fig. 5.

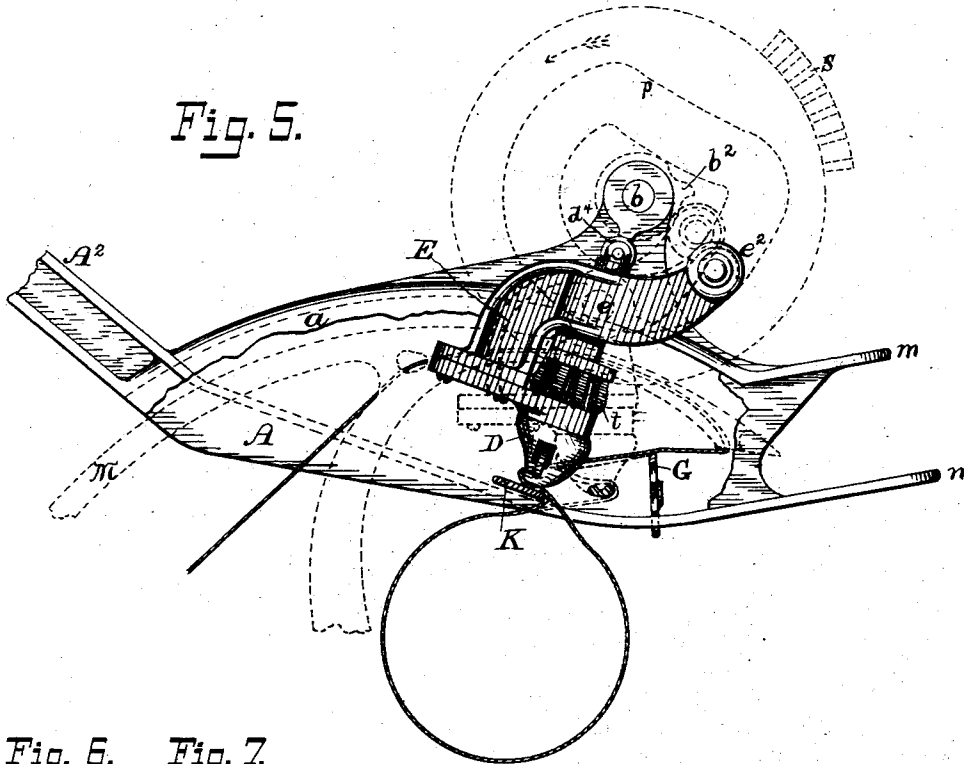

Fig. 6.

Fig. 7.

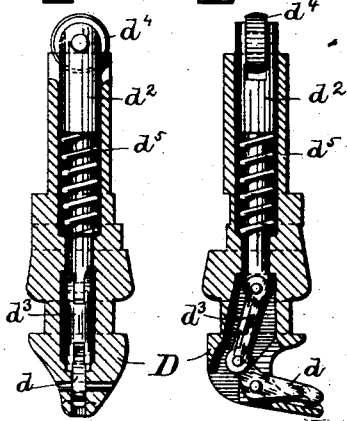
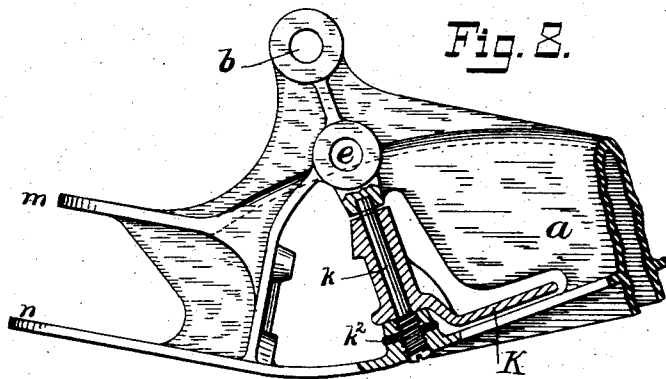

Fig. 8.



Witnesses:

Oscar E. Perrigo,
Fred State.

Inventors:

William N. Whiteley,
William Bayley

(No Model.)

5 Sheets—Sheet 4.

W. N. WHITELEY & W. BAYLEY.
KNOTTER FOR GRAIN BINDERS.

No. 525,672.

Patented Sept. 4, 1894.

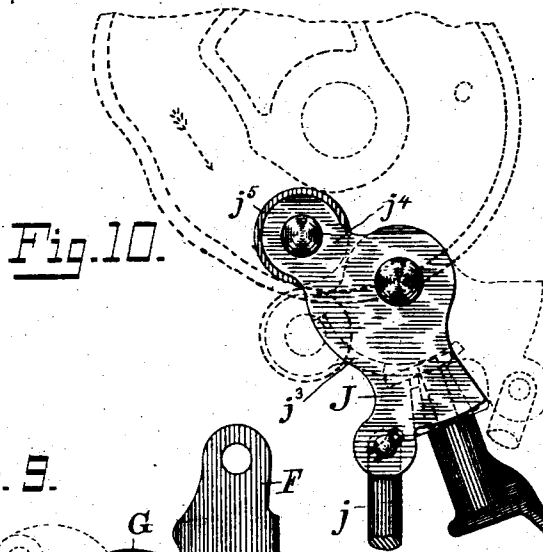

Fig. 10.

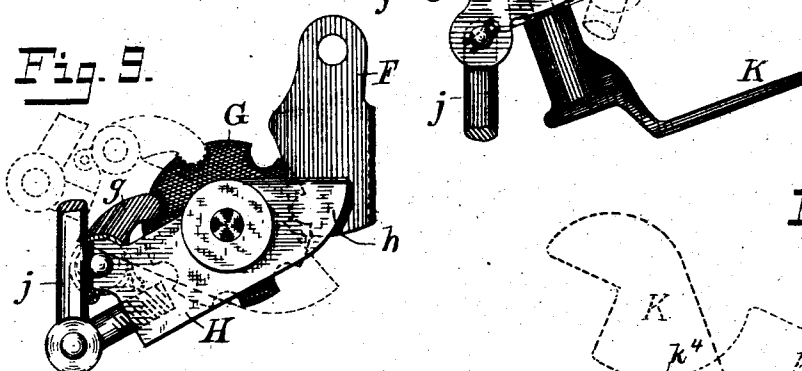

Fig. 9.

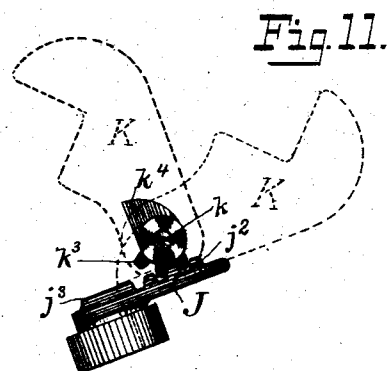

Fig. 11.

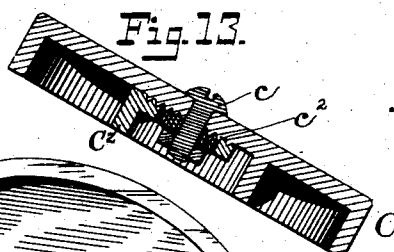

Fig. 13.

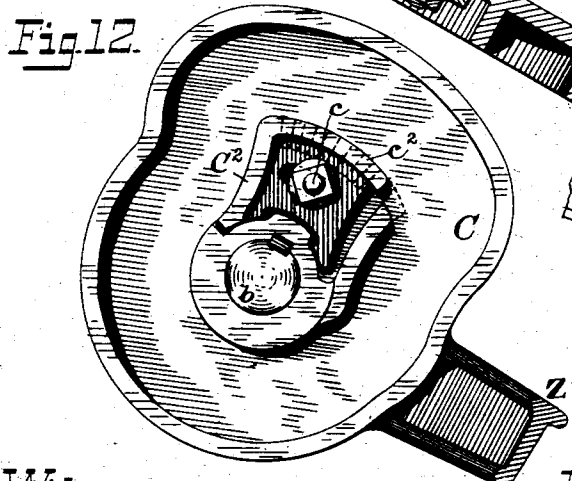

Fig. 12.

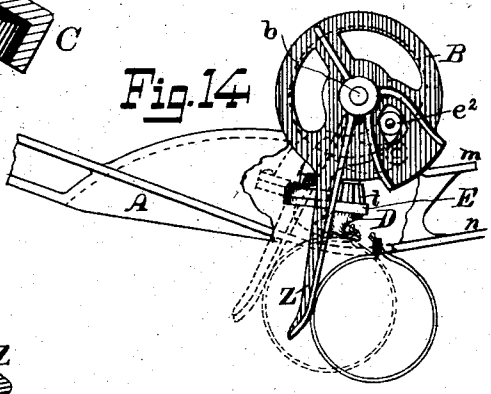

Fig. 14.

Witnesses:
Oscar E. Perrigo?
Fred State.

Inventors:
William N. Whiteley
William Bayley.

(No Model.)

5 Sheets—Sheet 5.

W. N. WHITELEY & W. BAYLEY.
KNOTTER FOR GRAIN BINDERS.

No. 525,672.

Patented Sept. 4, 1894.

Fig. 15.

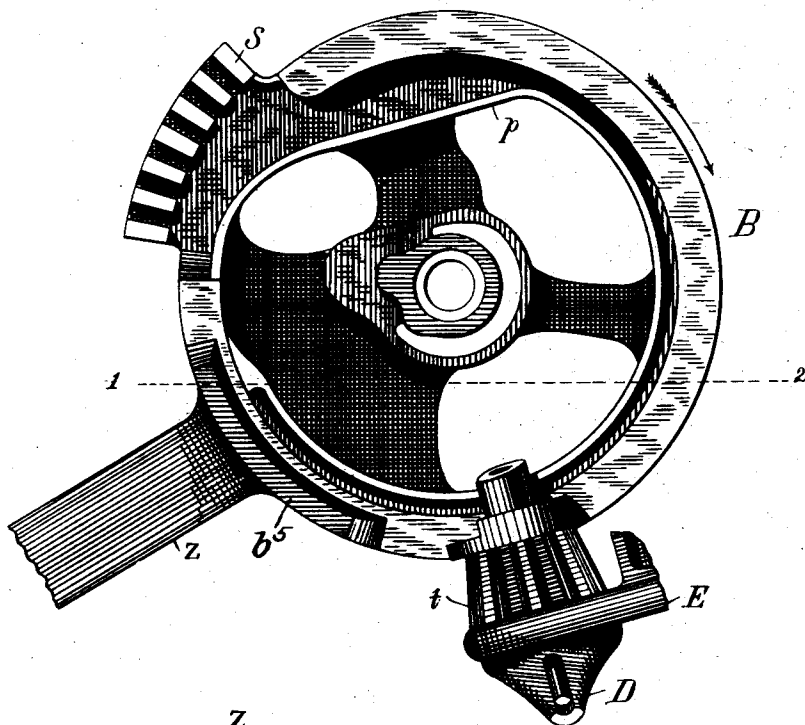

Fig. 16.

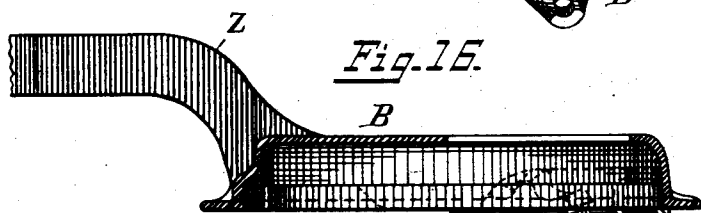

Fig. 17.

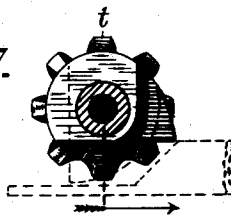

Fig. 18.

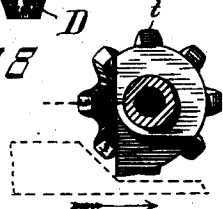
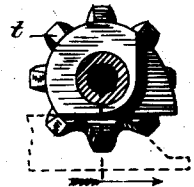

Fig. 19.



Witnesses:

Fred State
L. R. Nourse.

Inventors:

William Whiteley
William Bayley

UNITED STATES PATENT OFFICE.

WILLIAM N. WHITELEY AND WILLIAM BAYLEY, OF SPRINGFIELD, OHIO,
ASSIGNORS TO SAID WHITELEY.

KNOTTER FOR GRAIN-BINDERS.

SPECIFICATION forming part of Letters Patent No. 525,672, dated September 4, 1894.

Application filed November 1, 1886. Serial No. 217,679. (No model.)

To all whom it may concern:

Be it known that we, WILLIAM N. WHITELEY and WILLIAM BAYLEY, citizens of the United States, residing at Springfield, in the county of Clark and State of Ohio, have invented certain new and useful Improvements in Knotting Mechanism for Grain-Binders; and we hereby declare the following to be such a full, clear, and exact description of the invention as will enable any person skilled in the art to which it pertains to construct and use the same, reference being had to the accompanying drawings, forming a part of this specification.

Our invention relates to that class of automatic grain binding harvesters wherein the cut grain is delivered upon an inclined binding deck, where it is formed into a gavel and encircled by the binding cord by proper devices, after which the binding cord is automatically tied and that surrounding the bundle severed from the remaining cord, and the bundle discharged.

Our invention consists in certain devices and combinations whereby the knot is formed, the cord severed and the knot stripped from the tying device; and is in the nature of an improvement upon the knotting mechanism described in Letters Patent No. 212,420, granted to J. F. Appleby February 18, 1879, with the various modifications thereof in general use.

The new features of our invention are hereinafter fully described and particularly pointed out by the claims. These several novel features are illustrated in the drawings hereto attached, in which—

Figure 1, is a side elevation showing the knotter-hook, tyer-wheel, &c. Fig. 2, is an elevation of the opposite side, showing the cord-holder, tucker-finger, their operating cam, &c. Fig. 3, is a plan of the complete knotter. Fig. 4, is a plan of the breast-plate, tucker-finger, &c. Fig. 5, is a side elevation illustrating the swinging arrangement of the knotter-hook, &c. Fig. 6, is a vertical section through the knotter-hook, looking from the rear. Fig. 7, is a similar section looking from the side. Fig. 8, is a side elevation of a portion of the frame, showing in vertical section, the arrangement of the tucker-finger shaft, &c. Fig. 9, is a front elevation of the

cord-holding and cord-severing device. Fig. 10, is a side elevation of the toothed segment for operating the tucker-finger and cord-holder disk. Fig. 11, is a plan of the toothed segment and tucker-finger gear. Fig. 12, is an inside view of the adjustable cam for operating the toothed segment. Fig. 13, is a cross section through the same, showing the method of holding the adjustable part thereof in place; and Fig. 14, is a side elevation showing the knotter-hook and accessories, showing the manner of stripping the knot. Figs. 15 to 19 are detail views illustrating the various relative positions of the tyer wheel and pinion.

Similar letters refer to like parts in the several views.

In the drawings A, is a casting constituting the breast-plate and knotter frame formed in one piece, having the usual projection A², for fixing it to the binder girt X. Formed in the frame A, is the needle-arm case *a*, within which the needle-arm passes as it encircles the sheaf with the binding cord and lays the latter in place across the knotter-hook. The binder shaft *b*, passes through a proper perforation at the top of the frame in the usual manner and has the tyer-wheel B, fixed to it at one side of the frame A, and an additional cam-wheel C, at the other. Each of these cam-wheels has an ejector arm Z, formed upon it.

The knotter-hook D, is journaled in the swinging carrier E, which is pivoted to the frame A, at *e*, and has an arm formed upon it carrying the friction roller *e*², which engages a cam-track formed in the tyer-wheel B, for the purpose of swinging the knotter-hook toward the cord-holder as the former rotates in order to furnish slack cord for forming the knot and backward to assist in stripping the knot from the knotter-hook. This device is shown in detail in Fig. 5.

The pivoted jaw *d* of the knotter hook is opened and closed by a plunger *d*², working vertically through the knotter-hook stem and connected to the pivoted jaw *d* by a link *d*³, as shown in Figs. 6 and 7. Pivoted in the top of the plunger *d*², is a friction roller *d*⁴, which engages the cam *b*², formed on the hub of the tyer-wheel, and the knotter-hook tongue is

opened thereby and closed by the spiral spring d^5 , surrounding the plunger d^2 , and within the knotter-hook stem in the usual manner.

5 The cord-holder F, and cord-holder disk G, are pivoted to the frame and the cord-holder provided with the spring f , in the usual manner. Upon the same stud on which the cord-holder disk G, turns is also pivoted the lever
10 H, upon one end of which is formed, or fixed the cord-severing knife h , while upon the opposite end is pivoted the pawl g , which rotates the cord-holder disk G. The lever H, is operated by the toothed segment J, to which
15 it is connected by the rod j , which is made in two parts, one screwing into the other as shown in Figs. 1, and 2, for the purpose of rendering it adjustable as to its length. The cord-holding and severing device is shown in
20 detail in Fig. 9.

The tucker-finger K, is formed as shown in Figs. 2, 4, and 8, and pivoted upon the pivot-bolt k , which is threaded where it passes through the lower portion of the frame A, and
25 its upper end reaching the depth of the hole in the upper part of the frame A, as shown in Fig. 8. This mode of construction is adopted for the purpose of spreading the two bearings of the pivot bolt k , so that the tubular
30 part of the tucker-finger shall not "bind" and become immovable by any strain which tends to force these two bearings together. When properly adjusted the pivot-bolt k , is secured by the pin k^2 .

35 The tucker-finger is operated by the toothed segment J, having teeth j^2 , formed thereon, which engage the teeth k^3 , formed on the upper end of the tubular bearing of the tucker-finger K, as shown in Figs. 10, and 11. Upon
40 the back of the toothed segment J, is also formed a cam-track or delay rim j^3 , which engages the projection k^4 , and holds the tucker-finger K, in position after it has "tucked" the cord under the knotter-hook as hereinafter described. The toothed segment J, has
45 formed upon it a projection j^4 , which carries the friction-roller j^5 which engages the cam-track of the cam-wheel C, by which it is actuated.

50 The cam-wheel C, shown in detail in Figs. 12, and 13, is so arranged that the "throw" of the cam is adjustable, a portion C^2 , of the cam-track being made in a separate piece and held in place by the adjusting bolt c . Formed
55 upon each of the parts are V-shaped teeth c^2 , fitting each other, which assist the adjusting-bolt c , in holding the parts in place. By this means the part C^2 , of the cam-track may be adjusted so as to throw the tucker-finger K,
60 forward sooner or later in relation to the movements of the needle-arm and knotter-hook in order to properly place the cord on the latter for tying the knot.

The sheaf-guiding board L, has fixed to it
65 the plate l , by which it is pivoted to the projections m , n , of the frame, by the bolt O. By this arrangement, in the operation of the

harvester or in driving past obstructions, should the sheaf-board L, be accidentally struck, it will simply turn out of place, as
70 shown by dotted lines in Fig. 3, and will be thrown back to its proper position by the ejector on the tyer-wheel B, at its next revolution.

The operation of our invention is as follows, viz:—The parts of the knotter being in the positions shown in Figs. 1, 2, 3, &c., the
75 needle-arm M, advances, carrying the binding-cord across the knotter-hook and over the cord-holder disk as shown in Fig. 5. The
80 tyer-wheel rotates, in direction of the arrow, carrying with it the cam-wheel C, which actuating the toothed segment J, throws the tucker-finger K, around under the knotter-hook, and forcing the binding cord into the
85 position shown. Thus far the toothed segment J, has not moved far enough for the rod j , to cause any movement of the lever H, but continuing its rotation in direction of the arrow, the delay-rim j^3 , engages the projection
90 k^4 on the tucker-finger and holds it in the position shown in Fig. 5, while the segment J, is carried around far enough to cause the rod j , to lift the outer end of the lever H, by which the pawl g , rotates the cord-holder disk G, the
95 parts taking the positions shown in dotted lines in Fig. 9, and the cord being properly grasped and held as usual. The rotation of the tyer-wheel continuing, in direction of the arrow, the teeth S, thereon engage the teeth
100 of the knotter-hook pinion t , and rotate it in direction of the arrow in Fig. 4. At the same time the incline p , of the tyer-wheel cam-track acts upon the friction roller e^2 , and the knotter-hook carrier E, swings back to the position
105 shown by dotted lines in Fig. 5, by which operation sufficient length of binding-cord is supplied to form the knot. During the rotation of the knotter-hook the cam b^2 , has depressed the plunger d^2 , and opened the knotter-hook to grasp the second folds of the cord,
110 and the knot is formed. In the meantime the cam-track on the cam-wheel C, acts upon the friction roller of the segment J, bringing it back to the position shown in Fig. 10, thus
115 returning the tucker-finger to its original position and at the same time forcing the knife h , up against the binding-cord and severing it, these parts then taking the position shown in Fig. 9. The usual delay-rim formed upon
120 the tyer-wheel to prevent the rotation of the knotter-hook in either direction, except when acted upon by the teeth provided for that purpose, is cut away at b^5 (Fig. 15) the point upon the tyer-wheel which is now opposite
125 the knotter-hook, by which the latter is allowed to turn slightly backward as shown at r , Fig. 4, and at D, Fig. 14, the successive positions of the knotter pinion being shown in Figs. 17, 18, 19 and 15 immediately after which
130 ejectors Z, Z, come in contact with the bundle and force it outward, tending to strip the knot from the knotter-hook, which is still further facilitated and completed by the knot-

ter-hook swinging away from the bundle as it is ejected—that is, the knotter-hook swings in an opposite direction from the motion of the bundle. This is illustrated in Fig. 14, in which the bundle is shown in dotted lines, the knotter, with the knot formed on the knotter-hook D. After the knot is stripped from the knotter-hook by the bundle and knotter-hook moving in opposite directions, the latter taking the position shown by dotted lines and the cord shown by full lines.

Having thus described the construction, arrangement and operation of our invention and pointed out wherein it differs from the usual devices employed for similar purposes, and without wishing to be understood as restricting our claims of invention to any precise form or proportion of parts, or to any particular devices not essential to the principles of construction and mode of operation herein described,

What we claim as new, and desire to secure by Letters Patent, is—

1. In the knotting mechanism of an automatic grain binder the combination with the binder shaft, of a pivoted frame swinging in a plane parallel with the line of motion of the needle arm, a rotating knotter-hook journaled in said frame, gear-teeth and a delay rim carried by said binder shaft for actuating and controlling the knotter-hook, a cam which engages and operates the swinging frame at the proper times carried by the same shaft, a plunger for operating the knotter jaw, and a second cam on said shaft for depressing the plunger, substantially as set forth.

2. In the knotting mechanism of an automatic grain binder, having a pivoted frame swinging in a plane parallel with the movement of the needle arm, and a rotating knotting-hook journaled in said frame, the tucker finger K pivoted and adapted to swing under said hook in the same direction as the movement of the said swinging frame, gearing which swings the tucker finger in the said direction and in advance of the knotter hook, and delay devices substantially as described which maintain the tucker in said position during the tying of the knot, substantially as set forth.

3. In the knotting mechanism of an automatic grain binder, a tucker-finger pivoted upon a stationary shaft supported at each end in suitable bearings in the knotting frame, the said bearings being prevented from closing together and impeding the free working of the tucker-finger, by means of a cup shaped bearing into which the upper end of the shaft is forced by the lower end of the shaft being threaded and passing through a threaded hole at the lower end, the shaft being prevented

from turning after it is once adjusted, by a pin passing through the lower bearing and shaft, substantially as shown and described, and for the purposes set forth.

4. In the knotting mechanism of an automatic grain binder, a knotting frame, breast-plate and binder arm shield above the breast plate, formed of a single piece of cast metal and supporting the knot-tying mechanism, wherein the knot is formed by a rotating knotter-hook and suitable auxiliary parts, substantially in the manner and for the purposes shown and described.

5. In an automatic grain binder, a sheaf-board for guiding the bundle as it is discharged from the machine, the said board being vertically pivoted to the frame of the knotting mechanism, and swinging in a horizontal plane, for the purpose of allowing it to swing out of the way when encountering obstructions, substantially in the manner shown and described.

6. In an automatic grain binder, a sheaf-board for guiding the bundle as it is discharged from the machine, the said board being so pivoted to the frame of the knotting mechanism as to swing in a horizontal plane, for the purpose of allowing it to swing out of the way when encountering obstructions, in combination with an ejector arm so constructed and arranged as to move the said sheaf-board back into its proper position when the next bundle is discharged, substantially in the manner shown and described.

7. The combination with the pivoted tucker finger, and pivoted cord severing knife, of an oscillating plate geared with the tucker finger and a rod connecting said plate with the knife, substantially as set forth.

8. The combination with the tucker finger of the teeth k^3 , the projection k^4 , and the segment plate J having the teeth j^2 and the rim j^3 , substantially as set forth.

9. In the knotting mechanism of an automatic grain binder the combination with the binder shaft, of a pivoted frame swinging in a plane parallel with the line of motion of the needle arm, a rotating knotter hook journaled in said frame, gear teeth and a delay rim having a recess b^5 carried by said binder shaft for actuating and controlling the knotter hook, a knotter pinion having a delay surface and a cam, which engages and operates the said pivoted frame at the proper times, carried by the same shaft, substantially as set forth.

WILLIAM N. WHITELEY.
WILLIAM BAYLEY.

Witnesses:

OSCAR E. PERRIGO,
FRED STATE.