

C. G. BUCHANAN.
MAGNETIC ORE SEPARATOR.

No. 531,301.

Patented Dec. 25, 1894.

Fig. 1.

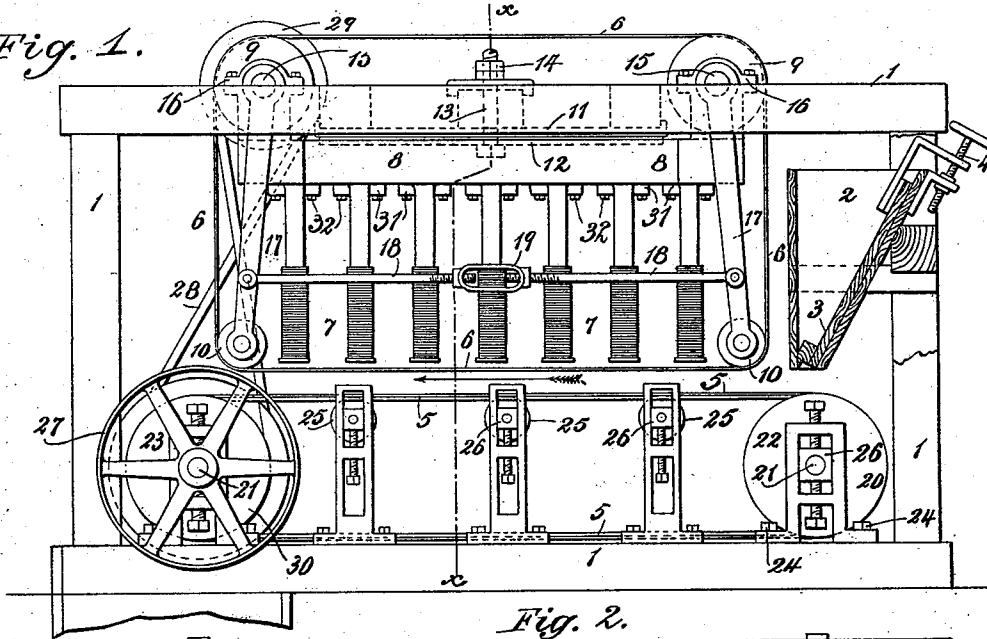
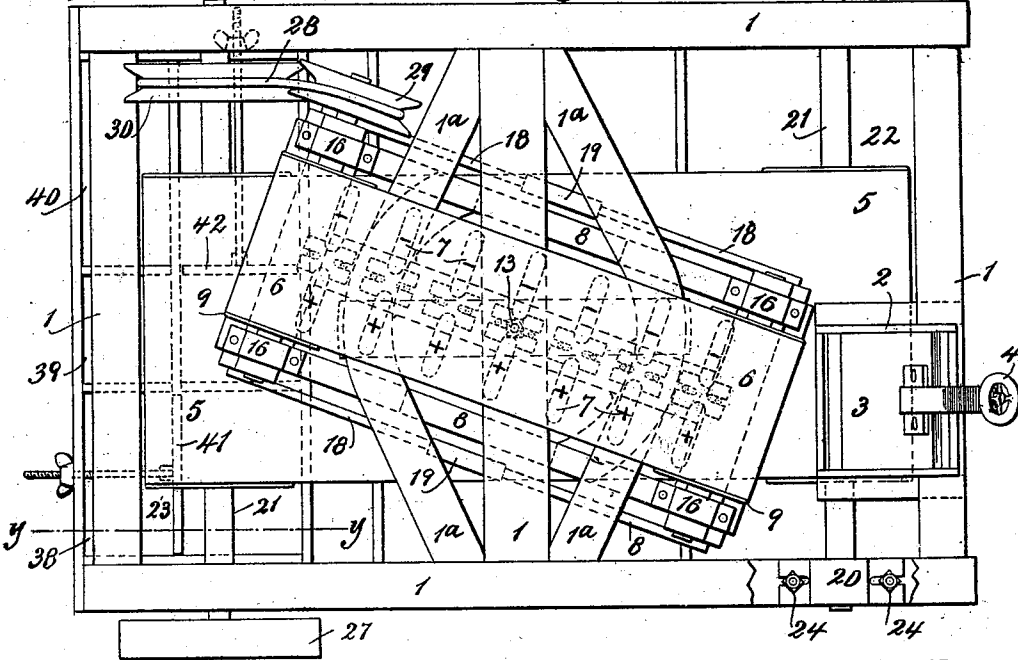

Fig. 2.



WITNESSES:
John M. Deemer
Henry L. Goodwin

INVENTOR
Charles G. Buchanan
 BY
Geo. H. Spurr
 ATTORNEY

C. G. BUCHANAN.
MAGNETIC ORE SEPARATOR.

No. 531,301.

Patented Dec. 25, 1894.

Fig. 3.

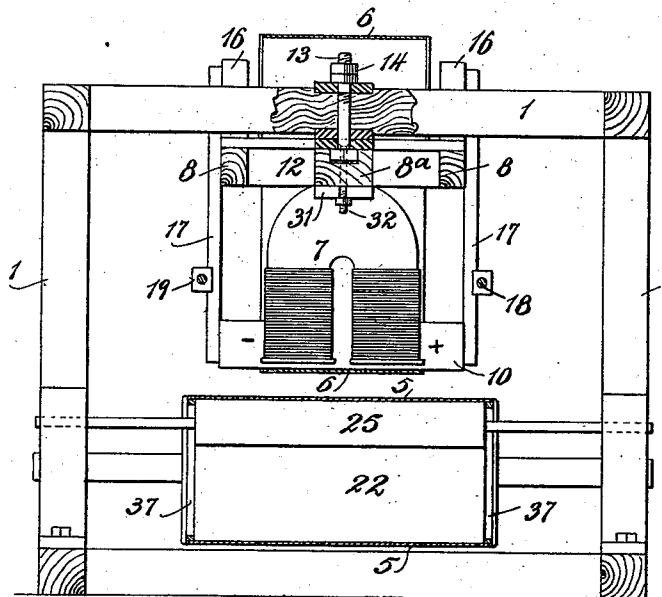

Fig. 4.

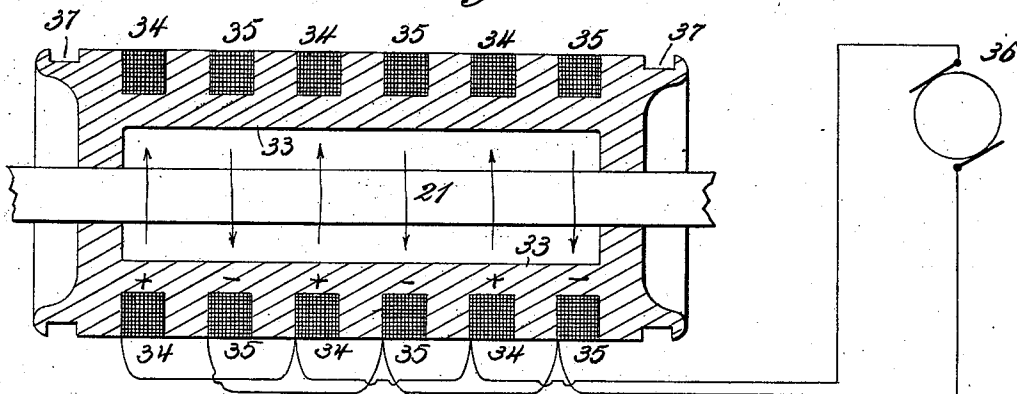
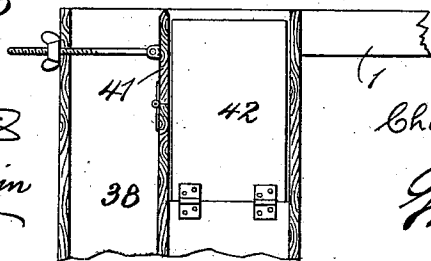

Fig. 5.



WITNESSES:
John H. Deemer
Henry L. Goodwin

INVENTOR
Charles G. Buchanan
 BY
Geo. H. Benjamin
 ATTORNEY

UNITED STATES PATENT OFFICE.

CHARLES G. BUCHANAN, OF NEW YORK, N. Y.

MAGNETIC-ORE SEPARATOR.

SPECIFICATION forming part of Letters Patent No. 531,301, dated December 25, 1894.

Application filed May 12, 1893. Serial No. 474,035. (No model.)

To all whom it may concern:

Be it known that I, CHARLES G. BUCHANAN, a citizen of the United States, residing at the city, county, and State of New York, have invented new and useful Improvements in Magnetic-Ore Separators, of which the following is a specification.

My invention relates to magnetic ore separators and has for its object to provide an improved apparatus of this character capable of quick and easy adjustments and adapted for operation with or upon all kinds of crushed ores susceptible to magnetic influence for effecting a graded separation of the heads, middlings and tailings in a simple and effective manner.

Generally speaking, the invention consists in the combination of an obliquely arranged endless belt traveling along the poles of magnets in the magnetic fields and at an acute angle relatively with another longitudinally moving endless belt upon which the crushed ores are fed and carried along beneath the oblique belt which will, by the influence of the magnets successively lift and drop particles of the ore thereby transferring the magnetites gradually over to one side of the carrier belt while the non-magnetic particles are moved straight along on the carrier belt to the tailings receptacle. A magnetic roll at the farther bight of the feeding belt effects a final separation and grading of the tailings, middlings and concentrates.

The invention will first be described and then will be particularly defined in claims hereinafter set forth.

Reference is to be had to the accompanying drawings, forming a part of this specification, in which like reference numerals indicate similar parts in the several views.

Figure 1, is a side elevation of my improved ore separator, partly broken away and in section. Fig. 2, is a plan view thereof adjusted for action and partly broken away. Fig. 3, is a transverse vertical section taken on the line x, x , in Fig. 1. Fig. 4, is an enlarged longitudinal sectional view of the magnetic roll which effects final separation and grading of the ores, and Fig. 5, is a detail longitudinal vertical section of the graded ore receptacles taken on the line y, y , in Fig. 2.

In the preferred construction, I use a main

frame 1, which supports the operative parts of the apparatus which comprise a hopper 2, receiving the crushed ores and having a gate 55 or valve 3, operative by a hand wheel 4; or any other suitable device may be used to control feeding of the ore upon an endless belt 5, which travels along beneath an upper endless belt 6, moving along the poles or in the 60 magnetic fields of a series of magnets 7, sustained in or by an obliquely adjustable frame 8, which supports the rotating drums or rollers 9, 9, 10, 10, on which the belt 6, moves. The frame 8, may be swiveled to the main 65 frame 1, in any approved manner.

I show a metal plate 11, held to the under sides of the three central head cross timbers of the frame 1, and segmental plates 12, held to the frame 8, and constituting with the plate 70 11, a sort of fifth wheel through which passes the king bolt 13, by or upon which the frame 8, is supported. Jam nuts 14, on the bolt provide for fastening the magnet holding frame 8, to keep its traveling belt 6, at any desired 75 obliquity relatively to the lower carrier belt 5.

The upper drums 9, 9, are held to shafts 15, 15, which are journaled in bearings 16, 16, bolted to the frame 8, while the lower drums or rollers 10, 10, are journaled in the lower 80 ends of pendent arms 17, 17, which are hung loosely on the upper shafts 15, 15, and are coupled in pairs at opposite sides of the magnet carrying frame by rods 18, 18, screw-threaded to a turnbuckle 19, whereby the 85 lower ends of the arms 17, and consequently the two lower rollers 10, 10, may be separated by turning up the buckles 19, to keep the upper belt 6, always tight and cause it to travel as near as may be to the poles of all the mag- 90 nets 7, without touching them. The bearings 20, of the shafts 21, of the rolls or drums 22, 23, of the lower carrier belt 5, are slotted to receive their fastening bolts 24, thus permitting separation of the shafts 21, and the rolls 95 to keep the belt tight and allow its upper side to travel in horizontal parallelism with the lower side of the belt 6. Bed rollers 25, support the upper side of the carrier belt and prevent its sagging under weight of ore fed 100 to it from the hopper. The shafts of the belt rolls 22, 23, and also of the bed rollers 25, are fitted in vertically adjustable boxes 26, permitting adjustment and support of the upper

side of the carrier belt 5, at any desired distance from the belt 6, as the different kinds or grades of ore operated upon may require.

The adjacent opposing sides of the belts 5, 6, travel in the same direction toward the delivery or discharge end of the machine, and as indicated by the arrow in Fig. 1, of the drawings. The carrier belt 5, is operated from a pulley 27, belted to any convenient motor, while the upper belt 6, is actuated by a crossed belt 28, which gives motion to a pulley 29, on one of the drum shafts 11, from a pulley 30, on the shaft of the magnetic roll 23, which carries the pulley 27. The central head timbers 1^a, 1^b, of the main frame 1, are bowed or shaped so as to give necessary clearance to the belt 6, and its driving gearing at maximum oblique adjustment of the magnet and belt carrying frame 8, and as shown in Fig. 2 of the drawings. The belts 5, 6, are made of rubber, canvas, or it may be any other material which will allow the magnets 7, and the magnetic roll 23, to attract the magnetites without themselves becoming magnetized.

The magnets 7, are here shown as of the ordinary horseshoe type but having at the bends slotted lugs 31, through which pass, into the central longitudinal timber 8^a, of the frame 8, the screws or bolts 32, by which the magnets are hung to the frame in a manner allowing them to be adjusted and clamped at any required distances apart to properly control their magnetic fields to cause successive lifting and dropping of the magnetites from and to the carrier belt 5, during operation. Any form of either permanent or electro magnets may however be used, and the electro magnets may be energized in any known or approved manner.

The magnetic roll 23, over which the delivery end of the carrier belt 5, passes is preferably made as shown more clearly in Fig. 4, of the drawings, or with a central iron cored casting 33, fixed at its ends to the shaft 21, and provided with a series of peripheral grooves receiving the insulated wire windings 34, 35, which are coiled in reverse directions as indicated by the arrows and are coupled in series and are connected to the brushes of a dynamo 36, which will generate in the coils a strong current giving necessary attraction of the roll for the magnetites carried by the belt 5, to the discharge end of the apparatus. This roll might be wound in any other way, however, as this point is immaterial; the only object being to obtain as strong a current as possible in the coils thereof. The only function of this carrier roll is to separate from the non-magnetic particles any slightly magnetic material or magnetites that may have been accidentally carried past the field of force of the electromagnets and deliver said magnetic particles at the lowermost portion of the face of the roll into a suitable receptacle, while the rock falls by gravity from the sides of the roll or is thrown off by tangential force. At each

end the magnetic roll 23, as also the guide roll 22, has a peripheral groove 37, receiving an inwardly projecting flange or strip on the carrier belt 5, thereby preventing lateral slip or displacement of the belt. The upper guide rolls or drums 9, 9, also have suitable flanges preventing lateral displacement of the upper belt 6.

The operation is as follows: It will appear from Fig. 2, of the drawings that the hopper 2, is only about one half the width of the carrier belt 5. Hence the crushed or pulverized ore fed from the hopper will fall in a thin layer upon the belt 5, directly in front of the rear end of the moving belt 6, on the frame 8, which will be set at proper oblique position relatively to the belt 5, to assure the best action of the magnets 7, on the ore to cause the magnetites it contains to be lifted and dropped a maximum number of times. As the ore on the belt 5, approaches the first magnet 7, on the frame 8, the magnet will attract the magnetites to the belt 6, which by traveling obliquely will carry them forward and over toward the right hand side or half of the carrier belt and said magnetites will fall from the belt 6, when carried beyond the field of attraction of the first magnet 7. As each successive magnet 7, operates in like manner the magnetites will be successively lifted from and dropped again to the carrier belt and the purest magnetites or "heads" will be lifted and dropped the greatest number of times, and consequently will be carried over farthest upon and toward the right hand side or edge of the belt 5, while those less rich or the "middlings" will take an intermediate lateral position while the non-magnetic and less rich particles or "tailings" of the ore which are not lifted from the carrier belt will travel straight along the left hand half or side of this belt until they reach the magnetic roll 23, which effects a final separation of the "tailings," "middlings" and "heads" which are discharged from the carrier belt into their respective receivers 38, 39, 40. It will therefore be seen that while the attractive force exerted by the magnets is or may be constant, the intermittent lifting and dropping of the magnetic particles is caused by the peculiar relative arrangement of the two belts and the magnets, whereby these particles are carried through isolated fields of force of the successive magnets by means of the oblique belt drawing the lifted particles out of the field of each magnet, while the carrier belt draws the dropped particles into the field of the next succeeding magnet. A longitudinally swinging gate or valve 41, and a laterally swinging gate or valve 42, are adjustable by hand for promoting the closest possible grading of the ores falling from the carrier belt into the receivers.

The frame 8, with its magnets 7, and belt 6, will be set at any required obliquity relatively to the carrier belt 5, to produce the best separating effect on different grades of ores,

and as may be quickly determined by experiment.

It will be seen from Figs. 1 and 2, of the drawings that the positive poles of the magnets are all arranged at or toward one side of the frame 8, and its belt 6, which is the plan preferred at present, but an alternate disposition of the magnetic poles may be adopted within the scope of my invention.

I am aware that it is not new to cause an ore lifting belt traveling along series of magnets, to traverse above and about at right angles to an ore carrying belt during magnetic separation of the ore. My invention however, differs materially in practice from that above named by reason of the traverse of the upper lifting and dropping belt obliquely or at an acute angle relatively to the line of travel of the lower carrier belt, as thereby the action of the magnets in successively attracting and releasing the ore particles is materially prolonged for a given area of upper belt and speed of belt travel than is possible when one belt crosses the other at right angles. In other words, in my apparatus, and for a given area of upper belt and speed of travel of the belts, the magnetite ore particles are within the influence of magnetic attraction for a much longer time and therefore are more thoroughly agitated due to the ore lifting and dropping belt traversing the carrier belt obliquely at an acute angle. Hence the separation is more closely and thoroughly effected.

The speed of travel of the two belts may be varied relatively to each other as any particular grade of ore may require.

The terms "horizontal" and "horizontally" as applied to the belts 5, 6, are to be liberally construed to include any planes of travel of the belts permitting operation of the apparatus substantially as above described.

I claim as my invention—

1. A magnetic ore separator constructed with a carrier belt, an opposing belt moving obliquely thereto, and a series of magnets whose poles face the oblique belt, all arranged substantially as described, whereby the conjoint action of the belts and magnets will cause the magnetic particles to be alternately lifted from the carrier belt to the oblique belt and be dropped therefrom to the carrier belt as said particles are carried by the two belts through the fields of force of the successive magnets during traverse of ore through the machine, as herein set forth.

2. In a magnetic ore separator, the combination of two horizontal moving belts occupying parallel horizontal planes and whose direction of motion is oblique to each other, and means for varying the angle included between the respective axes of movement of the two belts.

3. A magnetic ore separator constructed with a carrier belt, a second belt arranged with its lower traveling side above and obliquely to the carrier belt, and a series of magnets arranged in the bight of the upper belt

with their poles facing the lower side thereof, substantially as described, whereby the conjoint action of the belts and magnets causes the oblique belt to draw the lifted particles out of the field of each magnet, while the carrier belt draws the dropped particles into the field of the next succeeding magnet, as herein set forth.

4. A magnetic ore separator comprising a carrier belt, an opposing belt traveling obliquely thereto and adjustable to different angles relatively to the carrier belt, and magnets next the oblique belt, substantially as described.

5. A magnetic ore separator comprising a carrier belt, an opposing belt traveling obliquely thereto, and a series of independent magnets next the oblique belt and coinciding in direction therewith, said belts being relatively adjustable to bring their opposing sides nearer to or farther from each other, substantially as described.

6. A magnetic ore separator constructed with a carrier belt, an opposing belt moving obliquely thereto, and a series of magnets whose poles face the oblique belt, said magnets adapted for adjustment to and from each other, and all arranged substantially as described; whereby the conjoint action of the belts and magnets will cause the magnetic particles to be alternately lifted from the carrier belt to the oblique belt and be dropped therefrom to the carrier belt as the particles are carried by the two belts through the fields of force of the successive magnets, and whereby also the degree or extent of isolation of the magnetic fields may be controlled by relative adjustment of the magnets, as herein set forth.

7. A magnetic ore separator comprising a carrier belt, a device feeding ore but part way across said belt, an opposing belt traveling obliquely to the carrier belt, and magnets next the oblique belt, substantially as described.

8. In a magnetic ore separator, the combination with a main frame, a carrier belt thereon, an upper auxiliary frame swiveled to the main frame, an oblique traveling belt on the upper frame, and magnets on said swiveled frame next the oblique belt, substantially as described.

9. In a magnetic ore separator, the combination with a main frame, a carrier belt thereon running at the discharge end over a magnetic roll, a device feeding ore but part way across the belt, an upper auxiliary frame swiveled to the main frame, an oblique traveling belt on the upper frame, and magnets on said swiveled frame next the oblique belt, substantially as described.

10. The combination in a magnetic ore separator, of a main frame 1, a carrier belt 5 thereon, an upper frame 8 swiveled to the main frame, drums 9, 9, and rollers 10, 10 on the frame 8, said rollers 10 being held to pivoted arms 17 connected by devices 18, 19; a belt 6 on the parts 9, 10, and magnets 7 on

the frame 8 facing the belt 6, substantially as described.

11. The combination in a magnetic ore separator, of a main frame 1, a carrier belt 5 5 thereon, an upper frame 8 swiveled to the main frame, drums 9, 9, and rollers 10, 10 on the frame 8, said rollers 10 being held to pivoted arms 17 connected by devices 18, 19; a 10 frame 8 facing the belt 6, and an ore feeding device 2, 3 delivering ore but part way across the carrier belt, substantially as described.

12. The combination in a magnetic ore separator, of a main frame, a carrier belt 5 15 running on a roll 22 and a magnetic roll 23, said rolls being journaled in vertically ad-

justable boxes 26 fitted in longitudinally adjustable bearings 20, an auxiliary frame 8 swiveled to the main frame, drums 9, 9, and rollers 10, 10 on the frame 8, said rollers 10 20 being held to arms 17 coupled by devices 18, 19, a belt 6 on the parts 9, 10, magnets 7 in the frame 8 facing the belt, and devices 2, 3 feeding ore but part way across the carrier belt 5, substantially as described.

In testimony whereof I affix my signature in the presence of two witnesses. 25

CHARLES G. BUCHANAN.

Witnesses:

TIMOTHY F. DILLON,
JOHN M. DEEMER.