

J. K. WOOD.

Improvement in Cutter-Heads for Moldings.

No. 130,684.

Patented Aug. 20, 1872.

Fig 1.

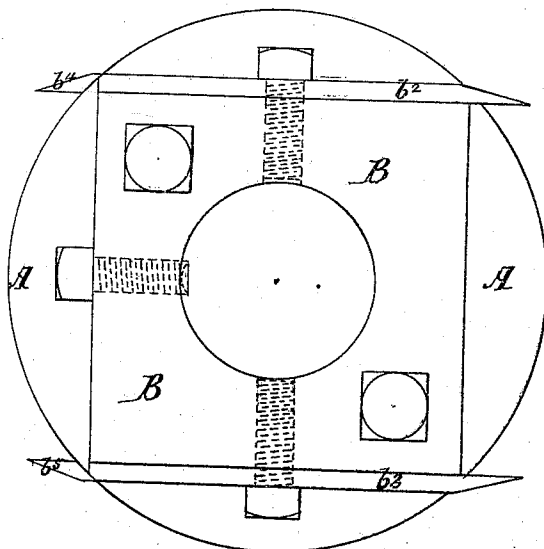

Fig 2.

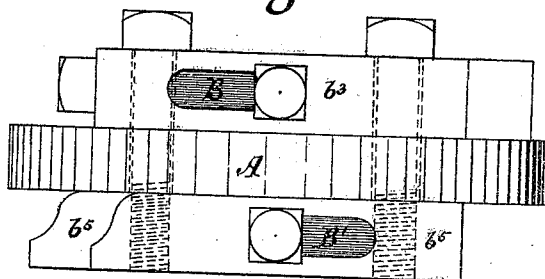

Fig 3.

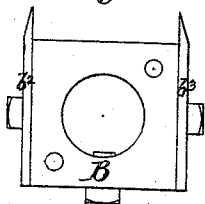
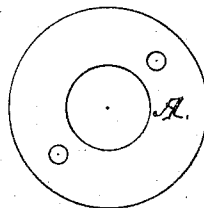

Fig 4.



Fig 5.



WITNESSES

E. Malcolm Turner
Jas. A. Mahaffey

INVENTOR

John K. Wood

UNITED STATES PATENT OFFICE.

JOHN K. WOOD, OF ALLEGHENY, PENNSYLVANIA.

IMPROVEMENT IN CUTTER-HEADS FOR MOLDINGS.

Specification forming part of Letters Patent No. 130,684, dated August 20, 1872.

SPECIFICATION.

To all whom it may concern:

Be it known that I, JOHN K. WOOD, of Allegheny City, in the county of Allegheny and State of Pennsylvania, have invented certain new and useful Improvements in Cutter-Heads for Moldings; and I do hereby declare that the following is a full, clear, and exact description thereof, reference being had to the accompanying drawing and to the letters of reference marked thereon which form a part of this specification.

My invention consists of a double-adjustable cutter-head, whereby circular sashes are rabbeted and molded at one and the same time.

In the accompanying drawing, Figure 1 is a plan of my invention, showing most of the devices used. Fig. 2 is a side elevation of same. Fig. 3 is a plan of a tool-carrier with cutters attached; Fig. 4, an end view of the central plate used as a guide. Fig. 5 is a plan of same.

A circular plate, A, of any desired thickness, and having an orifice in its center, is placed between two other square plates or tool-carriers, B and B', having suitable holes through them, corresponding to similar holes in plate A, through which are passed bolts for the purpose of holding them firmly in position. Said tool-carriers B and B' have also holes through their centers corresponding to the central orifice in plate A. To the sides of the tool-carrier B are attached adjustable straight-edged cutters b^2 and b^3 , and held in position by bolts passing through slots in their side into said tool-carrier B. These cutters b^2 and b^3 are so placed in position, with their cutting-edges reversed, as shown in Figs. 1 and 3 of the accompanying drawing, as to cut with the shaft rotating either way.

The molded cutters b^4 and b^5 are similarly attached to tool-carrier B', but placed in an opposite direction so as to balance the cutter-head.

My invention is operated in the following manner: When all the various parts of said cutter-head are in position, as above described, it is placed on an upright shaft with upper extremity projecting above the table so that the lower side of said cutter-head shall be flush or thereabout with the surface of said table. It is firmly secured to said upright shaft by thread-bolts screwed into tool-carriers B and B'. The sash-heads are then rabbeted and molded at one and the same time, the plate A serving as a guide, thereby dispensing with the ordinary pattern.

The tools or cutters, before described, may be of any desired shape or size, the whole being constructed of iron and steel.

My invention, though serviceable for working straight sashes, is particularly adapted for working circular and curved sashes. It is simple of construction, cheap, and far less dangerous to the operator than the ordinary cutter-heads now in use.

Having described my invention, what I claim as new, and desire to secure by Letters Patent, is—

The center plate A, used as a guide, in combination with tool-carriers B and B' and cutters b^2 , b^3 , b^4 , and b^5 , arranged substantially as described, and for the purpose set forth.

In testimony that I claim the foregoing as my own I affix my signature in presence of two witnesses.

JOHN K. WOOD.

Witnesses:

D. S. RAMSEY,
JAS. A. MAHAFFEY.