

(12) **UK Patent Application** (19) **GB** (11) **2570259** (13) **A**

(43) Date of Reproduction by UK Office **17.07.2019**

(21) Application No: **1907009.3**  
(22) Date of Filing: **18.05.2017**  
Date Lodged: **17.05.2019**  
(30) Priority Data:  
(31) **201710254531** (32) **18.04.2017** (33) **CN**  
(86) International Application Data:  
**PCT/CN2017/084793 Zh 18.05.2017**  
(87) International Publication Data:  
**WO2018/192042 Zh 25.10.2018**

(51) INT CL:  
**E02D 19/12** (2006.01) **E21B 33/13** (2006.01)  
(56) Documents Cited:  
**CN 205776263 U** **CN 202970767 U**  
**CN 106320728 A** **CN 105821894 A**  
**CN 105421475 A** **CN 105298518 A**  
**DD 000262887 A1**  
(58) Field of Search:  
INT CL **E02D, E21B**  
Other: **CNKI,CNABS,CNTXT**

(71) Applicant(s):  
**Jiangsu University**  
**301 Xuefu Road Zhenjiang, Jiangsu 212013, China**  
(72) Inventor(s):  
**Yun Wang**  
**Zhigang Jiang**  
**Ding Jiang**  
**Le Zhang**  
**Weijie Yu**  
**Zhenying Xu**  
**Suwen Lu**  
**Yan Yin**  
**Yuchun Zhao**  
(74) Agent and/or Address for Service:  
**Albright IP Limited**  
**County House, Bayshill Road, CHELTENHAM,**  
**Gloucestershire, GL50 3BA, United Kingdom**

(54) Title of the Invention: **Environmentally friendly capsular bag-type downhole karst cave blocking device and blocking method therefor**  
Abstract Title: **Environmentally friendly capsular bag-type downhole karst cave blocking device and blocking method therefor**

(57) Disclosed is an environmentally friendly capsular bag-type downhole karst cave blocking device, relating to the field of petroleum drilling, and mainly being used to block a downhole karst cave. The device comprises mechanical parts, such as a connecting rod, hinges (309, 310, 311), springs (407, 408), a one-way valve (204), a slide rail (102), a sensor (405), a ratchet and electromagnets (402, 404) in a combined transmission manner. The automatic karst cave blocking of the whole environmentally friendly capsular bag-type downhole karst cave blocking device is realized by means of a capsular bag. Further disclosed is an environmentally friendly capsular bag-type downhole karst cave blocking method. The device and method reduce the requirements for a leakage blocking material and a drill pipe, reduce the costs and time needed for blocking a karst cave, and can be used in large karst cave and honeycomb-shaped karst carve scenarios.

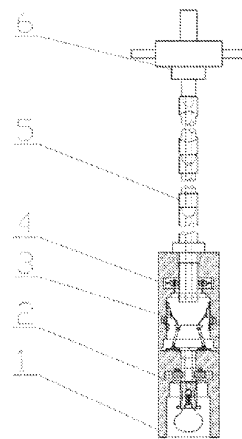


图 1

**GB 2570259 A**

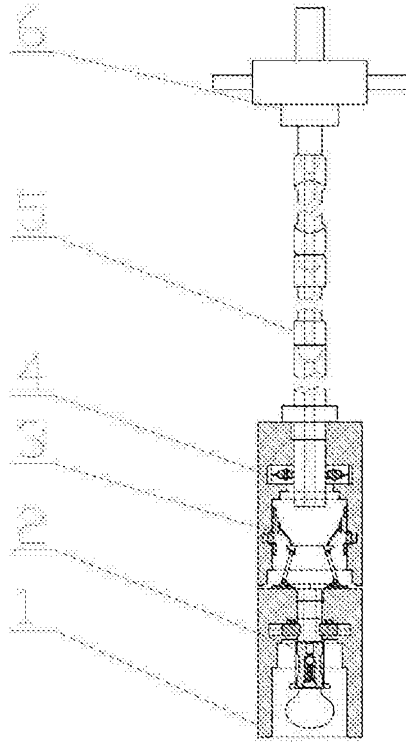


Fig. 1

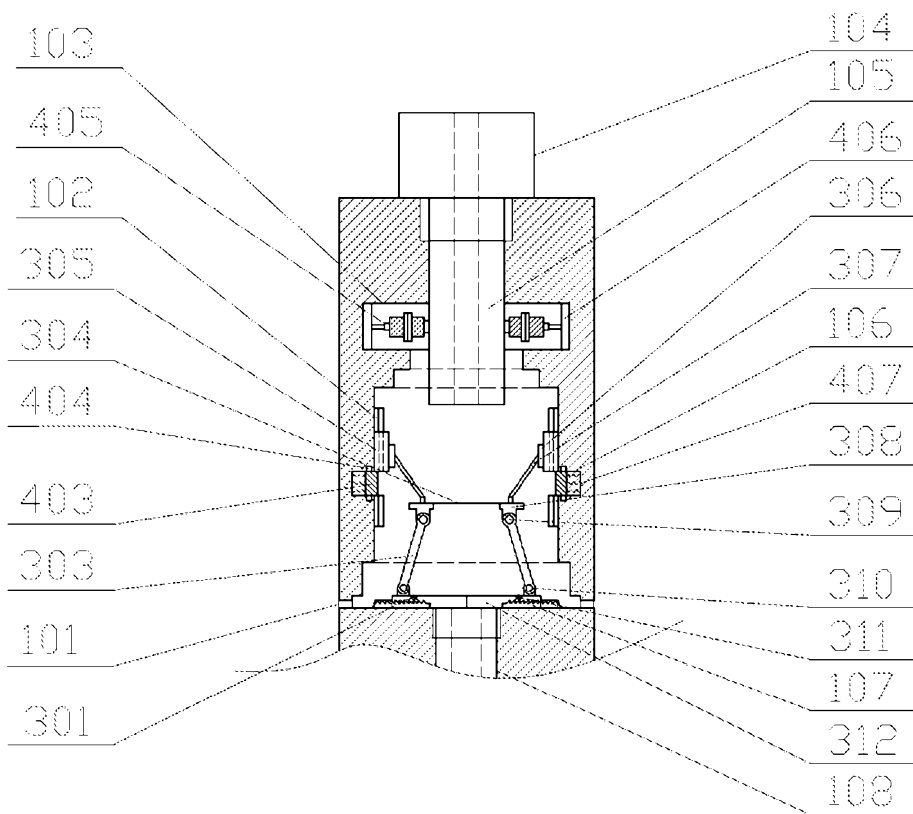


Fig. 2

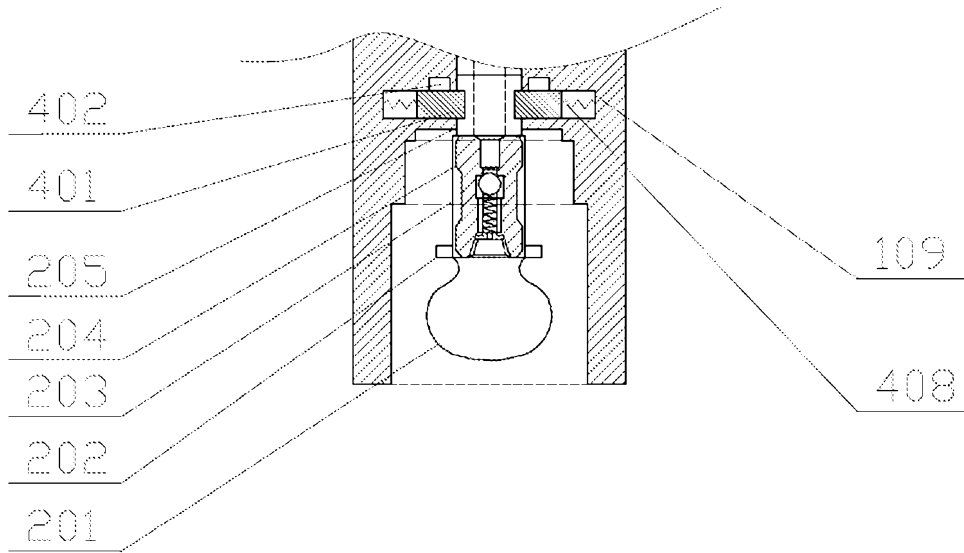


Fig. 3

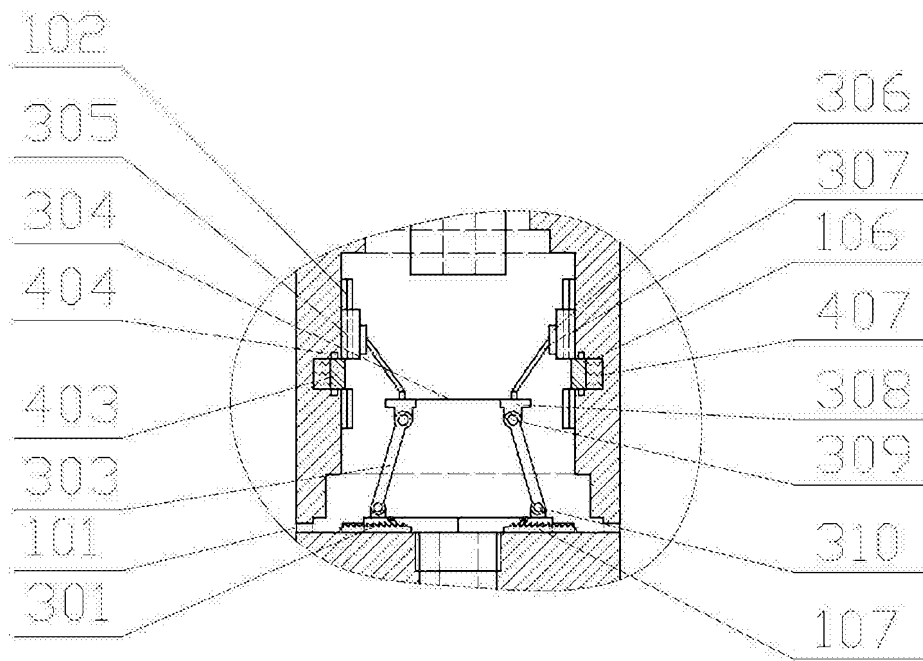


Fig. 4



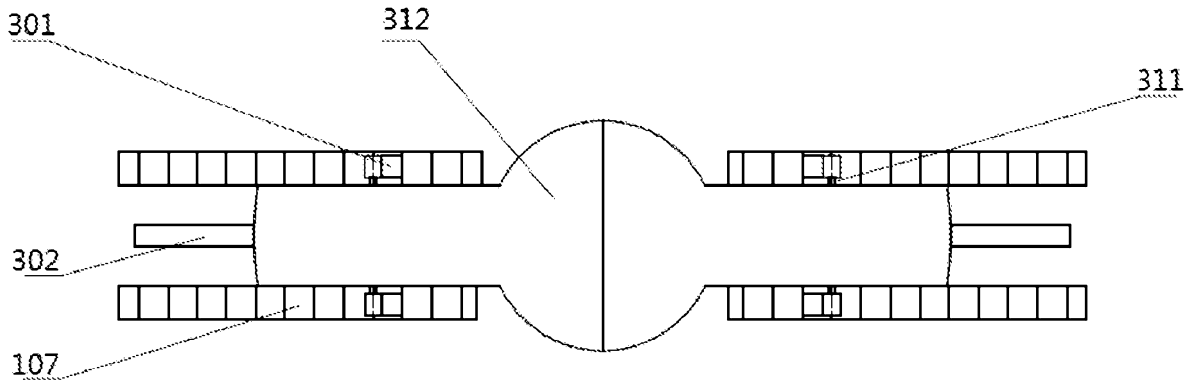


Fig. 7

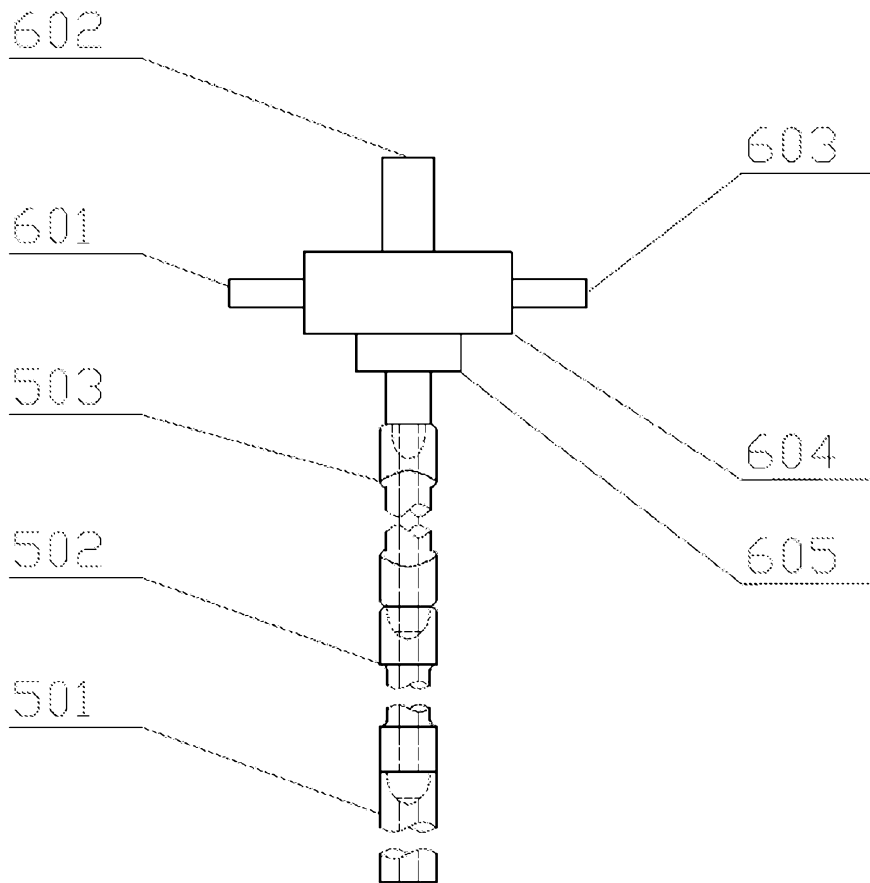


Fig. 8

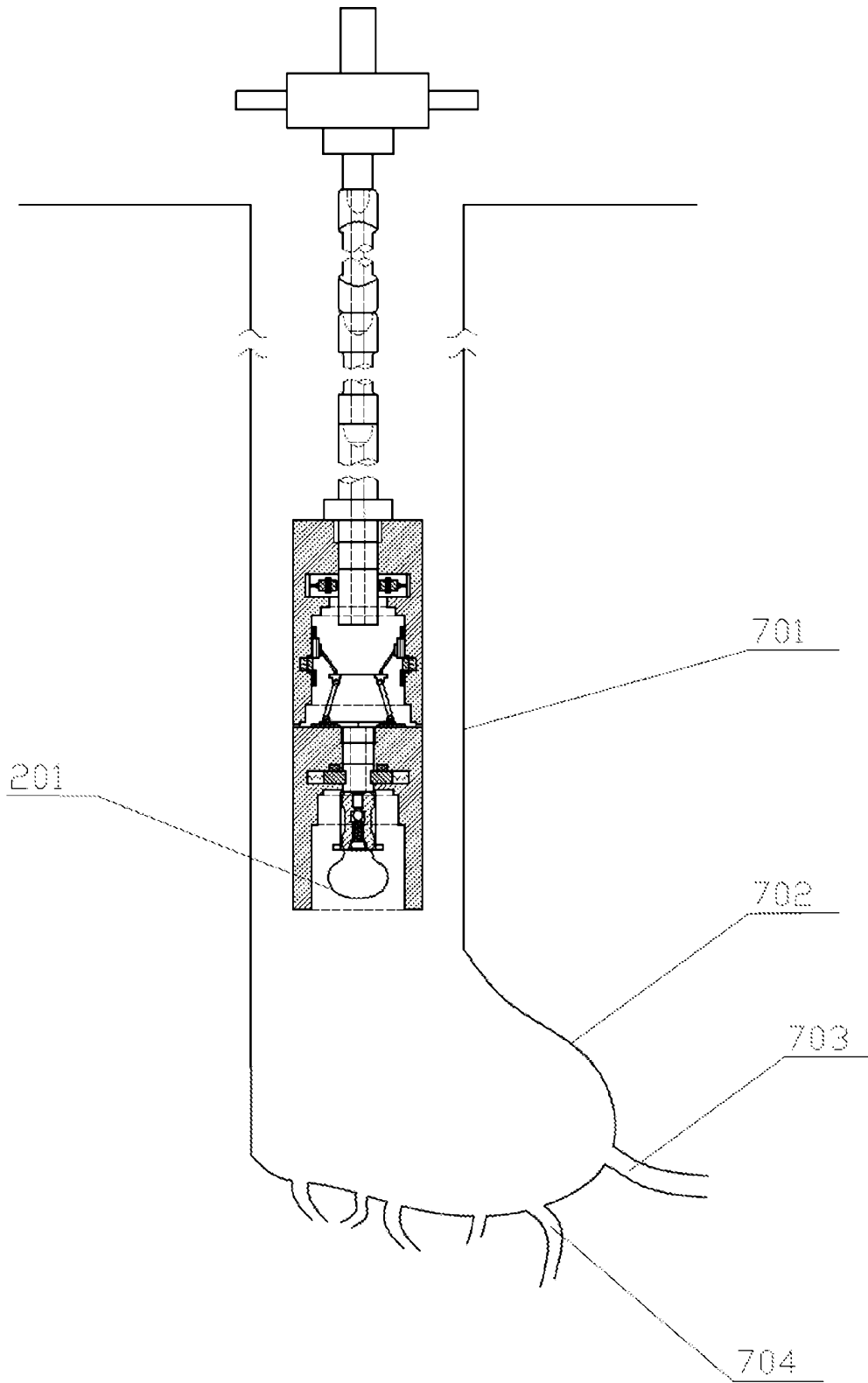


Fig. 9

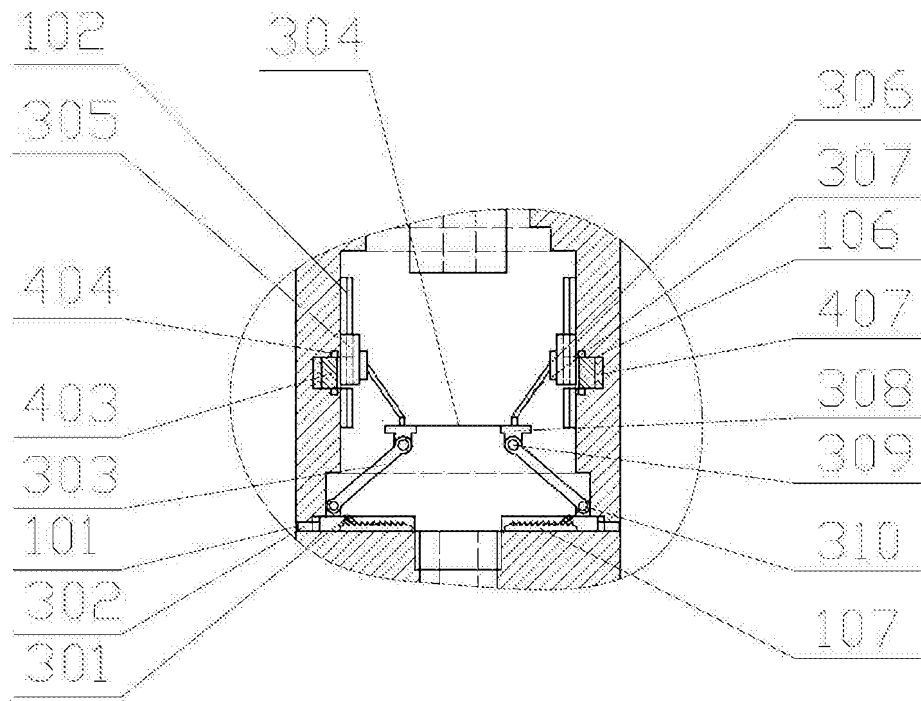


Fig. 10

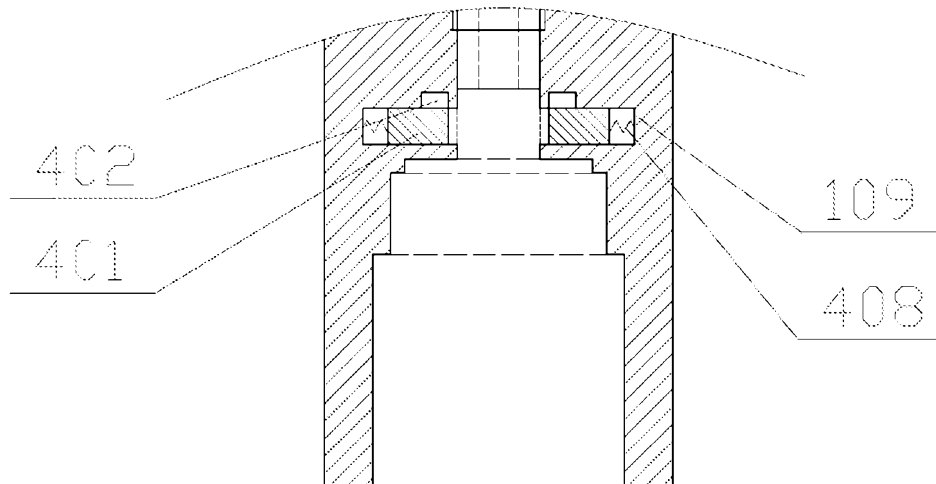


Fig. 11

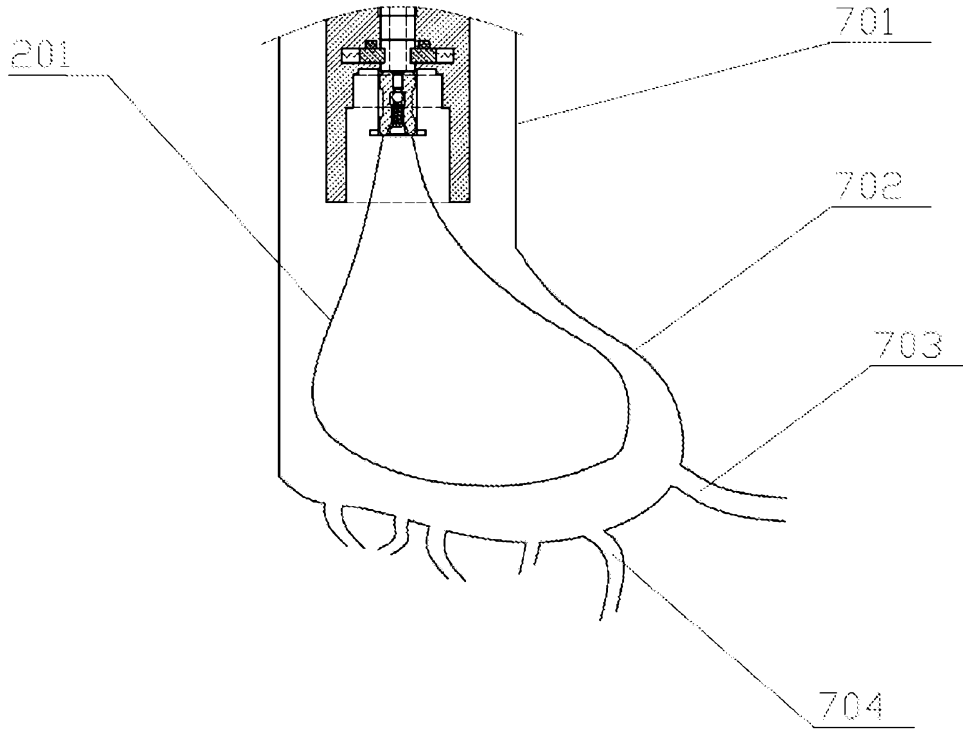


Fig. 12

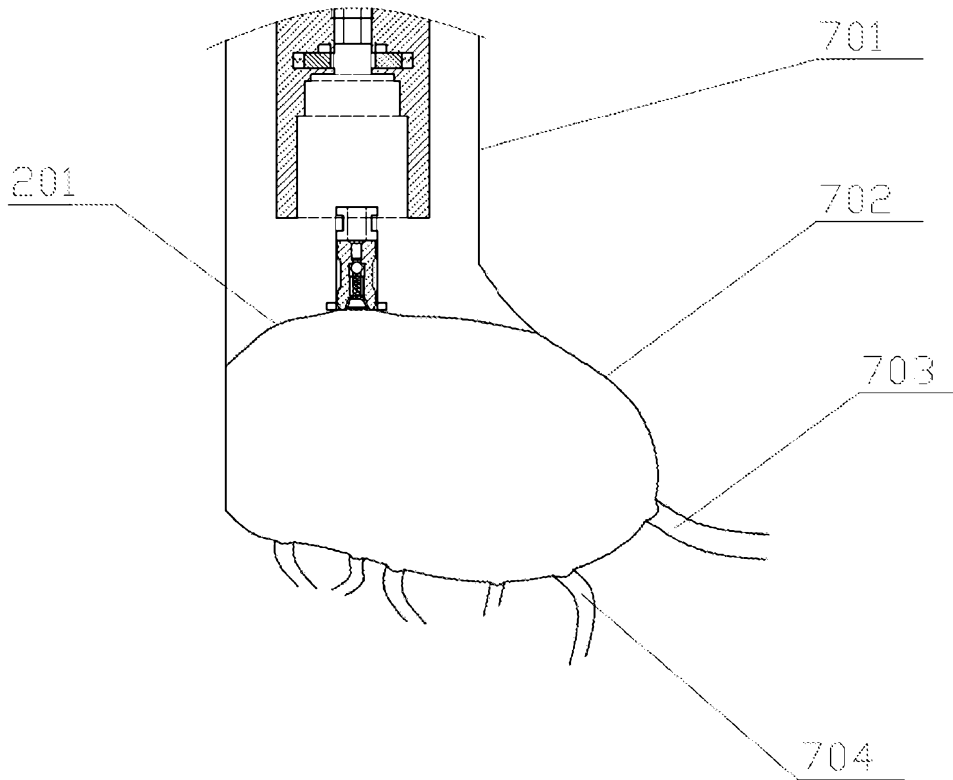


Fig. 13

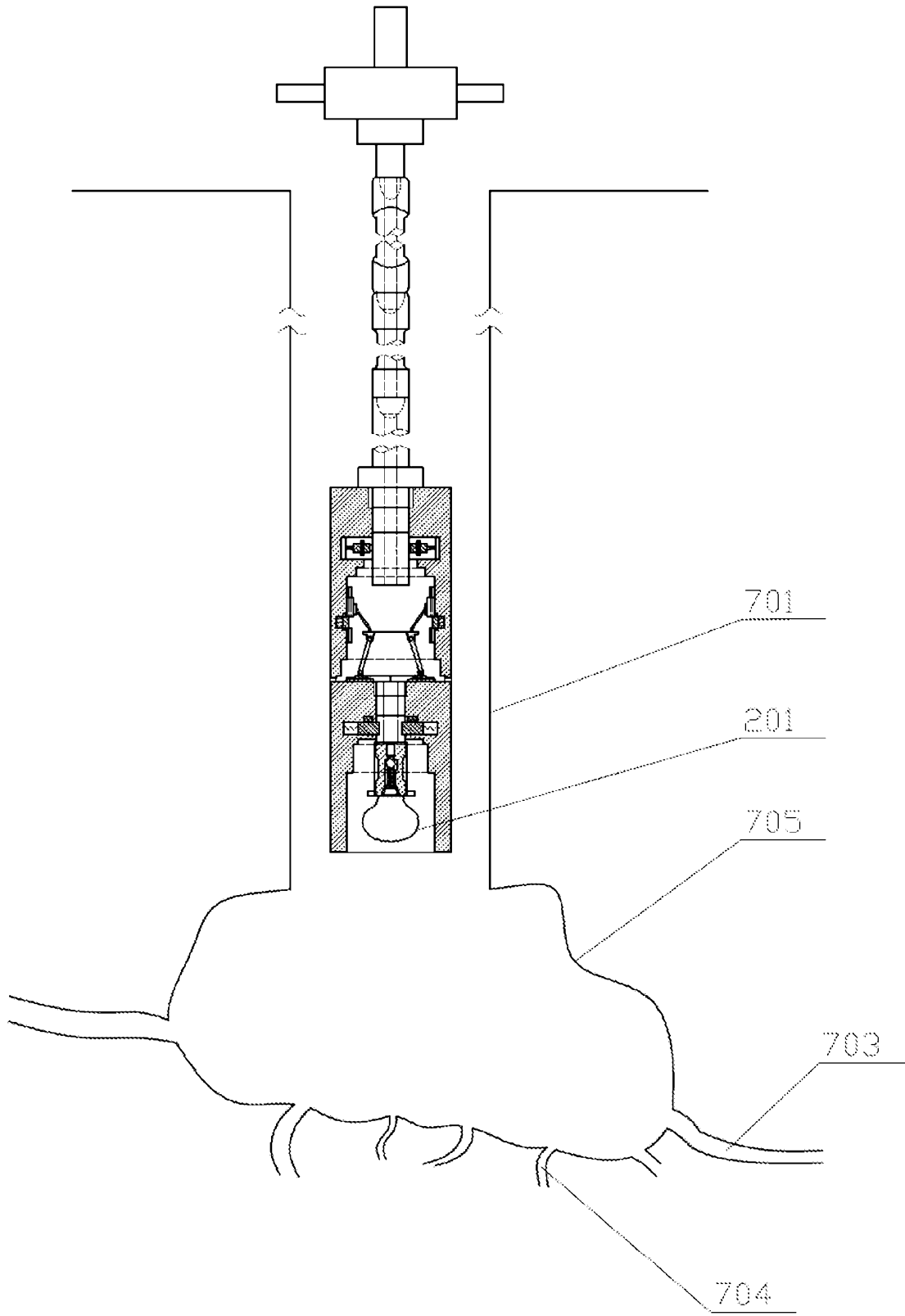


Fig. 14

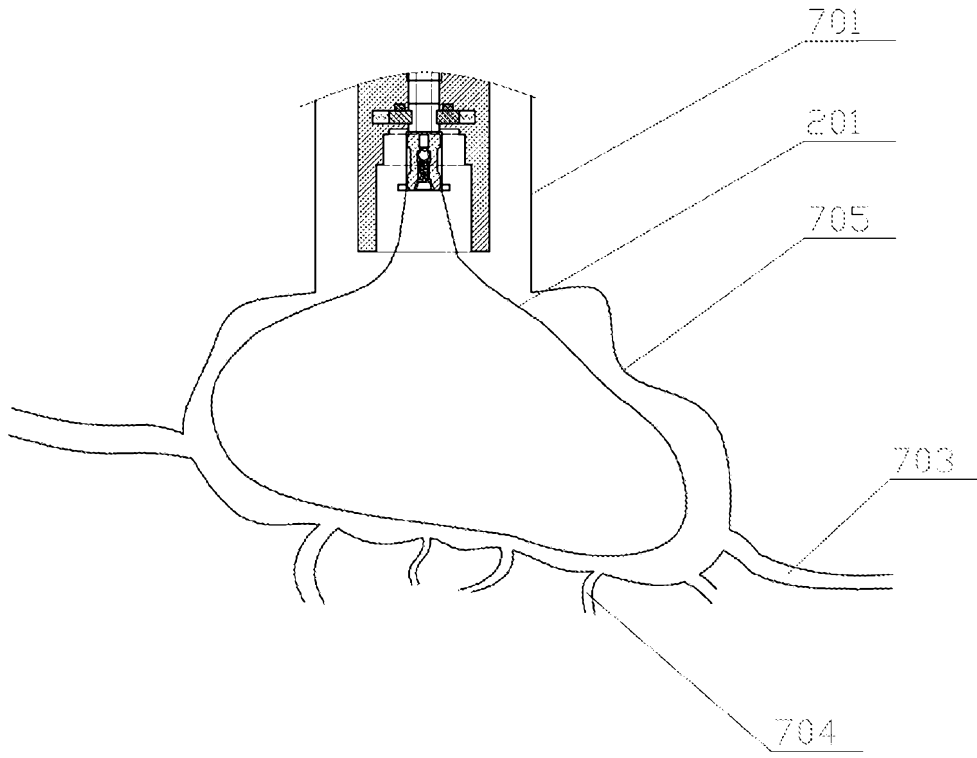


Fig. 15

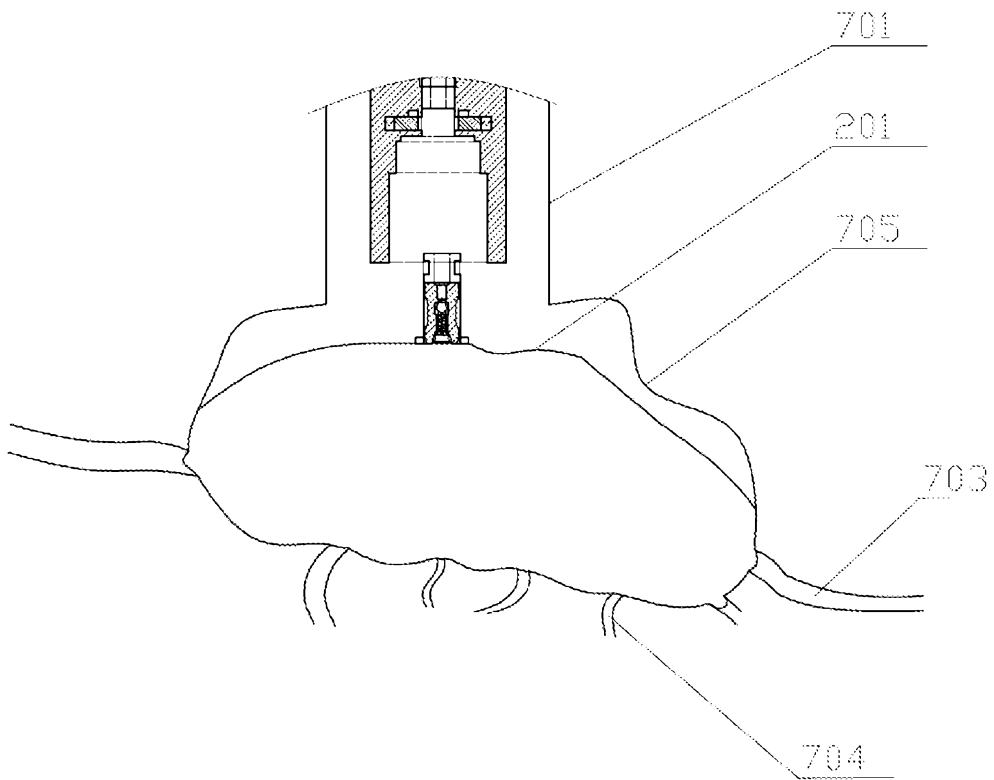


Fig. 16

# **ENVIRONMENTALLY FRIENDLY CAPSULAR BAG-TYPE DOWNHOLE KARST CAVE BLOCKING DEVICE, AND BLOCKING METHOD THEREFOR**

## **Technical Field:**

The field of the invention is about the petroleum drilling, which involves an environment friendly bag-type underground karst cave plugging device and methods.

## **Background:**

When drilling bit is used under the ground, extreme geological conditions, such as the karst cave, cracks, the crisp underground rock and porous soil are often encountered. It may lead to the loss of the drilling fluid and cement, and thus produce great waste and environment contamination. A considerable number of manpower, material resources and financial capacity may be lost, and even a series of serious accidents such as the sticking, sloughing and blowout may be caused. Therefore, it is essential to enhance the safety of the blocking process in the process of drilling works.

For leak stoppage, the frequently-used techniques includes perfecting the material for plugging, throwing the cement ball, detritus or grouan into the pit bottom followed by adding the plugging agent. The caves with fine geological conditions can be solved by these ways. However, due to the high cost and low efficiency, it is hard to block the large and alveolate caves in the above way. It requires rapid hardening and environmental friendliness. The plugging materials will leak seriously in alveolate caves and flow into the underground cracks and then pollute the cenotes. Therefore, the traditional plugging way is only suitable for the cave with the relatively small volume and good situation.

## **Summary:**

To solve the problem in plugging large and alveolate karst caves, this invention provides an environment friendly bag-type underground karst cave plugging device and methods. The cement is injected from the wellhead into the bag in the bottom of the caves until the cave is filled with the bag. And then the bag filled with the cement will be threw into the cave. The next drilling work can be normally continued when the cement is efficiently solidified. The embodiments of the invention to be described can not only plug the cave quickly but also solve the problems such as the leakage of the drilling fluid or cement. Thus, it can profoundly

increase the efficiency and reduce the cost of plugging.

To achieve the above purpose, this invention takes a series of mechanical transmissions. In the device, the connecting rod, hinge, spring, one-way valve, slide rail, ultrasonic sensor, ratchet, electromagnet and other mechanical parts combined transmission mode are used. The cement is injected into the bag until it has the same volume of the cave. And finally the cave can be plugged when the bag falls into the cave. In the above way, the environment-friendly plugging work can be successfully achieved. This way can reduce the requirement of the plugging material, and it can be applied in the large and alveolate caves.

#### **Brief Description of the Drawings:**

Fig. 1 The total structure diagram of an environment friendly bag-type underground karst cave plugging device.

Fig. 2 The structure diagram of the upper portion of the sleeve.

Fig. 3 The structure diagram of the bottom part of the sleeve.

Fig. 4 The partial structure diagram of the opening and closing device.

Fig. 5 The partial structure diagram of the ratchet device in the opening and closing device.

Fig. 6 The planform of the upper part of the opening and closing device.

Fig. 7 The planform of the bottom part of the opening and closing device.

Fig. 8 The structure diagram of the drilling tool and liquid injection system.

Fig. 9 The diagram of the unilateral cave.

Fig. 10 The working diagram of the opening and closing device.

Fig. 11 The working diagram of the lower part of the sleeve.

Fig. 12 The cement injection working diagram of the device in the unilateral cave.

Fig. 13 The throwing bag working diagram of the device in the unilateral cave.

Fig. 14 The diagram of the bilateral cave.

Fig. 15 The cement injection working diagram of the device in the bilateral cave.

Fig. 16 The throwing bag working diagram of the device in the bilateral cave.

The labels of all the mechanisms in the above figures are as follows:

1-sleeve, 101-drilling fluid holes, 102-longitudinal slide rails, 103-sensor installation slots, 104-clamping pin, 105-receiving tube 1, 106-installation slots for the radial slider 1, 107-racks, 108-receiving tube 2, 109-installation slots for the radial slider 3.

2-cement receiving device, 201-bag, 202-throat hoop, 203-receiving tube 4, 204-one-way valve, 205-receiving tube 3.

3-opening and closing device, 301-pawl, 302-rubber plug, 303-driven rocker, 304-ring, 305-longitudinal slider, 306 connecting plate, 307-connection column, 308-connection block,

309-hinge 1, 310-hinge 2, 311-hinge 3, 312-radial slider 2.

4-sensing control system, 401-radial slider 3, 402-electromagnet 2, 403-radial slider 1, 404-electromagnet 1, 405-ultrasonic sensor, 406-control system, 407-spring 1, 408-spring 2.

5-drilling tool, 501-drill collar, 502- drill pipe, 503- the square drill pipe.

6-liquid injection system, 601-injection hole 1, 602-injection hole 2, 603-injection hole 3, 604-junction, 605-connector.

701-wellbore, 702-unilateral cave, 703-cenotes, 704-bottom cracks, 705- bilateral cave.

### **Detailed Description:**

Referring to Fig. 1, 2, 3, 4, 5 and 6, an embodiment of an environment friendly bag-type underground karst cave plugging device according to the present disclosure is shown. The total device includes a sleeve (1), cement receiving device (2), opening and closing device (3), sensing control system (4), drilling tool (5) and liquid injection system (6). The first and second step type cavity are in the middle and bottom of the sleeve, respectively. The opening and closing device (3) and cement receiving device (2) are installed in the first and second step type cavity, respectively. Two drilling fluid holes (101) are symmetrically set on the side wall of the first step type cavity in the sleeve (1). Two longitudinal slide rails (102) and installation slots (106) are symmetrically set on the side wall of the first step type cavity. The installation slots (106) are located on the middle of the longitudinal slide rails (102). Four uniformly circumferential distributed racks (107) are fixed on the bottom of the first step type cavity. Two sensor installation slots (103) are symmetrically set on the top of side wall of the first step type cavity. Two installation slots (109) for the radial slider 3 are set on the side wall of the first and second step type cavity, respectively. A clamping pin (104) is set in the top of the sleeve (1). The receiving tube 1 (105) is set between the clamping pin (104) and the first step type cavity, and the receiving tube 2 (108) is installed between the first and second step type cavity.

Referring to Fig. 1, 2, 3, 4, 5, 6 and 7, the opening and closing device (3) includes the pawl (301), rubber plug (302), the driven rocker (303), ring (304), longitudinal slider (305), connecting plate (306), connection column (307), connection block (308), hinges 1 (309), hinge 2 (310), hinge 3 (311) and radial slider 2 (312). The two longitudinal sliders (305) are set on the two longitudinal slide rails (102), respectively. The connecting plate (306) is soldered onto the longitudinal slider (305). One of the ends of the connection column (307) is soldered onto the connecting plate (306), the other one is soldered onto the ring (304). One end of the two driven rockers (303) is symmetrically hinged on the ring (304) by the hinge 1 (309), and the other end is hinged on the radial slider 2 (312) by the hinge 2 (310). The bottom of the radial slider 2 (312) is in contacted with the one of the first step type cavity, and it can cover up the

tunnel of the receiving tube 2 (108). The rubber plug (302), which is pointed to the drilling fluid hole (101), is installed on the side of the radial slider 2 (312). The pawl (301) is hinged on the radial slider 2 (312) by the hinge 3 (311), and the ratchet mechanism is formed by the pawl (301) and the racks (107).

Referring to Fig. 1 and 3, the cement receiving device (2), which links the receiving tube 2 (108) by the receiving tube 3 (205), is installed in the second step type cavity. The drilling tool (5) is linked with the sleeve (1) with the clamping pin (104). The liquid injection system (6) is installed above the drilling tool (5) by the thread.

Referring to Fig. 1, 2, 3 and 4, the sensing control system (4) includes radial slider 3 (401), electromagnet 2 (402), radial slider 1 (403), electromagnet 1 (404), ultrasonic sensor (405), control system (406), spring 1 (407) and spring 2 (408). The two radial sliders 3 (401), which props the receiving tube 3 (205), are respectively installed in the installation slots (109). The two electromagnets 2 (402) are installed on the outside of the installation slots (109). The two radial sliders 1 (403) is installed in the installation slots (106). Two electromagnets 1 (404) are set on the outside of the two sensor installation slots (103), respectively. The spring 1 (407) is set between the installation slots (106) and the radial slider 1 (403), and the spring 2 (408) is installed between the installation slots (109) and radial sliders 3 (401).

In the depicted embodiment the ultrasonic sensor (405) is used to measure the volume of caves, receive the signal of blocking the drilling fluid holes (101), open the receiving tube 2 (108) and test whether the drilling fluid holes (101) and receiving tube 2 (108) are closed and open, respectively. The control system (406) controls the electromagnet 1 (404) to start-up the opening and closing device (3) according to the ultrasonic sensor (405). When all the measured cement is injected into the bag (201), the control system (406) can receive the signal from the ultrasonic sensor (405) and control the working status of the electromagnet 2 (402) to make the cement receiving device (2) and sleeve (1) separate.

Referring to Fig. 1 and 3, the cement receiving device (2) includes the bag (201), throat hoop (202), receiving tube 4 (203), one-way valve (204) and receiving tube 3 (205). The receiving tube 3 (205) is linked with the receiving tube 2 (108). The receiving tube 4 (203) is linked with the receiving tube 3 (205) by the thread. The one-way valve (204) is connected with the bag (201). The throat hoop (202) is fixed on the receiving tube 4 (203). The bag (201) is fixed on the receiving tube 4 (203) by the throat hoop (202).

Referring to Fig. 1 and 8, the drilling tool (5) includes drill collar (501), drill pipe (502) and the square drill pipe (503). The drill collar (501) is linked with the clamping pin (104). The number of drill pipe (502) is determined according to the fact. The drill pipe (502) is linked

with drill collar (501) by the thread. The square drill pipe (503) is linked with liquid injection system (6) by the thread.

Referring to Fig. 1 and 8, liquid injection system (6) includes the injection hole 1 (601), injection hole 2 (602), injection hole 3 (603), junction (604) and connector (605). The junction (604) is soldered onto the upper of the connector (605). The injection hole 2 (602) is soldered onto the upper of the junction (604). The injection hole 1 (601) and injection hole 3 (603) are soldered onto the two sides of the junction (604). The connector (605) is linked with the drilling tool (5) by the thread.

The above specification, examples and data provides a complete description of the invention. Since many embodiments of the invention can be made without departing from the script and scope of the invention, the invention resides in the claims hereinafter appended.

The specific plugging method of an environment friendly bag-type underground karst cave plugging device includes the following steps;

The step S1, when the underground karst cave is found in the drilling process, the drilling tool (5) needs to be took out from the pit. After removing the drill from the drilling tool (5), the sleeve (1) is installed on the lower part of the drilling tool (5).

The step S2, when the drilling tool (5) transports to the specified location, the ultrasonic sensor (405) in the sleeve (1) measures the volume of the cave and send the signal to the ground system. The corresponding amount of cement can be selected based on the measured results.

The step S3, the drilling fluid is injected from the injection hole 1 (601) into the drill pipe. The radial slider 2 (312) covers up the receiving tube 2 (108), so the drilling fluid can flow out from the injection hole 1 (601). This can clean the wellbore (701) and provide a certain pressure to prevent it from destabilizing.

The step S4, after cleaning the cave, a wooden pellet is threw in from the injection hole 2 (602). The wooden pellet falls into the tube from the drilling tool (5) until reach the interior of the sleeve (1).

The step S5, when the ultrasonic sensor (405) receives the trigger signal from the wooden pellet, the control system (406) makes the electromagnet 1 (404) stop working and the electromagnet 1 (404) loses the magnetic. Then the radial slider 1 (403) absorbed by the electromagnet 1 (404), receives the force of the spring 1 (407) and moves from the center to the wall of the sleeve (1). The longitudinal slider (305) sustained by the radial slider 1 (403) declines along the longitudinal slide rails (102) owing to the gravity. In the meanwhile, the connecting plate (306), connection column (307), connection block (308), which are soldered together, also decline. Thanks to the effect of the hinge 1 (309) and hinge 2 (310), the driven

rocker (303) rotates, and it makes the radial slider 2 (312) move from the center to the wall of the sleeve (1) until the rubber plug (302) block the drilling fluid holes (101). A ratchet device consists of the pawl (301) and the racks (107) installed on the two sides of the radial slider 2 (312). Thus, the radial slider 2 (312) can only move from the center to the wall of the sleeve (1) rather than moving in the reverse direction.

The step S6, when the rubber plug (302) blocks the drilling fluid holes (101), the ultrasonic sensor (405) receives the trigger signal. The cement is injected from the injection hole 3 (603) and then flows from the drilling tool (5) into the sleeve (1). Due to the lack of the blocking of the radial slider 2 (312), the cement flows through the receiving tube 2 (108), receiving tube 3 (205) and receiving tube 4 (203) from the tube of the receiving tube 2 (108) into the bag (201).

The step S7, when the bag (201) is filled with the cement, it expands along the wall of the cave quickly.

The step S8, when all the cement is injected into the bag (201), the bag (201) expands until its volume is as big as the one of the cave. Then the control system (406) makes the electromagnet 2 (402) stop working. The radial slider 3 (401) will suffer the tension from the spring 2 (408) when the electromagnet 2 loses the magnetic. And then it will induce that the radial slider 3 (401) moves from the center to the wall of the sleeve (1). The receiving tube 3 (205), which was propped up by the radial slider 3 (401) will decline according to the gravity. It makes the receiving tube 3 (205), receiving tube 4 (203), one-way valve (204) and the bag (201) separate with the sleeve (1) and then fall into the cave. Due to the effect of the one-way valve (204), the cement which flew into the bag (201) can not outflow. If the volume of the cave is too large, the system will pull out the drill pipe (502) and the sleeve (1), and a new sleeve (1) will be installed on the device. When the above action is repeated, the cenotes (703) and bottom cracks (704) can be blocked thoroughly.

The step S9, the drilling fluid is injected from the injection hole 1 (601) into the drilling tool (5) and sleeve (1), and then flows out from the receiving tube 2 (108). The residual cement in the sleeve (1) and drilling tool (5) can be cleaned up.

The step S10, after the above process, the device can be removed from the cave. When the cement in the bag (201) binds together, the cave is successfully blocked. And the normal drilling work can be continued safely.

The cave in the above words is unilateral cave (702) or bilateral cave (705).

The mechanism of an environment friendly bag-type underground karst cave plugging device and methods are as follows. The cement is injected into the bag until it has the same volume of the cave. Finally, the cave will be plugged when the bag falls into the cave. When

the cement in the bag binds together, the next drilling process can be continued again. In this way, the plugging material can be effectively utilized. This way can not only plug the cave quickly but also solve problems such as the leakage of the drilling fluid and cement in the large and alveolate caves. In summary, this device possesses the properties of the low cost, easy maintenance and low pollution. Furthermore, the combination of the opening and closing device and sensor control-system make the invention have advantages of simple structure, easy to operate and high efficiency. These advantages can make it replace the traditional plugging technologies.

### **Mode of Carrying out the Invention:**

The following is further illustrated with the accompanying drawings and specific embodiments, but the protection scope of this invention is not limited to this.

The utility model relates to an embodiment of an environment friendly bag-type underground karst cave plugging device. The total device includes a sleeve (1), cement receiving device (2), opening and closing device (3), sensing control system (4), drilling tool (5) and liquid injection system (6).

As shown in Fig. 1, 2, 3 and 4, the first and second step type cavity are in the middle and bottom of the sleeve, respectively. The opening and closing device (3) and cement receiving device are installed in the first and second step type cavity, respectively. Two drilling fluid holes (101) are symmetrically set on the side wall of the first step type cavity in the sleeve (1). Two longitudinal slide rails (102) and installation slots (106) are symmetrically set on the side wall of the first step type cavity. The installation slots (106) are located on the middle of the longitudinal slide rails (102). Four uniformly circumferential distributed racks (107) are fixed on the bottom of the first step type cavity. Two sensor installation slots (103) are symmetrically set on the top of side wall of the first step type cavity. Two installation slots (109) for the radial slider 3 are set on the side wall of the first and second step type cavity, respectively. A clamping pin (104) is set in the top of the sleeve (1). The receiving tube 1 (105) is set between the clamping pin (104) and the first step type cavity, and the receiving tube 2 (108) is installed between the first and second step type cavity.

The opening and closing device (3) includes the pawl (301), rubber plug (302), the driven rocker (303), ring (304), longitudinal slider (305), connecting plate (306), connection column (307), connection block (308), hinges 1 (309), hinge 2 (310), hinge 3 (311) and radial slider 2 (312). The two longitudinal sliders (305) are set on the two longitudinal slide rails (102), respectively. The connecting plate (306) is soldered onto the longitudinal slider (305). One of

the ends of the connection column (307) is soldered onto the connecting plate (306), the other one is soldered onto the ring (304). The above devices are depicted in Fig. 6. One end of the two driven rockers (303) is symmetrically hinged on the ring (304) by the hinge 1 (309), and the other end is hinged on the radial slider 2 (312) by the hinge 2 (310). The bottom of the radial slider 2 (312) is in contacted with the one of the first step type cavity, and it can cover up the tunnel of the receiving tube 2 (108). The rubber plug (302), which is pointed to the drilling fluid hole (101), is installed on the side of the radial slider 2 (312). The pawl (301) is hinged on the radial slider 2 (312) by the hinge 3 (311), and the ratchet mechanism is formed by the pawl (301) and the racks (107), as shown in Fig. 5 and 7.

The cement receiving device (2), which linked the receiving tube 2 (108) by the receiving tube 3 (205), is installed in the second step type cavity. The drilling tool (5) is linked with the sleeve (1) with the clamping pin (104). The liquid injection system (6) is installed above the drilling tool (5) by the thread. The cement receiving device (2) includes the bag (201), throat hoop (202), receiving tube 4 (203), one-way valve (204) and receiving tube 3 (205). The receiving tube 3 (205) is linked with the receiving tube 2 (108). The receiving tube 4 (203) links with the receiving tube 3 (205) by the thread. The one-way valve (204) is connected with the bag (201). The throat hoop (202) is fixed on the receiving tube 4 (203). The bag (201) is fixed on the receiving tube 4 (203) by the throat hoop (202).

The sensing control system (4) includes radial slider 3 (401), electromagnet 2 (402), radial slider 1 (403), electromagnet 1 (404), ultrasonic sensor (405), control system (406), spring 1 (407) and spring 2 (408). The two radial sliders 3 (401), which props the receiving tube 3 (205), are installed in the installation slots (109), respectively. The two electromagnets 2 (402) are installed on the outside of the installation slots (109). The two radial sliders 1 (403) are installed in the installation slots (106). Two electromagnets 1 (404) are set on the outside of the two sensor installation slots (103), respectively. The spring 1 (407) is set between the installation slots (106) and the radial slider 1 (403), and the spring 2 (408) is installed between the installation slots (109) and radial sliders 3 (401).

In the depicted embodiment the ultrasonic sensor (405) is used to measure the volume of caves, receive the signal of blocking the drilling fluid holes (101), open the receiving tube 2 (108) and test whether the drilling fluid holes (101) and receiving tube 2 (108) are closed and open, respectively. The control system (406) control the electromagnet 1 (404) to start-up the opening and closing device (3) according to the ultrasonic sensor (405) and electromagnet 1 (404). When the drilling fluid holes (101) and receiving tube 2 (108) are closed and open, respectively, the control system (406) can receive the signal from the ultrasonic sensor (405)

and control the working status of the electromagnet 2 (402) to make the cement receiving device (2) and sleeve (1) separate.

As shown in Fig. 8, the drilling tool (5) includes drill collar (501), drill pipe (502) and the square drill pipe (503). The drill collar (501) is linked with the clamping pin (104). The number of drill pipe (502) is determined according to the fact. The drill pipe (502) is linked with drill collar (501) by the thread. The square drill pipe (503) is linked with liquid injection system (6) by the thread.

As shown in Fig. 8, the liquid injection system (6) includes the injection hole 1 (601), injection hole 2 (602), injection hole 3 (603), junction (604) and connector (605). The junction (604) is soldered onto the upper of the connector (605). The injection hole 1 (601) and injection hole 3 (603) are soldered onto the two sides of the junction (604). The connector (605) is linked with the drilling tool (5) by the thread.

### **The embodiment 1:**

An environment friendly bag-type underground karst cave plugging device and methods are described in detail in conjunction with the accompanying drawings, which includes the following steps:

The step S1, when the unilateral cave (702) is found in the drilling process, the drilling tool (5) should be took out from the pit. After taking down the drill from the drilling tool (5), the sleeve (1) is installed on the lower part of the drilling tool (5).

The step S2, as shown in Fig. 9, when the drilling tool (5) transported to the specified location of the unilateral cave (702), the ultrasonic sensor (405) in the sleeve (1) measures the volume of the unilateral cave (702) and sends the signal to the ground system. The corresponding amount of cement can be selected according to the measured results.

The step S3, the drilling fluid is injected from the injection hole 1 (601) into the drill pipe. The radial slider 2 (312) covers up the receiving tube 2 (108), thus the drilling fluid can flow out from the injection hole 1 (601), which can clean the wellbore (701) and provide a certain pressure to prevent it from destabilizing.

The step S4, after cleaning the cave, a wooden pellet is threw in from the injection hole 2 (602). The wooden pellet falls into the tube from the drilling tool (5) until reach the interior of the sleeve (1).

The step S5, when the ultrasonic sensor (405) receives the trigger signal produced from the wooden pellet, the control system (406) makes the electromagnet 1 (404) stop working and the electromagnet 1 (404) loses the magnetic. Then the radial slider 1 (403), which was

absorbed by the electromagnet 1 (404), receives the force of the spring 1 (407) and moves from the center to the wall of the sleeve (1). As shown in Fig. 10, the longitudinal slider (305) sustained by the radial slider 1 (403) declines along the longitudinal slide rails (102) owing to the gravity. In the meanwhile, the connecting plate (306), connection column (307), connection block (308), which was soldered together also declines. Thanks to the effect of the hinge 1 (309) and hinge 2 (310), the driven rocker (303) rotates, and it makes the radial slider 2 (312) move from the center to the wall of the sleeve (1) until the rubber plug (302) blocks the drilling fluid holes (101). A ratchet device consists of the pawl (301) and the racks (107) installed on the two sides of the radial slider 2 (312), thus, the radial slider 2 (312) can only move from the center to the wall of the sleeve (1) rather than moving in the reverse direction. The diagram of the ratchet device is showed in Fig. 5.

The step S6, when the rubber plug (302) blocks the drilling fluid holes (101), the ultrasonic sensor (405) receives the trigger signal. The cement is injected from the injection hole 3 (603) and then flows from the drilling tool (5) into the sleeve (1). Due to the lack of the blocking of the radial slider 2 (312), the cement flows through the receiving tube 2 (108), receiving tube 3 (205) and receiving tube 4 (203) from the tube of the receiving tube 2 (108) to the bag (201).

The step S7, when the bag (201) is filled with the cement, it expands along the wall of the cave quickly. The working condition diagram is shown in Fig. 12.

The step S8, when all the cement is injected into the bag (201), the bag (201) expands until its volume is as big as the one of the unilateral cave (702). Then the control system (406) makes the electromagnet 2 (402) stop working. The radial slider 3 (401) suffers the tension from the spring 2 (408) when the electromagnet 2 loses the magnetic. And then it induces that the radial slider 3 (401) moves from the center to the wall of the sleeve (1). The receiving tube 3 (205), which was propped up by the radial slider 3 (401) declines according to the gravity. It makes the receiving tube 3 (205), receiving tube 4 (203), one-way valve (204) and the bag (201) separate with the sleeve (1) and they falls into the unilateral cave (702). Due to the effect of the one-way valve (204), the cement which was flew into the bag (201) can not flow away. If the volume of the unilateral cave (702) is too large, the system will pull out the drill pipe (502) and the sleeve (1), and a new sleeve (1) will be installed on the device. When the above action is repeated again, the cenotes (703) and bottom cracks (704) in the unilateral cave (702) can be blocked thoroughly. The working condition diagram is shown in Fig. 11, 12 and 13.

The step S9, the drilling fluid is injected from the injection hole 1 (601) into the drilling tool (5) and sleeve (1), and then it flows out from the receiving tube 2 (108). The residual cement in the sleeve (1) and drilling tool (5) can be cleaned up.

The step S10, after the above process, the device will be took out from the cave. When the cement in the bag (201) binds together, the unilateral cave (702) is successfully blocked. And the normal drilling work can be continued safely.

### **The embodiment 2:**

An environment friendly bag-type underground karst cave plugging device and methods are described in detail in conjunction with the accompanying drawings, which includes the following steps:

The step S1, when the bilateral cave (705) is found in the drilling process, the drilling tool (5) should be took out from the pit. After taking down the drill from the drilling tool (5), the sleeve (1) is installed on the lower part of the drilling tool (5).

The step S2, as shown in Fig. 14, when the drilling tool (5) transported to the specified location of the bilateral cave (705), the ultrasonic sensor (405) in the sleeve (1) measures the volume of the bilateral cave (705) and send the signal to the ground system. The corresponding amount of cement can be selected according to the measured results.

The step S3, the drilling fluid is injected from the injection hole 1 (601) into the drill pipe. The radial slider 2 (312) covers up the receiving tube 2 (108), thus the drilling fluid can flow out from the injection hole 1 (601), which can clean the wellbore (701) and provide it with a certain pressure to prevent it from destabilizing.

The step S4, after cleaning the cave, a wooden pellet is threw in from the injection hole 2 (602). The wooden pellet falls into the tube from the drilling tool (5) until it reached the interior of the sleeve (1).

The step S5, when the ultrasonic sensor (405) receives the trigger signal produced from the wooden pellet, the control system (406) makes the electromagnet 1 (404) stop working and the electromagnet 1 (404) loses the magnetic. Then the radial slider 1 (403), which was absorbed by the electromagnet 1 (404), receives the force of the spring 1 (407) and moves from the center to the wall of the sleeve (1). As shown in Fig. 10, the longitudinal slider (305) sustained by the radial slider 1 (403) declines along the longitudinal slide rails (102) owing to the gravity. In the meanwhile, the connecting plate (306), connection column (307), connection block (308), which is soldered together also declines. Thanks to the effect of the hinge 1 (309) and hinge 2 (310), the driven rocker (303) rotates, and it makes the radial slider 2 (312) move from the center to the wall of the sleeve (1) until the rubber plug (302) blocks the drilling fluid holes (101). A ratchet device consists of the pawl (301) and the racks (107) installed on the two sides of the radial slider 2 (312), thus, the radial slider 2 (312) can only move from the center to the wall of the sleeve (1) rather than moving in the reverse direction. The diagram of the ratchet device is showed in Fig. 5.

The step S6, when the rubber plug (302) block the drilling fluid holes (101), the ultrasonic sensor (405) receives the trigger signal. The cement is injected from the injection hole 3 (603)

and then flow from the drilling tool (5) into the sleeve (1). Due to the lack of the blocking of the radial slider 2 (312), the cement flows through the receiving tube 2 (108), receiving tube 3 (205) and receiving tube 4 (203) from the tube of the receiving tube 2 (108) to the bag (201).

The step S7, when the the bag (201) is filled with the cement, it expands along the wall of the cave quickly. The working condition diagram is depicted in Fig. 15.

The step S8, when all the cement is injected into the bag (201), the bag (201) expands until its volume is as big as the one of the cave. Then the control system (406) makes the electromagnet 2 (402) stop working. The radial slider 3 (401) suffers the tension from the spring 2 (408) when the electromagnet 2 loses the magnetic. And then it induces that the radial slider 3 (401) moves from the center to the wall of the sleeve (1). The receiving tube 3 (205), which was propped up by the radial slider 3 (401) will decline according to the gravity. It makes the receiving tube 3 (205), receiving tube 4 (203), one-way valve (204) and the bag (201) separate with the sleeve (1) and they will fall into the cave. Due to the effect of the one-way valve (204), the cement which was flew into the bag (201) can not flow away. If the volume of the cave is too large, the system will pull out the drill pipe (502) and the sleeve (1), and a new sleeve (1) will be installed on the device. When the above action is repeated again, the cenotes (703) and bottom cracks (704) can be blocked thoroughly. The working condition diagram is shown in Fig. 11, 15 and 16.

The step S9, the drilling fluid is injected from the injection hole 1 (601) into the drilling tool (5) and sleeve (1), and then it flows out from the receiving tube 2 (108). The residual cement in the sleeve (1) and drilling tool (5) can be cleaned up.

The step S10, after the above process, the device is took out from the cave. When the cement in the bag (201) binds together, the bilateral cave (705) is successfully blocked. And the normal drilling work can be continued safely.

The described embodiment is a preferred embodiment of the invention, but the invention is not limited to the above implementation. Without deviating from the substance of the invention, any obvious improvement, replacement or variant of the technical personnel of the field belong to the scope of the protection of the invention.

## Claims

1. An environment friendly bag-type underground karst cave plugging device includes the sleeve (1), cement receiving device (2), opening and closing device (3), sensing control system (4), drilling tool (5) and liquid injection system (6);

the first and second step type cavity are in the middle and bottom of the sleeve respectively, the opening and closing device (3) and cement receiving device (2) are installed in the first and second step type cavity respectively; two drilling fluid holes (101) are symmetrically set on the side wall of the first step type cavity in the sleeve (1), two longitudinal slide rails (102) and installation slots (106) are symmetrically set on the side wall of the first step type cavity, the installation slots (106) are located on the middle of the longitudinal slide rails (102); four uniformly circumferential distributed racks (107) are fixed on the bottom of the first step type cavity, two sensor installation slots (103) are symmetrically set on the top of side wall of the first step type cavity, two installation slots (109) for the radial slider 3 are symmetrically set on the side wall of the first and second step type cavity, respectively; a clamping pin (104) is set in the top of the sleeve (1), the receiving tube 1 (105) is set between the clamping pin (104) and the first step type cavity, and the receiving tube 2 (108) is installed between the first and second step type cavity;

the opening and closing device (3) includes the pawl (301), rubber plug (302), the driven rocker (303), ring (304), longitudinal slider (305), connecting plate (306), connection column (307), connection block (308), hinge 1 (309), hinge 2 (310), hinge 3 (311) and radial slider 2 (312); the two longitudinal sliders (305) are set on the two longitudinal slide rails (102), respectively, the connecting plate (306) is soldered onto the longitudinal slider (305), one of the ends of the connection column (307) is soldered onto the connecting plate (306) and the other end is soldered onto the ring (304), one end of the two driven rockers (303) is symmetrically hinged on the ring (304) by the hinge 1 (309), and the other end is hinged on the radial slider 2 (312) by the hinge 2 (310), the bottom of the radial slider 2 (312) is in contacted with the one of the first step type cavity, and it can cover up the tunnel of the receiving tube 2 (108), the rubber plug (302), which is pointed to the drilling fluid hole (101), is installed on the side of the radial slider 2 (312), the pawl (301) is hinged on the radial slider 2 (312) by the hinge 3 (311), and the ratchet mechanism is formed by the pawl (301) and the racks (107),

the cement receiving device (2), which links the receiving tube 2 (108) by the receiving tube 3 (205), is installed in the second step type cavity; the drilling tool (5) is linked with the sleeve (1) by the clamping pin (104); the liquid injection system (6) is installed above the

drilling tool (5) by the thread;

the sensing control system (4) includes the radial slider 3 (401), electromagnet 2 (402), radial slider 1 (403), electromagnet 1 (404), ultrasonic sensor (405), control system (406), spring 1 (407) and spring 2 (408); the two radial sliders 3 (401), which props the receiving tube 3 (205), are installed in the installation slots (109), respectively; the two electromagnets 2 (402) are installed on the outside of the installation slots (109), respectively, the two radial sliders 1 (403) is installed in the installation slots (106), respectively; two electromagnets 1 (404) are respectively set on the outside of the two sensor installation slots (103); the spring 1 (407) is set between the installation slots (106) and the radial slider 1 (403), and the spring 2 (408) is installed between the installation slots (109) and radial sliders 3 (401);

in the depicted embodiment the ultrasonic sensor (405) is used to measure the volume of caves, receive the signal of blocking the drilling fluid holes (101), opening the receiving tube 2 (108) and test whether the drilling fluid holes (101) and receiving tube 2 (108) are closed and open, respectively; the control system (406) controls the electromagnet 1 (404) to start-up the opening and closing device (3) according to the ultrasonic sensor (405); when all the measured cement is injected into the bag (201), the control system (406) can receive the signal from the ultrasonic sensor (405) and control the working status of the electromagnet 2 (402) to make the cement receiving device (2) and sleeve (1) separate.

2. The environment friendly bag-type underground karst cave plugging device of claim 1, wherein said the cement receiving device (2) includes the bag (201), throat hoop (202), receiving tube 4 (203), one-way valve (204) and receiving tube 3 (205); the receiving tube 3 (205) links the receiving tube 2 (108); the receiving tube 4 (203) links the receiving tube 3 (205) by the thread; the one-way valve (204), which is in the the receiving tube 4 (203), is connected with the bag (201); the throat hoop (202) is fixed on the receiving tube 4 (203); the bag (201) is fixed on the receiving tube 4 (203) by the throat hoop (202).

3. The environment friendly bag-type underground karst cave plugging device of claim 1, wherein said the drilling tool (5) includes drill collar (501), drill pipe (502) and the square drill pipe (503); the drill collar (501) is linked with the clamping pin (104); the number of drill pipe (502) depends on the volume of cave and it is linked with drill collar (501) by the thread; the square drill pipe (503) is linked with liquid injection system (6) by the thread.

4. The environment friendly bag-type underground karst cave plugging device of claim 1, wherein said the liquid injection system (6) includes the injection hole 1 (601), injection hole 2 (602), injection hole 3 (603), junction (604) and connector (605); the junction (604) is soldered onto the upper of the connector (605); the injection hole 2 (602) is soldered onto the

upper of the junction (604); the injection hole 1 (601) and injection hole 3 (603) are soldered onto the two sides of the junction (604), respectively; the connector (605) is linked with the drilling tool (5) by the thread.

5. An environment friendly bag-type underground karst cave plugging method of any one of claims 1-4, wherein which includes the following steps:

the step S1, when the underground karst cave is found in the drilling process, the drilling tool (5) needs to be took out from the pit, after removing the drill from the drilling tool (5), the sleeve (1) is installed on the lower part of the drilling tool (5);

the step S2, when the drilling tool (5) transports to the specified location, the ultrasonic sensor (405) in the sleeve (1) measures the volume of the cave and send the signal to the ground system, the corresponding amount of cement can be selected based on the measured results;

the step S3, the drilling fluid is injected from the injection hole 1 (601) into the drill pipe, the radial slider 2 (312) covers up the receiving tube 2 (108), so the drilling fluid can flow out from the injection hole 1 (601), this can clean the wellbore (701) and provide a certain pressure to prevent it from destabilizing;

the step S4, after cleaning the cave, a wooden pellet is threw in from the injection hole 2 (602), the wooden pellet falls into the tube from the drilling tool (5) until reach the interior of the sleeve (1);

the step S5, when the ultrasonic sensor (405) receives the trigger signal from the wooden pellet, the control system (406) makes the electromagnet 1 (404) stop working and the electromagnet 1 (404) loses the magnetic, then the radial slider 1 (403) absorbed by the electromagnet 1 (404), receives the force of the spring 1 (407) and moves from the center to the wall of the sleeve (1); the longitudinal slider (305) sustained by the radial slider 1 (403) declines along the longitudinal slide rails (102) owing to the gravity, in the meanwhile the connecting plate (306), connection column (307), connection block (308), which are soldered together, also decline; thanks to the effect of the hinge 1 (309) and hinge 2 (310), the driven rocker (303) rotates, and it makes the radial slider 2 (312) move from the center to the wall of the sleeve (1) until the rubber plug (302) block the drilling fluid holes (101); a ratchet device consists of the pawl (301) and the racks (107) installed on the two sides of the radial slider 2 (312), thus the radial slider 2 (312) can only move from the center to the wall of the sleeve (1) rather than moving in the reverse direction;

the step S6, when the rubber plug (302) blocks the drilling fluid holes (101), the ultrasonic sensor (405) receives the trigger signal, the cement is injected from the injection hole 3 (603) and then flows from the drilling tool (5) into the sleeve (1); due to the lack of the blocking of

the radial slider 2 (312), the cement flows through the receiving tube 2 (108), receiving tube 3 (205) and receiving tube 4 (203) from the tube of the receiving tube 2 (108) into the bag (201);

the step S7, when the bag (201) is filled with the cement, it expands along the wall of the cave quickly;

the step S8, when all the cement is injected into the bag (201), the bag (201) expands until its volume is as big as the one of the cave, then the control system (406) makes the electromagnet 2 (402) stop working, the radial slider 3 (401) will suffer the tension from the spring 2 (408) when the electromagnet 2 loses the magnetic, and then it will induce that the radial slider 3 (401) moves from the center to the wall of the sleeve (1), the receiving tube 3 (205), which was propped up by the radial slider 3 (401) will decline according to the gravity, it makes the receiving tube 3 (205), receiving tube 4 (203), one-way valve (204) and the bag (201) separate with the sleeve (1) and then fall into the cave; due to the effect of the one-way valve (204), the cement which flew into the bag (201) can not outflow; if the volume of the cave is too large, the system will pull out the drill pipe (502) and the sleeve (1), and a new sleeve (1) will be installed on the device, when the above action is repeated, the cenotes (703) and bottom cracks (704) can be blocked thoroughly;

the step S9, the drilling fluid is injected from the injection hole 1 (601) into the drilling tool (5) and sleeve (1), and then flows out from the receiving tube 2 (108), the residual cement in the sleeve (1) and drilling tool (5) can be cleaned up;

the step S10, after the above process, the device can be removed from the cave, when the cement in the bag (201) binds together, the cave is successfully blocked, and the normal drilling work can be continued safely.

6. The environment friendly bag-type underground karst cave plugging method of claim 5, wherein the cave is unilateral cave (702) or bilateral cave (705).

# INTERNATIONAL SEARCH REPORT

International application No.  
PCT/CN2017/084793

## A. CLASSIFICATION OF SUBJECT MATTER

E02D 19/12 (2006.01) i; E21B 33/13 (2006.01) i

According to International Patent Classification (IPC) or to both national classification and IPC

## B. FIELDS SEARCHED

Minimum documentation searched (classification system followed by classification symbols)

E02D, E21B

Documentation searched other than minimum documentation to the extent that such documents are included in the fields searched

Electronic data base consulted during the international search (name of data base and, where practicable, search terms used)

CNKI, CNABS, CNTXT: 气囊, 气袋, 囊袋, 封堵, 堵漏, 溶洞, 洞穴, 传感器, 磁;

VEN: gas bag, air bag, air float, gas cell, air cell, seal, plugging, leaking stoppage, cave, cavity, sensor, magnet

## C. DOCUMENTS CONSIDERED TO BE RELEVANT

Category*	Citation of document, with indication, where appropriate, of the relevant passages	Relevant to claim No.
A	CN 105421475 A (CHINA ACADEMY OF BUILDING RESEARCH et al.), 23 March 2016 (23.03.2016) description, particular embodiments, and figures 1-14	1-6
A	CN 105298518 A (SHANDONG UNIVERSITY), 03 February 2016 (03.02.2016), entire document	1-6
A	CN 105821894 A (SINOHYDRO FOUNDATION ENGINEERING CO., LTD.), 03 August 2016 (03.08.2016), entire document	1-6
A	CN 106320728 A (ZHONGTIAN CONSTRUCTION GROUP CO., LTD.), 11 January 2017 (11.01.2017), entire document	1-6
A	CN 205776263 U (POWERCHINA GUIYANG ENGINEERING CORPORATION LIMITED), 07 December 2016 (07.12.2016), entire document	1-6
A	CN 202970767 U (WANG, Aiguo), 05 June 2013 (05.06.2013), entire document	1-6
A	DD 262887 A1 (KOMB GASANLAGEN MITTENWALDE VE), 14 December 1988 (14.12.1988), entire document	1-6

Further documents are listed in the continuation of Box C.

See patent family annex.

<p>* Special categories of cited documents:</p> <p>“A” document defining the general state of the art which is not considered to be of particular relevance</p> <p>“E” earlier application or patent but published on or after the international filing date</p> <p>“L” document which may throw doubts on priority claim(s) or which is cited to establish the publication date of another citation or other special reason (as specified)</p> <p>“O” document referring to an oral disclosure, use, exhibition or other means</p> <p>“P” document published prior to the international filing date but later than the priority date claimed</p>	<p>“T” later document published after the international filing date or priority date and not in conflict with the application but cited to understand the principle or theory underlying the invention</p> <p>“X” document of particular relevance; the claimed invention cannot be considered novel or cannot be considered to involve an inventive step when the document is taken alone</p> <p>“Y” document of particular relevance; the claimed invention cannot be considered to involve an inventive step when the document is combined with one or more other such documents, such combination being obvious to a person skilled in the art</p> <p>“&amp;” document member of the same patent family</p>
---	---

Date of the actual completion of the international search 16 November 2017	Date of mailing of the international search report 18 January 2018
---	---

<p>Name and mailing address of the ISA State Intellectual Property Office of the P. R. China No. 6, Xitucheng Road, Jimenqiao Haidian District, Beijing 100088, China Facsimile No. (86-10) 62019451</p>	<p>Authorized officer  CHEN, Gang  Telephone No. (86-10) 62085154</p>
--	---

**INTERNATIONAL SEARCH REPORT**  
Information on patent family members

International application No.  
PCT/CN2017/084793

Patent Documents referred in the Report	Publication Date	Patent Family	Publication Date
CN 105421475 A	23 March 2016	None	
CN 105298518 A	03 February 2016	None	
CN 105821894 A	03 August 2016	None	
CN 106320728 A	11 January 2017	None	
CN 205776263 U	07 December 2016	None	
CN 202970767 U	05 June 2013	None	
DD 262887 A1	14 December 1988	None	