

(19) World Intellectual Property
Organization
International Bureau



(43) International Publication Date
16 December 2004 (16.12.2004)

PCT

(10) International Publication Number
WO 2004/108389 A1

- (51) International Patent Classification⁷: **B29C 45/27**, 45/73
- (21) International Application Number: PCT/CA2004/000654
- (22) International Filing Date: 3 May 2004 (03.05.2004)
- (25) Filing Language: English
- (26) Publication Language: English
- (30) Priority Data: 10/455,469 5 June 2003 (05.06.2003) US
- (71) Applicant (for all designated States except US): **HUSKY INJECTION MOLDING SYSTEMS LTD.** [CA/CA]; 500 Queen Street South, Bolton, ontario L7E 5S5 (CA).
- (72) Inventor; and
- (75) Inventor/Applicant (for US only): **ELLIOTT, Gordon** [CA/CA]; 3 Burkston Place, Toronto, Ontario M9B 3E4 (CA).
- (74) Agent: **SMITH, Derek, K. W.**; Husky Injection Molding Systems Ltd., 500 Queen Street South, Bolton, Ontario L7E 5S5 (CA).
- (81) Designated States (unless otherwise indicated, for every kind of national protection available): AE, AG, AL, AM, AT, AU, AZ, BA, BB, BG, BR, BW, BY, BZ, CA, CH, CN, CO, CR, CU, CZ, DE, DK, DM, DZ, EC, EE, EG, ES, FI, GB, GD, GE, GH, GM, HR, HU, ID, IL, IN, IS, JP, KE, KG, KP, KR, KZ, LC, LK, LR, LS, LT, LU, LV, MA, MD, MG, MK, MN, MW, MX, MZ, NA, NI, NO, NZ, OM, PG, PH, PL, PT, RO, RU, SC, SD, SE, SG, SK, SL, SY, TJ, TM, TN, TR, TT, TZ, UA, UG, US, UZ, VC, VN, YU, ZA, ZM, ZW.
- (84) Designated States (unless otherwise indicated, for every kind of regional protection available): ARIPO (BW, GH, GM, KE, LS, MW, MZ, NA, SD, SL, SZ, TZ, UG, ZM, ZW), Eurasian (AM, AZ, BY, KG, KZ, MD, RU, TJ, TM), European (AT, BE, BG, CH, CY, CZ, DE, DK, EE, ES, FI, FR, GB, GR, HU, IE, IT, LU, MC, NL, PL, PT, RO, SE, SI, SK, TR), OAPI (BF, BJ, CF, CG, CI, CM, GA, GN, GQ, GW, ML, MR, NE, SN, TD, TG).

[Continued on next page]

(54) Title: A GATE COOLING STRUCTURE IN A MOLDING STACK

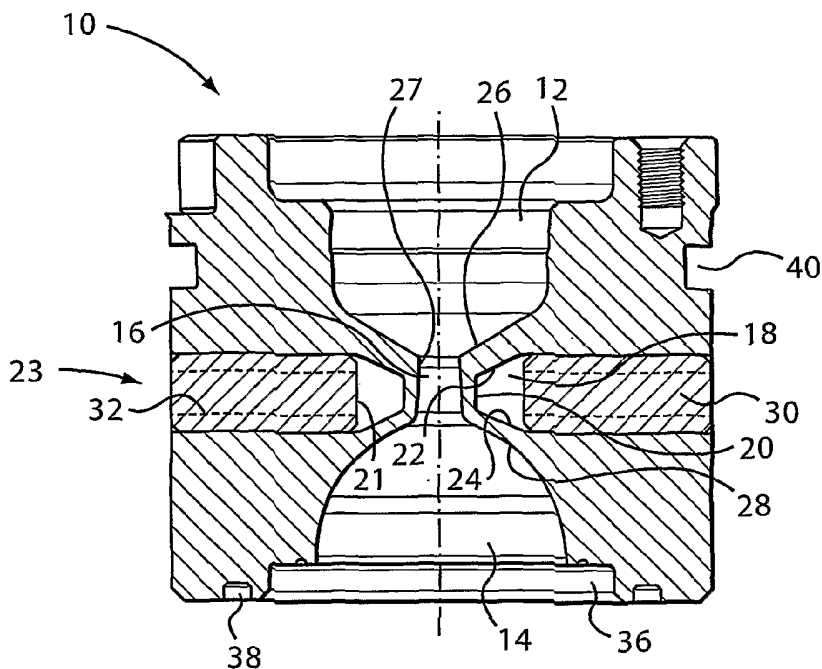

(57) Abstract: A gate insert (10, 110) for a stack assembly in an injection molding machine having a gate (16, 116) through which a melt of thermoplastics material enters a mold cavity (14, 114). The gate insert has a cooling channel (18, 118) surrounding, and substantially uniformly spaced from, the gate (16, 116). The cooling channel has an inner surface with a profile substantially parallel to the gate. The cooling channel is further defined by either a structural insert in the form of a split ring (30) or by a recess (23) in a two-piece gate insert having interconnecting surfaces (111a, 111b).

WO 2004/108389 A1

**Declaration under Rule 4.17:**

— as to applicant's entitlement to apply for and be granted a patent (Rule 4.17(ii)) for the following designations AE, AG, AL, AM, AT, AU, AZ, BA, BB, BG, BR, BW, BY, BZ, CA, CH, CN, CO, CR, CU, CZ, DE, DK, DM, DZ, EC, EE, EG, ES, FI, GB, GD, GE, GH, GM, HR, HU, ID, IL, IN, IS, JP, KE, KG, KP, KR, KZ, LC, LK, LR, LS, LT, LU, LV, MA, MD, MG, MK, MN, MW, MX, MZ, NA, NI, NO, NZ, OM, PG, PH, PL, PT, RO, RU, SC, SD, SE, SG, SK, SL, SY, TJ, TM, TN, TR, TT, TZ, UA, UG, UZ, VC, VN, YU, ZA, ZM, ZW, ARIPO patent (BW, GH, GM, KE, LS, MW, MZ, NA, SD, SL, SZ, TZ, UG, ZM, ZW), Eurasian patent (AM, AZ,

BY, KG, KZ, MD, RU, TJ, TM), European patent (AT, BE, BG, CH, CY, CZ, DE, DK, EE, ES, FI, FR, GB, GR, HU, IE, IT, LU, MC, NL, PL, PT, RO, SE, SI, SK, TR), OAPI patent (BF, BJ, CF, CG, CI, CM, GA, GN, GQ, GW, ML, MR, NE, SN, TD, TG)

Published:

— with international search report

For two-letter codes and other abbreviations, refer to the "Guidance Notes on Codes and Abbreviations" appearing at the beginning of each regular issue of the PCT Gazette.

A GATE COOLING STRUCTURE IN A MOLDING STACK**TECHNICAL FIELD**

5 The invention relates in general to a molding stack and is particularly, but not exclusively, applicable to a stack component used within a stack of an injection mold. In particular, it relates to a gate insert having a cooling channel surrounding the gate to improve heat transfer for
10 cooling the mold.

BACKGROUND OF THE INVENTION

As is commonly known, a molding stack for injection molding a
15 preform typically includes a core, a neck ring pair, a cavity, and a gate insert. The gate insert typically has a narrow cylindrical passage called a gate, through which a melt of thermoplastic material enters a cooled molding cavity. The time required to cool the melt of plastic contained in the
20 gate, after the mold cavity has been filled and packed, often dictates the duration of the cooling phase of the molding cycle, and is a direct result of having started cooling last; and, due to the fact that the gate sits adjacent a heated hot runner nozzle (i.e. nozzle tip/insulator interface) and is
25 therefore difficult to cool. This is particularly true of preform molds with extended gates. An extended gate produces a preform with an extended nub, the purpose of which is to encapsulate any imperfections in the nub. A portion of the nub may be trimmed in a post-mold process.

30

In the case of PET preforms, common manufacturing defects are:

Crystallinity: the resin recrystallizes due to the elevated temperature of the core resin not cooling quickly enough. The
35 white appearance of the crystals impairs the clarity of the final product and provides an area of potential weakness in a resultant blown product, especially in the gate region.

Surface blemishes: the ejected preforms, initially having
40 solidified surfaces, are reheated by the bulk/core material,

which causes the surface to soften and be easily marked. The insulation properties of the plastic support, over time, the migration of heat to the surface of the preform to cause the surface reheating effect. Sometimes this surface reheating can be severe enough to cause touching parts to weld together.

Geometric inaccuracies: handling partly-cooled preforms or attempting to further cool them in devices that do not maintain their geometric shape while their surfaces are reheated can cause the preform's round diameter to become oval shaped or the smooth surface to become wrinkled or non-linear. Uniform cooling of the part is therefore important.

The above-noted problems can be alleviated somewhat by extending the cooling time of the injection molded preforms in their mold. However, this will cause the injection molding cycle to be lengthened, and is not desirable because cycle time increases and productivity is diminished.

One approach to overcome the aforementioned problems is to introduce a cooling structure to improve heat transfer and cooling of that part of the mold (i.e. the nub) in the gate.

This approach has been addressed in several different ways, each of which uses a cooling channel surrounding the gate.

However, in general terms, the prior art cooling channel configurations are regarded as having less than optimal heat transfer between the melt in the gate and the coolant in the cooling channel, due to excessive separation distance therebetween, that in turn dictates a longer cooling/cycle time. The excessive separation distance is often a result of having to provide the gate insert with a load bearing structure necessary to accommodate the high compressive mold clamping force that acts therethrough. The two most commonly known gate insert configurations include a cooling channel configuration that is either a circumferential groove or a diamond-drilling pattern.

The circumferential groove-cooling channel is typically formed from the outside surface of the gate insert adjacent the gate. The size of the cooling channel is quite limited in that it is desirable, from a flow dynamics perspective, to match the cumulative cross-sectional area of the flow paths around the gate to that of the source/sink coolant supply channels, provided through a cavity plate. Further, the maximum depth and overall profile of the groove is generally dictated by the configuration of the resultant web, between the groove and the gate, that must be capable of withstanding the applied mold clamping force without permanent deformation. In practice, the required size of the web dictates a relatively large separation distance between the cooling channel and the gate and as such does not provide for optimal gate cooling efficiency.

Alternatively, the diamond drilling cooling channel provides a crude approximation of a toroidal channel surrounding the gate, and is a resultant of an array of intersecting coplanar drill lines. The resultant flow channel is typically six-sided, as is considered to be the practical design limit. Again, the size of the cooling channel is chosen, from a flow dynamics perspective, to match the cumulative cross-sectional area of the flow paths around the gate to that of the source/sink coolant supply channels. Further, the crude form of the toroidal cooling channel dictates that the separation distance between the cooling channel and the gate varies along the flow path, and hence the optimal heat transfer occurs only at a limited number of points, six in the typical case. More particularly, non-uniform cooling can adversely affect port quality.

A further alternative is illustrated in DE 10024625, which proposes a copper alloy insert ring containing "diamond drilled" cooling channels. The channels result in non-linear heat transfer across the gate, which is undesirable. Furthermore, by choosing an insert ring an extra heat resistor is introduced due to the gap between stainless steel gate and copper alloy ring, thereby potentially reducing total heat transfer. The choice of copper may also critically impact the

structural soundness of the gate when subjected to the high loads, in use.

The present invention and its preferred embodiments seek to overcome or at least mitigate the problems of the prior art.

SUMMARY OF THE INVENTION

One aspect of the invention provides a gate insert for a stack assembly of a mold, the gate insert having a gate through which, in use, melt material can enter a mold cavity. The gate insert has a cooling channel surrounding the gate and a coolant passageway connecting, in use, the cooling channel to a coolant supply. The cooling channel is shaped to follow the profile of at least part of the gate and spaced by a substantially uniform distance from the surface of the gate.

Optionally, the cooling channel is further shaped to follow the profile of an upper part of the mold cavity adjacent the gate. Preferably, the cooling channel is further shaped to follow the profile of a nozzle interface adjacent the gate.

In some embodiments, the cooling channel is annular in shape. The coolant passageway may be provided by an inflow passage and an outflow passage, each connected to the cooling channel. Each passage is preferably of equal diameter to match coolant flow through the cooling passage.

In one class of embodiments, the gate insert is formed from two halves: a nozzle half and a molding half, each half having a surface to be interconnected to the other half. Preferably, the cooling channel and the coolant passageway are formed from recesses in the interconnecting surface of either or both halves.

A second aspect of the invention provides for a gate insert for a stack assembly in an injection molding machine, the gate insert having a gate through which a melt of material enters a mold cavity. The gate insert has a cooling channel formed in a recess surrounding the gate and a structural insert in the

recess to support the gate insert and to define a coolant passageway to connect the cooling channel to a coolant supply. The cooling channel has an inner surface with a profile substantially defined by a surface adjacent to the gate. The cooling channel is substantially uniformly spaced about the gate.

In some embodiments, the outer surface of the cooling channel is defined by an inner surface of the structural insert.

Preferably, the structural insert is provided by a split ring and the coolant passageway may be defined in the opposed mating surfaces of the split ring.

A third aspect of the invention provides a stack assembly in an injection molding machine having a gate through which a melt of thermoplastics material enters a mold cavity adjacent the gate. The gate is surrounded by a cooling channel, the cooling channel is defined at least in part by a first surface which is substantially parallel to and spaced from a surface of the gate to provide substantially uniform heat transfer between the aforesaid surfaces.

According to a preferred feature of the third aspect of the invention, the cooling channel is further defined by a second surface substantially parallel to and spaced from an upper part of the mold cavity. Optionally, the cooling channel is further defined by a third surface substantially parallel to and spaced from the surface forming a nozzle interface. The distance between the first surface of the cooling channel and the surface of the gate; the second surface and the surface of the upper part of the mold cavity; and/or the third surface and the surface of the nozzle interface is preferably greater than 2 mm.

BRIEF DESCRIPTION OF THE DRAWINGS

Exemplary embodiments of the present invention will now be described with reference to the accompanying drawings, in which:

FIG. 1 illustrates a first embodiment of the gate insert structure, viewed in cross-section;

5 FIG. 2 is a top plan view of the structural insert to be used with the gate insert of Fig. 1;

FIG. 3 is an end elevation of the structural insert to be used with the gate insert of Fig. 1;

10 FIG. 4 illustrates a second embodiment of the gate insert structure, viewed in cross-section; and

FIG. 5 is a cross-section view taken along line 5-5 of Fig. 4 and illustrates a top plan view of the molding half of the gate insert.

DETAILED DESCRIPTION OF THE PREFERRED EMBODIMENT(S)

20 As mentioned above, a mold stack in an injection molded machine includes a gate. The gate is preferably encapsulated in a gate insert. The gate insert is a component that has an aperture through it with three portions: a hot runner nozzle interface, a molding cavity and a gate. The gate is arranged between, and
25 connects, the nozzle interface and the molding cavity. In this example the molding cavity is for forming the domed end portion of a preform.

Turning to the first embodiment of gate insert shown in Figs 1, 2 and 3, there is shown a gate insert 10 for a stack assembly. The gate insert 10 is a unitary item, although as described below, it could be manufactured from two or more parts, without departing from the scope of invention. The gate insert 10 has an aperture through it comprised of three portions: a nozzle
35 interface 12, an upper part of a mold cavity 14, and a gate 16 which interconnects the nozzle interface and mold cavity. The gate 16 could be elongated to constitute an extended gate.

A coolant channel 18 is provided proximate the gate 16 between
40 the nozzle interface 12, the mold cavity 14 and a structural

insert 30. In particular, the coolant channel 18 surrounds the gate 16, in close proximity to it. It will be seen from Fig. 1 that the coolant channel 18 is shaped to follow substantially the profile of the gate 16. Preferably the coolant channel 18 is also shaped to follow the profile of the surfaces of the nozzle interface 12 and mold cavity 14 adjacent the gate. Therefore, it will be seen from Fig. 1 that the coolant channel 18 is defined in part by three surfaces 20, 22 and 24. Surface 20 is substantially parallel to the surface 27 of the gate 16; surface 22 is substantially parallel to the surface 26 which partially defines the nozzle interface 12; and surface 24 is substantially parallel to the upper surface 28 of the mold cavity 14.

Preferably the distance between the coolant channel surfaces 20, 22 and 24 and the respective gate insert surfaces 27, 26, and 28 is substantially uniform. In the preferred embodiment, the optimum distance between those surfaces is approximately 2 millimetres so as to avoid mechanical failure from injection pressures and axial clamping forces.

It is envisaged that the coolant channel 18 can be profiled to any design distance according to the required cooling rates for the gate, thereby to minimise the crystallinity while at the same time balancing the likelihood of surface blemishes or geometric inaccuracies occurring by reducing the cycle time.

In the first embodiment illustrated in Fig. 1, the coolant channel 18 is manufactured by machining or otherwise forming a recess 23 including surfaces 20, 22, and 24 externally of the gate 16. In order to support the gate insert 10, a structural insert 30 is inserted in the recess. It is the structural insert 30 that provides further definition of the coolant channel 18 by defining an outer wall 21 of the coolant channel 18. The structural insert is therefore of an annular configuration.

In the preferred embodiment, the structural insert 30 is in the form of a split ring, shown in Figs. 2 and 3 in which inflow and outflow coolant passageways 32 are provided, thereby

communicating cooling fluid through the exterior surface 21 of the coolant channel 18. Fig. 2 illustrates the split line 34 of the split ring. The split ring 30 is manufactured of similar material to the gate insert, for example stainless steel, and fits closely within the recess 23 to provide support to the gate insert 10 when vertical forces are exerted through the molding stack components. Preferably, the coolant passageways 32 are sized so as to match the inflow and outflow coolant channels in a cavity plate that receives gate insert 10, thereby to optimise the channel volume and maintain the coolant medium velocity. Preferably, the inflow and outflow passageways 32 match the standard locations of the coolant channels in the cavity plate (not shown). The passageways 32 are directed along the split line 34 of the split ring 30 for the sake of ease of manufacture, alternatively they could be formed through the split ring 30.

In one class of embodiments, the gate insert is provided with a spigot 36 for engaging with a mold cavity and suitable O-ring grooves 38, 40 are provided, shown in Fig. 1, for receiving O-rings so as to provide "wet/dry" surfaces.

A second embodiment is illustrated in Figs. 4 and 5. The second embodiment is similar to the first embodiment, with like parts being identified with like reference numerals, but with the prefix '1'.

In this embodiment, the gate insert 110 is manufactured from bonded halves, namely a nozzle half 111a and a molding half, 111b. The desired cooling channel 118 and coolant passageways 132 are milled, or otherwise formed, as a recess from the interfacing surfaces 113, shown in Fig. 5. Thereafter the nozzle half 111a and the molding half 111b are bonded by suitable known means, for example vacuum brazing, described in more detail in US Patent 5855983 the content of which is incorporated herein by reference. In contrast with the 3-part structure of Figs 1 to 3, Figs 4 and 5 benefit from a reduced port count and fewer thermal/physical interfaces arising from a 2-part design.

Again, the gate insert 110 has an aperture through it comprised of three portions: a nozzle interface 112, an upper part of mold cavity 114, and a gate 116 which interconnects the nozzle interface and mold cavity.

5

A coolant channel 118 is provided proximate the gate 116 between the nozzle interface 112 and the mold cavity 114. Like the first embodiment, the coolant channel 118 surrounds the gate 116, in close proximity to it. It will be seen from Fig. 4 that the coolant channel 118 is shaped to follow the profile of the gate. Preferably the coolant channel 118 is also shaped to follow the profile of the surfaces of the nozzle interface 112 and mold cavity 114 adjacent the gate. Therefore, it will be seen from Fig. 4 that the coolant channel 118 is defined by four surfaces 120, 122 and 124. Surface 120 is substantially parallel to the surface 127 of the gate 116. Surface 122 is substantially parallel to the surface 126, which partially defines the nozzle interface 112. Surface 124 is substantially parallel to the upper surface 128 of the mold cavity 114 and surface 121 defines a radially outwardly (or exterior) spaced surface from surface 120. As with the previous embodiment, preferably the distance between the coolant channel surfaces 120, 122, and 124 and the respective gate insert surfaces 127, 126, and 128 is also substantially uniform.

25

As mentioned above, the coolant channel 118 is, for example, milled as a recess from the interconnecting surfaces of each half of the gate insert 110. Therefore no structural insert is required in this embodiment. The inflow and outflow coolant passageways 132 are also milled as a recess from the same surfaces, thereby providing for fluid communication through the exterior surface 121 of the coolant channel 18. Preferably, the coolant passageways 132 are sized so as to match the inflow and outflow coolant channels in a cavity plate that receives gate insert 10, thereby to optimise the channel volume and maintain the coolant medium velocity. Again the inflow and outflow passageways 32 can be positioned to match the standard locations of the coolant channels in the cavity plate.

35

Like the first embodiment, the insert gate 110 is provided with a spigot 136 for engaging with the mold cavity and suitable O-ring grooves 138, 140 are provided in the insert gate for receiving O-rings so as to provide "wet/dry" surfaces.

5

Thus there is provided a gate insert 10, 110 for a stack assembly in a mold having a gate 16, 116 through which a melt of plastic material enters a mold cavity 14, 114 the gate insert having a cooling channel 18, 118 surrounding the gate 16, 116, which cooling channel is shaped to follow the profile of at least part of said gate 16, 116 and spaced by a substantially uniform distance from the surface of the gate.

Beneficially, this concept provides a capability of profiled cooling channels to any desired distance from the cooling medium to the preform molding surface, extended gate nub if it exists, and nozzle tip/insulator interface surfaces. Furthermore with the gate 16, 116 now being defined by a structural configuration that intrinsically returns, i.e., maximises, the use of a commonly used metal or alloy, improved structural stability in the gate insert is achieved.

Furthermore, the coolant medium is in close thermal contact with the gate thereby to maximise heat transfer. Also, the heat transfer is adjustable by profiling the location adjacent the gate nub, preform body and/or gate nozzle area by adjusting the location of the coolant channels.

The present invention and its preferred embodiments can be incorporated into the existing designs to be supplied to new molding stack or supplied on a retrofit basis, thus allowing the cooling improvement to be applied to existing molds.

It is envisaged that the various changes may be made within the scope of the present invention, for example, the size and shape of the coolant channels may be adjusted to the shape of the gate, mold cavity and/or nozzle interface. For example, the structural configuration of the gate and coolant passageway of the present invention can find application in technologies working with

different materials than plastic, eg thixotropic system working with metal alloys.

5 Obviously, the gate cooling structure of the present invention
is applicable to alternative configurations of the gate insert
10 that may not include a spigot 36.

WHAT IS CLAIMED IS:

1. A gate insert for a stack assembly of a mold, the gate insert having a gate through which, in use, melt material can enter a mold cavity, the gate insert having a cooling channel surrounding the gate and a coolant passageway connecting, in use, the cooling channel to a coolant supply, the cooling channel is shaped to follow a profile of at least part of said gate and spaced by a substantially uniform distance from a surface of the gate.
2. The gate insert of claim 1, wherein the cooling channel is further shaped to follow a profile of an upper part of the mold cavity adjacent the gate.
3. The gate insert of claim 1, wherein the cooling channel is further shaped to follow a profile of a nozzle interface adjacent the gate.
4. The gate insert of claim 1, wherein the coolant passageway comprises an inflow passageway and an outflow passageway, each passageway being connected to the cooling channel.
5. The gate insert of claim 1, wherein the gate insert comprises a nozzle half and a molding half, each with interconnecting surfaces.
6. The gate insert of claim 5, wherein the cooling channel and the coolant passageway are formed from a recess at the interconnecting surfaces of the nozzle half and molding half.
7. The gate insert of claim 6, wherein a portion of the recess is provided on each interconnecting surface of the nozzle half and molding half.
8. A gate insert for a stack assembly in an injection molding machine, the gate insert having a gate through which a melt enters a mold cavity, the gate insert having a cooling channel formed in a recess surrounding the gate and a

structural insert in the recess to support the gate insert and to define a coolant passageway that, in use, connects the cooling channel to a coolant supply, the cooling channel having an inner surface with a profile partially defined by a surface spaced substantially uniformly from the gate.

9. The gate insert of claim 8, wherein an outer surface of the cooling channel is defined by an inner surface of the structural insert.

10. The gate insert of claim 9, wherein the structural insert is a split ring.

11. The gate insert of claim 10, wherein the split ring and the gate insert are both manufactured from identical material.

12. The gate insert of claim 10, wherein the coolant passageway is defined in opposed mating surfaces of the split ring.

13. A stack assembly in an injection mold, the stack assembly including a gate through which a melt of plastic material enters a mold cavity adjacent the gate, the gate being surrounded by a cooling channel, the cooling channel defined at least in part by a first surface which is substantially parallel to and spaced from a surface of the gate to provide substantially uniform heat transfer between the aforesaid surfaces.

14. The assembly of claim 13, wherein the cooling channel is further defined by a second surface substantially parallel to and spaced from an upper part of the mold cavity.

15. The assembly of claim 14, further comprising a nozzle interface portion adjacent the gate wherein the cooling channel is further defined by a third surface substantially parallel to and spaced from a surface forming the nozzle interface portion.

16. The assembly of claim 15, wherein a distance between any one of:

the first surface of the cooling channel and the surface
of the gate;

the second surface and the surface of the upper part of
the mold cavity; and

5 the third surface and the surface of the nozzle interface;
is greater than 2 mm.

17. The gate insert of claim 8, wherein the gate insert is in
an injection mold.

10

18. The gate insert of claim 8, wherein the mold is in an
injection molding machine.

15

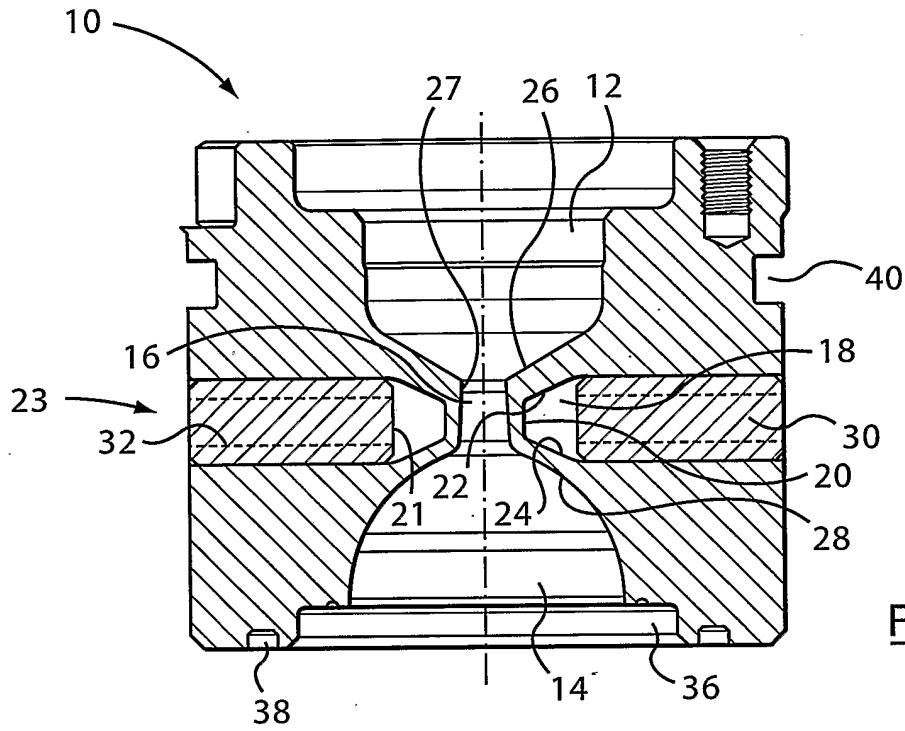

FIG. 1

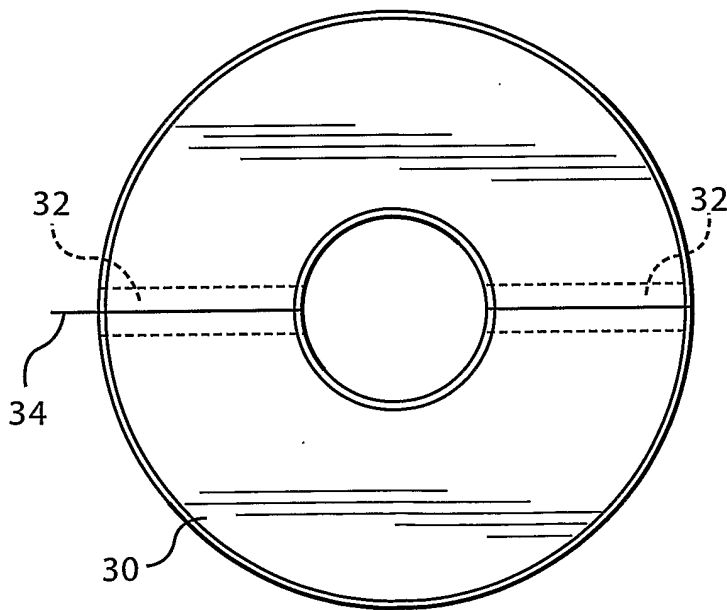

FIG. 2

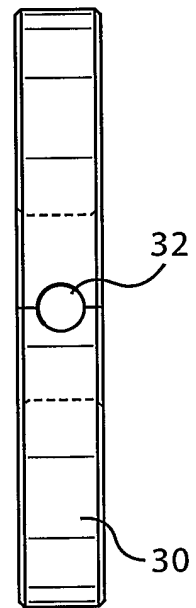

FIG. 3

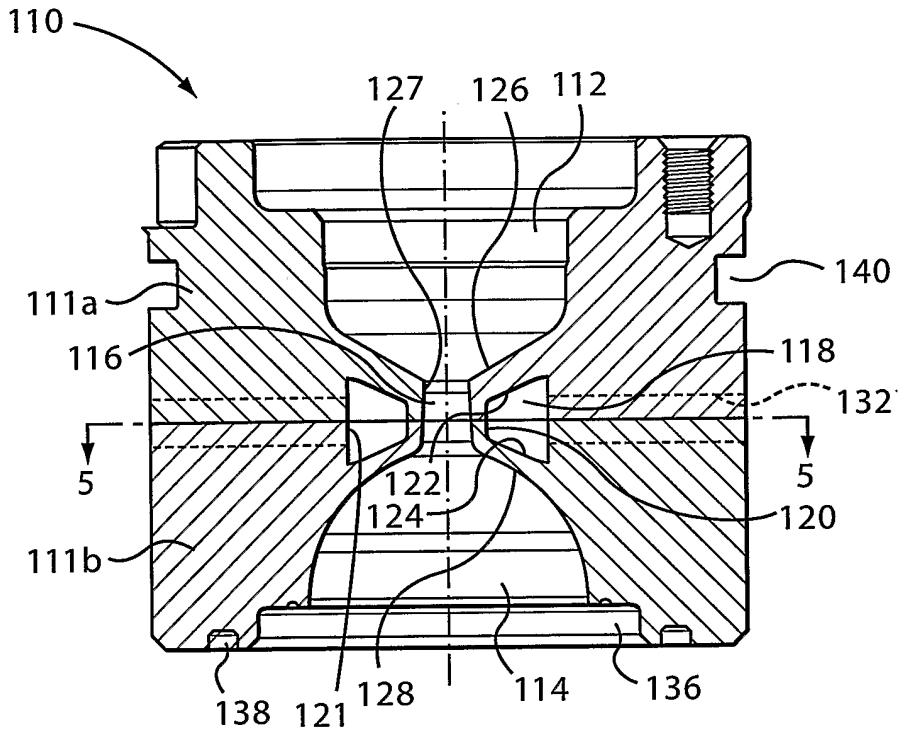

FIG. 4

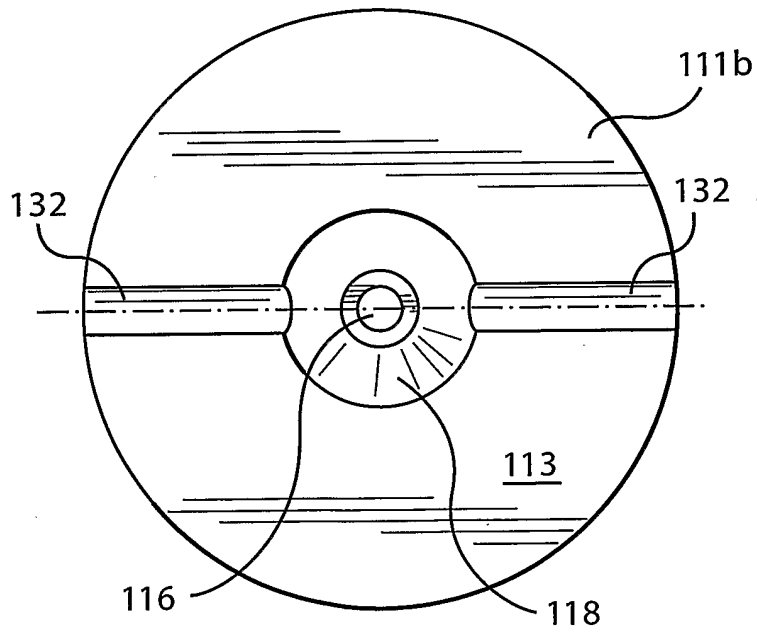

FIG. 5

INTERNATIONAL SEARCH REPORT

International Application No
PCT/CA2004/000654

A. CLASSIFICATION OF SUBJECT MATTER
IPC 7 B29C45/27 B29C45/73

According to International Patent Classification (IPC) or to both national classification and IPC

B. FIELDS SEARCHED

Minimum documentation searched (classification system followed by classification symbols)
IPC 7 B29C

Documentation searched other than minimum documentation to the extent that such documents are included in the fields searched

Electronic data base consulted during the international search (name of data base and, where practical, search terms used)

EPO-Internal, WPI Data, PAJ

C. DOCUMENTS CONSIDERED TO BE RELEVANT

Category °	Citation of document, with indication, where appropriate, of the relevant passages	Relevant to claim No.
X	US 6 569 370 B1 (AMIN NADEEM ET AL) 27 May 2003 (2003-05-27) figures 1-5	1-4, 13-15
E	WO 2004/043675 A (LEE ROBERT A ; ADVANCED PLASTICS TECHNOLOGIES (GB); HUTCHINSON GERALD) 27 May 2004 (2004-05-27) paragraph '0186!; figure 20	1, 2, 4, 13, 14
X	DE 100 24 625 A (MOLD & HOTRUNNER TECHNOLOGY GM) 22 November 2001 (2001-11-22) cited in the application	8-12
A	column 5, line 14 - column 6, line 24; figures 3,4	4-7
	----- -/--	

Further documents are listed in the continuation of box C.

Patent family members are listed in annex.

° Special categories of cited documents :

- *A* document defining the general state of the art which is not considered to be of particular relevance
- *E* earlier document but published on or after the international filing date
- *L* document which may throw doubts on priority claim(s) or which is cited to establish the publication date of another citation or other special reason (as specified)
- *O* document referring to an oral disclosure, use, exhibition or other means
- *P* document published prior to the international filing date but later than the priority date claimed

- *T* later document published after the international filing date or priority date and not in conflict with the application but cited to understand the principle or theory underlying the invention
- *X* document of particular relevance; the claimed invention cannot be considered novel or cannot be considered to involve an inventive step when the document is taken alone
- *Y* document of particular relevance; the claimed invention cannot be considered to involve an inventive step when the document is combined with one or more other such documents, such combination being obvious to a person skilled in the art.
- *&* document member of the same patent family

Date of the actual completion of the international search

11 August 2004

Date of mailing of the international search report

18/08/2004

Name and mailing address of the ISA
European Patent Office, P.B. 5818 Patentlaan 2
NL - 2280 HV Rijswijk
Tel. (+31-70) 340-2040, Tx. 31 651 epo nl,
Fax: (+31-70) 340-3016

Authorized officer

Zattoni, F

INTERNATIONAL SEARCH REPORT

International Application No
PCT/CA2004/000654

C.(Continuation) DOCUMENTS CONSIDERED TO BE RELEVANT		
Category °	Citation of document, with indication, where appropriate, of the relevant passages	Relevant to claim No.
A	US 5 443 381 A (GELLERT JOBST U) 22 August 1995 (1995-08-22) column 3, line 44 - column 4, line 52; figures 2,5 -----	1,8,13
A	EP 0 933 186 A (MOLD MASTERS LTD) 4 August 1999 (1999-08-04) paragraph '0013! - paragraph '0014!; figure 3 -----	1,8,13

INTERNATIONAL SEARCH REPORT

International Application No
PCT/CA2004/000654

Patent document cited in search report		Publication date	Patent family member(s)	Publication date
US 6569370	B1	27-05-2003	AU 4214501 A WO 0189797 A1 CA 2406915 A1 TW 506888 B	03-12-2001 29-11-2001 29-11-2001 21-10-2002
WO 2004043675	A	27-05-2004	WO 2004043675 A1	27-05-2004
DE 10024625	A	22-11-2001	DE 10024625 A1	22-11-2001
US 5443381	A	22-08-1995	NONE	
EP 0933186	A	04-08-1999	CA 2228458 A1 AT 253443 T BR 9900392 A CN 1229712 A ,B DE 19903574 A1 DE 69912485 D1 DE 69912485 T2 EP 0933186 A1 ES 2210867 T3 JP 2000202884 A US 6017209 A	02-08-1999 15-11-2003 28-12-1999 29-09-1999 05-08-1999 11-12-2003 13-05-2004 04-08-1999 01-07-2004 25-07-2000 25-01-2000