

Newell & Pinn,

Metal Chuck.

No. 102,577.

Patented May 3, 1870.

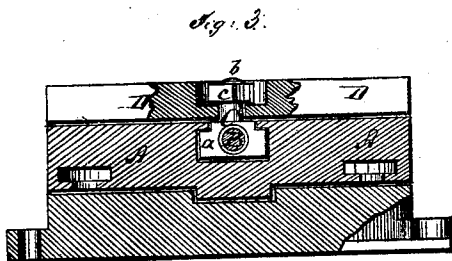
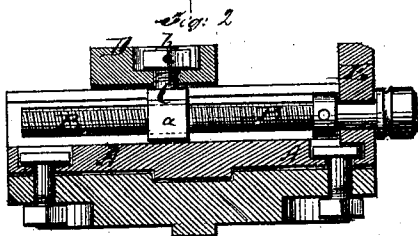
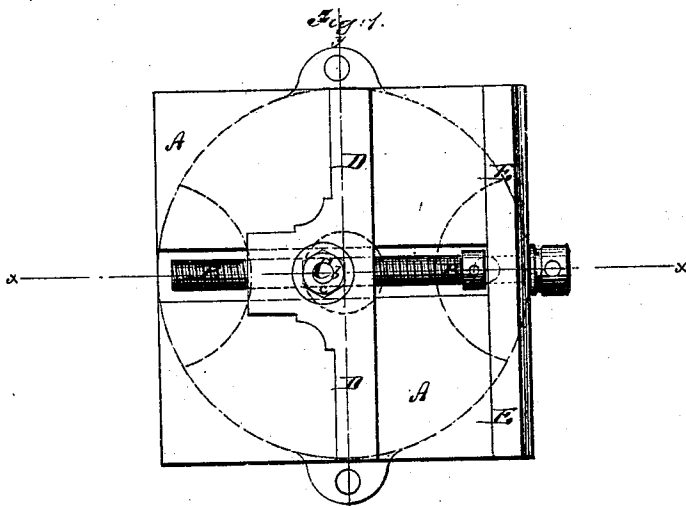

Witnesses:

Chas. Nida.
L. S. Mabee

Inventor:

A. Newell
Wm Pinn
PER *M. M. Co.*
Attorneys.

United States Patent Office.

AUGUSTUS NEWELL AND WILLIAM PIM, OF CHICAGO, ILLINOIS.

Letters Patent No. 102,577, dated May 3, 1870.

IMPROVED PLANING-CHUCK.

The Schedule referred to in these Letters Patent and making part of the same.

To all whom it may concern:

Be it known that we, AUGUSTUS NEWELL and WILLIAM PIM, of Chicago, in the county of Cook and State of Illinois, have invented a new and Improved Planing-Chuck; and we do hereby declare that the following is a full, clear and exact description thereof, which will enable others skilled in the art to make and use the same, reference being had to the accompanying drawing forming part of this specification, in which—

Figure 1 represents a plan, or top view, of our improved chuck.

Figure 2 is a vertical longitudinal section of the same, taken on the plane of the line *x z*, fig. 1.

Figure 3 is a vertical transverse section of the same, taken on the plane of the line *y y*, fig. 1.

Similar letters of reference indicate corresponding parts.

This invention relates to a new "chuck" or "vise," to be used on a lathe or planer, its chief object being to hold the work perfectly true.

The invention consists in the arrangement and combination of the leading-screw and swivel-bed, with a T-bolt, a movable jaw, all parts operating so that the article to be planed cannot be upset, but will be held perfectly true, as hereinafter more fully set forth.

A, in the drawing, represents the swivel-bed of the chuck, which is arranged on a planer.

In this bed is swiveled the leader-screw B, which works in a groove of the bed, as shown.

Upon the screw is fitted a nut, *a*, which can be moved longitudinally, but not revolved in the groove of the bed, it filling the said groove transversely in such manner that it cannot revolve in the same.

From the nut *a* projects a pin, *b*, which has a screw-thread at its upper part.

The pin *b* and nut *a*, together, constitute the T-bolt C, upon which the movable jaw D is swiveled, the said jaw being held down upon the face of the bed by means of a nut, *c*, that is screwed upon the pin *b*, as shown.

The fixed jaw E projects from, and is firmly secured to, or formed on, the bed A, at right angles to the screw B, as shown in fig. 1.

By means of the screw B the jaw D can be adjusted at any suitable distance from the jaw E, and, at the same time, the jaw D can turn on the pin *b*, so as to hold wedge-shaped as well as parallel-faced articles.

By straining the nut *c*, the jaw D will be clamped in such manner that it cannot spring the least from the bed. The work will, therefore, be held quite true, and will be planed accordingly.

In the ordinary chucks, when a piece is to be fastened, the set-screws bearing against the movable jaw at some point above the bed, spring the work slightly from the bed at one side, and cause the operation to be more or less untrue. By our invention this objection is entirely overcome.

Having thus described our invention,

We claim as new and desire to secure by Letters Patent—

The self-adjusting jaw D, carrying-bolt C, and clamping-nut *c*, combined with bed A and screw B, all arranged and relatively constructed as and for the purpose described.

AUGUSTUS NEWELL.
WILLIAM PIM.

Witnesses:

HENRY F. TALBOT,
H. R. MOORE.