



(51) International Patent Classification:

F21S 8/08 (2006.01) H01Q 1/12 (2006.01)
F21V 21/10 (2006.01) H01Q 3/04 (2006.01)

(21) International Application Number:

PCT/EP2018/073208

(22) International Filing Date:

29 August 2018 (29.08.2018)

(25) Filing Language:

English

(26) Publication Language:

English

(30) Priority Data:

2017/5597 29 August 2017 (29.08.2017) BE
2017/5598 29 August 2017 (29.08.2017) BE
2017/5599 29 August 2017 (29.08.2017) BE
2018/5411 18 June 2018 (18.06.2018) BE

(71) Applicant: SCHREDER S.A. [BE/BE]; Rue de Lusambo 67, 1190 Bruxelles (BE).

(72) Inventors: GIROUARD, Stéphane; Chemin de la Queue 6, 4670 Mortier (BE). PLUIMERS, Guy; Rue Jean Volders 30, 4340 Awans (BE). DAMOISEAU, Hervé; Rue de Saive 34, 4671 Saive (BE).

(74) Agent: D'HALLEWEYN, Nele Veerle Trees Gertrudis; Bezuidenhousweg 57, 2594 AC Den Haag (NL).

(81) Designated States (unless otherwise indicated, for every kind of national protection available): AE, AG, AL, AM, AO, AT, AU, AZ, BA, BB, BG, BH, BN, BR, BW, BY, BZ, CA, CH, CL, CN, CO, CR, CU, CZ, DE, DJ, DK, DM, DO, DZ, EC, EE, EG, ES, FI, GB, GD, GE, GH, GM, GT, HN, HR, HU, ID, IL, IN, IR, IS, JO, JP, KE, KG, KH, KN, KP, KR, KW, KZ, LA, LC, LK, LR, LS, LU, LY, MA, MD, ME, MG, MK, MN, MW, MX, MY, MZ, NA, NG, NI, NO, NZ, OM, PA, PE, PG, PH, PL, PT, QA, RO, RS, RU, RW, SA, SC, SD, SE, SG, SK, SL, SM, ST, SV, SY, TH, TJ, TM, TN, TR, TT, TZ, UA, UG, US, UZ, VC, VN, ZA, ZM, ZW.

(84) Designated States (unless otherwise indicated, for every kind of regional protection available): ARIPO (BW, GH, GM, KE, LR, LS, MW, MZ, NA, RW, SD, SL, ST, SZ, TZ, UG, ZM, ZW), Eurasian (AM, AZ, BY, KG, KZ, RU, TJ, TM), European (AL, AT, BE, BG, CH, CY, CZ, DE, DK, EE, ES, FI, FR, GB, GR, HR, HU, IE, IS, IT, LT, LU, LV, MC, MK, MT, NL, NO, PL, PT, RO, RS, SE, SI, SK, SM, TR), OAPI (BF, BJ, CF, CG, CI, CM, GA, GN, GQ, GW, KM, ML, MR, NE, SN, TD, TG).

(54) Title: LAMP POST WITH FUNCTIONAL MODULES

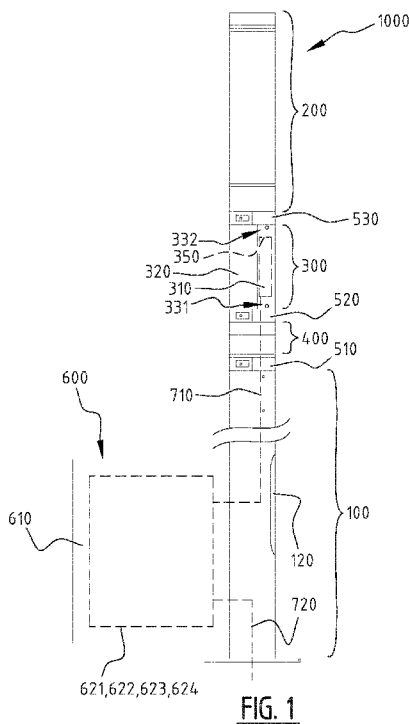

(57) Abstract: A lamp post comprising a support pole; a light module supported by the support pole, said light module comprising a light source; an antenna module supported by the support pole; said antenna module comprising an antenna configured for receiving and emitting cellular data; and a base station module; wherein the base station module comprises a housing and base station circuitry mounted in said housing; wherein the base station circuitry is coupled to the antenna; wherein the base station module is attached to an external surface of the support pole and carried by the support pole.



WO 2019/043045 A1

Published:

- *with international search report (Art. 21(3))*
- *before the expiration of the time limit for amending the claims and to be republished in the event of receipt of amendments (Rule 48.2(h))*

Lamp post with functional modules

Field of Invention

The field of the invention relates to lamp posts, in particular lamp post in the form of outdoor
5 luminaires. Particular embodiments relate to the field of modular lamp posts comprising a number
of functional modules.

Background

EP 3 076 073 B1 in the name of the applicant discloses a modular lamp post which is readily
10 assembled and installed in the field whilst providing rigidity, structural integrity and sealing. The
lamp post comprises a plurality of modules mounted on a support pole. The modules are connected
to one another by respective module connectors and one module thereof is connected to the support
pole by a module connector. EP 3 076 073 B1 is included herein by reference.

15 Further it is known to include base station functionalities in separate cabinets adjacent a lamp post,
wherein an antenna module is attached to the lamp post.

Summary

The object of embodiments of the invention is to provide an improved lamp post allowing
20 integrating additional functionalities such as base station functionalities in the lamp post. The
object of particular embodiments is to allow integrating base station functionalities in existing
lamp posts in an improved manner.

According to a first aspect of the invention there is provided a lamp post comprising a support
25 pole, a light module, an antenna module and a base station module. The light module is supported
by the support pole, and comprises a light source. The antenna module is supported by the support
pole, and comprises an antenna configured for receiving and emitting cellular data. The base
station module comprises a housing and base station circuitry mounted in said housing. The base
station circuitry is coupled to the antenna. The base station module is attached to an external
30 surface of the support pole and is carried and supported by the support pole.

Embodiments are based *inter alia* on the inventive insight that by attaching the base station module
to an external surface of the support pole such that the base station module is carried by the support
pole, it is not necessary to provide an additional foundation for the base station module contrary to
35 prior art solutions which require an additional cabinet adjacent the support pole. The inventors
realized that typical support poles of lamp posts are capable of supporting the weight of typical

base station circuitry in a sort of “side” module attached to the support pole. Also compared to prior art solution where the base station circuitry is included in the support pole, the present invention is advantageous since it does not require large dimensions for the support pole and foundation for the support pole.

5

It is noted that the term “supported” as in “the light module is supported by the support pole” and “the antenna module is supported by the support pole” does not imply that the light module needs to be directly fixed on the support pole; indeed, there may be intermediate modules or elements between the support pole and the light module and/or between the support pole and antenna module; the support pole supports the light module, the antenna module and any intermediate modules or elements.

10

According to an exemplary embodiment, the support pole is fixed in the ground and the housing of the base station module is at a distance above the ground. It is noted that the housing may also be in contact with the ground as long as it is carried by the support pole.

15

According to an exemplary embodiment, the housing of the base station module comprises a structurally rigid ribbed frame attached to the support pole; a fixing means for fixing the ribbed frame against an external surface of the support pole; and one or more panels attached to the ribbed frame, so as to enclose the ribbed frame. In that manner, first the ribbed frame may be fixed to the support pole, whereupon the base station circuitry may be arranged so that it is supported by the ribbed frame, and the one or more panels may be arranged to the ribbed frame. This allows for an easy assembly of the base station module. Also such a base station module can be easily added to existing lamp posts. The fixing means may be e.g. two or more screws or bolts.

20

Preferably, the ribbed frame is attached to the support pole at a first and second position being at a distance of each other seen in an axial direction of the support pole. Such a positioning ensures a robust fixation to the support pole. It is noted that the ribbed frame may also be attached at additional positions between the first and the second position at a distance of each other seen in an axial direction of the support pole.

25

According to an exemplary embodiment, the housing may be provided with one or more ventilation openings, e.g. a plurality of slits or holes. In an embodiment where the housing comprises one or more panels the plurality of slits may be arranged in the one or more panels, e.g. in two opposite panels of the housing, such that an air flow through the housing is created.

30

35

According to another exemplary embodiment the housing of the functional module, such as the base station module, comprises a bottom wall intended to be floating, a top wall and a peripheral wall between the bottom and top wall. The housing may cover or surround a portion of the support pole. The bottom wall may be provided with one or more lower air flow holes. The peripheral wall and/or said portion of the support pole, may be provided with one or more upper air flow holes.

The provision of upper and lower air flow holes creates an air flow in the housing capable of appropriately cooling the functional circuitry in the housing, such as the base station circuitry. For example, the one or more upper air flow holes may be provided in an upper half of the peripheral wall and/or in an upper half of the portion of the support pole covered or surrounded by the housing. In that manner the air flow will pass over a sufficiently large portion of the height of the housing guaranteeing an adequate cooling of the functional circuitry in the housing. According to an exemplary embodiment, the one or more upper air flow holes are provided in the peripheral wall and are formed as one or more slits, preferably elongated slits extending in a horizontal direction. Slits extending in a horizontal longitudinal direction have the advantage that less water and/or dirt will enter in the housing whilst allowing the same amount of air to flow out as compared to holes having the same surface area but being elongated in a vertical direction. The peripheral wall may be provided with one or more outwardly protruding portions above the slits in order to further reduce the possibility of water and/or dirt entering inside the housing.

According to an exemplary embodiment, the light source comprises a plurality of light emitting diodes, e.g. an array of light emitting diodes, which may be arranged on a PCB. Further, a driver for driving the plurality of light emitting diodes, optionally in combination with a dimmer may be integrated in the lamp post in any known manner.

According to an exemplary embodiment the support pole is hollow, and the support pole is provided with a removable door providing access to an inner part of said support pole, wherein said door may be arranged substantially at the same height as the base station module, preferably substantially opposite to the base station module. In that manner the base station circuitry in the base station module can be accessed through the door in the support pole. However, it is also possible to remove one or more panels of the housing, in order to access the base station circuitry. Also, using this embodiment, the access to the door is kept free for maintenance activity or access to cables or additional modules.

According to an exemplary embodiment the housing of the base station module covers a surface area of the support pole; wherein the support pole is provided in said surface area with a first hole and a second hole positioned above the first hole seen in an axial direction of the support pole. The lamp post comprises an antenna connection cable from the antenna through an inner part of the

support pole, through the second hole to the base station circuitry; and a power connection cable passing from a lower end of the support pole through the first hole to feed the base station circuitry. In that manner the antenna connection cable, e.g. a coaxial cable, can enter the base station module at a higher position than the power connection cable, resulting in shorter cable lengths and reduced interference. In an alternative embodiment, only one hole may be provided in said surface area, and both the antenna connection cable and the power connection cable may pass through said one hole.

According to an exemplary embodiment the housing of the base station module has a first width extending in a first direction perpendicular to an axial direction of the support pole, said first width being inferior to an external diameter of the support pole. In other words, the housing is relatively narrow in width, resulting in a compact module. Such an embodiment will be particularly suitable for support poles with a relatively large external diameter.

Preferably, the housing of the base station module has a second width extending in a second direction perpendicular to the first width and to an axial direction of the support pole, said second width being superior to an external diameter of the support pole, preferably at least twice the external diameter of the support pole. In other words, the housing may be relatively narrow but may protrude over a relatively longer distance (the second width) in a direction away from the support pole, such that it still has sufficient volume to enclose the base station circuitry. However, embodiments having a second width inferior to the external diameter of the support pole also fall within the scope of the invention.

In an alternative embodiment the first width may be larger than the external diameter of the support pole. Especially for smaller diameter poles such an embodiment may be useful. In a first possible embodiment the housing may extend on one side of the support pole, not surrounding the support pole. In a second possible embodiment the housing may surround the support pole. For example, the housing may have a cylindrical peripheral wall. However, in order to keep the door free, it may be preferred that the housing extends on only one side of the support pole.

It is further noted that multiple functional modules may be provided to the support pole. If the functional module does not surround the support pole, there may be provided e.g. two functional modules on opposite sides of the support pole. In other embodiments multiple functional modules may be provided one above the other, or one next to the other.

According to an exemplary embodiment the housing protrudes sideways from the external surface of the support pole in one direction, and does not surround the support pole. In that manner a housing with a more or less parallelepipedic shape or box shape can be formed, which is a suitable

shape to include the base station circuitry which usually consists of parallelepipedic or box shaped units.

5 According to an exemplary embodiment the antenna module is arranged in a position above the base station module. Generally, it is desirable to arrange the antenna module in a relatively high position. However, usually it is preferred to position the antenna module at a lower position than the light module. In other words, preferably, the antenna module is arranged between the base station module and the light module, seen in an axial direction of the support pole. In an alternative
10 embodiment the antenna module could be arranged above the light module, e.g. as the highest module of the lamp post.

According to an exemplary embodiment the antenna is a directional antenna. Preferably, the antenna module has a housing which is arranged in line with an axial direction of the support pole and which is rotatable around the axial direction of the support pole, such that said housing is
15 orientable for orienting the directionality of the receiving and emitting of the antenna. For example, the antenna may be included in a module as disclosed in EP 3 076 073 B1 which is included herein by reference. By using module connectors as disclosed in EP 3 076 073 B1 with two connector portions which can be clamped around round end parts of the modules, the module can be rotated around the axial direction of the support pole in the desired position and then fixed by the
20 connector portions.

According to an exemplary embodiment the base station circuitry comprises a combiner, a base transceiver unit, and a wired or wireless transmission interface configured for being connected to a communication network. The combiner is connected to the antenna and to the base transceiver
25 unit; and the base transceiver unit is further connected to the transmission interface. The transmission interface may be e.g. a fiber to copper interface. The combiner may be a dual band RF combiner. Further the base station circuitry may comprise power management circuitry to provide the required power to the combiner, the base transceiver unit and the wired or wireless transmission interface.

30

According to an exemplary embodiment the base station circuitry is configured for communicating using 2G (GSM), 2.5G (EDGE), 3G (UMTS), 4G (LTE), 5G or any other future standard.

35 According to an exemplary embodiment the housing of the base station module has an upper surface, preferably sloping downward away from the support pole, wherein a human interface device such as a display and/or a battery charger and/or a button and/or a sensor (such as a

microphone, a voice recorder, an image sensor, etc.) and/or a loudspeaker are integrated in the upper surface. The battery charger may be e.g. a wireless mobile phone charger. The display may be an interactive screen for providing information. In such embodiments the circuitry required for the battery charger and/or the display may also be provided in the housing of the base station
5 module, resulting in a multifunctional module. Further, advertising screens may be provided on the housing of the base station module.

According to a second aspect of the invention, there is provided a lamp post comprising a support pole, a light module and a functional module. The light module is supported by the support pole,
10 and comprises a light source. The functional module comprises a housing and functional circuitry mounted in said housing. The functional module is carried by the support pole, and the housing thereof comprises a frame, such as a ribbed frame; a fixing means for fixing the frame against the external surface of the support pole; and one or more panels attached to the frame, so as to enclose
15 the frame.

Preferred embodiments thereof are disclosed in the dependent claims.

The functional module may have features similar to the features of the base station module with this difference that the functional module may comprise other functional circuitry instead of or in
20 addition to base station circuitry. The technical advantages set out above for the base station module apply mutatis mutandis for the functional module.

Examples of other functional circuitry which may be included in the functional module in addition to or instead of the base station circuitry, are any one or more of the following:

25 - power management circuitry comprising e.g. one or more of: a power meter, a fuse, a line protection, a circuit breaker, an electrical connection for multiple power lines, a clock, an astroclock, a power supply module, an PLC, a computer, a communication module, display circuitry, etc.; preferably the power management circuitry is configured to manage the provision of power to one or more lamp posts, preferably at least three lamp post, e.g. more than ten lamp posts.

30 In such embodiments power connection cables pass from the functional module through the support pole to other lamp posts, e.g. underground.

- telecommunication circuitry for wired or wireless communication, which can comprise at least one of: an optical fiber connection, a fiber to copper interface, a fiber patch panel, a modem, a router, a switch, a patch panel, a network video recorder (NVR), a computer;

- audio system management circuitry which can comprise at least one of: an amplifier, a transformer, a media player (connected to network or not), electrical connections for multiple loudspeaker lines, a computer;
- WiFi circuitry, wherein an antenna for receiving WiFi signals may be integrated either in the functional module or in a separate antenna module as in the exemplary embodiment of the lamp post with a base station module;
- charger circuitry, e.g. phone/computer/tablet charger circuitry or vehicle charger circuitry or UAV charger circuitry (e.g. drone charger circuitry);
- an environmental sensor such as a sound sensor, a microphone, a voice recorder, a detector of CO₂, NO_x, smoke, or any other pollutant sensor, or an image sensor, etc., and the associated circuitry;
- a human interface device (HID) and the associated circuitry, e.g. a camera, a loudspeaker, a button, a display, etc.
- a signaling device, e.g. a light ring capable of performing signaling;
- a mechanical and/or electrical plug-in device, e.g. a universal plug-in module, e.g. a mechanical device to fix a flag, a waste bin, etc.; a socket plug-in device.

According to an exemplary embodiment, a top wall of the housing of the functional module is formed by an inclined upper surface. Preferably, said upper surface slopes downward away from the support pole. Optionally a human interface device or an advertisement device is integrated in the upper surface. The human interface device may be e.g. a display and/or a battery charger and/or a button, a display, and/or a sensor. The battery charger may be e.g. a wireless mobile phone charger. The display may be an interactive screen for providing information. In such embodiments the circuitry required for the battery charger and/or the display may also be provided in the housing of the functional module. The sensor may comprise for example any one of the following: a microphone, a detector of CO₂ and/or NO_x and/or smoke, a voice recorder, etc. The sensor may be coupled to the display such that information is displayed which is based on the sensed signals. For example, a voice recorder may record a question of a person, and an answer to the question may be presented on the display. The advertising device may be e.g. an advertising screen. Also on the peripheral wall of the housing one or more advertising screens may be provided.

In an embodiment where the housing of the functional module surrounds the support pole the inclined upper surface may be a conical or pyramid-shaped upper surface. In an embodiment with a box like housing, the upper surface may be a more or less rectangular flat inclined surface.

According to yet another aspect of the invention there is provided a lamp post comprising a support pole; a light module supported by the support pole and comprising a light source; and a first and a

second antenna module. The first and second antenna module are arranged one above the other seen in an axial direction of the support pole and are supported by the support pole. The first antenna module comprises a first housing and a first antenna, preferably a directional antenna, arranged in said first housing and configured for receiving and emitting cellular data. The second
5 antenna module comprises a second housing and a second antenna, preferably a directional antenna arranged in the second housing and configured for receiving and emitting cellular data. The first and second antenna module are rotatable around the axial direction of the support pole, such that said first and second antenna module are orientable for orienting the directionality of the receiving and emitting of the first and second antenna. The first and second antenna may be the same or
10 different.

In a preferred embodiment the lamp post further comprises a base station module comprising base station circuitry; wherein the base station circuitry is coupled to the first and second antenna. However, it is noted that according to this aspect the base station module may also be provided as a
15 separate unit or cabinet at a distance of the lamp post. In another embodiment the lamp post further comprises telecommunication circuitry, e.g. a WiFi circuitry, wherein the telecommunication circuitry is coupled to the first and second antenna.

In a preferred embodiment the first and second antenna module are arranged in a position above
20 the base station module. Preferably, the first and second antenna modules are arranged between the base station module and the light module, seen in the axial direction of the support pole. In another embodiment, the light module is arranged in a position above the first and second antenna module.

In an exemplary embodiment the light module, the first antenna module and the second antenna
25 module are arranged in variable order one above another, aligned with the support pole, wherein optionally further modules are inserted in line with the support pole.

Preferred embodiments thereof are disclosed in the dependent claims. Such embodiments may include a base station module with the same technical advantages as disclosed above for the first
30 aspect.

In typical embodiments the support pole may be fixed in the ground, and a bottom wall of the functional module, such as the base station module, will be at a distance from the ground. In such cases the support pole is typically oriented substantially vertically. In other embodiments the
35 support pole may be fixed in a wall and may extend at least partly horizontally or at an angle. In

both embodiments the bottom wall may be floating with an air path present underneath the bottom wall.

It is noted that the support pole may be one integral pole, e.g. a metal pole, or may consist of one
5 or more modules arranged one above the other in order to form a pole like structure.

According to an exemplary embodiment, the housing of the functional module, such as the base station module, comprises at least one panel in the form of a side door for providing access to an internal space of the housing. In that manner operators can access the functional circuitry, such as
10 the base station circuitry, easily. The peripheral wall of the housing may comprise at least two side doors for providing access to an internal space of the housing. Using multiple doors may facilitate the mounting of and/or access to the functional circuitry and/or may allow different operators to have access to different parts of the housing.

One or more upper ventilation holes may be provided in the at least one side door and/or in other
15 portions of the peripheral wall. One or each side door may be provided with a locking device, preferably a three-point locking device. In that manner the functional module can be made vandalism-proof. Further features may be added to increase the resistance against vandalism, such as the provision of an edge on the inside of the housing, said edge bridging a gap between a closed door and an opening in the peripheral wall. In that manner it can be avoided that the door is forced
20 by inserting a thin flat tool in the gap. Preferably, the one or more side doors are fixed to the rest of the housing using hinges fixed to an internal portion of the housing, so that the hinges are not accessible from the exterior of the housing.

According to an exemplary embodiment the housing of the functional module, such as the base station module, is provided with at least one separation wall dividing an internal space of the
25 housing into at least two compartments. The at least two compartments may be accessible by at least two side doors included in the housing. The at least two compartments may comprise a first and a second compartment separated by a vertical separation wall and the at least two side doors may comprise a first door and a second door providing access to the first and second compartment,
30 respectively. The vertical separation wall may be extending from the support pole outwardly, e.g. in a radial plane, creating a first and second compartment on opposite sides thereof. In such embodiments, the first door and the second door may form opposite wall portions of the peripheral wall. In other embodiments the vertical separation wall may extend at a distance of the support pole creating two adjacent compartments, one closer to the support pole and one further away from
35 the support pole. The first door and the second door may then form adjacent wall portions of the peripheral wall. The second door may be located at the same side of the housing as the first door,

or the first and second door may be located on opposite sides of the housing. In such embodiments the vertical separation wall may be provided with one or more air flow holes to allow the passage of air from the second compartment to the first compartment. The skilled person understands that also various combinations with more than two compartments are possible, e.g. in an embodiment
5 with one radial separation wall and a further separation wall on each side of the radial separation wall, four compartments may be present.

In addition or alternatively, the at least two compartments may comprise a first and a second compartment separated by a horizontal separation wall. In such an embodiment the at least two side doors may comprise a first door and a second door providing access to the first and second
10 compartment, respectively, said second door being located below said first door. The second door may be located at the same side of the housing or on opposite sides of the housing. In such embodiments the horizontal separation wall may be provided with one or more air flow holes to allow the passage of air from the second compartment to the first compartment located above the second compartment. The upper air flow holes are then preferably provided in a wall portion of the
15 peripheral wall delimiting the first compartment and/or in a portion of the support pole delimiting the first compartment.

According to an exemplary embodiment, at least one fixation plate is provided in the housing of the functional module, such as the base station module, wherein the functional circuitry is fixed at
20 least partly against the fixation plate. For example two fixation plates may be provided at a distance of each other in an opening of a peripheral wall of the housing, wherein the opening is closable by a door. The or each fixation plate may be provided with a plurality of fixation holes for cooperating with fixation means. The use of one or more fixation plates not only increases the rigidity of the functional module but also makes the installation and/or maintenance of the
25 functional circuitry easier.

According to an exemplary embodiment, a fan is arranged in the housing of the functional module, and/or in the support pole. The fan is preferably arranged to increase the air flow through the functional module. Preferably the fan is arranged in the housing, e.g. in an upper or lower portion
30 of the housing. If multiple compartments are present, there may be provided one fan in one of the compartments (with one or more air flow holes provided in the separation wall(s)), or there may be provided multiple fans in different compartments.

Brief description of the figures

35 The accompanying drawings are used to illustrate presently preferred non-limiting exemplary embodiments of devices of the present invention. The above and other advantages of the features

and objects of the invention will become more apparent and the invention will be better understood from the following detailed description when read in conjunction with the accompanying drawings, in which:

Figure 1 illustrates schematically an exemplary embodiment of a lamp post of the invention;

5 Figure 2 is a schematic perspective view of an exemplary embodiment of a base station module fixed to a support module of a lamp post; Figure 2A is a detailed view of a portion of Figure 2; Figure 3 is a schematic perspective view of an exemplary embodiment of a base station module without the panels of the housing and without the base station circuitry, to visualize the ribbed frame;

10 Figure 4 is a schematic perspective view of an exemplary embodiment of a base station module without the panels of the housing but with the base station circuitry;

Figure 5 is a schematic perspective view of an exemplary embodiment of a base station module with one panel of the housing, but without the side panels and without the base station circuitry;

Figure 6 is a schematic perspective view of an exemplary embodiment of an antenna module;

15 Figure 7 illustrates schematically another exemplary embodiment of a lamp post of the invention; Figure 8 and 9 illustrate schematic perspective views of two other exemplary embodiments of a functional module for a lamp post;

Figure 10 illustrates schematically a top view of an exemplary embodiment of a functional module; and

20 Figures 11A-11C illustrate schematically possible door combinations of a functional module according to exemplary embodiments.

Description of embodiments

Figure 1 illustrates schematically an exemplary embodiment of a lamp post 1000. The lamp post
25 1000 comprises a support pole 100 and a plurality of modules 200, 300, 400, 600 supported by the support pole 100. The plurality of modules comprises a light module 200 comprising a light source, an antenna module 300 comprising an antenna 350 configured for receiving and emitting cellular data; and an optional further module 400, e.g. a Wi-Fi transceiver module, a loudspeaker module, a camera module, a video surveillance module, etc. Other examples functionalities which
30 may be included in one or more modules 400 are any one or more of the following:

- power management circuitry comprising e.g. one or more of: a power meter, a fuse, a line protection, a circuit breaker, an electrical connection for multiple power lines, a clock, an astroclock, a power supply module, an PLC, a computer, a communication module, display circuitry, etc.; preferably the power management circuitry is configured to manage the provision of
35 power to one or more lamp posts, preferably at least three lamp post, e.g. more than ten lamp posts.

In such embodiments power connection cables pass from the functional module through the support pole to other lamp posts, e.g. underground.

- telecommunication circuitry for wired or wireless communication, which can comprise at least one of: an optical fiber connection, a fiber to copper interface, a fiber patch panel, a modem, a router, a switch, a patch panel, a network video recorder (NVR), a computer;
 - audio system management circuitry which can comprise at least one of: an amplifier, a transformer, a media player (connected to network or not), electrical connections for multiple loudspeaker lines, a computer;
 - WiFi circuitry;
 - charger circuitry, e.g. phone/computer/tablet charger circuitry or vehicle charger circuitry or UAV charger circuitry (e.g. drone charger circuitry);
 - an environmental sensor such as a sound sensor, a microphone, a voice recorder, or a detector of CO₂, NO_x, smoke, or any other pollutant sensor, or an image sensor, etc., and the associated circuitry;
 - any human interface device (HID) and the associated circuitry;
 - a signaling device, e.g. a light ring capable of performing signaling;
 - a mechanical and/or electrical plug-in device, e.g. a universal plug-in module, e.g. a mechanical device to fix a flag, a waste bin, etc.; a socket plug-in device.
- The modules 200, 300, 400 may be arranged in any order one above the other, and may be connected to the support pole 100 and to each other in any suitable way, e.g. using connectors 510, 520, 530 as described in EP 3 076 073 B1 in the name of the applicant.

The plurality of modules further comprises a base station module 600 comprising a housing 610 and base station circuitry 621, 622, 623, 624 mounted in said housing 610, see also figure 2 and 4. The base station circuitry 621, 622, 623, 624 is coupled to the antenna 350, see reference 710. The base station module 600 is attached to an external surface 110 of the support pole 100 and the weight thereof is carried by the support pole 100. As illustrated in figure 2, the support pole 100 may be fixed in the ground G and the housing of the base station module 600 may be at a distance d above the ground G. However, it is also possible to arrange the base station module more or less flush with the ground G.

The housing 610 of the base station module 600 comprises a structurally rigid ribbed frame 630 attached to the support pole 100; a fixing means 691, 692, e.g. at least two screws or bolts, for fixing the ribbed frame 630 against the external surface 110 of the support pole 100; and one or more panels 661, 662, 663 attached to the ribbed frame, so as to enclose the ribbed frame; see

figures 2-5. According to an exemplary embodiment, the housing 610 may be provided with one or more ventilation openings, e.g. a plurality of slits or holes. In the illustrated embodiment a plurality of slits 615a, 615b is arranged in the two opposite side panels 662, 663 of the housing, such that an air flow through the housing is created.

5

The ribbed frame 630 may comprises at least four upright girders 631, 632, 633, 634; at least four side girders 651, 652, 653, 654 extending in a first width direction perpendicular to an axial direction A of the support pole and connecting the four upright girders 631, 632, 633, 634; and at least four side girders 635, 636, 637, 638 extending in a plane perpendicular to the first width direction and connecting the four upright girders 631, 632, 633, 634. Optionally additional side girders 639, 640, 641 may be provided to facilitate the fixing of the base station circuitry. The ribbed frame 630 is attached to the support pole 100 at a first and second position being at a distance of each other seen in an axial direction of the support pole 100, using e.g. a first and second screw or bolt 691, 692 which passes through girders 642, 643. Optionally additional attachment positions may be provided to facilitate the attaching of the ribbed frame 630 to the support pole 100. In the illustrated embodiment the panels include two side panels 662, 663 and a central angled panel 661 intended to form the top and front side of the housing 610. The central panel 661 may be provided with edges 665 extending over the edges of the side panels 662, 663, as illustrated in figure 2A. Optionally a seal (not shown) may be arranged between the edges of adjacent panels. In that manner the risk that water and/or dirt enters in the housing 610 between the edges of the panels, is limited. The skilled person understands that the enclosure of the housing 610 may be formed by other ways, e.g. one integrated enclosure which can be placed around and fixed to the ribbed frame.

10

15

20

25

The support pole 100 is hollow, and is provided with a removable door 120 providing access to an inner part of said support pole 100, see figure 1. The door 120 is arranged substantially opposite to the base station module 600, so that an operator can access the interior of the base station module 600 through the door 120. However, it is also possible to remove one or more panels 661, 662, 663 of the housing 610, in order to access the base station circuitry 621, 622, 623, 624.

30

The housing 610 of the base station module 600 covers a surface area of the support pole 100; and the support pole 100 is provided in said surface area with a first hole 131 and a second hole 132 positioned above the first hole 131 seen in an axial direction of the support pole 100, see figure 3 and 4. The lamp post 1000 comprises a connection cable 710 (see figure 1, not shown in figures 3 and 4) from the antenna 350 through an inner part of the support pole 100, through the second hole 132 to the base station circuitry 621, 622, 623, 624; and a power connection cable 720 passing

35

from a lower end of the support pole 100 through the first hole 131 to feed the base station circuitry 621, 622, 623, 624.

5 The housing 610 of the base station module 600 has a first width w_1 extending in a first direction perpendicular to an axial direction A of the support pole 100, said first width w_1 being inferior to an external diameter D of the support pole 100. The housing of the base station module 600 has a second width w_2 extending in a second direction perpendicular to the first width and to the axial direction A of the support pole 100, said second width w_2 being superior to an external diameter of the support pole 100, preferably at least twice the external diameter of the support pole 100. In that
10 manner a relatively long and narrow compact casing 600 is obtained with a suitable shape for holding base station circuitry.

The antenna module 300 is arranged in a position above the base station module 600. The antenna module 300 is arranged between the base station module 600 and the light module 200, seen in an
15 axial direction of the support pole 100. In an alternative embodiment the antenna module 300 could be arranged above the light module 200. The antenna 350 may be a directional antenna with a limited angular range, e.g. a range covering between 90° and 180° . The antenna module 300 has a housing 310, 320 which is arranged in line with the support pole 100. Preferably, the antenna module 300 is rotatable around an axis A of the support pole 100, such that said antenna module
20 300 is orientable for orienting the directionality of the receiving and emitting of the antenna 350. For example, the antenna may be included in a module as disclosed in EP 3 076 073 B1 which is included herein by reference. Such an example is illustrated in figure 6. By using module connectors 510, 520, 530 (see figure 1 and 6, wherein only connector 530 is shown in figure 6) with two connector portions 530a, 530b which can be clamped around round end parts 331, 332 of
25 the modules, the module 300 can be rotated around the axial direction A of the support pole 100 in a desired position and then fixed by the connector portions 530a, 530b. The antenna module 300 may comprise a central portion 330 including a passage for cables and wires and two cover portions 310, 320. The antenna 350 may be arranged against a face of the central portion 330 and covered by a first cover 310 in a non-metallic material e.g. a plastic material. The central portion
30 330 and the second cover 320 may be made of a metallic material to enhance the rigidity of the antenna module 300. Module 200' shown in figure 6 may be a light module or another additional module, e.g. a Wi-Fi transceiver module, a loudspeaker module, a camera module, a video surveillance module, etc.

35 As shown in figure 4 the base station circuitry comprises a combiner 622, a base transceiver unit 621; a wired or wireless transmission interface 623 configured for being connected to a

communication network; and a power management unit 624. The combiner 622 is connected to the antenna 350 and to the base transceiver unit 621; and the base transceiver unit 621 is further connected to the transmission interface 623. The transmission interface 623 may be e.g. a fibre to copper interface.

5

In the illustrated embodiment of figures 2 and 5 the housing 610 of the base station module 600 has an inclined upper surface 671, said upper surface sloping downward away from the support pole 100, wherein a display 680 and/or a battery charger and/or a sensor and/or a button and/or any other human interface devices (see also the examples given below) may be integrated in the inclined upper surface 671. In other embodiments the upper surface 671 may be a horizontal surface or a curved surface.

10

In the exemplary embodiments described above module 600 is a base station module. However, this module 600 may also be used to house different circuitry in addition to or instead of base station circuitry. Examples of other functional circuitry which may be included in the functional module in addition to or instead of the base station circuitry, are any one or more of the following:

15 - power management circuitry comprising e.g. one or more of: a power meter, a fuse, a line protection, a circuit breaker, an electrical connection for multiple power lines, a clock, an astroclock, a power supply module, an PLC, a computer, a communication module, display circuitry, etc.; preferably the power management circuitry is configured to manage the provision of power to one or more lamp posts, preferably at least three lamp post, e.g. more than ten lamp posts. In such embodiments power connection cables pass from the functional module through the support pole to other lamp posts, e.g. underground.

15

20

- telecommunication circuitry for wired or wireless communication, which can comprise at least one of: an optical fiber connection, a fiber to copper interface, a fiber patch panel, a modem, a router, a switch, a patch panel, a network video recorder (NVR), a computer;

25

- audio system management circuitry which can comprise at least one of: an amplifier, a transformer, a media player (connected to network or not), electrical connections for multiple loudspeaker lines, a computer;

30

- WiFi circuitry, wherein an antenna for receiving WiFi signals may be integrated either in the functional module or in a separate antenna module as in the exemplary embodiment of the lamp post with a base station module;

- charger circuitry, e.g. phone/computer/tablet charger circuitry or vehicle charger circuitry or UAV charger circuitry (e.g. drone charger circuitry);

- an environmental sensor such as a sound sensor, a microphone, a voice recorder, or a detector of CO₂, NO_x, smoke, or any other pollutant sensor, or an image sensor, etc., and the associated circuitry;
- a human interface device (HID) and the associated circuitry, e.g. a camera, a loudspeaker, a button, a display, etc.;
- a signaling device, e.g. a light ring capable of performing signaling;
- a mechanical and/or electrical plug-in device, e.g. a universal plug-in module, e.g. a mechanical device to fix a flag, a waste bin, etc.; a socket plug-in device.

10 Figure 7 illustrates schematically an exemplary embodiment with two antenna modules. The lamp post comprises a support pole 100; a light module 200 comprising a light source; and a first and a second antenna module 300, 300'. The first and a second antenna module 300, 300' are arranged one above the other seen in an axial direction of the support pole 100 and are supported by the support pole 100. The first antenna module 300 comprises a first housing and a first directional
15 antenna 350 arranged in said first housing and configured for receiving and emitting cellular data. The first antenna module 300 may be implemented e.g. as described above referring to figure 6. The second antenna module 300' may be the same or similar to the first antenna module 300, and comprises a second housing and a second directional antenna 350' arranged in said second housing and configured for receiving and emitting cellular data. The first and second antenna module 300,
20 300' are rotatable around the axial direction A of the support pole 100, such that said first and second antenna module 300, 300' are orientable for orienting the directionality of the receiving and emitting of the first and second directional antenna. The light module 200, the first antenna module 300 and the second antenna module 300 may be arranged in variable order one above another, aligned with the support pole 100, wherein optionally further modules are inserted in line with the
25 support pole 100. Optionally, the lamp post 100 further comprises a functional module, such as a base station module (not shown) comprising base station circuitry; wherein the base station circuitry is coupled to the first and second directional antenna 350, 350'. Preferably the first and second antenna module 300, 300' are arranged in a position above the base station module. The first and second antenna module 300, 300' may be arranged between the base station module and
30 the light module 200', seen in the axial direction of the support pole 100. The base station module may be implemented according to any one of the embodiments described above.

It is further noted that in embodiments of the invention base station functionalities and/or other functionalities may be either included in a module like base station module 600 fixed to the support
35 pole, or in one or more modules 400 supported by the support pole 100 and aligned with the axial

direction of the support pole 100. To that end the module 400 may have a larger diameter than the diameter of the support pole 100.

5 The base station module of the embodiment of the figures may be replaced with a similar functional module comprising other functional circuitry instead of or in addition to base station circuitry. The technical advantages set out above for the base station module apply *mutatis mutandis* for the functional module.

10 Figures 8 and 9 illustrate that multiple functional modules 600, 600' may be added to a single support pole. In the example of figure 8, two rather narrow ($w_1 < D$) functional modules 600, 600' are arranged on opposite sides of the support pole 100. Depending on the available space the functional modules 600, 600' may be aligned with each other or may be at an angle. The functional modules 600, 600' may have a similar or identical housing, but may contain different functional circuitry. In the example of figure 9 two functional modules 600, 600' are attached one above the
15 other to the support pole 100. In such a configuration the top wall of the lower functional module 600' may be omitted. The skilled person understands that also more than two functional modules 600, 600' may be attached to and supported by the support pole 100 depending on the size and requirements of the lamp post.

20 As illustrated in the top view of figure 10 the housing 610 of a functional module may be provided with a separation wall 607 dividing the internal space of the housing 610 into two compartments 610a, 610b. However, the housing 610 may also comprise only one compartment as illustrated in figure 1. In figure 10, the two compartments comprise a first and a second compartment 610a, 610b separated by a vertical separation wall 607, and a first door 603a and a second door 603b
25 provide access to the first and second compartment 610a, 610b, respectively. The vertical separation wall 607 extends from the support pole outwardly, here in a radial plane, creating the first and second compartment 610a, 610b on opposite sides thereof. In figure 1, one compartment is accessible from two sides through the two side doors 603a, 603b. Alternatively there may be provided only one side door 603a. In figure 10, the first door and the second door 603a, 603b form
30 opposite wall portions of a peripheral wall.

In other embodiments, illustrated in figures 11A-11C, a first door and second door 603a, 603a' form adjacent wall portions of the peripheral wall.

35 In figure 11A a first and a second compartment 610a, 610a' are separated by a horizontal separation wall 608 and the first and second door 603a, 603a' provide access to the first and second compartment 610a, 610a', respectively. The second door 603a' is located below the first door

603a. The housing is provided with one or more ventilation openings, e.g. a plurality of slits or holes. In the illustrated embodiment a plurality of slits 613a, 613b is arranged in the two opposite side doors 603a, 603b of the peripheral wall of the housing, and a plurality of lower air flow holes 611 is provided in the bottom wall 601, such that an upward air flow through the housing is created. The horizontal separation wall 608 may be provided with one or more air flow holes 618 to allow the passage of air from the second compartment 610a' to the first compartment 610. The upper air flow holes 613a, 613b are then preferably provided in a wall portion of the peripheral wall delimiting the first and second compartment 610a, 610a' and/or in a portion of the support pole delimiting the first compartment 610a. For example, as shown, upper air flow holes 613a may be provided in an upper portion of the first door 603a which is part of the peripheral wall. Optionally a vertical separation wall (not shown in figure 11A) may be provided, as in the embodiment of figure 10. Such a vertical separation wall may be provided in one or in both of the first and second compartments 610a, 610a'.

In figure 11B the vertical separation wall 607' extends at a distance of the support pole creating two adjacent compartments 610a, 610a', one closer to the support pole 100 and one further away from the support pole 100. The first door and the second door 603a, 603b may then form adjacent wall portions of the peripheral wall. The separation wall 607' may be provided with one or more air flow holes 617' to allow the passage of air from the second compartment 610a' to the first compartment 610. One or more upper air flow holes 613' are then preferably provided in a wall portion of the peripheral wall delimiting the compartments 610a, 610a' and/or in a portion of the support pole delimiting the first compartment 610a. For example, upper air flow holes (not shown) may be provided in upper portions of the first and second door 603a, 603a' which are part of the peripheral wall.

The skilled person understands that also various combinations with more than two compartments are possible. For example in figure 11C one radial separation wall 607 is provided with four smaller compartments 610a, 610a', 610a'', 610a''' on one side and one bigger compartment 610b on the other side. The four smaller compartments 610a, 610a', 610a'', 610a''' are separated from one another by a further vertical separation wall 607' and two horizontal separation walls 608, 608'. The four smaller compartments 610a, 610a', 610a'', 610a''' are accessible through separate side doors 603a, 603a', 603a'', 603a''', respectively. The bigger compartment 610b is accessible through a bigger side door 603b. The horizontal separation walls 608, 608' may be provided with one or more air flow holes 618, 618' to allow the passage of air from the compartments 610a'', 610a''' to the compartments 610a, 610a'. The upper air flow holes (not shown) may be provided in

a wall portion of the peripheral wall delimiting the compartments 610a, 610a', 610a'', 610a''', 610b and/or in a portion of the support pole 100 delimiting the compartments 610a, 610a'', 610b.

5 Whilst the principles of the invention have been set out above in connection with specific embodiments, it is to be understood that this description is merely made by way of example and not as a limitation of the scope of protection which is determined by the appended claims.

Claims

1. A lamp post (1000) comprising:
 - a support pole (100);
 - 5 – a light module (200) supported by the support pole (100); said light module (200) comprising a light source;
 - an antenna module (300) supported by the support pole (100); said antenna module (300) comprising an antenna (350) configured for receiving and emitting cellular data; and
 - 10 – a base station module (600); wherein the base station module (600) comprises a housing (610) and base station circuitry (621, 622, 623, 624) mounted in said housing (610); wherein the base station circuitry is coupled to the antenna (350); wherein the base station module (600) is attached to an external surface (110) of the support pole (100) and carried by the support pole (100).
 - 15
2. The lamp post of claim 1, wherein the support pole (100) is fixed in the ground G and the housing of the base station module (600) is at a distance d above the ground G.
3. The lamp post according to any preceding claim, wherein the housing (610) of the base station module (600) comprises a structurally rigid ribbed frame (630) attached to the support pole (100); a fixing means (691, 692) for fixing the ribbed frame (630) against an external surface (110) of the support pole (100); one or more panels (661, 662, 663) attached to the ribbed frame, so as to enclose the ribbed frame (630).
- 20
4. The lamp post according to any preceding claim, wherein the ribbed frame (630) is attached to the support pole (100) at a first and second position being at a distance of each other seen in an axial direction of the support pole (100).
- 25
5. The lamp post according to any preceding claim, wherein the support pole (100) is hollow, and wherein the support pole (100) is provided with a removable door (120) providing access to an inner part of said support pole (100), wherein said door (120) is arranged substantially opposite to the base station module (600).
- 30
6. The lamp post according to any preceding claim, wherein the housing (610) of the base station module (600) covers a surface area of the support pole (100); wherein the support pole (100) is provided in said surface area with a first hole (131) and a second hole (132) positioned above the first hole seen in an axial direction of the support pole (100); wherein
- 35

the lamp post comprises a connection cable from the antenna through an inner part of the support pole (100), through the second hole to the base station circuitry; and a power connection cable passing from a lower end of the support pole (100) through the first hole to feed the base station circuitry.

5

7. The lamp post according to any preceding claim, wherein the housing (610) of the base station module (600) has a first width w_1 extending in a first direction perpendicular to an axial direction A of the support pole (100), said first width w_1 being inferior to an external diameter D of the support pole (100).

10

8. The lamp post according to the preceding claim, wherein the housing of the base station module (600) has a second width w_2 extending in a second direction perpendicular to the first width and to the axial direction A of the support pole (100), said second width being superior to an external diameter of the support pole (100), preferably at least twice the external diameter of the support pole (100).

15

9. The lamp post according to any preceding claim, wherein the antenna module (300) is arranged in a position above the base station module (600).

20

10. The lamp post according to any preceding claim, wherein the antenna module (300) is arranged between the base station module (600) and the light module (200), seen in an axial direction of the support pole (100).

25

11. The lamp post according to any preceding claim, wherein the antenna (350) is a directional antenna.

30

12. The lamp post according to any preceding claim, wherein the antenna module (300) has a housing (310, 320) which is arranged in line with the support pole (100); wherein the antenna module (300) is rotatable around an axis A of the support pole (100), such that said antenna module (300) is orientable for orienting the directionality of the receiving and emitting of the antenna (350).

35

13. The lamp post according to any preceding claim, wherein the base station circuitry comprises a combiner (622), a base transceiver unit (621) and a wired or wireless transmission interface (623) configured for being connected to a communication network; wherein the combiner (622) is connected to the antenna (350) and to the base transceiver unit (621); and wherein the base transceiver unit (621) is further connected to the transmission interface (623).

14. The lamp post according to the preceding claim, wherein the transmission interface (623) is a fiber to copper interface.
- 5 15. The lamp post according to any preceding claim, wherein the housing (610) of the base station module (600) has an upper surface, preferably an inclined upper surface (671) sloping downward away from the support pole (100), wherein a human interface device, such as a display (680) and/or a charger, and/or a sensor, and/or a button is integrated in the upper surface.
- 10 16. The lamp post according to any preceding claim, wherein the housing (610) of the base station module (600) is provided with one or more ventilation openings (615a, 615b).
17. A lamp post comprising:
- 15 – a support pole (100);
- a light module (200) supported by the support pole (100); said light module (200) comprising a light source;
- a functional module; wherein the functional module comprises a housing and functional circuitry mounted in said housing; wherein the functional module is
- 20 carried by the support pole (100); wherein said housing comprises a ribbed frame; a fixing means for fixing the ribbed frame against the external surface of the support pole (100); and one or more panels attached to the ribbed frame, so as to enclose the ribbed frame.
- 25 18. The lamp post of claim 17, wherein the support pole (100) is fixed in the ground G and the housing of the functional module is at a distance d of the ground G.
19. The lamp post according to claim 17 or 18, wherein the ribbed frame is attached to the support pole (100) at a first and second position being at a distance of each other seen in an
- 30 axial direction of the support pole (100).
20. The lamp post according to any one of the claims 17-19, wherein the support pole (100) is hollow, and wherein the support pole (100) is provided with a removable door providing access to an inner part of said support pole (100), wherein said door is arranged
- 35 substantially opposite to the functional module.
21. The lamp post according to any one of the claims 17-20, wherein the housing of the functional module has a first width extending in a first direction perpendicular to an axial

direction of the support pole (100), said first width being inferior to an external diameter of the support pole (100).

5 22. The lamp post according to the preceding claim, wherein the housing of the functional module has a second width extending in a second direction perpendicular to the first width and to an axial direction of the support pole (100), said second width being superior to an external diameter of the support pole (100), preferably at least twice the external diameter of the support pole (100).

10 23. The lamp post according to any one of the claims 17-22, wherein the housing of the functional module has an upper surface, preferably an inclined upper surface sloping downward away from the support pole (100), wherein a human interface device is integrated in the upper surface.

15 24. The lamp post according to any one of the claims 17-23, wherein the functional circuitry comprises at least one of:

- power management circuitry preferably configured to manage the provision of power to one or more lamp posts;
- telecommunication circuitry;
- 20 – audio system management circuitry;
- WiFi circuitry;
- charger circuitry;
- an environmental sensor and the associated circuitry;
- a human interface device (HID) and the associated circuitry, such as a camera, a loudspeaker, a button, a display;
- 25 – a signaling device;
- a plug-in device.

30 25. The lamp post according to any preceding claim, wherein a peripheral wall of the housing comprises at least one side door for providing access to an internal space of the housing, preferably at least two side doors for providing access to an internal space of the housing.

35 26. The lamp post according to the preceding claim, wherein one or each side door is provided with a locking device, preferably a three-point locking device.

27. The lamp post according to any preceding claim, wherein the housing is provided with at least one separation wall dividing the internal space of the housing into at least two compartments.
- 5 28. The lamp post according to claim 25 and 27, wherein the at least two compartments are accessible by the at least two side doors.
29. The lamp post according to claim 28, wherein the at least two compartments comprise a first and a second compartment separated by a horizontal separation wall and wherein the
10 at least two side doors comprise a first door and a second door providing access to the first and second compartment, respectively, said second door being located below said first door.
30. The lamp post according to claim 28 or 29, wherein the at least two compartments
15 comprise a first and a second compartment separated by a vertical separation wall and wherein the at least two side doors comprise a first door and a second door providing access to the first and second compartment, respectively.
31. The lamp post according to claim 29 or 30, wherein the first door and the second door
20 form opposite wall portions of the housing.
32. The lamp post according to claim 29 or 30, wherein the first door and the second door form adjacent wall portions of the housing.
- 25 33. The lamp post according to any preceding claim, wherein the housing comprises a bottom wall intended to be floating, a top wall and a peripheral wall between the bottom and top wall, said housing covering or surrounding a portion of the support pole; wherein the bottom wall is provided with one or more lower air flow holes; and wherein at least one of the peripheral wall and said portion of the support pole, is provided with one or more
30 upper air flow holes.
34. A lamp post comprising:
- a support pole (100);
 - a light module (200) supported by the support pole (100); said light module (200)
35 comprising a light source;
 - a first and a second antenna module (300, 300') which are arranged one above the other seen in an axial direction of the support pole (100) and which are supported by the support pole (100); said first antenna module (300) comprising a first

housing and a first directional antenna (350) arranged in said first housing and configured for receiving and emitting cellular data; said second antenna module (300') comprising a second housing and a second directional antenna (350') arranged in said second housing and configured for receiving and emitting cellular data; said first and second antenna module being rotatable around the axial direction of the support pole (100), such that said first and second antenna module are orientable for orienting the directionality of the receiving and emitting of the first and second directional antenna (350, 350').

- 5
- 10 35. The lamp post according to the preceding claim, wherein the light module (200), the first antenna module (300) and the second antenna module (300) are arranged in variable order one above another, aligned with the support pole (100), wherein optionally further modules are inserted in line with the support pole (100).
- 15 36. The lamp post according to claim 34 or 35, wherein the first and second housing each comprises a central portion (330) including a passage for cables and wires a first non-metallic cover portion (310) and a second cover portion (320), said first and second cover portion surrounding the central portion (330), wherein the first/second antenna is arranged between the first cover portion and the central portion.
- 20 37. The lamp post according to the preceding claim, wherein the central portion (330) and the second cover (320) are made of a metallic material.
- 25 38. The lamp post according to any one of the claims 34-38, further comprising a base station module (600) comprising base station circuitry; wherein the base station circuitry is coupled to the first and second directional antenna; wherein preferably the first and second antenna module (300) are arranged in a position above the base station module (600).
- 30 39. The lamp post according to the preceding claim, wherein the first and second antenna module (300) are arranged between the base station module (600) and the light module (200), seen in the axial direction of the support pole (100).
- 35 40. The lamp post according to any one of the claims 38-39, wherein the base station module (600) has a housing with an upper surface, said upper surface preferably sloping downward away from the support pole (100), wherein a human interface device is integrated in the upper surface.

41. The lamp post according to any one of the claims 38-40, wherein the base station module (600) is attached to an external surface of the support pole (100) and carried by the support pole (100); wherein preferably the support pole (100) is fixed in the ground G and the housing of the base station module (600) is at a distance d of the ground G.
- 5
42. The lamp post according to any one of the claims 38-41, wherein the base station module (600) has a housing covering a surface area of the support pole (100); wherein the support pole (100) is provided in said surface area with a first hole and a second hole positioned above the first hole seen in an axial direction of the support pole (100); wherein the lamp post comprises a first and a second connection cable from the first and the second directional antenna through an inner part of the support pole (100), through the second hole to the base station circuitry; and a power connection cable passing from a lower end of the support pole (100) through the first hole to feed the base station circuitry.
- 10
43. The lamp post according to any one of the claims 38-42, wherein the base station circuitry comprises a combiner, a base transceiver unit and a wired or wireless transmission interface configured for being connected to a communication network; wherein the combiner is connected to the antenna and to the base transceiver unit; and wherein the base transceiver unit is further connected to the transmission interface.
- 15
44. The lamp post according to the preceding claim, wherein the transmission interface is a fiber to copper interface.
- 20
45. The lamp post according to any one of the claims 38-43, wherein the base station module (600) has a housing provided with one or more ventilation openings (615a, 615b).
- 25
46. The lamp post according to any preceding claim, wherein the light source comprises a plurality of light emitting diodes, and a driver for driving the plurality of light emitting diodes.

1/10

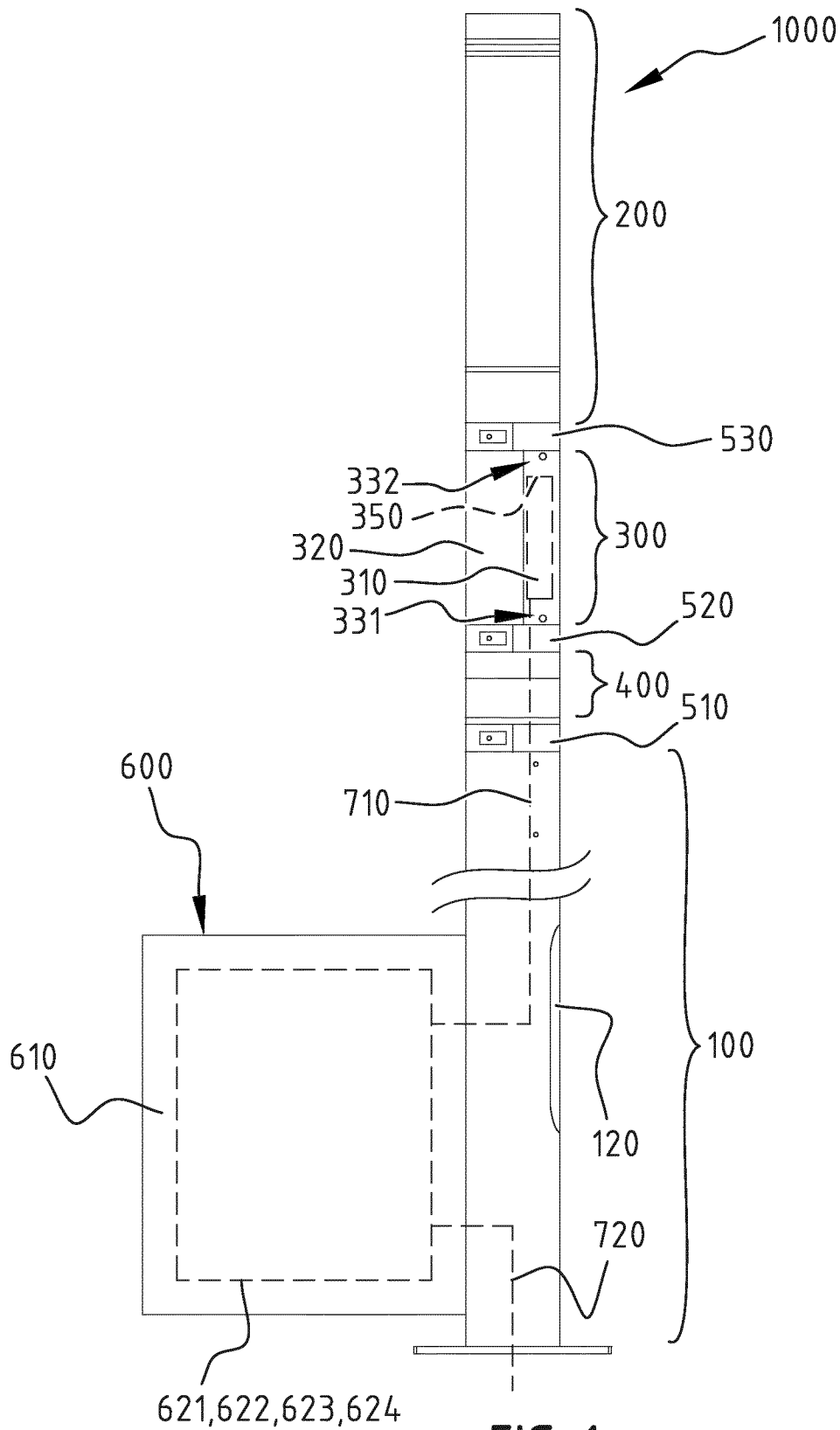
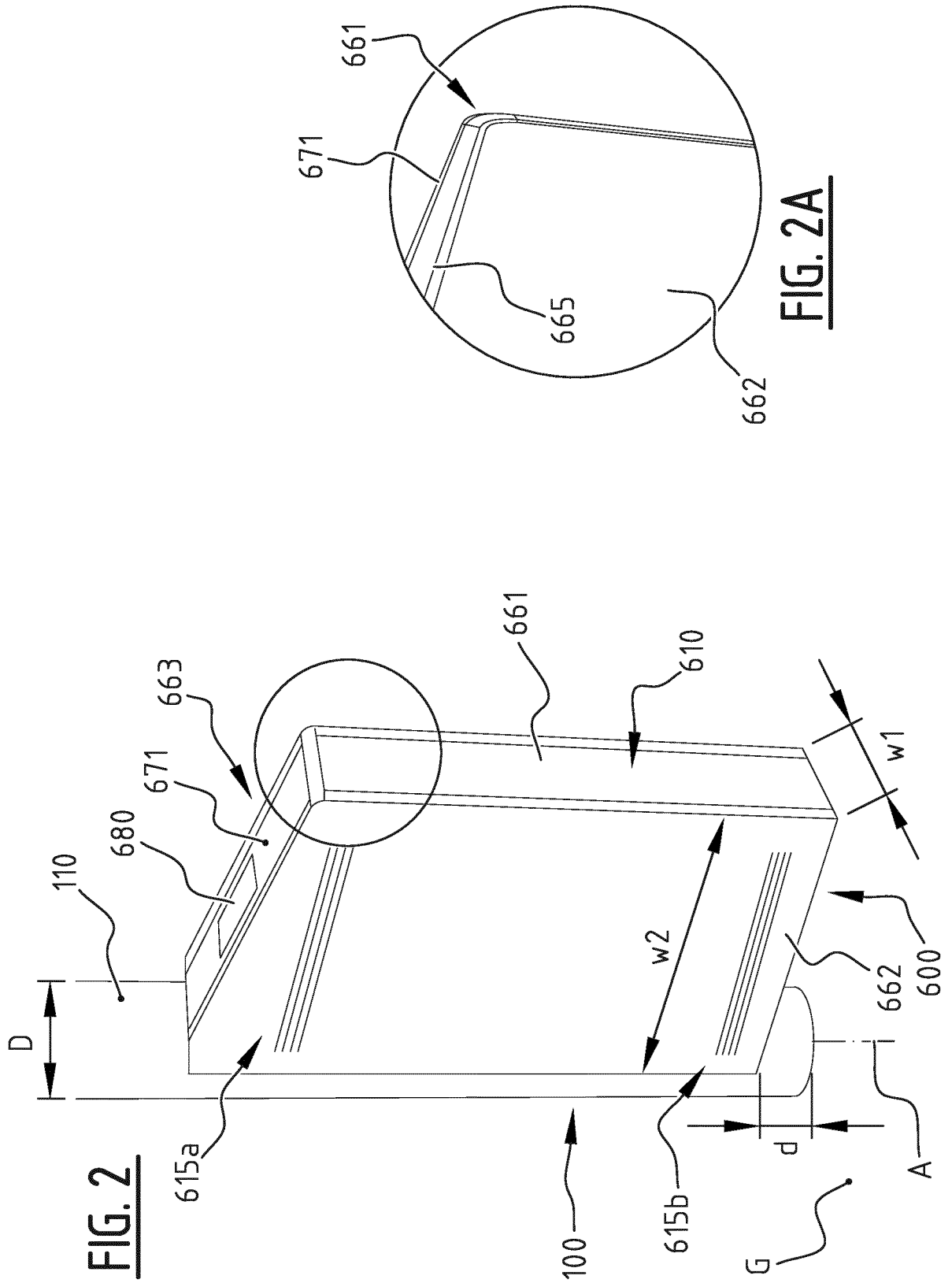

FIG. 1



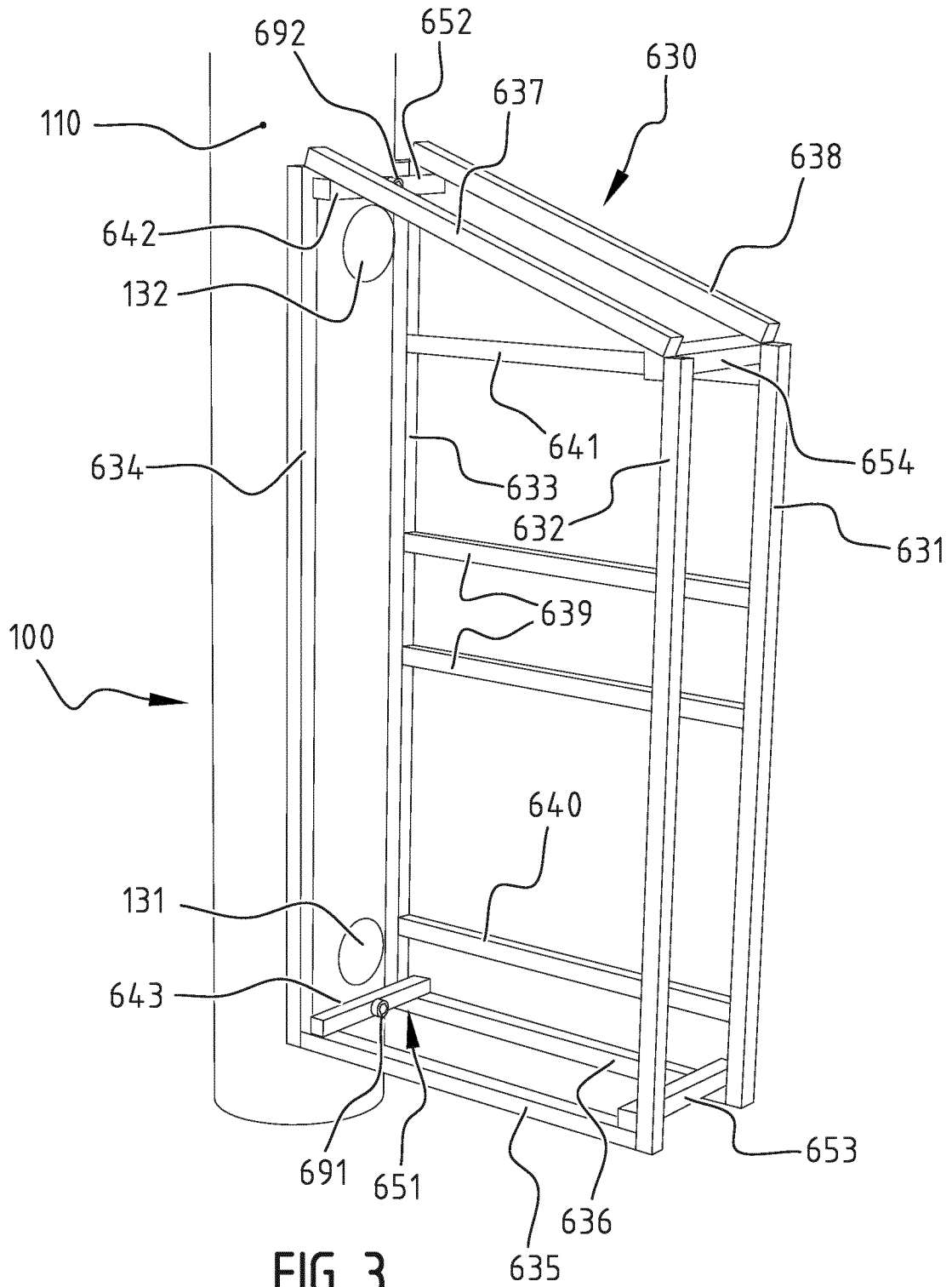

FIG. 3

4/10

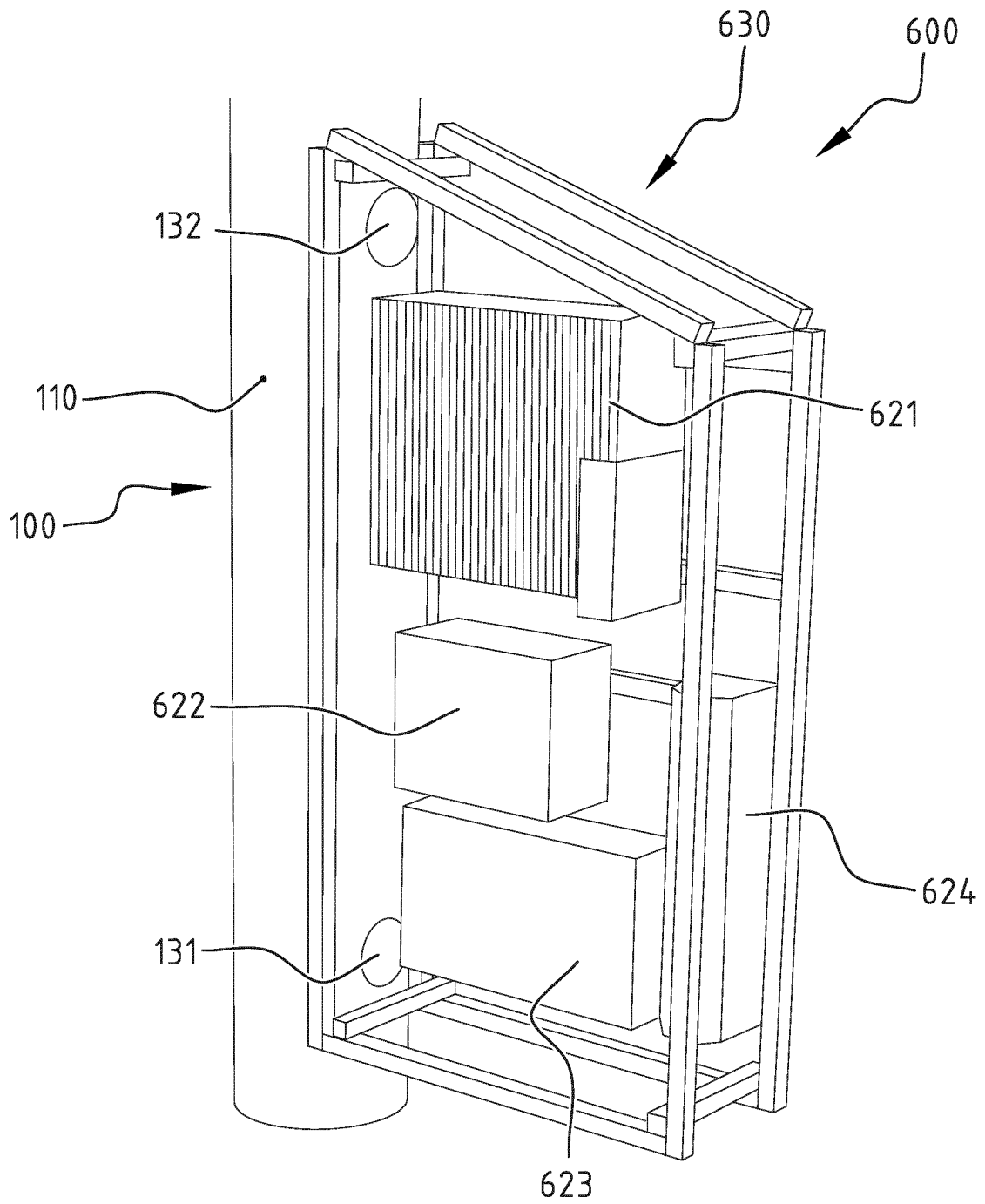

FIG. 4

5/10

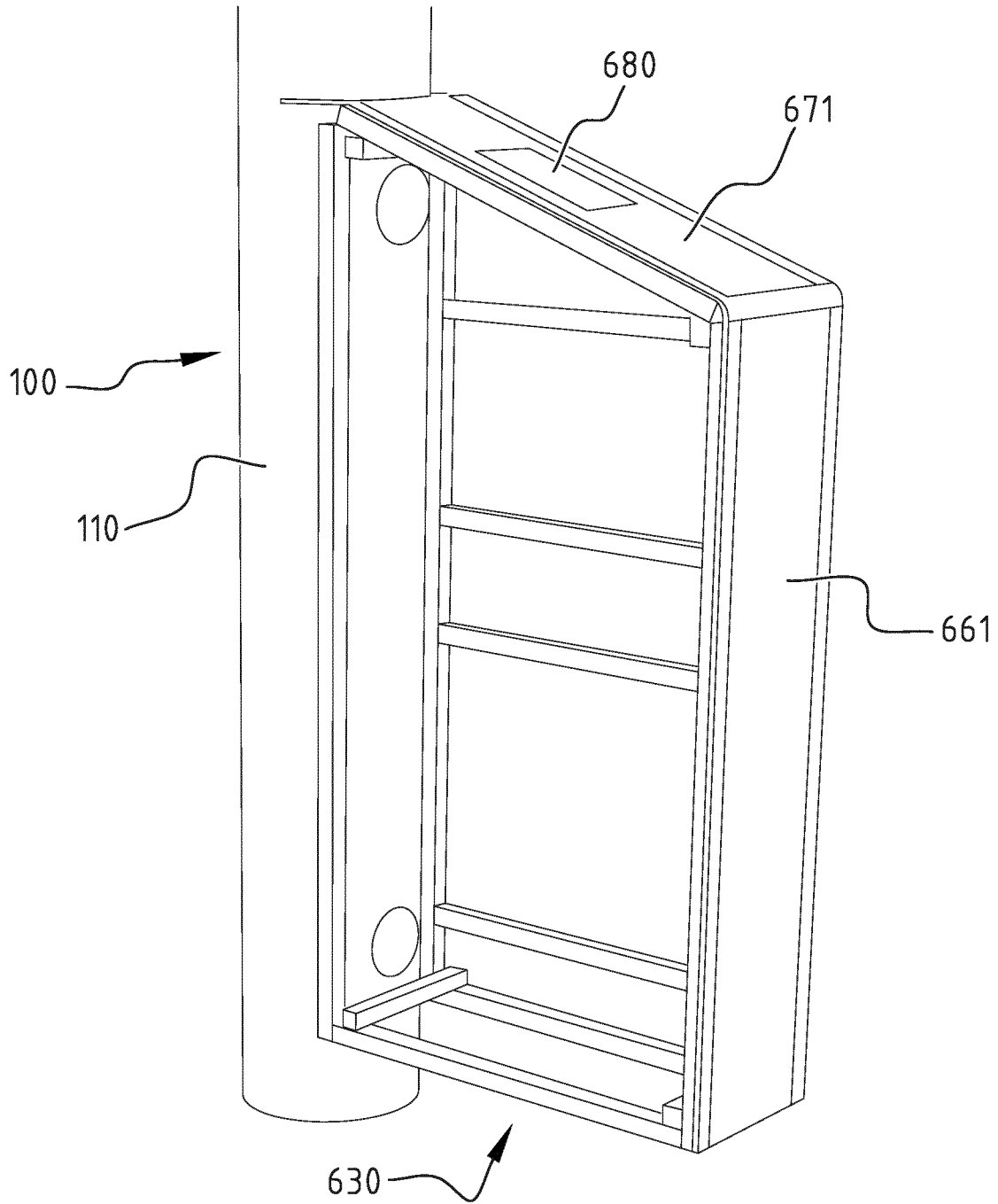

FIG. 5

6/10

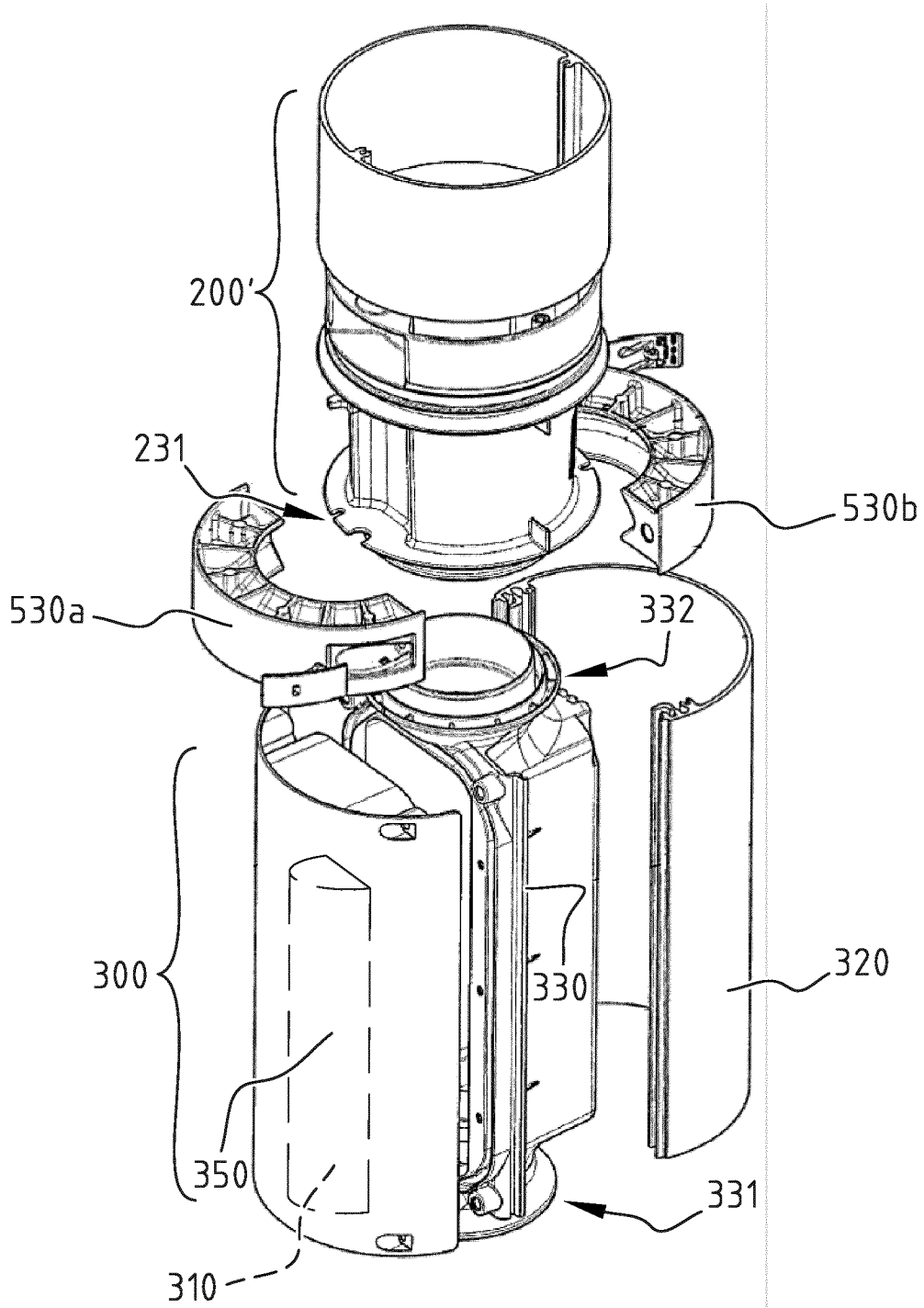

FIG. 6

7/10

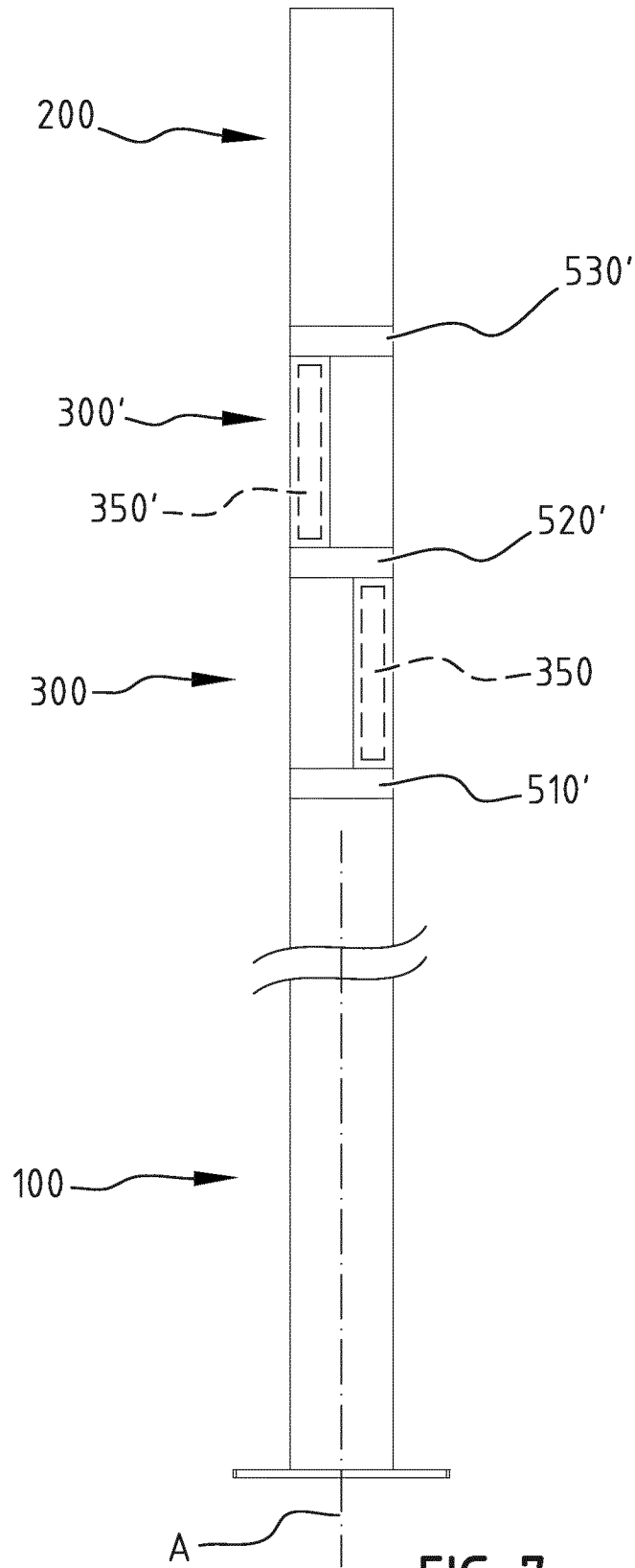

FIG. 7

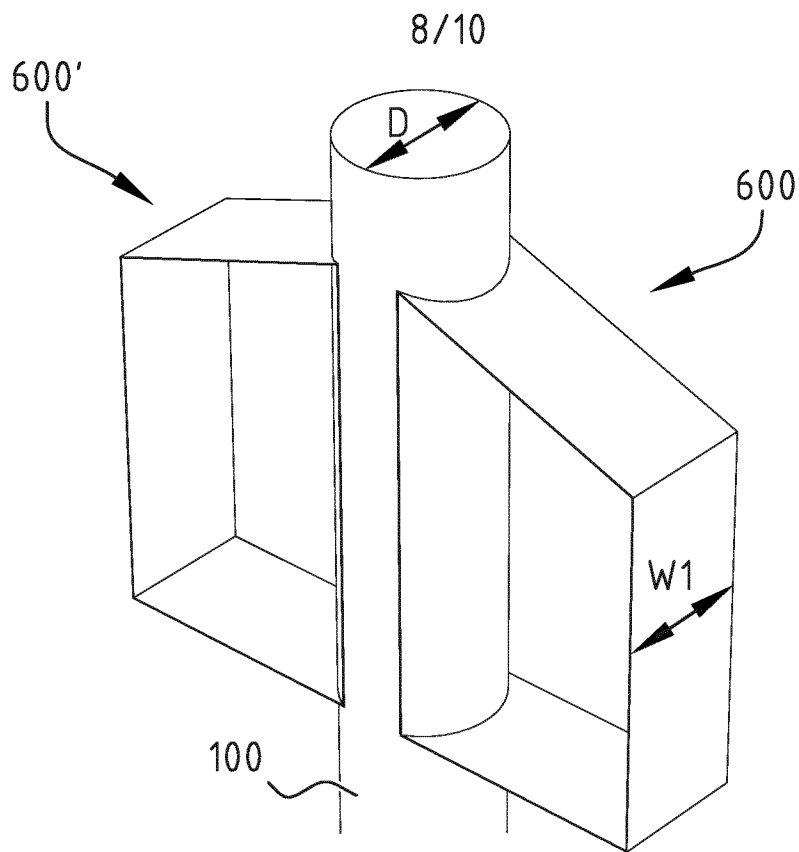

FIG. 8

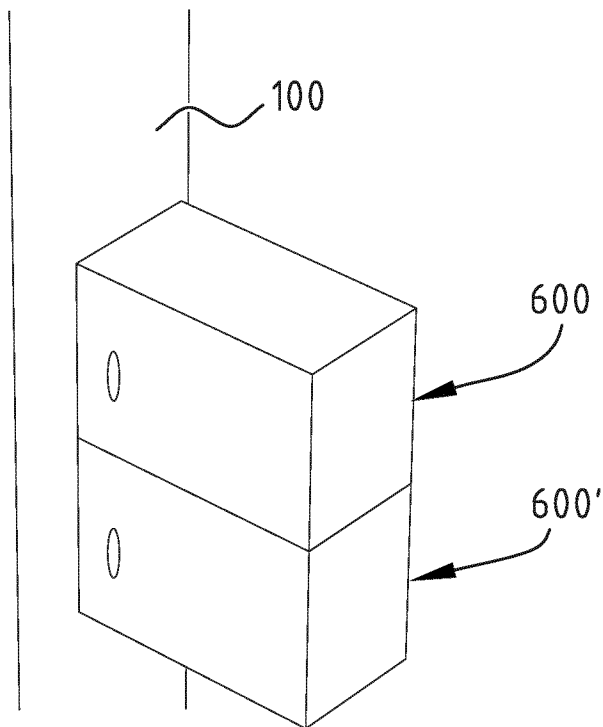

FIG. 9

9/10

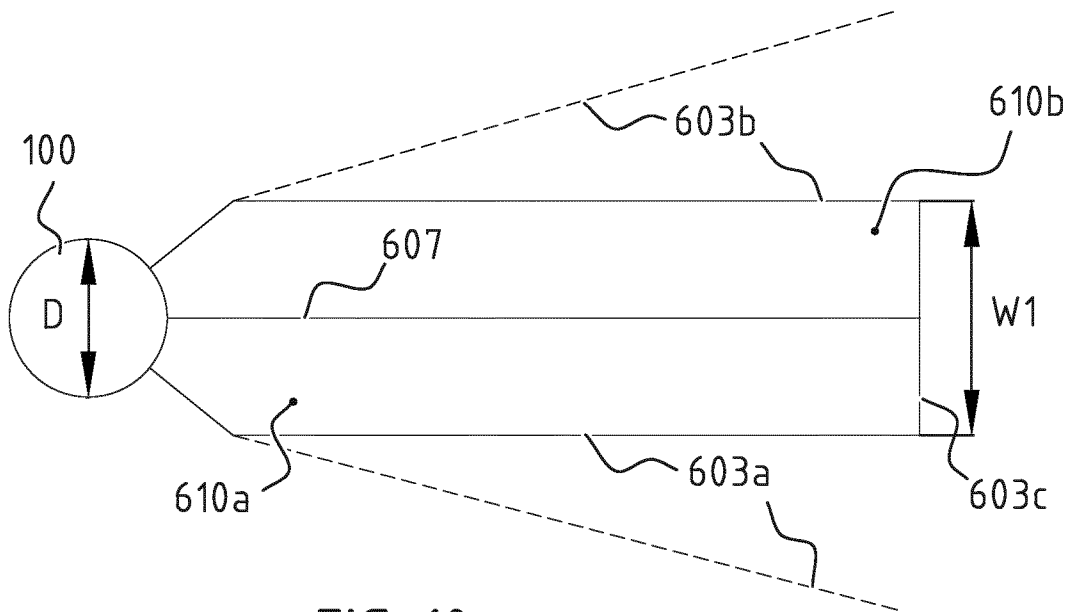

FIG. 10

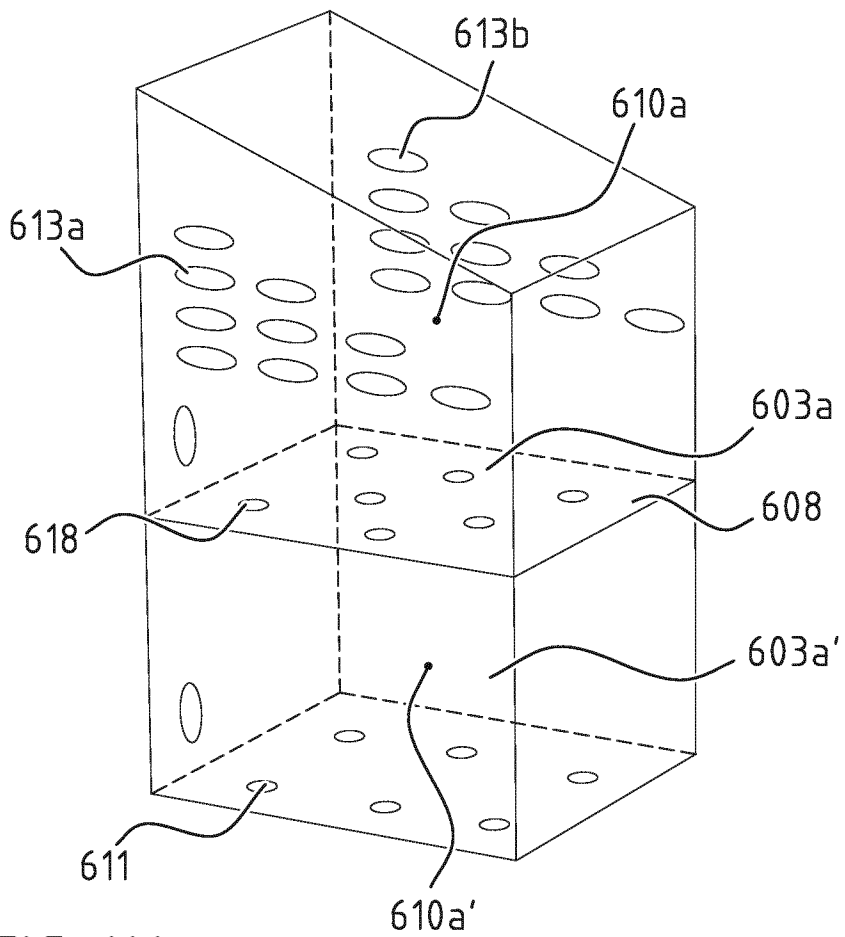

FIG. 11A

10/10

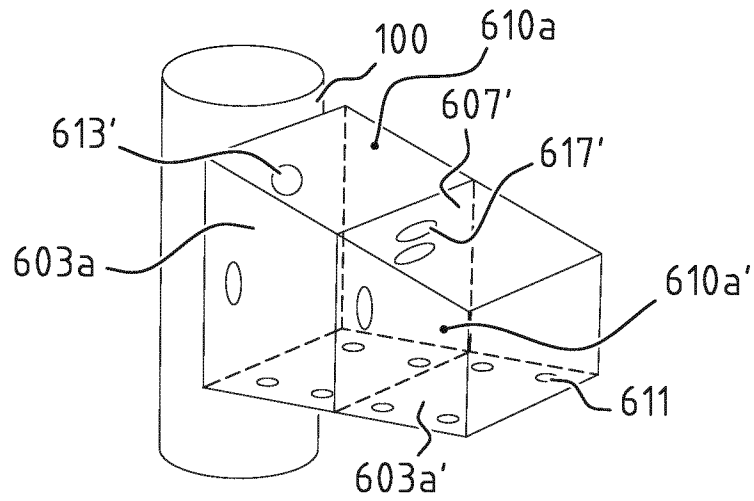

FIG. 11B

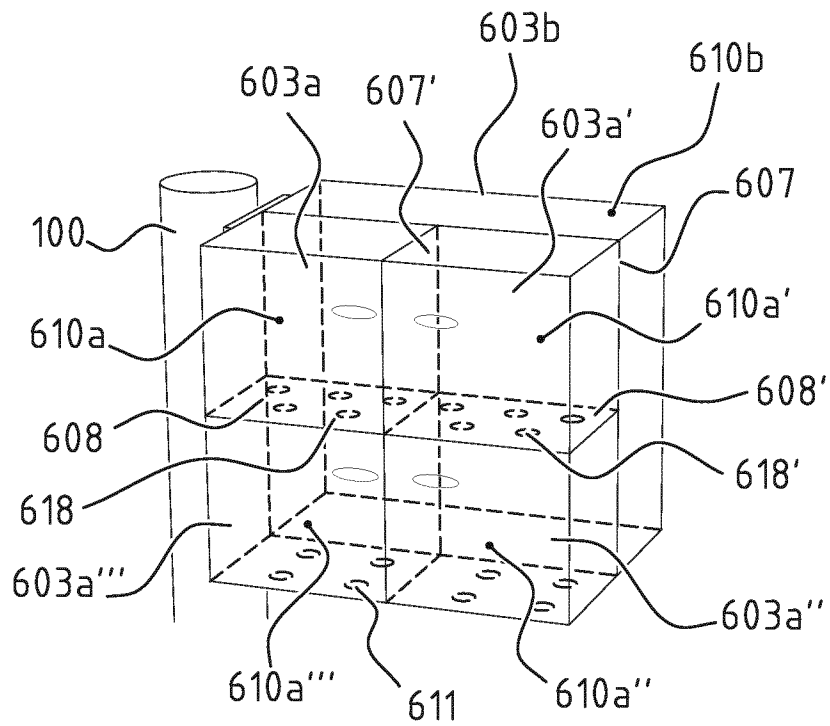

FIG. 11C

INTERNATIONAL SEARCH REPORT

International application No
PCT/EP2018/073208

A. CLASSIFICATION OF SUBJECT MATTER
 INV. F21S8/08 F21V21/10 H01Q1/12 H01Q3/04
 ADD.
 According to International Patent Classification (IPC) or to both national classification and IPC

B. FIELDS SEARCHED
 Minimum documentation searched (classification system followed by classification symbols)
 F21S F21V H01Q F21Y

Documentation searched other than minimum documentation to the extent that such documents are included in the fields searched

Electronic data base consulted during the international search (name of data base and, where practicable, search terms used)
 EPO-Internal, WPI Data

C. DOCUMENTS CONSIDERED TO BE RELEVANT

| Category* | Citation of document, with indication, where appropriate, of the relevant passages | Relevant to claim No. |
|-----------|---|---|
| X | US 2004/248511 A1 (FLYNN THOMAS [US]) 9 December 2004 (2004-12-09) paragraphs [0031] - [0034], [0042] - [0050], [0061]; figures 1,3,5,10 ----- | 1-11,13, 14,16-24 |
| X | WO 2015/183925 A1 (ENERSPHERE COMM LLC [US]; LASIER DAVID [US]; VANDONKELAAR JON [US]) 3 December 2015 (2015-12-03) paragraphs [0008], [0025] - [0033], [0059]; figures 2,6,7,8 ----- | 1-3,9, 11-19, 21, 23-34, 38,40-46 |
| X | EP 2 169 647 A1 (SUMITOMO ELECTRIC INDUSTRIES [JP]) 31 March 2010 (2010-03-31) paragraphs [0035] - [0038]; figure 1 ----- -/-- | 1,2,9, 11,15,16 |

Further documents are listed in the continuation of Box C.

See patent family annex.

* Special categories of cited documents :

| | |
|---|---|
| <p>"A" document defining the general state of the art which is not considered to be of particular relevance</p> <p>"E" earlier application or patent but published on or after the international filing date</p> <p>"L" document which may throw doubts on priority claim(s) or which is cited to establish the publication date of another citation or other special reason (as specified)</p> <p>"O" document referring to an oral disclosure, use, exhibition or other means</p> <p>"P" document published prior to the international filing date but later than the priority date claimed</p> | <p>"T" later document published after the international filing date or priority date and not in conflict with the application but cited to understand the principle or theory underlying the invention</p> <p>"X" document of particular relevance; the claimed invention cannot be considered novel or cannot be considered to involve an inventive step when the document is taken alone</p> <p>"Y" document of particular relevance; the claimed invention cannot be considered to involve an inventive step when the document is combined with one or more other such documents, such combination being obvious to a person skilled in the art</p> <p>"&" document member of the same patent family</p> |
|---|---|

| | |
|---|--|
| Date of the actual completion of the international search 21 December 2018 | Date of mailing of the international search report 21/01/2019 |
|---|--|

| | |
|--|--|
| Name and mailing address of the ISA/ European Patent Office, P.B. 5818 Patentlaan 2 NL - 2280 HV Rijswijk Tel. (+31-70) 340-2040, Fax: (+31-70) 340-3016 | Authorized officer Krikorian, Olivier |
|--|--|

INTERNATIONAL SEARCH REPORT

International application No
PCT/EP2018/073208

| C(Continuation). DOCUMENTS CONSIDERED TO BE RELEVANT | | |
|--|--|-----------------------------|
| Category* | Citation of document, with indication, where appropriate, of the relevant passages | Relevant to claim No. |
| X A | US 5 570 546 A (BUTTERWORTH ROBERT S [US] ET AL) 5 November 1996 (1996-11-05) column 6, line 37 - column 10, line 33; figures 1,2,5 | 34,38, 40,42-45 1,5,6 |
| X | ----- WO 98/53522 A1 (STEALTH NETWORK TECHNOLOGIES I [US]) 26 November 1998 (1998-11-26) claims 13-16; figure 7 | 34-40, 45,46 |
| X | ----- US 2013/083516 A1 (YOON DONG HAN [KR]) 4 April 2013 (2013-04-04) claim 1; figures 2,5 | 17,18,24 |
| X | ----- WO 2012/083354 A1 (DOBLE SIMON [AU]) 28 June 2012 (2012-06-28) figures 1A, 1G, 1H | 17,18,24 |
| | ----- | |

INTERNATIONAL SEARCH REPORT

International application No.
PCT/EP2018/073208

Box No. II Observations where certain claims were found unsearchable (Continuation of item 2 of first sheet)

This international search report has not been established in respect of certain claims under Article 17(2)(a) for the following reasons:

1. Claims Nos.:
because they relate to subject matter not required to be searched by this Authority, namely:

2. Claims Nos.:
because they relate to parts of the international application that do not comply with the prescribed requirements to such an extent that no meaningful international search can be carried out, specifically:

3. Claims Nos.:
because they are dependent claims and are not drafted in accordance with the second and third sentences of Rule 6.4(a).

Box No. III Observations where unity of invention is lacking (Continuation of item 3 of first sheet)

This International Searching Authority found multiple inventions in this international application, as follows:

see additional sheet

1. As all required additional search fees were timely paid by the applicant, this international search report covers all searchable claims.

2. As all searchable claims could be searched without effort justifying an additional fees, this Authority did not invite payment of additional fees.

3. As only some of the required additional search fees were timely paid by the applicant, this international search report covers only those claims for which fees were paid, specifically claims Nos.:

4. No required additional search fees were timely paid by the applicant. Consequently, this international search report is restricted to the invention first mentioned in the claims; it is covered by claims Nos.:

Remark on Protest

- The additional search fees were accompanied by the applicant's protest and, where applicable, the payment of a protest fee.
- The additional search fees were accompanied by the applicant's protest but the applicable protest fee was not paid within the time limit specified in the invitation.
- No protest accompanied the payment of additional search fees.

FURTHER INFORMATION CONTINUED FROM PCT/ISA/ 210

This International Searching Authority found multiple (groups of) inventions in this international application, as follows:

1. claims: 1-16

Lamp post with an antenna module and a base station module coupled to the antenna

2. claims: 17-33

Lamp post with a functional module comprising a ribbed frame

3. claims: 34-46

Lamp post with two rotatable antenna modules

INTERNATIONAL SEARCH REPORT

Information on patent family members

| |
|---|
| International application No PCT/EP2018/073208 |
|---|

| Patent document cited in search report | Publication date | Patent family member(s) | Publication date |
|--|------------------|-------------------------|---|
| US 2004248511 | A1 | 09-12-2004 | NONE |
| ----- | | | |
| WO 2015183925 | A1 | 03-12-2015 | US 2015349399 A1 WO 2015183925 A1 |
| ----- | | | |
| EP 2169647 | A1 | 31-03-2010 | CN 101743573 A EP 2169647 A1 EP 2315190 A1 US 2010188301 A1 WO 2009011218 A1 |
| ----- | | | |
| US 5570546 | A | 05-11-1996 | AU 6715596 A CA 2228135 A1 US 5570546 A WO 9705670 A1 |
| ----- | | | |
| WO 9853522 | A1 | 26-11-1998 | AU 7495398 A WO 9853522 A1 |
| ----- | | | |
| US 2013083516 | A1 | 04-04-2013 | CN 102939499 A KR 20110136287 A US 2013083516 A1 WO 2011159076 A2 |
| ----- | | | |
| WO 2012083354 | A1 | 28-06-2012 | CA 2822341 A1 CN 103403281 A EP 2655764 A1 JP 2014507045 A KR 20140016253 A SG 191240 A1 TW 201243223 A US 2013271966 A1 WO 2012083354 A1 ZA 201305464 B |
| ----- | | | |