



US 20080256989A1

(19) **United States**

(12) **Patent Application Publication**  
**Jeong et al.**

(10) **Pub. No.: US 2008/0256989 A1**

(43) **Pub. Date: Oct. 23, 2008**

(54) **REFRESHER AND MACHINE FOR WASHING OR DRYING WITH THE SAME**

(30) **Foreign Application Priority Data**

(75) Inventors: **Seong Hai Jeong**,  
Gyeongsangnam-do (KR); **Soung Bong Choi**, Gyeongsangnam-do (KR); **Byung Hwan Ahn**, Gyeongsangnam-do (KR); **Hyeok Deok Kim**, Gyeongsangnam-do (KR); **Deug Hee Lee**, Gyeongsangnam-do (KR); **Hung Myong Cho**, Gyeongsangnam-do (KR)

Feb. 8, 2005	(KR)	10-2005-0017048
Feb. 8, 2005	(KR)	10-2005-0017147
Feb. 28, 2005	(KR)	10-2005-0016811
Feb. 28, 2005	(KR)	10-2005-0016816
Feb. 28, 2005	(KR)	10-2005-0016822
Feb. 28, 2005	(KR)	10-2005-0016831
Feb. 28, 2005	(KR)	10-2005-0017044
Feb. 28, 2005	(KR)	10-2005-0017045
Feb. 28, 2005	(KR)	10-2005-0017046
Feb. 28, 2005	(KR)	10-2005-0017053
Mar. 8, 2005	(KR)	10-2005-0019104
Mar. 8, 2005	(KR)	10-2005-0019105

Correspondence Address:  
**MCKENNA LONG & ALDRIDGE LLP**  
**1900 K STREET, NW**  
**WASHINGTON, DC 20006 (US)**

**Publication Classification**

(73) Assignee: **LG ELECTRONICS INC.**, Seoul (KR)

(51) **Int. Cl.**  
**D06F 37/00** (2006.01)  
**F24H 1/18** (2006.01)  
**D06F 37/26** (2006.01)

(52) **U.S. Cl.** ..... **68/5 C**; 392/441; 68/6

(21) Appl. No.: **11/628,193**

(57) **ABSTRACT**

(22) PCT Filed: **Feb. 28, 2006**

An apparatus for clothes, more particularly, a new clothes refresher for de-wrinkling and sterilizing clothes is disclosed. The clothes refresher includes a body (400) configured to receive clothes therein, and a steam supply device (200) to supply steam into the body (400) in order to supply the steam to the clothes.

(86) PCT No.: **PCT/KR06/00696**

§ 371 (c)(1),  
(2), (4) Date: **Jan. 10, 2008**

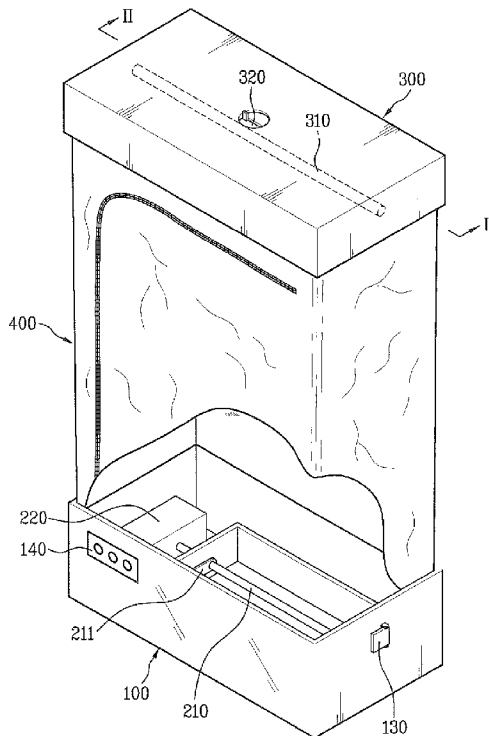

[Fig. 1]

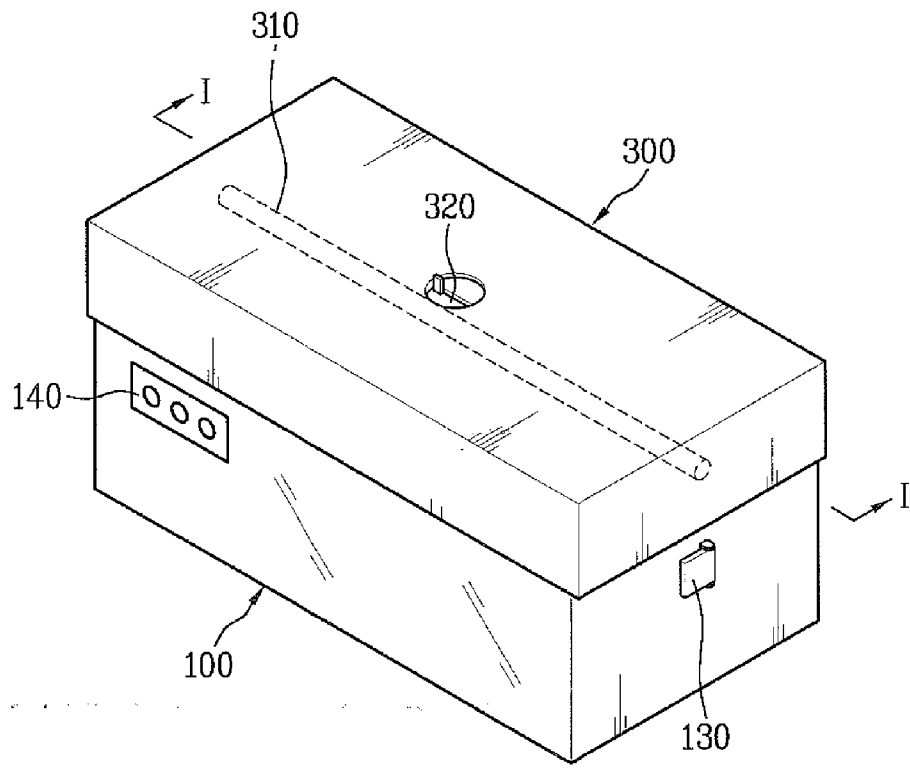

[Fig. 2]

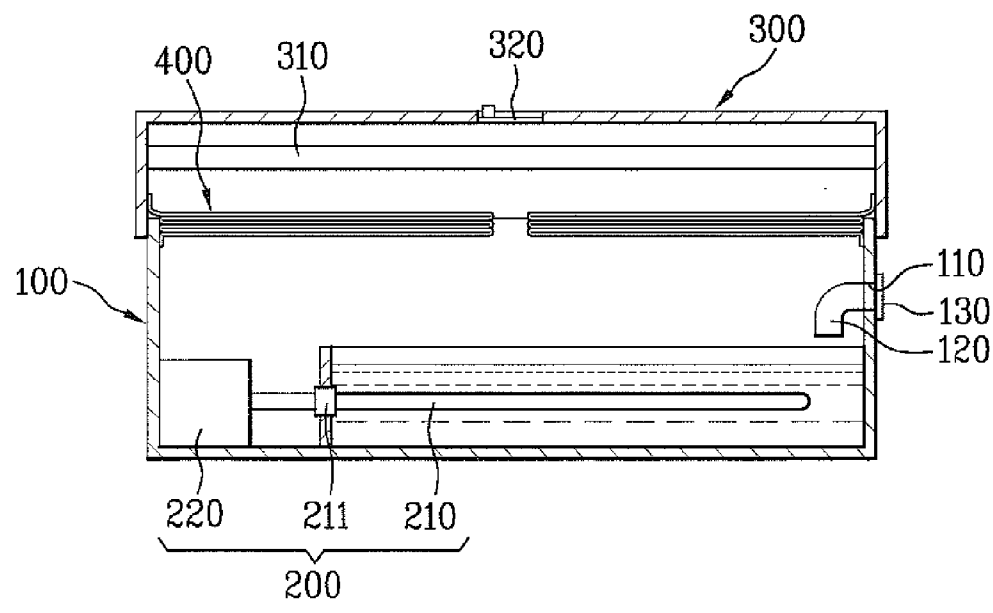

[Fig. 3]

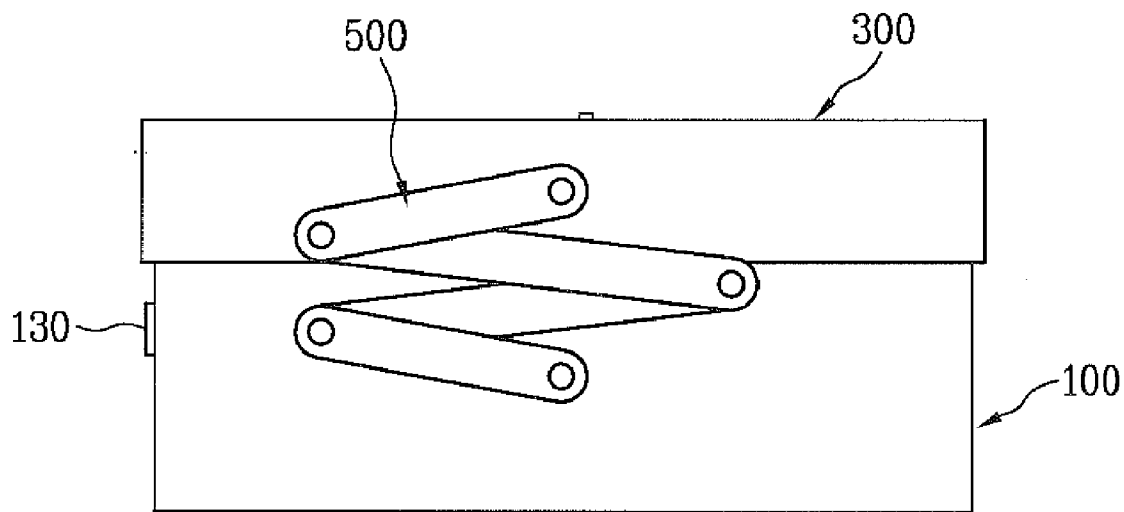

[Fig. 4]

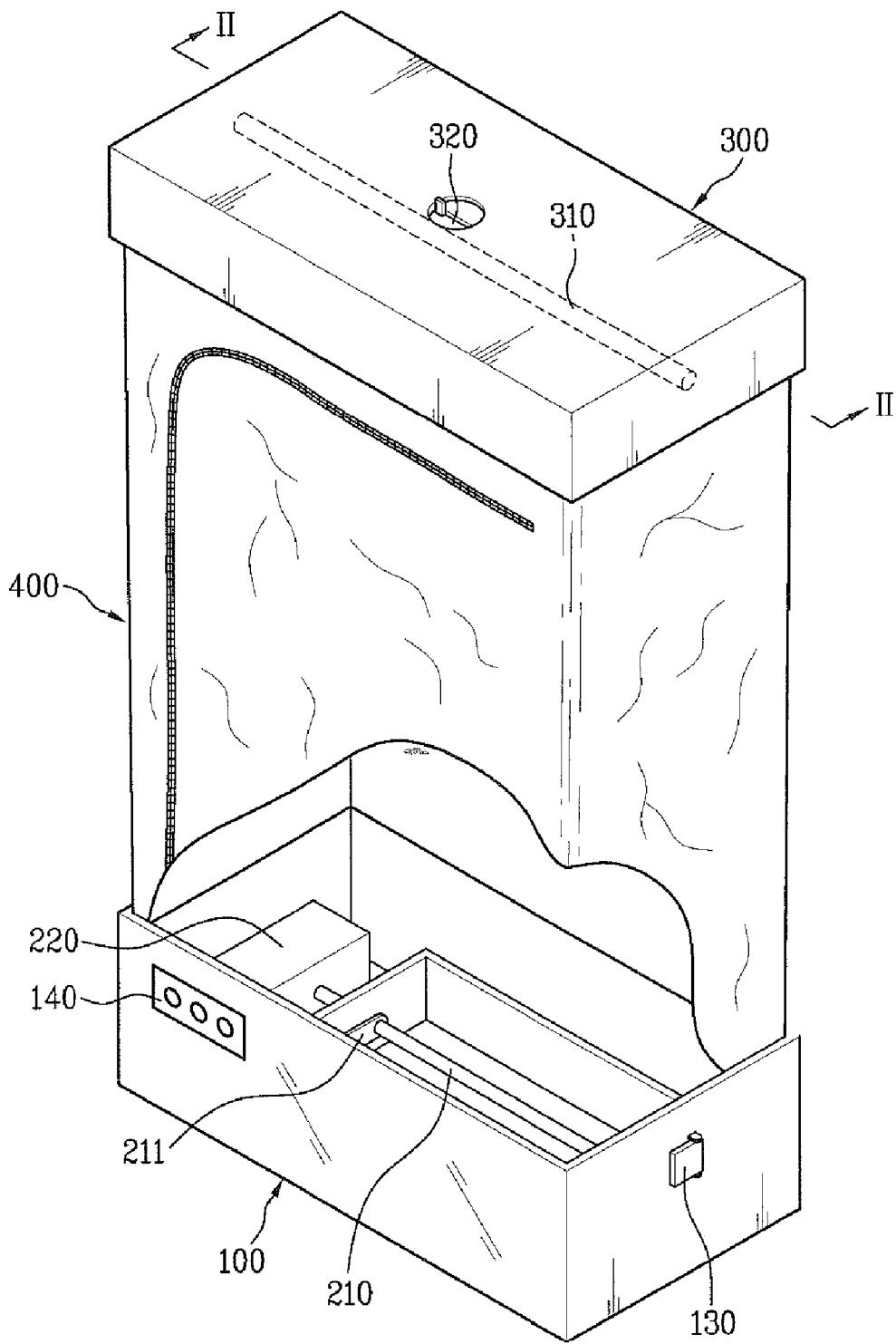

[Fig. 5]

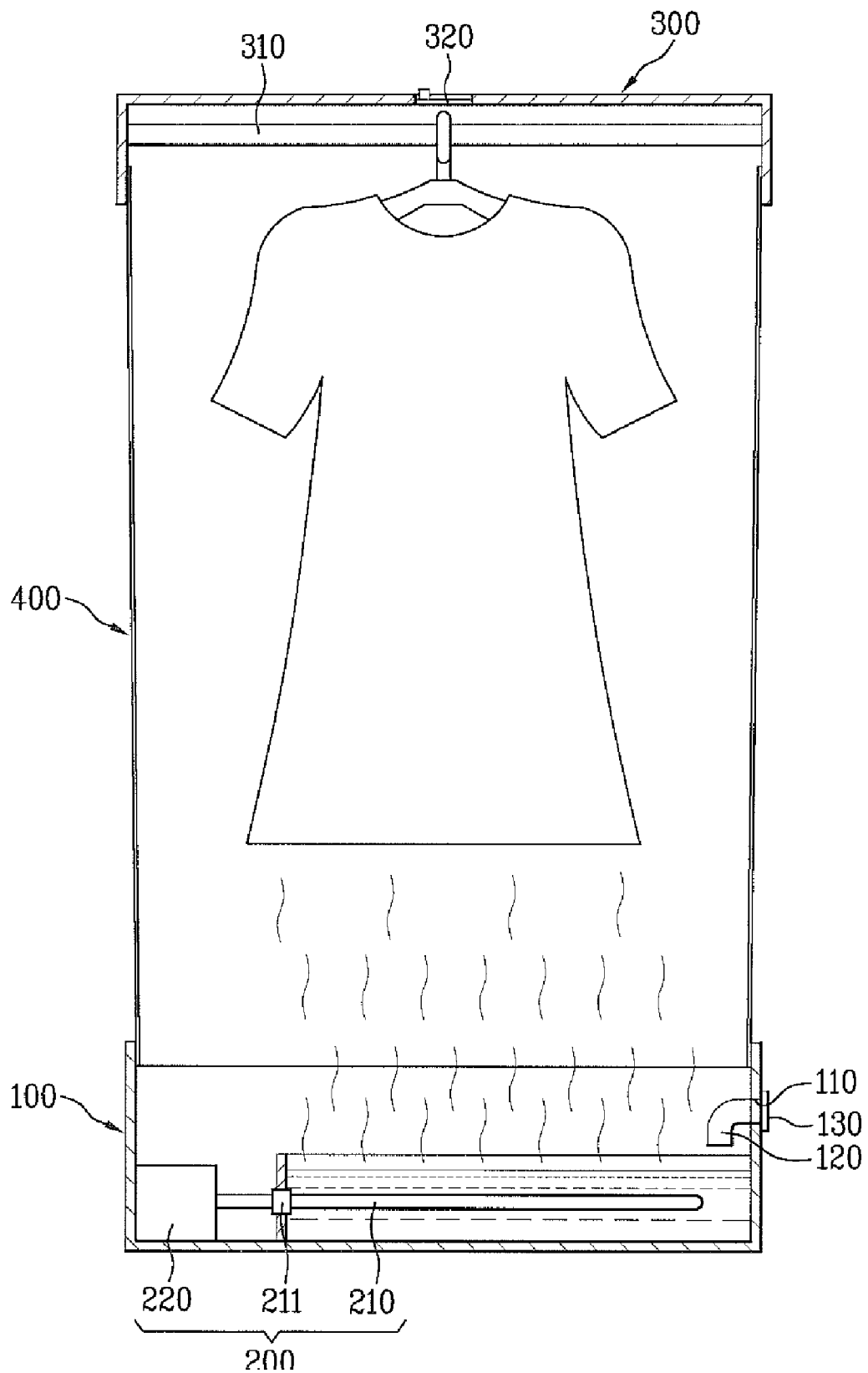

[Fig. 6]

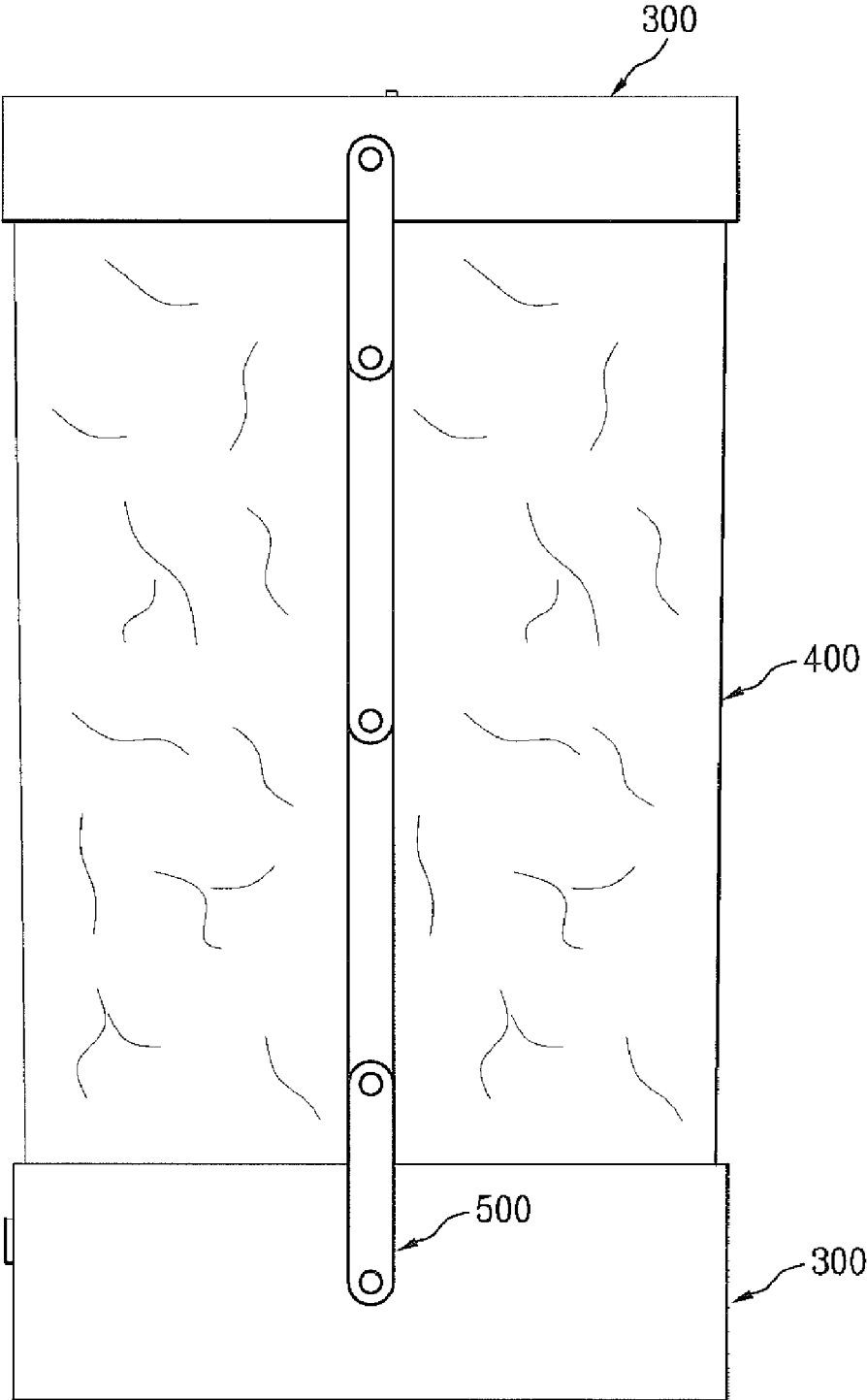

[Fig. 7]

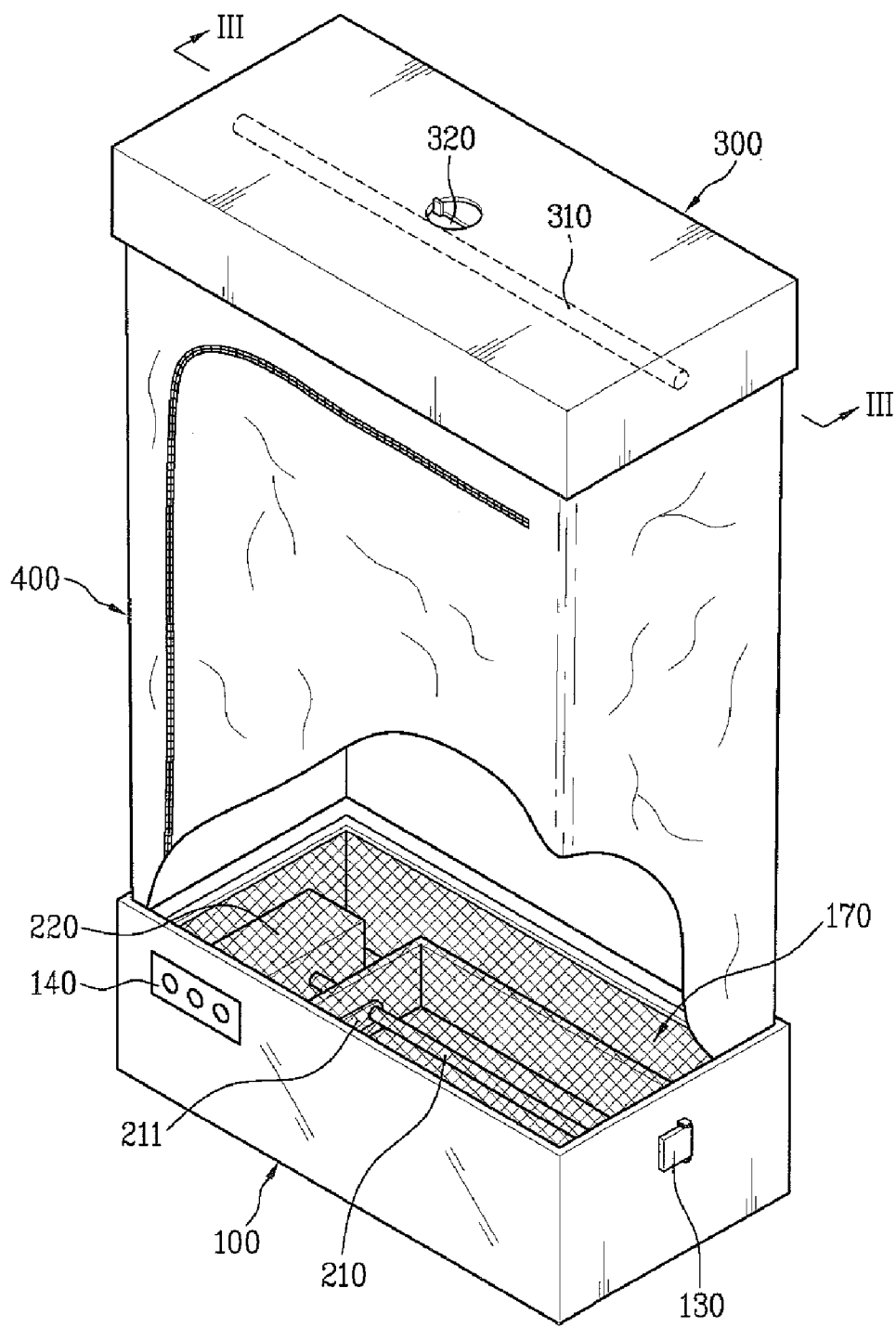

[Fig. 8]

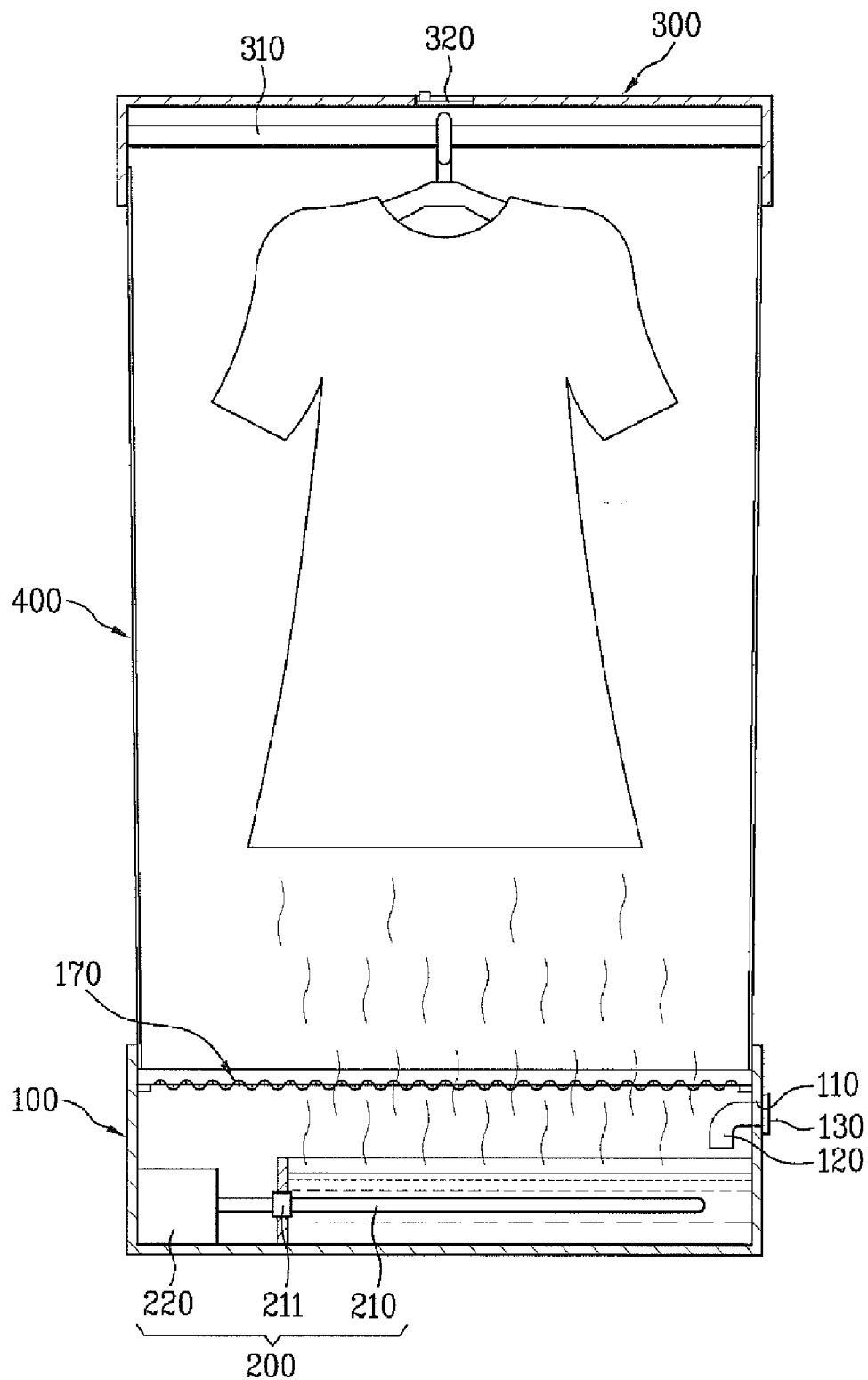



[Fig. 9]

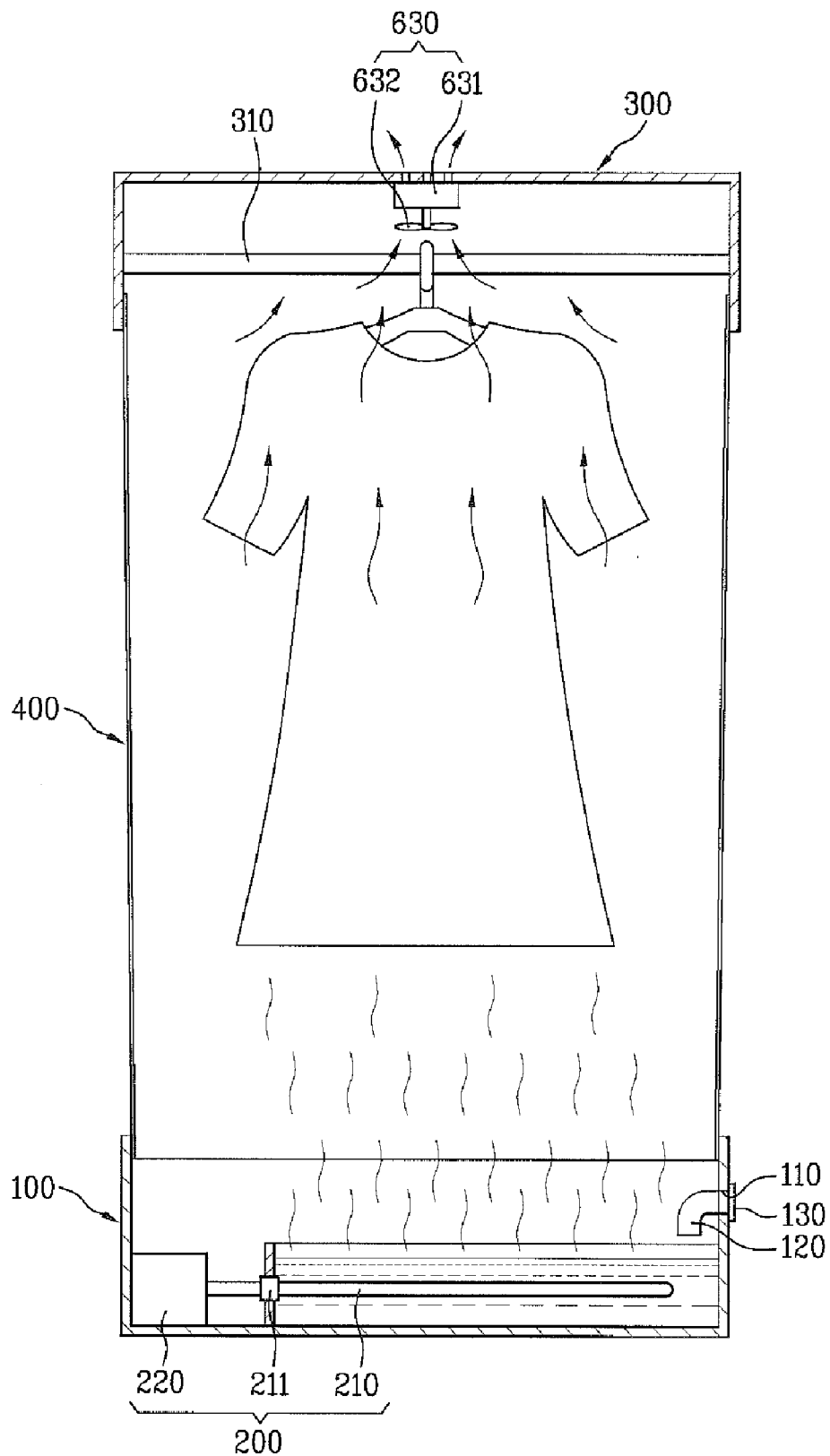

[Fig. 10]

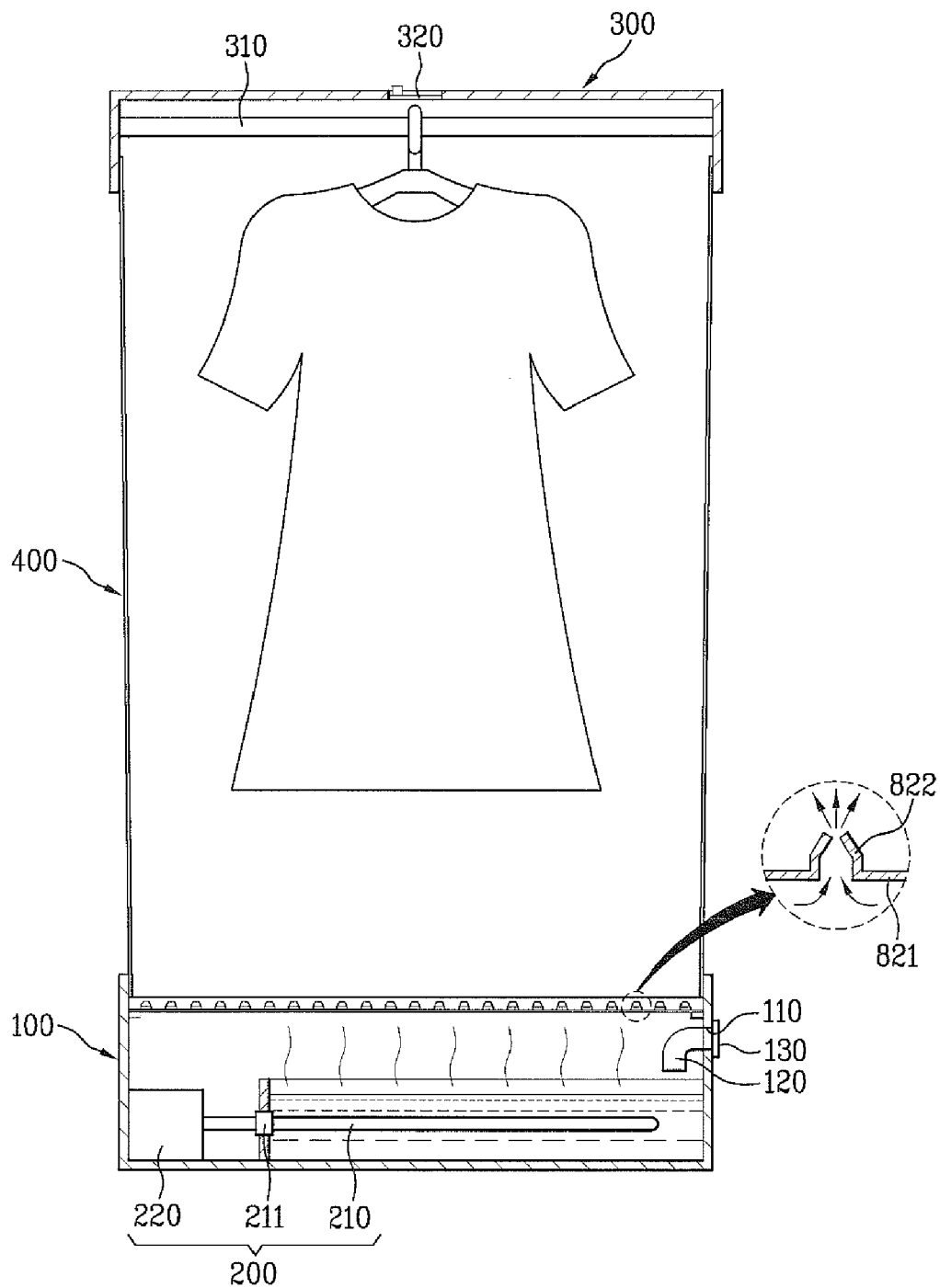

[Fig. 11]

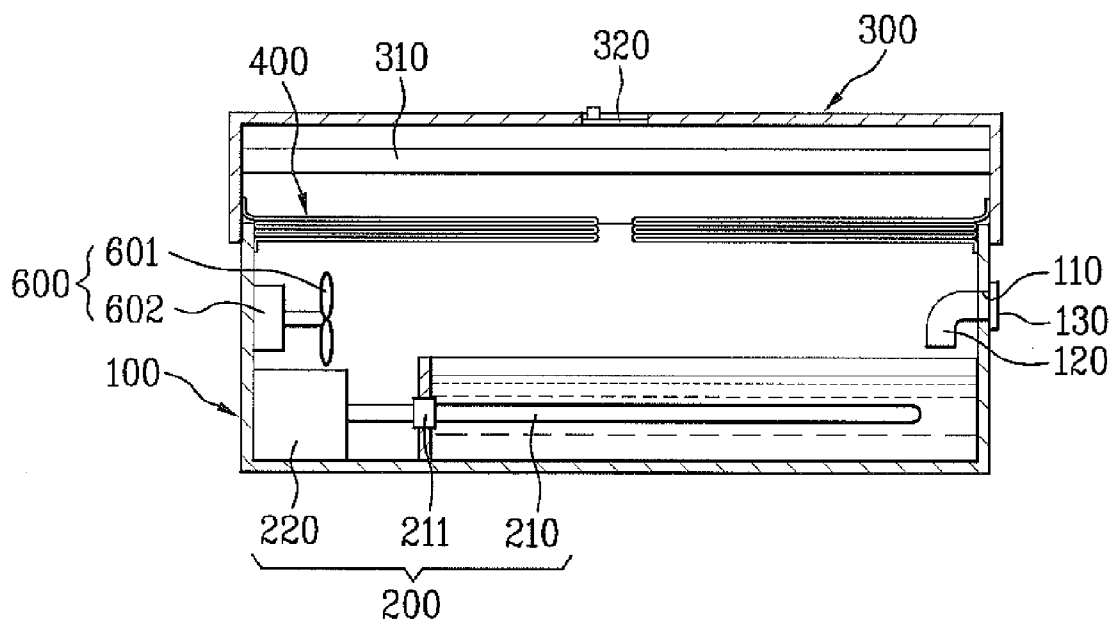

[Fig. 12]

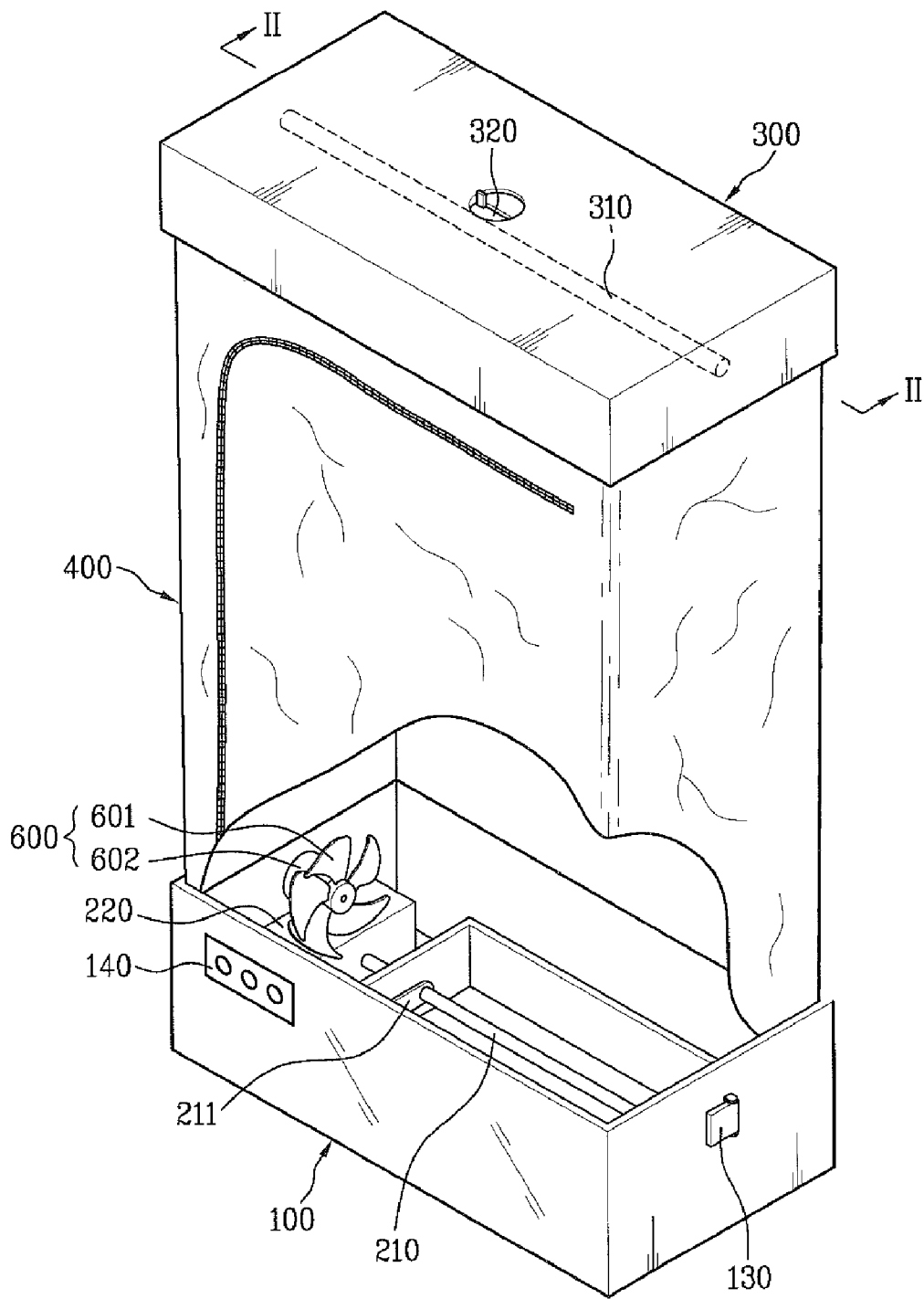

[Fig. 13]

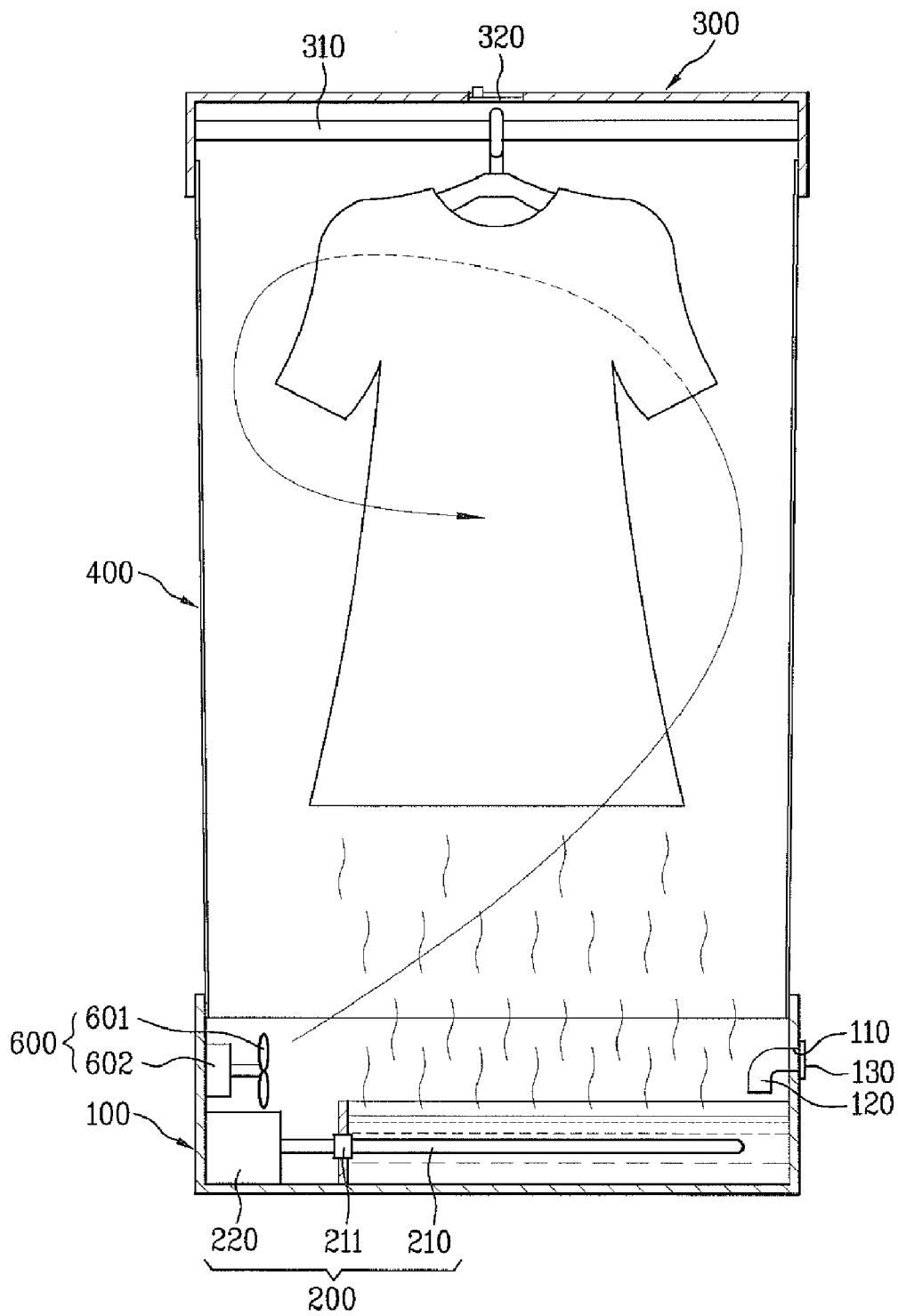

[Fig. 14]

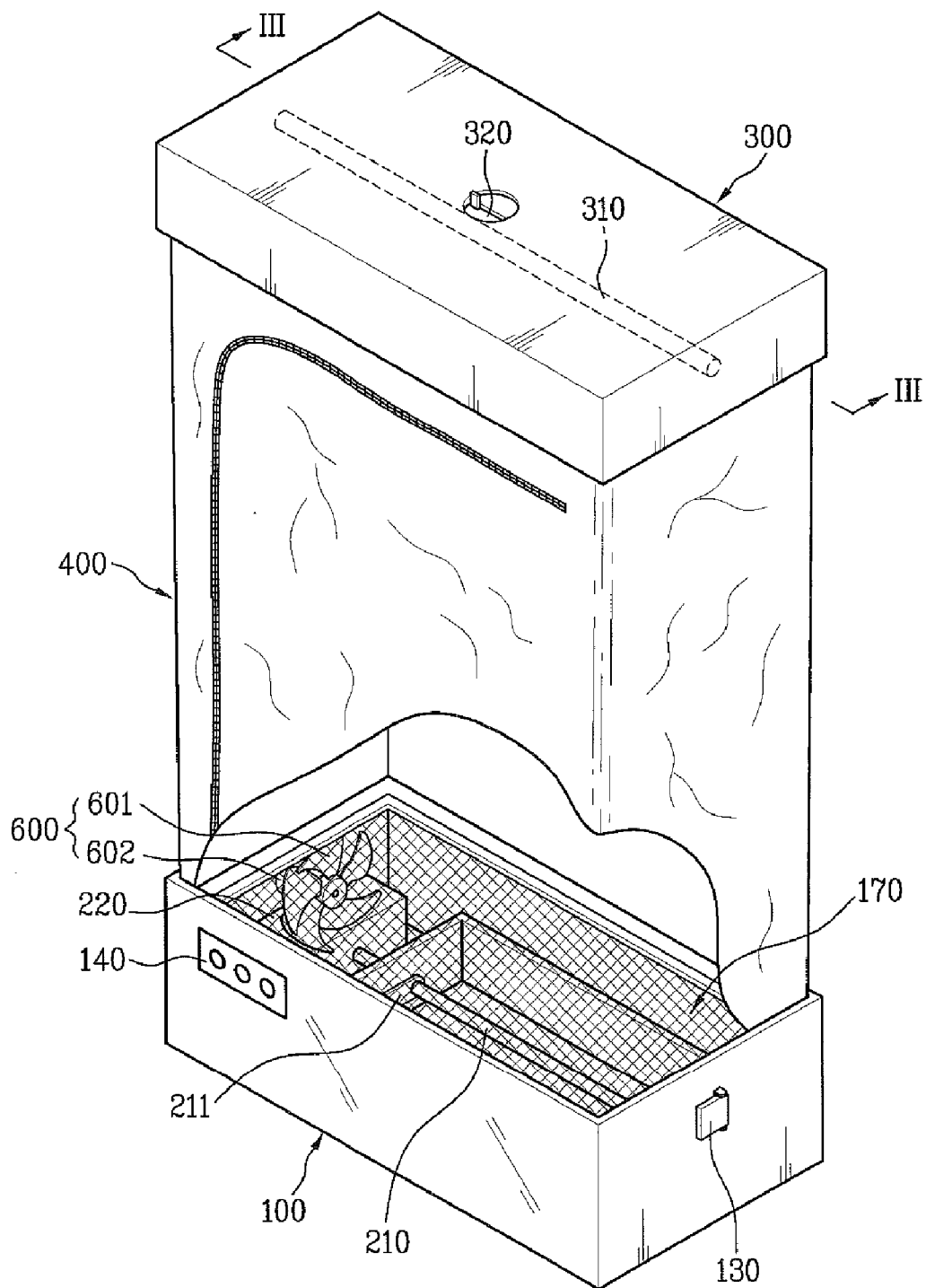

[Fig. 15]

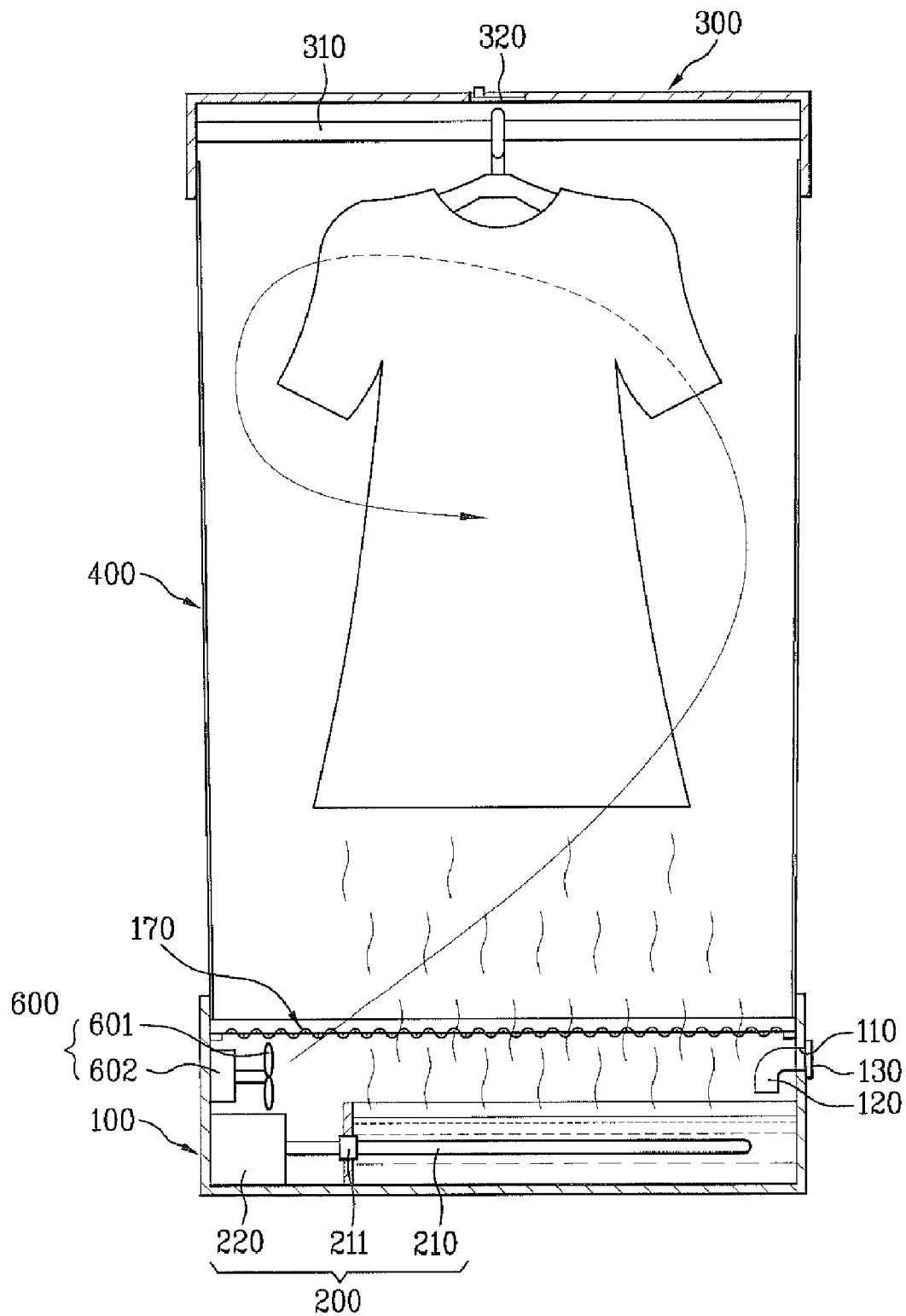

[Fig. 16]

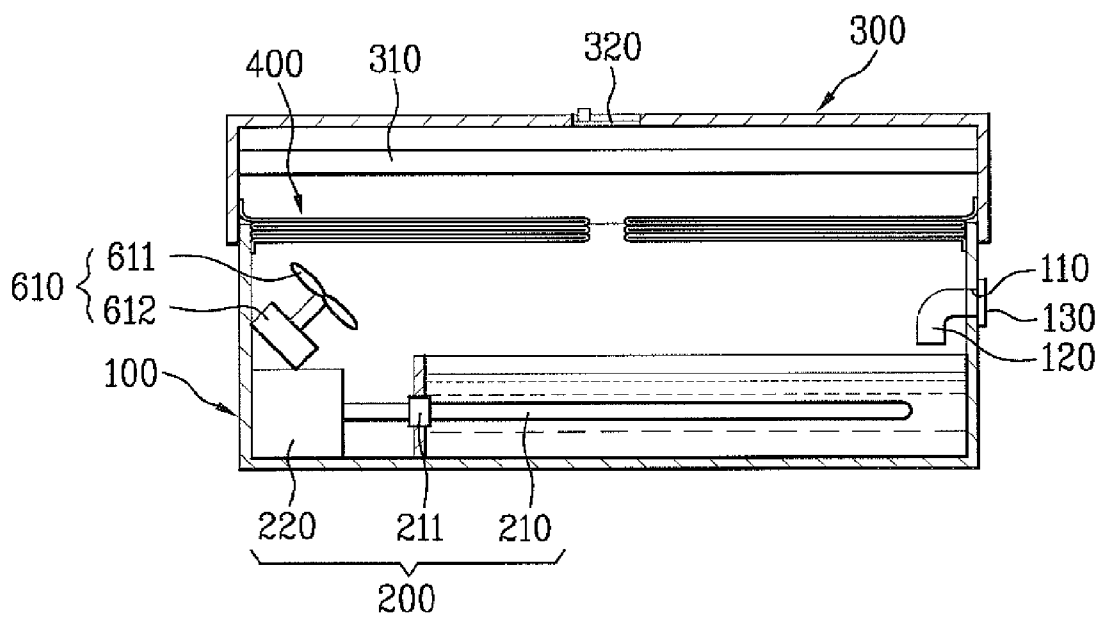



[Fig. 17]

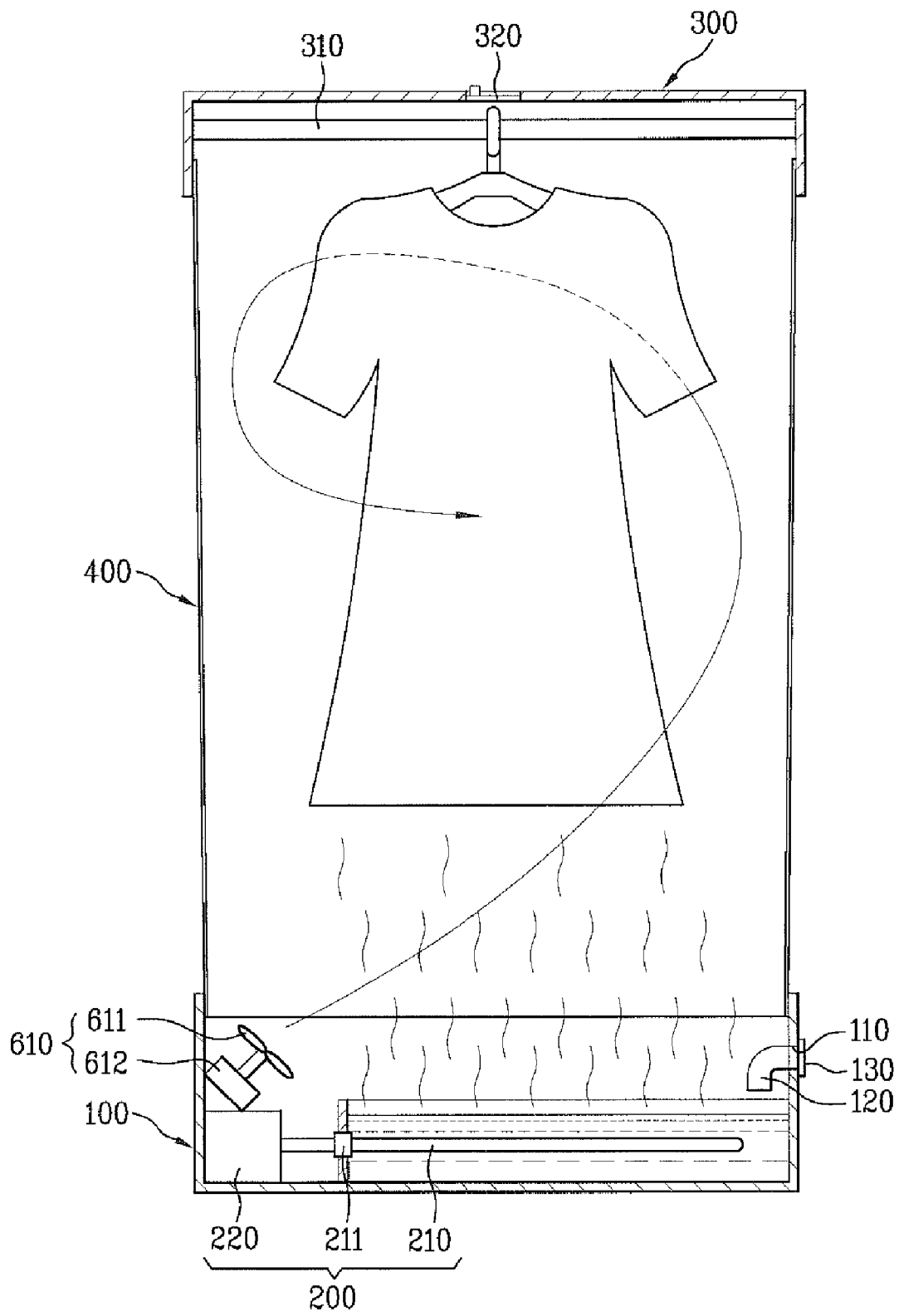

[Fig. 18]

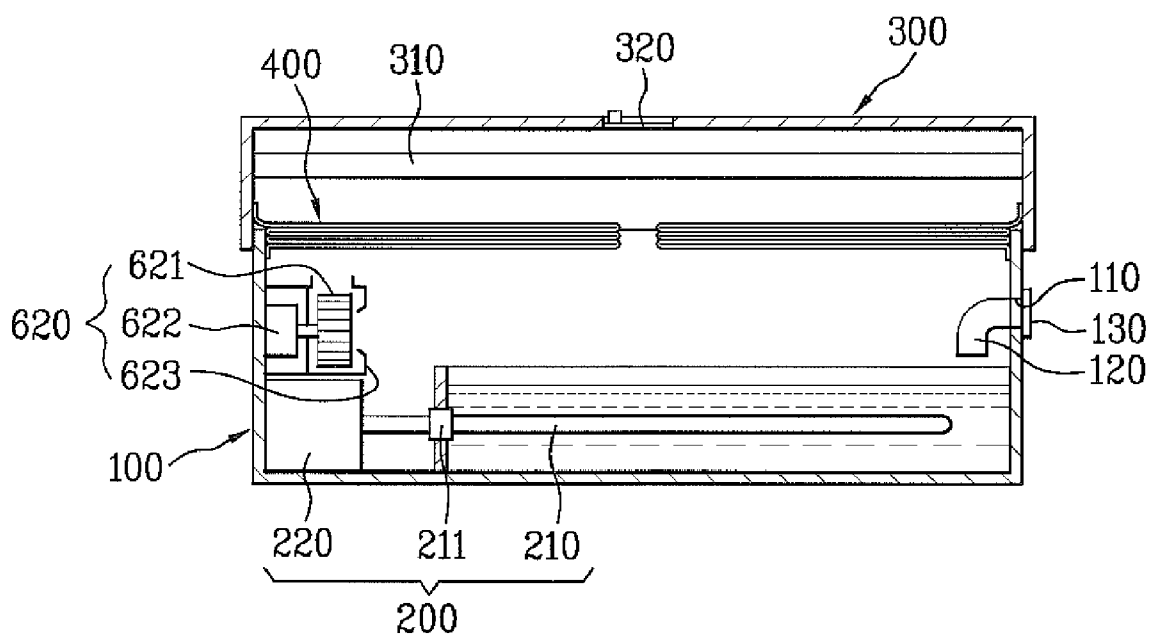

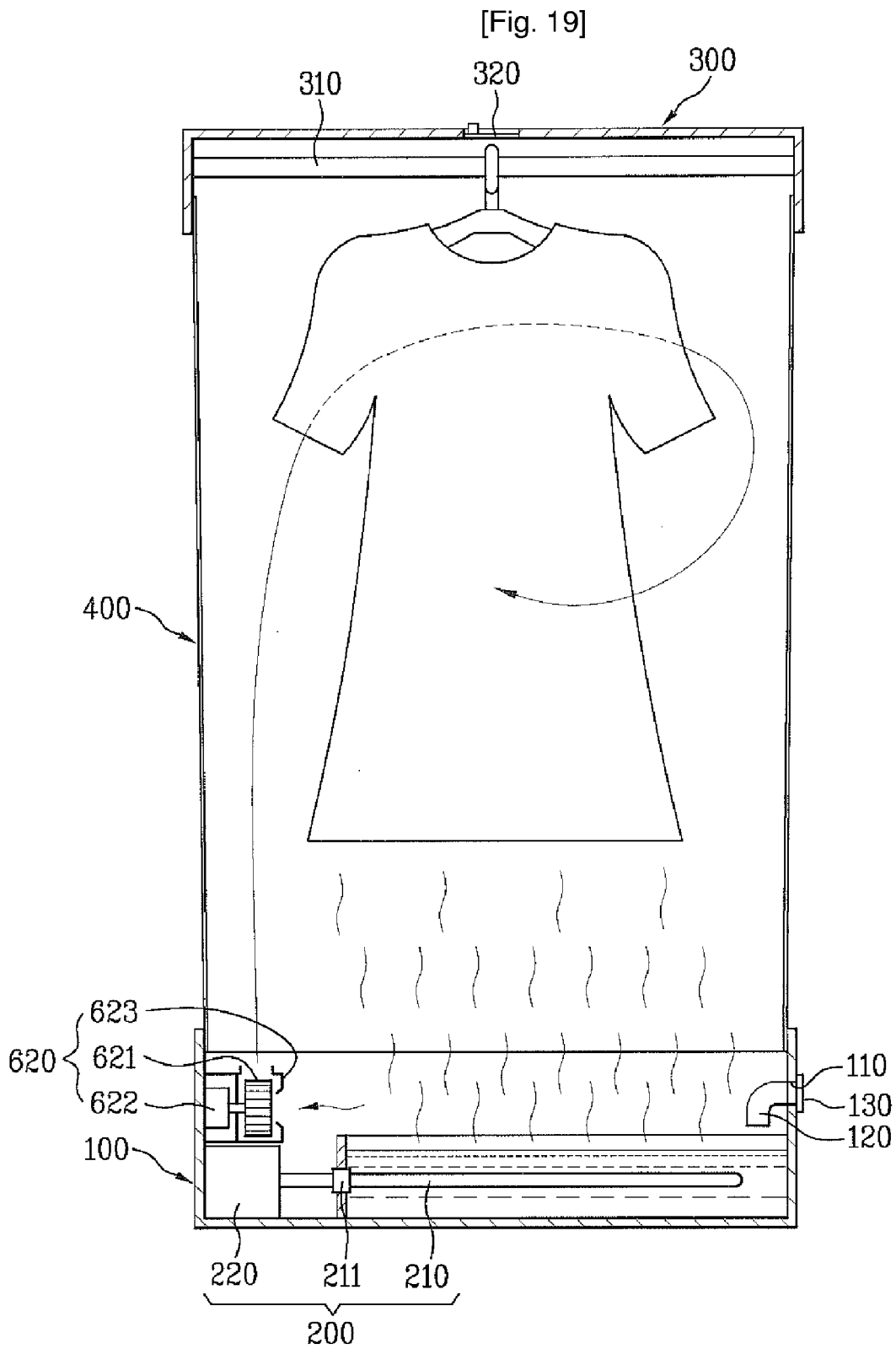

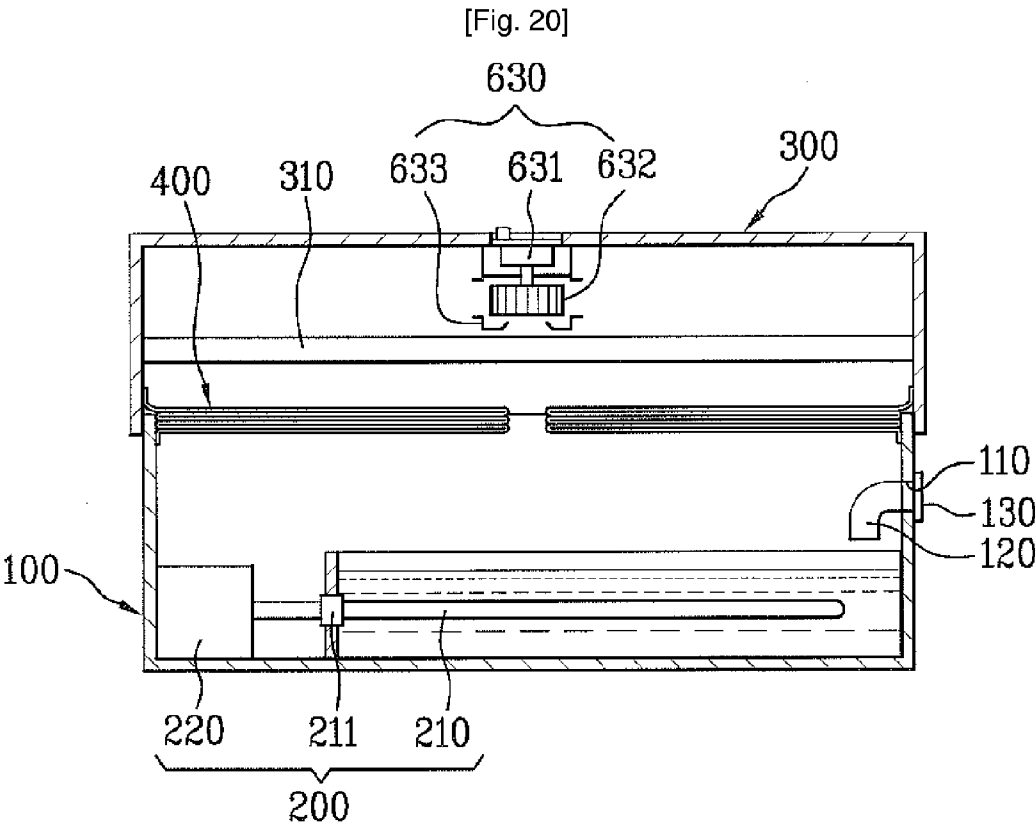

[Fig. 21]

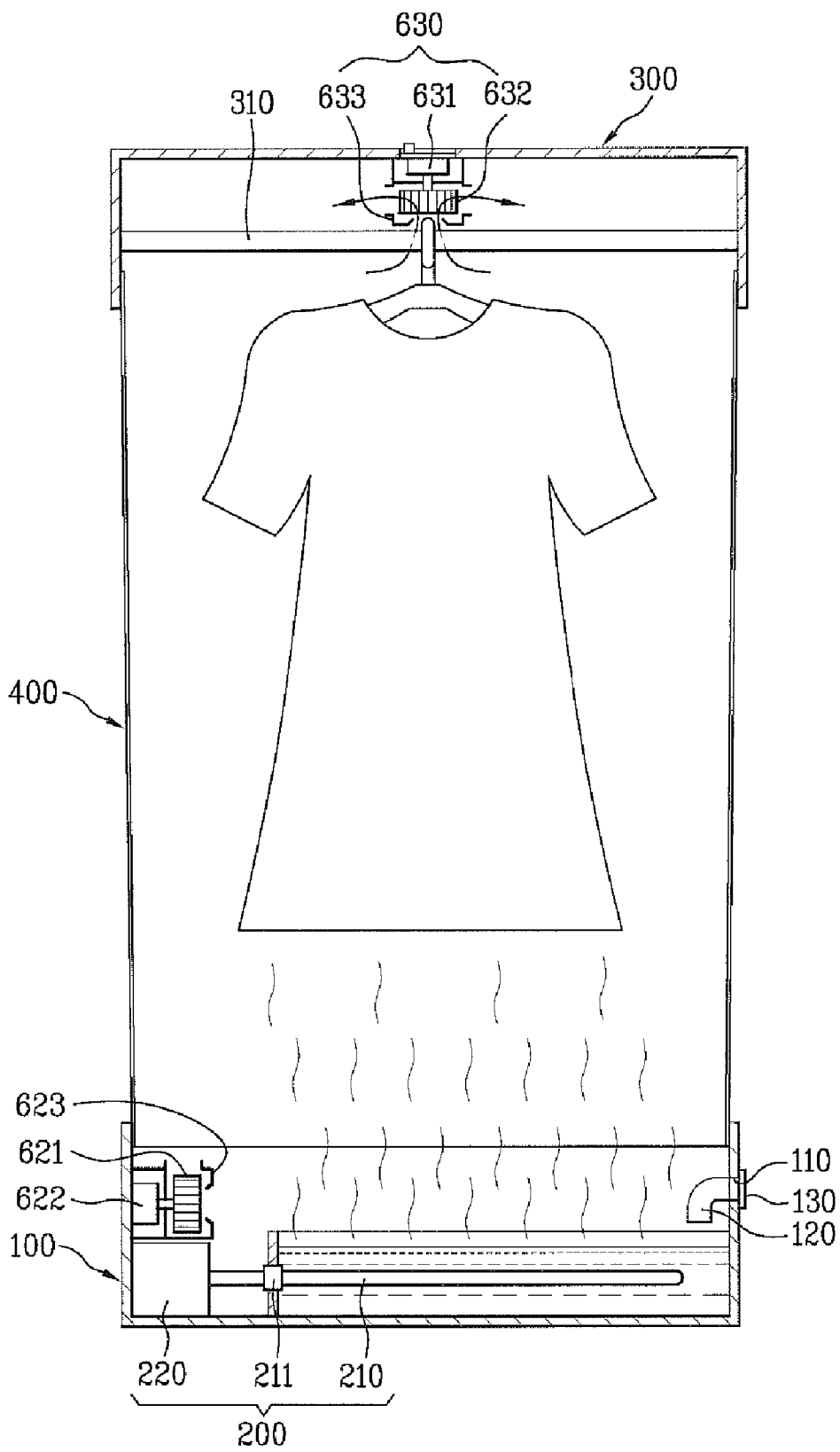

[Fig. 22]

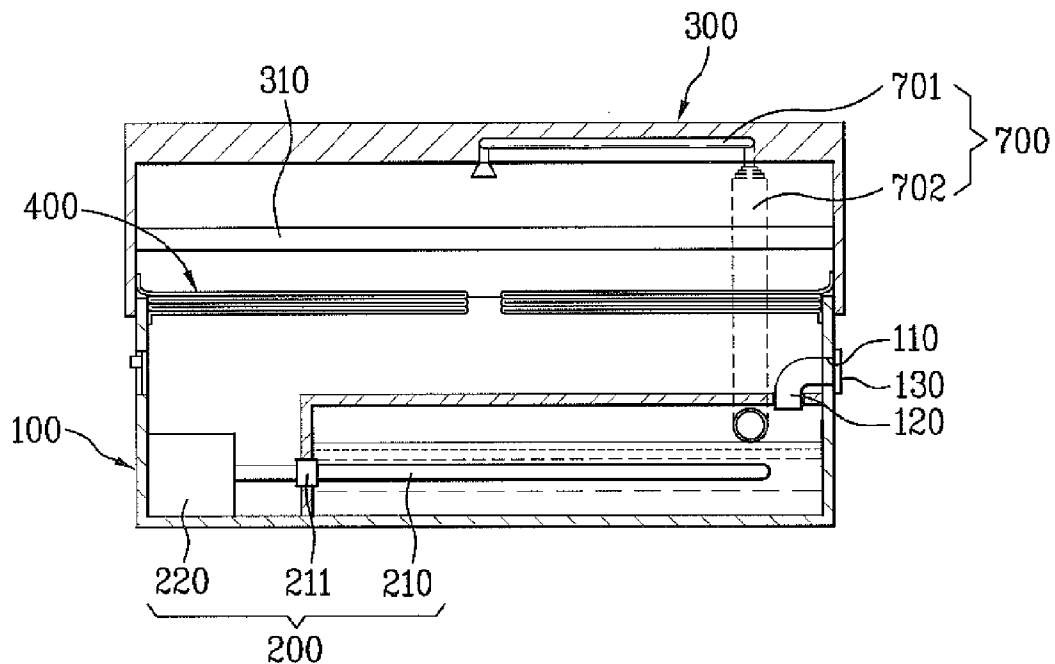

[Fig. 23]

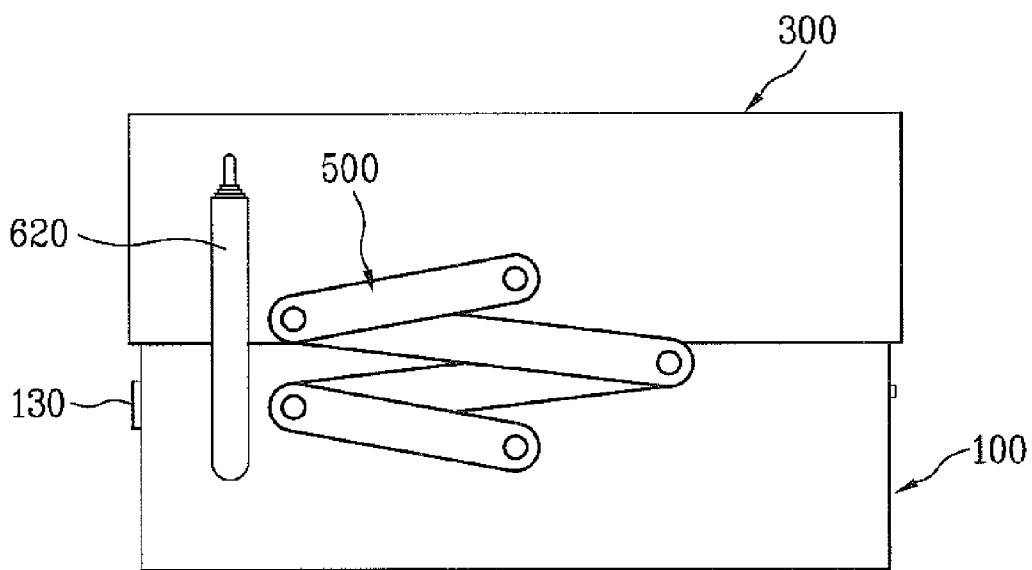

[Fig. 24]

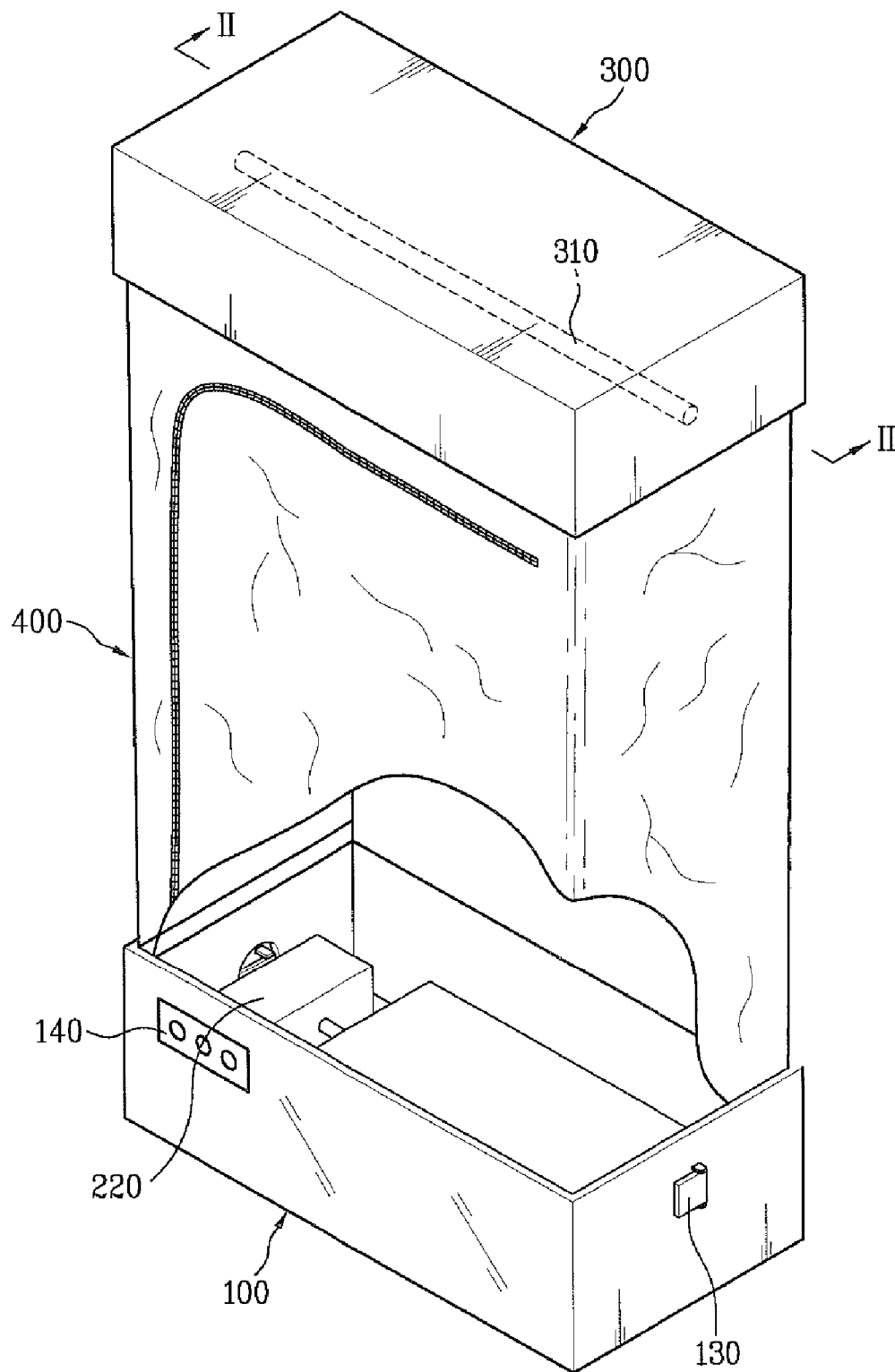

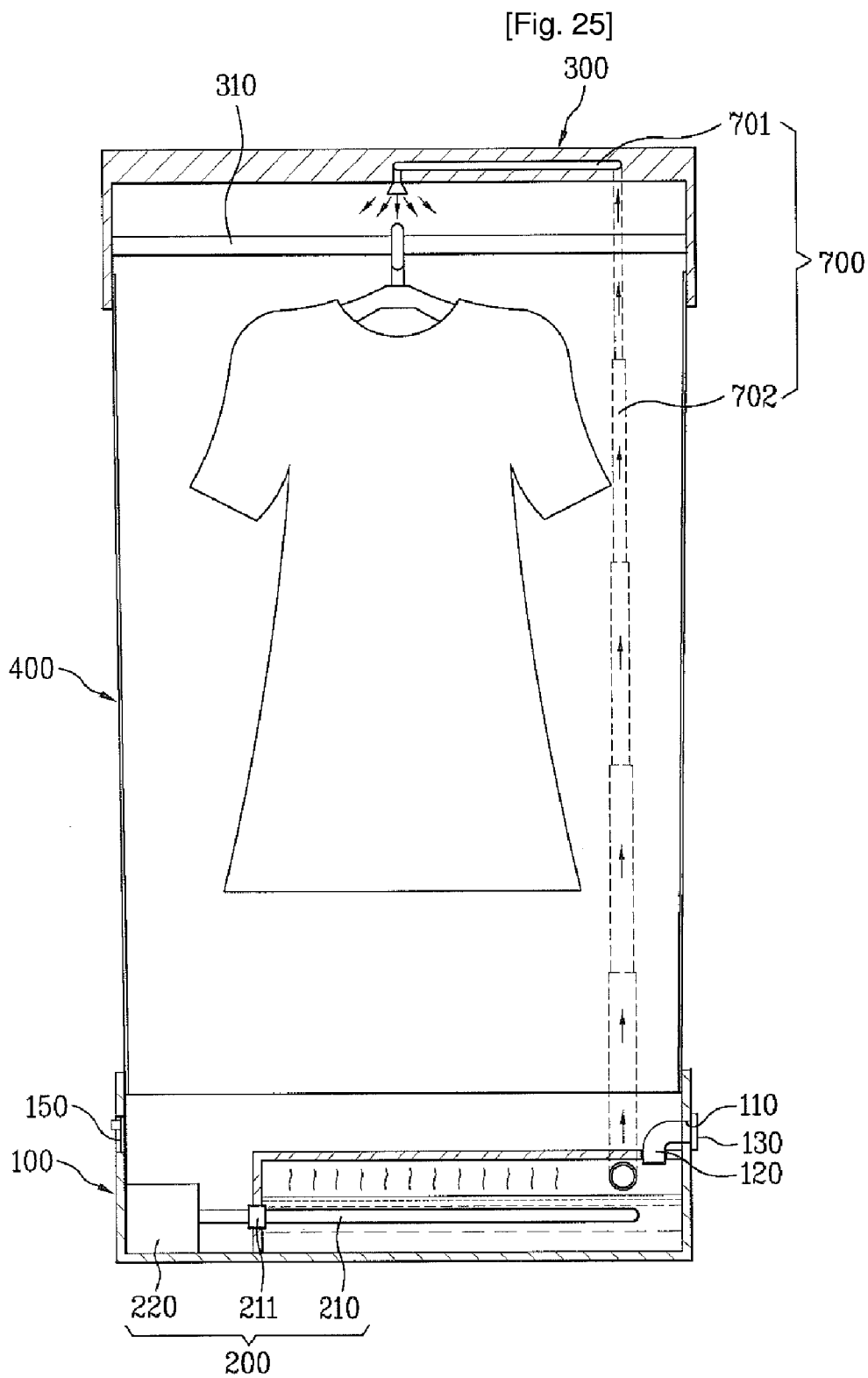



[Fig. 26]

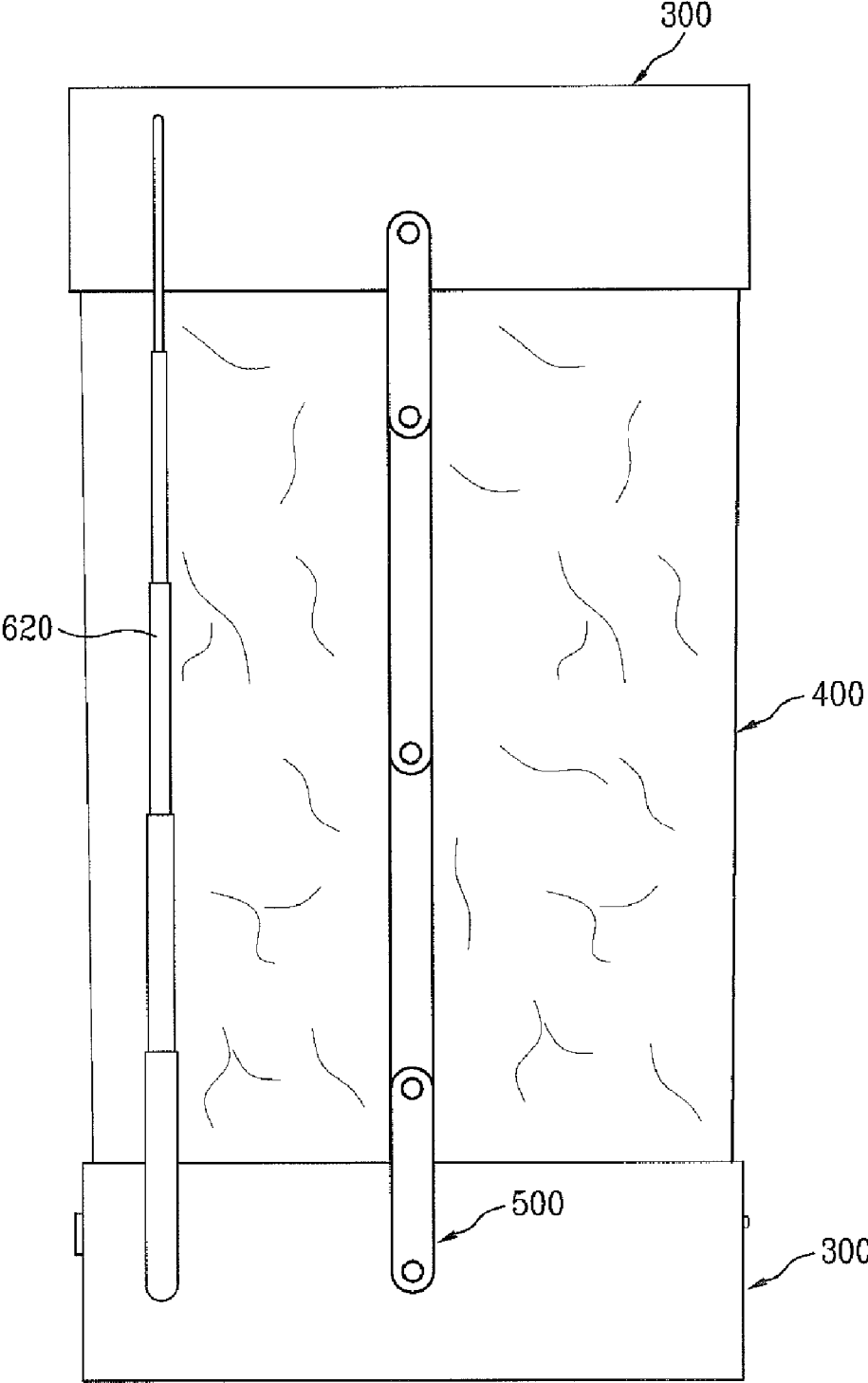

[Fig. 27]

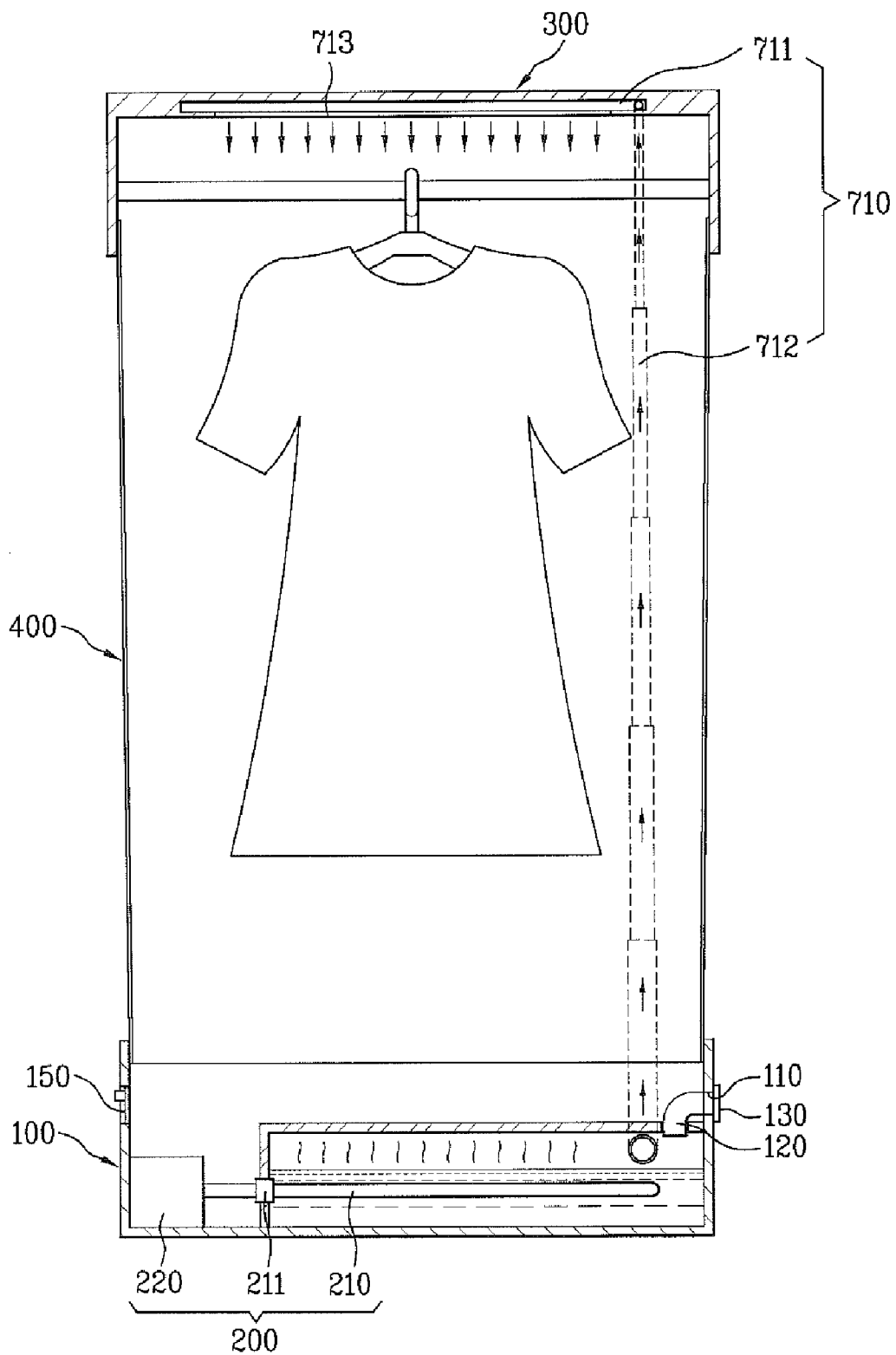

[Fig. 28]

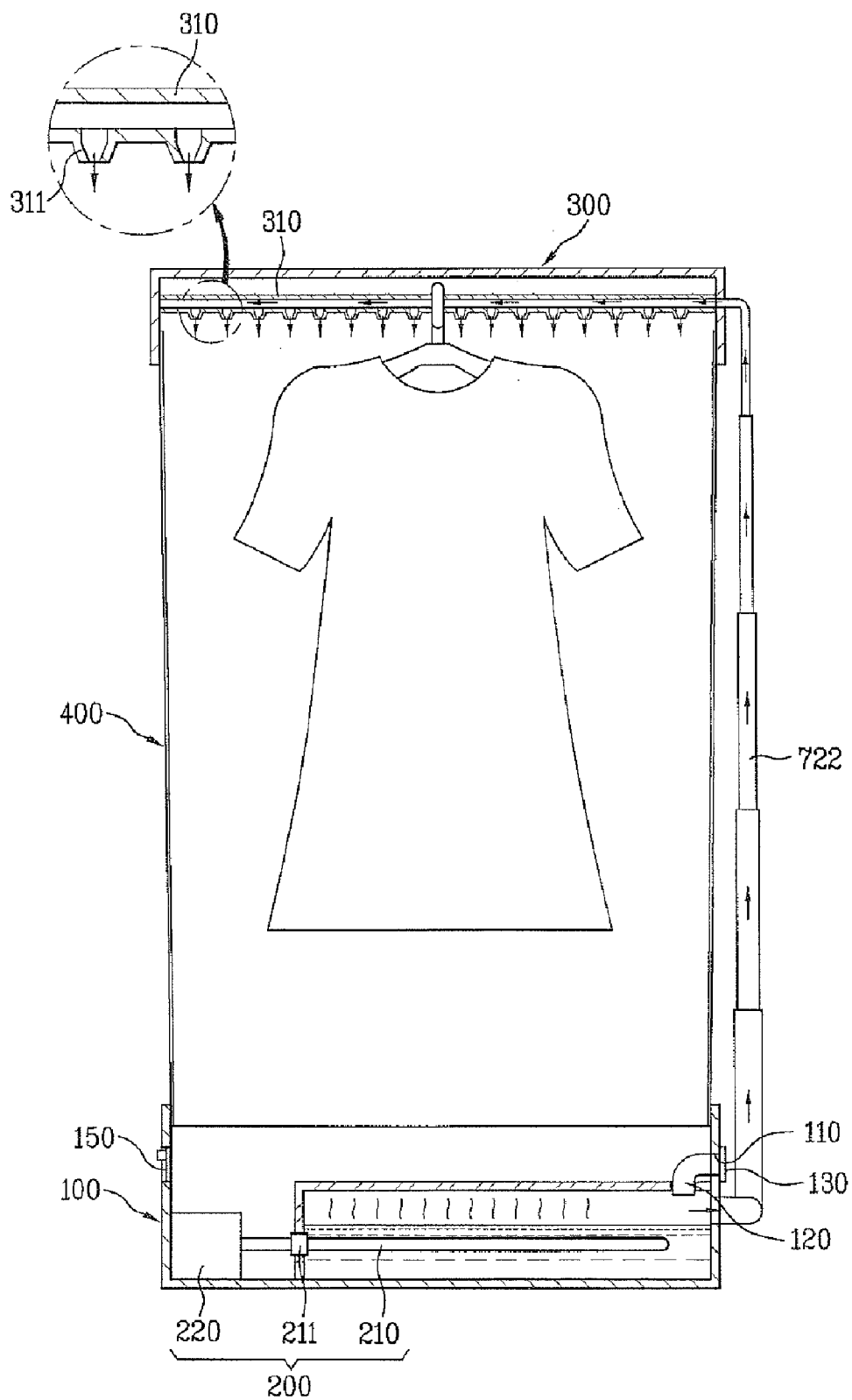

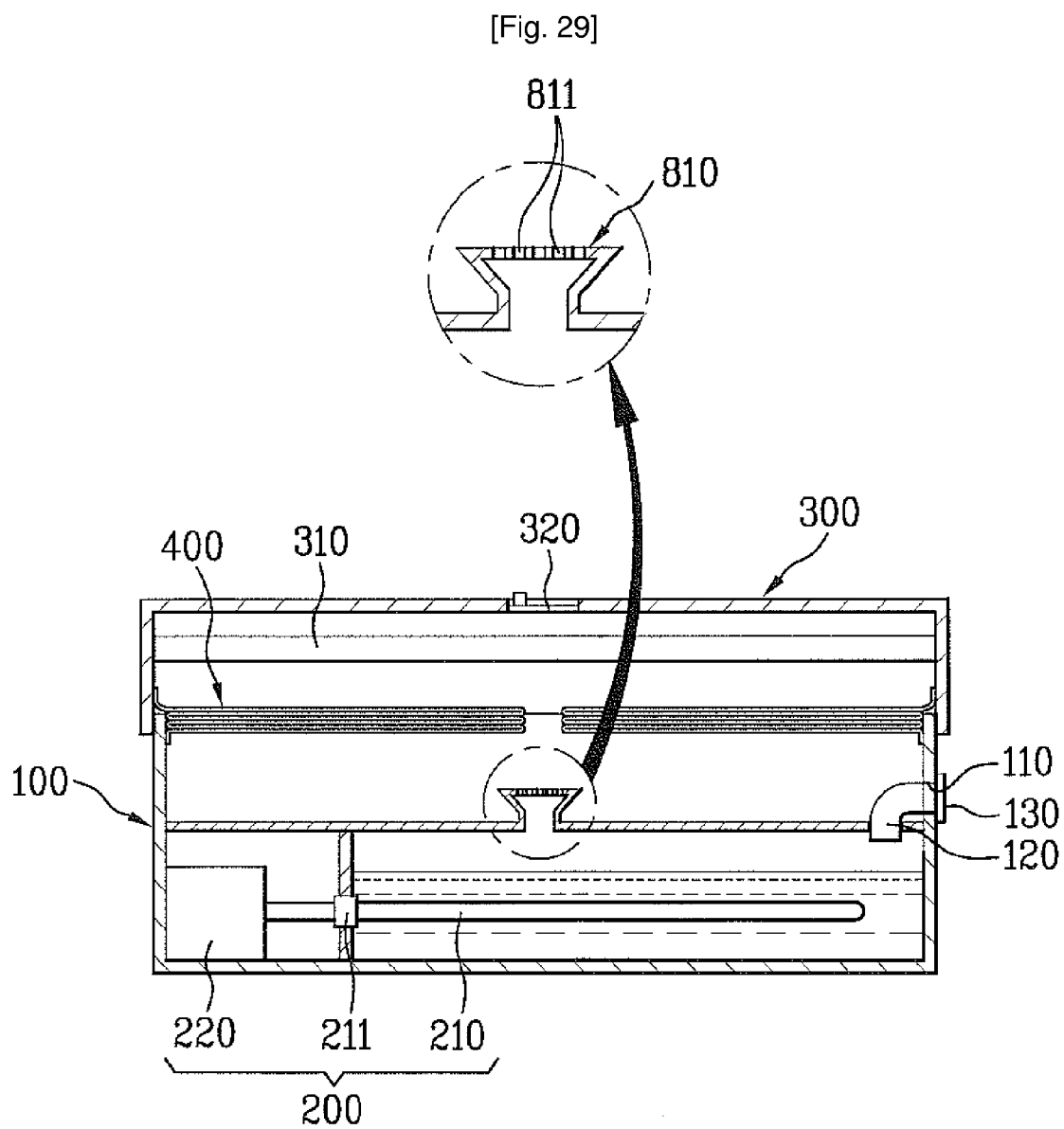

[Fig. 30]

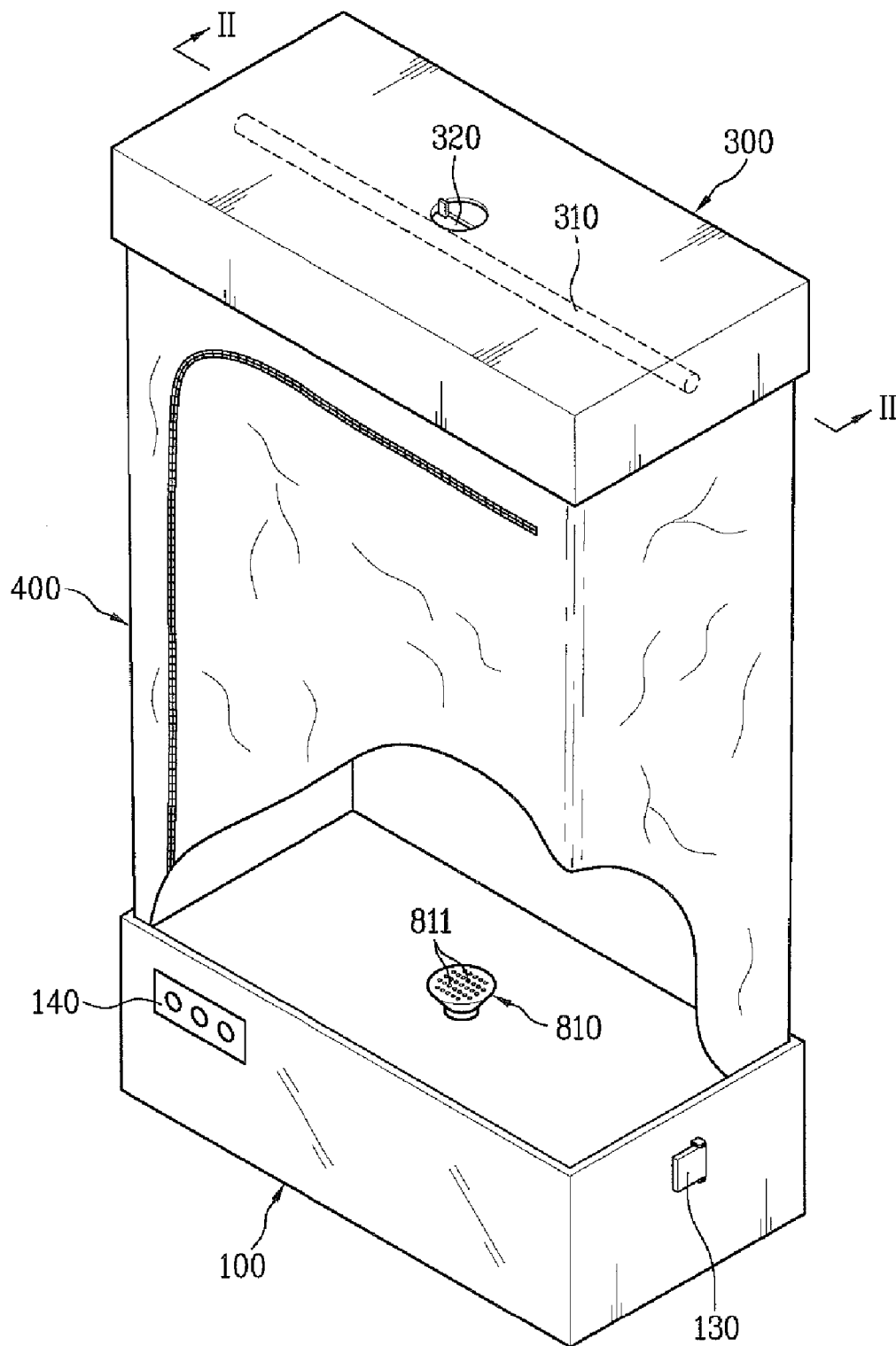

[Fig. 31]

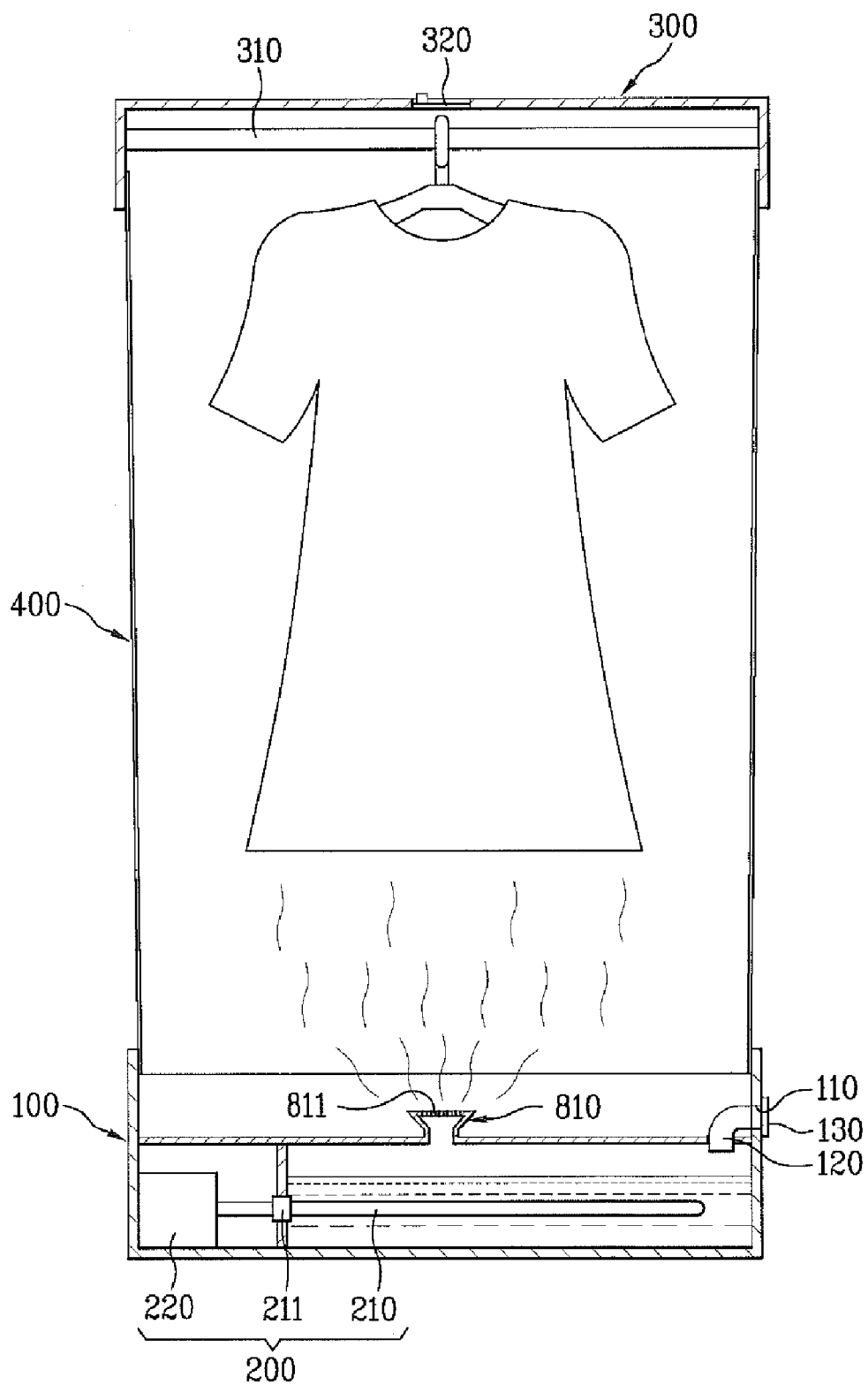

[Fig. 32]

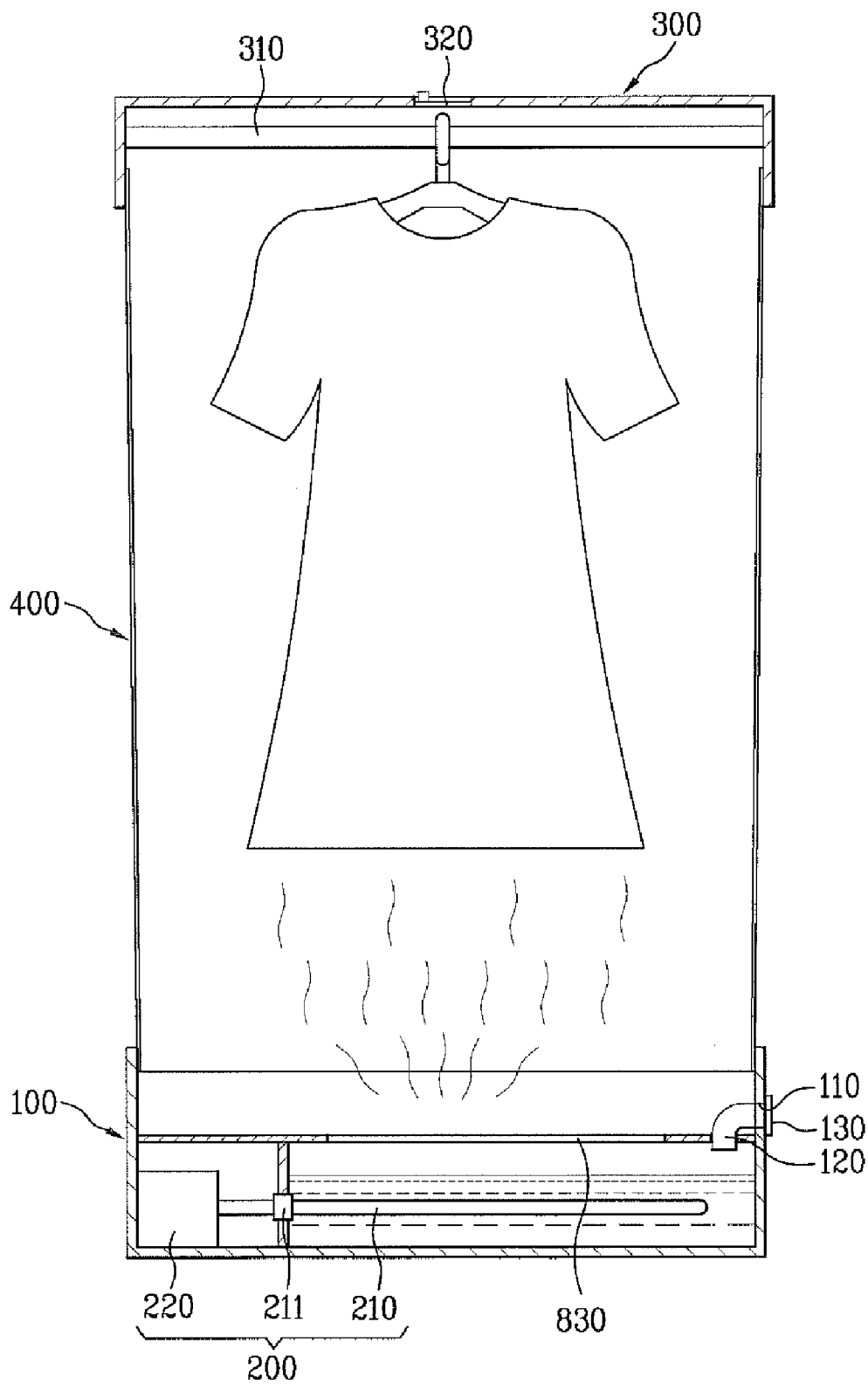

[Fig. 33]

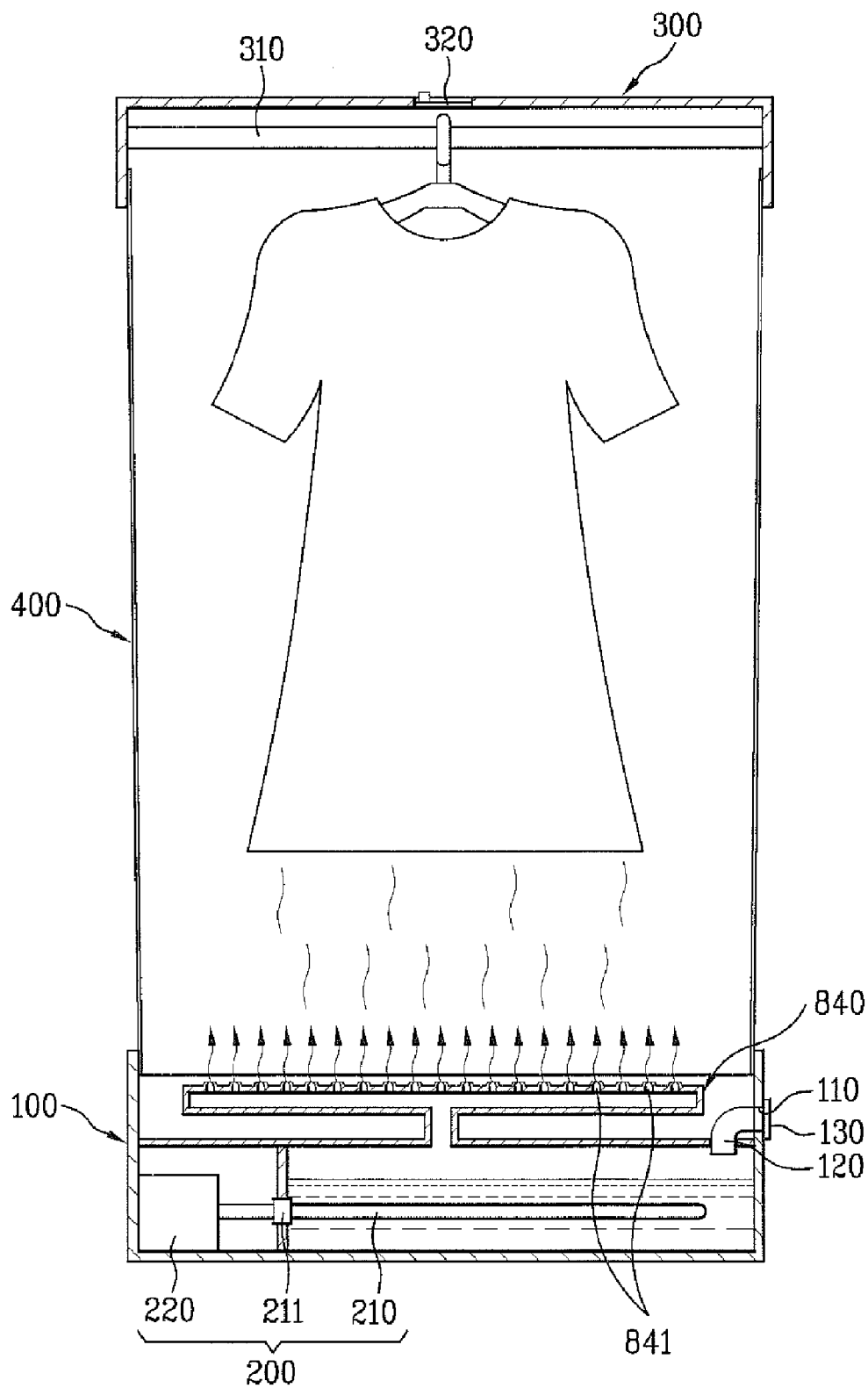



[Fig. 34]

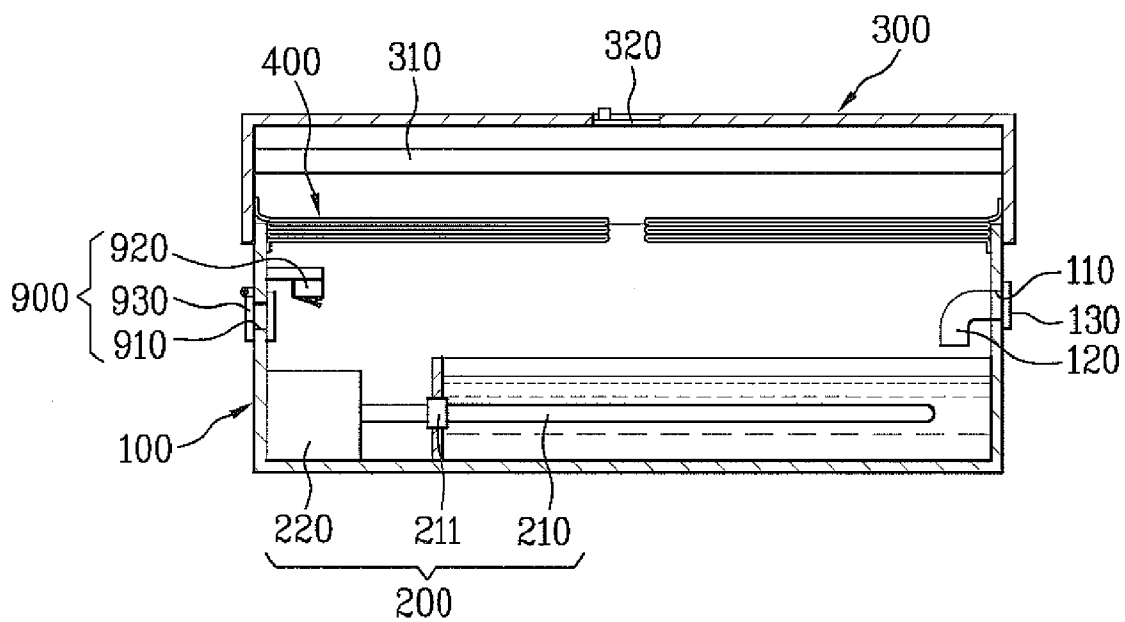

[Fig. 35]

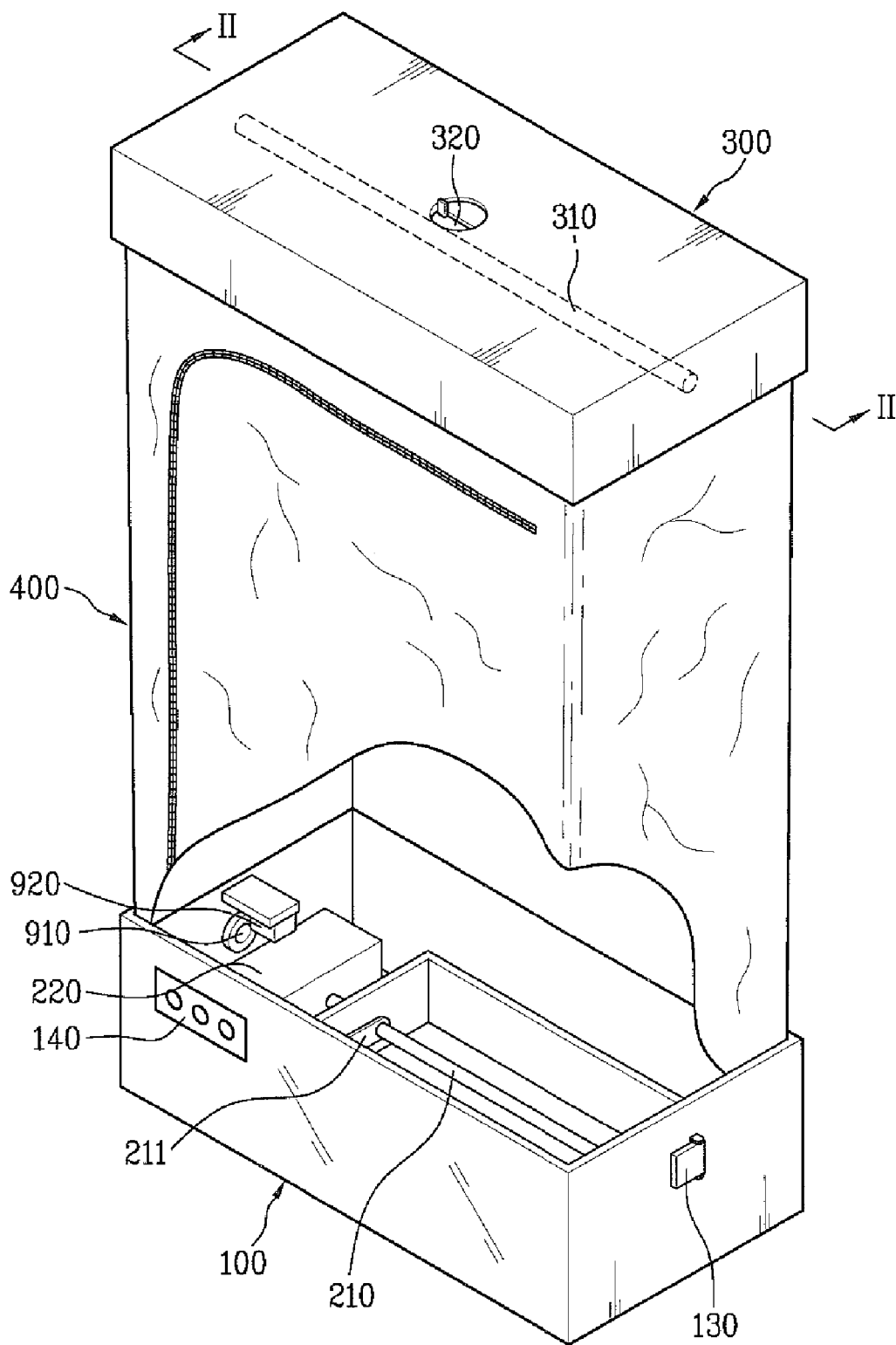

[Fig. 36]

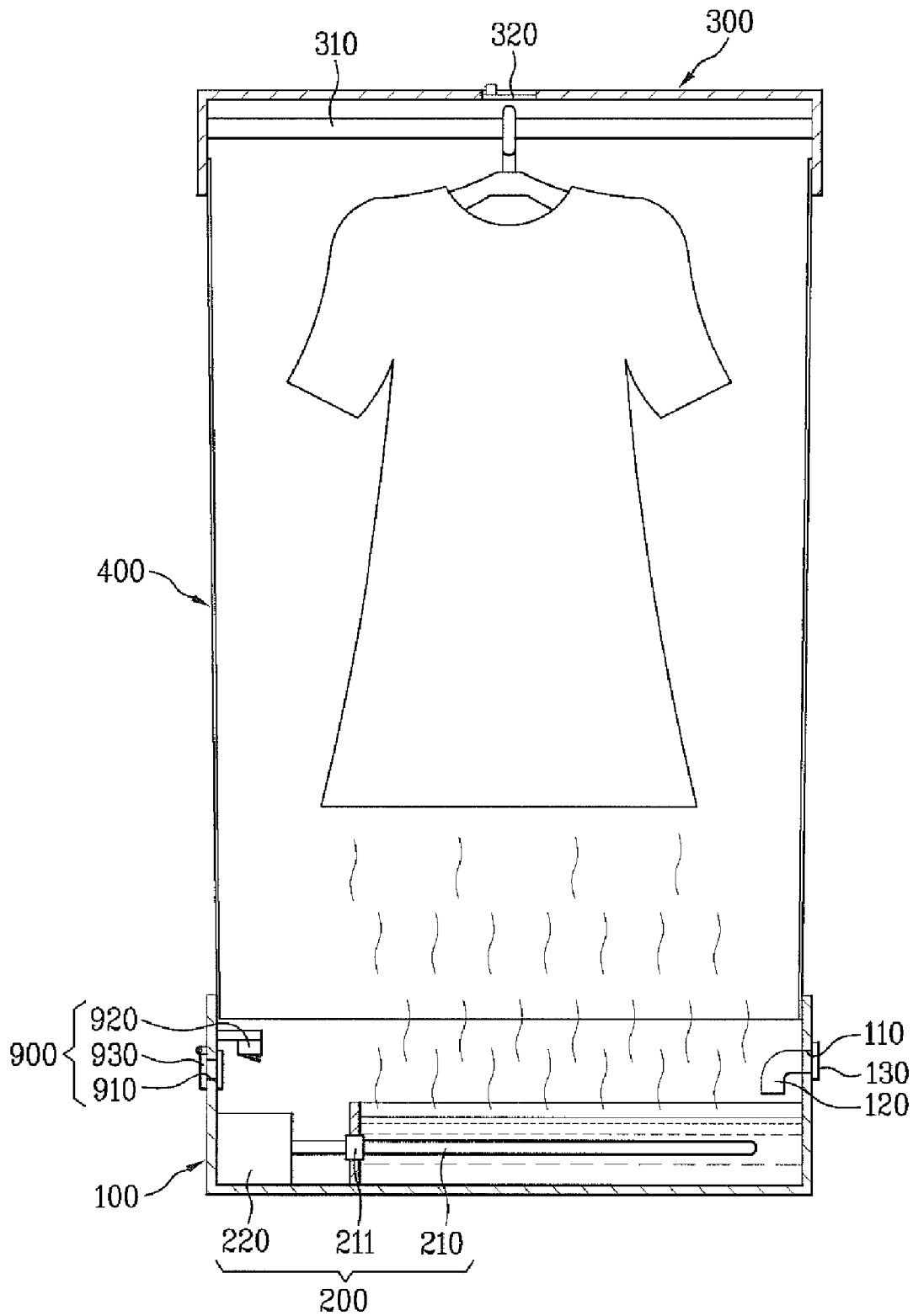

[Fig. 37]

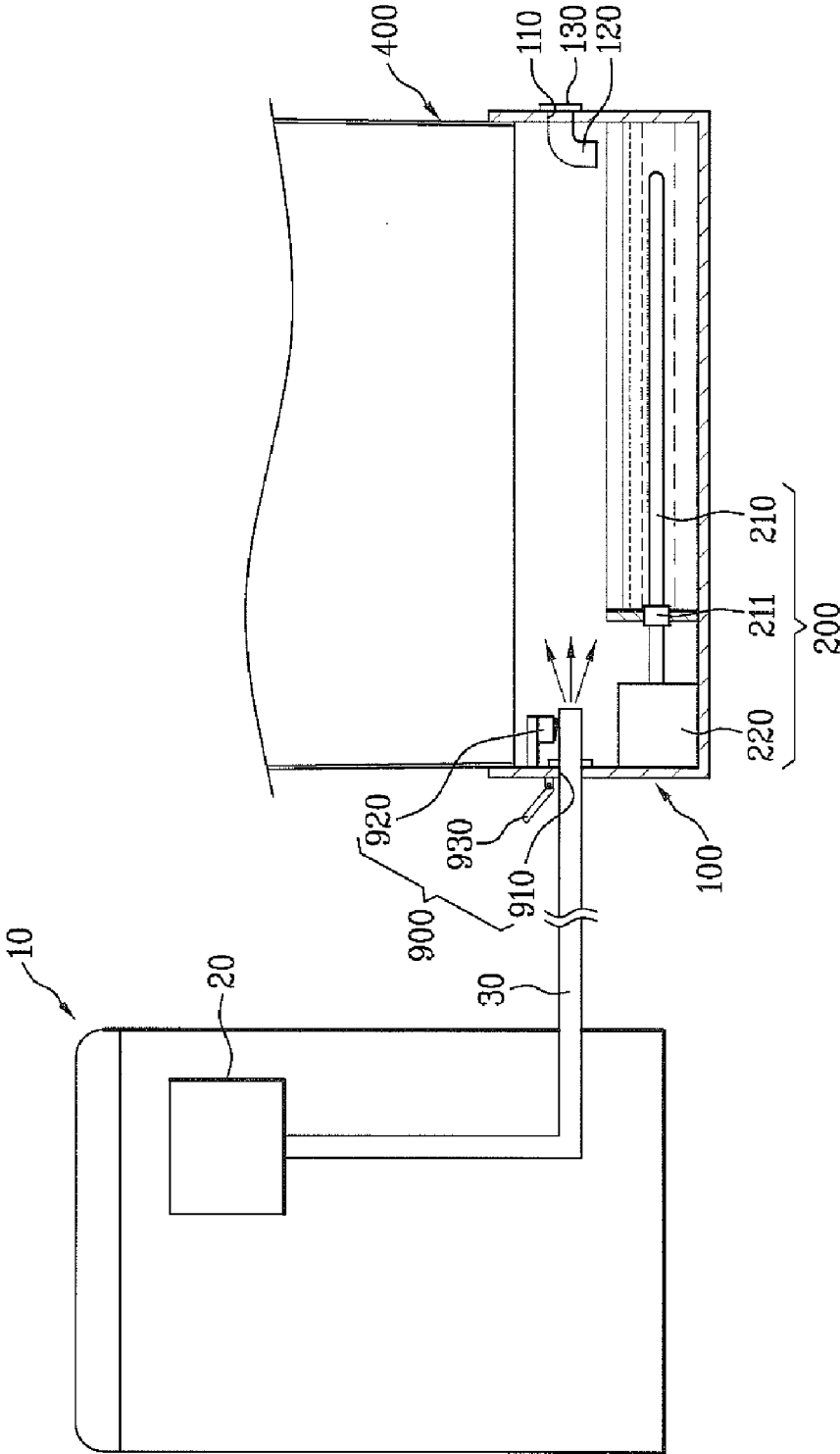

[Fig. 38]

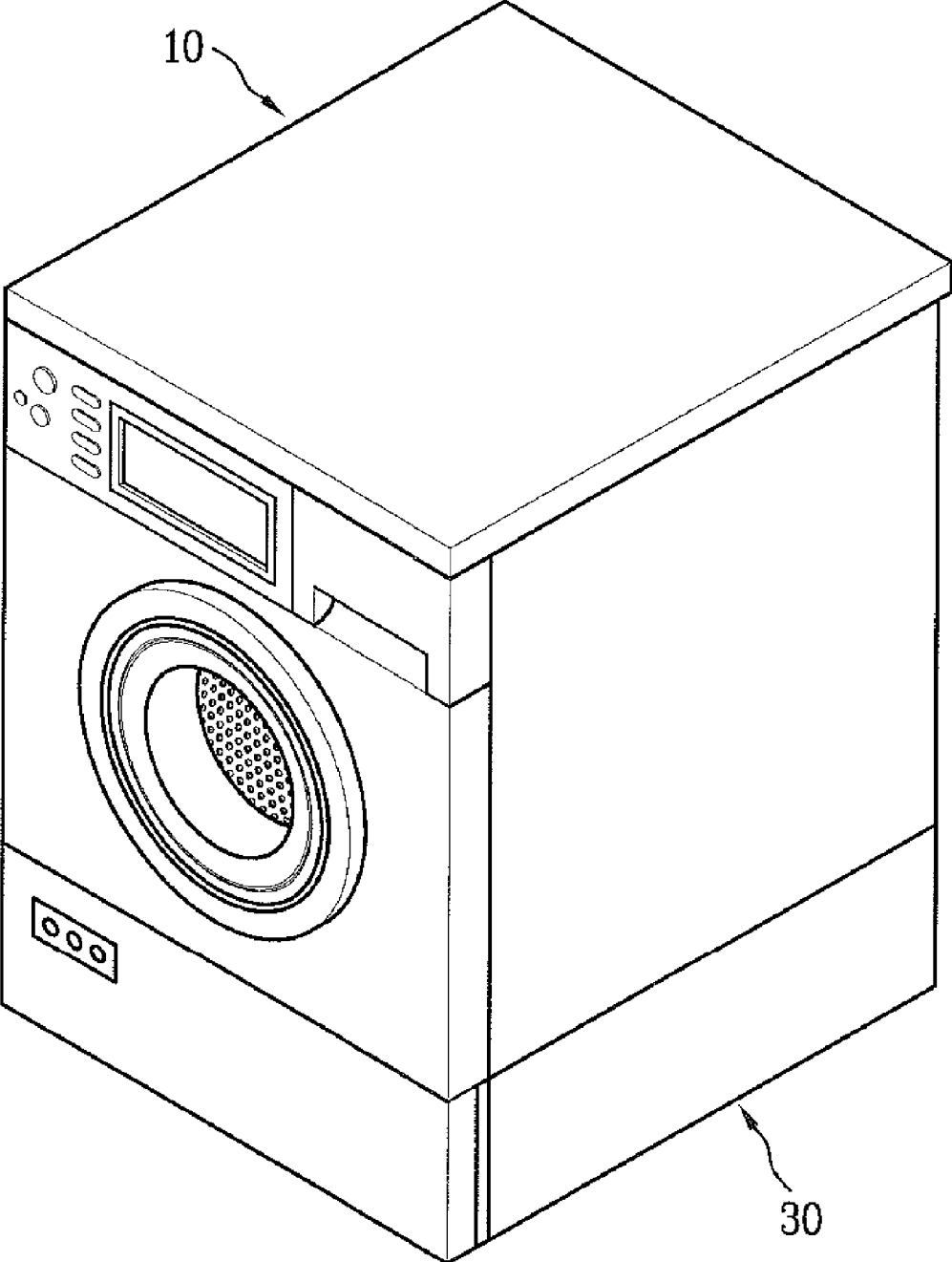

[Fig. 39]

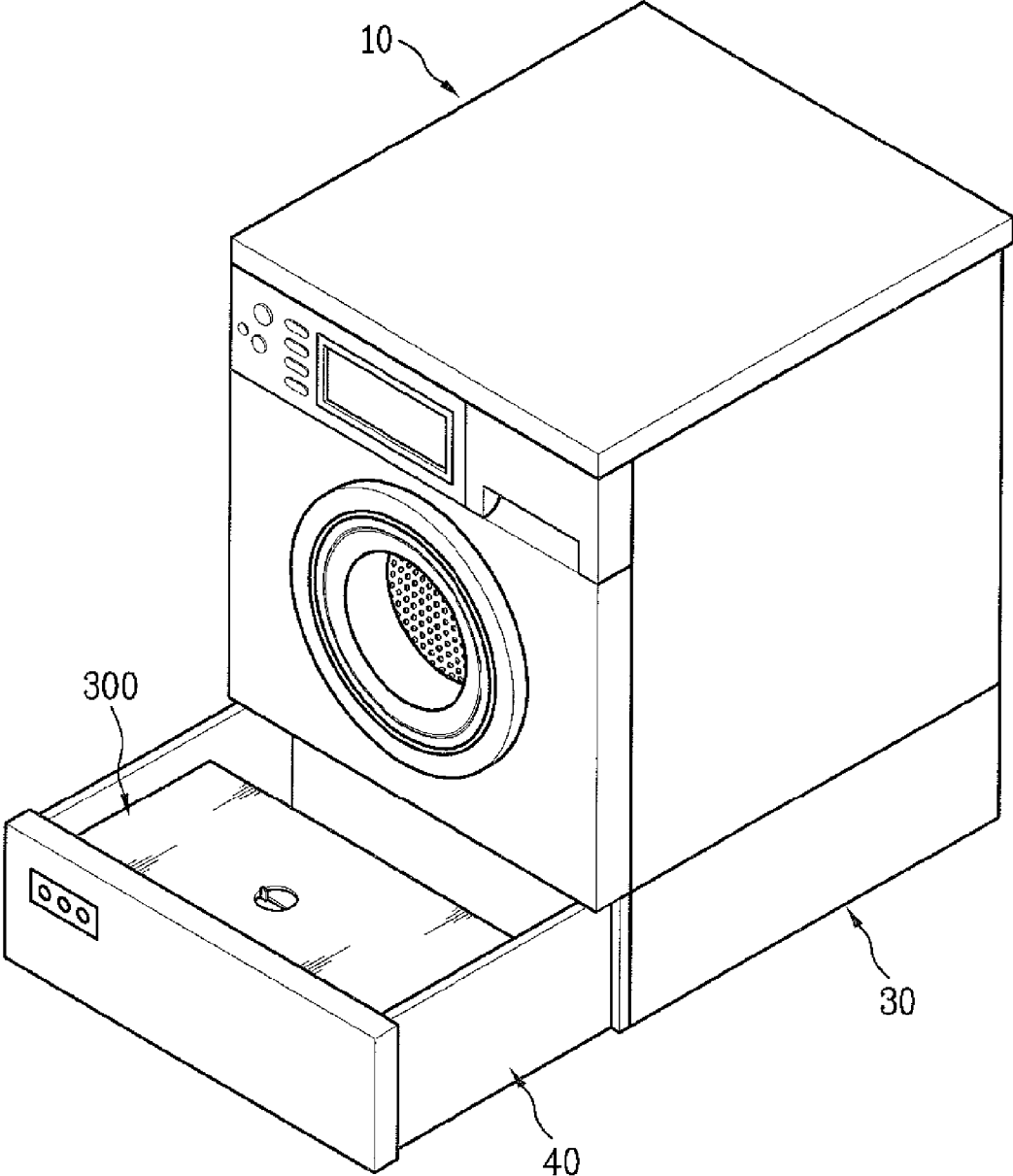

[Fig. 40]

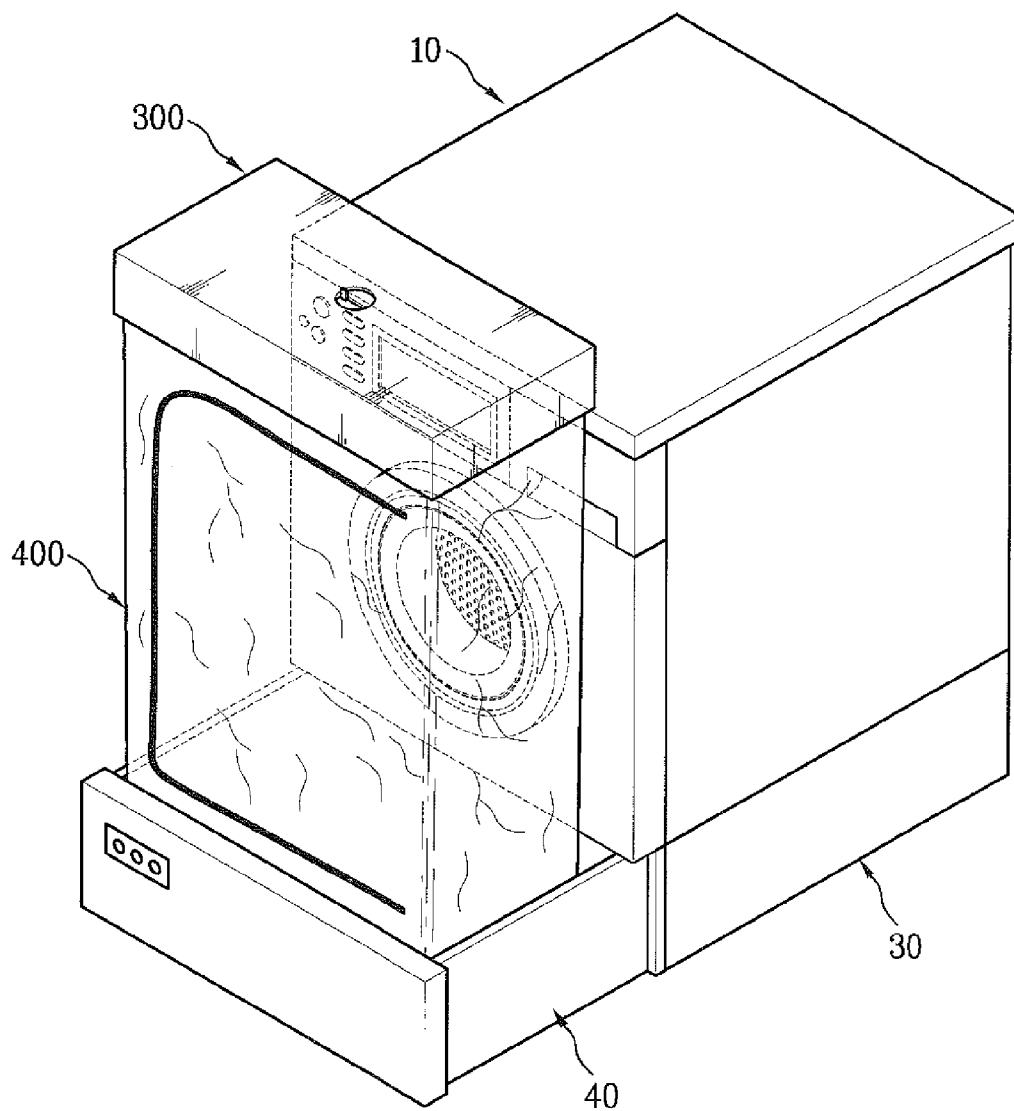

[Fig. 41]

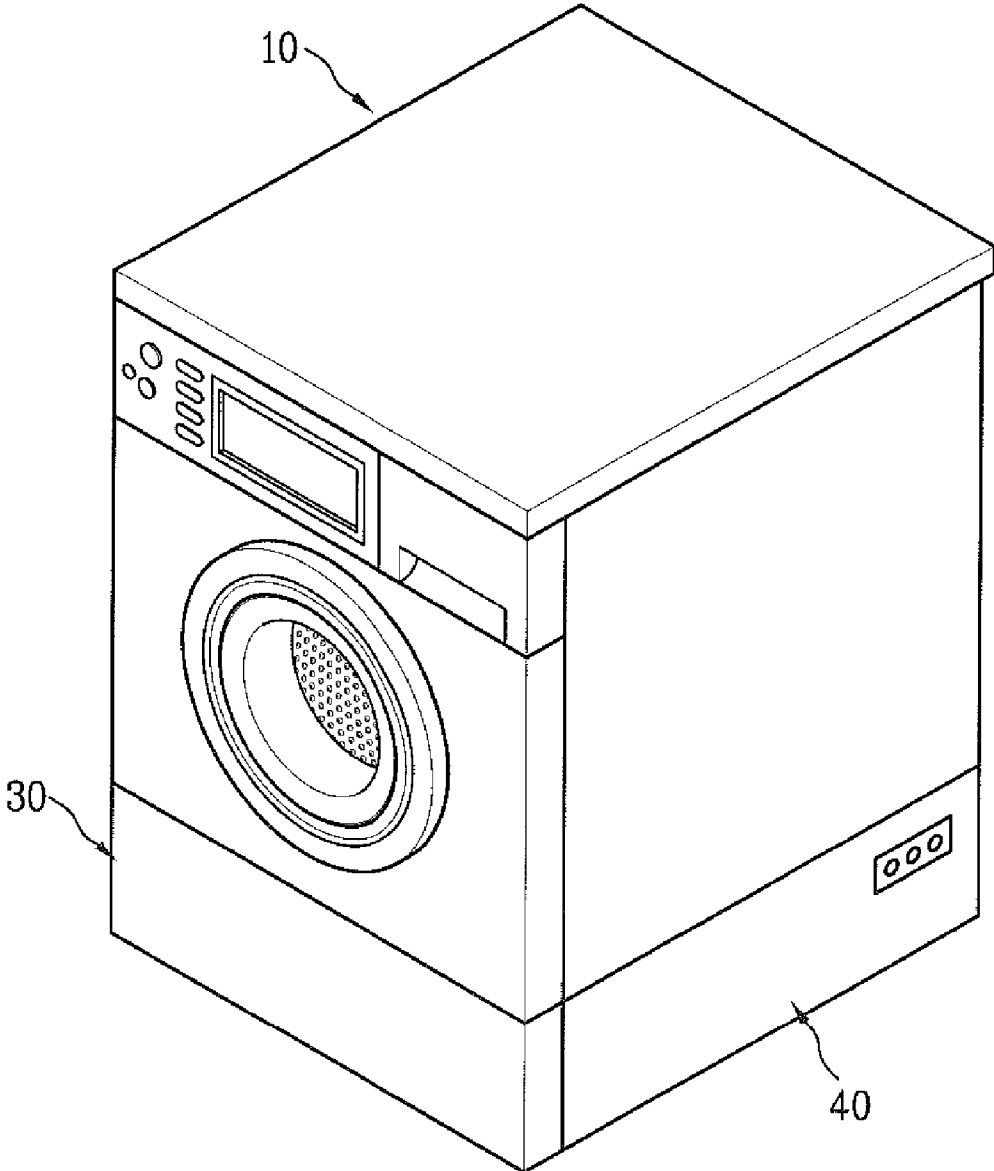



[Fig. 42]

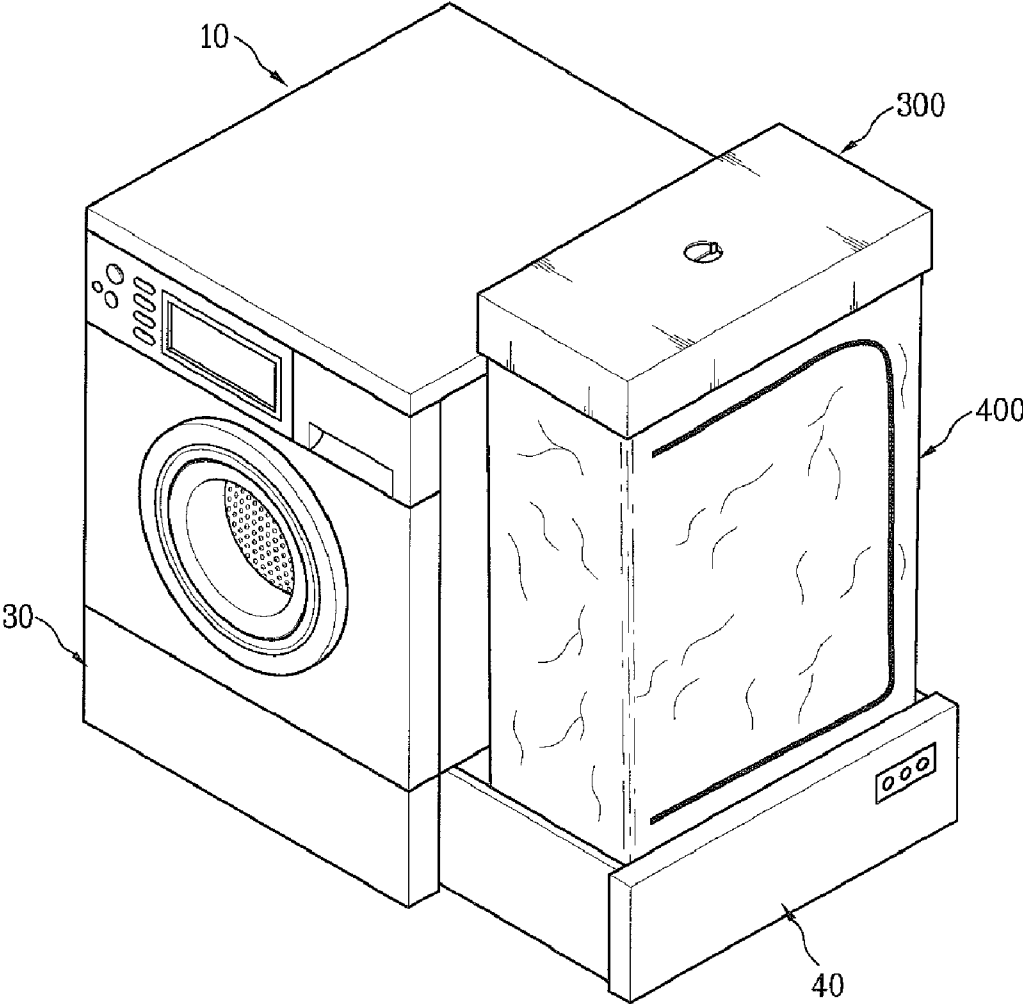

[Fig. 43]

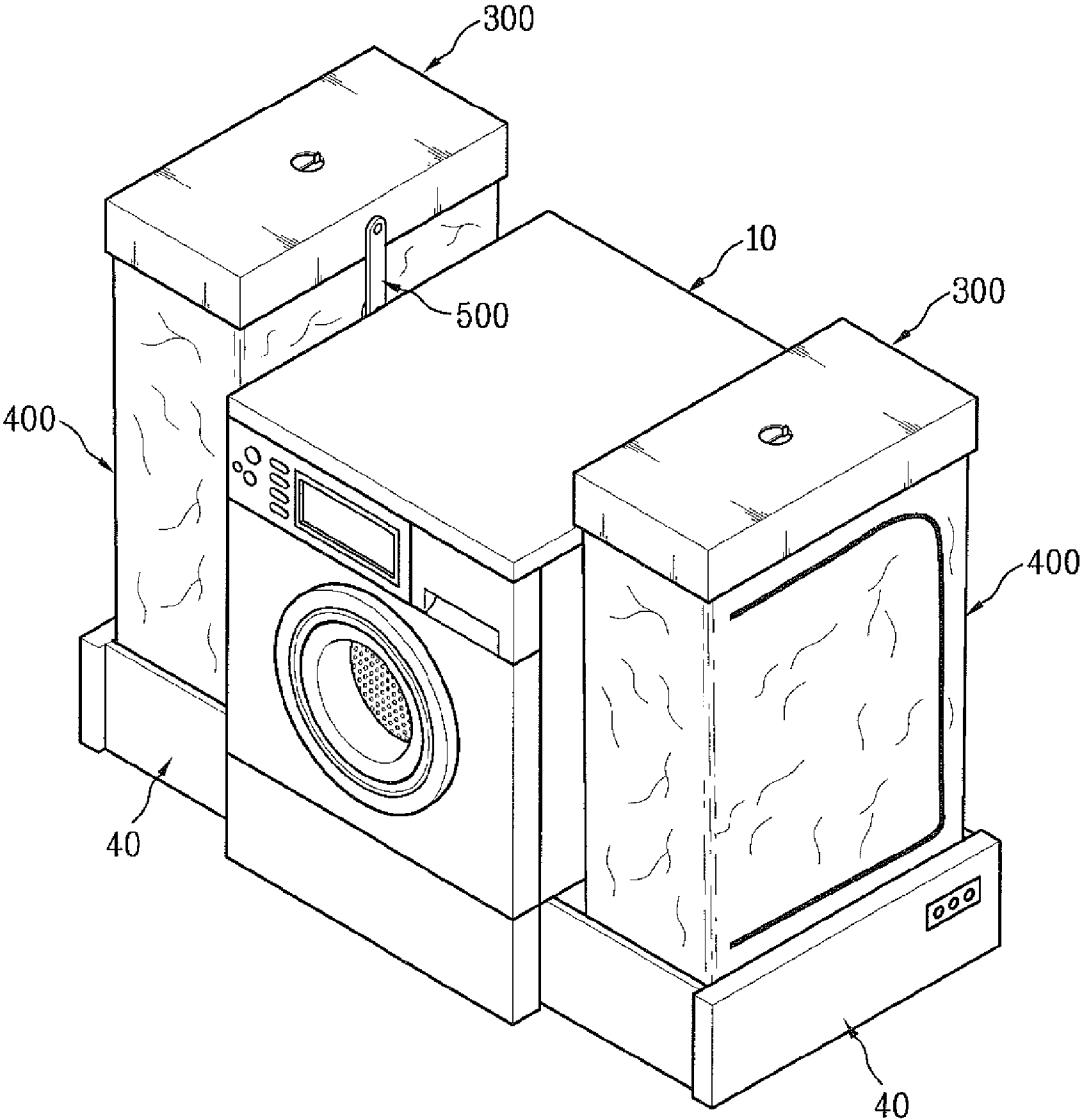

[Fig. 44]

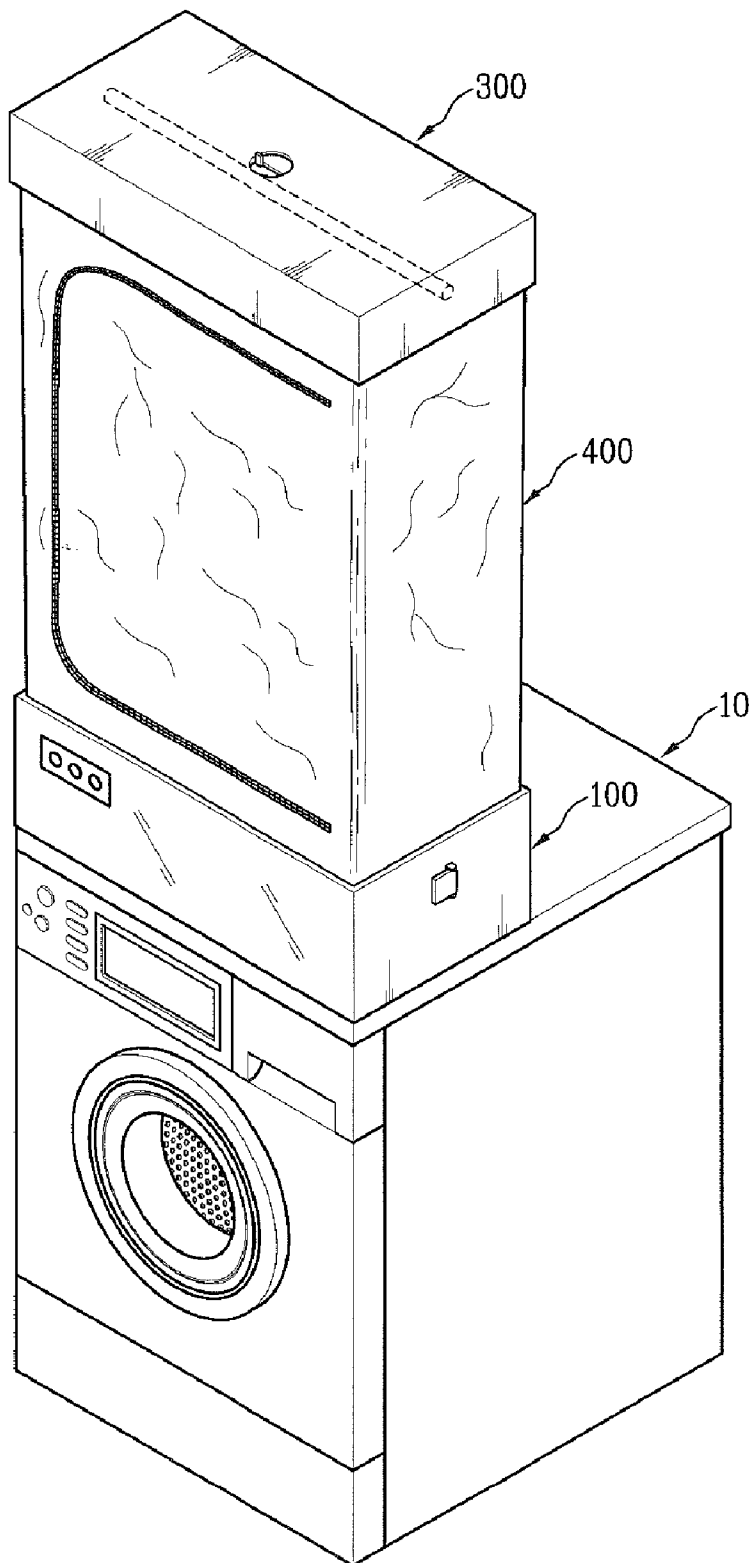

[Fig. 45]

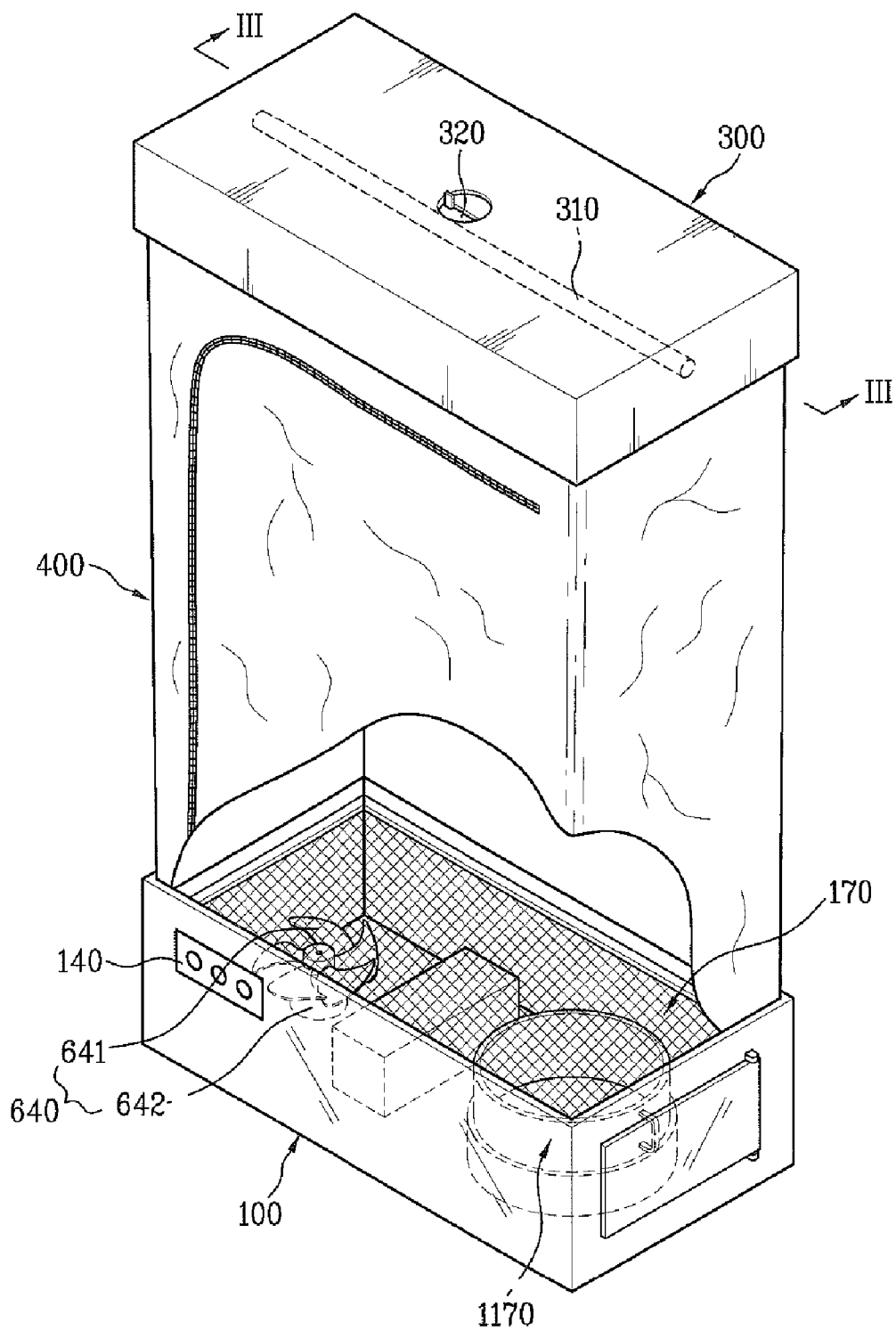

[Fig. 46]

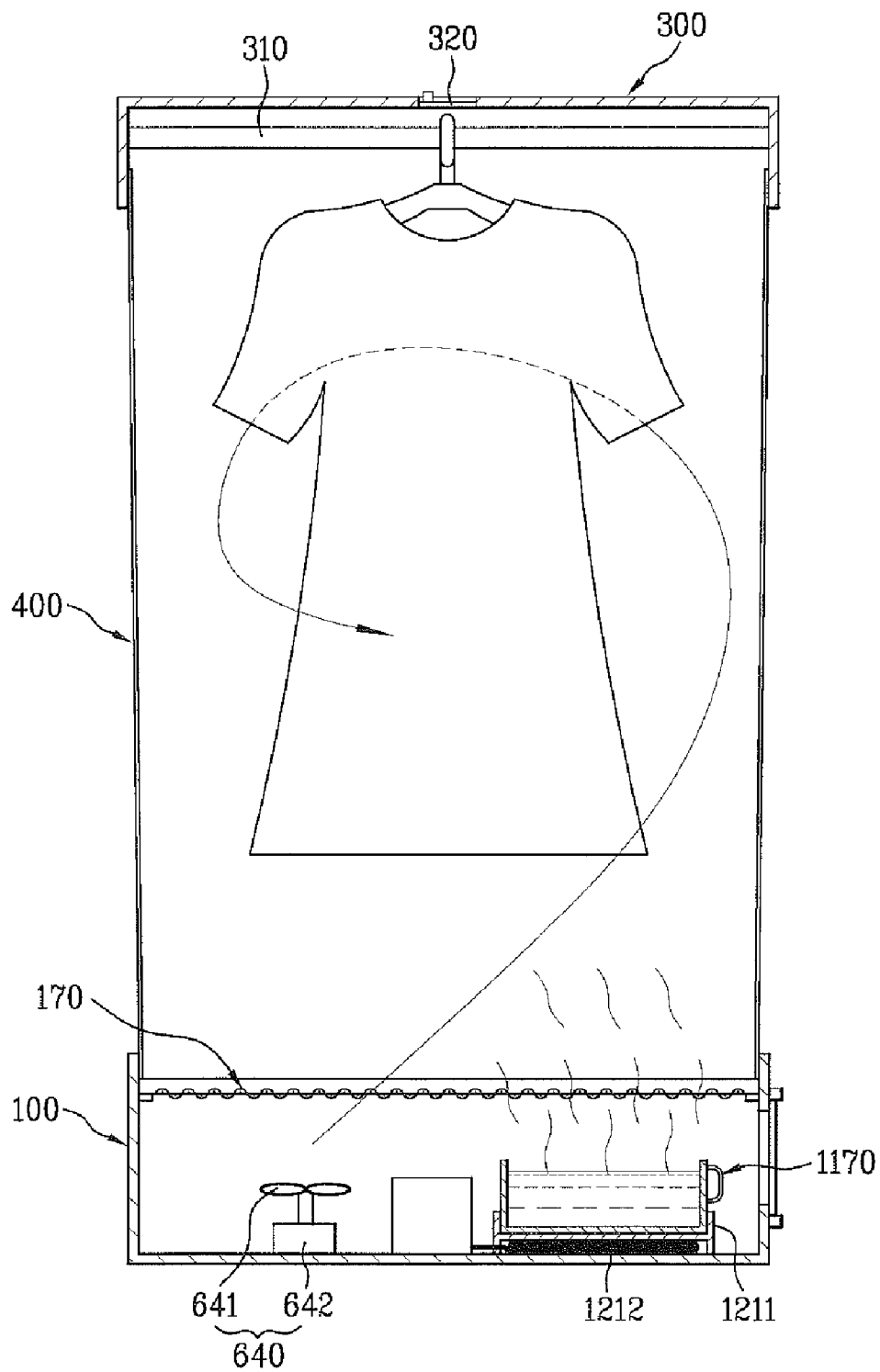

[Fig. 47]

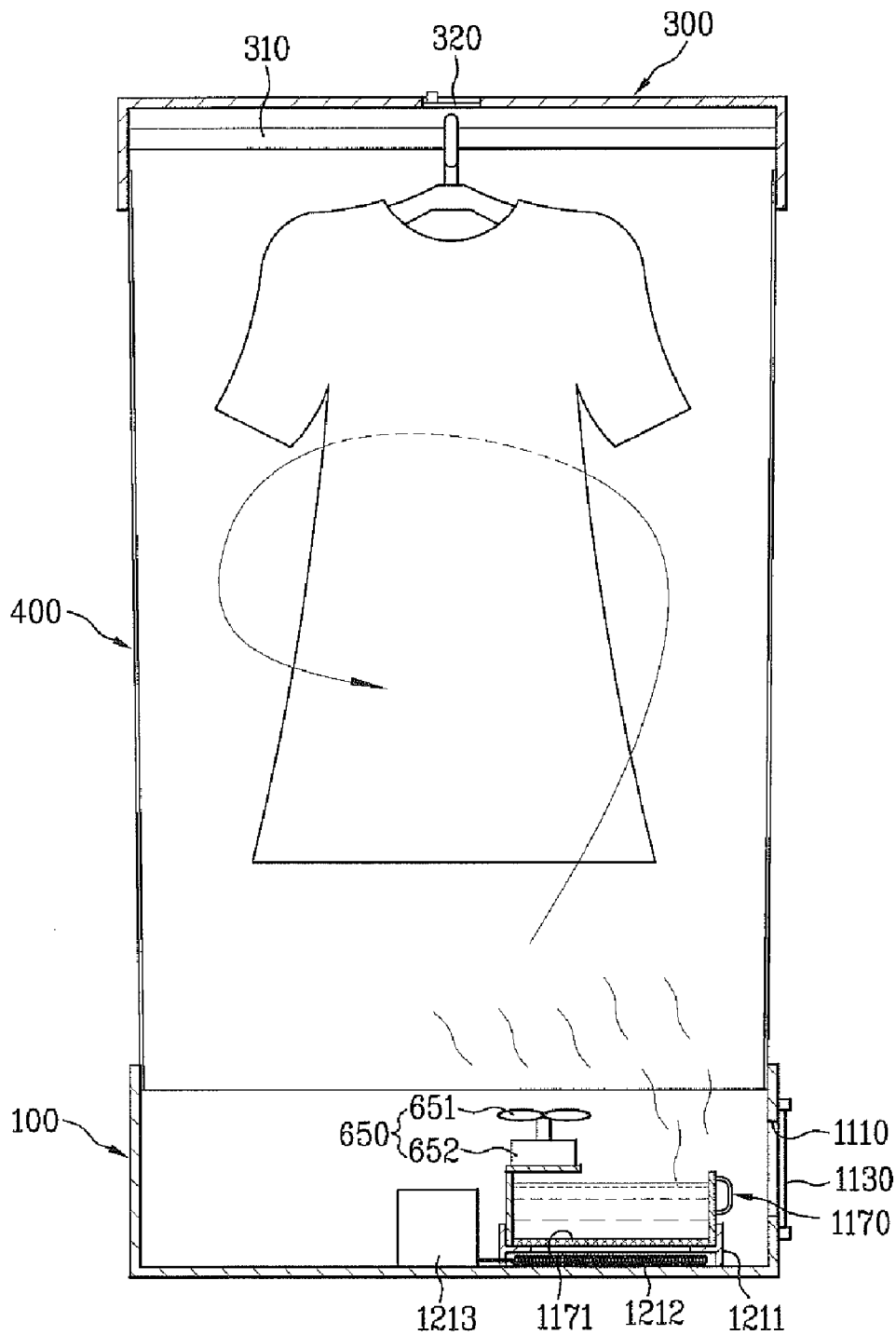

[Fig. 48]

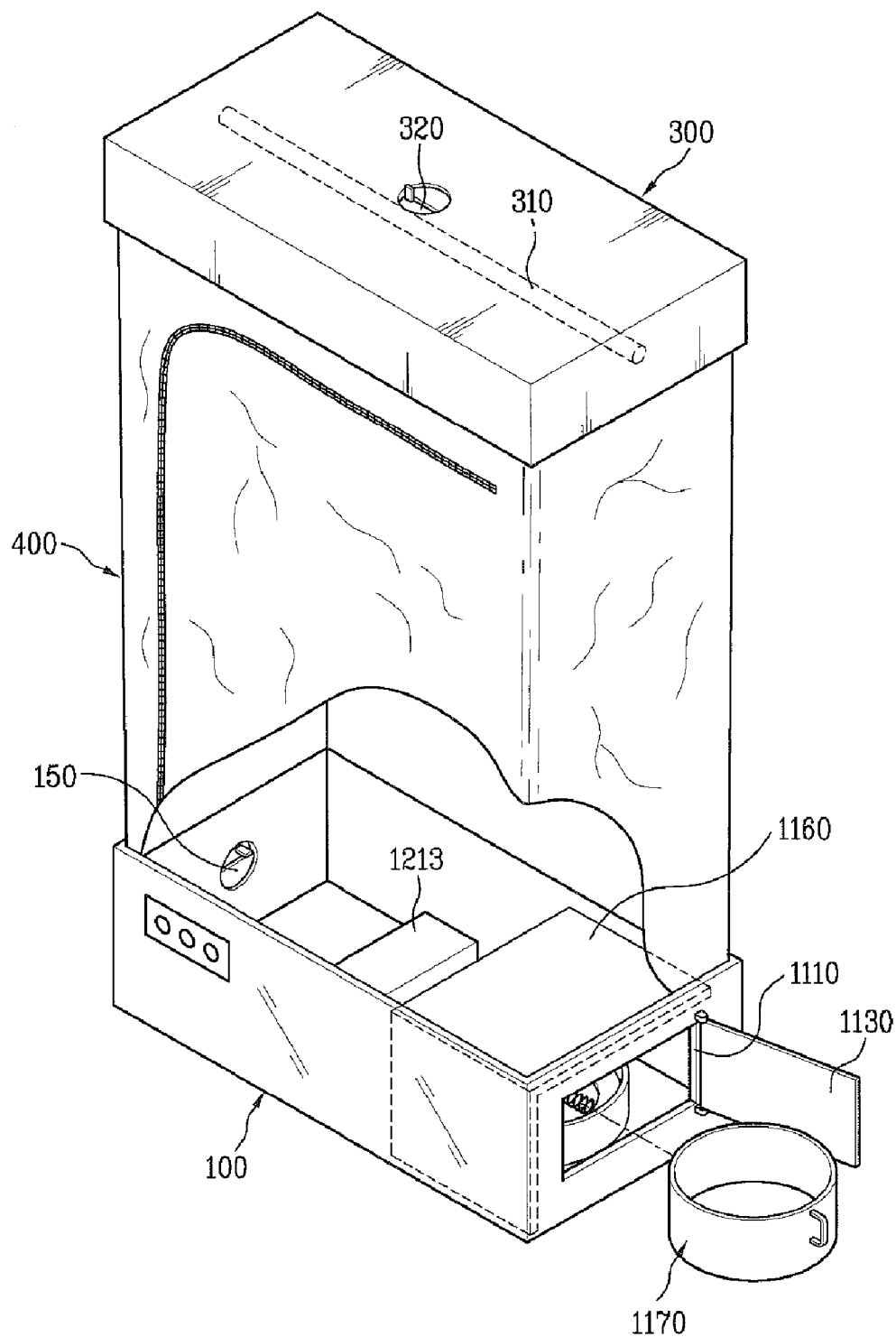

[Fig. 49]

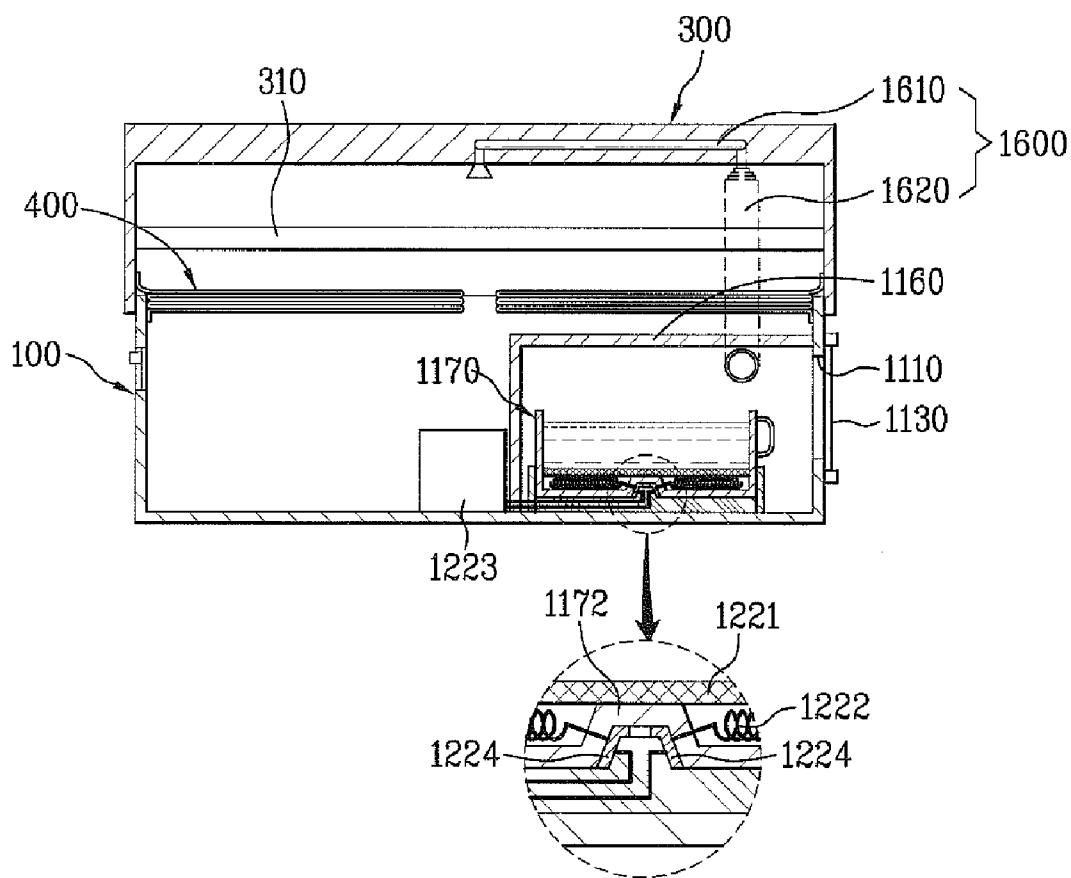



[Fig. 50]

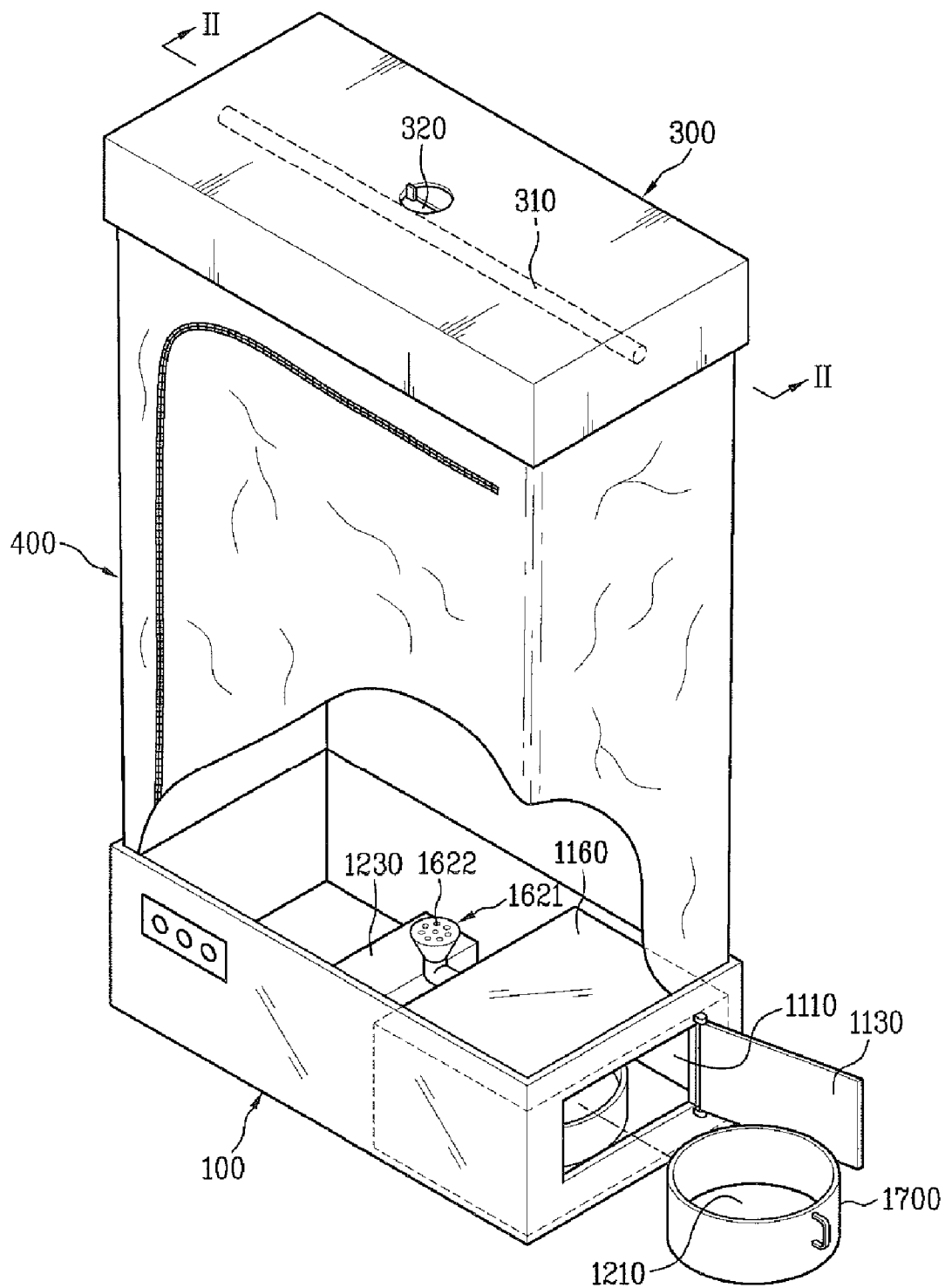

[Fig. 51]

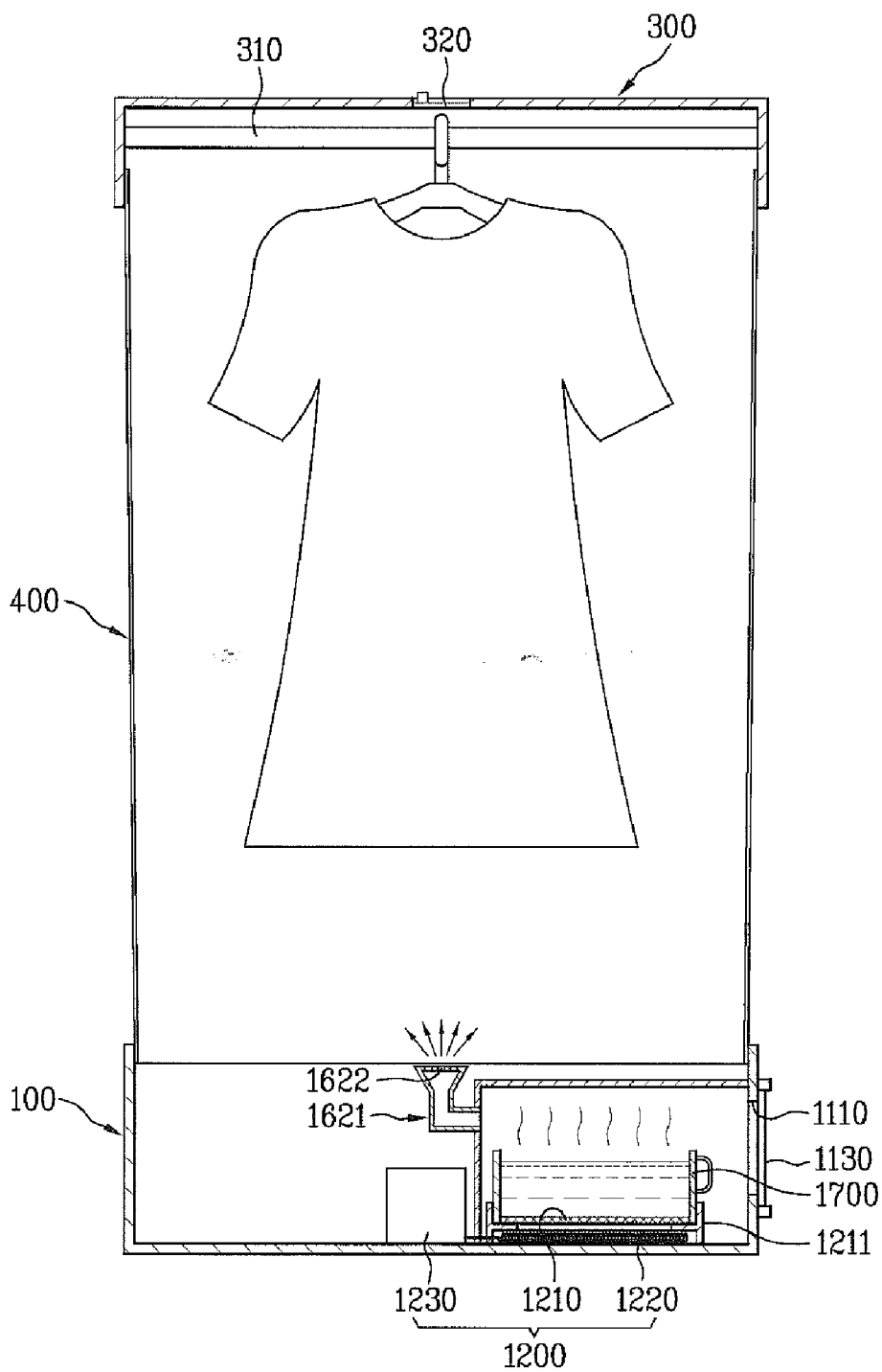

**REFRESHER AND MACHINE FOR WASHING OR DRYING WITH THE SAME**

TECHNICAL FIELD

[0001] The present invention relates to an apparatus for clothes, and more particularly, to a new clothes refresher capable of de-wrinkling and sterilizing clothes.

BACKGROUND ART

[0002] Generally, apparatuses for clothes are designed to perform a variety of operations associated with clothes. Examples of these apparatuses for clothes include a washing machine for washing clothes, a drying machine for drying wet clothes, and other various appliances.

[0003] Among the variety of apparatuses for clothes, the drying machine is adapted to perform a drying operation in a state wherein clothes are put in as one lump, and therefore, has a problem in that entangled portions of the clothes are difficult to be efficiently dried.

[0004] Furthermore, if the dried clothes are left in the drying machine for a long time, wrinkles of the clothes increase and deepen, resulting in a requirement of troublesome ironing. Accordingly, it is impossible to store clothes in the drying machine.

[0005] For these reasons, a recent trend requires a new drying apparatus capable of achieving an increase in drying capacity and enabling long term storage of clothes. U.S. Published Patent Applications Nos. US2004/0194339 A1 and US2004/0154194 A1 disclose dual type drying machines in which a drum type drying machine is provided with a separate drying cabinet.

[0006] The dual type drying machine is a drying appliance configured in such a fashion that the drying cabinet having a space for receiving a variety of clothes is mounted at an upper side of the drum type drying machine having a rotary drum, and the drying cabinet is configured to receive hot air.

[0007] If the hot air is supplied from the drum type drying machine to the drying cabinet, the drying cabinet is used to dry clothes received therein or to enable long term storage of the clothes.

[0008] The above described drying cabinet, however, has a problem in that it must be integrally formed with the drum type drying machine to perform a drying operation.

[0009] This is due to the fact that the drying cabinet can receive hot air only when it is coupled to the drum type drying machine.

[0010] For this reason, it is impossible to use the drying cabinet independently of the drum type drying machine, and the control of the drying cabinet is possible only when the overall power of the dual type drying machine is applied.

[0011] Moreover, the drying cabinet of the above described dual type drying machine has no refresh operation for de-wrinkling and sterilizing clothes, and therefore, is inappropriate for short term storage of clothes.

DISCLOSURE OF INVENTION

Technical Problem

[0012] An object of the present invention devised to solve the problem lies on an apparatus which enables short term storage of clothes and can perform a refresh operation for de-wrinkling and sterilizing the clothes stored.

[0013] Another object of the present invention devised to solve the problem lies on a new refresher which can be used independently based on configuration thereof, and can achieve an improvement in installation and portability thereof.

[0014] A further object of the present invention devised to solve the problem lies on a new refresher which is compatible with a washing apparatus, such as a washing machine or clothes drying machine, and can cooperate with the washing apparatus.

Technical Solution

[0015] The object of the present invention can be achieved by providing a clothes refresher comprising: a body configured to receive clothes therein; and a steam supply device to supply steam into the body in order to supply the steam to the clothes.

[0016] The steam supply device may be a steam generator mounted in the clothes refresher, or may be a separate external device provided at the outside of the refresher. Examples of the external device include a drying machine or washing machine having a steam generator.

[0017] When the steam supply device is included in the refresher, the clothes refresher may comprise a base having a water storage space; a body configured to receive clothes therein; and a steam generator to heat water stored in the base to generate steam, in order to supply the steam to the clothes received in the body.

[0018] Preferably, the clothes refresher may further comprise a cover to cover the base, and the body may have a foldable structure to be received inside the cover and the base in a folded state.

[0019] Preferably, the base may have an inlet opening to supply water from an external source into the water storage space, and a passage extending from the inlet opening to the water storage space. Here, the inlet opening may be provided with an opening/closing door for opening and closing thereof.

[0020] The steam generator may include: a heat-radiating heater mounted in the water storage space of the base; and a controller to control the heat-radiating heater.

[0021] Preferably, the cover may be provided with a holder bar for hanging the clothes thereon. Preferably, the cover may be formed with an outlet opening to discharge air or steam.

[0022] Preferably, the body may be formed with a zipper for putting the clothes into the body and taking out the clothes from the body in a simplified manner. Preferably, the body may be made of a flexible material, and the zipper is used to open the inner space of the body.

[0023] Preferably, the base may be provided with a partition placed above the water storage space. The partition serves to separate the inner space of the base from the inner space of the body, to prevent the clothes received in the body from dropping into the base even if the clothes are carelessly dropped from the holder bar. In this case, the partition may be formed with a plurality of injection nozzles.

[0024] Preferably, the partition has a lattice form to supply the steam generated in the steam generator of the base to the inner space of the body without requiring a separate structure.

[0025] Preferably, the clothes refresher may further comprise a steam supply pipe connected between the water storage space and the cover to be extendible and contractible in length, and adapted to transfer the steam generated in the water storage space to the clothes received in the body.

**[0026]** The length of the steam supply pipe may be automatically extended and contracted in accordance with upward and downward movements of the cover, or may be manually regulated. Such a regulation in length enables the supply of steam to a desired region inside the body. For example, when the clothes are short, the length of the steam supply pipe is regulated to reach a height where the clothes are located, to achieve efficient supply of steam.

**[0027]** The clothes refresher may further comprise a blowing device to circulate internal air. The blowing device may include an axial flow fan to suck and discharge air in an axial direction, or may include a centrifugal fan to suck air in an axial direction and to discharge the air in a radial direction.

**[0028]** The blowing device may be mounted in the base. Preferably, the blowing device is mounted such that an axial discharge direction thereof faces the water storage space.

**[0029]** The blowing device may be mounted at the cover. Preferably, the blowing device is mounted at the outlet opening formed at the cover. In this case, the blowing device allows the internal air of the body to be efficiently discharged to the outside, to thereby facilitate the circulation of air inside the body.

**[0030]** The clothes refresher may further comprise a steam injection device to inject the steam generated by the steam generator to the inner space of the body.

**[0031]** In particular, the steam injection device may be an upper steam injection device to inject the steam into an upper space of the body, or a lower steam injection device to inject the steam into a lower space of the body.

**[0032]** The upper steam injection device may include: a steam injection pipe provided at the cover and having a steam injector; and a steam supply pipe having one end communicating with the steam injection pipe and the other end communicating with the water storage space of the base, the steam supply pipe being extendible and contractible in length.

**[0033]** The length of the steam supply pipe may be automatically extended and contracted in accordance with upward and downward movements of the cover, or may be manually regulated. Such a regulation in length enables the supply of steam to a desired region inside the body. For example, when the clothes are short, the length of the steam supply pipe is regulated to reach a height where the clothes are located, to achieve efficient supply of steam.

**[0034]** The steam supply pipe may be detachably connected to the steam injection pipe. In a state wherein the steam supply pipe is connected to the steam injection pipe, the steam is supplied into the upper space of the body. Conversely, in a state wherein the steam supply pipe is separated from the steam injection pipe, the steam is supplied to a region where a distal end of the steam supply pipe is located.

**[0035]** Preferably, the steam injection pipe may take the form of a holder bar for hanging the clothes thereon. Since the steam is supplied to a region right above the clothes hung on the holder bar, a refresh operation of the clothes can be efficiently accomplished.

**[0036]** The lower steam injection device may include a steam injection pipe mounted at the partition that separates the water storage space of the base from the body. The steam injection pipe may have a steam injector to inject the steam generated in the water storage space to the inner space of the body.

**[0037]** When the partition is included in the clothes refresher, the lower steam injection device may take the form of an elongated slot formed at the partition. Alternatively, the

lower steam injection device may include a steam injection arm having a plurality of steam injection holes and placed longitudinally above the partition by a long length.

**[0038]** The clothes refresher may be formed with a connection opening for the connection of a steam flow pipe, to receive steam supplied from an external source through the steam flow pipe.

**[0039]** Here, the external source for supplying steam may be a drying machine or washing machine having a steam generator.

**[0040]** Preferably, the connection opening may be formed at the base or the cover.

**[0041]** Preferably, the clothes refresher may be provided with a sensor for sensing the connection or separation of the steam flow pipe, such that the steam generator mounted therein is appropriately controlled based on the connection or separation of the steam flow pipe.

**[0042]** The base may include a water container for storing water therein. The water container may be detachably mounted in the water storage space.

**[0043]** In this case, the steam generator may include: an electric heating coil to heat the water container in order to generate steam; and a controller to control the electric heating coil.

**[0044]** Preferably, the base may be formed with a closable mounting opening to put or take out the water container into or from the base.

**[0045]** The electric heating coil may be mounted at the water container, and the water container or base may be provided with a connection terminal to be electrically connected to the electric heating coil and the controller.

**[0046]** If the electric heating coil is mounted at the water container, heat generated from the electric heating coil can be directly transferred to the water stored in the water container.

**[0047]** In another aspect of the present invention, provided herein is a drying machine or washing machine comprising: a receiving unit for providing a receiving space; and a clothes refresher to be mounted in the receiving unit.

**[0048]** The clothes refresher may be configured as stated above.

#### ADVANTAGEOUS EFFECTS

**[0049]** The present invention provides a clothes refresher for enabling short term storage of clothes and for enabling a refresh operation for sterilizing and de-wrinkling the clothes during the short term storage, to achieve an improvement in satisfaction of users.

**[0050]** In particular, the refresher of the present invention can be controlled independently of a conventional drum type drying machine or separate drying apparatus. The refresher is designed to specifically perform the refresh operation of clothes only, having the effect of achieving an improvement in satisfaction of users.

**[0051]** Further, the clothes refresher in accordance with the present invention may cooperate with or be independent of the drying machine or washing machine, which has a separate steam generator. Alternatively, the refresher may be mounted in the drying machine or washing machine.

**[0052]** Furthermore, the refresher in accordance with the present invention has a device to circulate steam, and is adapted to perform the refresh operation by allowing the steam to collide with the clothes so as to shake the clothes. This has the effect of achieving a further improvement in refresh performance.

[0053] Meanwhile, a machine for washing clothes or drying wet clothes in accordance with the present invention has a clothes refresh function, to achieve an improvement in convenience of use.

#### BRIEF DESCRIPTION OF THE DRAWINGS

[0054] The accompanying drawings, which are included to provide a further understanding of the invention, illustrate embodiments of the invention and together with the description serve to explain the principle of the invention.

[0055] In the drawings:

[0056] FIG. 1 is a perspective view illustrating a refresher in accordance with an embodiment of the present invention.

[0057] FIG. 2 is a sectional view taken along the line I-I of FIG. 1.

[0058] FIG. 3 is a rear view of FIG. 1.

[0059] FIG. 4 is a perspective view illustrating the refresher of FIG. 1, which is in use.

[0060] FIG. 5 is a sectional view taken along the line II-II of FIG. 4.

[0061] FIG. 6 is a rear view of FIG. 4.

[0062] FIGS. 7 and 8 illustrate the refresher provided with a lattice partition.

[0063] FIG. 9 illustrates the refresher provided with a blowing device.

[0064] FIG. 10 illustrates the refresher provided with a partition having injection nozzles.

[0065] FIGS. 11 to 21 illustrate a refresher in accordance with a further embodiment of the present invention.

[0066] FIGS. 22 to 28 illustrate a refresher in accordance with another embodiment of the present invention.

[0067] FIGS. 29 to 33 illustrate a refresher in accordance with another embodiment of the present invention.

[0068] FIGS. 34 to 37 illustrate a refresher in accordance with another embodiment of the present invention.

[0069] FIGS. 38 to 44 illustrate a refresher in accordance with another embodiment of the present invention.

[0070] FIGS. 45 to 51 illustrate different various refreshers in accordance with other embodiments of the present invention.

#### BEST MODE FOR CARRYING OUT THE INVENTION

[0071] Reference will now be made in detail to the preferred embodiments of the present invention, examples of which are illustrated in the accompanying drawings.

[0072] Now, a refresher in accordance with a preferred embodiment of the present invention will be explained with reference to FIGS. 1 to 10.

[0073] As shown in FIGS. 1 and 2, the refresher basically comprises a base 100, a steam generator 200, a cover 300, and a body 400.

[0074] Here, the base 100 is configured to have a space for storing a predetermined amount of water required to generate steam.

[0075] Although not shown, it is desirable that the water storage space of the base 100 be formed with a discharge portion for discharging the water, which remains after completing a refresh operation, to the outside. Preferably, the discharge portion is located at a lower surface of the base 100. More preferably, the discharge portion is provided with a valve, which is designed to be electrically opened and closed.

[0076] In particular, it is desirable that the base 100 be further formed with an inlet opening 110 to introduce water into the water storage space.

[0077] Preferably, the inlet opening 110 is formed at a position approximately higher than an appropriate level of water stored in the water storage space. This is for the sake of preventing leakage of the water stored.

[0078] It is desirable that the base 100 be further provided with an inlet passage 120 between the inlet opening 110 and the water storage space. This is for the sake of achieving the accurate introduction of water.

[0079] The inlet opening 110 is preferably provided with an opening/closing door 130, to be selectively opened and closed.

[0080] The steam generator 200, which is one constituent element of the refresher, serves to selectively heat and evaporate the water stored in the base 100.

[0081] The steam generator 200 includes a heat-radiating heater 210, and a controller 220.

[0082] The heat-radiating heater 210 is installed such that one end thereof is located in the water storage space of the base 100 and the other end thereof, which is formed with a terminal, is located at the outside of the water storage space.

[0083] In this case, it is desirable that a region of the heat-radiating heater 210, where the terminal is formed, be provided with a packing 211 for preventing leakage of water.

[0084] In particular, the heat-radiating heater 210 may be preferably a sheath heater. Here, the sheath heater means a heater wherein a coil thereof is surrounded by a highly heat conductive material, such as for example, aluminum or copper, so as not to be exposed to the outside. This is for the sake of preventing the coil from being brought into contact with the stored water.

[0085] The controller 220 is located in an inner space of the base 100 separated from the water storage space, and is adapted to control a heat-radiating operation of the heater 210.

[0086] Preferably, an operation panel 140 is provided at a front surface of the base 100 for manual control of the controller 220. The reason why the operation panel 140 is located at the front surface of the base 100 is to keep the operation panel 140 at a fixed position regardless of folding and unfolding operations of the body 400, and also, to ensure easy manual operation of the operation panel 140 regardless of the user's height.

[0087] In the case of the above described steam generator 200, if the level of water, stored in the water storage space of the base 100, drops below the lowest water level, the heat-radiating heater 210 is exposed to the outside, and this may result in a risk of fire.

[0088] For this reason, although not shown, it is desirable that the steam generator 200 or the base 100 contain at least one of a temperature sensor, humidity sensor, and water level sensor, in order to prevent the level of water from dropping below a pre-determined water level.

[0089] The cover 300, which is one constituent element of the refresher, serves to selectively close an upper surface of the base 100, and preferably, is configured to have a predetermined space therein.

[0090] A holder bar 310 is provided in the space of the cover 300 to hang a clothes hanger thereon. The holder bar 310 is connected at both ends thereof to two shorter side surfaces of the rectangular cover 300 facing each other.

[0091] Of course, it will be appreciated that both the ends of the holder bar 310 may be connected to opposite longer side surfaces of the cover 300 facing each other.

[0092] The cover 300 is preferably formed with an outlet opening 320 to discharge part of air or steam existing in the space of the cover 300.

[0093] The outlet opening 320 may take the form of a simple opening, but may be formed to be adjustable in the degree of opening thereof.

[0094] The body 400, which is one constituent element of the refresher, is connected between the base 100 and the cover 300. Preferably, the body 400 is made of a foldable flexible material.

[0095] In particular, the body 400 is configured to define a predetermined receiving space for receiving clothes, which will be subjected to a refresh operation, when it is unfolded. A surface of the body 400 is provided with a structure for selective opening of the receiving space.

[0096] The structure for opening and closing the receiving space of the body 400 may be preferably a zipper.

[0097] Such a structure for opening and closing the receiving space must allow a user to easily put clothes into the body 400 and take out the clothes from the body 400, and also, prevent steam present in the closed body 400 from leaking to the outside.

[0098] Of course, it will be appreciated that the structure for opening and closing the receiving space may be selected from among a variety of configurations other than the zipper.

[0099] In particular, when the body 400 is made of a flexible material, it is desirable that the refresher further comprise a supporter 500 to support the body 400 when the body 400 is completely unfolded, as shown in FIGS. 3 to 6.

[0100] The supporter 500 is preferably connected at both ends thereof to rear surfaces of both the base 100 and the cover 300 and adapted to be folded and unfolded like a link. Although not shown, it will be appreciated that the supporter 500 may take a telescopic configuration to be extendible and contractible in length thereof.

[0101] Hereinafter, the operational sequence of the refresher having the above described configuration will be explained.

[0102] First, in an initial state of the refresher, the cover 300 closes the upper surface of the base 100 as shown in FIGS. 1 to 3.

[0103] In such a closed state, the body 400 is hidden inside the cover 300 and the base 100 while being in a folded state.

[0104] Then, when it is intended to perform a clothes refresh operation, the cover 300 is opened away from the base 100.

[0105] In accordance with the opening operation of the cover 300, the body 400 is exposed from between the cover 300 and the base 100, and is gradually unfolded.

[0106] Referring to FIGS. 4 to 6, the body 400 is shown in a completely unfolded state.

[0107] After being completely unfolded, the body 400 is able to be continuously kept in the unfolded state by the supporter 500.

[0108] Also, in the completely unfolded state of the body 400, the zipper is operated to open the inner surface of the body 400.

[0109] After clothes to be refreshed are hung on hangers, and in turn, the hangers are hung on the holder bar 310 inside the cover 300, the zipper is again operated to close the inner space of the body 400.

[0110] In this way, the clothes are received in the body 400.

[0111] After that, the controller 220 of the steam generator 200 is controlled to operate the heat-radiating heater 210.

[0112] If the heater 210 operates to radiate heat in accordance with the above described serial procedure, the water stored in the base 100 is heated and evaporated, resulting in generation of steam.

[0113] The steam generated as stated above rises from the inner space of the base 100, to be supplied into the body 400, and consequently, to be supplied to the clothes received in the body 400.

[0114] As a result, the clothes are able to be sterilized and de-wrinkled by the high-temperature steam, to accomplish a refresh operation of the clothes.

[0115] Since the inner space of the body 400 for receiving the clothes has a small volume, in particular, the refresh operation of the clothes can be performed within a short time. This has an advantage in that the clothes can be efficiently refreshed even if the storage time of the clothes is short.

[0116] Meanwhile, if the body 400 is still full of the steam after the refresh operation is performed in the middle of the above described serial procedure, the refreshed clothes may be wet by the steam.

[0117] For this reason, it is desirable that the outlet opening 320 formed at the cover 300 be opened if the refresh operation is performed.

[0118] In the above described refresher, meanwhile, the water storage space of the base 100 for receiving the water required to generate steam is configured to communicate with the inner space of the body 400, and therefore, there is a risk in that a lower end of the clothes may reach the water or the clothes may carelessly drop into the water when they are hung on the holder bar 310.

[0119] Furthermore, in a state wherein the cover 300 closes the base 100 as shown in FIG. 2, the body 400 may be wet by the water stored in the base 100.

[0120] Accordingly, the above described refresher needs a separate structure to solve the above described problems. To comply with this necessity, the refresher of the present invention may further comprise a partition 170 inside the base 100 as shown in FIGS. 7 and 8.

[0121] Preferably, the partition 170 is configured to separate the water storage space of the base 100 from a space above the water storage space while allowing the steam generated by the steam generator 200 to be efficiently supplied into the inner space of the body 400 where the clothes are received.

[0122] For this, the partition 170 may take the form of a lattice grill or mesh.

[0123] When the partition 170 takes the form of the lattice grill or mesh, the steam is able to be distributed throughout the partition 170, and therefore, is able to be uniformly supplied into the overall inner space of the body 400.

[0124] More preferably, the partition 170 may be detachably coupled to an inner wall surface of the base 100, for the sake of cleaning of the inner space of the base 100.

[0125] With the use of the partition 170, even in a state wherein the cover 300 closes the base 100, the body 400 is placed on the partition 170, thereby being kept in a stably folded state without a risk of being wet by the water stored in the base 100.

[0126] Also, in a state wherein the cover 300 opens the base 100, more particularly, in a state wherein the body 400 is unfolded for the use of the refresher as shown in FIG. 8, the

partition **170** prevents the lower end of the clothes from reaching the water stored in the base **100**.

[0127] Referring to FIG. **9**, a blowing device **630** may be mounted at the cover **300**, to facilitate efficient circulation of the steam in the inner space of the body **400**.

[0128] The blowing device **630** is able to discharge air inside the body **400** to the outside, and to achieve efficient circulation of steam and air.

[0129] The reason why the blowing device **630** is provided at the cover **300** is to efficiently supply the steam generated to the uppermost space of the refresher in consideration of the fact that the steam is generated in the lowermost space of the refresher.

[0130] Referring to FIG. **10**, a partition **821** having a plurality of injection nozzles **822** for the injection of steam may be provided.

[0131] The injection nozzles **822** are configured to protrude upward from the partition **821** by a predetermined height, and each has a hollow tubular form.

[0132] Preferably, the injection nozzle **822**, having the hollow tubular form, gradually decreases in an inner diameter toward an upper end thereof, more particularly, toward a steam discharge side, in order to achieve an increase in a steam injection pressure. This facilitates the refresh operation of clothes using the steam.

[0133] As stated above, although the refresher in accordance with the present invention has the basic effects of sterilizing and de-wrinkling clothes, it is also able to remove bad smells of the clothes when perfume is added into the water storage space of the base. Accordingly, it will be appreciated that the refresher can achieve a variety of effects in accordance with functional additives supplied thereto.

#### MODE FOR THE INVENTION

[0134] Now, a refresher for clothes in accordance with a further embodiment of the present invention will be explained with reference to FIGS. **11** to **21**. In the present embodiment, a blowing device is included in the refresher.

[0135] As shown in FIGS. **11** to **13**, a blowing device **600**, may be placed in the base. In this case, it is desirable that the blowing device **600** be located out of the water storage space. The blowing device **600** includes an axial flow fan **601** to axially suck and discharge air, and a motor **602** to rotate the axial flow fan **601**. Preferably, the motor **602** is mounted to eliminate a risk of short circuit due to steam. Also, it is desirable that the blowing device **600** is mounted to discharge air toward the water storage space. The blowing device **600** serves to bring about circulation of steam, and also, to apply a shock to clothes or slightly shake the clothes via collision between the steam and the clothes, thereby functioning as an assistant for a clothes refresh operation.

[0136] Referring to FIGS. **14** and **15**, the lattice partition **170** is preferably provided above the water storage space and the blowing device to allow the passage of steam.

[0137] Referring to FIGS. **16** and **17**, alternatively, a blowing device may be mounted to discharge air upward in an oblique direction.

[0138] In this case, the blowing device **610** includes an axial flow fan **612** to axially suck and discharge air, and a motor **612** to rotate the axial flow fan. The axial flow fan is mounted such that a rotary axis thereof has a predetermined inclination angle.

[0139] The refresher of the present embodiment, as shown in FIG. **17**, acts to allow air to come into direct contact with clothes, so as to accomplish more efficient contact between the steam and the clothes.

[0140] Referring to FIGS. **18** and **19**, alternatively, a blowing device **620** may include a centrifugal fan **621** designed to suck air in an axial direction and to discharge the sucked air in a radial direction.

[0141] In addition to the centrifugal fan **621** to axially suck the air and to radially discharge the sucked air, the blowing device **620** includes a motor **622** to rotate the centrifugal fan **621**, and a case **623** to guide a flow path of the air discharged from the centrifugal fan **621**. The case **623** is formed with a suction hole to correspond to the axial direction of the centrifugal fan **621**, and a discharge hole to correspond to the radial direction of the centrifugal fan. Here, the discharge hole may be oriented to face upward or to be tilted upward.

[0142] With the above described configuration, if the blowing device starts to operate during the implementation of the refresh operation, as shown in FIG. **19**, the steam generated in the steam generator is first sucked axially into the blowing device, and then, is discharged in the radial direction of the blowing device. In this case, the centrifugal fan can successfully achieve higher flow rate of air than the axial flow fan. Therefore, the centrifugal fan is suitable for use in a large capacity refresher.

[0143] Referring to FIGS. **20** and **21**, alternatively, the blowing device **630** may be provided inside the cover **300**. In this case, the blowing device **630** includes a centrifugal fan **631** to suck air in an axial direction and to discharge the sucked air in a radial direction.

[0144] In addition to the centrifugal fan **631** to axially suck the air and radially discharge the sucked air, the blowing device **630** includes a motor **632** to rotate the centrifugal fan **631**, and a case **633** to guide a flow path of the air discharged from the centrifugal fan **631**. The case **633** is formed with a suction hole to correspond to the axial direction of the centrifugal fan **631**, and discharge holes to correspond to the radial direction of the centrifugal fan **631**. Here, preferably, the suction hole is oriented to face downward, and the discharge holes are oriented to face opposite sides of the cover.

[0145] With this configuration, if the blowing device starts to operate during the implementation of the refresh operation, as shown in FIG. **21**, the blowing device sucks air upward in the inner space of the refresher, and discharges the air toward opposite sidewalls of the cover **300**. In this case, in accordance with the flow of air, the steam generated in the steam generator **200** first passes through the clothes. In succession, the steam is sucked into the blowing device **630** and then, is again discharged into the inner space of the refresher. When the circulation of steam is brought about by the circulation of air, it has the effect of preventing the steam from being concentrated on a specific portion of the clothes. Also, when the air is sucked above the clothes, the steam is able to come into contact with the clothes as soon as being evaporated, and therefore, this results in a reduction in heat loss of the steam.

[0146] Now, a refresher in accordance with another embodiment of the present invention will be explained with reference to FIGS. **22** to **28**. In the present embodiment, a steam injection device is included in the refresher.

[0147] An upper steam injection device **700** for injecting steam into an upper space of the body **400** is provided between the base **100** and the cover **300**. The upper steam injection device **700** is configured to inject the steam gener-

ated by the steam generator 200 into the upper space of the body 400 adjacent to the cover 300.

[0148] Here, as shown in FIGS. 22 and 25, the upper steam injection device 700 includes a steam injection pipe 701, and a steam supply pipe 702.

[0149] The steam injection pipe 701 is provided in the cover 300, and has a steam injector 611 including a plurality of holes formed at the bottom of the cover 300 adjacent to the upper space of the body 400.

[0150] The steam supply pipe 702 extends between the base 100 and the steam injection pipe 701 to communicate with the water storage space of the base 100. The steam supply pipe 702 is configured to be extendible and contractible in length.

[0151] Specifically, the steam supply pipe 702 has a telescopic structure such that the length thereof is extendible and contractible in accordance with the unfolding and folding operations of the body 400.

[0152] Preferably, the steam supply pipe 702 is detachably connected to the steam injection pipe 701.

[0153] When the steam supply pipe 702 is detachably connected to the steam injection pipe 701, more preferably, a packing is provided at a joint between the steam supply pipe 702 and the steam injection pipe 701 to seal a steam passage.

[0154] In the present embodiment, although the steam supply pipe 702 is illustrated and explained to be located in the body 400, it will be appreciated that the steam supply pipe 702 may be located at the outside of the body 400.

[0155] One end of the steam supply pipe 702 communicates with the water storage space of the base 100, and the other end of the steam supply pipe 702 communicates with the steam injection pipe 701. Accordingly, as the body 400 is folded and unfolded, the length of the steam supply pipe 702 is contractible and extendible in a telescopic manner.

[0156] Meanwhile, although not shown, the steam supply pipe 702 may have a plurality of longitudinal pleats, which are adapted to be folded and unfolded in a bellows manner, to be extendible and contractible in length.

[0157] The steam, generated by the heat radiating operation of the heater 210, rises along the steam supply pipe 702, and is injected into the upper space of the body 400 through the steam injection holes 611 of the steam injection pipe 701 that communicates with the steam supply pipe 702.

[0158] FIG. 27 illustrates another upper steam injection device.

[0159] Here, a steam injection pipe 711 is integrally formed in the cover 300 to have a pre-determined space therein. The steam injection pipe 711 has a steam injector 713 formed at a bottom surface of the cover 300.

[0160] The steam injector 713 includes an elongated slot extending in a longitudinal direction of the cover 300, more particularly, in a leftward and rightward direction thereof.

[0161] Although not shown, it will be appreciated that the steam injector may take the form of a plurality of holes, or may take the form of a plurality of nozzles.

[0162] In the same manner as the above described steam supply pipe 702, preferably, a steam supply pipe 712 is extendible and contractible in length, and is detachably connected to the steam injection pipe 711.

[0163] FIG. 28 illustrates yet another upper steam injection device.

[0164] In this case, steam is supplied into the inner space of the body 400 via the holder bar 310 that is provided in the cover 300.

[0165] Specifically, the steam injection device includes the holder bar 310 having a plurality of steam injectors 311, and a steam supply pipe 722.

[0166] The steam injectors 311 of the holder bar 310 take the form of a plurality of nozzles arranged along a longitudinal direction of the holder bar 310.

[0167] Although not shown, it will be appreciated that the steam injectors of the holder bar 310 may take the form of an elongated slot extending in the longitudinal direction of the holder bar 310.

[0168] In the same manner as the above described steam supply pipe, preferably, the steam supply pipe 722 is extendible and contractible in length, and is detachably connected to the holder bar 310 to communicate with the inner space of the holder bar 310.

[0169] With the above described configuration, the steam generated by the steam generator 200 is able to be supplied into the upper space of the body 400 through the steam supply pipe 722 and the steam injectors 311 of the holder bar 310, to achieve the refresh operation of clothes.

[0170] Now, a refresher in accordance with another embodiment of the present invention will be explained with reference to FIGS. 29 to 33. In the present embodiment, a lower steam injection device is included in the refresher.

[0171] The lower steam injection device serves to inject the steam generated in the steam generator into a lower space of the body.

[0172] As shown in FIGS. 29 and 31, the lower steam injection device includes a steam injection pipe 810 configured to communicate with the water storage space of the base 100 and having a plurality of steam injection holes 811 to inject steam into the lower space of the body 400.

[0173] The steam generated in the steam generator is supplied into the lower space of the body 400 through the steam injection holes 811 of the steam injection pipe 810.

[0174] FIG. 32 illustrates another lower steam injection device.

[0175] The lower steam injection device includes a steam injector 830, which is formed at the base 100 to communicate with the water storage space of the base 100, and is adapted to enable direct injection of steam into the lower space of the body 400.

[0176] Here, the steam injector 830 takes the form of an elongated slot extending in a longitudinal direction of the base 100.

[0177] Although not shown, it will be appreciated that the steam injector may take the form of a plurality of holes, or may take the form of a plurality of nozzles.

[0178] FIG. 33 illustrates yet another lower steam injection device.

[0179] The lower steam injection device includes a steam injection arm 840 configured to communicate with the water storage space of the base 100. Specifically, the steam injection arm 840 protrudes into the lower space of the body 400 adjacent to the base 100, and has a plurality of steam injectors 841 arranged in a longitudinal direction thereof.

[0180] Preferably, the steam injectors 841 may take the form of nozzles.

[0181] With this configuration, the steam generated by the steam generator 200 is able to be supplied into the lower space of the body 400 through the steam injectors 841 of the steam injection arm 840, to achieve the refresh operation of clothes.

[0182] Now, a refresher in accordance with another embodiment of the present invention will be explained with



reference to FIGS. 34 to 37. In the present embodiment, a structure for receiving steam from an external source is included in the refresher.

[0183] As shown, a steam supply unit 900 is provided on at least one of the base 100 and the cover 300 to receive steam from an external source.

[0184] The steam supply unit 900 includes a pipe connection opening 910 to enable detachable connection of a steam flow pipe, and an opening/closing door 920 to selectively open and close the pipe connection opening 910.

[0185] Preferably, the pipe connection opening 910 is configured to allow the connection of a conventional hose.

[0186] When the refresher is intended to be independently used, the opening/closing door 920 closes the pipe connection opening 910, to prevent leakage of steam.

[0187] Although the above described steam supply unit 900 is illustrated and explained to be formed at a peripheral surface of the base 100, it will be appreciated that the steam supply unit 900 may be formed at a peripheral surface or upper surface of the cover 300.

[0188] In particular, it is desirable that the steam supply unit 900 further include a reader 930 serving as a sensor for sensing the connection or separation of the steam flow pipe.

[0189] If it is determined from read results of the reader 930 that the steam flow pipe is connected, it is desirable that the steam generator 200 be controlled so as not to operate.

[0190] The reader 930 may be selected from among a variety of elements including a limit switch and proximity sensor.

[0191] Of course, it will be appreciated that the steam generator 200 of the refresher may be controlled to operate even when the steam is supplied from an external source through the steam supply unit 900, if necessary.

[0192] Meanwhile, when the refresher in accordance with the embodiment of the present invention is used to cooperate with a washing apparatus 10 (for example, washing machine or clothes drying machine) as shown in FIG. 37, the refresher will be operated in the following serial procedure.

[0193] In this case, assuming that the washing apparatus 10 includes a steam generator 20 that is configured to generate steam independently of the refresher, and that the steam generator 20 is connected to a steam flow pipe 30. Preferably, the steam flow pipe 20 is configured to be selectively pulled out of the washing apparatus 10.

[0194] When using the washing apparatus 10, if it is desired to perform the refresh operation of a variety of clothes received in the refresher by use of the steam generator 20 provided in the washing apparatus 10, the opening/closing door 920, which closes the pipe connection opening 910 of the refresher, is operated to open the pipe connection opening 910.

[0195] Then, the steam flow pipe 30 is connected to the opened pipe connection opening 910.

[0196] If the steam flow pipe 30 is connected, the reader 930 provided at the pipe connection opening 910 recognizes the connection of the steam flow pipe 30, and provides the recognized information to the controller 220 of the refresher, so as to prevent the operation of the steam generator 200 provided in the refresher.

[0197] It will be noted that the opening operation of the cover 300 of the refresher and the serial operation for putting clothes into the body 400 are performed in the same manner as the independent operation of the refresher.

[0198] Then, if the steam generator 20 of the washing apparatus 10 is operated, steam is generated from the steam gen-

erator 20, and is transferred into the inner space of the base 100 of the refresher through the steam flow pipe 30.

[0199] In succession, the transferred steam rises toward the inner space of the body 400 of the refresher, to be supplied to clothes received in the body 400.

[0200] As will be easily understood from the above description, when the refresher of the present invention is used to cooperate with the washing apparatus 10, the steam generator 200 may be omitted. However, in order to allow the refresher to be used independently of and to be combined with the washing apparatus 10, it is most desirable that the refresher includes the steam generator 200.

[0201] One end of the steam flow pipe 30, which is connected at the other end thereof to the steam generator 20 of the washing apparatus 10, may be connected to communicate with the cover 300 rather than the base 100.

[0202] FIGS. 38 to 44 illustrate a machine for washing clothes or drying wet clothes, which includes the refresher.

[0203] As shown in FIGS. 38 to 40, the washing apparatus 10 in accordance with a preferred embodiment of the present invention includes a box-shaped case 30 provided at the bottom thereof to form the outer appearance of the washing apparatus 10, and a box-shaped drawer type receiving unit 40 provided in the case 30 to be pulled out of and pushed into the case 30. The drawer type receiving unit 40 has an open upper surface and internally defines a receiving space.

[0204] The washing apparatus 10 in accordance with the embodiment of the present invention receives the refresher for refreshing clothes inside the drawer type receiving unit 40.

[0205] As stated above, the refresher basically includes the base 100, steam generator 200, cover 300, and body 400. Here, it will be appreciated that the refresher may be configured to receive steam from the washing apparatus. In this case, the steam generator 200 may be omitted.

[0206] When it is desired to operate the refresher for performing the refresh operation of clothes, the drawer type receiving unit 40 is pulled and opened forward of the washing apparatus 10, and then, the refresher installed in the drawer type receiving unit 40 is operated.

[0207] FIGS. 41 to 44 illustrate a variety of installation examples of the refresher usable with the washing apparatus 10 of the present invention.

[0208] Specifically, the refresher usable with the washing apparatus 10 of the present invention may be configured to be independently used, or may be installed in the drawer type receiving unit 40, which is designed to be pulled out of or pushed into the case 30 provided at the bottom of the washing apparatus 10. Of course, it will be appreciated that more efficient use of the refresher can be devised by changing the pulling and pushing direction as well as installation position of the drawer type receiving unit 40.

[0209] Referring to FIGS. 41 and 42, the drawer type receiving unit 40 is configured to be laterally pulled out of and pushed into the case 30 of the washing apparatus 10 from a right-side surface of the case 30, and the refresher is received in the drawer type receiving unit 40.

[0210] Alternatively, as shown in FIG. 43, a pair of refreshers may be received in the bottom of the washing apparatus 10, to be coupled to opposite lateral surface of the washing apparatus 10 when in use.

[0211] It will be appreciated that the overall size of the refresher is adjustable such that three refreshers are received

in the bottom of the washing apparatus 10 to be coupled to front and lateral surfaces of the washing apparatus 10 when in use.

[0212] Alternatively, as shown in FIG. 44, the refresher may be coupled to the top of the washing apparatus 10.

[0213] Although not shown, it is desirable that the refresher be connected to the washing apparatus 10 by use of a hook or other fastening elements, to be selectively detachable therefrom.

[0214] FIGS. 45 to 47 illustrate a refresher in accordance with another embodiment of the present invention.

[0215] The refresher in accordance with the present embodiment includes the base 100 having a water container 1170, steam generator 1170, 1211, 1212, and 1213, cover 300, body 400, and blowing device 640.

[0216] The base 100 is configured to form a body of the refresher in accordance with the embodiment of the present invention. The base 100 has a space for storing a pre-determined amount of water required to generate steam.

[0217] Preferably, the base 100 is provided with a mounting opening 1110 such that the water container 1170 can be put into the base 100.

[0218] More preferably, the mounting opening 1110 is formed at a front surface of the base.

[0219] Also, it is desirable that the mounting opening 1110 is provided with an opening/closing door 1130, to be selectively opened and closed.

[0220] The water container 1170, which is one constituent element of the refresher, is selectively provided in the base 100, and is configured to have a predetermined storage space for storing the water required to generate steam.

[0221] The water container 1170 has a cylindrical vessel form having an open upper surface for the input of water and the discharge of steam.

[0222] The steam generator, which is one constituent element of the refresher, serves to selectively heat and evaporate the water stored in the water container 1170.

[0223] The steam generator basically includes a heat conductive plate 1171, electric heating coil 1212, and controller 1213.

[0224] The heat conductive plate 1171 is provided at an inner wall surface of the water container 1170, more particularly, at a bottom side of the water container 1170 to be mounted in the base 100. Preferably, as shown, the overall bottom surface of the water container 1170 may be provided with the heat conductive plate 1171. Also, a bottom surface of the base 100 is preferably provided with a supporting member 1211 to couple the water container 1170 to the base 100. The electric heating coil 1212 is placed in the supporting member 1211.

[0225] The heat conductive plate 1171 is preferably made of a material having a high heat conductivity. When high-temperature heat is supplied from the electric heating coil 1212 thereto, the heat conductive plate 1171 serves to rapidly conduct the heat throughout the water container 1170.

[0226] Although it is desirable that the heat conductive plate 1171 is provided throughout the inner wall surface of the water container 1170, it has been found that sufficient heat conduction effect can be accomplished even if the heat conductive plate 1171 is provided only at the bottom side of the water container 1170 to be mounted in the base 100 in consideration of an increase in manufacturing costs.

[0227] The electric heating coil 1212 is provided at an inner location of the base 100 where a lower surface of the water

container 1170 is mounted, to provide the heat conductive plate 1171 with high-temperature heat.

[0228] In this case, it is desirable that the electric heating coil 1212 comes into contact, on at least one location thereof, with the heat conductive plate 1171, to achieve efficient heat conduction.

[0229] The controller 1213 is provided in the inner space of the base 100, to control the heat radiating operation of the electric heating coil 1212.

[0230] Although not shown, preferably, at least one of a temperature sensor, humidity sensor, and water level sensor is provided at the steam generator 1170, 1211, 1212, and 1213 or in the base 100, in order to prevent the water stored in the water container from dropping below a predetermined water level.

[0231] The blowing device 640 is placed in the base 100 at the outside of the water container 1170.

[0232] Preferably, the partition 170 is provided above the water container 1170 and the blowing device 640 to allow the passage of steam.

[0233] FIG. 47 illustrates an alternative refresher which is provided with a blowing device 650 at an upper side of the water container 1170. The blowing device 650 includes an axial flow fan 651 to suck and discharge air in an axial direction, and a motor 652 to rotate the axial flow fan.

[0234] FIG. 48 illustrates another partition 1160 configured to separate the water storage space from the remaining inner space of the base 100.

[0235] Meanwhile, when the high-temperature heat generated by the electric heating coil 1212 is transferred to the heat conductive plate 1171 provided in the water container 1170, the steam generator of the above described refresher may fail to achieve efficient heat conduction if the heat conductive plate 1171 (or the bottom surface of the water container) does not come into sufficient contact with the electric heating coil 1212.

[0236] Accordingly, to solve the above problem, hereinafter, a configuration for allowing both the heat conductive plate and the electric heating coil of the steam generator to come into direct contact with each other will be explained.

[0237] FIG. 49 is a sectional view for explaining an alternative configuration of the above described steam generator. As will be appreciated from FIG. 49, the alternative steam generator basically includes a heat conductive plate 1221, an electric heating coil 1222, a power connection terminal 1224, and a controller 1223.

[0238] The heat conductive plate 1221 is provided at the inner wall surface of the water container 1170, more particularly, at the bottom side of the water container 1170 to be mounted on the base 100.

[0239] The electric heating coil 1222 is provided beneath the heat conductive plate 1221.

[0240] Preferably, the electric heating coil 1222 is provided in a space between the lower surface of the water container 1170 and the heat conductive plate 1221. More preferably, the electric heating coil 1222 is configured to come into close contact with the lower surface of the heat conductive plate 1221.

[0241] The bottom surface of the water container 1170 is preferably made of a heat resistance material having a low heat conductivity. This is to prevent damage to peripheral circuit elements when the bottom surface of the water container 1170 is overheated.

[0242] A protrusion 1172 is formed at the water container 1170 to protrude upward by a predetermined height at a position corresponding to the center of the heat conductive plate 1221. A terminal of the electric heating coil 1222 is exposed along an inner circumference of the protrusion 1172.

[0243] The power connection terminal 1224 is received in the base 100, more particularly, in the protrusion 1172 of the water container 1170, to come into contact with the terminal of the electric heating coil 1222.

[0244] The power connection terminal 1224 serves to provide the electric heating coil 1222 with electric power.

[0245] The controller 1223 is provided in the inner space of the base 100, and is adapted to selectively supply electric power to the power connection terminal 1224.

[0246] With the above described configuration, if the water container 1170, in which water is stored, is mounted at a region where the power connection terminal 1224 is located, the electric heating coil 1222 and the power connection terminal 1224 are brought into contact with each other, to enable the supply of electric power to the electric heating coil 1222. Then, if the controller 1223 is operated to start the refresh operation, the electric heating coil 1222 performs a heat radiating operation by use of the electric power supplied thereto.

[0247] If high-temperature heat is generated by the heat radiating operation of the electric heating coil 1222, the high-temperature heat is transferred to the heat conductive plate 1221 that comes into close contact with an upper surface of the electric heating coil 1222, thereby allowing the water stored in the water container 1170 to be heated and evaporated. With the evaporation of water, steam is able to be generated.

[0248] In succession, the steam generated as stated above rises along a steam supply pipe 1620, and is supplied into the upper space of the body 400 through a steam injection pipe 1610 that communicates with the steam supply pipe 1620.

[0249] FIGS. 50 and 51 illustrate yet another embodiment of the present invention. In the present embodiment, the refresher includes a steam injection device. The steam injection device is provided in the base 100, and is configured to inject the steam generated by the steam generator into the lower space of the body 400 adjacent to the base 100.

[0250] The steam injection device, as shown, is configured to communicate with a storage space of a water container 1700, and includes a steam injection pipe 1621 having a plurality of steam injection holes 1622 to inject the steam into the lower space of the body 400.

[0251] It will be apparent to those skilled in the art that various modifications and variations can be made in the present invention without departing from the spirit or scope of the invention. Thus, it is intended that the present invention cover the modifications and variations of this invention provided they come within the scope of the appended claims and their equivalents.

#### INDUSTRIAL APPLICABILITY

[0252] The present invention provides an apparatus for clothes, more particularly, a new clothes refresher having the effects of sterilizing and de-wrinkling clothes.

[0253] The refresher in accordance with the present invention enables short term storage of clothes, and can perform a refresh operation for removing wrinkles of clothes and also sterilizing the clothes during the short term storage. As a result, an improvement in satisfaction of users can be accomplished.

[0254] In particular, the refresher of the present invention can be controlled independently of a conventional drum type drying machine or separate drying apparatus. The refresher is designed to specifically perform the refresh operation of clothes only, having the effect of achieving an improvement in satisfaction of users.

[0255] Further, the clothes refresher in accordance with the present invention may cooperate with or be independent of the drying machine or washing machine, which has a separate steam generator. Alternatively, the refresher may be mounted in the drying machine or washing machine.

[0256] Furthermore, the refresher in accordance with the present invention has a device to circulate steam, and is adapted to perform the refresh operation by allowing the steam to collide with the clothes so as to shake the clothes. This has the effect of achieving a further improvement in refresh performance.

[0257] Meanwhile, a machine for washing clothes or drying wet clothes in accordance with the present invention has a clothes refresh function, to achieve an improvement in convenience of use.

#### 1. A clothes refresher comprising:

a body configured to receive clothes therein; and  
a steam supply device to supply steam into the body in order to supply the steam to the clothes.

#### 2. A clothes refresher comprising:

a base having a water storage space;  
a body configured to receive clothes therein; and  
a steam generator to heat water stored in the base to generate steam, in order to supply the steam to the clothes received in the body.

3. The refresher as set forth in claim 2, wherein the body is foldable, and a cover is provided at an upper side of the body to cover the base.

4. The refresher as set forth in claim 3, wherein the base has an inlet opening to be supplied with water from an external source into the water storage space, and a passage extending from the inlet opening to the water storage space.

5. The refresher as set forth in claim 4, wherein the inlet opening is provided with an door for opening and closing thereof.

6. The refresher as set forth in claim 3, wherein the steam generator includes:

a heater mounted in the water storage space of the base; and  
a controller to control the heater.

7. The refresher as set forth in claim 3, wherein the cover is provided with a holder bar for hanging clothes thereon.

8. The refresher as set forth in claim 3, wherein the cover has an outlet opening to discharge air or steam.

9. The refresher as set forth in claim 3, wherein the body has a zipper for putting the clothes into the body and taking out the clothes from the body.

10. The refresher as set forth in claim 3, wherein the base is provided with a lattice partition placed above the water storage space.

11. The refresher as set forth in claim 3, further comprising:  
a steam supply pipe provided between the water storage space and the cover,

wherein the steam supply pipe extendible and contractible in length and adapted to transfer the steam generated in the water storage space to the clothes received in the body.

12. The refresher as set forth in claim 3, wherein the base is provided with a partition, which is placed above the water storage space and provided with a plurality of injection nozzles.

13. The refresher as set forth in claim 3, further comprising: a blowing device for circulating air.

14. The refresher as set forth in claim 13, wherein the blowing device is mounted in the base.

15. The refresher as set forth in claim 13, wherein the blowing device includes an axial flow fan to suck and discharge air in an axial direction.

16. The refresher as set forth in claim 13, wherein the blowing device includes a centrifugal fan to suck air in an axial direction and to discharge the air in a radial direction.

17. The refresher as set forth in claim 14, wherein the blowing device is mounted such that an air discharge direction thereof faces the water storage space of the base.

18. The refresher as set forth in claim 13, wherein the cover is formed with an outlet opening to discharge air or steam, and the blowing device is mounted at the outlet opening.

19. The refresher as set forth in claim 3, further comprising: a steam injection device to inject the steam generated by the steam generator into an inner space of the body.

20. The refresher as set forth in claim 3, further comprising: an upper steam injection device to inject the steam generated by the steam generator into an upper space of the body.

21. The refresher as set forth in claim 20, wherein the upper steam injection device includes:

a steam injection pipe provided to the cover and having a steam injector; and

a steam supply pipe having one end communicating with the steam injection pipe and the other end communicating with the water storage space of the base, the steam supply pipe being extendible and contractible in length.

22. The refresher as set forth in claim 21, wherein the steam supply pipe is detachably connected to at least the steam injection pipe.

23. The refresher as set forth in claim 21, wherein the steam injection pipe takes the form of a holder bar for hanging the clothes thereon.

24. The refresher as set forth in claim 3, further comprising: a lower steam injection device to inject the steam generated by the steam generator into a lower space of the body.

25. The refresher as set forth in claim 24, further comprising:

a partition to separate the water storage space of the base from an inner space of the body,

wherein the lower steam injection device is mounted on the partition and has a steam injection pipe having a steam injector.

26. The refresher as set forth in claim 24, further comprising:

a partition to separate the water storage space of the base from an inner space of the body,

wherein the lower steam injection device has an elongated slot formed in the partition.

27. The refresher as set forth in claim 24, further comprising:

a partition to separate the water storage space of the base from an inner space of the body,

wherein the lower steam injection device includes a steam injection arm having a plurality of steam injection holes and placed longitudinally above the partition by a long length.

28. The refresher as set forth in claim 3, wherein the refresher is provided with a connection opening for the connection of a steam flow pipe, to receive steam supplied from an external source through the steam flow pipe.

29. The refresher as set forth in claim 28, wherein the connection opening is formed in the base or the cover.

30. The refresher as set forth in claim 28, wherein the connection opening is provided with a sensor for sensing the connection or separation of the steam flow pipe.

31. A machine for washing or drying clothes comprising: a receiving unit having a receiving space; and a clothes refresher mounted in the receiving unit.

32. The machine as set forth in claim 31, wherein the clothes refresher includes:

a base having a water storage space;

a body foldable and configured to receive clothes therein in an unfolded state; and

a steam generator to heat water stored in the base to generate steam, in order to supply the steam to the clothes received in the body.

33. The refresher as set forth in claim 2, wherein the base includes a water container for storing water therein, the water container being detachably mounted in the water storage space.

34. The refresher as set forth in claim 33, wherein the steam generator includes:

an electric heating coil to heat the water container to thereby generate steam; and

a controller to control the electric heating coil.

35. The refresher as set forth in claim 33, wherein the base has a closable mounting opening to put or take out the water container into or from the base.

36. The refresher as set forth in claim 34, wherein the electric heating coil is provided to the water container, and

wherein the water container or the base is provided with a connection terminal for electrically connecting the electric heating coil to the controller.

37. The refresher as set forth in claim 3, wherein the body is made of a flexible material, and is provided with a supporter to support and keep the body in an unfolded state.

38. The refresher as set forth in claim 38, wherein the supporter has a link structure or telescopic structure.

\* \* \* \* \*