

(19) World Intellectual Property Organization
International Bureau



(43) International Publication Date
6 March 2003 (06.03.2003)

PCT

(10) International Publication Number
WO 03/019715 A1

(51) International Patent Classification⁷: **H01P 1/203**, 7/10

(21) International Application Number: PCT/SE02/01461

(22) International Filing Date: 16 August 2002 (16.08.2002)

(25) Filing Language: English

(26) Publication Language: English

(30) Priority Data:
0102785-3 22 August 2001 (22.08.2001) SE

(71) Applicant (for all designated States except US): **TELEFONAKTIEBOLAGET L M ERICSSON (PUBL)** [SE/SE]; S-126 25 Stockholm (SE).

(72) Inventors; and

(75) Inventors/Applicants (for US only): **GEVORGIAN, Spartak** [AM/SE]; Adler Salvius gata 15, S-411 11 Göteborg (SE). **DELENIV, Anatoly** [UA/SE]; Bokgården 26, S-424 39 Göteborg (SE). **VENDIK, Orest** [RU/RU];

Flat 456., Building 42-1, Korableistroitelay Street, St. Petersburg 199155 (RU). **KOLLBERG, Erik** [SE/SE]; Diabasvägen 7, S-437 32 Lindome (SE). **WIKBORG, Erland** [SE/SE]; Lundblads Väg 3, S-182 33 Danderyd (SE).

(74) Agents: **BERGENTALL, Annika** et al.; Cegumark AB, P.O. Box 53047, S-400 14 Göteborg (SE).

(81) Designated States (national): AE, AG, AL, AM, AT, AU, AZ, BA, BB, BG, BR, BY, BZ, CA, CH, CN, CO, CR, CU, CZ, DE, DK, DM, DZ, EC, EE, ES, FI, GB, GD, GE, GH, GM, HR, HU, ID, IL, IN, IS, JP, KE, KG, KP, KR, KZ, LC, LK, LR, LS, LT, LU, LV, MA, MD, MG, MK, MN, MW, MX, MZ, NO, NZ, OM, PH, PL, PT, RO, RU, SD, SE, SG, SI, SK, SL, TJ, TM, TN, TR, TT, TZ, UA, UG, US, UZ, VC, VN, YU, ZA, ZM, ZW.

(84) Designated States (regional): ARIPO patent (GH, GM, KE, LS, MW, MZ, SD, SL, SZ, TZ, UG, ZM, ZW), Eurasian patent (AM, AZ, BY, KG, KZ, MD, RU, TJ, TM), European patent (AT, BE, BG, CH, CY, CZ, DE, DK, EE, ES, FI, FR, GB, GR, IE, IT, LU, MC, NL, PT, SE, SK,

[Continued on next page]

(54) Title: A TUNABLE FERROELECTRIC RESONATOR ARRANGEMENT

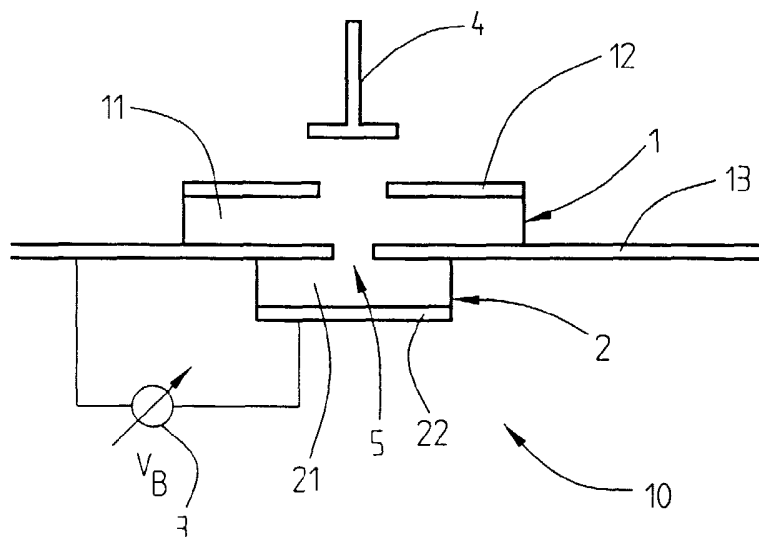

(57) Abstract: The present invention relates to a tunable resonating arrangement comprising a resonator apparatus (10), input/output coupling (4) means for coupling electromagnetic energy into/out of the resonator apparatus, and a tuning device (3) for application of a biasing voltage/electric field to the resonator apparatus. The resonator apparatus comprises a first resonator (1) and a second resonator (2). Said first resonator is non-tunable and said second resonator is tunable and comprises a ferroelectric substrate (21). Said first and second resonators are separated by a ground plane (13) which is common for said first and second resonators, and coupling means (5) are provided for providing coupling between said first and second resonators. For tuning of the resonator apparatus, the biasing voltage/electric field is applied to the second resonator (2).

WO 03/019715 A1



TR), OAPI patent (BF, BJ, CF, CG, CI, CM, GA, GN, GQ, GW, ML, MR, NE, SN, TD, TG).

For two-letter codes and other abbreviations, refer to the "Guidance Notes on Codes and Abbreviations" appearing at the beginning of each regular issue of the PCT Gazette.

Published:

— *with international search report*

Title:

A TUNABLE FERROELECTRIC RESONATOR ARRANGEMENT

5

FIELD OF THE INVENTION

The present invention relates to a tunable resonating arrangement which comprises a resonator apparatus. Electromagnetic energy is coupled into/out of the resonator apparatus over input/output coupling means, and for tuning of the resonator apparatus, a tuning device is used for application of a biasing/tuning voltage (electric field) to the resonator apparatus. The invention also relates to such a resonator apparatus, a tunable filter arrangement, and to a method of tuning a resonating arrangement.

STATE OF THE ART

Electrically tunable resonators are attractive components for agile radar and mobile radio communication systems. Different types of resonators are known. Dielectric and parallel plate resonator and filters for microwave frequencies using dielectric disks of any shape, for example circular, are known e.g. from Vendik et al., Electronics Letters vol. 31, p. 654, 1995, which herewith is incorporated herein by reference.

Parallel plate resonators comprising substrates of non-linear dielectric materials with extremely high dielectric constants, for example ferroelectric materials or anti-ferroelectric materials, have small dimensions, and they can for example be used to provide very compact filters in the frequency bands in which advanced microwave communication systems operate. Such non-linear dielectric materials may e.g. be STO(SrTiO₃) with a dielectric constant of about 2000 at the temperature of liquid

nitrogen and a dielectric constant of about 300 at room temperature.

Dielectric, parallell plate resonators can be excited by simple
5 probes or loops. For the majority of practical implementations
the thickness of a parallell plate resonator is much smaller
than the wavelength of the microwave signal in the resonator in
order for the resonator to support only the lowest order TM
modes and in order to keep the DC-voltages, which are required
10 for the electrical tuning of the resonator comprising a
dielectric substrate with electrodes arranged on both sides of
it, as low as possible. For such resonators electrical tuning is
obtained by means of the application of an external DC-biasing
voltage, which is supplied by means of ohmic contacts to the
15 electrodes acting as plates of the resonator. Tunable resonators
based on thin film substrates as well as resonators based on
dielectric bulk substrates are known. A resonator is considered
to be electrically thin if the thickness is smaller than half
the wavelength of the microwave signal in the resonator such
20 that no standing waves will be present along the axis of the
disk. Electrically tunable resonators based on circular
ferroelectric disks have recently been found attractive and have
drawn much attention for example for applications as tunable
filters in microwave communication systems, as well as in mobile
25 radio communication systems.

Such devices are for example described in "Tunable Microwave
Devices", which is a Swedish patent application with application
number 9502137-4 and "Arrangement and method relating to
30 tunable devices" which is a Swedish patent application with
application number 9502138-2 which herewith are incorporated
herein by reference.

Substrates comprising ferroelectric materials in resonators and filters are of interest for different reasons. Among other things ferroelectric materials are able to handle high peak power, they have a low switching time, and the dielectric constant of the substrate varies with an applied biasing voltage, which makes the impedance of the device vary with an applied biasing electric field. For example US-A-5 908 811, "High Tc Superconducting Ferroelectric Tunable Filters", shows an example of such a filter which should get low losses by means of using a single crystal ferroelectric material. A ferroelectric thin film substrate is used. However, this device as well as other resonators and filters based on ferroelectric materials suffer from the drawback of the quality factor (Q-value) of the ferroelectric substrate or element decreasing drastically with the applied voltage, when a biasing voltage is applied. This has recently been established by A. Tagantsev in "DC-Electric-Field-induced microwave loss in ferroelectrics and intrinsic limitation for the quality factor of a tunable component", Applied Physics Letters, Vol. 76, No. 9, p. 1182-84, to be a consequence of a fundamental loss mechanism (called quasi-Debye Effect) induced in the ferroelectric material by the applied biasing field. However, so far, no satisfactory solution to the problem associated with induced losses in tunable ferroelectric resonators has been found.

25

SUMMARY OF THE INVENTION

What is needed is therefore a tunable resonating arrangement, more particularly for microwaves or millimeter waves, which has small dimensions and which can be used in different kinds of advanced microwave communication systems and mobile radio communication systems. A tunable resonator arrangement is also needed which has a high, or at least satisfactory, performance, and which is easy to fabricate. Particularly a tunable resonating arrangement is needed through which it is possible to

30

compensate for the losses in a ferroelectric substrate upon application of an electric field/voltage for tuning purposes. Particularly an arrangement is needed which has a high power handling capability. Even more particularly an arrangement is
5 needed through which tuning by the means of the application of a DC-biasing can be provided substantially without deteriorating the quality factor (Q-value) of the resonator.

An arrangement is also needed which is compact in size for use
10 in different types of components, which can be tuned efficiently without requiring too high amounts of power, and which is reliable in operation. Moreover an arrangement is needed which is robust and which has a satisfactory tuning selectivity and tuning sensitivity, and through which the insertion losses are
15 low or can be compensated for.

A tunable filter arrangement is also needed which comprises one or more resonator apparatuses and which meets one or more of the objects referred to above. Still further a method of tuning a
20 resonator arrangement is needed through which the above mentioned objects can be achieved, and particularly a method of compensating for the losses induced in a ferroelectric resonator substrate through electrical or electronical tuning.

25 Therefore a tunable resonating arrangement is provided which comprises a resonator apparatus, input/output coupling means for coupling electromagnetic energy into/out of the resonator apparatus, and a tuning device for application of a biasing voltage/electric field to the resonator apparatus. The resonator
30 apparatus comprises a first resonator and a second resonator. The first resonator is a non-tunable high quality resonator (i.e. having a high Q-factor) , and the second resonator is a tunable resonator comprising a ferroelectric substrate. The first and second resonators are separated by a ground plane

which, however, is common for, i.e. shared by, said first and second resonators, and coupling means are provided for providing coupling between said first and second resonators. For tuning of the resonator arrangement, a tuning voltage/electric field is applied to the second resonator. Advantageously the first resonator is a disk resonator, or a parallell plate resonator, and the second resonator is another disk resonator or a parallell plate resonator. Advantageously the first resonator comprises a dielectric substrate, the electric permittivity of which does not, or substantially not, vary with applied voltage, which dielectric substrate is disposed between a first and a second electrode plate, of which electrodes the second electrode forms the ground plane.

The second resonator preferably comprises a tunable ferroelectric substrate and a first and a second electrode plate. The second electrode plate forms the common ground plane and thus is common with, or the same as, the second electrode of the first resonator, which means that the two resonators share an electrode plate which forms the ground plane for both of said resonators.

The dielectric substrate of the first resonator may for example comprised LaAlO_3 , MgO , NdGaO_3 , Al_2O_3 , sapphire or a material with similar properties. Particularly the quality factor (Q-value) of the first resonator may exceed approximately 10^5 - $5 \cdot 10^5$.

The substrate of the second resonator may for example comprise SrTiO_3 , KTaO_3 , or BaSTO_3 or any other material with similar properties.

30

The first and second electrodes of each resonator, which here means the first electrodes and the common ground plane, in one implementation consist of normal conducting metal, such as for example Au, Ag, Cu. In another implementation the first and

second electrodes, i.e. the first electrodes and the common ground plane, consist of a superconducting material. Even more particularly the first and second electrodes, i.e. the first electrodes and the common ground plane, consist of a high temperature superconducting material (HTS), for example YBCO (Y-Ba-Cu-O). Other alternatives are TBCCO and BSCCO. In a particular implementation superconductors or superconducting films (HTS) are used, which may be covered by thin non-superconducting high conductivity films of for example Au, Ag, Cu or similar. Such devices are also discussed in "Tunable Microwave Devices" which was incorporated herein by reference. Particularly the first and second resonators are TM020 mode resonators. However, also other modes can be selected, as discussed example in the Swedish patent application "Microwave Devices and Method Relating Thereto" with application number 9901190-0, which herewith is incorporated herein by reference, and which illustrates how different modes can be selected, and which gives example on which mode(s) that can be selected, for exemplifying reasons.

20

Through the application of a tuning (biasing) voltage to said second resonator, electromagnetic energy will be distributed to the first resonator and, particularly, as the biasing voltage increases, more and more electromagnetic energy will be distributed or transferred to the first resonator since the resonators are coupled the way they are. This means that the distribution of electromagnetic energy between the first and second resonators depends on the biasing (tuning) voltage or the electric field and of course the coupling means. The resonating frequency in the second resonator increases with the application of an increasing biasing voltage. As the biasing voltage increases, also the loss tangent of the second, ferroelectric, resonator will increase, at the same time as less of the electromagnetic energy will be located in it. Thereby will

automatically be compensated for the increased loss tangent of the second resonator in that the influence thereof on the coupled resonator apparatus comprising the first and the second resonators will be reduced.

5

Particularly the first and second resonators comprise disk resonators based on a dielectric/ferroelectric bulk material. They may however also comprise thin film substrates. However, by using tunable disk resonators resonating arrangements, particularly filters, which have a much higher power handling capability than those made of tunable thin film, can be realized.

Particularly the resonating arrangement comprises at least two resonator apparatuses, and the common ground plane is common for (shared by) the at least two resonator apparatuses to form a tunable filter.

According to the invention, for coupling a first and a second resonator to each other, the coupling means may comprise, for each resonator apparatus, a slot or an aperture in the common ground plane. The resonators may be of substantially any appropriate shape, they may e.g. be circular, square-shaped, rectangular or ellipsoidal etc. The shape of the first resonator may also differ from that of the second resonator. The resonator apparatus may also be a dual mode resonator apparatus. Then each resonator comprises mode coupling means such as for example a protrusion, a cut-out or any other means to provide for dual mode operation. Examples thereon are provided in the patent applications incorporated herein by reference. According to the invention it can be said that tunability and losses is exchanged or distributed between the two resonators of a resonator apparatus, thereby reducing the effect of the induced increasing losses caused by the electrical tuning.

According to the invention thus a tunable resonator apparatus is provided which comprises a first resonator and a second resonator, wherein in said first resonator is non tunable, said
5 second resonator is tunable and ferroelectric, i.e. comprises a ferroelectric substrate, whereby said first and second resonators are separated by a ground plane which is common for said first and second resonators. Coupling means are provided for providing coupling between said first and second
10 resonators, and for tuning of the resonator apparatus, a tuning voltage is applied to the second resonator. Particularly the first and the second resonator comprises disk resonators or parallell plate resonators, and the common ground plane is formed by a second electrode plate of the first resonator which
15 is common with a second electrode plate of the second resonator. The coupling means particularly comprises a slot or an aperture or similar in the common ground plane, through which electromagnetic energy can be transferred from one of the resonators to the other.

20

The invention also discloses a method of tuning a resonator arrangement which comprises the steps of; providing a first, non-tunable resonator; providing a second tunable resonator, such that the first and second resonators are separated by a
25 common ground plane; providing a coupling means in said common ground plane such that the first and second resonators become coupled for transfer of electromagnetic energy between the first and second resonators; changing the resonant frequency thereof by application of a biasing/tuning voltage/electric field to
30 said second resonator, both increasing the resonant frequency, the loss tangent of the second resonator and the redistribution of electromagnetic energy to the first resonator; optimizing the application of a biasing voltage/electric field such that the influence of the increased loss tangent in the second resonator

on the coupled resonator apparatus will be compensated for by a higher transfer of electromagnetic energy to the first resonator. Particularly the resonator apparatus discloses one or more of the features mentioned above.

5

BRIEF DESCRIPTION OF THE DRAWINGS

The invention will in the following be further described in a non-limiting manner and with reference to the accompanying drawings, in which:

10

Figs. 1A-1F for illustrative purposes show the current lines (field distributions) for a number of different TM modes of a circular, parallel plate resonator,

15 Fig. 2 particularly illustrates a state of the art resonator having a field distribution as in Fig. 1A,

Fig. 3 shows the measured microwave performance of the resonator in Fig. 2,

20

Fig. 4 illustrates a cross-sectional view of a first embodiment of a resonator apparatus according the present invention,

25 Fig. 5 illustrates the equivalent circuit of the two coupled resonators of the resonator apparatus in Fig. 4,

30 Fig. 6A is a diagram illustrating a dependence of the capacitance of the resonator as a function of the biasing voltage,

Fig. 6B diagram illustrating the loss factor as function of biasing voltage,

Figs. 7A-7C show simulated results of the dependence of the input impedances, of the equivalent circuit, on biasing voltage,

5

Fig. 8A schematically illustrates one example of a first resonator that can be used in the resonator apparatus of Fig. 4,

10 Fig. 8B schematically illustrates an example of a resonator that can be used as a second resonator in the resonator apparatus of Fig. 4,

Fig. 9A shows an alternative implementation of a first resonator of a resonator apparatus according to the invention,

15

Fig. 9B illustrates an example of a second resonator that can be used with the first resonator of Fig. 9A in a resonator apparatus according to the invention,

20

Fig. 10 very schematically illustrates an example of a dual mode resonator that can be used in a resonator apparatus according to the invention,

25

Fig. 11 schematically illustrates a two-pole filter based on a resonating arrangement according to the present invention,

30 Fig. 12 illustrates the equivalent circuit for the two-pole filter of Fig. 11,

Figs. 13A,B illustrate simulated results of the insertion losses and the return losses as functions of the frequency

for different values of the biasing voltage for a tunable two-pole filter as in Fig. 11.

DETAILED DESCRIPTION OF THE INVENTION

5 Figs. 1A-1F disclose, for illustrative purposes, the lower order TM_{nmp} field distributions for a circular parallel plate resonator, i.e. the TM_{010} , TM_{110} , TM_{210} , TM_{020} , TM_{310} , TM_{410} -modes. Solid lines indicate the current, dashed lines indicate the magnetic field and dots and crosses indicate the electric field.
 10 It is supposed that $p=0$, i.e. that the thickness of the substrate is smaller than half a wavelength in the resonator, and that the resonator only supports TM_{nm0} -modes. The field/current distributions are fixed in space by coupling arrangements (such as coupling loops, coupling probes, or a
 15 further resonator).

Parallel plate resonators, for example in the form of circular dielectric disks and circular patches on dielectric substrates, have found several different microwave applications. The
 20 resonators are seen as electrically thin if the thickness (d) is smaller than half the wavelength of the microwave (λ_g) in the resonator, $d < \lambda_g/2$, so that no standing waves will be present along the axis of the disk. Electrically tunable resonators based on circular ferroelectric disks have been largely
 25 investigated for applications in tunable filters. A simplified electrodynamic analysis of a parallel plate resonator proposes a simple formula for the resonant frequency:

$$30 \quad f_{nm0} = \frac{c_0 k_{nm}}{2\pi r \sqrt{\epsilon}}$$

where $c_0=3.10^8$ m/s is the velocity of light in vacuum, ϵ is the relative dielectric constant of the disk/substrate, r is the radius of the conducting plate, and k_{nm} are the roots of Bessel functions with mode indexes n and m . For an electrically thin parallel-plate resonator the third index is 0. The above formula
5 may be corrected taking fringing fields into account.

Particularly attractive for filter applications are for example the axially symmetric modes with plate currents only in the
10 radial direction. These modes are characterized by higher quality factors (Q) since they do not have any surface currents along the edges of the conductor plates.

In a particularly advantageous implementation of the present
15 invention, the mode selected for the resonators is the TM_{020} mode. The invention is however not limited to any particular mode but substantially any mode could be selected. Mode selection is among others discussed in "Microwave Device and Method Relating Thereto" with Application No. 9901190-0 as
20 discussed earlier in the application.

Fig. 2 schematically illustrates an electronically tunable resonator 10_0 based on a non-linear dielectric substrate 3_0 with an extremely high dielectric constant, e.g. STO ($SrTiO_3$)
25 which has a dielectric constant of more than 2000 at the temperature of liquid nitrogen (N) and a dielectric constant of about 300 at room temperature. On both sides of the substrate high temperature superconductors 1_{01} , 1_{02} , e.g. of YBCO, are provided which in turn, in this embodiment, are covered by thin
30 non-superconducting, high conductivity films 2_{01} , 2_{02} of e.g. Au. As an example the resonant frequencies of a circular parallel plate disk resonator having a diameter of 10 mm and a thickness of 0.5 mm will be in the range of 0.2-2.0 GHz depending on the temperature and on the applied DC biasing. Such resonators can

be excited by simple probes or loops as in/out coupling means. In most practical cases the thickness of a parallel plate resonator is much smaller than the wavelength of the microwave signal in order for the resonator to support only the lowest order TM-modes, and in order to keep the DC-voltages, which are required for the electrical tuning of the resonator with a non-linear dielectric substrate as low as possible. This is discussed in Gevorgian et al., "Low order modes of YBCO/STO/YBCO circular disk resonators", IEEE Trans. Microwave Theory and Techniques vol. 44, No. 10, Oct. 1996 which herewith is incorporated herein by reference. The field distribution of such a resonator was shown in Fig. 1A above, for the TM_{010} mode, and in Fig. 1D for the TM_{020} mode.

Fig. 3 schematically illustrates a diagram indicating the measured microwave performance of two resonators. In the figure the unloaded quality factor, Q , as a function of the biasing voltage, is illustrated for a resonator in which normally conducting, i.e. non-superconducting, electrode plates are used, corresponding to Q_{II} , and for a resonator in which HTS electrodes of YBCO are used, corresponding to lines Q_I . Correspondingly the resonant frequencies are illustrated as a function of the applied biasing voltage, corresponding to F_I , F_{II} for Cu electrodes and for YBCO electrodes respectively. It can be seen that at high biasing voltages, it does not make much difference whether YBCO electrodes are used or if normally conducting (non-superconducting) electrode are used.

Advantageously the resonant frequency of a such resonator should be between 0.5-3GHz, which is the frequency region of cellular communication systems. Thus, the problem of the Q - values of the ferroelectric elements, or non-linear dielectric materials, as discussed above, decreasing drastically with the applied electric field, according to the invention is solved by means of

a resonator apparatus comprising two coupled resonators, e.g. as described in Fig. 4, to provide for a so called loss compensation.

5 Thus, in Fig. 4 a first embodiment of the present invention is illustrated. It shows a resonator arrangement 10 comprising a resonator apparatus with a first resonator 1 and a second resonator 2, which resonators are coupled to each other. The first resonator comprises a circular disk resonator with a first
10 electrode plate 12, and a linear substrate 11 with a high quality factor (Q) which is not tunable. The substrate material may for example comprise sapphire, LaAlO_3 or any of the other materials referred to earlier in the application. The first resonator 1 comprises another electrode plate 13 disposed on the
15 other side of the linear substrate. The electrodes 12, 13 may comprise a "normally" conducting (i.e. non-superconducting, but preferably high conductivity) metal, such as for example Au, Ag, Cu but they may also comprise a superconducting material. In a particularly advantageous implementation the
20 electrode plates 12, 13 comprise a high temperature superconducting material, e.g. YBCO.

The resonator apparatus 10 further comprises a second resonator 2, which is tunable and comprises a substrate material 21 of
25 e.g. a ferroelectric material, e.g. SrTiO_3 , KTaO_3 or any other of the materials as referred to earlier in the application having a growing loss factor, i.e. for which the quality factor decreases with the applied voltage as discussed above with reference to Fig. 3. Also the second resonator 2 is a circular
30 disk resonator with a first electrode plate 22 and a second electrode plate 13, which is the same electrode plate as the second electrode of the first resonator 1.

Thus the common electrode 13 forms a common ground plane for the first and second resonators 1,2. The first and second resonators 1,2 are coupled to each other through coupling means 5, here comprising a slot or an aperture in the common ground plane 13 allowing for distributing of electromagnetic energy between the two resonators upon application of a biasing voltage. For application of said biasing voltage, biasing means 3 are provided comprising a variable voltage source which is connected to the ground plane 13 and to the first electrode 21 of the second resonator 2, such that for tuning of the resonator apparatus, the biasing voltage is applied to the second resonator 2. When the biasing voltage V_B is applied and increased, the resonant frequency of the second resonator 2 will increase. Electromagnetic energy will then be relocated to the first resonator 1, which means that the increased loss tangent of the second resonator, which, as discussed above, increases as the biasing voltage is increased, will have a low influence on the resonator apparatus as such. Thus, as the biasing voltage increases, more and more electromagnetic energy will be transferred or redistributed to the first resonator 1. In this manner the increased loss in the tunable second resonator 2 will be compensated for.

Preferably the coupling slot is circular; which shape it should have depends on the mode(s) that is/are selected. Generally the current lines (cf. Figs 1A-1F) should not be interrupted. Normally it functions with a circular slot for all modes. It may also be ellipsoidal. For a rectangular resonator it may be rectangular.

30

The first and second resonators may also have other shapes, the same or different. The ground plane may also have the same size (and shape) as the first resonator or any other shape as long as it is not smaller than the first resonator.

In the figure input coupling means 4 in the form of an antenna are shown for input of microwave signals to the microwave device for exciting the relevant mode or modes. In principle any input/output coupling means can be used and the antenna is merely indicated for indication of an example on input coupling means. Different types of input/output coupling means are discussed in the Swedish patent application "Arrangement and Method Relating to Microwave Devices" filed on April 18, 1997 with the application No. 9701450-0 and the content of which herewith is incorporated herein by reference. In this document it is among other illustrated how the coupling means can be used for application of a biasing voltage. It also illustrates examples on coupling means that can be used while still requiring separate biasing means, as well as a number of state of the art devices. The present invention is not limited to any particular way of coupling microwave energy into/out of the device, the main thing being that the biasing voltage is applied to the second resonator, which is tunable, and which is coupled to another resonator which is not tunable, which resonators are coupled to one another such that redistribution of electromagnetic energy is enabled.

One example of a second resonator that can be used in a resonator apparatus according to the present invention was disclosed in Fig. 3. The second resonator 2 may also be a thin parallel plate microwave resonator, thin here meaning that it is thin in comparison with the wavelength in the resonator, λ_g , more specifically $d < \lambda_g/2$, wherein d is the thickness of the resonator 2, and λ_g is the wavelength in the resonator. (Generally the apparatus could be a thin film device, although bulk substrate devices are preferred, as discussed earlier.)

In Fig. 5 the equivalent circuit of the two coupled resonators 1,2 of Fig. 4 is illustrated. Z_{in} represents the input impedance of the arrangement R_1 , C_1 represent the resistor and the capacitor of the first, non-tunable resonator 1. R_2 , C_2 represent the tunable components of the second resonator 2, and C_0 is the coupling capacitor coupling the first and second resonators to each other.

With reference to Figs. 6A,6B,7A,7B,7C follows an illustration and explanation of a simulation of the input impedance of the equivalent circuit of Fig. 5. It is here supposed that d_1 is the loss factor of the linear dielectric substrate of the first resonator and $d_2(U)$ is the loss factor of the non-linear ferroelectric substrate of the second resonator as a function of the biasing voltage. The biasing voltage V is given in Volts, L (the inductance) in nH. U_0 and k are phenomenological characteristics of the ferroelectric material. The simulations are done for three different biasing voltages, namely for $V = 0, 100, 200V$ and $U_0 = 200V$. It is further supposed that $C_1 = 2.5$ pF, $C_{20} = 120$ pF, and $C_0 = 200$ pF. $L = 1.59 \times 10^{-9}$, $m = 0.115$, $L_2 = 0,0517 \times 10^{-9}$ H, $d_{20} = 3 \times 10^{-4}$ and $k = 30$, $L_0 = L \times m$ and $L_{00} = L \times (1-m)$.

$$C_2(U) = C_{20}/(1+(U/U_0)^2) \text{ and } d_2(U) = d_{20} (1 + k \cdot (U/U_0)^2).$$

Fig. 6A illustrates the dependence of $C_2(U)$ on the applied voltage U and Fig. 6B illustrates the dependence of $d_2(U)$ on the applied biasing voltage. The input impedance of the first resonator is given by:

$$Z_1(f) = i \omega(f) \cdot L_{00} + \frac{10^{12}}{i \omega(f) \cdot C_1} (1 + i \cdot d_1)$$

and the input impedance of the second resonator is given by:

$$Z2(f,U) = i \cdot \omega(f) \cdot L2 + \frac{10^{12}}{i \omega(f) \cdot C2(U)} (1 + i \cdot d2(U))$$

5

Thus the input impedance of the equivalent circuit will be:

$$Z(f,U) = \left[\frac{1}{i \omega(f) L0} + \frac{1}{Z1(f) + \left[i \omega(f) \cdot C 10^{-12} + Z2(f,U)^{(-1)} \right]^{-1}} \right]^{-1}$$

10

Figs. 7A illustrate the real and imaginary parts of the input impedance at zero applied voltage. Correspondingly Figs. 7B, 7C illustrates the real and imaginary parts of the impedance at a biasing voltage of 100V and 200V respectively. As can be seen from the figures, for zero biasing voltage the resonant frequency will be about 2459.4 MHz, for a biasing voltage of 100V it will be 2509.3 MHz and for an applied biasing voltage of 200V it will be about 2530.9 MHz. The frequency shift ΔF will be 49.9 MHz for 100V and 71.5 MHz for 200 V biasing voltage. In the given range of the applied voltage, the loss factor of the ferroelectric, tunable substrate material will change about 30 times. However, the total quality factor change will be no more than about $\pm 30\%$. If the frequency band of the resonator is about 0.5 MHz, the resonator figure of merit will be $\Delta F/\Delta f \approx 71.5/0.5 \approx 140$. It should however be clear that Figs. 6A, 6B, 7A, 7B, 7C merely are included for illustrative and exemplifying purposes.

Fig. 8A shows one particular example of a first resonator 1A e.g. as in Fig. 4, which comprises a circular disk resonator. It

30

comprises a non-tunable, high quality linear substrate 11A, a first conducting electrode 12A, which for example may be superconducting or even high temperature superconducting, and a second electrode 13A which for example is a larger than the substrate 11A and the first electrode 12A. It may for example also have the same size as the first electrode 12A. This second electrode plate 13A acts as a common ground plane for the first resonator 1A and for the second resonator 2A of Fig. 8B. The common ground plane 13 comprises coupling means 5A for coupling the first resonator 1A and the second resonator 2A to each other.

The second resonator 2A comprises a first electrode 22A disposed on a ferroelectric substrate e.g. of STO which is non-linear and has an (extremely) high dielectric constant. Biasing means comprising a variable voltage source V_0 3 with connection leads is connected to the common ground plane 13A and to the first electrode plate 22A of the second resonator 2A. Preferably the TM_{020} modes are excited via input coupling means (not shown in this figure). The coupling means 5A may comprise a slot which is circular or ellipsoidal, and through which electromagnetic energy from the second resonator 2A can be redistributed to the first resonator 1A upon application of a biasing voltage to the second resonator 2A.

25

Figs. 9A, 9B in a manner similar to that of Figs. 8A, 8B illustrate a first resonator 1B (Fig. 9A) and a second resonator 2B (Fig. 9B) together forming an alternative resonator apparatus in which the first and second resonators 1B, 2B are square-shaped. The first resonator 1B, like in the preceding embodiment, comprises a linear material with a high quality which is non-tunable, e.g. of $LaAlO_3$, and the second resonator 2B comprises a tunable ferroelectric material e.g. of STO. The first resonator 1B comprises a first electrode plate 12B which

30

of course can be similar to the electrode plate of Fig. 8A with the difference that it is square-shaped, but it may also, as illustrated in the figure, comprise a very thin, (thin in order not to affect the surface impedance) superconducting layer 12B₁ covered, on the side opposite to the substrate, by a non-superconducting high conductivity film 12B₂ e.g. of Au, Ag, Cu or similar for protective purposes. Particularly the superconducting film is high temperature superconducting, e.g. of YBCO.

10

In a corresponding manner the second resonator 2B comprises a first electrode plate 22B with a (high temperature) superconducting layer 22B₁ covered by a non-superconducting metal layer 22B₂. The first and second resonator 1B, 2B, like in the preceding embodiment, comprise a common ground plane, for both forming a second electrode 13B which, in this particular implementation, comprises a (high temperature) superconducting layer 13B₁ covered on either side by a very thin non-superconducting metal film 13B₂, 13B₃. Alternatively the ground plane just consists of a superconducting layer. A biasing voltage is applied between the first and second electrodes 22B, 13B of the second resonator 2B and electromagnetic energy can be redistributed via coupling means 5B, which here comprises a rectangular slot, to the first resonator 1B. It should be clear that the coupling means does not have to be a rectangular slot, but it can be any kind of aperture giving the desired properties as far as transfer of electromagnetic energy is concerned for the concerned modes. It may e.g. be circular or ellipsoidal as well. Still further the electrodes may consist of normal metal only.

The inventive concept is also applicable to dual mode operating resonators, oscillators, filters whereby dual mode operation can be provided for in different manners, e.g. as disclosed in the

patent application "Tunable Microwave Devices" which was incorporated herein by reference.

Fig. 10 for illustrative purposes shows a very simplified top view of a dual mode resonator apparatus comprising input $4C_{in}$ and output $4C_{out}$ coupling means and a protruding portion 6 for providing coupling enabling dual mode operation. A dual mode operating resonator apparatus can also be provided for by rectangularly shaped resonators or in any other appropriate manner. The coupling slot for coupling between the first and second resonator is illustrated by the dashed line circle.

In one implementation the inventive concept is extended to a tunable filter 100, cf. Fig. 11. It is supposed that two resonator apparatuses 10D, 10E are provided each comprising a first resonator 1D, 1E respectively and a second resonator 2D, 2E respectively, which share a common ground plane 13F. In this embodiment the first resonators 1D,1E comprise a common substrate 11C. There may alternatively be separate substrates. The distance between the resonator apparatuses gives the coupling strength of the filter. It may e.g. be supposed that the resonator apparatuses comprise circular disk resonators as described in for example Figs. 4-8 or any other alternative kind of resonators, the main thing being that two resonator apparatuses as discussed herein are used to provide a tunable two-pole filter. Coupling between the resonators of each resonator apparatus is provided by coupling means 5D, 5E. By using tunable disk resonators, the power handling capability will be higher than if thin film resonators are used. The in-, and output coupling means are not illustrated in this Fig.

Fig. 12 illustrates the equivalent circuit of a two-pole filter 100 as in Fig. 11 which is connected by a transmission line section. In the figure it is illustrated the first resonator

apparatus 10D with resistance R_{1D} and capacitance C_{1D} corresponding to the first non-tunable resonator 1D and the tunable resonator 2D comprising a resistor R_{2D} and capacitor C_{2D} which resonators are coupled to each other by the coupling means 5D represented by a capacitor C_{04} . The inductances L_{04} , L_{004} ; L_{05} , L_{005} of the resonators are also illustrated in the figure as explained earlier with reference to Fig. 6A, 6B, 7A, 7B. To the first resonator apparatus is connected a second resonator apparatus 10E comprising a first resonator 1E and second resonator 2E with the respective non-tunable and tunable components resistance R_{1E} , C_{1E} and R_{2E} , C_{2E} respectively and connecting capacitor C_{05} corresponding to coupling means 5E. It is supposed that the two-pole filter is connected by a transmission line section. In the exemplifying figure the characteristic impedance of the external line $Z_0 = 50$ Ohm, the characteristic impedance of the coupling line $Z_{01} = 45$ Ohm, and the electrical length of the coupling line at the central frequency is 80° .

Figs. 13A, 13B are diagrams showing simulated lines of the tunable two-pole filter of Fig. 10. The insertion losses in dB and the return losses in dB correspond to the transmissions T and the reflectivity. Γ is given for three different values of a biasing voltage V . In Fig. 13A T_1 corresponds to the transmission as a function of the frequency at zero biasing voltage, T_2 corresponds to the transmission as a function of the frequency in GHz for a biasing voltage of 100V and T_3 is the transmission for a biasing voltage of 200V. Correspondingly the reflectivities Γ_1 , Γ_2 , Γ_3 are indicated in Fig. 13B for biasing voltages 0V, 100V, 200V. As can be seen the insertion losses and the return losses are maintained even at a higher biasing voltage. The average bandwidth is 15 MHz, and the range of tunability is approximately 70 MHz with an insertion loss ≈ 0.5 dB. The drastically increasing loss factor of the ferroelectric

material of the second resonator is largely compensated for through the application of the inventive concept.

It should be clear that the inventive concept can be varied in a number of ways without departing from the scope of the appended claims. Particularly the resonators may be of other different shapes, they may comprise different substrate materials as discussed in the foregoing, they may comprise non-superconducting or particularly (high temperature) superconducting electrodes etc. They may also be single mode operating or dual mode operating and any appropriate type of coupling means may be provided for coupling in of electromagnetic energy to excite the desired modes, i.e. the modes which are selected, particularly the TM_{020} modes. However, also other modes can be selected in any appropriate manner.

It is also possible to use the concept for building different types of filters, band pass filters as well as band reject filters etc.

CLAIMS

1. A tunable resonating arrangement comprising a resonator
5 apparatus (10;100), input/output coupling (4;4C_{in},4C_{out}) means
for coupling electromagnetic energy into/out of the resonator
apparatus, and a tuning device (3) for application of a biasing
voltage/electric field to the resonator apparatus,
c h a r a c t e r i z e d i n
10 that the resonator apparatus comprises a first resonator
(1;1A;1B;1C;1D;1E) and a second resonator (2;2A;2B;2D;2E), that
said first resonator is non-tunable, that said second resonator
is tunable and comprises a ferroelectric substrate (21), that
said first and second resonators are separated by a ground plane
15 (13;13A;13B;13F) which is common for said first and second
resonators, that coupling means (5;5A;5B;5C;5D;5E) are provided
for providing coupling between said first and second resonators,
and in that for tuning of the resonator apparatus, the biasing
voltage/electric field is applied to the second resonator
20 (2;2A;2B;2D;2E).
2. A tunable resonating arrangement according to claim 1,
c h a r a c t e r i z e d i n
that the first resonator, (1;1A;1B;1C;1D;1E) is a disk
25 resonator, or a parallell plate resonator.
3. A tunable resonating arrangement according to claim 1 or 2,
c h a r a c t e r i z e d i n
that the second resonator (2;2A;2B;2D;2E) is a disk resonator,
30 or a parallell plate resonator.
4. A tunable resonating arrangement according to claim 2 or 3,
c h a r a c t e r i z e d i n

that the first resonator comprises a dielectric substrate (11;11A;11B;11C), the electric permittivity of which substantially does not vary with applied biasing voltage, which is disposed between a first and a second electrode, and in that
5 the second electrode of the first resonator forms the ground plane.

5. A tunable resonating arrangement according to claim 4,
c h a r a c t e r i z e d i n
10 that the dielectric substrate (11;11A;11B;11C) of the first resonator comprises LaAlO₃, MgO, NdGaO₃, Al₂O₃, sapphire or a material with similar properties.

6. A tunable resonating arrangement according to claim 4 or 5,
15 c h a r a c t e r i z e d i n
that the first resonator (1;1A;1B;1C;1D;1E) has a high quality factor (Q), e.g. $10^5 - 5 \cdot 10^5$

7. A tunable resonating arrangement according to any one of
20 claims 4-6,
c h a r a c t e r i z e d i n
that the second resonator (2;2A;2B;2D;2E) comprises a tunable ferroelectric substrate and a first (22;22A;22B) and a second electrode (13;13A;13B;13F), and in that the second electrode of
25 the second resonator forms the common ground plane, and thus is the same as the second electrode of the first resonator.

8. A tunable resonating arrangement according to claim 7,
c h a r a c t e r i z e d i n
30 that the ferroelectric substrate (21;21A;21B) of the second resonator comprises SrTiO₃, KTaO₃, BaSTO₃ or a material with similar properties.

9. A tunable resonating arrangement according to any one of claims 4-8,

characterized in

that the first and second electrodes, i.e. the first electrodes
5 and the common ground plane, consist of normal, non-
superconducting metal, e.g. Au, Ag, Cu.

10. A tunable resonating arrangement according to any one of claims 4-8,

10 characterized in

that the first and second electrodes, i.e. the first electrodes
and the common ground plane, consist of a superconducting
material.

15 11. A tunable resonating arrangement according to any one of claims 4-8 or 10,

characterized in

that the first and second electrodes, i.e. the first electrodes
and the common ground plane consist of a high temperature
20 superconducting material (HTS), e.g. YBCO.

12. A tunable resonating arrangement according to any one of the preceding claims,

characterized in

25 that upon the application of a tuning (biasing) voltage to said second resonator (2;2A;2B;2D;2E), electromagnetic energy (EM) will be redistributed between the second and first resonators via the coupling means (5;5A;5B;5C;5D;5E).

30 13. A tunable resonating arrangement according to claim 12,

characterized in

that the distribution of electromagnetic energy depends on the biasing voltage.

14. A tunable resonating arrangement according to claim 13,
c h a r a c t e r i z e d i n
that the transfer of electromagnetic energy from the second
resonator to the first resonator increases with an increasing
5 biasing voltage.

15. A tunable resonating arrangement according to claim 10, 13
or 14,
c h a r a c t e r i z e d i n
10 that the resonating frequency and the loss tangent of the second
resonator increase with the application of an increasing biasing
voltage, and in that also the transfer of electromagnetic energy
from the second to the first resonator is increased,
automatically compensating for the increased loss tangent of the
15 second resonator by reducing the influence thereof on the
coupled resonator apparatus.

16. A tunable resonating arrangement according to claim 1,
c h a r a c t e r i z e d i n
20 that the first and second resonators comprise thin film
substrates.

17. A tunable resonating arrangement according to any one of the
preceding claims,
25 c h a r a c t e r i z e d i n
that it comprises at least two resonator apparatuses, and in
that the common ground plane (13;13A;13B;13F) is common for the
at least two resonator apparatuses which form a tunable filter
(100).

30
18. A tunable resonating arrangement according to any one of the
preceding claims,
c h a r a c t e r i z e d i n

that the coupling means comprises, for each resonator apparatus, a slot or an aperture (5;5A;5B;5C;5D;5E) in the common ground plane.

5 19. A tunable resonating arrangement according to any one of the preceding claims,
c h a r a c t e r i z e d i n
that each resonator is circular, square shaped, rectangular or ellipsoidal.

10

20. A tunable resonating arrangement according to claim 19,
c h a r a c t e r i z e d i n
that it comprises a dual mode resonator apparatus, and in that each resonator comprises a protrusion (6), a cut-out or a
15 perturbation to provide for dual mode operation.

21. A tunable resonator apparatus,
c h a r a c t e r i z e d i n
that it comprises a first resonator and a second resonator, that
20 said first resonator is non-tunable, that said second resonator is a tunable ferroelectric resonator, that said first and second resonators are separated by a ground plane which is common for said first and second resonators, that coupling means are provided for providing coupling between said first and second
25 resonators, and in that for tuning of the resonator apparatus, a biasing voltage is applied to the second resonator.

22. A tunable resonator apparatus according to claim 21,
c h a r a c t e r i z e d i n
30 that the first resonator and the second resonator comprise parallel plate resonators, that the common ground plane is formed by a second electrode plate of the first resonator and of a second electrode of the second resonator, and in that the

coupling means comprises a slot or an aperture in the common ground plane.

23. A tunable resonator apparatus according to claim 22,

5 c h a r a c t e r i z e d i n
that the first resonator comprises a substrate, bulk or thin film, of LaAlO_3 , MgO , NdGaO_3 , Al_2O_3 , sapphire, or a material with similar properties, and in that the second resonator comprises a substrate, bulk or thin film, of SrTiO_3 , KTaO_3 , or a material
10 with similar properties, the electrode plates comprising normal metal, or (high temperature) superconductors.

24. A method of tuning a resonator apparatus,

c h a r a c t e r i z e d i n
15 that it comprises the steps of:
- providing a first, non-tunable, resonator,
- providing a second tunable resonator, such that the first and second resonators are separated by and share common ground plane,
20 - providing coupling means in said common ground plane such that the first and second resonators become coupled, allowing transfer of electromagnetic energy between the first and second resonators,
- applying a biasing/tuning voltage to said second resonator
25 increasing the resonating frequency, the loss tangent of the second resonator, and the transfer of electromagnetic energy to the first resonator,
- optimizing the application of the biasing voltage such that
30 the influence of the increased loss tangent in the first resonator, on the coupled resonator apparatus, will be compensated for, by an increased transfer of electromagnetic energy to the first resonator.

25. The method of claim 24,

c h a r a c t e r i z e d i n

that the first resonator and the second resonator comprise disk or parallell plate resonators, that the common ground plane is formed by a second electrode plate of the first resonator and of
5 a second electrode of the second resonator, and in that the coupling means comprises a slot or an aperture in the common ground plane.

26. The method of any one of claims 24-25,

10 c h a r a c t e r i z e d i n

that the first resonator comprises a substrate, bulk or thin film, of LaAlO_3 , MgO , NdGaO_3 , Al_2O_3 , sapphire, or a material with similar properties, and in that the second resonator comprises a substrate, bulk or thin film, of SrTiO_3 , KTaO_3 , or a material
15 with similar properties, the electrode plates comprising normal metal, or (high temperature) superconductors.

27. The method of any one of claims 24-26,

c h a r a c t e r i z e d i n

20 that it comprises the step of:

- coupling two or more resonator apparatuses such that a filter is provided,
- optimizing the coupling between the respective first and second resonator such that the increasing loss factor produced
25 by an increased biasing voltage, in the ferroelectric substrates, can be reduced.

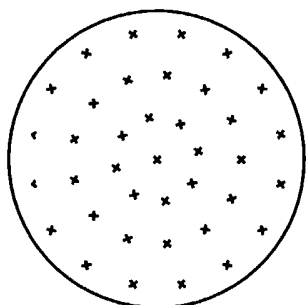

TM_{010}
Fig. 1A

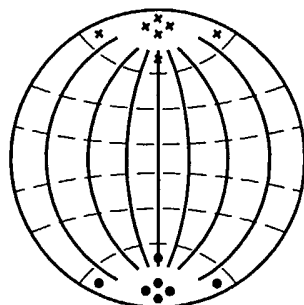

TM_{110}
Fig. 1B

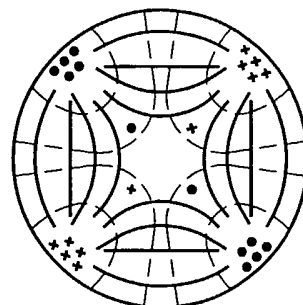

TM_{210}
Fig. 1C

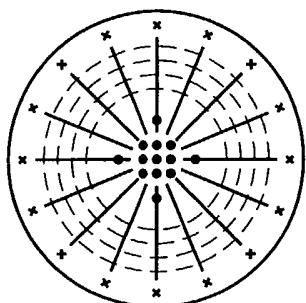

TM_{020}
Fig. 1D

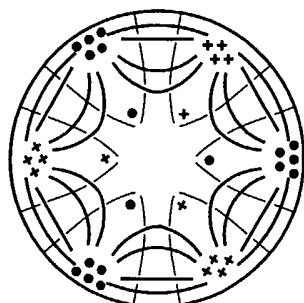

TM_{310}
Fig. 1E

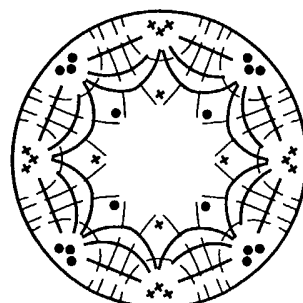

TM_{410}
Fig. 1F

2/10

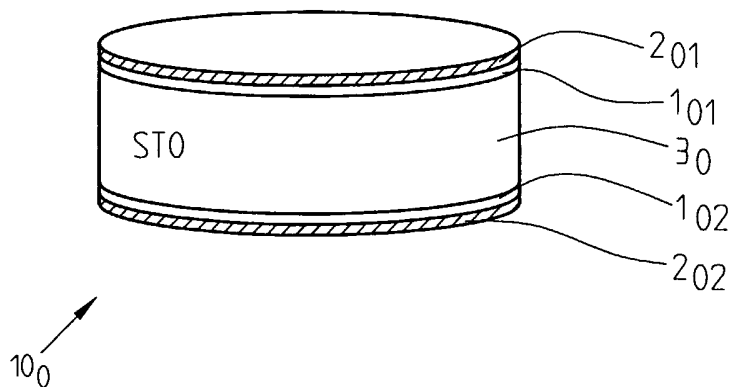

Fig. 2

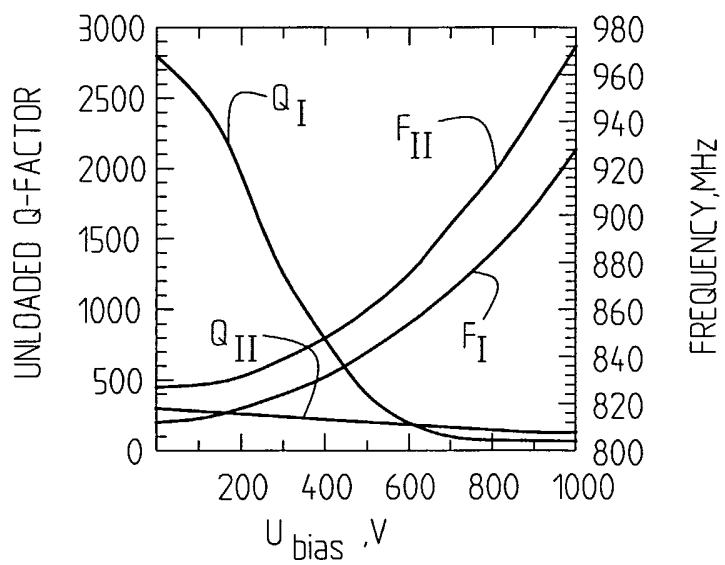

Fig. 3

3/10

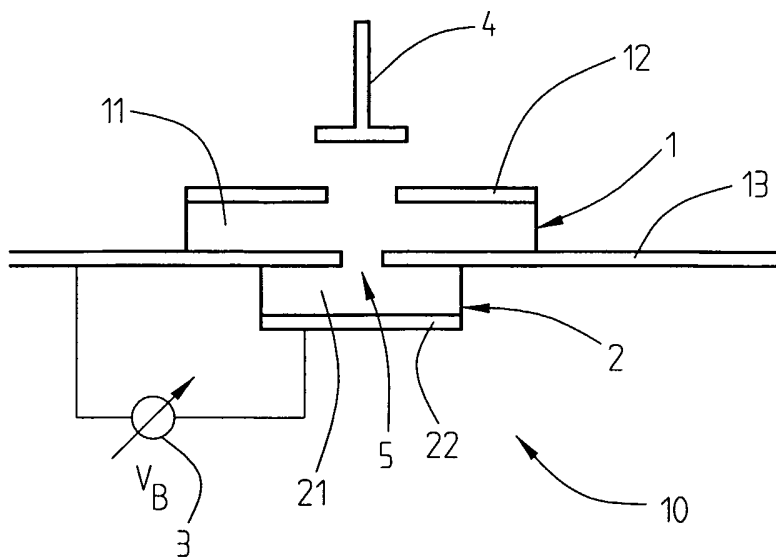

Fig. 4

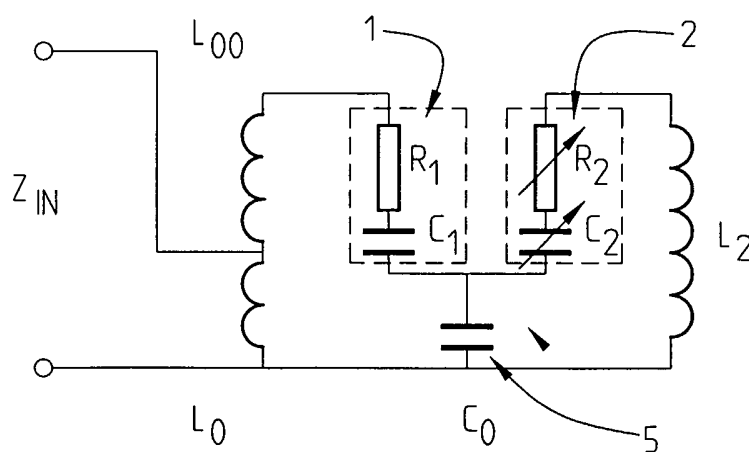

Fig. 5

4/10

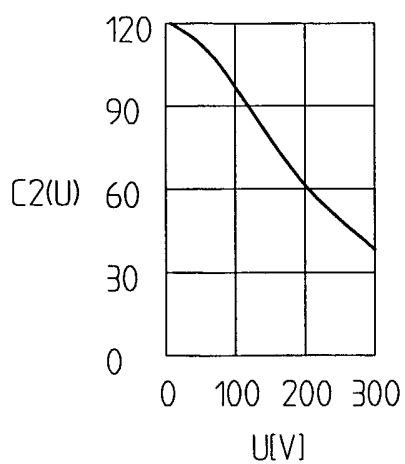

Fig. 6A

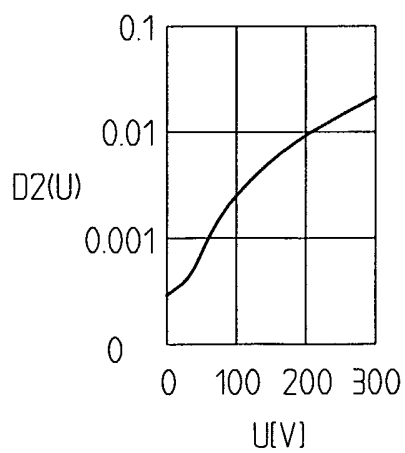

Fig. 6B

5/10

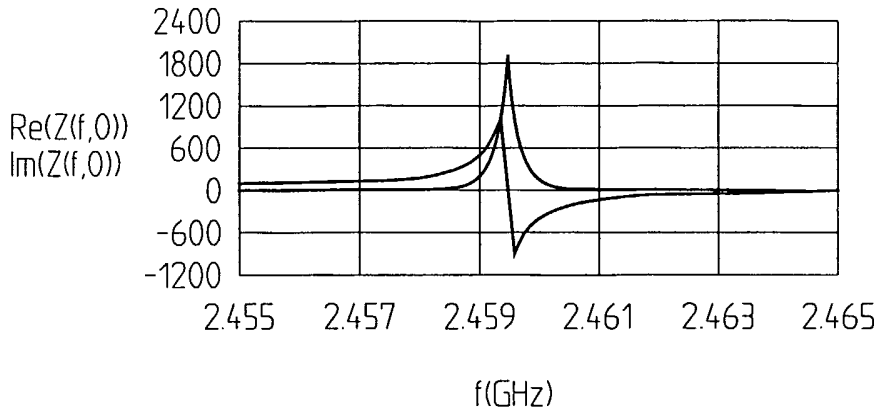

Fig. 7A

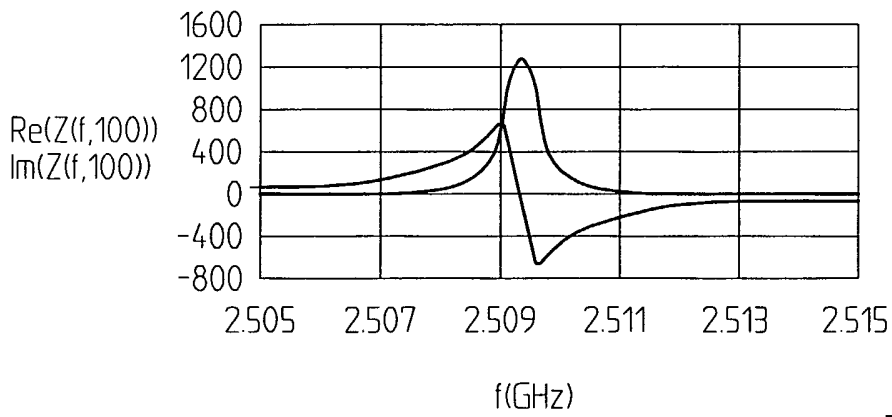

Fig. 7B

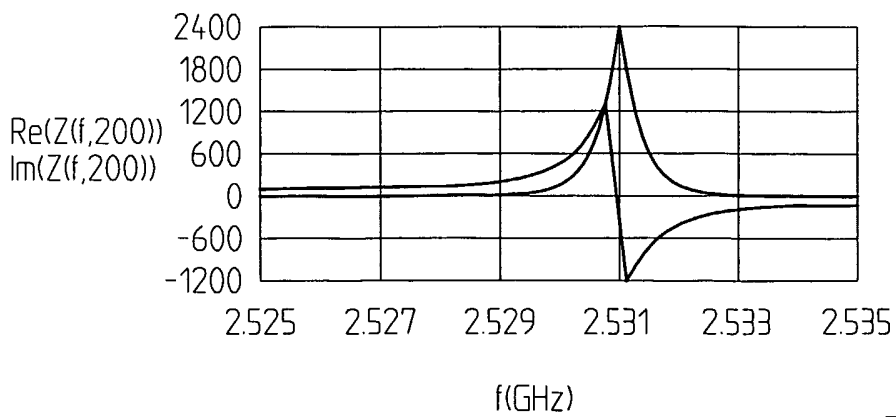

Fig. 7C

6/10

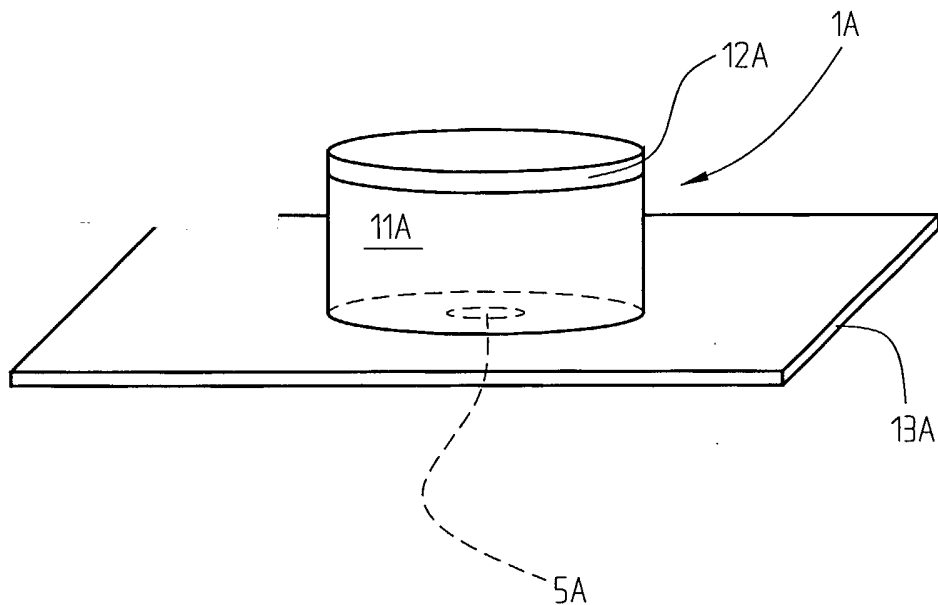

Fig. 8A

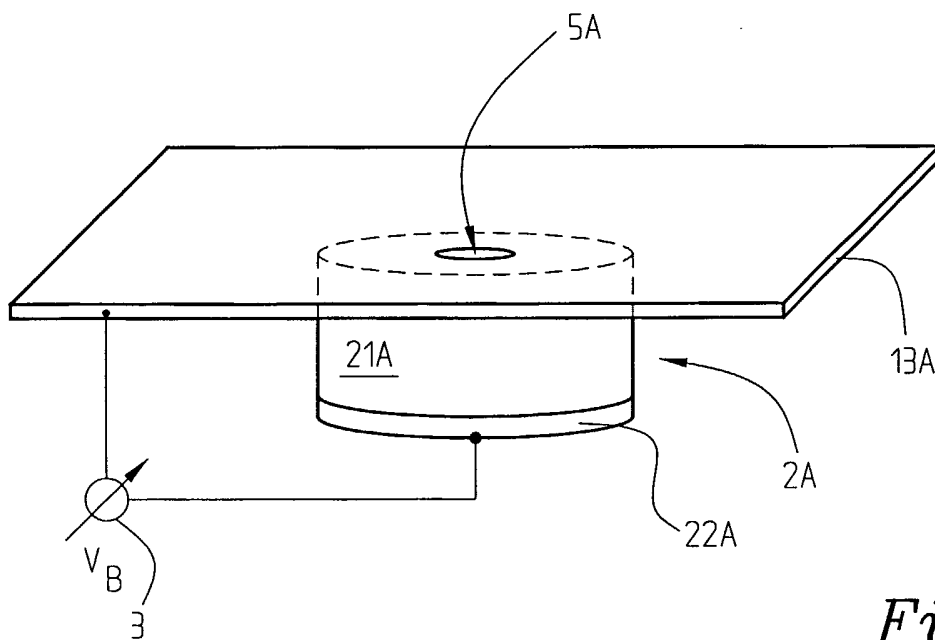

Fig. 8B

7/10

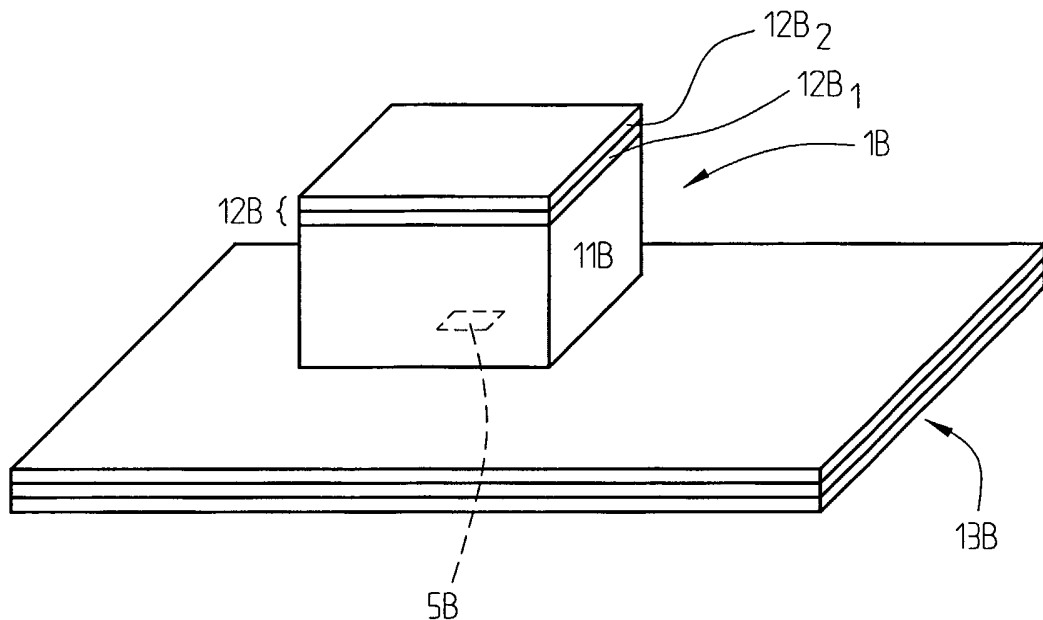

Fig. 9A

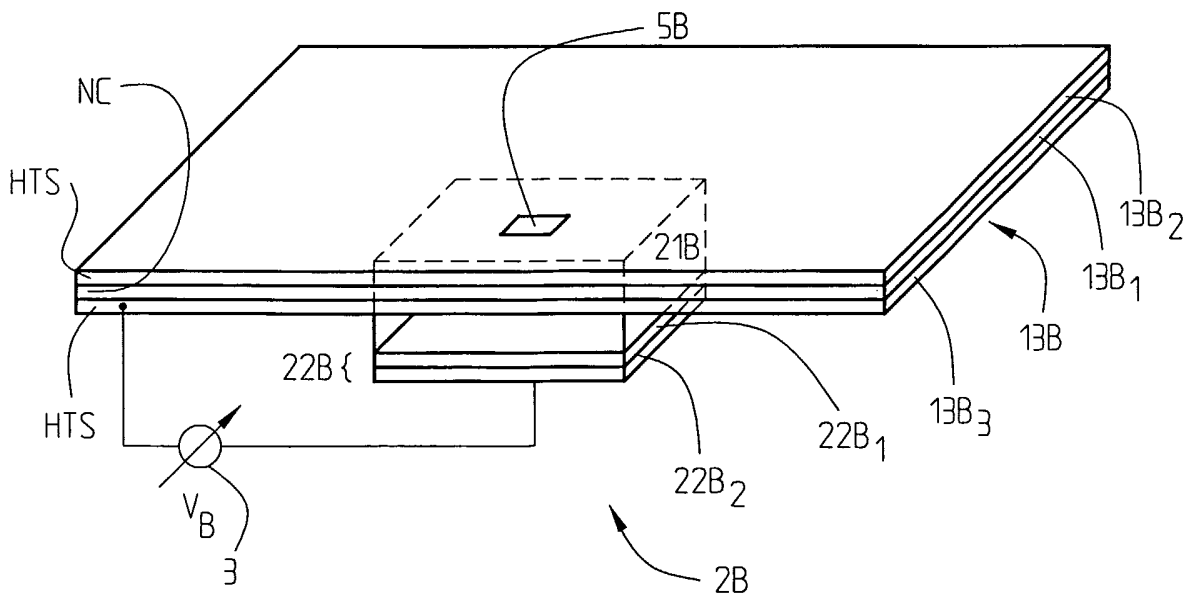

Fig. 9B

8/10

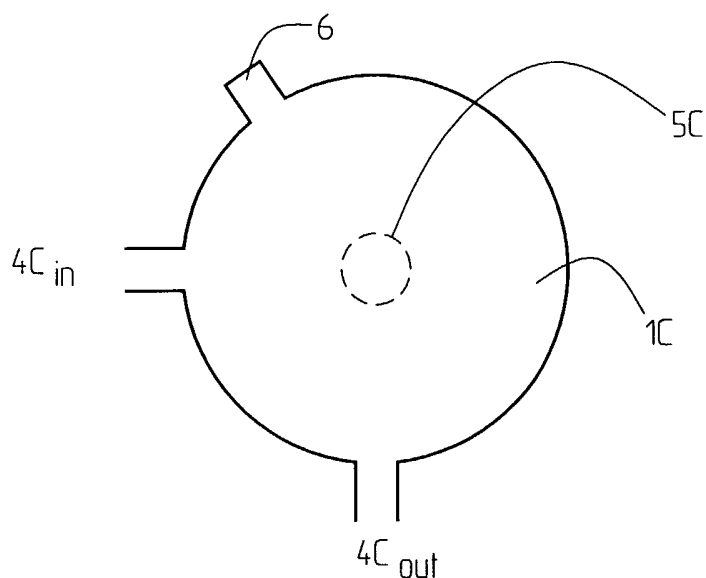

Fig. 10

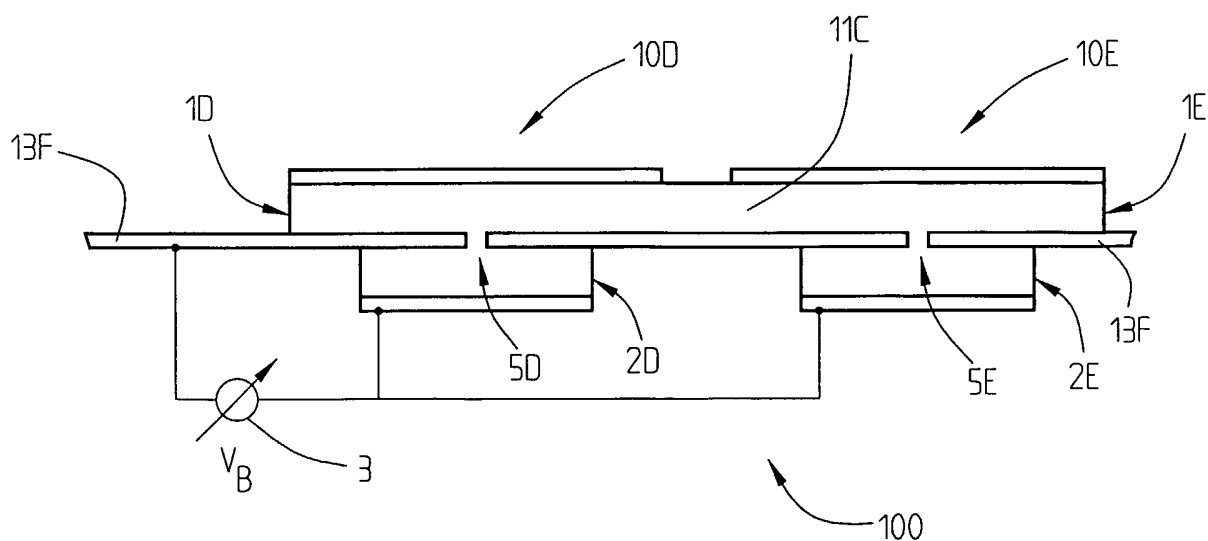

Fig. 11

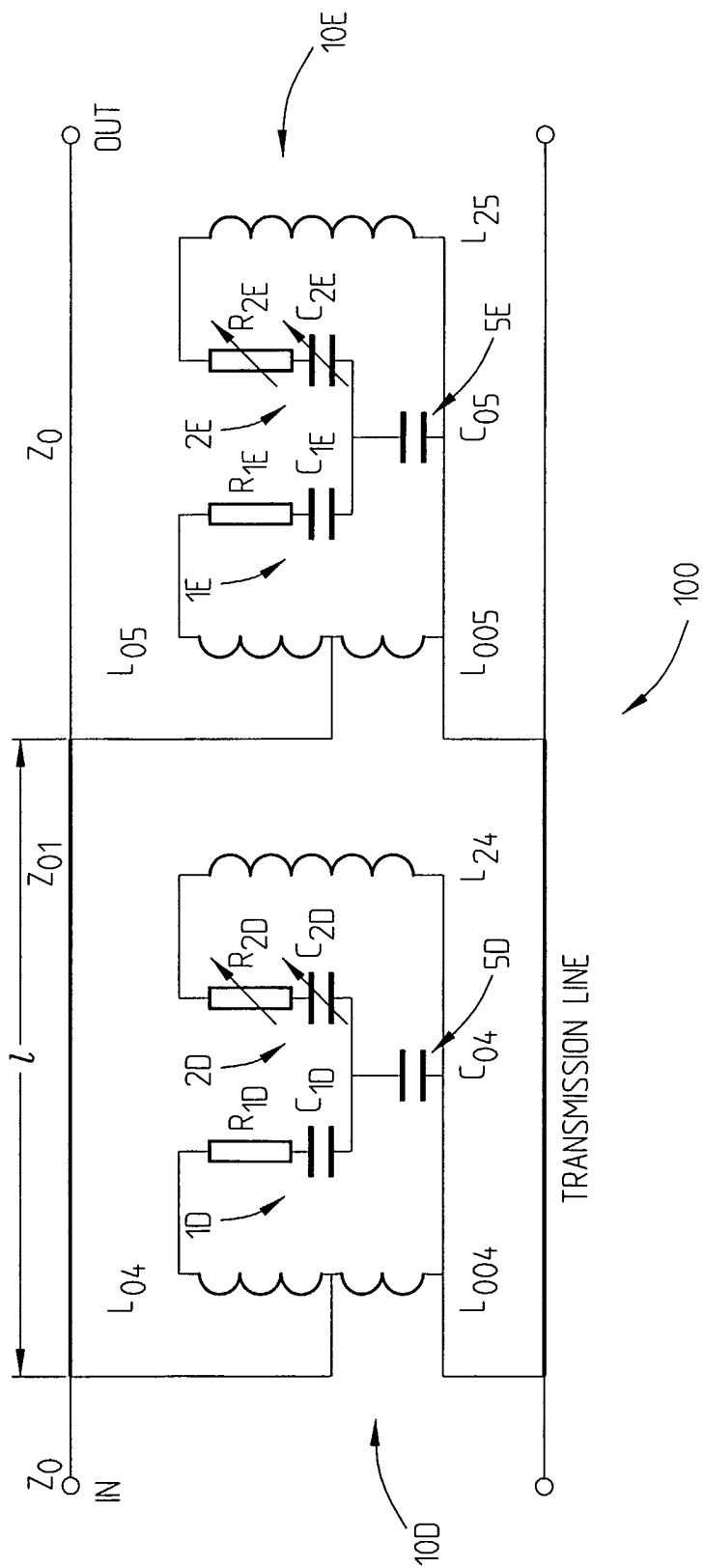

Fig. 12

10/10

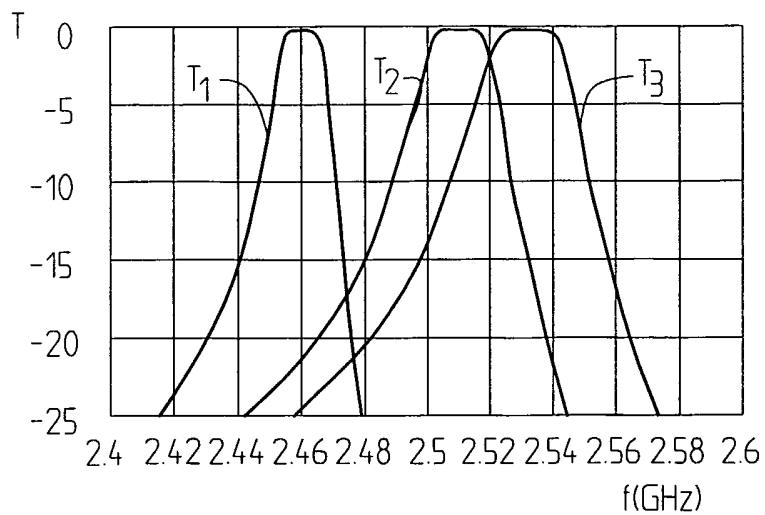

Fig. 13A

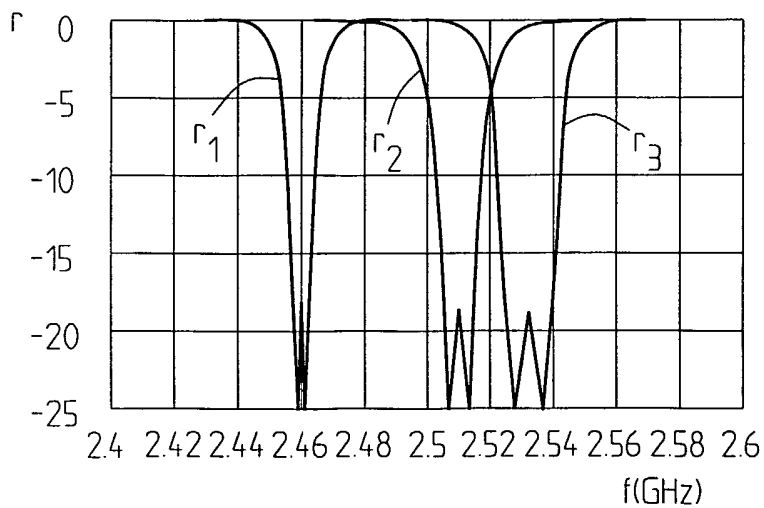

Fig. 13B

INTERNATIONAL SEARCH REPORT

International application No.

PCT/SE 02/01461

A. CLASSIFICATION OF SUBJECT MATTER

IPC7: H01P 1/203, H01P 7/10

According to International Patent Classification (IPC) or to both national classification and IPC

B. FIELDS SEARCHED

Minimum documentation searched (classification system followed by classification symbols)

IPC7: H01P

Documentation searched other than minimum documentation to the extent that such documents are included in the fields searched

SE,DK,FI,NO classes as above

Electronic data base consulted during the international search (name of data base and, where practicable, search terms used)

EPO-INTERNAL, WPI DATA, PAJ, INSPEC

C. DOCUMENTS CONSIDERED TO BE RELEVANT

Category*	Citation of document, with indication, where appropriate, of the relevant passages	Relevant to claim No.
A	US 6114758 A (ALFREDO CARLOS ANDERSON ET AL), 5 Sept 2000 (05.09.00), column 3, line 21 - column 5, line 39 --	1-27
A	US 5914296 A (ZHI-YUAN SHEN), 22 June 1999 (22.06.99), see whole document --	1-24
A	ELECTRONICS LETTERS, Volume 37, No 17, August 2001, P.K. PETROV ET AL, "Tunable dielectric resonator with ferroelectric element" page 1066 - page 1067 --	1-27



Further documents are listed in the continuation of Box C.



See patent family annex.

* Special categories of cited documents:

"A" document defining the general state of the art which is not considered to be of particular relevance

"E" earlier application or patent but published on or after the international filing date

"L" document which may throw doubts on priority claim(s) or which is cited to establish the publication date of another citation or other special reason (as specified)

"O" document referring to an oral disclosure, use, exhibition or other means

"P" document published prior to the international filing date but later than the priority date claimed

"I" later document published after the international filing date or priority date and not in conflict with the application but cited to understand the principle or theory underlying the invention

"X" document of particular relevance: the claimed invention cannot be considered novel or cannot be considered to involve an inventive step when the document is taken alone

"Y" document of particular relevance: the claimed invention cannot be considered to involve an inventive step when the document is combined with one or more other such documents, such combination being obvious to a person skilled in the art

"&" document member of the same patent family

Date of the actual completion of the international search

4 November 2002

Date of mailing of the international search report

07-11-2002

Name and mailing address of the ISA/

Swedish Patent Office
Box 5055, S-102 42 STOCKHOLM
Facsimile No. +46 8 666 02 86

Authorized officer

Bo Gustavsson/MN
Telephone No. +46 8 782 25 00

INTERNATIONAL SEARCH REPORT

International application No.

PCT/SE 02/01461

C (Continuation). DOCUMENTS CONSIDERED TO BE RELEVANT		
Category*	Citation of document, with indication, where appropriate, of the relevant passages	Relevant to claim No.
A	US 9642118 A (TELEFONAKTIEBOLAGET LM ERICSSON), 27 December 1996 (27.12.96), page 15, line 21 - page 16, line 6, figures 11,12 --	1-27
A	IEEE TRANSACTIONS ON APPLIED SUPERCONDUCTIVITY, Volume 7, No 2, June 1997, Spartak S. Gevorgian et al, "HTS/Ferroelectric Devices for Microwave Applications" page 2458 - page 2461 -- -----	1-27

INTERNATIONAL SEARCH REPORT
Information on patent family members

30/09/02

International application No.

PCT/SE 02/01461

Patent document cited in search report	Publication date	Patent family member(s)	Publication date
US 6114758 A	05/09/00	NONE	
US 5914296 A	22/06/99	AT 205640 T CA 2255648 A CN 1220031 A DE 69706673 D,T DK 900453 T EP 0900453 A,B SE 0900453 T3 ES 2163168 T JP 2000511375 T KR 2000015929 A PT 900453 T TW 426227 Y WO 9744852 A	15/09/01 27/11/97 16/06/99 20/06/02 29/10/01 10/03/99 16/01/02 29/08/00 15/03/00 28/02/02 00/00/00 27/11/97
US 9642118 A	27/12/96	NONE	